

# TZIDC, TZIDC-110, TZIDC-120

## Digital Positioner



Digital Positioner for the positioning of pneumatically controlled final control elements.

—  
TZIDC  
TZIDC-110  
TZIDC-120

### Introduction

The TZIDC, TZIDC-110, TZIDC-120 is an electronically configurable positioner with communication capabilities designed for mounting on pneumatic linear or rotary actuators.

Fully automatic determination of the control parameters and adaptation to the positioner allow for considerable time savings as well as optimum control behavior.

### Additional Information

Additional documentation on TZIDC, TZIDC-110, TZIDC-120 is available for download free of charge at [www.abb.com/positioners](http://www.abb.com/positioners).

Alternatively simply scan this code:



## Table of contents

<b>1 Safety</b> .....	<b>3</b>	Connection on the device.....	38
General information and instructions.....	3	Conductor cross-section.....	39
Warnings.....	3	Connection on device - TZIDC Control Unit with TZIDC Remote Sensor.....	40
Intended use.....	4	Connection on device - TZIDC Control Unit for remote position sensor.....	41
Improper use.....	4		
Notes on data safety.....	4		
Manufacturer's address.....	4		
<b>2 Use in potentially explosive atmospheres</b> .....	<b>5</b>	<b>7 Pneumatic Connections</b> .....	<b>42</b>
General requirements.....	5	Information on double acting actuators with spring-return mechanism.....	42
Commissioning, Installation.....	5	Connection on the device.....	42
Notes for operation.....	5	Air supply.....	43
Use, operation.....	5		
Maintenance, repair.....	6	<b>8 Commissioning</b> .....	<b>43</b>
Preconditions for safe operation of the positioner.....	7	TZIDC.....	43
Cable gland.....	7	Operating modes.....	44
TZIDC – Ex relevant specification.....	8	TZIDC-110 / TZIDC-120.....	44
ATEX – ‘Ex i’ type of protection.....	8	Setting the bus address.....	45
ATEX – ‘Ex n’ type of protection.....	9	Request information.....	45
IECEX – ‘Ex i’ and ‘Ex n’ type of protection.....	10	Operating modes.....	46
FM / CSA.....	12	Jumper configuration.....	46
TZIDC-110 – Ex relevant specification.....	14	Standard automatic adjustment.....	46
ATEX – ‘Ex i’ type of protection.....	14	Standard automatic adjustment for linear actuators*.....	46
ATEX – ‘Ex n’ type of protection.....	14	Standard automatic adjustment for rotary actuators*.....	46
IECEX – ‘Ex i’ and ‘Ex n’ type of protection.....	15	Sample parameters.....	47
FM / CSA.....	16	Setting the mechanical position indication.....	47
TZIDC-120 – Ex relevant specification.....	19	Setting the mechanical limit switch with proximity switches.....	48
ATEX – ‘Ex i’ type of protection.....	19	Setting the mechanical limit switch with 24 V microswitches.....	48
ATEX – ‘Ex n’ type of protection.....	19		
IECEX – ‘Ex i’ and ‘Ex n’ type of protection.....	20	<b>9 Operation</b> .....	<b>49</b>
FM / CSA.....	21	Safety instructions.....	49
<b>3 Product identification</b> .....	<b>23</b>	Parameterization of the device.....	49
Name plate.....	23	Menu navigation.....	49
<b>4 Transport and storage</b> .....	<b>24</b>	Menu levels.....	50
Inspection.....	24	<b>10 Maintenance</b> .....	<b>50</b>
Transporting the device.....	24	<b>11 Recycling and disposal</b> .....	<b>50</b>
Storing the device.....	24	<b>12 Additional documents</b> .....	<b>50</b>
Ambient conditions.....	24	<b>13 Appendix</b> .....	<b>51</b>
Returning devices.....	24	Return form.....	51
<b>5 Installation</b> .....	<b>25</b>	FM installation drawing No. 901064.....	52
Safety instructions.....	25	FM installation drawing No. 901265.....	56
External position sensors.....	26		
Mechanical mounting.....	27		
General.....	27		
Mounting on linear actuators.....	28		
Mounting on rotary actuator.....	30		
<b>6 Electrical connections</b> .....	<b>32</b>		
Safety instructions.....	32		
TZIDC / TZIDC Control Unit terminal assignment.....	33		
TZIDC Remote Sensor terminal assignment.....	34		
TZIDC-110, TZIDC-120 terminal assignment.....	35		
Electrical data for inputs and outputs.....	36		
Option modules.....	37		

# 1 Safety

## General information and instructions

These instructions are an important part of the product and must be retained for future reference.

Installation, commissioning, and maintenance of the product may only be performed by trained specialist personnel who have been authorized by the plant operator accordingly. The specialist personnel must have read and understood the manual and must comply with its instructions.

For additional information or if specific problems occur that are not discussed in these instructions, contact the manufacturer.

The content of these instructions is neither part of nor an amendment to any previous or existing agreement, promise or legal relationship.

Modifications and repairs to the product may only be performed if expressly permitted by these instructions.

Information and symbols on the product must be observed.

These may not be removed and must be fully legible at all times.

The operating company must strictly observe the applicable national regulations relating to the installation, function testing, repair and maintenance of electrical products.

## Warnings

The warnings in these instructions are structured as follows:

### **DANGER**

The signal word '**DANGER**' indicates an imminent danger. Failure to observe this information will result in death or severe injury.

### **WARNING**

The signal word '**WARNING**' indicates an imminent danger. Failure to observe this information may result in death or severe injury.

### **CAUTION**

The signal word '**CAUTION**' indicates an imminent danger. Failure to observe this information may result in minor or moderate injury.

### **NOTICE**

The signal word '**NOTICE**' indicates possible material damage.

### **Note**

'**Note**' indicates useful or important information about the product.

## ... 1 Safety

### Intended use

Positioning of pneumatically controlled actuators; designed for mounting on linear and rotary actuators.

The device is designed for use exclusively within the stated values on the name plate and in the data sheet.

- The maximum operating temperature must not be exceeded.
- The maximum ambient temperature must not be exceeded.
- The housing's rating must be observed during operation.

### Improper use

The following are considered to be instances of improper use of the device:

- For use as a climbing aid, for example for mounting purposes.
- For use as a bracket for external loads, for example as a support for piping, etc.
- Material application, for example by painting over the housing, name plate or welding/soldering on parts.
- Material removal, for example by spot drilling the housing.

### Notes on data safety

This product is designed to be connected to and to communicate information and data via a network interface.

It is operator's sole responsibility to provide and continuously ensure a secure connection between the product and your network or any other network (as the case may be).

Operator shall establish and maintain any appropriate measures (such as but not limited to the installation of firewalls, application of authentication measures, encryption of data, installation of anti-virus programs, etc.) to protect the product, the network, its system and the interface against any kind of security breaches, unauthorized access, interference, intrusion, leakage and / or theft of data or information.

ABB Automation Products GmbH and its affiliates are not liable for damages and / or losses related to such security breaches, any unauthorized access, interference, intrusion, leakage and / or theft of data or information.

### Manufacturer's address

**ABB Automation Products GmbH  
Measurement & Analytics**

Schillerstr. 72

32425 Minden

Germany

Tel: +49 571 830-0

Fax: +49 571 830-1806

### Customer service center

Tel: +49 180 5 222 580

Email: [automation.service@de.abb.com](mailto:automation.service@de.abb.com)

## 2 Use in potentially explosive atmospheres

### General requirements

- The ABB positioner has been approved only for appropriate and intended use in standard industrial atmospheres. Any breach of this rule leads to a cancellation of warranty and manufacturer's responsibility!
- Make sure that only devices which comply with the types of protection relevant to the applicable zones and categories are installed.
- All electric equipment has to be suited for the respective intended use.
- In potentially explosive atmospheres, assembly may be conducted only in compliance with locally applicable installation regulations. The following conditions have to be observed (incomplete):
  - Assembly and maintenance may only be conducted if there is no explosion hazard in the area and you have a hot work permit.
  - The TZIDC, TZIDC-110, TZIDC-120 may be operated in a fully mounted and intact housing only.

### Commissioning, Installation

The ABB positioner has to be mounted in a major system. Depending on the degrees of IP-protection, an interval for cleaning the equipment (dust settlement) has to be defined. Strict care has to be taken that only devices which comply with the types of protection relevant to the applicable zones and categories is installed. When installing the device, the locally applicable installation regulations, such as EN 60079-14, must be observed.

Other important facts to be observed:

- The electric circuits of the positioner must be put into operation in all zones by persons qualified in accordance with TRBS 1203. The details on the type label are mandatory for doing this.
- The device has been designed in accordance with IP 65 (optionally IP 66) and must be protected accordingly against adverse ambient conditions.
- The EC Type Examination Certificate has to be taken into account, including any special conditions defined therein.
- The device may only be used in accordance with its intended use.
- The device may only be connected when de-energized.
- The potential equalization of the system must be established in accordance with installation regulations applicable in the respective country (VDE 0100, part 540, IEC 364-5-54).
- Circulating currents must not be guided through the housing!
- Make sure that the housing is properly installed and that its IP rating has not been compromised.

### Notes for operation

- The positioner must be integrated in the local potential equalization system.
- Only either intrinsically safe or non intrinsically safe circuits may be connected. A combination is not permitted.
- If the positioner is operated with non intrinsically safe circuits, later use for the intrinsic safety type of protection is not permitted.

### Use, operation

The TZIDC, TZIDC-110, TZIDC-120 is approved for proper and intended use only. In case of non-compliance, the warranty and manufacturer's liability do no longer apply!

- Only those auxiliary components which fulfill all the requirements of European and national standards may be used in potentially explosive atmospheres.
- The ambient conditions specified in the operating instruction must be strictly followed.
- The TZIDC, TZIDC-110, TZIDC-120 is approved for proper and intended use in standard industrial atmospheres only. Where aggressive substances are present in the air, the manufacturer has to be consulted.

## ... 2 Use in potentially explosive atmospheres

### Maintenance, repair

Definition of terms according to IEC 60079-17:

#### Maintenance

Defines a combination of actions performed to maintain or restore the condition of an item such that the item meets the requirements of the relevant specification and performs its required functions.

#### I –Analyzer module without electronics module (power supply):

Defines an action which involves careful inspection of an item (either without disassembly or with partial disassembly, as required) supplemented by measurements, aimed at achieving a reliable conclusion regarding the condition of the item.

#### Visual inspection

Defines an inspection which identifies defects which are visible to the naked eye, such as missing screws, without the use of access equipment and tools.

#### Close inspection

Defines an inspection which encompasses the aspects covered by a visual inspection and in addition, identifies defects such as loose screws, which can only be detected with the use of access equipment (e.g. steps) and tools.

#### Detailed inspection

Defines an inspection which encompasses the aspects covered by a close inspection and in addition, identifies defects, such as loose connections, which can only be detected by opening the housing and / or by using tools and test devices, as needed.

- Maintenance and exchange work may be conducted by qualified specialists only, i.e., qualified personnel in accordance with TRBS 1203 or similar.
- Only those auxiliary components which fulfill all the requirements of European and national guidelines and regulations may be used in potentially explosive atmospheres.
- Maintenance works that require disassembly of the system may only be performed in non-hazardous areas. If that is not possible, however, the usual precautions have to be ensured according to local regulations.
- Components may only be replaced by original spare parts which are therefore approved for use in potentially explosive atmospheres.
- The device must be regularly cleaned when used in potentially explosive atmospheres. The intervals must be defined by the operator in compliance with the ambient conditions present at the operating location.
- After all maintenance and repair work has been completed, any barriers and plates removed for that purpose must be put back in their original place.
- The flameproof joints differ from the tables of IEC 60079-1 and may be repaired by the manufacturer only.

Activity	Visual inspection (every 3 months)	Close inspection (every 6 months)	Detailed inspection (every 12 months)
Visual inspection of the positioner for integrity, removal of dust deposits	●		
Inspection of electric installation for integrity and proper operation			●
Inspection of the entire installation		Responsibility of the operator	

## Preconditions for safe operation of the positioner

### DANGER

#### Risk of explosion due to hot parts

Hot parts inside the device pose an explosion hazard.

- Never open the device immediately after switch-off.
- A waiting time of at least four minutes should be observed before opening the device.

When using in hazardous areas, observe the following points:

- Observe the specification and special conditions applicable for the device in accordance with the relevant valid certificate.
- Manipulation of the device in any form by the user is not permitted. Only the manufacturer or an explosion protection specialist may modify the device
- The IP 65 / NEMA 4x IP rating is only achieved if the splash guard is screwed in place. Operating the unit without splash guard cap is prohibited.
- The device may only be operated using instrument air that is free from oil, water and dust. The use of flammable gas, oxygen, or oxygen-enriched gas is not permitted.

#### Cable gland

Limited temperature range of the M20 × 1.5 plastic cable gland for explosion protection variants.

The permissible ambient temperature range of the cable gland is -20 to 80 °C (-4 to 176 °F). When using the cable gland, make sure that the ambient temperature is within this range. The cable gland must be installed in the housing with a tightening torque of 3.8 Nm. When installing the connection of the cable gland and cable, check for tightness to ensure that the required IP rating is met.

## ... 2 Use in potentially explosive atmospheres

### TZIDC – Ex relevant specification

#### Note

The values indicated here are taken from the respective certificates. Always observe the specifications and supplements in the explosion protection certificates.

#### ATEX – ‘Ex i’ type of protection

##### Ex marking

Ex marking	
Marking	II 2 G Ex ia IIC T6 or T4 Gb II 2 G Ex ib IIC T6 or T4 Gb II 2 D Ex ia IIIC T51°C resp. 70°C Db
Type Examination Test Certificate	TÜV 04 ATEX 2702 X
Type	Intrinsically safe equipment
	II 2 G
	EN 60079-0
	EN 60079-11
Device class	II 2D
Standards	EN 60079-0 EN 61241-11

#### Temperature Data

##### Device group II 2 G

Temperature class	Ambient temperature Ta
T4	-40 to 85 °C
T5	-40 to 50 °C
T6*	-40 to 40 °C*

\* When using the ‘digital feedback’ plug-in module in temperature class T6, the maximum permissible ambient temperature range is -40 to 35 °C.

##### Device group II 2 D

Housing surface temperature	Ambient temperature Ta
T81 °C	-40 to 70 °C
T61 °C	-40 to 50 °C
T51 °C	-40 to 40 °C*

#### Electrical Data

In intrinsically safe types of protection Ex ib IIC / Ex ia IIC or Ex iaD, only for connection to a certified intrinsically safe circuit.

Current circuit (terminal)	Electrical information (maximum values)	
Signal circuit (+11 / -12)	U <sub>i</sub> = 30 V I <sub>i</sub> = 320 mA P <sub>i</sub> = 1.1 W	C <sub>i</sub> = 6.6 nF L <sub>i</sub> = negligibly small
Contact input (+81 / -82)	U <sub>i</sub> = 30 V I <sub>i</sub> = 320 mA P <sub>i</sub> = 1.1 W	C <sub>i</sub> = 4.2 nF L <sub>i</sub> = negligibly small
Switch output (+83 / -84)	U <sub>i</sub> = 30 V I <sub>i</sub> = 320 mA P <sub>i</sub> = 500 mW	C <sub>i</sub> = 4.2 nF L <sub>i</sub> = negligibly small
Mechanical digital feedback (Limit1: +51 / -52), (Limit2: +41 / -42)	For maximum values, see EC type examination certificate number PTB 00 ATEX 2049 X Proximity switches by Pepperl & Fuchs	
Plug-in module for digital position feedback (+51 / -52) (+41 / -42)	U <sub>i</sub> = 30 V I <sub>i</sub> = 320 mA P <sub>i</sub> = 250 mW	C <sub>i</sub> = 3.7 nF L <sub>i</sub> = negligibly small
Plug-in module for analog position feedback (+31 / -32)	U <sub>i</sub> = 30 V I <sub>i</sub> = 320 mA P <sub>i</sub> = 1.1 W	C <sub>i</sub> = 6.6 nF L <sub>i</sub> = negligibly small
Optional interface to remote sensor (X2-2: +Uref, X3-2: GND, X3-1: Signal)	U <sub>0</sub> = 5.4 V I <sub>0</sub> = 74 mA P <sub>0</sub> = 100 mW C <sub>i</sub> = negligibly small L <sub>i</sub> = negligibly small	Type of protection Ex ia or Ex ib IIC: L <sub>0</sub> = 5 mH C <sub>0</sub> = 2 µF IIB: L <sub>0</sub> = 5 mH C <sub>0</sub> = 10 µF
Local communication interface (LCI)	Only for connection to a programming device outside of the hazardous area. (See special conditions).	



**Special conditions**

- The local communication interface (LCI) may only be operated at  $U_m \leq 30$  V DC outside the hazardous area.
- Variants that, according to declarations, also meet the requirements for the 'flameproof enclosure' type of protection may no longer be used as 'intrinsically safe' if they have been previously used as a flameproof type of protection
- When used with gases from group IIA and a temperature class of T1 for power supply, the TZIDC positioner may only be used outdoors or inside sufficiently ventilated buildings.
- The gas supplied must be kept sufficiently free of air and oxygen to prevent an ignitable atmosphere from forming.
- The equipment may only be used as a II 2 D type device in areas where the level of mechanical hazard is 'low'.
- Cable entries that meet the requirements of EN 61241-11 for Category II 2 D as well as the ambient temperature range must be used.
- Prevent electrostatic charging due to propagating brush discharge when the equipment is used for applications involving combustible dust.

**ATEX – 'Ex n' type of protection****Ex marking**

<b>Ex marking</b>	
Marking	II 3 G Ex nA IIC T6 or T4 Gc
Type Examination Test Certificate	TÜV 02 ATEX 1943 X
Type	'n' type of protection
Device class	II 3 G
Standards	EN 60079-15 EN 60079-0

**Temperature Data****Device group II 3 G**

<b>Temperature class</b>	<b>Ambient temperature <math>T_a</math></b>
T4	-40 to 85 °C
T6	-40 to 50 °C

**Electrical Data**

<b>Current circuit (terminal)</b>	<b>System bus, computer interfaces</b>
Signal circuit (+11 / -12)	U = 9.7 V DC I = 4 to 20 mA, max. 21.5 mA
Contact input (+81 / -82)	U = 12 to 24 V DC; 4 mA
Switch output (+83 / -84)	U = 11 V DC
Mechanical digital feedback (Limit1: +51 / -52) (Limit2: +41 / -42)	U = 5 to 11 V DC
Plug-in module for digital position feedback (+51 / -52) (+41 / -42)	U = 5 to 11 V DC
Plug-in module for analog position feedback (+31 / -32)	U = 10 to 30 V DC I = 4 to 20 mA, max. 21.5 mA

## ... 2 Use in potentially explosive atmospheres

### ... TZIDC – Ex relevant specification

#### Special conditions

- Devices must only be connected to circuits in zone 2 if they are suitable for operation in zone 2 potentially explosive atmospheres and for the conditions prevailing at the installation location (manufacturer's declaration or certificate from an inspection authority).
- For the 'digital feedback with proximity switches' circuit, external measures must be implemented to prevent the rated voltage from being exceeded by more than 40 % in the event of transient disturbances
- It is only permissible to connect, disconnect, and switch live circuits during installation or maintenance, or for the purpose of carrying out repairs. Note: It is considered very unlikely that a potentially hazardous atmosphere would be present in zone 2 at the same time that installation or maintenance or repair work was being carried out.
- Only non-flammable gases may be used for the pneumatic power supply
- Only suited cable entries must be used that meet the requirements of EN 60079-15.

#### IECEx – 'Ex i' and 'Ex n' type of protection

##### Ex marking

Ex marking	
Marking	Ex ia IIC T6 or T4 Gb Ex ib IIC T6 or T4 Gb Ex nA IIC T6 or T4 Gc
Type Examination Test Certificate	IECEx TUN 04.0015X
Shown as	5
Type	Intrinsic safety 'I' or Type of protection 'n'
Standards	IEC 60079-0 IEC 60079-11 IEC 60079-15

##### Temperature Data

Temperature class	TaTZIDC Ex ia IIC resp. Ex ib IIC
Ambient temperature	
T4	-40 to 85 °C
T6*	-40 to 40 °C

\* When using the 'digital feedback' plug-in module in temperature class T6, the maximum permissible ambient temperature range is -40 to 35 °C.

##### Electrical Data

Electric data for TZIDC with Ex ia IIC or Ex ib IIC marking. In 'intrinsic safety Ex ib IIC / Ex ia IIC' type of protection, only for connection to a certified intrinsically safe circuit.

Current circuit (terminal)	Electrical information (maximum values)	
Signal circuit (+11 / -12)	U <sub>i</sub> = 30 V I <sub>i</sub> = 320 mA P <sub>i</sub> = 1.1 W	C <sub>i</sub> = 6.6 nF L <sub>i</sub> = negligibly small
Contact input (+81 / -82)	U <sub>i</sub> = 30 V I <sub>i</sub> = 320 mA P <sub>i</sub> = 1.1 W	C <sub>i</sub> = 4.2 nF L <sub>i</sub> = negligibly small
Switch output (+83 / -84)	U <sub>i</sub> = 30 V I <sub>i</sub> = 320 mA P <sub>i</sub> = 500 mW	C <sub>i</sub> = 4.2 nF L <sub>i</sub> = negligibly small
Local communication interface (LCI)	Only for connection to a programming device outside of the hazardous area. (See special conditions).	

The following modules may be operated as an option:

Current circuit (terminal)	Electrical information (maximum values)	
Plug-in module for digital position feedback (+51 / -52) (+41 / -42)	$U_i = 30 \text{ V}$	$C_i = 3.7 \text{ nF}$
	$I_i = 320 \text{ mA}$	$L_i = \text{negligibly small}$
	$P_i = 250 \text{ mW}$	
Plug-in module for analog position feedback (+31 / -32)	$U_i = 30 \text{ V}$	$C_i = 6.6 \text{ nF}$
	$I_i = 320 \text{ mA}$	$L_i = \text{negligibly small}$
	$P_i = 1.1 \text{ W}$	

Electric data for TZIDC with Ex nA IIC T6 or T4 Gc marking

Current circuit (terminal)	Electrical information (maximum values)	
Signal circuit (+11 / -12)	$U = 9.7 \text{ V DC}$	
	$I = 4 \text{ to } 20 \text{ mA, max. } 21.5 \text{ mA}$	
Contact input (+81 / -82)	$U = 12 \text{ to } 24 \text{ V DC; } 4 \text{ mA}$	
Switch output (+83 / -84)	$U = 11 \text{ V DC}$	

The following modules may be operated as an option:

Current circuit (terminal)	Electrical information (maximum values)	
Plug-in module for digital position feedback (+51 / -52) (+41 / -42)	$U = 5 \text{ to } 11 \text{ V DC}$	
Plug-in module for analog position feedback (+31 / -32)	$U = 10 \text{ to } 30 \text{ V DC}$	
	$I = 4 \text{ to } 20 \text{ mA, max. } 21.5 \text{ mA}$	

### Special conditions

- Devices must only be connected to circuits in zone 2 if they are suitable for operation in zone 2 potentially explosive atmospheres and for the conditions prevailing at the installation location (manufacturer's declaration or certificate from an inspection authority).
- For the 'digital feedback with proximity switches' circuit, external measures must be implemented to prevent the rated voltage from being exceeded by more than 40 % in the event of transient disturbances
- It is only permissible to connect, disconnect, and switch live circuits during installation or maintenance, or for the purpose of carrying out repairs. Note: It is considered very unlikely that a potentially hazardous atmosphere would be present in zone 2 at the same time that installation or maintenance or repair work was being carried out.
- Only non-flammable gases must be used for pneumatic power supply.
- Only suited cable entries must be used that meet the requirements of EN 60079-15.

## ... 2 Use in potentially explosive atmospheres

### ... TZIDC – Ex relevant specification

#### FM / CSA

#### CSA International

Certificate	
Certificate	1052414
Class 2258 02	PROCESS CONTROL EQUIPMENT – For Hazardous Locations
Class 2258 04	PROCESS CONTROL EQUIPMENT – Intrinsically Safe, Entity – For Hazardous Locations

#### Electric data

Model TZIDC, P/N V18345-x0x2x2xx0x Intelligent Positioner	
For use in	Class I, Div 2, Groups A, B, C and D Class II, Div 2, Groups E, F, and G Class III, Enclosure Type 4X
Input rated	30 V DC; max. 4 to 20 mA
Max output pressure	90 psi
Max. ambient temperature	85 °C

#### Model TZIDC, P/N V18345-x0x2x2xx0x Intelligent Positioner intrinsically safe with entity parameters of:

For use in	Class I, Div 1, Groups A, B, C and D; Class II, Div 1, Groups E, F and G Class III, Enclosure Type 4X:	
Terminals 11 / 12	V max = 30 V I max = 104 mA	C <sub>i</sub> = 6.6 nF L <sub>i</sub> = 0 μH
Terminals 81 / 82	V max = 30 V I max = 110 mA	C <sub>i</sub> = 4.2 nF L <sub>i</sub> = 0 μH
Terminals 83 / 84	V max = 30 V I max = 90 mA	C <sub>i</sub> = 4.2 nF L <sub>i</sub> = 0 μH
Terminals 31 / 32	V max = 30 V I max = 110 mA	C <sub>i</sub> = 6.6 nF L <sub>i</sub> = 0 μH
Terminals 41 / 42 and 51 / 52	V max = 30 V I max = 96 mA	C <sub>i</sub> = 3.7 nF L <sub>i</sub> = 0 μH
Terminals Limit 2 41 / 42 and Limit 1 51 / 52	V max = 15.5 V I max = 52 mA	C <sub>i</sub> = 20 nF L <sub>i</sub> = 30 μH

#### Note

- The “x” in P/N denotes minor mechanical variations or optional features.
- Local communication interface (LCI) shall not be used in hazardous location.
- Each pair of conductors of each intrinsic safety circuit shall be shielded.
- See FM installation drawing No. 901064 for Details.

**CSA certification record****Certificate**

Certificate	1649904 (LR 20312)
Class 2258 04	PROCESS CONTROL EQUIPMENT – Intrinsically Safe, Entity – For Hazardous Locations

**Electric data****Model TZIDC, P/N V18345-x0x2x2xx0x Intelligent Positioner**

For use in	Class I, Div 1, Groups A, B, C and D; Class II, Div 1, Groups E, F, and G, Class III, Div 1, Enclosure Type 4X
------------	--

Input rated	30 V DC; max.4 to 20 mA
-------------	-------------------------

Output pressure	Max. 90 psi
-----------------	-------------

**Intrinsically safe with entity parameters of:**

Terminals 11 / 12	V max = 30 V I max = 104 mA	C <sub>i</sub> = 6.6 nF L <sub>i</sub> = 0 μH
Terminals 81 / 82	V max = 30 V I max = 110 mA	C <sub>i</sub> = 3.7 nF L <sub>i</sub> = 0 μH
Terminals 83 / 84	V max = 30 V I max = 96 mA	C <sub>i</sub> = 3.7 nF L <sub>i</sub> = 0 μH
Terminals 31 / 32	V max = 30 V I max = 110 mA	C <sub>i</sub> = 6.6 nF L <sub>i</sub> = 0 μH
Terminals 41 / 42 and 51 / 52	V max = 30 V I max = 96 mA	C <sub>i</sub> = 3.7 nF L <sub>i</sub> = 0 μH
Terminals Limit 2 41 / 42 and Limit 1 51 / 52	V max = 15.5 V I max = 52 mA	C <sub>i</sub> = 20 nF L <sub>i</sub> = 30 μH

**When installed per installation Drawing No 901064:**

Temperature Code	T4
Max. Ambient temperature	85 °C

**Note**

- The 'x' in P/N denotes minor mechanical variations or optional features.
- Local communication interface LCI shall not be used in hazardous location.
- Each pair of conductors of each intrinsic safety circuit shall be shielded.
- See FM installation drawing No. 901064 for Details.

**FM approvals****TZIDC Positioner, Model V18345-a0b2c2de0f**

IS/I,II,III/1/ABCDEFGH/T4 Ta = 85 °C – 901064/7/4; Entity;

NI/I/2/ABCD/T4 Ta = 85 °C;

S/II,III/2/FG/T4 Ta = 85 °C; Type 4X

Max Entity Parameters: Per Control Drawings

- Case/mounting – 1, 2, 3, 4 or 9
- Input/communication port – 1 or 2
- Output/safe protection – 1, 2, 4 or 5
- Option modules for analog or digital position feedback – 0, 1, 3 or 5
- Mechanical kit (proximity switches) for digital position feedback (option) – 0, 1 or 3
- Design (varnish/coding) – 1 or 2

See FM installation drawing No. 901064 for Details.

## ... 2 Use in potentially explosive atmospheres

### TZIDC-110 – Ex relevant specification

**Note**

The values indicated here are taken from the respective certificates. Always observe the specifications and supplements in the explosion protection certificates.

**ATEX – ‘Ex i’ type of protection**

Ex marking	
Marking	II 2 G Ex ia IIC T6 or. T4 Gb II 3 G Ex ic IIC T6 or T4 Gc
Type Examination Test Certificate	TÜV 02 ATEX 1831 X
Type	Intrinsically safe equipment
Standards	EN 60079-0 EN 60079-11

**Temperature Data**

Temperature class	Ambient temperature Ta
T4	-40 to 85 °C
T6	-40 to 40 °C

**Electrical Data**

**ia / ib / ic for Grp. IIB / IIC**

With the intrinsically safe Ex i IIC type of protection, only for connection to a certified FISCO power supply unit, a barrier or a power supply unit with linear characteristic curves and the following maximum values:

Current circuit (terminal)	Electrical information (maximum values)
Signal circuit (+11 / -12 or + / -)	$U_i = 24 \text{ V}$ Characteristic curve: $I_i = 250 \text{ mA}$ linear $P_i = 1.2 \text{ W}$ $L_i < 10 \mu\text{H}$ $C_i < 5 \text{ nF}$

With the intrinsically safe Ex i IIC type of protection, only for connection to a certified intrinsically safe circuit with maximum values:

Current circuit (terminal)	Electrical information (maximum values)
Mechanical digital feedback (Limit1: +51 / -52) (Limit2: +41 / -42)	See EC type examination certificate PTB 00 ATEX 2049 X

**ATEX – ‘Ex n’ type of protection**

Ex marking	
Marking	II 3 G Ex nA IIC T6 or T4 Gc
Type Examination Test Certificate	TÜV 02 ATEX 1943 X
Type	‘n’ type of protection
Device class	II 3 G
Standards	EN 60079-15 EN 60079-0

**Temperature Data**

Device group II 3 G	
Temperature class	Ambient temperature Ta
T4	-40 to 85 °C
T6	-40 to 50 °C

**Electrical Data**

Current circuit (terminal)	System bus, computer interfaces
Signal circuit (+11 / -12)	U = 9 to 32 V DC I = 10.5 mA
Mechanical digital feedback (Limit1: +51 / -52) (Limit2: +41 / -42)	U = 5 to 11 V DC

**Special conditions**

- Devices must only be connected to circuits in zone 2 if they are suitable for operation in zone 2 potentially explosive atmospheres and for the conditions prevailing at the installation location (manufacturer's declaration or certificate from an inspection authority).
- For the 'digital feedback with proximity switches' circuit, external measures must be implemented to prevent the rated voltage from being exceeded by more than 40 % in the event of transient disturbances
- It is only permissible to connect, disconnect, and switch live circuits during installation or maintenance, or for the purpose of carrying out repairs. Note: It is considered very unlikely that a potentially hazardous atmosphere would be present in zone 2 at the same time that installation or maintenance or repair work was being carried out.
- Only non-flammable gases may be used for the pneumatic power supply
- Only suited cable entries must be used that meet the requirements of EN 60079-15.

**IECEX – 'Ex i' and 'Ex n' type of protection**

<b>Ex marking</b>	
Marking	Ex ia IIC T6 or T4 Gb Ex ib IIC T6 or T4 Gb Ex ic IIC T6 or T4 Gc Ex nA IIC T6 or T4 Gc
Type Examination Test Certificate	IECEX TUN 04.0015X
Shown as	5
Type	Intrinsic safety 'I' or type of protection 'n'
Standards	IEC 60079-0 IEC 60079-11 IEC 60079-15

**Temperature Data**

<b>Temperature class</b>	<b>Ambient temperature Ta</b>	
	<b>TZIDC-110 Ex i IIC</b>	<b>TZIDC-110 Ex nA IIC</b>
T4	-40 to 85 °C	-40 to 85 °C
T6	-40 to 40 °C	-40 to 50 °C

**Electrical Data****TZIDC-110 for ia / ib / ic with Ex i IIC T6 or T4 Gb marking**

With the intrinsically safe Ex i IIC type of protection, only for connection to a certified FISCO power supply unit, a barrier or a power supply unit with linear characteristic curves and the following maximum values:

<b>Current circuit (terminal)</b>	<b>Electrical information (maximum values)</b>
Signal circuit	$U_i = 24 \text{ V}$
(+11 / -12) or (+ / -)	$I_i = 250 \text{ mA}$
	$P_i = 1.2 \text{ W}$
	Characteristic curve: linear

## ... 2 Use in potentially explosive atmospheres

### ... TZIDC-110 – Ex relevant specification

#### TZIDC-110 with Ex nA IIC T6 or T4 Gc marking

Current circuit (terminal)	System bus, computer interfaces
Signal circuit (+11 / -12)	U = 9 to 32 V DC I = 10.5 mA
Mechanical digital feedback (Limit1: +51 / -52) (Limit2: +41 / -42)	U = 5 to 11 V DC

#### Special conditions

- Devices must only be connected to circuits in zone 2 if they are suitable for operation in zone 2 potentially explosive atmospheres and for the conditions prevailing at the installation location (manufacturer's declaration or certificate from an inspection authority).
- For the 'digital feedback with proximity switches' circuit, external measures must be implemented to prevent the rated voltage from being exceeded by more than 40 % in the event of transient disturbances
- It is only permissible to connect, disconnect, and switch live circuits during installation or maintenance, or for the purpose of carrying out repairs.

#### Note

It is considered very unlikely that a potentially hazardous atmosphere would be present in zone 2 at the same time that installation or maintenance or repair work was being carried out.

- Only non-flammable gases must be used for pneumatic power supply.
- Only suited cable entries must be used that meet the requirements of EN 60079-15.

#### FM / CSA

#### CSA International

#### Certificate

Certificate 1649904 (LR 20312)

Class 2258 04 PROCESS CONTROL EQUIPMENT – Intrinsically Safe,  
Entity – For Hazardous Locations

Class 2258 02 PROCESS CONTROL EQUIPMENT  
–For Hazardous Locations

Class I, Div 2, Groups A, B, C and D;

Class II, Div 2, Groups E, F, and G,

Class III, Enclosure Type 4X:

#### Electrical data

#### Model TZIDC-110, P/N V18346-x032x2xx0x Intelligent Positioner

Input rated 32 V DC; max. 15 mA  
(powered by a SELV circuit)

#### Intrinsically safe with entity parameters of:

Terminals 11 / 12	U <sub>max.</sub> = 24 V I <sub>max.</sub> = 250 mA	C <sub>i</sub> = 2.8 nF L <sub>i</sub> = 7.2 uH
Terminals 85 / 86	U <sub>max.</sub> = 30 V I <sub>max.</sub> = 50 mA	C <sub>i</sub> = 3.8 nF L <sub>i</sub> = 0 uH
Terminals 41 / 42	U <sub>max.</sub> = 16 V I <sub>max.</sub> = 20 mA	C <sub>i</sub> = 60 nF L <sub>i</sub> = 100 uH
Terminals 51 / 52	U <sub>max.</sub> = 16 V I <sub>max.</sub> = 20 mA	C <sub>i</sub> = 60 nF L <sub>i</sub> = 100 uH

#### When installed per installation Drawing No 901265

Temperature code	T4
Max. Ambient temperature	85 °C

#### Note

- The 'x' in P/N denotes minor mechanical variations or optional features.
- Local communication interface (LCI) shall not be used in hazardous location.
- Each pair of conductors of each intrinsic safety circuit shall be shielded.
- See also **FM installation drawing No. 901265** on page 56.



**CSA certification record****Certificate**

Certificate	1649904 (LR 20312)
Class 2258 04	PROCESS CONTROL EQUIPMENT – Intrinsically Safe, Entity – For Hazardous Locations
Class I, Div 1, Groups A, B, C and D	
Class II, Div 1, Groups E, F, and G	
Class III, Div 1, Enclosure Type 4X	

**Electrical data****Model TZIDC-110, P/N V18346-x032x2xx0x Intelligent Positioner**

Input rated	32 V DC; max. 15 mA (powered by a SELV circuit)
-------------	--

**Intrinsically safe with entity parameters of:**

Terminals 11 / 12	$U_{max.} = 24 \text{ V}$ $I_{max.} = 250 \text{ mA}$	$C_i = 2.8 \text{ nF}$ $L_i = 7.2 \text{ uH}$
Terminals 85 / 86	$U_{max.} = 30 \text{ V}$ $I_{max.} = 50 \text{ mA}$	$C_i = 3.8 \text{ nF}$ $L_i = 0 \text{ uH}$
Terminals 41 / 42	$U_{max.} = 16 \text{ V}$ $I_{max.} = 20 \text{ mA}$	$C_i = 60 \text{ nF}$ $L_i = 100 \text{ uH}$

**When installed per installation Drawing No 901265**

Temperature code	T4
Max. ambient temperature	85 °C

**Note**

- The 'x' in P/N denotes minor mechanical variations or optional features.
- Local communication interface (LCI) shall not be used in hazardous location.
- Each pair of conductors of each intrinsic safety circuit shall be shielded.
- See also **FM installation drawing No. 901265** on page 56.

**FM approvals****TZIDC-110 Positioner, Model V18346-a032b2cd0e**

IS/I,II,III/1/ABCDEFG/T6,T5,T4

Ta = 40 °C, 55 °C, 85 °C-901265 Entity, FISCO

**Entity and FISCO Parameters**

Terminals	Type	Groups	Parameters	
+11 / -12	Entity	A-G	$U_{max.} = 24 \text{ V}$	$C_i = 2.8 \text{ nF}$
			$I_{max.} = 250 \text{ mA}$	$L_i = 7.2 \text{ uH}$
			$P_i = 1.2 \text{ W}$	
FISCO	A-G	A-G	$U_{max.} = 17.5 \text{ V}$	$C_i = 2.8 \text{ nF}$
			$I_{max.} = 360 \text{ mA}$	$L_i = 7.2 \text{ uH}$
			$P_i = 2.52 \text{ W}$	
FISCO	C-G	C-G	$U_{max.} = 17.5 \text{ V}$	$C_i = 2.8 \text{ nF}$
			$I_{max.} = 380 \text{ mA}$	$L_i = 7.2 \text{ uH}$
			$P_i = 5.32 \text{ nF}$	
+51 / -52	Entity	A-G	$U_{max.} = 16 \text{ V}$	$C_i = 60 \text{ nF}$
			$I_{max.} = 20 \text{ mA}$	$L_i = 100 \text{ uH}$
+41 / -42	Entity	A-G	$U_{max.} = 16 \text{ V}$	$C_i = 60 \text{ nF}$
			$I_{max.} = 20 \text{ mA}$	$L_i = 100 \text{ uH}$

NI/I/2/ABCD/T6,T5,T4 Ta = 40 °C, 55 °C, 85 °C

S/II,III/2/EFG//T6,T5,T4 Ta = 40 °C, 55 °C, 85 °C

Enclosure type 4x

- Case/mounting – 1, 2, 5 or 6
- Output/safe protection – 1, 2, 4 or 5
- Option modules – 0 or 4
- Optional mechanical kit for digital position feedback – 0, 1 or 3
- Design (varnish/coding) – 1 or E

## ... 2 Use in potentially explosive atmospheres

### ... TZIDC-110 – Ex relevant specification

**Equipment Ratings:**

TZIDC-110

Intrinsically safe, Entity and FISCO, for Class I, II and III,

Division 1,

Applicable Groups A, B, C, D, E, F, G; non-Incendive for Class I,

Division 2,

Group E, F and G hazardous (classified) indoor and outdoor

NEMA 4x locations.

The following temperature code ratings were assigned for the equipment and protection methods described above:

---

**Temperature code ratings**

---

T6 in ambient temperatures of 40 °C

---

T5 in ambient temperatures of 55 °C

---

T4 in ambient temperatures of 85 °C

---

See **FM installation drawing No. 901265** on page 56 for details.

## TZIDC-120 – Ex relevant specification

### Note

The values indicated here are taken from the respective certificates. Always observe the specifications and supplements in the explosion protection certificates.

### ATEX – ‘Ex i’ type of protection

Ex marking	
Marking	II 2 G Ex ia IIC T6 or T4 Gb II 3 G Ex ic IIC T6 or T4 Gc
Type Examination Test Certificate	TÜV 02 ATEX 1834 X
Type	Intrinsically safe equipment
Standards	EN 60079-0 EN 60079-11 EN 60079-27

### Temperature Data

Temperature class	Ambient temperature Ta
T4	-40 to 85 °C
T5	-40 to 55 °C
T6	-40 to 40 °C

### Electrical Data

#### ia / ib / ic for Grp. IIB / IIC

With the intrinsically safe Ex i IIC type of protection, only for connection to a certified FISCO power supply unit, a barrier or a power supply unit with linear characteristic curves and the following maximum values:

Current circuit (terminal)	Electrical information (maximum values)	
Signal circuit (+11 / -12 or + / -)	Ui = 24 V Ii = 250 mA Pi = 1.2 W	Characteristic curve: linear Li = < 10 µH Ci = < 5 nF

With intrinsic safety Ex ia IIC or Ex ib IIC type of protection, only for connection to a certified intrinsically safe circuit with the maximum values:

Current circuit (terminal)	Electrical information (maximum values)
Mechanical digital feedback (Limit1: +51 / -52) (Limit2: +41 / -42)	See EC type examination certificate PTB 00 ATEX 2049 X

### ATEX – ‘Ex n’ type of protection

Ex marking	
Marking	II 3 G Ex nA IIC T6 or T4 Gc
Type Examination Test Certificate	TÜV 02 ATEX 1943 X
Type	‘n’ type of protection
Device class	II 3 G
Standards	EN 60079-15 EN 60079-0

### Temperature Data

Device group II 3 G	
Temperature class	Ambient temperature Ta
T4	-40 to 85 °C
T6	-40 to 50 °C

### Electrical Data

Current circuit (terminal)	System bus, computer interfaces
Signal circuit (+11 / -12)	U = 9 to 32 V DC I = 11.5 mA
Mechanical digital feedback (Limit1: +51 / -52) (Limit2: +41 / -42)	U = 5 to 11 V DC

## ... 2 Use in potentially explosive atmospheres

### ... TZIDC-120 – Ex relevant specification

#### Special conditions

- Devices must only be connected to circuits in zone 2 if they are suitable for operation in zone 2 potentially explosive atmospheres and for the conditions prevailing at the installation location (manufacturer's declaration or certificate from an inspection authority).
- For the 'digital feedback with proximity switches' circuit, external measures must be implemented to prevent the rated voltage from being exceeded by more than 40 % in the event of transient disturbances
- It is only permissible to connect, disconnect, and switch live circuits during installation or maintenance, or for the purpose of carrying out repairs. Note: It is considered very unlikely that a potentially hazardous atmosphere would be present in zone 2 at the same time that installation or maintenance or repair work was being carried out.
- Only non-flammable gases may be used for the pneumatic power supply
- Only suited cable entries must be used that meet the requirements of EN 60079-15.

#### IECEx – 'Ex i' and 'Ex n' type of protection

Ex marking	
Marking	Ex ia IIC T6 or T4 Gb
	Ex ib IIC T6 or T4 Gb
	Ex ic IIC T6 or T4 Gc
	Ex nA IIC T6 or T4 Gc
Type Examination Test Certificate	IECEx TUN 04.0015X
Shown as	5
Type	Intrinsic safety 'I' or Type of protection 'n'
Standards	IEC 60079-0
	IEC 60079-11
	IEC 60079-15

#### Temperature Data

Temperature class	Ambient temperature Ta	
	TZIDC-120 Ex i IIC	TZIDC-120 Ex nA IIC
T4	-40 to 85 °C	-40 to 85 °C
T6	-40 to 40 °C	-40 to 50 °C

#### Electrical Data

##### TZIDC-120 for ia / ib / ic with Ex i IIC T6 or T4 Gb marking

With the intrinsically safe Ex i IIC type of protection, only for connection to a certified FISCO power supply unit, a barrier or a power supply unit with linear characteristic curves and the following maximum values:

Current circuit (terminal)	Electrical information (maximum values)
Signal circuit	U <sub>i</sub> = 24 V
(+11 / -12) or (+ / -)	I <sub>i</sub> = 250 mA
	P <sub>i</sub> = 1.2 W
	Characteristic curve: linear

**TZIDC-120 with Ex nA IIC T6 or T4 Gc marking**

Current circuit (terminal)	System bus, computer interfaces
Signal circuit (+11 / -12)	U = 9 to 32 V DC I = 11.5 mA
Mechanical digital feedback (Limit1: +51 / -52) (Limit2: +41 / -42)	U = 5 to 11 V DC

**Special conditions**

- Devices must only be connected to circuits in zone 2 if they are suitable for operation in zone 2 potentially explosive atmospheres and for the conditions prevailing at the installation location (manufacturer's declaration or certificate from an inspection authority).
- For the 'digital feedback with proximity switches' circuit, external measures must be implemented to prevent the rated voltage from being exceeded by more than 40 % in the event of transient disturbances
- It is only permissible to connect, disconnect, and switch live circuits during installation or maintenance, or for the purpose of carrying out repairs. Note: It is considered very unlikely that a potentially hazardous atmosphere would be present in zone 2 at the same time that installation or maintenance or repair work was being carried out.
- Only non-flammable gases may be used for the pneumatic power supply
- Only suited cable entries must be used that meet the requirements of EN 60079-15.

**FM / CSA****CSA International****Certificate**

Certificate	1649904 (LR 20312)
Class 2258 04	PROCESS CONTROL EQUIPMENT – Intrinsically Safe, Entity – For Hazardous Locations
Class 2258 02	PROCESS CONTROL EQUIPMENT – For Hazardous Locations

**Electric data****Model TZIDC-120, P/N V18347-x042x2xx0x Intelligent Positioner**

For use in	Class I, Div 2, Groups A, B, C and D; Class II, Div 2, Groups E, F, and G, Class III, Enclosure Type 4X
Input rated	32 V DC; max.15 mA (powered by a SELV circuit)

**Intrinsically safe with entity parameters of:**

Terminals 11 / 12	U max = 24 V I max = 250 mA	C <sub>i</sub> = 2.8 nF L <sub>i</sub> = 7.2 uH
Terminals 85 / 86	U max = 30 V I max = 50 mA	C <sub>i</sub> = 3.8 nF L <sub>i</sub> = 0 uH
Terminals 41 / 42	U max = 16 V I max = 20 mA	C <sub>i</sub> = 60 nF L <sub>i</sub> = 100 uH
Terminals 51 / 52	U max = 16 V I max = 20 mA	C <sub>i</sub> = 60 nF L <sub>i</sub> = 100 uH

**When installed per installation Drawing No 901265**

Temperature Code	T4
Max. Ambient temperature	85 °C

**Note**

- The 'x' in P/N denotes minor mechanical variations or optional features.
- Local communication interface (LCI) shall not be used in a hazardous location.
- Each pair of conductors of each intrinsic safety circuit shall be shielded.

## ... 2 Use in potentially explosive atmospheres

### ... TZIDC-120 – Ex relevant specification

#### CSA certification record

Certificate	
Certificate	1649904 (LR 20312)
Class 2258 04	PROCESS CONTROL EQUIPMENT – Intrinsically Safe, Entity – For Hazardous Locations

#### Electric data

##### Model TZIDC-120, P/N V18347-x042x2xx0x Intelligent Positioner

For use in Class I, Div 1, Groups A, B, C and D; Class II, Div 1, Groups E, F, and G, Class III, Div 1, Enclosure Type 4X

Input rated 32 V DC; max. 15 mA (powered by a SELV circuit)

##### Intrinsically safe with entity parameters of:

Terminals 11 / 12	U max = 24 V I max = 250 mA	C <sub>i</sub> = 2.8 nF L <sub>i</sub> = 7.2 uH
Terminals 85 / 86	U max = 30 V I max = 50 mA	C <sub>i</sub> = 3.8 nF L <sub>i</sub> = 0 uH
Terminals 41 / 42	U max = 16 V I max = 20 mA	C <sub>i</sub> = 60 nF L <sub>i</sub> = 100 uH

##### When installed per installation Drawing No 901265

Temperature Code	T4
Max. Ambient temperature	85 °C

#### Note

- The 'x' in P/N denotes minor mechanical variations or optional features.
- Local communication interface (LCI) shall not be used in a hazardous location.
- Each pair of conductors of each intrinsic safety circuit shall be shielded.

#### FM approvals

TZIDC-120 Positioner, Model V18347-a042b2cd0e IS/I,II,III/1/ABCDEFGH/T6,T5,T4  
Ta = 40 °C, 55 °C, 85 °C-901265 Entity, FISCO

#### Entity and FISCO Parameters

Terminals	Type	Groups	Parameters	
+11 / -12	Entity	A-G	U <sub>max</sub> = 24 V	C <sub>i</sub> = 2.8 nF
			I <sub>max</sub> = 250 mA	L <sub>i</sub> = 7.2 μH
			P <sub>i</sub> = 1.2 W	
	FISCO	A-G	U <sub>max</sub> = 17.5 V	C <sub>i</sub> = 2.8 nF
			I <sub>max</sub> = 360 mA	L <sub>i</sub> = 7.2 μH
			P <sub>i</sub> = 2.52 W	
	FISCO	C-G	U <sub>max</sub> = 17.5 V	C <sub>i</sub> = 2.8 nF
			I <sub>max</sub> = 380 mA	L <sub>i</sub> = 7.2 μH
			P <sub>i</sub> = 5.32 nF	
+51 / -52	Entity	A-G	U <sub>max</sub> = 16 V	C <sub>i</sub> = 60 nF
			I <sub>max</sub> = 20 mA	L <sub>i</sub> = 100 μH
+41 / -42	Entity	A-G	U <sub>max</sub> = 16 V	C <sub>i</sub> = 60 nF
			I <sub>max</sub> = 20 mA	L <sub>i</sub> = 100 μH

NNI/I/2/ABCD/T6,T5,T4 Ta = 40 °C, 55 °C, 85 °C  
S/II,III/2/EFG//T6,T5,T4 Ta = 40 °C, 55 °C, 85 °C  
Enclosure type 4x

- Case/mounting – 1, 2, 5 or 6
- Output/safe protection – 1, 2, 4 or 5
- Option modules – 0 or 4
- Optional mechanical kit for digital position feedback – 0, 1 or 3
- Design (varnish/coding) – 1 or E

#### Equipment Ratings

TZIDC-120 Positioners  
Intrinsically safe, Entity and FISCO, for Class I, II and III, Division 1, Applicable Groups A, B, C, D, E, F, G; non-incendive for Class I, Division 2, Group E, F and G hazardous (classified) indoor and outdoor NEMA 4x locations.

The following temperature code ratings were assigned for the equipment and protection methods described above:

#### Temperature code ratings

T6 in ambient temperatures of 40 °C

T5 in ambient temperatures of 55 °C

T4 in ambient temperatures of 85 °C

### 3 Product identification

#### Name plate

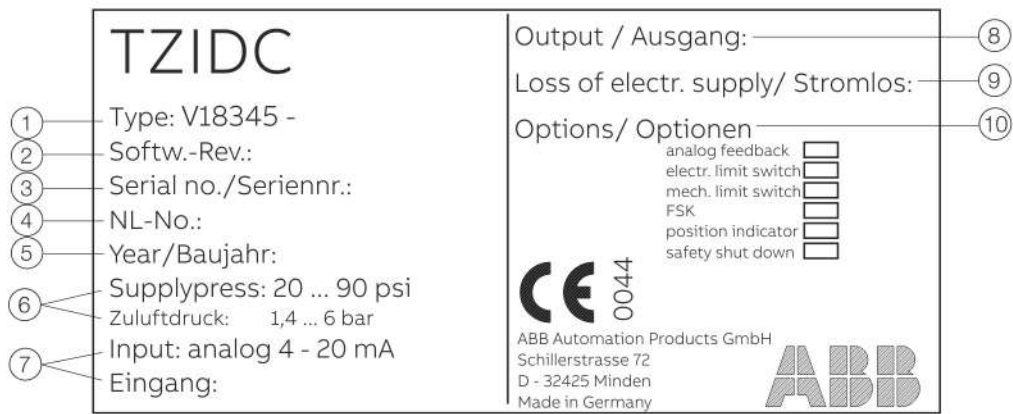

- ① Full type designation
- ② Software revision
- ③ Serial number
- ④ NL number
- ⑤ Year of manufacture

- ⑥ Supply air pressure
- ⑦ Input
- ⑧ Output
- ⑨ Dead
- ⑩ Options

Figure 1: Name plate (example)

## 4 Transport and storage

### Inspection

Check the devices immediately after unpacking for possible damage that may have occurred from improper transport. Details of any damage that has occurred in transit must be recorded on the transport documents. All claims for damages must be submitted to the shipper without delay and before installation.

### Transporting the device

Observe the following instructions:

- Do not expose the device to humidity during transport. Pack the device accordingly.
- Pack the device so that it is protected against vibrations during transport, for example, by using air-cushioned packing.

### Storing the device

Bear the following points in mind when storing devices:

- Store the device in its original packaging in a dry and dust-free location. The device is also protected by a desiccant in the packaging.
- The storage temperature should be between  $-40$  to  $85$  °C ( $-40$  to  $185$  °F).
- Avoid storing the device in permanent direct sunlight.
- In principle, the devices may be stored for an unlimited period. However, the warranty conditions stipulated in the order confirmation of the supplier apply.

### Ambient conditions

The ambient conditions for the transport and storage of the device correspond to the ambient conditions for operation of the device.

Adhere to the device data sheet!

### Returning devices

Use the original packaging or a secure transport container of an appropriate type if you need to return the device for repair or recalibration purposes.

Fill out the return form (see **Return form** on page 51) and include this with the device.

In accordance with the EU Directive governing hazardous materials, the owner of hazardous waste is responsible for its disposal or must observe the following regulations for shipping purposes:

All devices delivered to ABB must be free from any hazardous materials (acids, alkalis, solvents, etc.).

Please contact Customer Center Service acc. to page 4 for nearest service location.



## 5 Installation

### Safety instructions

#### CAUTION

##### **Risk of injury due to incorrect parameter values!**

Incorrect parameter values can cause the valve to move unexpectedly. This can lead to process failures and result in injuries.

- Before recommissioning a positioner that was previously in use at another location, always reset the device to its factory settings.
- Never start automatic adjustment before restoring the factory settings!

#### **Note**

Before assembly, check whether the positioner meets the control and safety requirements for the installation location (actuator or final control element).

Refer to the **Specification** in the data sheet.

Only qualified specialists who have been trained for these tasks are authorized to mount and adjust the unit, and to make the electrical connection.

When carrying out any work on the device, always observe the local accident prevention regulations and the regulations concerning the construction of technical installations.

## ... 5 Installation

### External position sensors

With TZIDC only!

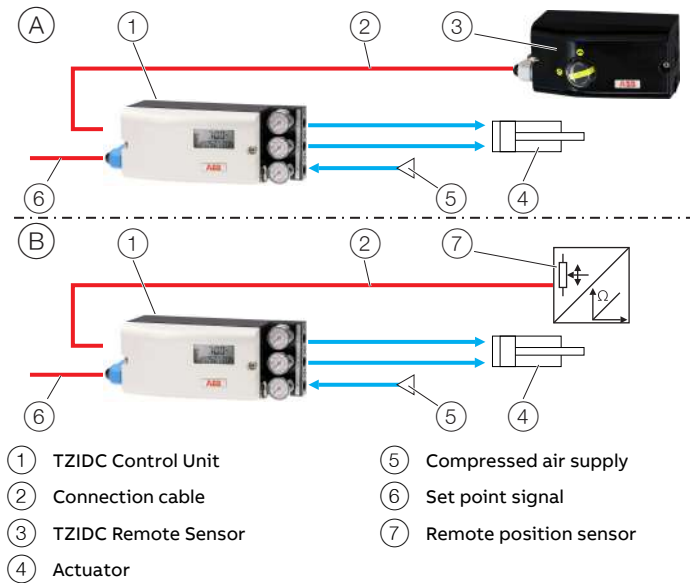

Figure 2: TZIDC with external position sensors

#### Note

If the device is being operated on a cylinder, for reasons associated with linearity you should run automatic adjustment for rotary actuators (refer to **Standard automatic adjustment** on page 46).

#### Ⓐ TZIDC Control Unit with TZIDC Remote Sensor\*

In this version, the components are supplied in two housings, which together form one harmonized unit.

The following points should be observed during installation:

- Housing 1 (TZIDC Control Unit) contains the electronics and pneumatics and is mounted separately from the actuator.
- Housing 2 (TZIDC Remote Sensor) contains the position sensor and is mounted on the linear and rotary actuator. Perform mechanical mounting as described in **Mechanical mounting** on page 27.
- The electrical connection is performed as described in **Connection on device - TZIDC Control Unit with TZIDC Remote Sensor** on page 40.

#### Note

To connect the TZIDC Remote Sensor, a cable with the following specifications needs to be used:

- 3-wire, cross-section 0.5 to 1.0 mm<sup>2</sup>
- shielded, with at least 85 % coverage
- Temperature range up to at least 100 °C (212 °F)

The cable glands must also be approved for a temperature range up to at least 100 °C (212 °F). The cable glands require a mounting for the shielding and strain relief for the cable in addition.

ABB optionally offers a cable gland and cable for the TZIDC Remote Version.

\* The TZIDC Remote Version is temporarily not available for the marine version.

#### Ⓑ TZIDC Control Unit for remote position sensor

In this version the positioner is supplied without a position sensor.

The following points should be observed during installation:

- Housing 1 (TZIDC Control Unit) contains the electronics and pneumatics and is mounted separately from the actuator.
- The remote position sensor is mounted on the linear and rotary actuator. Follow the operating instructions for the remote position sensor for mechanical mounting!
- The electrical connection is performed as described in **Connection on device - TZIDC Control Unit for remote position sensor** on page 41.

## Mechanical mounting

### General

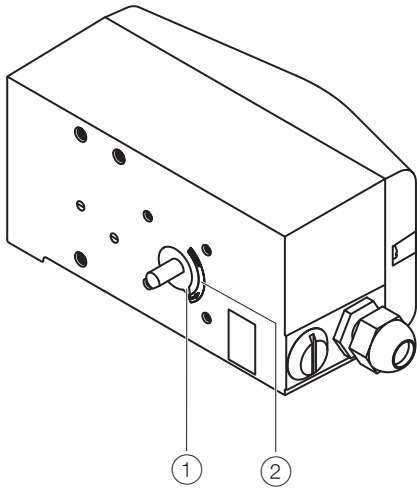

Figure 3: Operating range

Arrow ① on the device feedback shaft (position feedback point) must move between the arrow marks ②.

### Operating range of rotary actuators:

The usable span is 90°, which must be entirely within the measuring range, but does not necessarily need to run symmetrically to the longitudinal axis.

### Note

During installation make sure that the actuator travel or rotation angle for position feedback is implemented correctly.

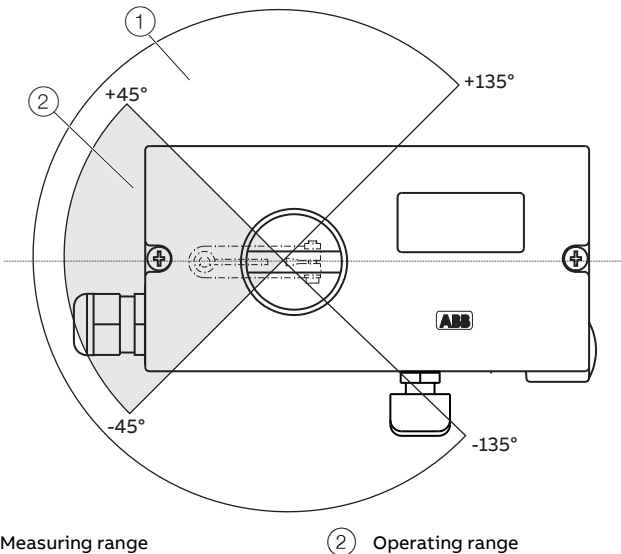

① Measuring range

② Operating range

Figure 4: Measuring and operating ranges of the positioner

### Operating range for linear actuators:

The operating range for linear actuators is  $\pm 45^\circ$  symmetrically to the longitudinal axis. The usable span within the operating range is at least 25° (recommended figure 40°). The usable span does not necessarily need to run symmetrically to the longitudinal axis.

## ... 5 Installation

### ... Mechanical mounting

#### Mounting on linear actuators

For mounting on a linear actuator in accordance with DIN / IEC 534 (lateral mounting as per NAMUR), the following attachment kit is available:

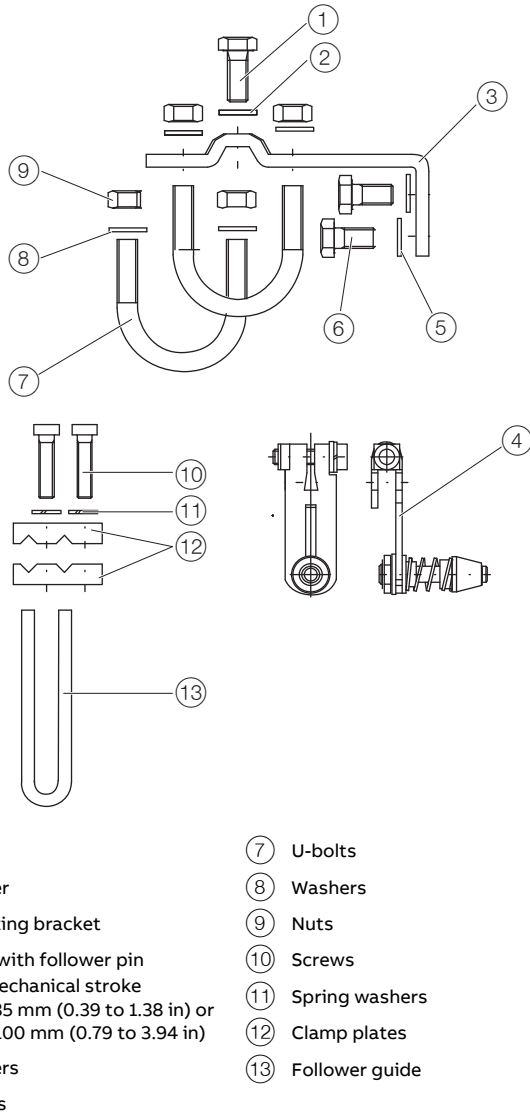

Figure 5: Attachment kit

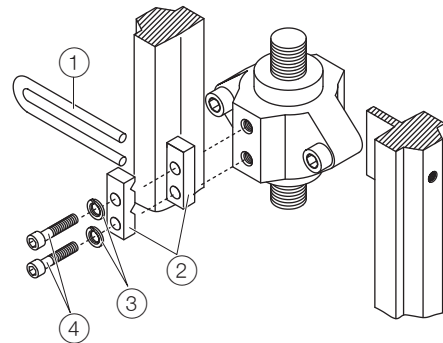

Figure 6: Attaching a follower guide to the actuator

1. Tighten the screws so that they are hand-tight.
2. Attach the follower guide ① and clamp plates ② with screws ④ and spring washers ③ to the actuator stem.

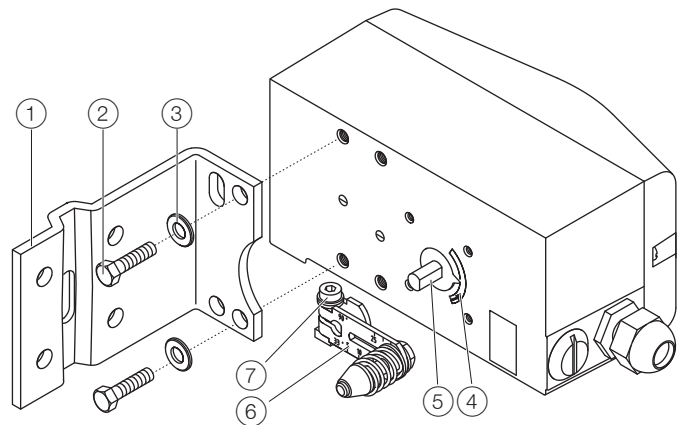

Figure 7: Mounting lever and bracket on the positioner

1. Attach the lever ⑥ to the feedback shaft ⑤ of the positioner (can only be mounted in one position due to the cut shape of the feedback shaft).
2. Using the arrow marks ④, check whether the lever moves within the operating range (between the arrows).
3. Hand-tighten the screw ⑦ on the lever.
4. Hold the prepared positioner (with the mount bracket ① still loose) on the actuator so that the follower pin for the lever enters the follower guide to determine which tap holes on the positioner must be used for the mount bracket.

- Secure the mount bracket ① with screws ② and washers ③ using the relevant tap holes on the positioner housing. Tighten the screws as evenly as possible to ensure subsequent linearity. Align the mount bracket in the oblong hole to ensure that the operating range is symmetrical (lever moves between the arrow marks ④).

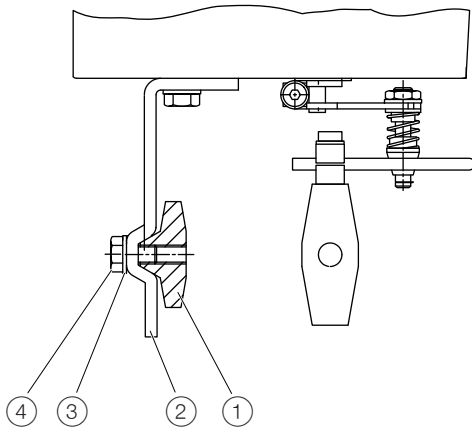

Figure 8: Mounting on a cast iron yoke

- Attach the mount bracket ② with screw ④ and washer ③ to the cast iron yoke ①.

or

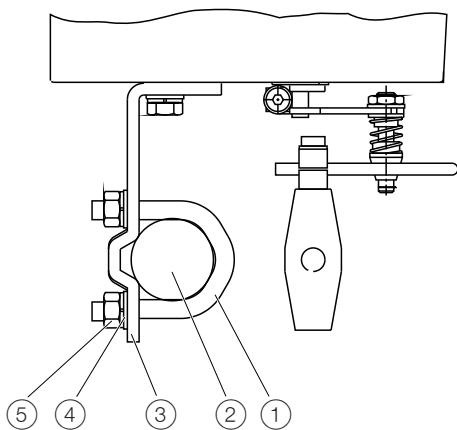
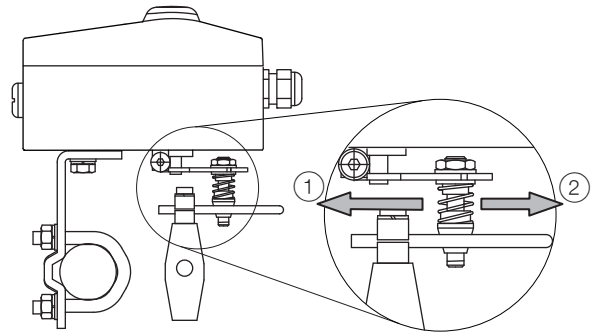

Figure 9: Mounting on a columnar yoke

- Hold the mount bracket ③ in the proper position on the columnar yoke ②.
- Insert the U-bolts ① from the inside of the columnar yoke ② through the holes of the mount bracket.
- Add the washers ④ and nuts ⑤.
- Tighten the nuts so that they are hand-tight.

#### Note

Adjust the height of the positioner on the cast iron yoke or columnar yoke until the lever is horizontal (based on a visual check) at half stroke of the valve.



① Increase linkage

② Decrease linkage

Figure 10: Positioner linkage

The scale on the lever indicates the link points for the various stroke ranges of the valve.

Move the bolt with the follower pin in the oblong hole of the lever to adjust the stroke range of the valve to the working range for the position sensor.

Moving the link point inwards increases the rotation angle of the sensor. Moving the link point outwards reduces the rotation angle of the sensor.

Adjust the actuator stroke to make use of as large an angle of rotation as possible (symmetrical around the center position) on the position sensor.

Recommended range for linear actuators:

- 28 to 28°

Minimum angle:

- 25°

#### Note

After mounting, check whether the positioner is operating within the measuring range.

## ... 5 Installation

### ... Mechanical mounting

#### Position of actuator bolt

The actuator bolt for moving the potentiometer lever can be mounted permanently on the lever itself or on the valve stem. Depending on the mounting method, when the valve moves the actuator bolt performs either a circular or a linear movement with reference to the center of rotation of the potentiometer lever. Select the chosen bolt position in the HMI menu in order to ensure optimum linearization. The default setting is actuator bolt on lever.

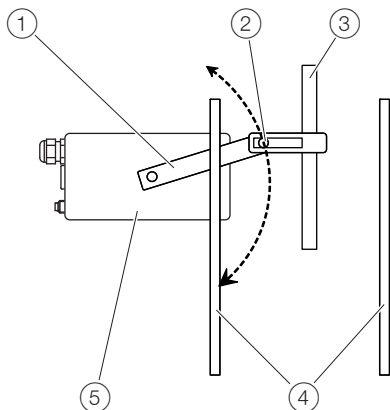

- ① Potentiometer lever
- ② Actuator bolts
- ③ Valve stem
- ④ Valve yoke
- ⑤ Positioner

Figure 11: Actuator bolts on the lever (rear view)

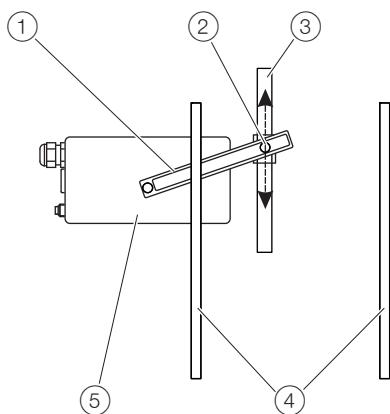

- ① Potentiometer lever
- ② Actuator bolts
- ③ Valve stem
- ④ Valve yoke
- ⑤ Positioner

Figure 12: Actuator bolts on the valve (rear view)

#### Mounting on rotary actuator

For mounting on part-turn actuators in accordance with VDI / VDE 3845, the following attachment kit is available:

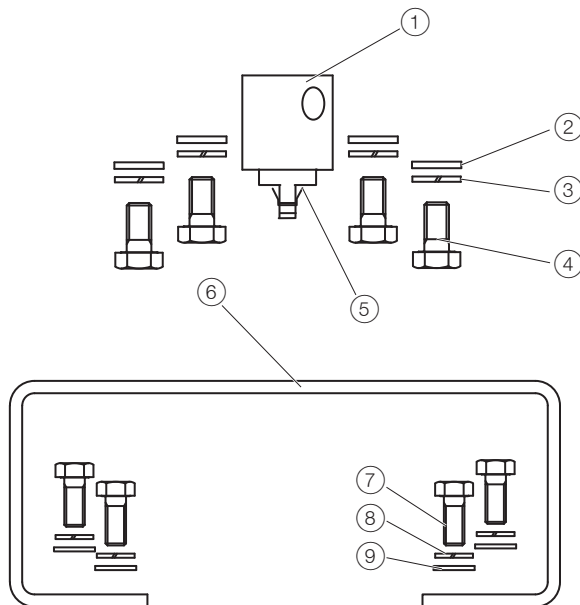

Figure 13: Components of attachment kit

- Adapter ① with spring ⑤
- four M6 screws each ④, spring washers ③ and washers ② to fasten the attachment bracket ⑥ to the positioner
- four M5 screws ⑦, Spring washers ⑧ and washers ⑨ to fasten the attachment bracket to the actuator

#### Required tools:

- Wrench, size 8 / 10
- Allen key, size 3

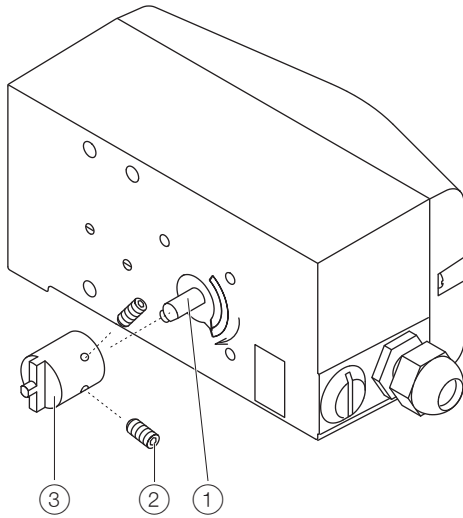
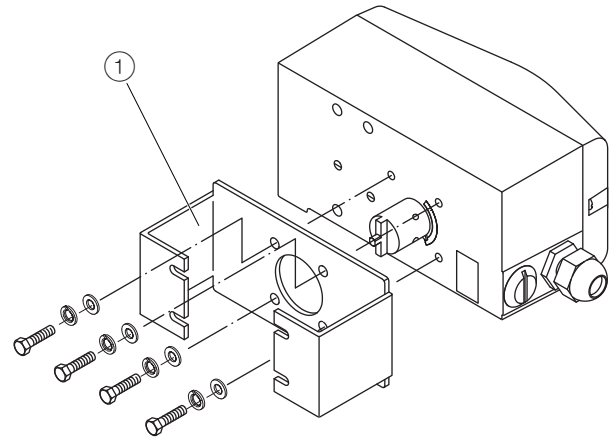

Figure 14: Mounting the adapter on the positioner

1. Determine the mounting position (parallel to actuator or at 90° angle)
2. Calculate the rotational direction of the actuator (right or left).
3. Move the part-turn actuator into the home position.
4. Pre-adjust feedback shaft.

To make sure that the positioner runs within the operating range (refer to **General** on page 27), the mounting position as well as the basic position and rotation direction of the actuator must be considered when determining the adapter position on axis ①. For this purpose, the feedback shaft can be adjusted manually so that the adapter ③ can be attached in the correct position.

5. Place the adapter in the proper position on the feedback shaft and fasten with threaded pins ②. One of the threaded pins must be locked in place on the flat side of the feedback shaft.



① Attachment bracket

Figure 15: Screwing the attachment bracket onto the positioner

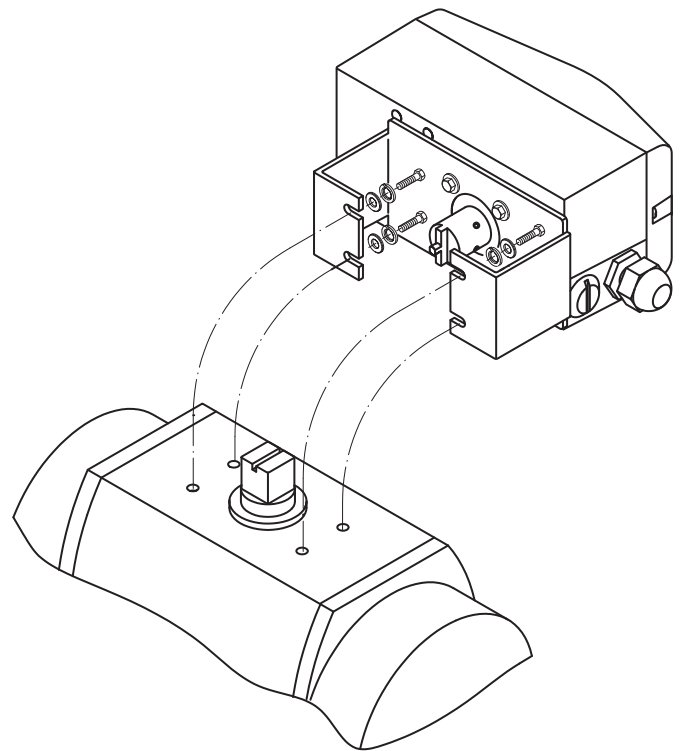

Figure 16: Screwing the positioner onto the actuator

#### Note

After mounting, check whether the operating range of the actuator matches the measuring range of the positioner, refer to **General** on page 27.

## 6 Electrical connections

### Safety instructions

#### **DANGER**

##### **Risk of explosion for devices with local communication interface (LCI)**

A local communication interface (LCI) may not be operated in hazardous areas.

- Never use the local communication interface (LCI) on the main board in a hazardous area!

#### **WARNING**

##### **Risk of injury due to live parts!**

When the housing is open, contact protection is not provided and EMC protection is limited.

- Before opening the housing, switch off the power supply.

The electrical connection may only be established by authorized specialist personnel.

Notices on electrical connection in this instruction must be observed; otherwise, electric safety and the IP-rating may be adversely affected.

Safe isolation of electric circuits which are dangerous if touched is only guaranteed when the connected devices fulfill the requirements of EN 61140 (basic requirements for secure separation).

To ensure safe isolation, install supply lines so that they are separate from electrical circuits which are dangerous if touched, or implement additional isolation measures for them.



## TZIDC / TZIDC Control Unit terminal assignment

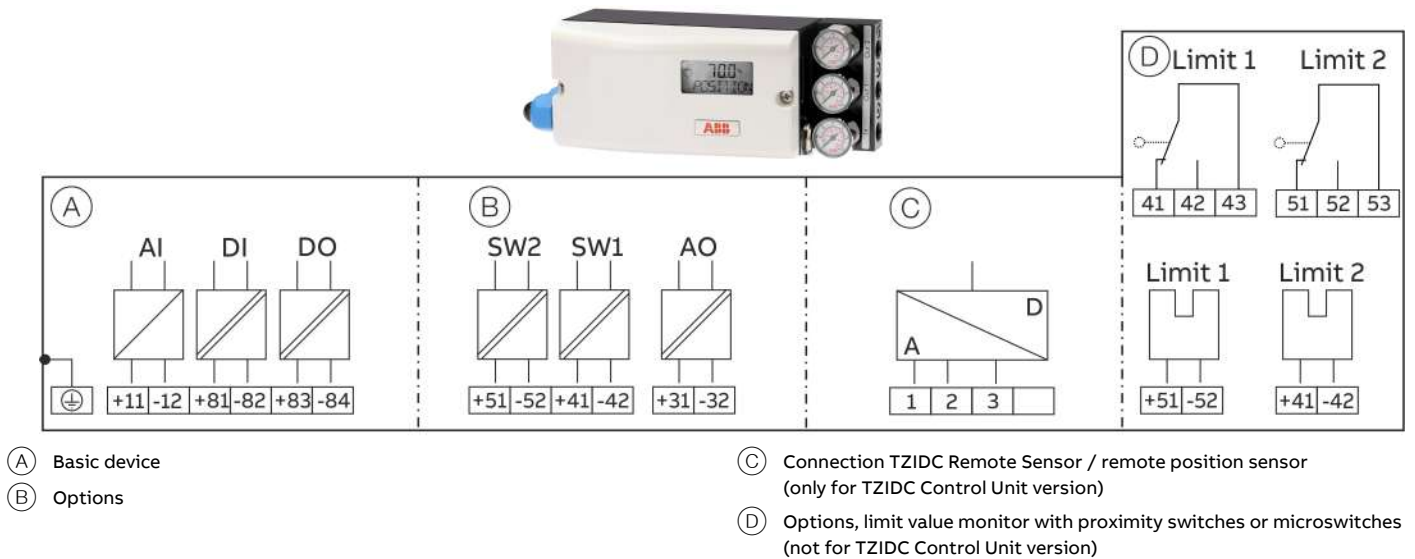

Figure 17: Control Unit connection diagram

### Connections for inputs and outputs

Terminal	Function / comments
+11 / -12	Analog input
+81 / -82	Binary input DI
+83 / -84	Binary output DO
+51 / -52	Digital feedback SW1 (Option module)
+41 / -42	Digital feedback SW2 (Option module)
+31 / -32	Analog feedback AO (Option module)
1 / 2 / 3	TZIDC remote sensor (Only for options TZIDC Remote Sensor or TZIDC for remote position sensor)

Terminal	Function / comments
+51 / -52	Limit switch Limit 1 with proximity switch (optional)
+41 / -42	Limit switch Limit 2 with proximity switch (optional)
41 / 42 / 43	Limit switch Limit 1 with microswitch (optional)
51 / 52 / 53	Limit switch Limit 2 with microswitch (optional)

#### Note

The TZIDC, TZIDC-110 or TZIDC-120 can be fitted either with proximity switches or microswitches as limit switches. It is not possible to combine both variants. For the version TZIDC Control Unit with TZIDC Remote Sensor, the limit switches are located in the TZIDC Remote Sensor.

## ... 6 Electrical connections

### TZIDC Remote Sensor terminal assignment

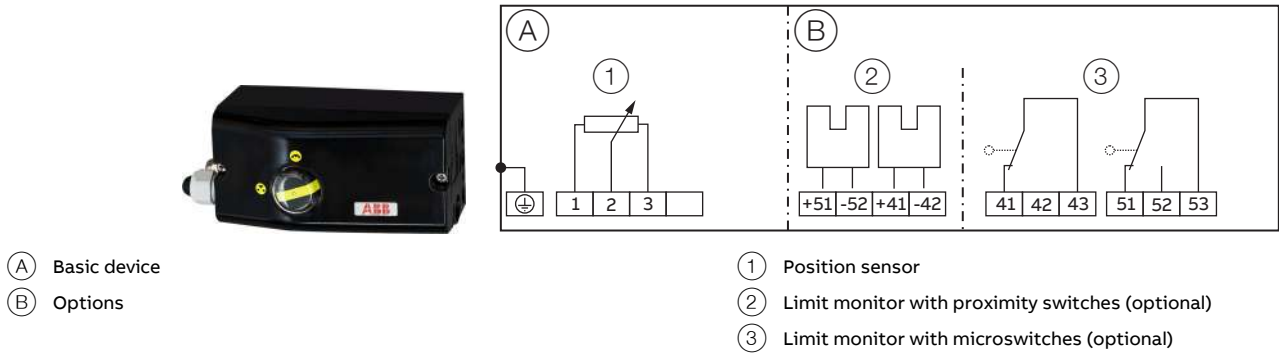

Figure 18: TZIDC Remote Sensor Electrical Connection

#### Connections for inputs and outputs

Terminal	Function / comments
1 / 2 / 3	TZIDC control unit
+51 / -52	Proximity switches Limit 1 (Option)
+41 / -42	Proximity switches Limit 2 (Option)
41 / 42 / 43	Microswitches Limit 1 (Option)
51 / 52 / 53	Microswitches Limit 2 (Option)

#### Note

The TZIDC Remote Sensor can be fitted either with proximity switches or microswitches as limit switches. It is not possible to combine both variants.

## TZIDC-110, TZIDC-120 terminal assignment

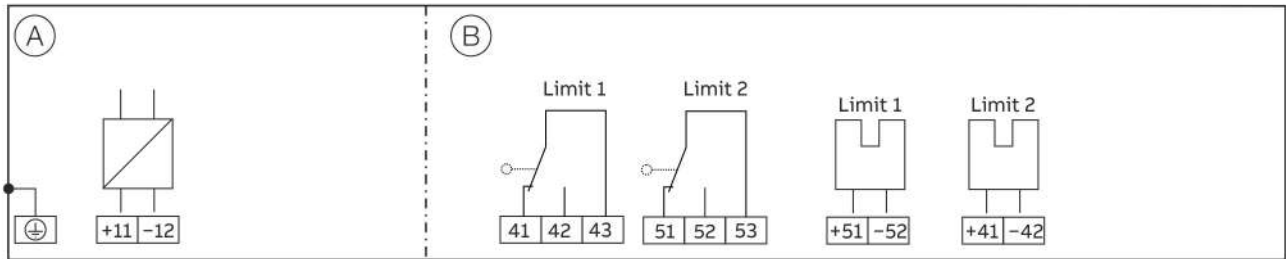

(A) Basic device

(B) Options, digital feedback with proximity switches or microswitches

Figure 19: TZIDC-110, TZIDC-120 electrical connection

Terminal	Function / comments
+11 / -12	Fieldbus, bus feed
+51 / -52	Digital feedback Limit 1 with proximity switch (optional)
+41 / -42	Digital feedback Limit 2 with proximity switch (optional)
41 / 42 / 43	Digital feedback Limit 1 with microswitch (optional)
51 / 52 / 53	Digital feedback Limit 2 with microswitch (optional)

### Note

The TZIDC-1x0, TZIDC-210 or TZIDC-220 can be fitted either with proximity switches or microswitches as limit switches. It is not possible to combine both variants.

## ... 6 Electrical connections

### Electrical data for inputs and outputs

**Note**

When using the device in potentially explosive atmospheres, note the additional connection data in **Use in potentially explosive atmospheres** on page 5!

**Analog input**

Only for devices with HART® Communication.

<b>Set point signal analog (two-wire technology)</b>	
Terminals	+11 / -12
Nominal operating range	4 to 20 mA
Split range configuration between	20 to 100 % of the nominal operating range can be parameterized
Maximum	50 mA
Minimum	3.6 mA
Starting at	3.8 mA
Load voltage	9.7 V at 20 mA
Impedance at 20 mA	485 Ω

**Fieldbus input**

Only for devices with PROFIBUS PA® or FOUNDATION Fieldbus® Communication.

<b>Bus Connection</b>	<b>PROFIBUS PA FOUNDATION fieldbus</b>	
Terminals	+11 / -12	+11 / -12
Supply voltage (Power feed from the Fieldbus)	9 to 32 V DC	9 to 32 V DC
Max. permissible voltage	35 V DC	35 V DC
Input Current	10.5 mA	11.5 mA
Current in the event of an error	15 mA (10.5 mA + 4.5 mA)	15 mA (11.5 mA + 3.5 mA)

**Digital input**

Only for devices with HART® Communication.  
Input for the following functions:

- no function
- move to 0 %
- move to 100 %
- Hold previous position
- block local configuration
- block local configuration and operation
- block any access (local or via PC)

<b>Binary input DI</b>	
Terminals	+81 / -82
Supply voltage	24 V DC (12 to 30 V DC)
Input 'logical 0'	0 to 5 V DC
Input 'logical 1'	11 to 30 V DC
Input Current	Maximum 4 mA

**Binary output**

Only for devices with HART® Communication.  
Output configurable as alarm output by software.

<b>Binary output DO</b>	
Terminals	+83 / -84
Supply voltage (Control circuit in accordance with DIN 19234/NAMUR)	5 to 11 V DC
Output 'logical 0'	> 0.35 mA to < 1.2 mA
Output 'logical 1'	> 2.1 mA
Direction of action	Configurable 'logical 0' or 'logical 1'

## Option modules

### Module for analog feedback AO\*

Only for devices with HART® Communication.

Without any signal from the positioner (e.g. 'no power' or 'initializing') the module sets the output to > 20 mA (alarm level).

Terminals	+31 / -32
Signal range	4 to 20 mA (Parameterization on split-ranges possible)
• in the event of an error	> 20 mA (alarm level)
Supply voltage, two-wire technology	24 V DC (11 to 30 V DC)
Characteristic curve	rising or falling (configurable)
Deviation	< 1 %

\* The module for analog feedback and the module for digital feedback have separate slots and can be used together.

### Module for digital feedback SW1, SW2\*

Only for devices with HART® Communication.

Terminals	+41 / -42, +51 / -52
Supply voltage	5 to 11 V DC (Control circuit in accordance with DIN 19234 / NAMUR)
Output 'logical 0'	< 1.2 mA
Output 'logical 1'	> 2.1 mA
Direction of action	Configurable 'logical 0' or 'logical 1'
Description	2 software switches for binary position feedback (position adjustable within the range of 0 to 100 %, ranges cannot overlap)

\* The module for analog feedback and the module for digital feedback have separate slots and can be used together.

### Assembly kits for digital feedback

Two proximity switches or microswitches for independent signaling of the actuator position, switching points are adjustable between 0 to 100%

#### Digital feedback with proximity switches Limit 1, Limit 2\*

Terminals	+41 / -42, +51 / -52
Supply voltage	5 to 11 V DC (Control circuit in accordance with DIN 19234/NAMUR)
Signal current < 1 mA	Switching state logical '0'
Signal current > 2 mA	Switching state logical '1'

#### Direction of action

Proximity switch	Actuator position			
	< Limit 1	> Limit 1	< Limit 2	> Limit 2
SJ2-SN (NC)	0	1	1	0

#### Digital feedback with 24 V-proximity switches Limit 1, Limit 2\*

Terminals	41 / 42 / 43 51 / 52 / 53
Supply voltage	maximum 24 V AC/DC
Load rating	Maximum 2 A
Contact surface	10 µm Gold (AU)

\* The proximity switches or 24 V microswitches for digital feedback are activated directly via the positioner axis and can only be used in combination with the optionally available mechanical position indicator.

#### Mechanical position indicator

Indicator disk in enclosure cover linked with device feedback shaft.

These options are also available for retrofitting by Service.

## ... 6 Electrical connections

### Connection on the device

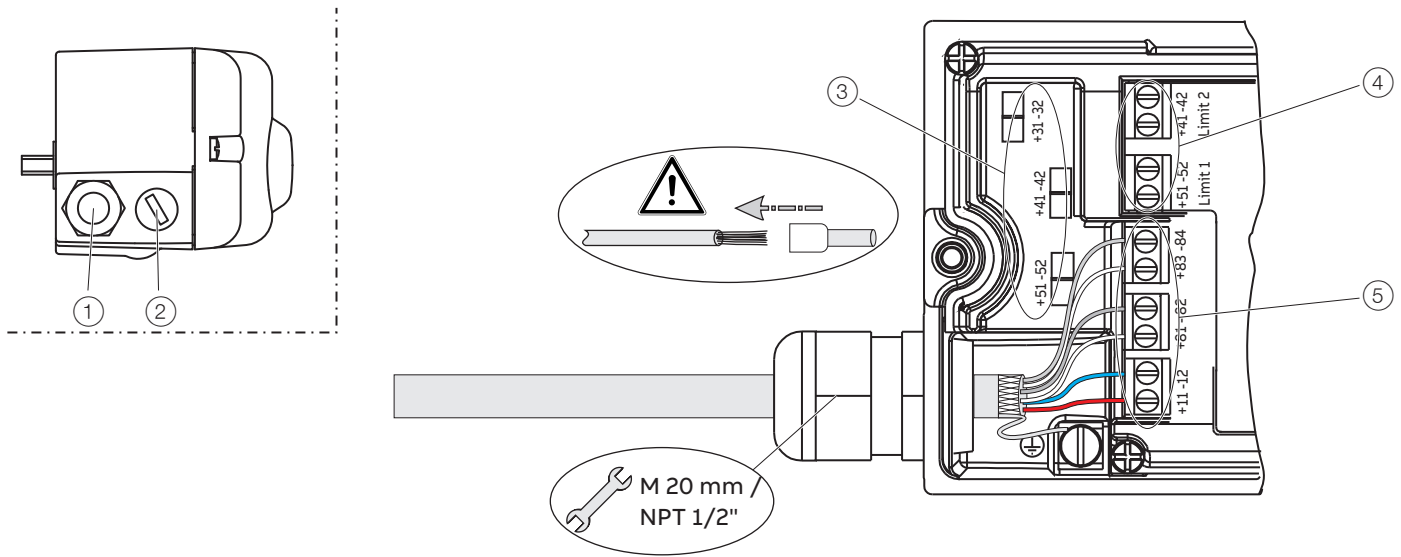

- ① Cable gland
- ② Blind plug
- ③ Terminals for option modules
- ④ Terminal attachment kit for digital feedback
- ⑤ Terminals for basic unit

Figure 20: Connection to device (example)

2 tap holes 1/2- 14 NPT or M20 × 1.5 are provided on the left side of the housing for cable entry in the housing. One of the tap holes is fitted with a cable gland, while the other tap hole has a blind plug.

**Note**

The connecting terminals are delivered closed and must be unscrewed before inserting the wire.

1. Strip the wires to approximately 6 mm (0.24 in).
2. Connect the wires to the connecting terminals in line with the connection diagram.

## Conductor cross-section

### Basic device

#### Electrical connections

4 to 20 mA input	Screw terminals max. 2.5 mm <sup>2</sup> (AWG14)
Options	Screw terminals max. 1.0 mm <sup>2</sup> (AWG18)

#### Cross section

Rigid / flexible wires	0.14 to 2.5 mm <sup>2</sup> (AWG26 to AWG14)
Flexible with wire end sleeve	0.25 to 2.5 mm <sup>2</sup> (AWG23 to AWG14)
Flexible with wire end sleeve no plastic sleeve	0.25 to 1.5 mm <sup>2</sup> (AWG23 to AWG17)
Flexible with wire end sleeve with plastic sleeve	0.14 to 0.75 mm <sup>2</sup> (AWG26 to AWG20)

#### Multi-wire connection capacity (two wire with the same cross-section)

Rigid / flexible wires	0.14 to 0.75 mm <sup>2</sup> (AWG26 to AWG20)
Flexible with wire end sleeve no plastic sleeve	0.25 to 0.75 mm <sup>2</sup> (AWG23 to AWG20)
Flexible with wire end sleeve with plastic sleeve	0.5 to 1.5 mm <sup>2</sup> (AWG21 to AWG17)

## Option modules

### Cross section

Rigid / flexible wires	0.14 to 1.5 mm <sup>2</sup> (AWG26 to AWG17)
Flexible with wire end sleeve no plastic sleeve	0.25 to 1.5 mm <sup>2</sup> (AWG23 to AWG17)
Flexible with wire end sleeve with plastic sleeve	0.25 to 1.5 mm <sup>2</sup> (AWG23 to AWG17)

### Multi-wire connection capacity (two wire with the same cross-section)

Rigid / flexible wires	0.14 to 0.75 mm <sup>2</sup> (AWG26 to AWG20)
Flexible with wire end sleeve no plastic sleeve	0.25 to 0.5 mm <sup>2</sup> (AWG23 to AWG22)
Flexible with wire end sleeve with plastic sleeve	0.5 to 1 mm <sup>2</sup> (AWG21 to AWG18)

### Limit switch with proximity switches or 24 V microswitches

Rigid wire	0.14 to 1.5 mm <sup>2</sup> (AWG26 to AWG17)
Flexible wire	0.14 to 1.0 mm <sup>2</sup> (AWG26 to AWG18)
Flexible with wire end sleeve no plastic sleeve	0.25 to 0.5 mm <sup>2</sup> (AWG23 to AWG22)
Flexible with wire end sleeve with plastic sleeve	0.25 to 0.5 mm <sup>2</sup> (AWG23 to AWG22)

## ... 6 Electrical connections

### ... Connection on the device

#### Connection on device - TZIDC Control Unit with TZIDC Remote Sensor

TZIDC Control Unit

TZIDC remote sensor

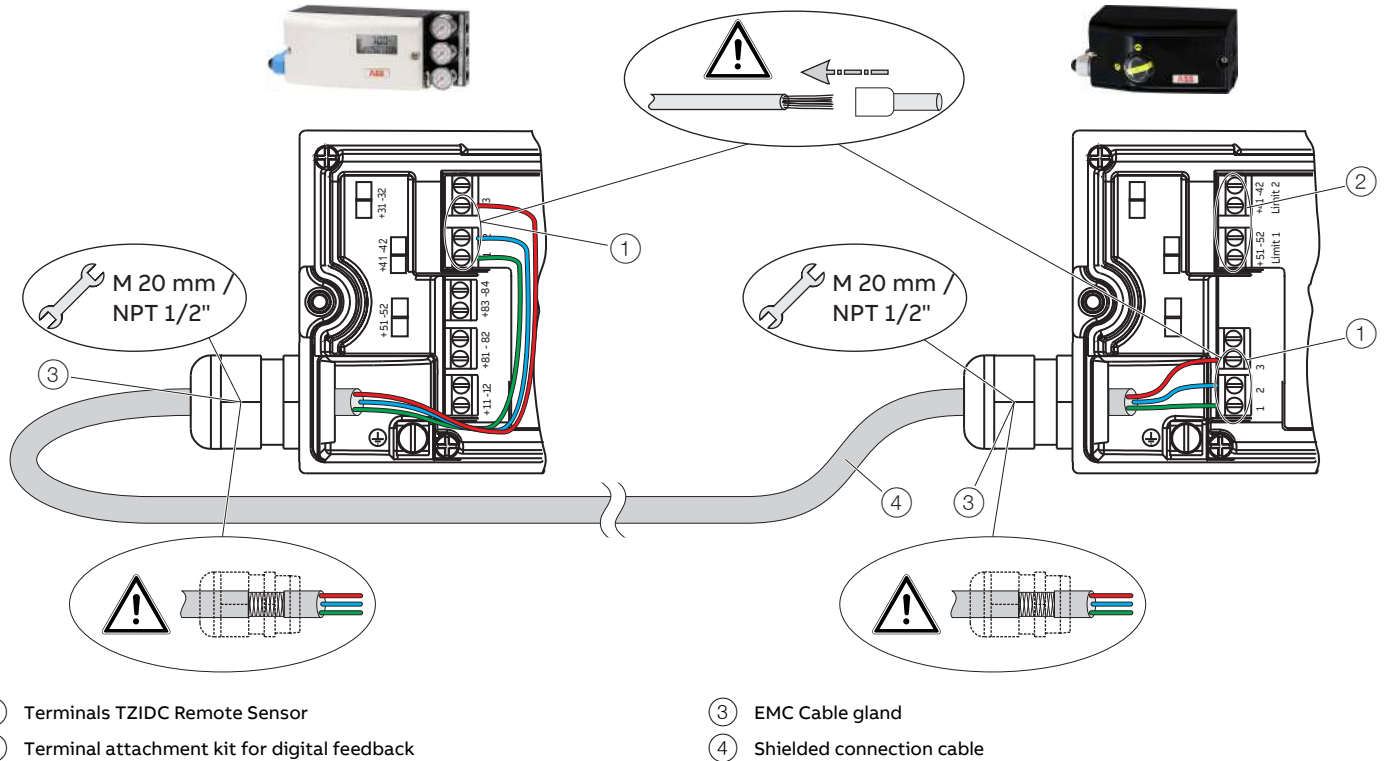

- ① Terminals TZIDC Remote Sensor
- ② Terminal attachment kit for digital feedback
- ③ EMC Cable gland
- ④ Shielded connection cable

Figure 21: Connection of TZIDC Control Unit with TZIDC Remote Sensor (example)

In the case of the ‘TZIDC Control Unit with TZIDC Remote Sensor’ design, the components are supplied in two housings, which together form one harmonized unit.

**Housing 1** (TZIDC Control Unit) contains the electronics and pneumatics along with the following options, where applicable:

- Analog position feedback
- Digital position feedback

**Housing 2** (TZIDC Remote Sensor) contains the position sensor and allows for mounting on linear or rotary actuators.

If necessary, the following options can be installed if required:

- Optical position indicator
- Mechanical feedback contacts designed as proximity switches or microswitches.

Connect the positioner (TZIDC Control Unit, housing 1) and remote position sensor (TZIDC Remote Sensor, housing 2) while following the instructions below:

- The sensor and the electronics have been matched. Ensure that only devices with the same serial number are connected.

- A shielded 3-wire cable with a maximum length of 10 m (33 ft) must be used for the connection.
- Route the cable into the terminal compartment through the EMC cable glands. Ensure that the shielding is secured correctly in the EMC cable glands.
- Connect the cables in accordance with the electrical connections and tighten the screws of the terminals so that they are hand-tight.
- The electrical connection of the TZIDC Control Unit and the optional modules are described in **TZIDC / TZIDC Control Unit terminal assignment** on page 33.
- If the TZIDC Control Unit is fastened so that it is non-conductive, the housing must be grounded (TZIDC Control Unit and TZIDC Remote Sensor housing with the same electric potential); otherwise control deviations could occur with regard to analog position feedback.
- Use wire end ferrules when connecting.



## Connection on device - TZIDC Control Unit for remote position sensor

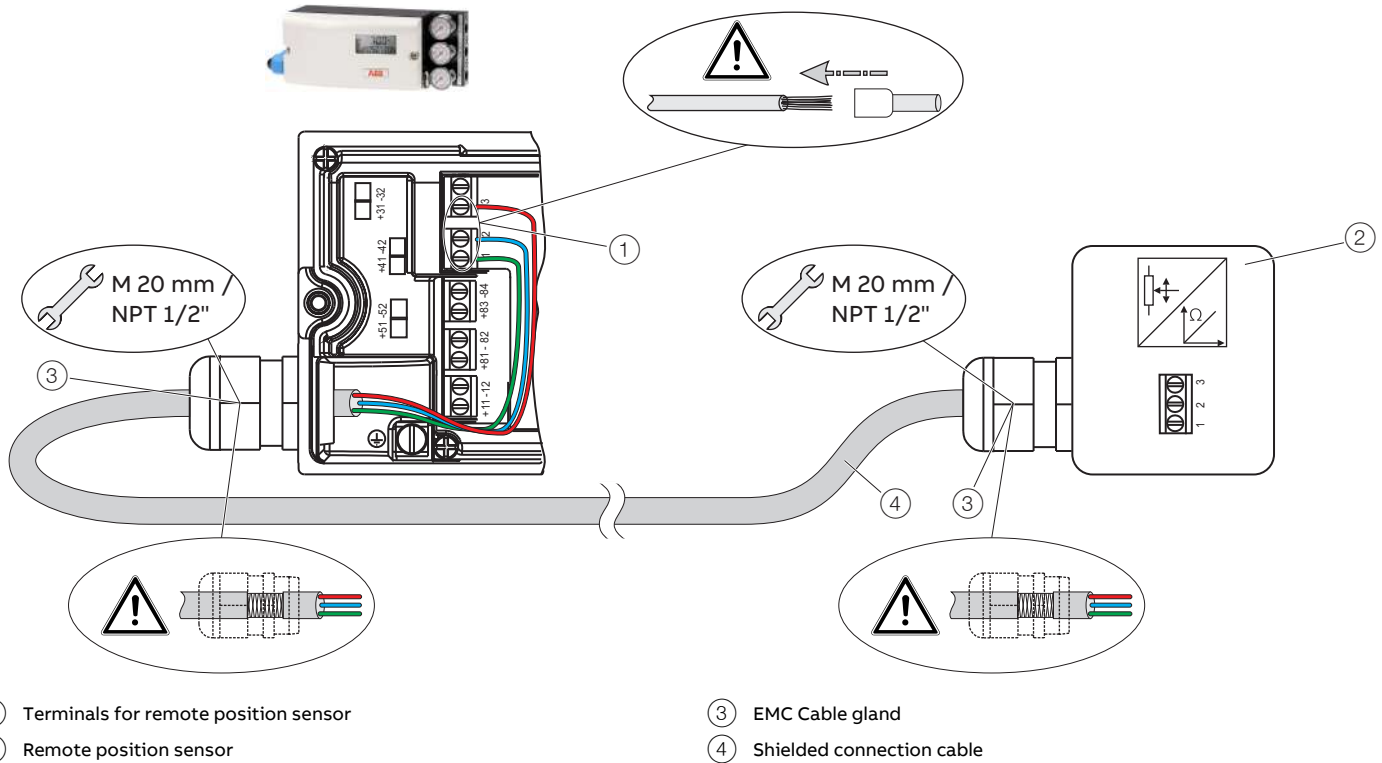

Figure 22: Connection of TZIDC Control Unit with remote position sensor (example)

With the TZIDC designed for remote position sensors, the positioner is supplied without a position sensor.

The housing (TZIDC Control Unit) contains the electronics and pneumatics along with the following options, where applicable:

- Analog position feedback
- Digital position feedback

Any position sensor (4 to 30 k $\Omega$ , with line break detection 4 to 18 k $\Omega$ ) can be connected.

Connect the positioner (TZIDC Control Unit) and remote position sensor while observing the following instructions:

- A shielded 3-wire cable with a maximum length of 10 m (33 ft) must be used for the connection.
- Route the cable into the terminal compartment through the EMC cable glands. Ensure that the shielding is secured correctly in the EMC cable glands.
- Connect the cables in accordance with the electrical connections and tighten the screws of the terminals so that they are hand-tight.
- The electrical connection of the TZIDC Control Unit and the optional modules are described in **TZIDC / TZIDC Control Unit terminal assignment** on page 33.
- If the TZIDC Control Unit is fastened such that it is non-conductive, the housing must be grounded (TZIDC Control Unit and remote position sensor housing with the same electric potential); otherwise control deviations could occur with regard to analog position feedback.
- Use wire end ferrules when connecting.
- The pneumatic outputs must be connected to the actuator using cables of at least  $\varnothing$  6 mm (0.23 in).
- If the device is being operated on a cylinder, for reasons associated with linearity you should run automatic adjustment for rotary actuators.

## 7 Pneumatic Connections

### Note

The positioner must only be supplied with instrument air that is free of oil, water, and dust.

The purity and oil content must meet the requirements of Class 3 in accordance with DIN/ISO 8573-1.

### NOTICE

#### Damage to components!

Contamination on the air pipe and positioner can damage components.

- Dust, splinters, and any other particles of dirt must be blown-out before the pipe is connected.

### NOTICE

#### Damage to components!

Pressure above 6 bar (90 psi) can damage the positioner or actuator.

- Provisions must be made (e.g. by using a pressure reducer) to make sure that the pressure does not rise above 6 bar (90 psi)\*, even in the event of a fault.

\* 5.5 bar (80 psi) (marine version)

### Information on double acting actuators with spring-return mechanism

On double-acting actuators with spring-return mechanism, a pressure that significantly exceeds the supply air pressure value can be generated during operation by the springs in the chamber opposite the springs.

This may damage the positioner or adversely affect control of the actuator.

To eliminate the possibility of this occurring, it is recommended to install a pressure compensation valve between the springless chamber and the supply air for these types of applications. It enables the increased pressure to be transferred back to the air inlet line.

The opening pressure of the check valve should be < 250 mbar (< 3.6 psi).

### Connection on the device

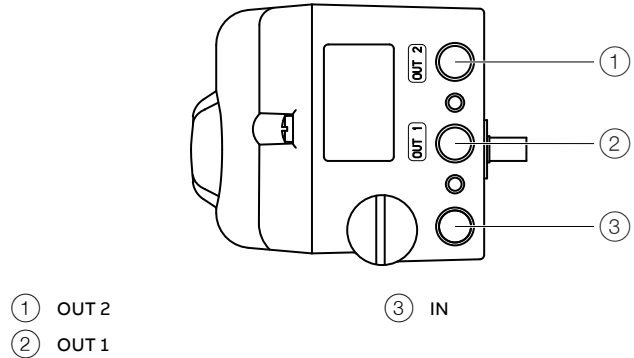

Figure 23: Pneumatic connections

Marking	Pipe connection
IN	Supply air, pressure 1.4 to 6 bar (20 to 90 psi) Marine version: <ul style="list-style-type: none"> <li>• Supply air, pressure 1.4 to 5.5 bar (20 to 80 psi)**</li> </ul>
OUT1	Output pressure to the actuator
OUT2	Output pressure to the actuator (2. Connection with double acting actuator)

\*\* (marine version)

Join the pipe connections according to the designation, observing the following points:

- All pneumatic piping connections are located on the right-hand side of the positioner. G $\frac{1}{4}$  or  $\frac{1}{4}$  18 NPT tap holes are provided for the pneumatic connections. The positioner is labeled according to the tap holes available.
- We recommend that you use a pipe with dimensions of 12 x 1.75 mm.
- The supply air pressure required to apply the actuating force must be adjusted in line with the output pressure in the actuator. The operating range of the positioner is between 1.4 to 6 bar (20 to 90 psi)\*\*\*.

\*\*\* 1.4 to 5.5 bar (20 to 80 psi) marine version

## Air supply

Instrument air*	
Purity	Maximum particle size: 5 µm Maximum particle density: 5 mg/m <sup>3</sup>
Oil content	Maximum concentration 1 mg/m <sup>3</sup>
Pressure dew point	10 K below operating temperature
Supply pressure**	Standard design: 1.4 to 6 bar (20 to 90 psi) Marine version: 1.6 to 5.5 bar (23 to 80 psi)
Air consumption***	< 0.03 kg/h / 0.015 scfm

\* Free of oil, water and dust in accordance with DIN / ISO 8573-1. Pollution and oil content in accordance with Class 3

\*\* Do not exceed the maximum output pressure of the actuator

\*\*\* Independent of supply pressure

## 8 Commissioning

### Note

The electrical power supply and supply air pressure data indicated on the name plate must be complied with during commissioning.

### CAUTION

#### Risk of injury due to incorrect parameter values!

Incorrect parameter values can cause the valve to move unexpectedly. This can lead to process failures and result in injuries.







- Before recommissioning a positioner that was previously in use at another location, always reset the device to its factory settings.
- Never start automatic adjustment before restoring the factory settings!

### Note

Please observe the information in **Operation** on page 49 to operate the device!

## TZIDC

Commissioning the positioner:

1. Open the pneumatic power supply.
2. Power-up the electric power supply and feed in the setpoint signal 4 to 20 mA.
3. Checking mechanical mounting:
  - Press and hold **MODE**; in addition, press  or  until operating mode 1.3 (manual adjustment in the measuring range) is displayed. Release **MODE**.
  - Press  or  to move the actuator into the mechanical end position; check the end positions; rotational angle is displayed in degrees; for high-speed mode, press  or  simultaneously.

### Recommended rotational angle range

Linear actuators	-28 to 28°
Rotary actuators	-57 to 57°
Minimum angle	25°

4. Perform standard automatic adjustment in accordance with **Standard automatic adjustment** on page 46.

Commissioning of the positioner is now complete, and the device is ready for operation.

## ... 8 Commissioning

### ... TZIDC

#### Operating modes

Selection from the operating level

1. Press and hold down **MODE**.
2. Also press and release **↑** rapidly as often as required. The selected operating mode is displayed.
3. Release **MODE**.

The position is displayed in % or as a rotation angle.

Operating mode	Mode indicator	Position indicator
1.0 Control mode* with adaptation of the control parameters		
1.1 Control mode* without adaptation of the control parameters		
1.2 Manual adjustment** in the operating range. Adjust*** using <b>↑</b> or <b>↓</b>		
1.3 Manual adjustment** in the measuring range. Adjust*** using <b>↑</b> or <b>↓</b>		

\* Since self-optimization in operating mode 1.0 is subject to several factors during control operation with adaptation, incorrect adjustments could appear over an extended period.

\*\* Positioning not active.

\*\*\* For high-speed mode, press **↑** and **↓** simultaneously.

### TZIDC-110 / TZIDC-120

Commissioning the positioner:

1. Open the pneumatic power supply.
2. Connect fieldbus or power supply to the bus connections.

The following is now shown in the display:



3. Checking mechanical mounting:
  - Press and hold down **MODE** and **ENTER**; once the countdown has gone from 3 to 0, release **MODE** and **ENTER**. The device switches to the operating level n operating mode 1.x.
  - Press and hold **MODE** and **ENTER**, and then press **↑** or **↓** until operating mode 1.3 (manual adjustment within the sensor range) is displayed. Release **MODE**.
  - Press **↑** or **↓** to move the actuator into the mechanical end position; check the end positions; rotation angle is displayed in degrees; for high-speed mode, press **↑** or **↓** simultaneously.

#### Recommended rotational angle range

Linear actuators	-28 to 28°
Rotary actuators	-57 to 57°
Minimum angle	25°

4. Go back to the bus level:
  - Press and hold down **MODE** and **ENTER**; once the countdown has gone from 3 to 0, release **MODE** and **ENTER**.

The following is now shown in the display:



5. Perform standard automatic adjustment in accordance with **Standard automatic adjustment** on page 46. Make sure the device is on the bus level (REMOTE).
6. Set dead zone and tolerance band. This step is only required for critical (e.g. very small) actuators. In normal cases you can skip this step.

Commissioning of the positioner is now complete, and the device is ready for operation.

## Setting the bus address

- Switching to the configuration level:
  - Press and hold down **↑** and **↓** simultaneously,
  - additionally quickly press and release **ENTER**,
  - Wait for the countdown to go from 3 to 0,
  - Release **↑** and **↓**.

The following is now shown in the display:



- Switch to parameter group 1.5:
  - Press and hold down **MODE** and **ENTER** simultaneously,
  - additionally, press **↑** and **↓**.

The following is now shown in the display:



- Release **MODE**.

The following is now shown in the display:



- Setting the bus address:
  - Press **↑** or **↓** to set the correct value,
  - Press and hold down **ENTER** until the countdown goes from 3 to 0.
  - Release **ENTER**.

The new bus address is saved.

- Switch to parameter 1.6 (return to operating level) and save the new setting:

- Press and hold down **MODE**,
- additionally quickly press **↑** 2 times,

The following is now shown in the display:





- Release **MODE**,
- Quickly press and release **↑** to select **NV\_SAVE**,
- Press and hold down **ENTER** until the countdown goes from 3 to 0.

The new parameter setting is saved and the positioner automatically returns to the operating level. It continues in the operating mode that was active prior to the configuration level being called up.

## Request information

When the device is in bus operation, the information listed below can be called up.

Press the following control buttons to access this information:

Control buttons	Action
	Cyclic communication: Set point in % and the set point status is displayed.
	Acyclic communication: Displays the communication status. Displays the bus address and operating mode.
<b>Enter</b> 	Displays the software revision.

## ... 8 Commissioning







### ... TZIDC-110 / TZIDC-120

#### Operating modes

Selection from the operating level:

1. Press and hold down **MODE**.
2. Also press and release **↑** rapidly as often as required. The selected operating mode is displayed.
3. Release **MODE**.

The position is displayed in % or as a rotation angle.

Operating mode	Mode indicator	Position indicator
1.1 Positioning with fixed set point. Adjust set point by using <b>↑</b> or <b>↓</b> .		
1.2 Manual adjustment* in the operating range. Adjust with <b>↑</b> or <b>↓</b> **		
1.3 Manual adjustment* within the sensor range. Adjust with <b>↑</b> or <b>↓</b> **		

\* Positioning not active.

\*\* For high-speed mode, press **↑** and **↓** simultaneously.

#### Jumper configuration

Only on TZIDC-120

There are two jumpers on the mainboard that can be used to activate or block simulation mode and write access.

Set the jumpers as shown below:

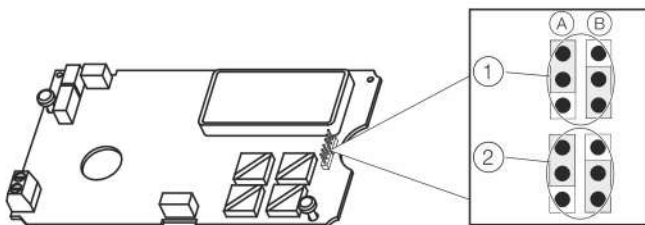

Figure 24: TZIDC-120 jumpers

Jumper	Number	Function
①	A	Simulation blocked*
	B	Simulation enabled
②	A	Write access blocked
	B	Write access activated*

\* Default setting (in accordance with Fieldbus Foundation standard)

### Standard automatic adjustment

#### Note

Standard Auto Adjust does not always result in optimum control conditions.

#### Standard automatic adjustment for linear actuators\*

1. **MODE** Press and hold until **ADJ\_LIN** is displayed.
2. **MODE** Press and hold until the countdown ends.
3. Release **MODE**; this starts Autoadjust.

#### Standard automatic adjustment for rotary actuators\*

1. **ENTER** Press and hold until **ADJ\_ROT** is displayed.
2. **ENTER** Press and hold until the countdown ends.
3. Release **ENTER**; this starts Autoadjust.

If Autoadjust is successful, the parameters will be stored automatically and the positioner will revert to operating mode 1.1.

If an error occurs during Autoadjust, the process will be terminated with an error message.

Perform the following steps if an error occurs:

1. Press and hold down operating button **↑** or **↓** for approximately three seconds.

The unit will switch to the operating level, mode 1.3 (manual adjustment within the measuring range).

2. Check mechanical mounting in accordance with **Mechanical mounting** on page 27 and repeat the standard automatic adjustment.

\* The zero position is determined automatically and saved during standard automatic adjustment, counter-clockwise (CTCLOCKW) for linear actuators and clockwise (CLOCKW) for rotary actuators.

## Sample parameters

### 'Change the zero position of the LCD display from clockwise (CLOCKW) to counter-clockwise limit stop (CTCLOCKW)'

Initial situation: the positioner is in bus operation on the operating level.

- Switching to the configuration level:
  - Press and hold down  $\uparrow$  and  $\downarrow$  simultaneously,
  - additionally quickly press and release **ENTER**,
  - Wait for the countdown to go from 3 to 0,
  - Release  $\uparrow$  and  $\downarrow$ .

The following is now shown in the display:



- Switching to parameter group 3.1:
  - Press and hold down **MODE** and **ENTER** simultaneously,
  - additionally quickly press and release  $\uparrow$  2x,
 The following is now shown in the display:



- Release **MODE** and **ENTER**.

The following is now shown in the display:



- Selecting parameter 3.2:
  - Press and hold down **MODE**,
  - additionally quickly press and release  $\uparrow$  2x,
 The following is now shown in the display:



- Release **MODE**.

- Changing parameter settings:
  - Quickly press and release  $\uparrow$  to select CTCLOCKW.
- Switching to parameter 3.3 (Return to operating level) and saving the new settings:
  - Press and hold down **MODE**,
  - additionally quickly press and release  $\uparrow$  2x,
 The following is now shown in the display:



- Release **MODE**,
- Quickly press and release  $\uparrow$  to select **NV\_SAVE**,
- Press **ENTER** and hold down until the countdown goes from 3 to 0.

The new parameter setting is saved and the positioner automatically returns to the operating level. It continues in the operating mode that was active prior to the configuration level being called up.

## Setting the option modules

### Setting the mechanical position indication

- Loosen the screws for the housing cover and remove it.
- Rotate the position indicator on the shaft to the desired position.
- Attach the housing cover and screw it onto the housing. Tighten the screws so that they are hand-tight.
- Attach the symbol label to mark the minimum and maximum valve positions on the housing cover.

### Note

The labels are located on the inside of the housing cover.

## ... 8 Commissioning

### ... Sample parameters

#### Setting the mechanical limit switch with proximity switches

1. Loosen the screws for the housing cover and remove it.

#### CAUTION

##### Risk of injury!

The device includes slot sensors with sharp edges.

- Adjust the metal tags using a screwdriver only!

2. Set the upper and lower switching points for binary feedback as follows:
  - Select the 'Manual Adjustment' operating mode and move the final control element by hand into the lower switching position.
  - Using a screwdriver, adjust the metal tag of proximity switch 1 (lower contact) on the axis until contact is made, i. e., just before it is inserted in the proximity switch. The slot sensor enters proximity switch 1 when the feedback shaft is rotated clockwise (as viewed from the front).
  - Move the final control element by hand into the upper switching position.
  - Using a screwdriver, adjust the metal tag of proximity switch 2 (upper contact) on the axis until contact is made, i. e., just before it is inserted in the proximity switch. The slot sensor enters proximity switch 2 when the feedback shaft is rotated counter-clockwise (as viewed from the front).
3. Attach the housing cover and screw it onto the housing.
4. Tighten the screws so that they are hand-tight.

#### Setting the mechanical limit switch with 24 V microswitches

1. Loosen the screws for the housing cover and remove it.
2. Select the 'Manual Adjustment' operating mode and move the final control element by hand into the desired switching position for contact 1.
3. Set maximum contact (①, lower washer).  
Fasten the upper washer with the special adjustment retainer and rotate the lower washer manually.
4. Select the 'Manual Adjustment' operating mode and move the final control element by hand into the desired switching position for contact 2.
5. Set minimum contact (②, upper washer);  
Fasten the lower washer with the special adjustment retainer and rotate the upper washer manually.
6. Connect the microswitch.
7. Attach the housing cover and screw it on to the housing.
8. Tighten the screws so that they are hand-tight.



## 9 Operation

### Safety instructions

#### ⚠ CAUTION

##### Risk of injury due to incorrect parameter values!

Incorrect parameter values can cause the valve to move unexpectedly. This can lead to process failures and result in injuries.

- Before recommissioning a positioner that was previously in use at another location, always reset the device to its factory settings.
- Never start automatic adjustment before restoring the factory settings!

If there is a chance that safe operation is no longer possible, take the device out of operation and secure it against unintended startup.

### Parameterization of the device

The LCD display features operating buttons which enable the device to be operated with the housing cover open.

#### Menu navigation

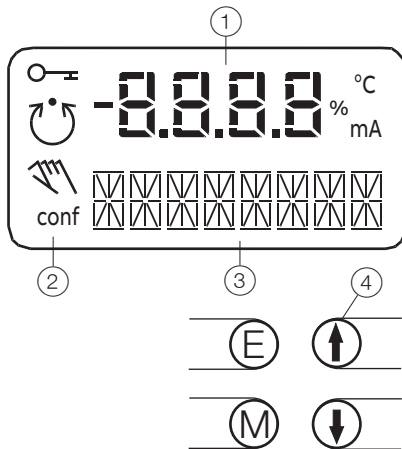

- |                           |   |
|---------------------------|---|
| ① Value display with unit | ③ Designator display                    |
| ② Symbol display          | ④ Operating buttons for menu navigation |

Figure 25: LCD display with operating buttons

#### Value display with unit

This 7-segment display with four digits indicates parameter values or parameter reference numbers. For values, the physical unit (°C, %, mA) is also displayed.

#### Designator display

This 14-segment display with eight digits indicates the designators of the parameters with their status, of the parameter groups, and of the operating modes.

#### Description of symbols

Symbol	Description
	Operation or access is restricted.
	Control loop is active. The symbol is displayed when the positioner is in operating mode 1.0 CTRL_ADP (adaptive control) or 1.1 CTRL_FIX (fixed control) at operating level. On the configuration level there are test functions for which the controller will be active as well. The control loop symbol will also be displayed when these functions are active.
	Manual adjustment. The symbol is displayed when the positioner is in operating mode 1.2 MANUAL (manual adjustment within the stroke range) or 1.3 MAN_SENS (manual adjustment within the measuring range) at operating level. At configuration level, manual adjustment is active when setting the valve range limits (parameter group 6 MIN_VR (min. of valve range) and 6 MAX_VR (max. of valve range)). The symbol will also be displayed when these parameters are being set.
conf	The configuration icon indicates that the positioner is at the configuration level. The control operation is inactive.



conf

The four operating buttons **ENTER**, **MODE**, **↑** and **↓** are pressed individually or in certain combinations according to the function desired.

## ... 9 Operation

### ... Parameterization of the device

#### Operating button functions

Control button	Meaning
ENTER	<ul style="list-style-type: none"> <li>Acknowledge message</li> <li>Start an action</li> <li>Save in the non-volatile memory</li> </ul>
MODE	<ul style="list-style-type: none"> <li>Choose operating mode (operating level)</li> <li>Select parameter group or parameter (configuration level)</li> </ul>
↑	UP direction button
↓	DOWN direction button
Press and hold all four buttons for 5 s	Reset

### Menu levels

The positioner has two operating levels.

#### Operating level

On the operating level the positioner operates in one of four possible operating modes (two for automatic control and two for manual mode). Parameters cannot be changed or saved on this level.

#### Configuration level

On this level most of the parameters of the positioner can be changed locally. The PC is required to change the limit values for the movement counter, the travel counter, and the user-defined characteristic curve.

On the configuration level the active operating mode is deactivated. The I/P module is in neutral position. The control operation is inactive.

### NOTICE

#### Property damage

During external configuration via a PC, the positioner no longer responds to the set point current. This may lead to process failures.

- Before any external parameterization, always move the actuator to the safety position and activate manual adjustment.

#### Note

For detailed information on how to parameterize device, consult the associated operating instructions and/or configuration and parameterization instructions.

## 10 Maintenance

The positioner does not require any maintenance if it is used as intended under normal operating conditions.

#### Note

Manipulation by users shall immediately render the warranty for the device invalid.

To ensure fault-free operation, it is essential that the device is supplied with instrument air that is free of oil, water, and dust.

## 11 Recycling and disposal

#### Note



Products that are marked with the adjacent symbol may **not** be disposed of as unsorted municipal waste (domestic waste).

They should be disposed of through separate collection of electric and electronic devices.

This product and its packaging are manufactured from materials that can be recycled by specialist recycling companies.

Bear the following points in mind when disposing of them:

- As of 8/15/2018, this product will be under the open scope of the WEEE Directive 2012/19/EU and relevant national laws (for example, ElektroG - Electrical Equipment Act - in Germany).
- The product must be supplied to a specialist recycling company. Do not use municipal waste collection points. These may be used for privately used products only in accordance with WEEE Directive 2012/19/EU.
- If there is no possibility to dispose of the old equipment properly, our Service can take care of its pick-up and disposal for a fee.

## 12 Additional documents

#### Note

All documentation, declarations of conformity and certificates are available in ABB's download area.

[www.abb.com/positioners](http://www.abb.com/positioners)

## 13 Appendix

### Return form

#### Statement on the contamination of devices and components

Repair and/or maintenance work will only be performed on devices and components if a statement form has been completed and submitted.

Otherwise, the device/component returned may be rejected. This statement form may only be completed and signed by authorized specialist personnel employed by the operator.

#### Customer details:

Company: \_\_\_\_\_

Address: \_\_\_\_\_

Contact person: \_\_\_\_\_

Telephone: \_\_\_\_\_

Fax: \_\_\_\_\_

Email: \_\_\_\_\_

#### Device details:

Type: \_\_\_\_\_

Serial no.: \_\_\_\_\_

Reason for the return/description of the defect: \_\_\_\_\_

#### Was this device used in conjunction with substances which pose a threat or risk to health?

Yes                       No

If yes, which type of contamination (please place an X next to the applicable items):

biological

corrosive / irritating

combustible (highly / extremely combustible)

toxic

explosive

other toxic substances

radioactive

Which substances have come into contact with the device?

1. \_\_\_\_\_

2. \_\_\_\_\_

3. \_\_\_\_\_

We hereby state that the devices/components shipped have been cleaned and are free from any dangerous or poisonous substances.

\_\_\_\_\_  
Town/city, date

\_\_\_\_\_  
Signature and company stamp



CONTROL DOCUMENT NO 901064

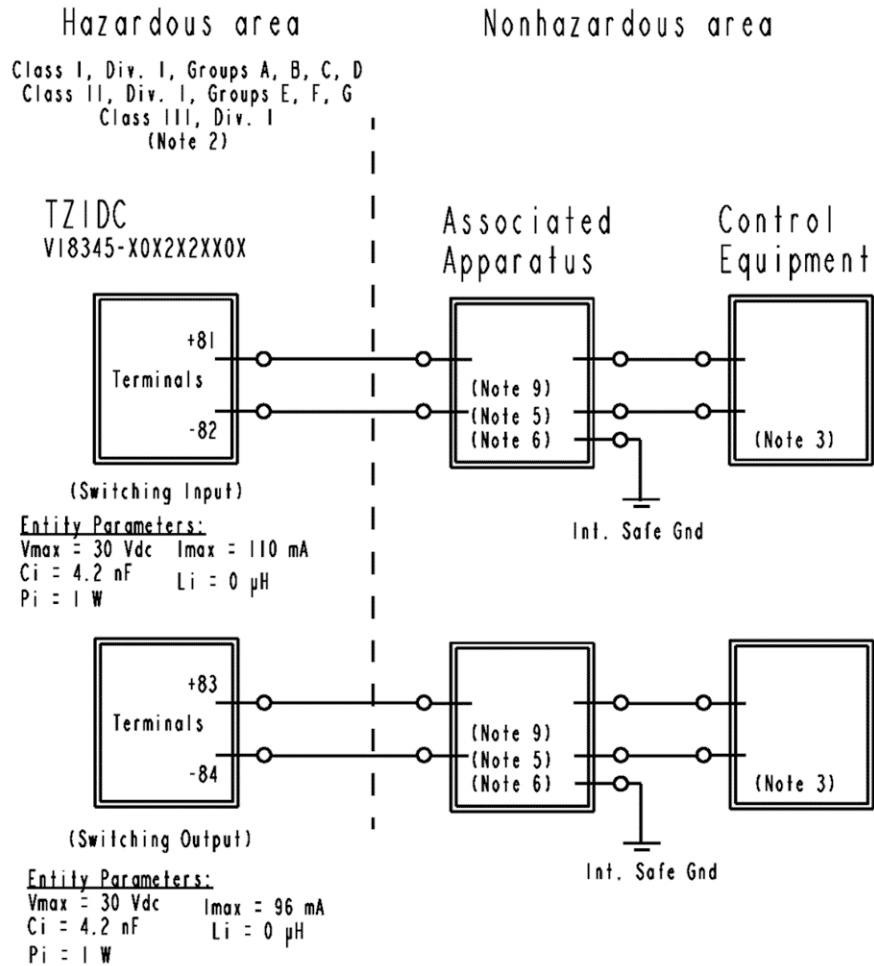

Copyright reserved  
 This drawing is the property of ABB.  
 Neither the drawing, nor reproductions of it  
 nor information derived from it is to be given to others.  
 No use is to be made by others without the written  
 permission of ABB.

				All Dimensions in mm		Title	Scale
				Date	Name	CONTROL DOCUMENT	
				Drawn 08-Apr-99	Lasorzik		
				Checked			
				 <b>ABB Automation</b>		Drawing No. (Part No)	Sheet
						901064	2 / 4
10	-	05.10.09	Lasorzik			Replacement for:	Category:
Rev.	Amendment	Date	Name			-	-



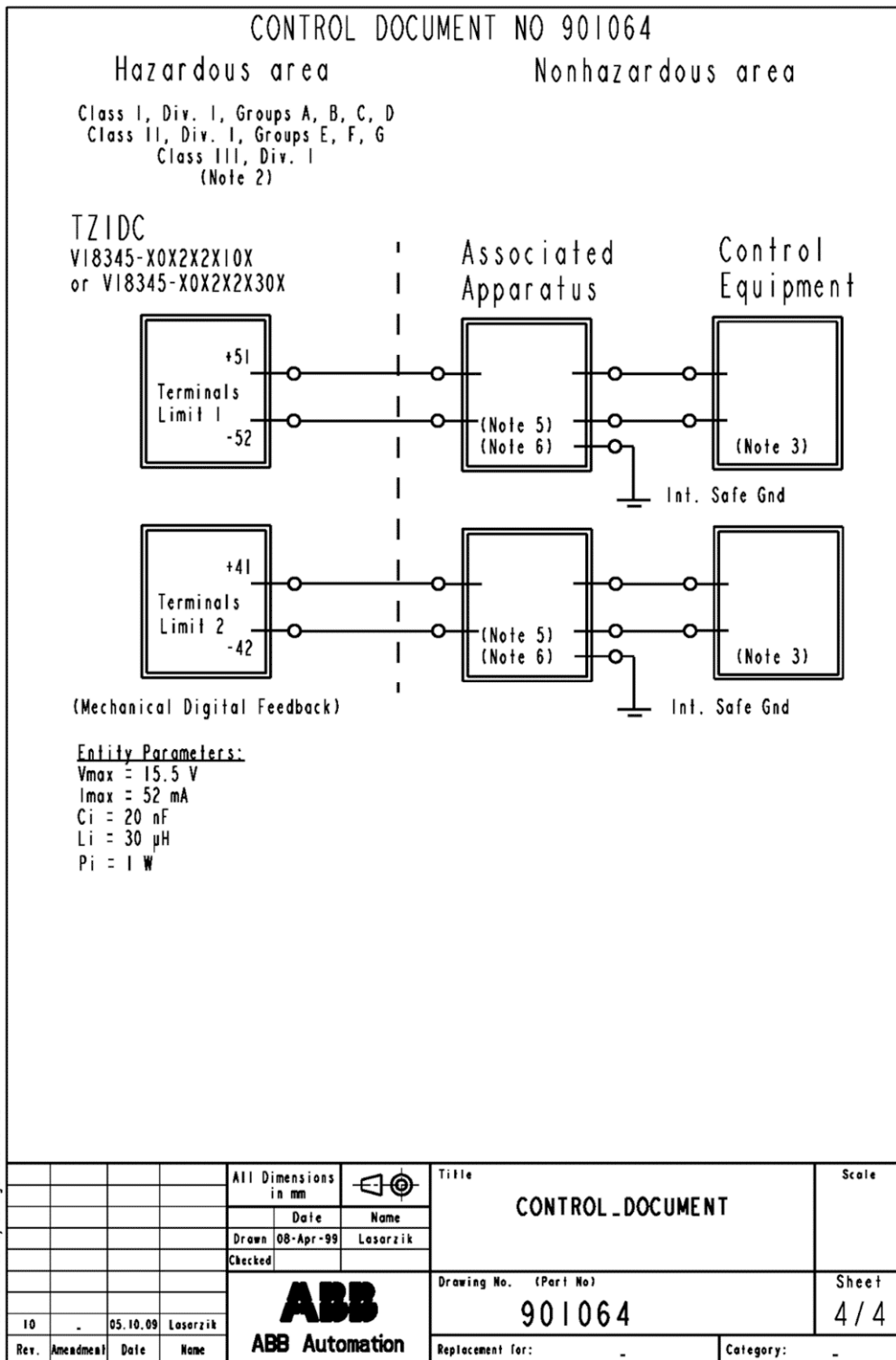

Copyright reserved  
 This drawing is the property of ABB.  
 Neither the drawing nor reproductions of it  
 nor information derived from it is to be given to others.  
 No use is to be made injurious to ABB.

# ... 13 Appendix

## FM installation drawing No. 901265

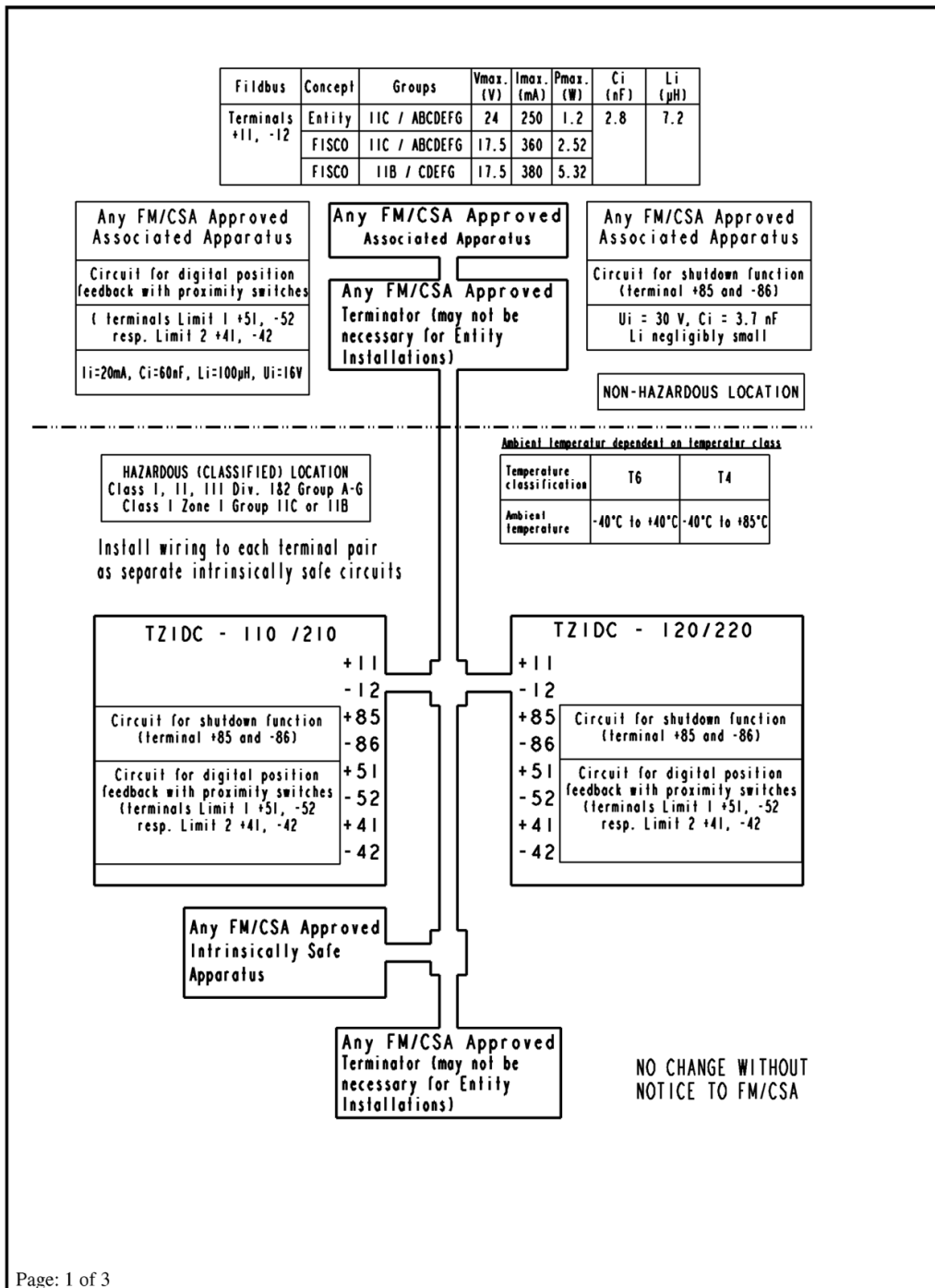

Page: 1 of 3

-	-	2003	Date	Name	Title	Scale
		Name	27.03.03	Thiem.	FM/CSA-Control-Document	/
		Appr.				
		Std.				
3	Rev.2	26.06.06	Thie.	<b>ABB</b> Automation Products	Drwg.-No. (Part-No.)	
2	Rev.1	22.05.06	Thie.		<b>901265</b>	
1	Rev.0	27.03.	Thie.			
Rev.	Chang	Date	Name		Supersedes Dwg. :	Part Class:



**FM/CSA-CONTROL-DOCUMENT\_901265**

**FISCO rules**

The FISCO Concept allows the interconnection of intrinsically safe apparatus to associated apparatus not specifically examined in such combination. The criterion for such interconnection is that the voltage ( $V_{max}$ ), the current ( $I_{max}$ ) and the power ( $P_i$ ) which intrinsically safe apparatus can receive and remain intrinsically safe, considering faults, must be equal or greater than the voltage ( $U_o, V_{oc}, V_t$ ), the current ( $I_o, I_{sc}, I_t$ ) and the power ( $P_o$ ) which can be provided by the associated apparatus (supply unit). In addition, the maximum unprotected residual capacitance ( $C_i$ ) and inductance( $L_i$ ) of each apparatus (other than the terminators) connected to the Fieldbus must be less than or equal to 5nF and 10  $\mu$ H respectively.

In each I.S. Fieldbus segment only one active source, normally the associated apparatus, is allowed to provide the necessary power for the Fieldbus system. The allowed voltage ( $U_o, V_{oc}, V_t$ ) of the associated apparatus used to supply the bus must be limited to the range of 14V d.c. to 24V d.c. All other equipment connected to the bus cable has to be passive, meaning that the apparatus is not allowed to provide energy to the system, except to a leakage current of 50  $\mu$ A for each connected device. Separately powered equipment needs a galvanic Isolation to insure that the intrinsically safe Fieldbus circuit remains passive.

The cable used to interconnect the devices needs to comply with the following parameters:

Loop resistance  $R'$ : 15...150  $\Omega$ /km

Inductance per unit length  $L'$ : 0.4...1mH/km

Capacitance per unit length  $C'$ :80...200 nF / km

$C' = C'$  line/line + 0.5 $C'$  line/screen, if both lines are floating

or

$C' = C'$  line/line +  $C'$  Line/screen, if the screen is connected to one line

Length of spur cable: max. 30m

Length of trunk cable: max. 1km

Length of splice: max. 1m

Terminators

At each end of the trunk cable an approved line terminator with the following parameters is suitable:

$R = 90...100 \Omega$

$C = 0...2.2 \mu$ F.

System evaluation

The number of passive devices like transmitters, actuators, connected to a single bus segment is not limited due to I.S. Reasons. Furthermore, if the above rules are respected, the inductance and capacitance of the cable need not to be considered and will not impair the intrinsic safety of the installation.

-	-			2003	Date	Name	Title	Scale
				Name	27.03.03	Thiem.	FM/CSA-Control-Document	/
				Appr.				
				Std.				
3	Rev.2	26.06.06	Thie.	<b>ABB</b> Automation Products			Drwg.-No. (Part-No.)	
2	Rev.1	22.05.06	Thie.				<b>901265</b>	
1	Rev.0	27.03.	Thie.					
Rev.	Chang	Date	Name				Supersedes Dwg. :	Part Class:



## Trademarks

HART is a registered trademark of FieldComm Group, Austin, Texas, USA

FOUNDATION Fieldbus is a registered trademark of FieldComm Group, Austin, Texas, USA.

PROFIBUS and PROFIBUS PA are registered trademarks of PROFIBUS & PROFINET International (PI)



---

**ABB Limited**

**Measurement & Analytics**

Howard Road, St. Neots  
Cambridgeshire, PE19 8EU  
UK

Tel: +44 (0)870 600 6122

Fax: +44 (0)1480 213 339

Email: [enquiries.mp.uk@gb.abb.com](mailto:enquiries.mp.uk@gb.abb.com)

**ABB Inc.**

**Measurement & Analytics**

125 E. County Line Road  
Warminster, PA 18974  
USA

Tel: +1 215 674 6000

Fax: +1 215 674 7183

**ABB Automation Products GmbH**

**Measurement & Analytics**

Schillerstr. 72  
32425 Minden  
Germany

Tel: +49 571 830-0

Fax: +49 571 830-1806

[abb.com/positioners](http://abb.com/positioners)

---

We reserve the right to make technical changes or modify the contents of this document without prior notice. With regard to purchase orders, the agreed particulars shall prevail. ABB does not accept any responsibility whatsoever for potential errors or possible lack of information in this document.

We reserve all rights in this document and in the subject matter and illustrations contained therein. Any reproduction, disclosure to third parties or utilization of its contents – in whole or in parts – is forbidden without prior written consent of ABB.

Copyright© 2018 ABB  
All rights reserved

3KXE341007R4401