

# CONDENSED CATALOG

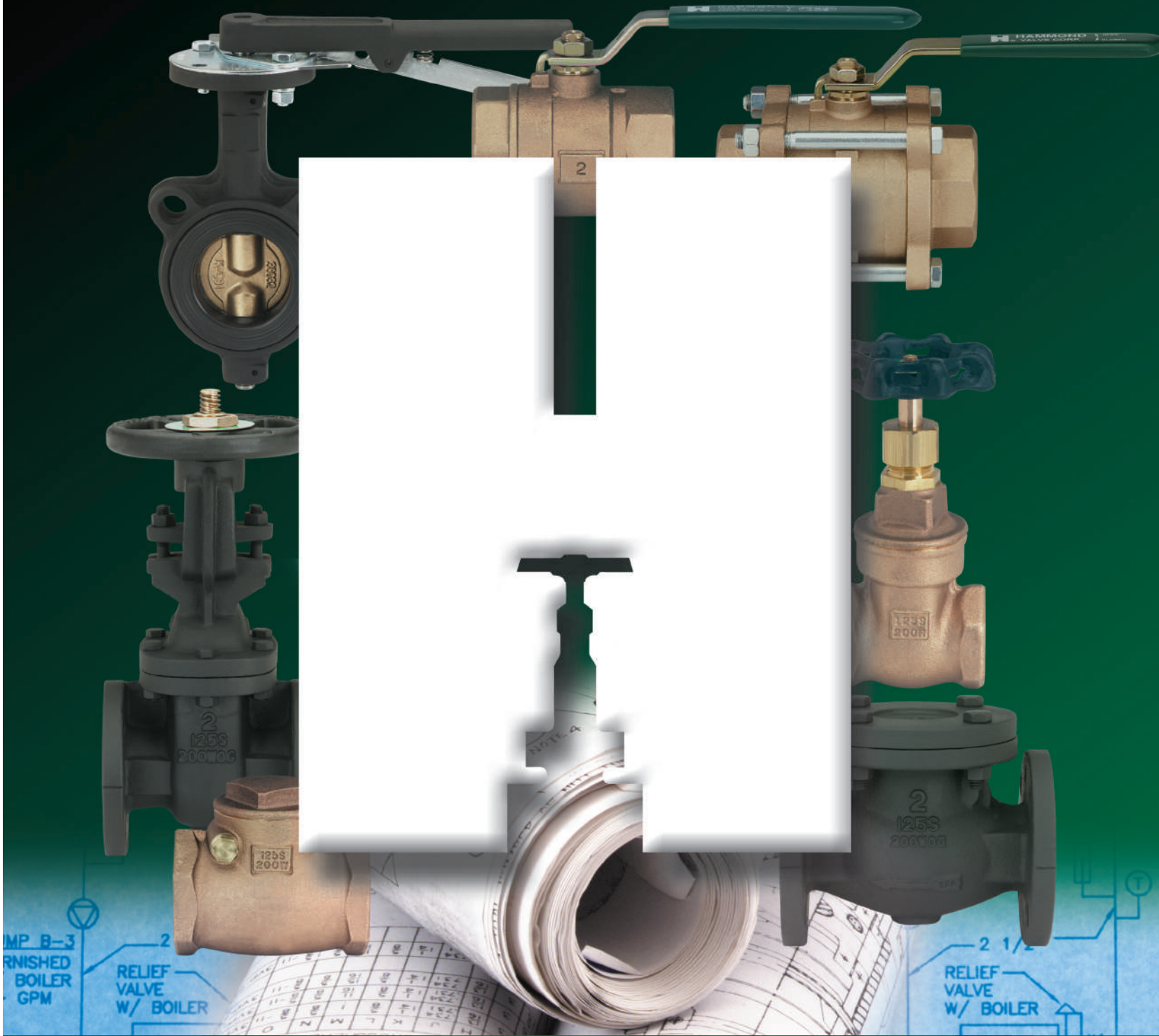

QUALITY YOU CAN BUILD ON

  
**HAMMOND**VALVE®  
BETTER AT EVERY TURN



# Pressed for time?

JUST PRESS, CRIMP AND TRIPLE YOUR PRODUCTIVITY!<sup>1</sup>

Reduce installation time up to 68% with Hammonds's extensive new line of UltraPress<sup>®</sup> press-connection valves. Perfect for potable water, HVAC and inert gas systems, UltraPress valves quickly install without brazing, soldering or special tools. With no open flame required, water service connections can be made wet or dry for faster, easier repairs. Plus, UltraPress eliminates heat-installation costs like solder, flux, propane torches, oxygen/gas bottles and "hot" work permits.

Available in fully annealed brass, bronze and lead-free<sup>2</sup> UltraPure<sup>®</sup> alloys—in ball, gate, globe and check styles—you're sure to find the valves you need. Accessories, too, like extension, INSULATOR/MS<sup>®</sup> and lockout handles.

See the full line of UltraPress products, additional features, full specifications, and a downloadable brochure at [www.UltraPressValves.com](http://www.UltraPressValves.com).

<sup>1</sup> Estimate based on MCAA's WebLEM (Web-based Labor Estimating Manual).  
<sup>2</sup> Lead content less than 0.25%, defined as lead-free by US Senate Bill S.3874.  
 © 2016, Milwaukee Valve Company.



16550 West Stratton Drive • New Berlin, WI 53151  
 262.432.2700 • Fax 262.432.2701  
[www.HammondValve.com](http://www.HammondValve.com) • [www.UltraPressValves.com](http://www.UltraPressValves.com)



# CONTENTS

**BALL VALVES** ..... **PAGE 4-7**

**BUTTERFLY VALVES** ..... **PAGE 8-9**

- 5000 Series Commercial Construction
- 6000 Series Standard Industrial
- UltraPure® Commercial Construction
- 6100/6200-HP Series High-Pressure
- HP Series High-Performance
- Grooved

**ACTUATION** ..... **PAGE 10**

**BRONZE VALVES** ..... **PAGE 11-15**

- Gate, Page 11-12
- Globe & Angle, Page 13
- Check, Page 14-15

**FIRE PROTECTION VALVES** ..... **PAGE 15**

**CAST STEEL VALVES** ..... **PAGE 16**

- Gate
- Globe
- Check

**IRON VALVES** ..... **PAGE 17**

- Gate & Clip-Gate
- Globe
- Check Valves

**PLUMBING VALVES** ..... **PAGE 18-21**

**ULTRAPURE® LEAD-FREE VALVES FOR POTABLE WATER SERVICE** . . **PAGE 22-25**

**ENGINEERING & DESIGN CAPABILITIES** ..... **PAGE 26**

Rev. 04/22

The information presented on this sheet is correct at time of publication. Hammond Valve reserves the right to change design and/or materials without notice. For our Installation, Operation and Maintenance Manual and the most current product information go to [www.hammondvalve.com](http://www.hammondvalve.com). Hammond Valve is a registered trademark of Milwaukee Valve. ⚠ State of California Prop 65 WARNING: Cancer and Reproductive Harm. For more information visit [www.p65warnings.ca.gov](http://www.p65warnings.ca.gov).

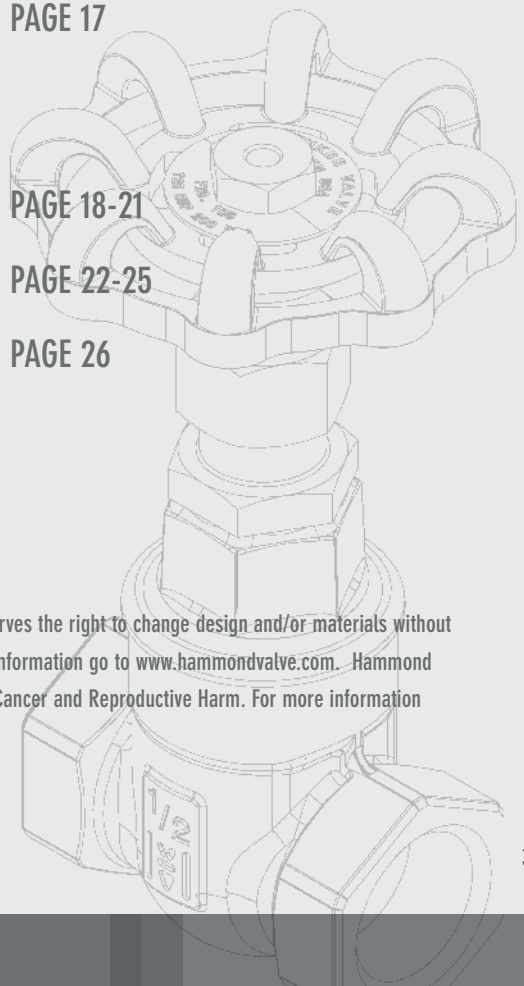
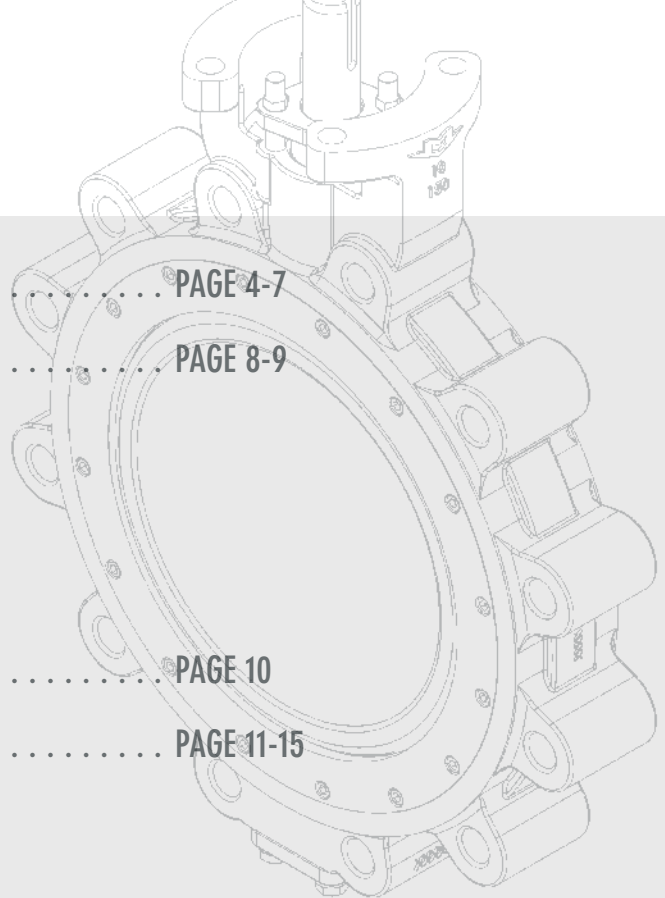

# BALL VALVES



8501-16



8501 P2



8501H

## 2-PIECE BRONZE

### Standard Port

#### 8501 / 8503

600 WOG 150 SWP, MSS SP-110, Threaded, 8503 with Stainless Steel Ball and Stem 1/4" thru 3"

#### 8501E

125 psig, MSS SP-110, Latch Lock Handle, Threaded with Exhaust Port 1/4" thru 2"

#### 8501M

600 WOG 150 SWP, MSS SP-110, Male x Female 1/4" thru 2"

#### 8501 P2 / 8503 P2

200 psig @ 250°F, MSS SP-110, Press X Press, 8503 P2 with Stainless Steel Ball and Stem 1/2" thru 3"

#### 8511 / 8513

600 WOG, MSS SP-110, Solder, 8513 with Stainless Steel Ball & Stem 3/8" thru 3"

### Full Port

#### 8501H

600 WOG, MSS SP-110, Threaded With Hose, Cap and Chain 1/2" and 3/4"

#### 8511H

600 WOG, MSS SP-110, Solder With Hose, Cap and Chain 1/2" and 3/4"

#### 8501H P1 / 8503H P1

200 psig @ 250°F, MSS SP-110, Press X Hose, 8503H P1 with Stainless Steel Ball & Stem 1/2" and 3/4"

#### Options/Accessories

8501/8503

8511/8513

Insulator Handle with Memory Stop (16)

Oval Handle (04)

Stainless Steel Handle (08)

Extension Handle with Memory Stop (09)

Extension Handle (06)

Memory Stop (02)

Tee Handle (03)

Chain Lever (12)

Locking Handle (07)



8301A



UP8501 P2-06



UP8501 P2-16

#### Options/Accessories

8301A/8303A / 8311A/8313A

UP8501/UP8503 / UP8511/UP8513

Insulator Handle with Memory Stop (16)

Oval Handle (04)

Stainless Steel Handle (08)

Extension Handle with Memory Stop (09)

Extension Handle (06)

Memory Stop (02)

Tee Handle (03)

Chain Lever (12)

Locking Handle (07)

continued

## 2-PIECE BRONZE

### Full Port

#### 8301A / 8303A

600 WOG 150 SWP, MSS SP-110, Threaded, 8303A with Stainless Steel Ball & Stem 1/4" thru 2"

#### 8301A P2 / 8303A P2

200 psig @ 250°F, MSS SP-110, Press X Press, 8303A with Stainless Steel Ball & Stem 1/2" thru 2"

#### 8311A / 8313A

600 WOG, 150 SWP, MSS SP-110, Solder, 8313A with Stainless Steel Ball & Stem 3/8" thru 2"

## 2-PIECE BRONZE LEAD-FREE BRONZE BALL VALVES FOR POTABLE WATER SERVICE



### Standard Port

#### UP8501 / UP8503 \*

600 WOG, MSS SP-110, Threaded, UP8503 with Stainless Steel Ball & Stem 1/4" thru 3"

#### UP8501 P2 / UP8503 P2 \*

200 psig @ 250°F, MSS SP-110, Press X Press, UP8503 with Stainless Steel Ball and Stem 1/2" thru 3"

#### UP8511 / UP8513 \*

600 WOG, MSS SP-110, Solder, UP8513 with Stainless Steel Ball & Stem 3/8" thru 3"



UP8501H



UP8301A P2-16



UP8311A

**Options/Accessories**

- UP8501/UP8511
- UP8301A/UP8303A
- UP8311A/UP8313A
- Insulator Handle with Memory Stop (16)
- Oval Handle (04)
- Stainless Steel Handle (08)
- Extension Handle with Memory Stop (09)
- Extension Handle (06)
- Memory Stop (02)
- Tee Handle (03)
- Chain Lever (12)
- Locking Handle (07)

continued  
**2-PIECE**   
**BRONZE LEAD-FREE**  
**BRONZE BALL**  
**VALVES FOR POTABLE**  
**WATER SERVICE**

**Full Port**

**UP8501H \***  
 600 WOG, MSS SP-110, Threaded  
 With Hose, Cap and Chain  
 1/2" and 3/4"

**UP8511H \***  
 600 WOG, Solder with Hose,  
 Cap and Chain  
 1/2" and 3/4"

**UP8301A / UP8303A \***  
 600 WOG, MSS SP-110, Threaded,  
 UP8303A with Stainless Steel  
 Ball & Stem  
 1/4" thru 2"

**UP8501H P1 \***  
 200 psig @ 250°F, MSS SP-110,  
 Press X Hose  
 1/2" and 3/4"

**UP8301A P2 / UP8303A P2 \***  
 200 psig @ 250°F, MSS SP-110,  
 Press X Press, UP8303A with  
 Stainless Steel Ball and Stem  
 1/2" thru 2"

**UP8311A / UP8313A \***  
 600 WOG, MSS SP-110, Solder,  
 UP8313A with Stainless Steel  
 Ball & Stem  
 3/8" thru 2"



8201



8901



BA-480S

**Options/Accessories**

- 8201/8211
- Oval Handle (04)
- Stainless Steel Handle (08)
- Memory Stop (02)
- Tee Handle (03)
- Locking Handle (07)
- Extension Handle (06)
- 8901/8911 / BA-480B/BA-490B**
- Insulator Handle with Memory Stop (16)
- Oval Handle (04)
- Stainless Steel Handle (08)
- Extension Handle (06)
- Memory Stop (02)
- Tee Handle (03)
- Locking Handle (07)

**2-PIECE**  
**FORGED BRASS**

**Standard Port**

**8201**  
 400 WOG, Threaded  
 1/4" thru 4"

**8211**  
 400 WOG, Solder  
 3/8" thru 3"

**Full Port**

**8901**  
 600 WOG (1/4" thru 3"), 400  
 WOG (4"), CSA/UL/FM/CGA  
 Approved to 2", Threaded  
 1/4" thru 4"

**8911**  
 600 WOG (1/2" thru 3"), 400  
 WOG (4"), Heavy Pattern, Solder  
 1/2" thru 4"

**BA-480B / BA-480S\*\***  
 200 psig @ 250°F, Press X  
 Press, BA-480S with  
 Stainless Steel Ball & Stem  
 1/2" thru 3"

**BA-490B / BA-490S\*\***  
 200 psig @ 250°F, Press X  
 Threaded, BA-490S with  
 Stainless Steel Ball & Stem  
 1/2" thru 2"

**BA-480BH / BA-480SH\*\***  
 200 psig @ 250°F, Press X Hose,  
 BA-480SH with Stainless Steel  
 Ball & Stem,  
 1/2" thru 3/4"

**BA-481B\*\***  
 200 psig @ 250°F, Press X  
 Press, Extension Stem with  
 Memory stop,  
 1/2" thru 3"

**BA-491B\*\***  
 200 psig @ 250°F, Press X  
 Threaded, Extension stem with  
 Memory Stop,  
 1/2" thru 2"

\* Meets Senate law S3874. IAPMO tested and certified to NSF/ANSI 372 for "lead-free" compliance.

\*\*Tested and Certified by IAPMO R & T to NSF/ANSI 61 and NSF/ANSI 372 for Lead Free Compliance.

# BALL VALVES



UP8901



UPBA-480



UPBA-481B

#### Options/Accessories

UP8901/UP8911

UPBA-480B/UPBA-490B

Insulator Handle with Memory Stop (16)

Oval Handle (04)

Stainless Steel Handle (08)

Extension Handle (06)

Memory Stop (02)

Tee Handle (03)

Locking Handle (07)

## 2-PIECE LEAD-FREE FORGED BRASS BALL VALVES FOR POTABLE WATER SERVICE

Full Port

### UP8901 \*

600 WOG (1/4" thru 2") 400 WOG (2-1/2" thru 3") MSS SP-110, UL/CSA Rated to 2", Threaded 1/4" thru 3"

### UP8911 \*

600 WOG (1/2" thru 2") 400 WOG (2-1/2" thru 3"), MSS SP-110, Solder 1/2" thru 3"

### UPBA-480B / UPBA-480S \*

200 psig @ 250°F, MSS SP-110, Press X Press, UPBA-480S with Stainless Steel Ball and Stem 1/2" thru 4"

### UPBA-480BH / UPBA-480SH \*

200 psig @ 250°F, Press X Hose, BA-480SH with Stainless Steel Ball & Stem, 1/2" and 3/4"

### UPBA-481B / UPBA-481S \*

200 psig @ 250°F, MSS SP-110, Press X Press, Extension Stem With Memory Stop, UPBA-481S with Stainless Steel Ball and Stem 1/2" thru 3"

### UPBA-490B / UPBA-490S \*

200 psig @ 250°F, MSS SP-110, Press X Threaded, UPBA-490S with Stainless Steel Ball and Stem 1/2" thru 2"

### UPBA-491B / UPBA-491S \*

200 psig @ 250°F, MSS SP-110, Press X Threaded, Extension Stem With Memory Stop, UPBA-491S with Stainless Steel Ball and Stem 1/2" thru 2"



8111

## 2-PIECE BRASS CIRCULATOR-FLANGE

8100

600 WOG, Full Port, Sold in Pkg. of 2, Threaded 3/4" thru 1-1/4"

8111

600 WOG, Full Port, Sold in Pkg. of 2, Solder 3/4" thru 1-1/4"



8604-16



8614-TE



UP8614

**Options/Accessories**

8604/8603 / 8614/8613

UP8604/UP8603 / UP8614/UP8613

Insulator Handle with Memory Stop (16)

Oval Handle (04)

Stainless Steel Handle (08)

Extension Handle with Memory Stop (09)

Extension Handle (06)

Memory Stop (02)

Tee Handle (03)

Chain Lever (12)

Locking Handle (07)

## 3-PIECE BRONZE BALL VALVES

Full Port

**8604 / 8603**

600 WOG, 150 SWP, MSS SP-110, Threaded, 8603 with Stainless Steel Ball & Stem 1/4" thru 3" \*

**8614 / 8613**

600 WOG, 150 SWP, MSS SP-110, Solder, 8613 with Stainless Steel Ball and Stem 3/8" thru 3"

**8604 P2 / 8603 P2**

200 psig @ 250°F, MSS SP-110, Press X Press, 8603 P2 with Stainless Steel Ball and Stem 1/2" thru 2"

**8614TE / 8613TE**

600 WOG, 150 SWP, Solder, 8613TE with Stainless Steel Ball and Stem, Tube End 1/2" thru 2"

## 3-PIECE LEAD-FREE BRONZE BALL VALVES FOR POTABLE WATER

Full Port

**UP8604 / UP8603 \***

600 WOG, MSS SP-110, Threaded, UP8603 with Stainless Steel Ball & Stem 1/4" thru 3"

**UP8614 / UP8613 \***

600 WOG, MSS SP-110, Solder, UP8613 with Stainless Steel Ball & Stem 3/8" thru 3"

**UP8604 P2 / UP8603 P2 \***

200 psig @ 250°F, MSS SP-110, Press X Press, UP8603 P2 with Stainless Steel Ball & Stem 1/2" thru 2"



BA-260

## 2-PIECE, STAINLESS

Full Port

**BA-260**

1000 WOG, Stainless Steel Body and Ball, RPTFE Seats, Locking Handle, Threaded 1/4" thru 3"



\* Meets Senate law S3874. IAPMO tested and certified to NSF/ANSI 372 for "lead-free" compliance.

# BUTTERFLY VALVES



5211-03



5111-03



UPGG-245E



GG-SCS2

## 5000 SERIES — COMMERCIAL BUTTERFLY GROOVED SERIES

Concentric valve to MSS SP-67, Available in lug or wafer body. 5000 Series IAPMO tested and certified against NSF/ANSI 372 for lead-free\* compliance.

Body: Cast Iron ASTM A126 Class B

Disc: AlBr (Aluminum Bronze)

Stem: 416 Stainless Steel

Liner: EPDM

2" thru 12" rated at 200 WOG

14" thru 48" rated at 150 WOG

These valves are based on our 6000 Series, but intended for commercial applications in HVAC and similar systems. The valves feature a phenolic-backed rubber seat with optimized disc and stem design for reliable sealing, low torque, and long life. Lug butterfly valves 2" thru 12" are bi-directional dead-end service to 200 psig max. Valves 14" thru 24" are rated for uni-directional dead-end service to 150 psig. The valves are available with 10-position locking-lever handles (up to 12 inch) and gear operators.

### UPGG-245E

Polyamide Coated Ductile Iron Grooved End Butterfly, 300 psi, designed to MS SP-67 Extended Neck, Elastomer Encapsulated Disc 2" thru 10"

### GG-SCS2

Nylon Coated Ductile Iron Grooved End Butterfly, 300 psi, UL/FM, Extended Neck, Elastomer Encapsulated Disc 2 1/2" thru 10"



6111-03



6211-03



6211-02

## 6000 SERIES — INDUSTRIAL BUTTERFLY\*

Concentric valve to MSS SP-67, Available in lug or wafer body. Disc: Ni-plated Ductile Iron, AlBr, or Stainless Steel, nylon and epoxy-coated optional.

Stem: 416 or 316 Stainless Steel.

Liner: EPDM, Buna, FDA Neoprene, PTFE, Hypalon, Viton and many other options.

Body: Cast iron ASTM A126 Class B or Ductile Iron ASTM A536 65-45-12

2" thru 12" rated at 200 WOG

14" thru 48" rated at 150 WOG

These valves feature a phenolic-backed rubber seat with optimized disc and stem design for reliable sealing, low torque, and long life.

Lug butterfly valves 2" thru 12" are bi-directional dead-end

service to 200 psig max. BUNA and EPDM only. All others 150

psig uni-directional field

repairable. Valves 14" thru 24"

rated for uni-directional

dead-end service to 150 psig.

The valves are available with

on-board actuation direct from

the factory, 10 position locking

lever handles (up to 12 inch),

gear operators, or other

options — consult the factory.

- Available in Low Lead  
6411-00/6411-01/6411-03  
2" thru 12"

- 6411-00/6411-03  
14" thru 24"

Options/Accessories  
Rubber-Lined Butterfly  
Electric Actuation  
Pneumatic Actuation





6411-00/6411-01/6411-03  
(PICTURED WITH BARE STEM)



5111-03



HPILCS WITH LEVER HANDLE

**Options/Accessories**  
 Rubber-Lined Butterfly  
 High Performance Butterfly  
 Electric Actuation  
 Pneumatic Actuation

## LEAD-FREE COMMERCIAL BUTTERFLY

**6411-00/6411-01/6411-03 \***  
 Ductile Iron Body, Lug Style, Aluminum Bronze Disc, EPDM Liner, Bi-Directional Dead-End Service 200 psig Max, IAPMO Tested and certified against NSF/ANSI 372 for "Lead-free" compliance.  
 2" thru 12"

**6411-00/6411-03 \***  
 Ductile Iron Body, Lug Style, Aluminum Bronze Disc, EPDM Liner, Bi-Directional Dead-End Service 200 psig Max 2" thru 12", Uni-Directional Dead-End Service 150 psig Max, 14" thru 24", IAPMO Tested and certified against NSF/ANSI 372 for "Lead-free" compliance.

**5000 Series \***  
 Cast Iron Body, Lug Style, Aluminum Bronze Disc, EPDM Liner, Bi-Directional Dead-End Service 200 psig Max 2" thru 12", Uni-Directional Dead-End Service 150 psig Max, 14" thru 24", IAPMO Tested and certified against NSF/ANSI 372 for "Lead-free" compliance.

## HP SERIES HIGH PERFORMANCE BUTTERFLY

Double offset valve designed to MSS SP-68, ASME B16.34, and API 609, Category B. Available in lug or wafer body, ANSI Class 150 and 300 in sizes 2-1/2" thru 36"  
 Body: A216 WCB carbon steel or ASTM A351 CF8M  
 Stainless Steel



HPILCS WITH GEAR OPERATOR



HPILSS WITH GEAR OPERATOR

**Options/Accessories**  
 Rubber-Lined Butterfly  
 High Performance Butterfly  
 Electric Actuation  
 Pneumatic Actuation

## continued HP SERIES HIGH PERFORMANCE BUTTERFLY

Disc: ASTM A351 CF8M  
 Stainless Steel  
 Stem: 17-4PH or 316  
 Stainless Steel  
 Seats: RTFE standard, Virgin PTFE, UHMWPE and other options. These valves feature a double offset seat and disc design for superior sealing with no leakage and minimal seat contact and wear. The valves are available with on-board actuation direct from the factory, 10 position locking lever handles (up to 8 inch), gear operators on all valves, for other actuation options or accessories, consult the factory.

**HP1LSS4212/HP3LSS4212/  
 HP1LSS4213/HP3LSS4213**  
 Stainless Steel Body, Lug Style, Stainless Steel Disc, RPTE Seat, bi-directional dead-end service and double offset design. ANSI Class 150 and 300 available in sizes 2 1/2" - 24". Certified by IAPMO R&T to NSF/ANSI 61 and NSF/ANSI 372 for low lead requirements.

\* Meets Senate law S3874. IAPMO tested and certified to NSF/ANSI 372 for "lead-free" compliance.



6000 SERIES BUTTERFLY VALVE WITH PNEUMATIC ACTUATOR



HP SERIES LUG BUTTERFLY VALVE WITH PNEUMATIC ACTUATOR

## PNEUMATIC ACTUATION

### Actuation Options

Double-Acting Actuators  
Spring-Return Actuators  
Solenoid Valves  
Actuator Brackets  
Limit Switches  
Valve Positioners

### BA-260 2-Piece Stainless Steel Ball Valves

Available on 1/4" thru 3" Valves.

### Butterfly Valves

Available on HP Series High-Performance Butterfly Available in Wafer and Lugged Patterns. Available on 2" thru 48" Valves. Available on Class 150 2-6" thru 36". Available on Class 300 2-1/2" thru 36". Available on 5000 and 6000 Series Butterfly Valves. Available on Wafer and Lugged Patterns. Available on 2" thru 48".



BA-260 BALL VALVE WITH ELECTRIC ACTUATOR



6000 SERIES BUTTERFLY VALVE WITH ELECTRIC ACTUATOR



HP SERIES LUG BUTTERFLY VALVE WITH ELECTRIC ACTUATOR

## ELECTRIC ACTUATION

### Actuation Options

120 Volt AC and DC Voltages  
NEMA 4 and 7 Housings  
4-20 maDC Valve Positioners  
Actuator Brackets  
Extra Limit Switches  
Reversing Actuators

### BA-260 2-Piece Stainless Steel Ball Valves

Available on 1/4" thru 3" Valves.

### Butterfly Valves

Available on HP Series High-Performance Butterfly Valves. Available in Wafer and Lugged Patterns. Available on 2" thru 48" valves. Available on Class 150 2-1/2" thru 36". Available on Class 300 2-1/2" thru 36". Available on 5000 and 6000 Series Iron Butterfly Valves. Available on Wafer and Lugged Patterns. Available on 2" to 48" valves.



IB645

## BRONZE GATE VALVES, NON-RISING STEM

Threaded End

**IB645**  
125 SWP-200 WOG, MSS SP-80,  
Threaded Bonnet  
1/4" thru 4"



IB647

**IB646**  
150 SWP-300 WOG, MSS SP-80,  
Threaded Bonnet  
1/4" thru 4"

**IB638**  
150 SWP-300 WOG, MSS SP-80,  
Union Bonnet  
1/4" thru 2"

**IB656**  
300 SWP-1000 WOG,  
Stainless-Steel Seats,  
MSS SP-80, Union Bonnet  
1/4" thru 2"



IB656

**UP645 \***  
UltraPure® Lead Free Bronze,  
Threaded, 300 WOG, MSS SP-80,  
Threaded Bonnet  
1/4" thru 2"

**UP667 \***  
UltraPure® Lead Free Brass,  
Threaded, 200 WOG, Threaded  
Bonnet  
1/4" thru 2"



UP667

Solder End

**IB647**  
125 SWP-200 WOG, MSS SP-80,  
Threaded Bonnet  
3/8" thru 4"

**UP647 \***  
UltraPure® Lead-Free Bronze, 300  
WOG, MSS SP-80, Threaded Bonnet  
3/8" thru 2"

**UP668 \***  
UltraPure® Lead-Free Brass, Solder,  
200 WOG, Threaded Bonnet  
1/4" thru 2"



UP647

## continued BRONZE GATE VALVES, NON-RISING STEM

Press x  
Press Ends 

**IB645 P2**  
200 psig @ 250°F, MSS SP-80,  
Threaded Bonnet  
1/2" thru 2"

**IB638 P2**  
200 psig @ 250°F, MSS SP-80,  
Union Bonnet  
1/2" thru 2"

**UP645 P2 \***  
UltraPure® Lead-Free Bronze,  
200 psig @ 250°F, MSS SP-80,  
Threaded Bonnet  
1/2" thru 2"



IB638 P2

## BRONZE GATE VALVES, RISING STEM

Threaded End

**IB640**  
125 SWP-200 WOG, MSS SP-80,  
Threaded Bonnet  
1/4" thru 4"

**IB641**  
150 SWP-300 WOG, MSS SP-80,  
Threaded Bonnet  
1/4" thru 4"



UP645 P2

Press x  
Press Ends 

**IB640 P2**  
125 SWP-200 psig @ 250°F,  
MSS SP-80, Threaded Bonnet  
1/2" thru 2"



IB640

\* Meets Senate law S3874. IAPMO tested and certified to NSF/ANSI 372 for "lead-free" compliance.

# BRONZE VALVES



UP640



IB651



IB635

## continued BRONZE GATE VALVES, RISING STEM

Threaded End

### UP640 \*

UltraPure® Lead-Free Bronze,  
300 WOG, MSS SP-80,  
Threaded Bonnet  
1/4" thru 2"

### IB617

125 SWP-200 WOG,  
MSS SP-80, Union Bonnet  
1/4" thru 3"

### IB629

150 SWP-300 WOG, MSS SP-80,  
Union Bonnet  
1/4" thru 3"

### IB650

200 SWP-400 WOG, Cu-Ni Seat  
Ring, MSS SP-80, Union Bonnet  
1/4" thru 2"

### IB651

200 SWP-400 WOG, Stainless-  
Steel Seat Ring, MSS SP-80,  
Union Bonnet  
1/4" thru 3"

### IB652

300 SWP-1000 WOG, Cu-Ni Seat  
Ring, MSS SP-80, Union Bonnet  
1/4" thru 2"

### IB654

300 SWP-1000 WOG,  
Stainless-Steel Seat Ring,  
MSS SP-80, Union Bonnet  
1/4" thru 3"

Solder End

### IB635

125 SWP-200 WOG, MSS SP-80,  
Threaded Bonnet  
3/8" thru 4"



IB648



UP635



UP640 P2

## continued BRONZE GATE VALVES, RISING STEM

Solder End

### IB648

150 SWP-300 WOG,  
MSS SP-80, Union Bonnet  
3/8" thru 3"

### UP635 \*

UltraPure® Lead-Free Bronze,  
300 WOG, MSS SP-80,  
Threaded Bonnet  
3/8" thru 2"

Press x  
Press Ends



### IB640 P2

200 psig @ 250°F,  
MSS SP-80, Threaded Bonnet  
1/2" thru 2"

### IB617 P2

200 psig @ 250°F,  
MSS SP-80, Union Bonnet  
1/2" thru 2"

### UP640 P2 \*

UltraPure® Lead-Free Bronze,  
200 psig @ 250°F, MSS SP-80,  
Threaded Bonnet  
1/2" thru 2"



IB440

## BRONZE GLOBE VALVES

### Threaded Ends

#### IB440

125 SWP-200 WOG, MSS SP-80, Bronze Disc, Threaded Bonnet 1/8" thru 3"

#### IB415

200 SWP-400 WOG, MSS SP-80, Needle Disc, Threaded Bonnet 1/8" thru 3/4"

#### IB413T

150 SWP-300 WOG, MSS SP-80, PTFE Disc, Union Bonnet 1/8" thru 3"

#### IB412

300 SWP-1000 WOG, MSS SP-80, Bronze Disc, Union Bonnet 1/4" thru 2"

#### IB434

200 SWP-400 WOG, MSS SP-80, SS Seat & Disc, Union Bonnet 1/4" thru 2"

#### IB444

300 SWP-1000 WOG, MSS SP-80, SS Seat & Disc, Union Bonnet 1/4" thru 2"

#### UP440 \*

UltraPure® Lead-Free Bronze, 300 WOG, MSS SP-80, Bronze Disc, Threaded Bonnet 1/8" thru 2"

### Solder Ends

#### IB418

125 SWP-200 WOG, MSS SP-80, Bronze Disc, Threaded Bonnet 3/8" thru 2"

#### IB423

150 SWP-300 WOG, MSS SP-80, PTFE Disc, Union Bonnet 1/2" thru 3"



IB423



UP418



440 P2



IB463



IB454T

continued

## BRONZE GLOBE VALVES

### Solder Ends

#### UP418 \*

UltraPure® Lead-Free Bronze, 300 WOG, MSS SP-80, Bronze Disc, Threaded Bonnet 3/8" thru 2"

Press x  
Press Ends



#### IB440 P2

200 psig @ 250°F, MSS SP-80, Bronze Disc, Threaded Bonnet 1/2" thru 2"

#### IB413T P2

200 psig @ 250°F, MSS SP-80, PTFE Disc, Union Bonnet 1/2" thru 2"

#### UP502 P2 \*

UltraPure® Lead-Free Bronze, 200 psig @ 250°F, MSS SP-80, Bronze Disc, Threaded Bonnet 1/2" thru 2"

## BRONZE ANGLE VALVES

### Threaded Ends

#### IB463

125 SWP-200 WOG, MSS SP-80, Bronze Disc, Threaded Bonnet 1/4" thru 2-1/2"

#### IB454T

150 SWP-300 WOG, MSS SP-80, PTFE Disc, Union Bonnet 1/4" thru 2"



IB413T P2

IB444

\* Meets Senate law S3874. IAPMO tested and certified to NSF/ANSI 372 for "lead-free" compliance.

# BRONZE VALVES



IB940



UP967

## BRONZE CHECK VALVES HORIZONTAL SWING CHECK

Threaded Ends

### IB904

Bronze, 125 SWP-200 WOG, MSS SP-80, Brass Disc (1/4" - 1-1/2"), Bronze Disc (2" - 3")

1/4" thru 3"

### IB940

Bronze, 125 SWP-200 WOG, MSS SP-80, PTFE Disc  
1/4" thru 2"

### IB946

Bronze, 150 SWP-300 WOG, MSS SP-80, PTFE Disc  
1/4" thru 2"

### UP904 \*

UltraPure® Lead-Free Bronze, 300 WOG (1/4" thru 2"), 200 WOG (2-1/2" thru 3"), MSS SP-80, Bronze Disc, Threaded  
1/4" thru 3"

### UP967 \*

UltraPure® Lead Free Brass, Brass Disc, 200 WOG  
3/8" thru 3"



IB912



969



UP904 P2

## BRONZE CHECK VALVES HORIZONTAL SWING CHECK

Solder Ends

### IB912

Bronze, 125 SWP-200 WOG, MSS SP-80, Bronze Disc  
3/8" thru 3"

### IB945

Bronze, 150 SWP-300 WOG, MSS SP-80, PTFE Disc  
(Also available w/Bronze Disc)  
1/2" thru 2"

### UP912 \*

UltraPure® Lead-Free Bronze, 300 WOG, MSS SP-80, Bronze Disc  
3/8" thru 3"

### UP968 \*

UltraPure® Lead-Free Brass, 200 WOG, Brass Disc  
3/8" thru 3"

Press x  
Press Ends



### IB904 P2

Bronze, 200 psig @ 250°F, MSS SP-80, Brass Disc  
1/2" thru 2"

### 969

Brass, 200 psig @ 250°F, Brass Disc, Integral Seat  
1/2" thru 2"

### UP904 P2 \*

UltraPure® Lead-Free Bronze, 200 psig @ 250°F, Brass Disc, MSS SP-80  
1/2" thru 2"

### UP969 \*

UltraPure® Lead-Free Brass, Brass Disc, 200 psig @ 250°F  
1/2" thru 2"



UP969



509Y



IB943 P2

## HORIZONTAL SWING CHECK – Y PATTERN

Threaded Ends

### IB949

Bronze, 300 SWP-600 WOG,  
MSS SP-80, Bronze Disc  
1/4" thru 3"

### IB944

Bronze, 200 SWP-400 WOG,  
MSS SP-80, Bronze Disc  
1/4" thru 3"

Press x  
Press Ends



### 509Y P2

Bronze, 200 psig @ 250°F, MSS  
SP-80, Bronze Disc  
1/2" thru 2"

## SPRING-LOADED LIFT CHECK

Threaded Ends

### IB943

Bronze, 250 WOG,  
BUNA Disc  
3/8" thru 2"

### UP943 \*

UltraPure® Lead-Free Bronze,  
PTFE Disc, 250 WOG,  
3/8" thru 2"

Press x  
Press Ends



### IB943 P2

Bronze, 200 psig @ 250°F,  
Buna Disc  
1/2" thru 2"

### UP943 P2 \*

UltraPure® Lead-Free Bronze,  
200 psig @ 250°F, PTFE Disc,  
1/2" thru 2"



IR1140-UL



IR1124-UL



118-FP

## IRON GATE

IR1140-UL  
OS & Y Bronze Trim, 175 WOG  
UL/FM  
2-1/2" thru 8"

## IRON CHECK VALVE

IR1124-UL  
175 WOG, UL/FM, Rubber Disc  
2-1/2" thru 8"

## BRONZE GATE VALVE WITH UL/FM TRIM

118-FP  
OS & Y, UL/FM, NPT Threaded  
1" thru 2"



1550



1560

## CAST STEEL GATE

### 1550CB2

Class 150, Flanged, API 600, ASME B16.34 Design, API 598 Tested, Available in Butt-weld, Consult Factory. 2" thru 24"

### 3050CB2

Class 300, Flanged, API 600, ASME B16.34 Design, API 598 Tested, Available in Butt-weld, Consult Factory. 2" thru 24"

### 6050CB2

Class 600, Flanged, API 600, ASME B16.34 Design, API 598 Tested, Available in Butt-weld, Consult Factory. 2" thru 12"

## CAST STEEL GLOBE

### 1560CB2

Class 150, Flanged, API 623, ASME B16.34 Design, API 598 Tested, Available in Butt-weld, Consult Factory. 2" thru 8"

### 3060CB2

Class 300, Flanged, API 623, ASME B16.34 Design, API 598 Tested, Available in Butt-Weld, Consult Factory. 2" thru 8"

### 6060CB2

Class 600, Flanged, API 623, ASME B16.34 Design, API 598 Tested, Available in Butt-Weld, Consult Factory. 2" thru 6"



1570

## CAST STEEL CHECK

### 1570CB2

Class 150, Flanged, API 594, ASME B16.34 Design, API 598 Tested, Available in Butt-Weld, Consult Factory. 2" thru 12"

### 3070CB2

Class 300, Flanged, API 594, ASME B16.34 Design, API 598 Tested, Available in Butt-Weld, Consult Factory. 2" thru 12"

### 6070CB2

Class 600, Flanged, API 594, ASME B16.34 Design, API 598 Tested, Available in Butt-Weld, Consult Factory. 2" thru 12"

Options/Accessories  
Cast Steel Gate  
Multi-Turn Actuation





IR1138-HI



IR330-HI



IR330-HI



IR116

## IRON GATE

**IR1138 or IR1138-HI**  
125 SWP 200 WOG, Non-Rising Stem, IBBM, MSS SP-70  
Available 2" thru 12"  
HI Available 2" thru 24"

**IR1144-HI**  
125 SWP 200 WOG, Non-Rising Stem, All Iron, MSS SP-70  
Available 2" thru 24"

**IR1140 or IR1140-HI**  
125 SWP 200 WOG, OS & Y, IBBM, MSS SP-70  
Available 2" thru 12"  
HI Available 2" thru 24"

**IR1146-HI**  
125 SWP 200 WOG, OS & Y, All Iron, MSS SP-70  
Available 2" thru 12"

**UP2885A or UP 2885M**  
UltraPure Lead-Free Iron  
125 SWP, 200 WOB, OSPY, All Iron, MSS-SPTD  
A Available 2" thru 12"  
M available 2" thru 12"

**IR913-HI**  
3% Nickel Iron, OS & Y, Iron Body, SS Trim, MSS SP-70  
Available 2" thru 12"

**IR330 or IR330-HI**  
250 WSP 500 WOG, OS & Y, IBBM, MSS SP-70  
Available 2" thru 12"  
HI Available 2" thru 12"

## IRON GLOBE

**IR116 or IR116-HI**  
125 SWP 200 WOG, MSS SP-85  
Available 2" thru 10"  
HI Available 2" thru 10"

**IR313 or IR313- HI**  
250 SWP 500 WOG, IBBM, MSS SP-85  
Available 2-1/2" thru 6"



IR1124



IR1124-LW



IR322



IR9253



IR9354

## IRON CHECK

**IR1124 or IR1124-HI**  
125 SWP 200 WOG, IBBM, MSS SP-71  
Available 2" thru 12"  
HI Available 2" thru 24"

**IR1124-LW**  
125 SWP 200 WOG, IBBM, MSS SP-71, Lever and Weight,  
2" thru 12"

**IR1126-HI**  
125 SWP 200 WOG, All Iron,  
Available 2" thru 24"

**UP2974A or UP2974M**  
UltraPure Lead-Free Iron  
125 SWP 200 WOG, OSPY, All Iron, MSS-SP80  
A Available 2" thru 12"  
M Available 2" thru 12"

**IR1937-HI**  
3% Nickel Iron, 125 SWP, 200 WOG Iron Body, Stainless-Steel Trim, MSS SP-71  
2" thru 12"

**IR322**  
250 SWP 500 WOG, IBBM, MSS SP-71  
2-1/2" thru 6"

## SILENT CHECK

**IR9253**  
Class 125, Wafer-Style Cast-Iron Body, Stainless-Steel Disc, Stainless-Steel Spring,  
Meets Senate Law S3874  
2" thru 10"

**IR9354**  
Class 125, Globe-Style Cast-Iron Body, Stainless-Steel Disc, Stainless-Steel Spring, Meets Senate Law S3874  
2-1/2" thru 42"



967

## BRASS SWING CHECK VALVE

**967**  
200 WOG  
Threaded Ends  
Brass Disc  
Sizes 1/2" thru 4"



945

**968**  
200 WOG  
Solder Ends  
Brass Disc  
Sizes 1/2" thru 2"



547

## BRONZE SPRING LOADED LIFT CHECK

**943**  
250 WOG  
Threaded Ends  
Buna Seat  
Sizes 3/8" thru 2"

**947**  
250 WOG  
Solder Ends  
Buna Seat  
Sizes 3/8" thru 2"

## WATER METER ANGLE GLOBE VALVES

**547**  
Bronze Body with Drain  
125 WOG  
Flare Copper End X Threaded End  
Buna Seat  
Sizes: 3/4" X 3/4" - 1" X 1-3/4"  
X 1/2" - 1" X 3/4"

**548**  
Bronze Body  
125 WOG  
Flare Copper End X Threaded End  
Buna Seat  
Sizes: 3/4" X 3/4" - 1" X 1-3/4"  
X 1/2" - 1" X 3/4"



38

## CHROME-PLATED FROST-PROOF SILL COCKS

**38**  
150 WWP  
Male IPS X Hose End,  
Combination Sweat X IPS  
Buna Seat  
4" thru 14"



445

**58**  
150 WWP  
Combination Sweat X Hose End,  
Male IPS X Hose End  
Buna Seat, Anti-Siphon Vacuum  
Breaker  
6" thru 14"

## BRASS STOP VALVES

**445**  
150 WWP  
Threaded Ends  
Buna-N Seat, Adjustable  
Packing Nut  
Sizes 1/2" & 3/4"

**446**  
150 WWP  
Solder Ends  
Buna-N Seat, Adjustable  
Packing Nut  
Sizes 1/2" & 3/4"



545

## DRAINABLE BRASS STOP VALVES

**545**  
150 WWP  
Threaded Ends  
Buna-N Seat, Adjustable  
Packing Nut  
Sizes 1/2" & 3/4"



546

**546**  
150 WWP  
Solder Ends  
Buna-N Seat, Adjustable  
Packing Nut  
Sizes 1/2" & 3/4"



710

**549**  
150 WWP  
Compression Ends  
Buna-N Seat, Adjustable  
Packing Nut  
Sizes 1/2" & 3/4"

## BRASS HOSE END VALVES

**710**  
150 WWP  
Male IPS X Hose End (1/2"  
Combination Threaded  
& Solder End)  
Buna-N Seat, Adjustable  
Packing Nut  
Sizes 1/2" & 3/4"

**712**  
150 WWP  
Female IPS X Hose End  
Buna-N Seat, Adjustable  
Packing Nut  
Sizes 1/2" & 3/4"

**713**  
150 WWP  
Solder X Hose End  
Buna-N Seat, Adjustable  
Packing Nut  
Sizes 3/4"



1032

## continued BRASS HOSE END VALVES

**1032**  
150 WWP  
Female IPS X Hose End  
Buna-N Seat, Adjustable  
Packing Nut  
Sizes 1/2" & 3/4"



2002

**1034**  
150 WWP  
Solder X Hose End  
Buna-N Seat, Adjustable  
Packing Nut  
Sizes 1/2" & 3/4"

**2002**  
150 WWP  
Male IPS X Hose End  
(1/2" Combination Threaded  
& Solder End)  
Buna-N Seat, Adjustable  
Packing Nut  
T-Handle  
Sizes 1/2" & 3/4"

## BRASS BALL VALVE

**2007**  
150 WWP  
Male IPS X Hose End (1/2"  
Combination Threaded  
& Solder End)  
Teflon® Seat, Adjustable  
Packing Nut  
T-Handle  
Sizes 1/2" & 3/4"

# PLUMBING VALVES



2004

## NO-KINK BRASS BODY

**2004**  
150 WWP  
Male IPS X Hose End  
Buna-N Seat, Adjustable  
Packing Nut  
T-Handle  
Sizes 1/2" & 3/4"



875-01

**2005**  
150 WWP  
Female IPS X Hose End  
Buna-N Seat, Adjustable  
Packing Nut  
T-Handle  
Sizes 1/2" & 3/4"



876-01

## BENT NOSE BRASS BODY

**1035**  
150 WWP  
Female IPS X Hose End  
Buna-N Seat, Adjustable  
Packing Nut  
Sizes 1/2" & 3/4"

## BRASS GAS VALVES CSA APPROVED

**875-01**  
1/2 & 5 psig  
Threaded Ends  
Lever Handle  
PTFE Seats, Chrome Plated Ball  
Sizes 1/2" thru 1"

**876-01**  
1/2 & 5 psig  
Threaded Ends  
T-Handle  
PTFE Seats, Chrome Plated Ball  
Sizes 1/2" & 3/4"



879-01

## continued BRASS GAS VALVES CSA APPROVED

**880**  
1/2 & 5 psig  
Threaded Ends  
Lever Handle  
PTFE Seats, Chrome Plated Ball  
Sizes 1/2" & 3/4"



878-01

**879-01**  
1/2 & 5 psig  
Female IPS X Flare  
Lever Handle  
PTFE Seats, Chrome Plated Ball  
Sizes 3/8" X 3/8" - 1/2" - 1/2"

**878-01**  
1/2 & 5 psig  
Flare X Flare  
Lever Handle  
PTFE Seats, Chrome  
Plated Ball  
Sizes 3/8" X 3/8" - 1/2" - 1/2"



100-25

## BRASS HEATING VALVES WITH HEAT RESISTANT HANDWHEEL

**100-25**  
 15 SWP - 60 psig Hot Water Rating  
 Female IPS X Male IPS  
 Union End, EPDM Disc  
 Adjustable Packing Nut  
 Sizes 1/2" Thru 1-1/2"



200

**200**  
 Gravity Hot Water Rating  
 Female IPS X Male IPS  
 Union End, EPDM Disc  
 Adjustable Packing Nut  
 Sizes 1/2" Thru 1-1/4"



102

## BRONZE HEATING GATE VALVE WITH HEAT RESISTANT HANDWHEEL

**102**  
 125 SWP - 200 WOG (to 353°)  
 Male Union X Female IPS  
 Screw-Over Bonnet,  
 Non-Rising Stem  
 Adjustable Packing Nut,  
 Solid Wedge  
 Sizes 1/2" Thru 1-1/4"

**108**  
 15 SWP - 60 psig Convectector  
 Steam Angle Rating  
 Female IPS X Female IPS  
 Union End, EPDM Disc  
 Adjustable Packing Nut,  
 Solid Wedge  
 Sizes 1/2" & 3/4"



8211-15

## BRASS BALANCE/ CIRCULATOR VALVES & ELBOWS

**8211-15**  
 400 WOG 2-Piece, Threaded Ends,  
 Slotted Blow-Out-Proof Stem,  
 Chrome-Plated Ball  
 PTFE Seats & Packing  
 1/2" thru 1"



300

**300**  
 Female IPS X Male IPS  
 Union End  
 Sizes 1/2" Thru 1-1/4"

**302**  
 Female Solder X Male IPS  
 Union End  
 Sizes 1/2" & 3/4"

## BRONZE BALANCE/ CIRCULATOR VALVES & ELBOWS

**201**  
 60 psig Hot Water Rating  
 Solder X Male Union  
 Blow-Out Proof Stem  
 PTFE Seats, Chrome Plated Ball  
 1/2" thru 1-1/2"



UP8501-16



UP8511H



UP8501H P1

**Options/Accessories**

- UP8501/UP8503
- UP8511/UP8513
- UP8301A/UP8303A
- UP8311A/UP8313A
- Insulator Handle with Memory Stop (16)
- Oval Handle (04)
- Stainless Steel Handle (08)
- Extension Handle with Memory Stop (09)
- Extension Handle (06)
- Memory Stop (02)
- Tee Handle (03)
- Chain Lever (12)
- Locking Handle (07)

## 2-PIECE LEAD-FREE BRONZE BALL VALVES

### Standard Port

**UP8501 / UP8503 \***  
600 WOG, MSS SP-110, Threaded, UP8503 with Stainless Steel Ball & Stem  
1/4" thru 3"

**UP8511 / UP8513 \***  
600 WOG, MSS SP-110, Solder, UP8513 with Stainless Steel Ball & Stem  
3/8" thru 3"

**UP8501 P2 / UP8503 P2 \***  
200 psig @ 250°F, MSS SP-110, Press X Press, UP8503 P2 with Stainless Steel Ball and Stem  
1/2" thru 3"

### Full Port

**UP8501H \***  
600 WOG, Threaded with Hose-End, Cap and Chain  
1/2" and 3/4"

**UP8511H \***  
600 WOG, Solder with Hose-End, Cap and Chain  
1/2" and 3/4"

**UP8301A / UP8303A \***  
600 WOG, MSS SP-110, Threaded, UP8303A with Stainless Steel Ball & Stem  
1/4" thru 2"

**UP8311A / UP8313A \***  
600 WOG, MSS SP-110, Solder, UP8313A with Stainless Steel Ball & Stem  
3/8" thru 3"

**UP8501H P1 \***  
200 psig @ 250°F, MSS SP-110, Press X Hose-End  
1/2" and 3/4"



UP8301A P2-09



UP8901



UPBA-481BXH

**Options/Accessories**

- UP8301A/UP8303A
- Insulator Handle with Memory Stop (16)
- Oval Handle (04)
- Stainless Steel Handle (08)
- Extension Handle with Memory Stop (09)
- Extension Handle (06)
- Memory Stop (02)
- Tee Handle (03)
- Chain Lever (12)
- Locking Handle (07)

- UP8901/UP8911
- UPBA-480B/UPBA-490B
- Insulator Handle with Memory Stop (16)
- Oval Handle (04)
- Stainless Steel Handle (08)
- Extension Handle (06)
- Memory Stop (02)
- Tee Handle (03)
- Locking Handle (07)

## continued 2-PIECE LEAD-FREE BRONZE BALL VALVES

**UP8301A P2 / UP8303A P2 \***  
200 psig @ 250°F, MSS SP-110, Press X Press, UP8303A P2 with Stainless Steel Ball and Stem  
1/2" thru 2"

## 2-PIECE LEAD-FREE BRASS BALL VALVES\*

**UP8901 \*\***  
600 WOG (1/2" thru 2"), 400 WOG (2-1/2" thru 3"), MSS SP-110, UL/CSA Rated to 2", Threaded  
1/4" thru 3"

**UP8911 \*\***  
600 WOG (1/2" thru 2"), 400 WOG (2-1/2" thru 3"), MSS SP-110, Solder  
1/2" thru 3"

### Full Port

**UPBA-480B / UPBA-480S \*\***  
200 psig @ 250°F, MSS SP-110, Press X Press, UPBA-480S with Stainless Steel Ball and Stem  
1/2" thru 4"

**UPBA-480SH \*\***  
200 psig @ 250°F, MSS SP-110, Press X Hose-End  
1/2" thru 3/4"

**UPBA-481B / UPBA-481S \*\***  
200 psig @ 250°F, MSS SP-110, Extension Stem With Memory Stop, Press X Press, UPBA-481S with Stainless Steel Ball and Stem  
1/2" thru 3"



UPBA-490B



UPBA-491B



UP8614

**Options/Accessories**

**UPBA-480B/UPBA-490B**

- Insulator Handle with Memory Stop (16)
- Oval Handle (04)
- Stainless Steel Handle (08)
- Extension Handle (06)
- Memory Stop (02)
- Tee Handle (03)
- Locking Handle (07)

**UP8604/UP8603**

**UP8614/UP8613**

- Insulator Handle with Memory Stop (16)
- Oval Handle (04)
- Stainless Steel Handle (08)
- Extension Handle with Memory Stop (09)
- Extension Handle (06)
- Memory Stop (02)
- Tee Handle (03)
- Chain Lever (12)
- Locking Handle (07)

continued  
**2-PIECE**   
**LEAD-FREE BRASS**  
**BALL VALVES\***

**UPBA-490B / UPBA-490S \*\***  
 200 psig @ 250°F, MSS SP-110, Press X Threaded, UPBA-490S with Stainless Steel Ball and Stem  
 1/2" thru 4"

**UPBA-490SH \*\***  
 200 psig @ 250°F, MSS SP-110, Press X Hose  
 1/2" and 3/4"

**UPBA-491B / UPBA-491S \*\***  
 200 psig @ 250°F, MSS SP-110, Extension Stem with Memory Stop, Press X Threaded, UPBA-491S with Stainless Steel Ball and Stem  
 1/2" thru 2"

**3-PIECE**   
**LEAD-FREE**  
**BRONZE BALL VALVES**  
**Full Port**

**UP8604 / UP8603 \***  
 600 WOG, MSS SP-110, Threaded, UP8603 with Stainless Steel Ball & Stem  
 1/4" thru 3"

**UP8614 / UP8613 \***  
 600 WOG, MSS SP-110, Solder, UP8613 with Stainless Steel Ball & Stem  
 3/8" thru 3"

**UP8604 P2 / UP8603 P2 \***  
 200 psig @ 250°F, MSS SP-110, Press X Press, UP8603 P2 with Stainless Steel Ball & Stem  
 1/2" thru 2"



UP645



UP645 P2



UP667

**LEAD-FREE**   
**BRONZE GATE VALVES**

**Non-Rising Stem**

**UP645 \***  
 300 WOG, MSS SP-80, Threaded Bonnet, Threaded  
 1/4" thru 2"

**UP647 \***  
 300 WOG, MSS SP-80, Threaded Bonnet, Solder  
 3/8" thru 2"

**UP645 P2 \***  
 200 psig @ 250°F, MSS SP-80, Threaded Bonnet, Press X Press  
 1/2" thru 2"

**Rising Stem**

**UP640 \***  
 300 WOG, MSS SP-80, Threaded Bonnet, Threaded  
 1/4" thru 2"

**UP635 \***  
 300 WOG, MSS SP-80, Threaded Bonnet, Solder  
 1/2" thru 2"

**UP640 P2 \***  
 200 psig @ 250°F, MSS SP-80, Threaded Bonnet, Press X Press  
 1/2" thru 2"

**LEAD-FREE**   
**BRASS GATE VALVES**

**Non-Rising Stem**

**UP667 \***  
 200 WOG, Threaded Bonnet, Threaded  
 1/4" thru 2"

**UP668 \***  
 200 WOG, Threaded Bonnet, Solder  
 1/2" thru 2"

\* Meets Senate law S3874. IAPMO tested and certified to NSF/ANSI 372 for "lead-free" compliance.

\*\*Tested and Certified by IAPMO R & T to NSF/ANSI 61 and NSF/ANSI 372 for Lead Free Compliance.



UP440 P2

## LEAD-FREE BRONZE GLOBE VALVES

**UP440 \***  
300 WOG, MSS SP-80, Threaded Bonnet, Threaded  
1/8" thru 2"

**UP418 \***  
300 WOG, MSS SP-80, Threaded Bonnet, Solder  
3/8" thru 2"

**UP440 P2 \***  
200 psig @ 250°F, Press X Press, MSS SP-80, Threaded Bonnet, Press X Press  
1/2" thru 2"



UP418



UP904

## LEAD-FREE BRONZE CHECK VALVES

Horizontal Swing Check

**UP904 \***  
300 WOG, Bronze Disc, MSS SP-80, Threaded  
1/4" thru 3"

**UP912 \***  
300 WOG, Bronze Disc, MSS SP-80, Solder  
3/8" thru 3"

**UP904 P2 \***  
300 WOG, Bronze Disc, MSS SP-80, Press X Press  
1/2" thru 2"

**UP967 \***  
Brass, 200 WOG, Brass Disc, Threaded  
3/8" thru 3"

**UP968 \***  
Brass, 200 WOG, Brass Disc, Solder  
3/8" thru 3"



UP968



UP969



UP943P2



IR9253



IR9354

## continued LEAD-FREE BRONZE CHECK VALVES

Horizontal Swing Check

**UP969 \***  
Bronze, 200 psig @ 250°F, Brass Disc, Press x Press  
1/2" thru 2"

## LEAD-FREE SPRING LOAD LIFT CHECK VALVES

**UP943 \***  
PTFE Disc, 250 WOG, Threaded  
3/8" thru 2"

**UP943 P2 \***  
200 psig @ 250°F, PTFE Disc, Press X Press  
1/2" thru 2"

## SILENT CHECK

**IR9253 \***  
Class 125, Wafer-Style Cast-Iron Body, Stainless-Steel Disc, Stainless-Steel Spring, Meets Senate Law S3874  
2" thru 10"  
(Also Available Class 250)

**IR9354 \***  
Class 125, Globe-Style Cast-Iron Body, Stainless-Steel Disc, Stainless-Steel Spring, Meets Senate Law S3874  
2-1/2" thru 42" (Also Available Class 250)





6411-00/6411-01/6411-03  
(PICTURED WITH LEVER HANDLE)



6411-03

## LEAD-FREE COMMERCIAL BUTTERFLY

**6411-00/6411-01/6411-03 \***  
Cast Iron Body, Lug Style, Aluminum Bronze Disc, EPDM Liner, Bi-Directional Dead-End Service 200 psig Max IAPMO Tested And Certified Against NSF/ANSI-372 For "Lead-Free" Compliance. 2" thru 12"

**6411-00/6411-03 \***  
Cast Iron Body, Lug Style, Aluminum Bronze Disc, EPDM Liner, Bi-Directional Dead-End Service 200 psig Max 2" thru 12", Uni-Directional Dead-End Service 150 psig Max IAPMO Tested And Certified Against NSF/ANSI-372 For "Lead-Free" Compliance. 14" thru 24"

**5000 Series \***  
Cast Iron Body, Lug Style, Aluminum Bronze Disc, EPDM Liner, Bi-Directional Dead-End Service 200 psig Max 2" thru 12", Uni-Directional Dead-End Service 150 psig Max IAPMO Tested And Certified Against NSF/ANSI-372 For "Lead-Free" Compliance. 14" thru 24"

**Options/Accessories**  
Rubber-Lined Butterfly  
Electric Actuation  
Pneumatic Actuation



HP1LSS WITH GEAR OPERATOR

## LEAD-FREE HIGH PERFORMANCE BUTTERFLY

**HP1LSS4212/HP3LSS4212/  
HP1LSS4213/HP3LSS4213**  
Stainless Steel Body, Lug Style, Stainless Steel Disc, RPTE Seat, bi-directional dead-end service and double offset design. ANSI Class 150 and 300 available in sizes 2 1/2" - 24". Certified by IAPMO R&T to NSF/ANSI 61 and NSF/ANSI 372 for low lead requirements.

\* Meets Senate law S3874. IAPMO tested and certified to NSF/ANSI 372 for "lead-free" compliance.

## QUALITY IS MORE THAN WHAT MEETS THE EYE.

For the most part, engineering is invisible. Engineers or contractors know what a valve looks like, and knows what it does, but typically, they can't see the superiority designed into each and every Hammond Valve product. Hammond Valve demands excellence in our engineering department, with groups operating in each of our facilities to support the manufacturing of all products. These engineers provide design services as well, translating the critical specifications and processes into manufactured items – a key step where other suppliers, without our depth of experience, often fall flat.

Hammond Valve's well-staffed engineering department is supported by state-of-the-art computer tools, from 3D design using Solidworks, to finite element analysis (FEA) using COSMOS, to computational fluid dynamics (CFD) using CF Design software, to automated data acquisition in our laboratories using Labview. We operate our own fire-test facility to help us achieve and maintain the most advanced fire-safe designs to the latest API and other standards.

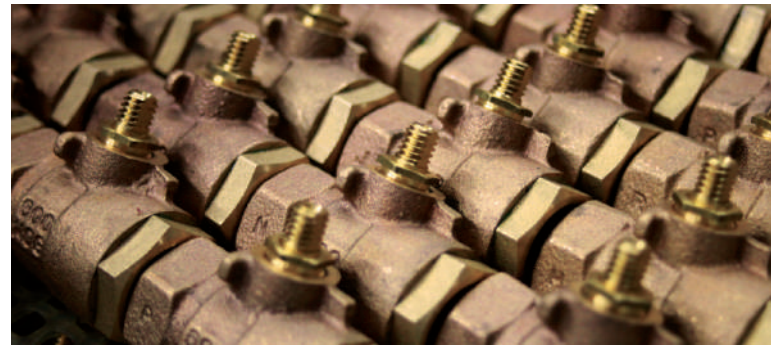

products. Others are turnkey product-development projects designed to meet the demanding safety needs or harsh application requirements of a specific user.

Hammond Valve's background in the Commercial and Plumbing markets should provide you with confidence to entrust your most difficult engineering applications to our experienced staff, helping you grow your business and providing you with the great service you deserve.

If you have a service that is constantly causing you concern, give us a call. Our application engineering and technical service teams stand ready to help.

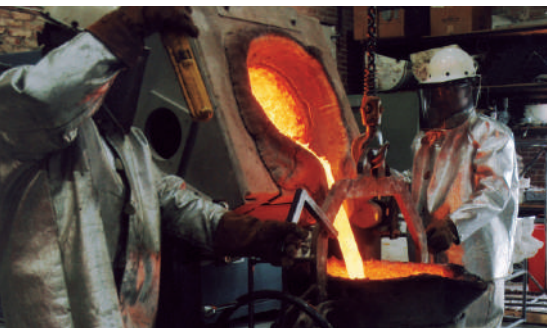

For more information on our capabilities or assistance with a specific problem, contact your Hammond Valve sales representative (<http://www.HammondValve.com/index.php/rep>s). Their experience and industry knowledge will simplify finding a solution to your product and application requirements.

We translate our 3D designs directly to tool paths, both on our shop floor and in our pattern shop, which supports our in-house foundry operation. These capabilities also service our engineering and contracting customers, who use these models in their equipment and building designs.

In addition, Hammond Valve has extensive experience in the development of products for specific OEMs or demanding service conditions. Some are minor modifications to existing



This condensed catalog is not a complete depiction of Hammond Valve's products or capabilities. Please contact the factory for special service conditions or additional accessories and options.

# OUR BEST WORK IS [UNDERCOVER]

## INSULATOR/MS®. YOUR HIDDEN LINE OF DEFENSE AGAINST CONDENSATION DAMAGE.

Standard insulation leaves a gap at valve sites that can lead to condensation, mildew and system contamination. So protect your installations with INSULATOR/MS® ball valve handles that cover exposed valve parts, close gaps and add a layer of insulating power.

INSULATOR also reduces service time. Its reliable memory stop adjusts with a few quick turns of a hex wrench, instead of needing disassembly. Specifying multiple projects is easy, too, with INSULATOR's versatile +15°F to +250°F operating range. The handles are tested and certified to UL 2043 and is UL listed for installation in air-handling plenums. Uncover more product info at [MilwaukeeValve.com](http://MilwaukeeValve.com), [HammondValve.com](http://HammondValve.com) and [UltraPureNoLeadValves.com](http://UltraPureNoLeadValves.com).



16550 West Stratton Drive, New Berlin, WI 53151  
Phone 262-432-2700 | Fax 262-432-2701  
[www.MilwaukeeValve.com](http://www.MilwaukeeValve.com) | [www.HammondValve.com](http://www.HammondValve.com)  
[www.UltraPureNoLeadValves.com](http://www.UltraPureNoLeadValves.com)



© 2019, Milwaukee Valve Company  
INSULATOR/MS, UltraPure, Hammond Valve and Milwaukee Valve logos are  
all registered trademarks of Milwaukee Valve Company.



## WEBSITE REDUCES ERRORS AND SAVES TIME

Simplify your projects and reduce ordering errors by building your own valves, courtesy of Hammond Valve's online Advanced Search feature.

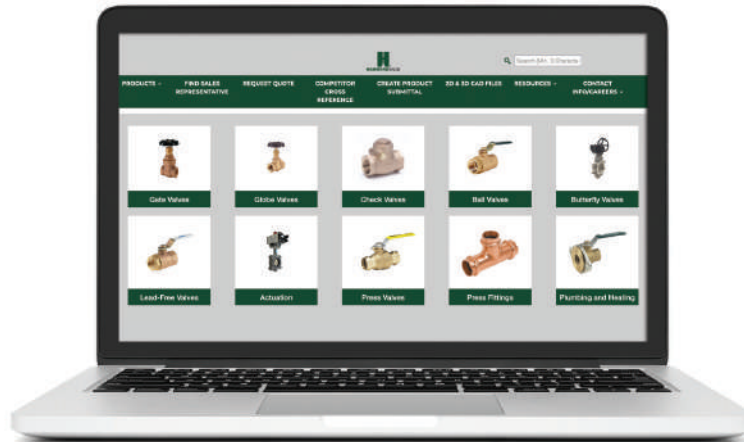

You know the service, and Hammond Valve has the valves and the options to solve your service issues. Found at [www.HammondValve.com](http://www.HammondValve.com), the Advanced Search function acts as an online configurator, laying out all available options in one easy-to-use format. You select the type of valve you require, and choose the available materials, sizes, options, etc. Once all options are selected, you are given the model numbers for the valves that meet your criteria. When you know exactly what you are ordering, the result is fewer returns, lower shipping costs, and all-around time savings. The Advanced Search is especially beneficial in selecting Butterfly and Industrial valves, which both offer thousands of different valve and option combinations.

In addition, the website contains specification data for virtually every Hammond Valve product, and has the capacity to produce product submittals and is a repository for a wide variety of product information, including price lists, literature downloads, technical service bulletins, competitive cross reference and even provides links to YouTube instruction and installation videos.

And if you require assistance in selecting a valve, ball, seat, actuator or any of many other options, assistance is available from your Hammond Valve sales representative. Try it out at [www.HammondValve.com](http://www.HammondValve.com).



16550 West Stratton Drive,  
New Berlin, WI 53151  
Phone 262-432-2700 • Fax 262-432-2701  
[www.HammondValve.com](http://www.HammondValve.com)