

GLOBE VALVE

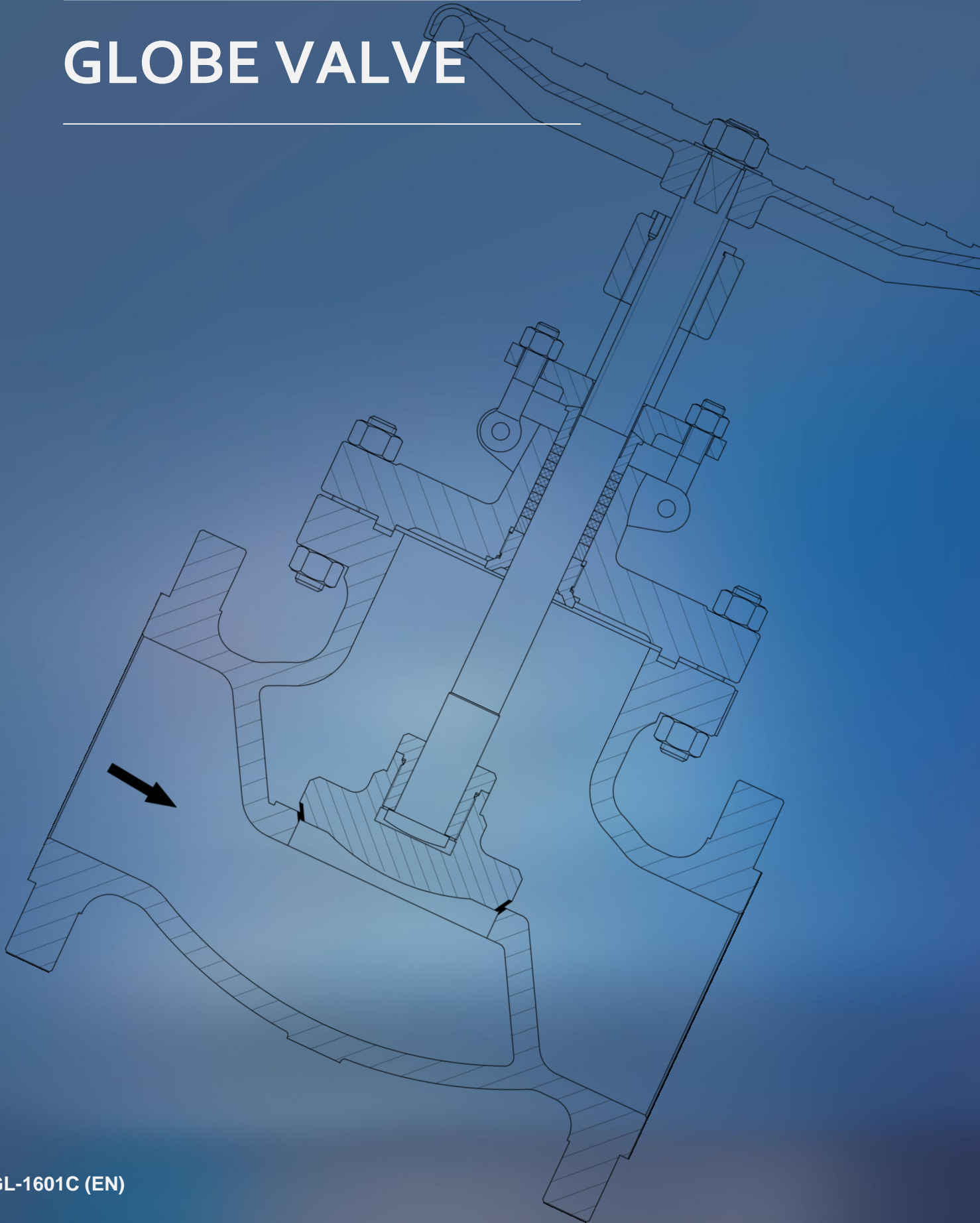

ABOUT US

FBV Inc. is an ISO 9001 certified company specializing in manufacturing industrial valves including ball valves, gate valves, globe valves, check valves, plug valves and butterfly valves in carbon steel, stainless steel, duplex stainless and alloy materials. Our products conform to the latest industry standards in accordance to ANSI, ASME and API.

FBV today has over 600,000 square feet of manufacturing facilities. Through its conviction to provide only the finest quality products and services to match the need of our customers, FBV has now established itself as a serious player in the valve business.

FBV INC has sold worldwide in North America, Europe, South America, South Asia, Africa and the Middle East. We consider product quality and customer satisfaction as our highest priority. We look forward to new customer relationships by providing value, quality, customer service, honesty, integrity and the commitment to maintain product consistency with each and every order.

MISSION STATEMENT

We at FBV, Inc. commit to taking ACTION:

- Adopt the latest technology to take the product quality to the next level;
- Consistently provide on-time services to our customers;
- Train and develop talented people with strong work ethics to deliver effective performance;
- Improve and enhance engineering designs to ensure product performance;
- Optimize management systems and increase productivity;
- Never forget our customer and employee needs.



GLOBE VALVE

TABLE OF INDEX	PAGE
Introduction, <i>Features</i>	3
Scope of Products	4
Overview Globe Valve (Bolted Bonnet)	5
Dimensions and Weights	6
<i>Class 150 (PN 20)</i>	6
<i>Class 300(PN 50)</i>	7
<i>Class 600(PN 100)</i>	8
<i>Class 900(PN 150)</i>	9
<i>Class 1500(PN 250)</i>	10
Overview Globe Valve (Pressure Seal Bonnet)	11
Dimensions and Weights	12
<i>Class 900 (PN 150)</i>	12
<i>Class 1500 (PN 150)</i>	13
<i>Class 2500 (PN 250)</i>	14
Valve Figure Number, <i>How To Order</i>	15-16

This page is intentionally left blank.



Design of Body -Bonnet Connection

Bolted bonnet is normally applied on CL150~CL900, body seal is defaulted by gasket and RTJ ring; Pressure seal bonnet is applied on CL1500~CL2500 with pressure seal ring for body seal.

Design of Packing

By default graphite packing is used, PTFE packing can be used on corrosive media. API 622 fugitive emission packing will be used upon request.

Design of Backseat

Renewable back seat is applied on all carbon steel and low alloy steel valve, however, body back seat is only applied for stainless steel valve.

Design of Actuation

Hand wheel and gear box are normally designed for cast globe valve based on different size and pressure rating; Electric, pneumatic or Chain wheel operation can be provided upon request.

INTRODUCTION

FBV cast globe valve offers T type body by default with rising stem and hand wheel. It blocks the flow of pipeline through the rotation and lifting of hand wheel as well as stem to drive the lift of disc. The globe valve has the feature of long service life since there is no relative friction between disc and body sealing surface.

Bolted bonnet, pressure bonnet, bellow seal bonnet, high/low temperature extended bonnet and ISO 15848 fugitive emission designed valves are available upon different request of services.

Design of Disc

Single disc is normally adopted on cast globe valve, the medium flows from the bottom to the top; double disc is just applied while larger pressure difference or bigger size of valve, the medium flows from top to the bottom.

Plug type disc can be provided upon request.

Design of Seat

FBV cast globe valve is defaulted by non-renewable body seat, renewable seat is provided upon request only.



GLOBE VALVE

OVERVIEW (Bolted Bonnet)

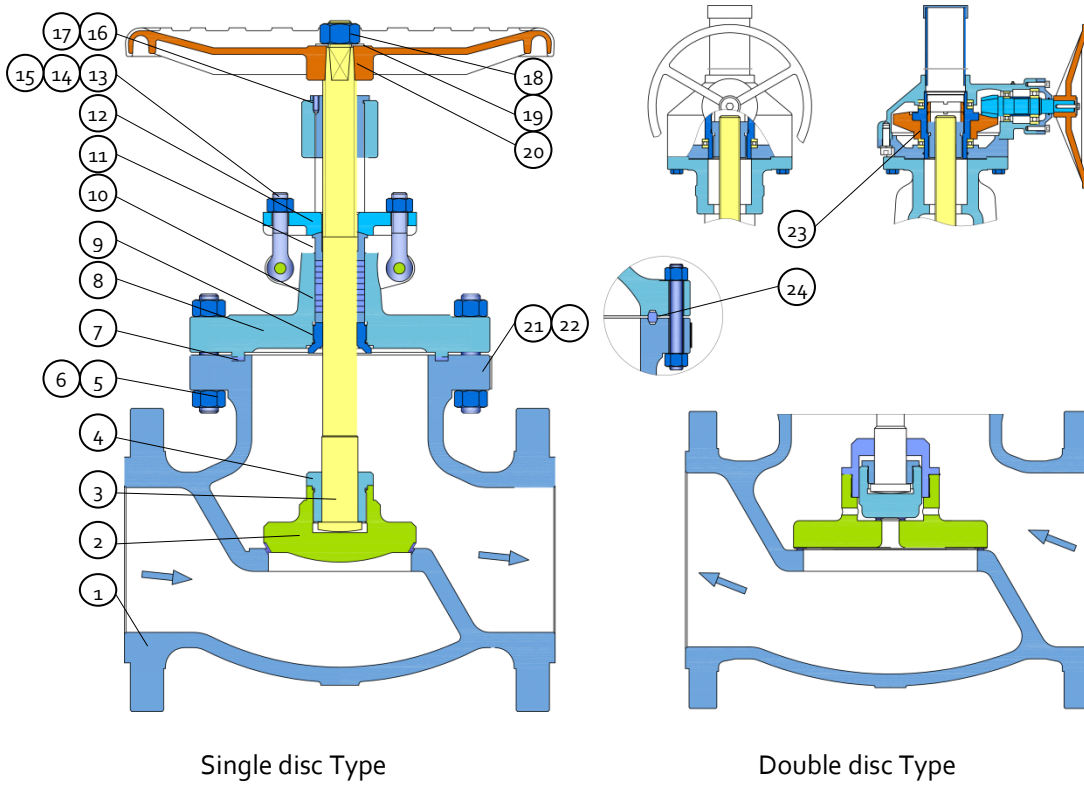

Part List

1 Body	7 Gasket	13 Eye Bolt	19 Washer
2 Disc	8 Bonnet	14 Nut	20 Handwheel
3 Stem	9 Backseat	15 Pin	21 Rivet
4 Sleeve	10 Packing	16 Stem Nut	22 Nameplate
5 Stud	11 Gland	17 Handwheel Nut	23 Gear
6 Nut	12 Gland Flange	18 Nut	24 Octagonal Ring

Standards

Design & Manufacture BS 1873, API 623, ASME B16.34

Face-to-face ASME B16.10

End Dimension ASME B16.5 (RF, RTJ),
ASME B16.47 (RF, RTJ)
ASME B16.25 (BW)

Test & Inspection API 598

Typical Materials
 Body, Bonnet, Disc (Casting): A216 WCB, A351 CF3, CF8, CF3M, CF8M, A995 4A, 5A, A352 LCB, LCC, LC2
 (Forging): A105, A350 LF2, LF3, LF5, A182 F304, F304L, F316, F316L, F51, F53, F5, F11, F22, F91, Monel, Inconel, Hastelloy

Stem A182 F6a, F304, F304L, F316, F316L, F51, F53, F55 Monel, Inconel, Hastelloy

GLOBE VALVE

DIMENSIONS AND WEIGHTS (Bolted Bonnet)

ASME CLASS 150 (PN 20)

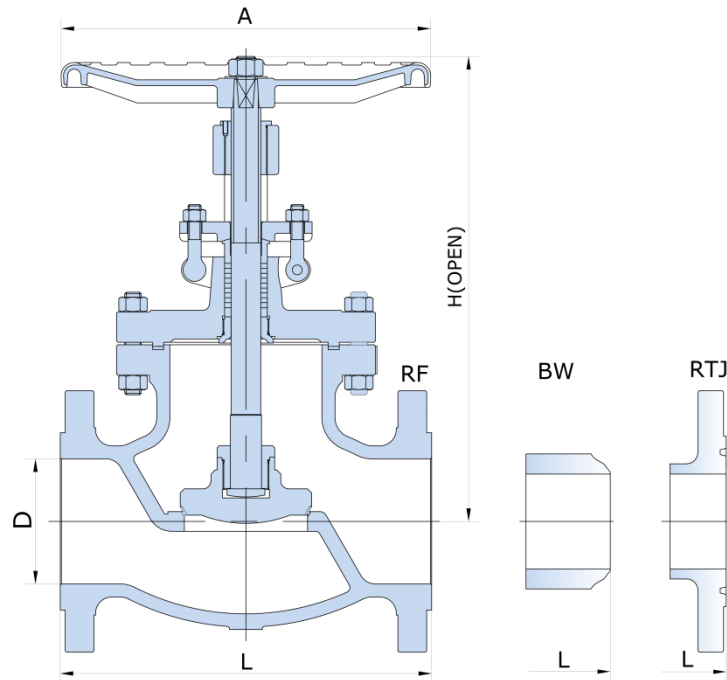

ASME CLASS 150 (PN 20)

Size in/mm	D	L			H	W	Weight
		RF	RTJ	BW			RF/BW (lb/kg)
2	2	8	8.5	8	14.3	7.87	37/34
50	51	203	216	203	363	200	17/15.5
2 1/2	2.5	8.5	9	8.5	15.55	9.84	53/48
65	64	216	229	216	395	250	24/22
3	3	9.5	10	9.5	16.65	9.84	75/68
80	76	241	254	241	423	250	34/31
4	4	11.5	12	11.5	19	11.81	104/95
100	100	292	305	292	483	300	47/43
5	5	14	14.53	14	20.67	15.75	154/141
125	125	356	369	356	525	400	70/64
6	6	16	16.5	16	22.52	15.75	187/172
150	150	406	419	406	572	400	85/78
8	8	19.5	20	19.5	26.65	17.72	275/220
200	203	495	508	495	677	450	125/110
10	10	24.5	25	24.5	32.87	19.69	557/524
250	250	622	635	622	835	500	253/238
12	12	27.5	28	27.5	39.17	23.62	802/753
300	305	698	711	698	995	600	364/342
14	14	31	31.5	31	40.16	-	1123/1048
350	337	787	800	787	1020	-	510/476
16	15.24	36	36.5	36	41.34	-	1630/1487
400	387	914	927	914	1050	-	740/675
18	17.24	38.5	39	38.5	50.6	-	1773/1652
450	438	978	991	978	1285	-	805/750
20	19.25	38.5	39	38.5	58.27	-	1872/1729
500	489	978	991	978	1480	-	850/785
24	23.27	51	51.5	51	68.11	-	2709/2434
600	591	1295	1308	1295	1730	-	1230/1105

The dimension and weights are for reference only and subject to change without notice.

1. For more dimensional information, please contact our sales representative.
2. "W" on above schematic is the diameter for hand wheel, the one without dimension on the table above is defaulted by gear operation.

GLOBE VALVE

DIMENSIONS AND WEIGHTS (Bolted Bonnet)

ASME CLASS 300 (PN 50)

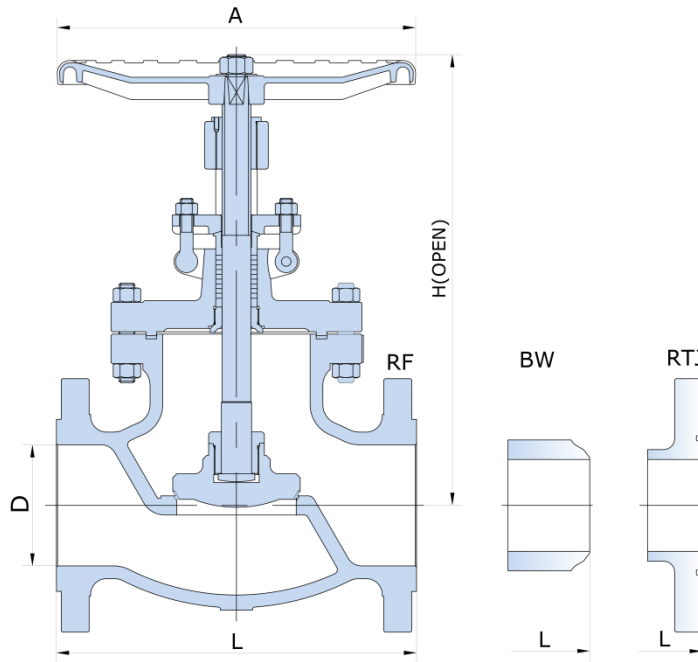

ASME CLASS 300 (PN 50)

Size in/mm	D	L			H	W	Weight
		RF	RTJ	BW			RF/BW (lb/kg)
2	2	10.5	11.14	10.5	14.72	7.87	64/57
50	51	267	283	267	374	200	29/26
2 1/2	2.5	11.5	12.13	11.5	15.55	9.84	84/68
65	64	292	308	292	395	250	35/31
3	3	12.5	13.15	12.5	17.76	11.81	104/90
80	76	318	334	318	451	300	47/41
4	4	14	14.65	14	20.16	13.78	123/112
100	100	356	372	356	512	350	56/51
5	5	15.75	16.38	15.75	21.26	13.78	148/130
125	125	400	416	400	540	350	67/59
6	6	17.5	18.11	17.5	25	17.72	278/253
150	150	444	460	444	635	450	126/115
8	8	22	22.64	22	26.85	19.7	529/474
200	203	559	575	559	682	500	240/215
10	10	24.5	25.12	24.5	32.87	19.7	1233/1167
250	250	622	638	622	835	500	560/530
12	12	28	28.62	28	33.66	19.7	1586/1482
300	305	711	727	711	855	500	720/673
14	14	33	33.62	33	37.4	-	-
350	337	838	854	838	950	-	-
16	15.24	34	34.65	34	43.3	-	-
400	387	864	880	864	1100	-	-
18	17	38.5	39.13	38.5	45.28	-	-
450	432	978	994	978	1150	-	-
20	19	40	40.75	40	47.24	-	-
500	483	1016	1035	1016	1200	-	-
24	23	53	53.86	53	51.18	-	-
600	584	1346	1368	1346	1300	-	-

The dimension and weights are for reference only and subject to change without notice.

1. For more dimensional information, please contact our sales representative.
2. "W" on above schematic is the diameter for hand wheel, the one without dimension on the table above is defaulted by gear operation.

GLOBE VALVE

DIMENSIONS AND WEIGHTS (Bolted Bonnet)

ASME CLASS 600 (PN 100)

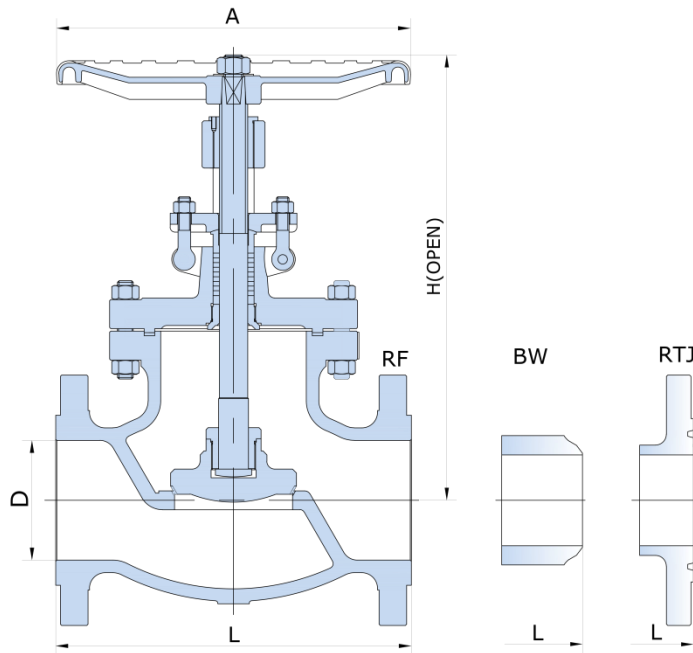

ASME CLASS 600 (PN 100)

Size in/mm	D	L			H	W	Weight
		RF	RTJ	BW			RF/BW (lb/kg)
2	2	11.5	11.63	11.5	15.16	441	75/66
50	51	292	295	292	385	200	34/30
2 ½	2.5	13	13.13	13	16.93	551	99/88
65	64	330	333	330	430	250	50/45
3	3	14	14.13	14	18.7	617	152/137
80	76	356	359	356	475	280	69/62
4	4	17	17.13	17	26.97	661	286/267
100	100	432	435	432	685	300	130/121
5	5	20	20.12	20	30.31	881	419/385
125	125	508	511	508	770	400	190/175
6	6	22	22.13	22	35.43	991	551/518
150	150	559	562	559	900	450	250/235
8	7.87	26	26.13	26	35.94	1100	1002/947
200	200	660	663	660	913	500	455/430
10	9.76	31	31.13	31	41.73	23.62	1806/1692
250	248	787	790	787	1060	600	820/768
12	11.73	33	33.13	33	48.23		
300	298	838	841	835	1225		
14	12.87	35	35.12	35	52.28		
350	327	889	891	889	1328	-	
16	14.76	39	39.13	39	61		
400	375	991	994	991	1550	-	
18	16.5	43	43.13	430	66.93		
450	419	1092	1095	1092	1700	-	
20	18.27	47	47.25	47	70.87		
500	464	1194	1200	1194	1800	-	

The dimension and weights are for reference only and subject to change without notice.

1. For more dimensional information, please contact our sales representative.
2. "W" on above schematic is the diameter for hand wheel, the one without dimension on the table above is defaulted by gear operation.

GLOBE VALVE

DIMENSIONS AND WEIGHTS (Bolted Bonnet)

ASME CLASS 900 (PN 150)

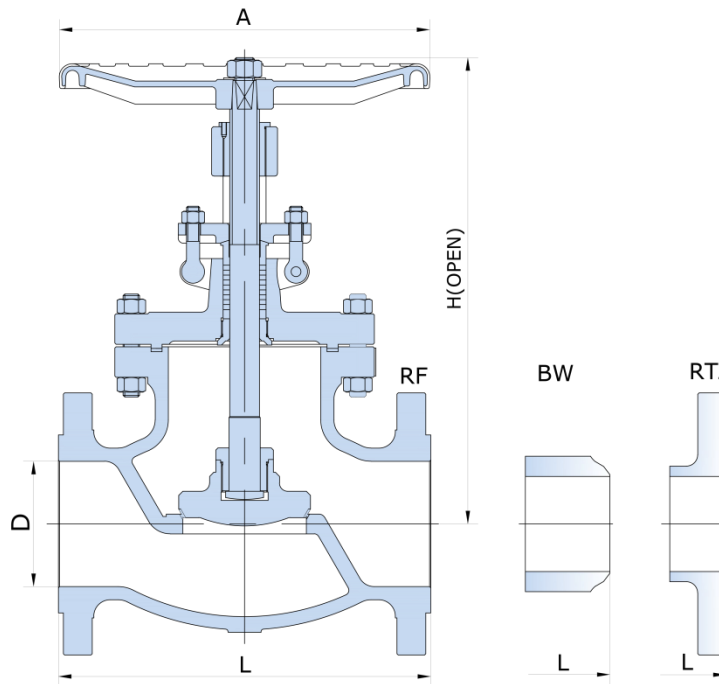

ASME CLASS 900 (PN 150)

Size in/mm	D	L			H	W	Weight
		RF	RTJ	BW			RF/BW (lb/kg)
2	1.87	14.5	14.63	14.5	17.5	9.84	152/143
50	47.5	368	371	368	445	250	69/65
2 ½	2.24	16.5	16.62	16.5	19.5	11.81	231/216
65	57	419	422	419	502	300	105/98
3	2.87	15	15.13	15	21	13.78	238/220
80	73	381	384	381	533	350	108/100
4	3.86	18	18.13	18	24.5	15.75	352/319
100	98	457	460	457	622	400	160/145
5	4.76	22	22.13	22	27.16	17.72	617/562
125	121	559	562	559	690	450	280/255
6	5.75	24	24.13	24	29.5	19.7	771/711
150	146	610	613	610	750	500	350/323
8	7.48	29	29.13	29	36.5	19.7	1564/1487
200	190	737	740	737	927	500	710/675
10	9.37	33	33.13	33	44.88	-	
250	238	838	841	838	1140	-	
12	11.1	38	38.13	38	53.12	-	
300	282	965	968	965	1350	-	
14	12.24	40.5	40.88	40.5	55.12	-	
350	311	1029	1039	1029	1400	-	
16	14	44.5	44.88	44.5	63	-	
400	356	1130	1140	1130	1600	-	
18	15.75	48	48.5	48	68.9	-	
450	400	1219	1232	1219	1750	-	
20	17.52	52	52.5	52	72.83	-	
500	445	1321	1334	1321	1850	-	

The dimension and weights are for reference only and subject to change without notice.

- For more dimensional information, please contact our sales representative.
- "W" on above schematic is the diameter for hand wheel, the one without dimension on the table above is defaulted by gear operation.

GLOBE VALVE

DIMENSIONS AND WEIGHTS (Bolted Bonnet)

ASME CLASS 1500 (PN 250)

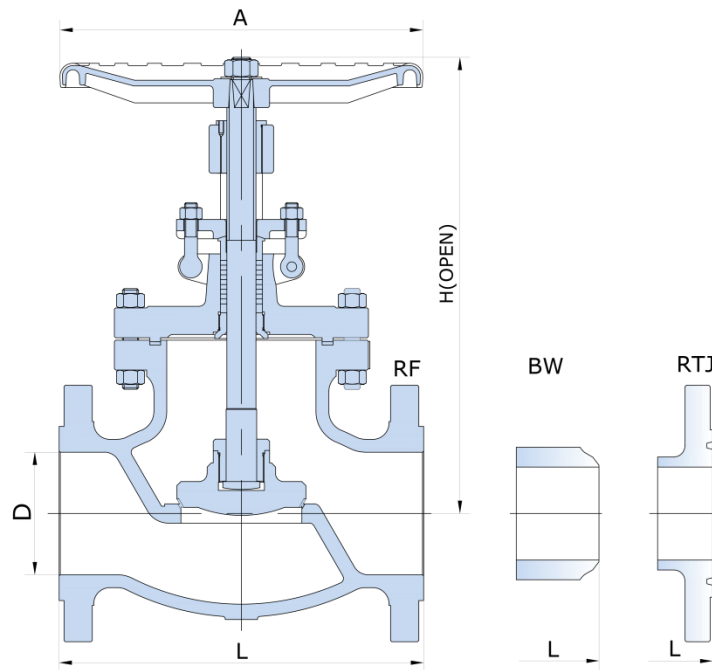

ASME CLASS 1500 (PN 250)

Size in/mm	D	L			H	W	Weight
		RF	RTJ	BW			RF/BW (lb/kg)
2	1.87	14.5	14.61	14.5	16.93	11.81	161/150
50	47.5	368	371	368	430	300	73/68
2 1/2	2.24	16.5	16.61	16.5	19.69	13.78	253/231
65	57	419	422	419	500	350	115/105
3	2.76	18.5	18.62	18.5	29.53	15.75	324/291
80	70	470	473	470	750	400	147/132
4	3.58	21.5	21.61	21.5	32.28	17.72	436/319
100	91	546	549	546	820	450	198/182
5	4.73	26.5	26.61	26.5	34.65	19.7	771/731
125	111	673	676	673	880	500	350/332
6	5.35	27.75	28	27.75	35.83	23.6	1123/1068
150	136	705	711	705	910	600	510/485
8	7	32.75	33.15	32.75	39.96	-	-
200	178	832	842	832	1015	-	-
10	8.74	39	39.41	39	40.75	-	-
250	222	991	1001	991	1035	-	-
12	10.35	44.5	45.12	44.5	53.15	-	-
300	263	1130	1146	1130	1350	-	-
14	11.38	49.5	50.24	49.5	57.48	-	-
350	289	1259	1276	1259	1460	-	-
16	13	54.5	55.35	54.5	61	-	-
400	330	1384	1406	1384	1550	-	-
18	14.61	60.5	61.38	60.5	64.57	-	-
450	371	1537	1559	1537	1640	-	-
20	16.38	65.5	66.38	65.5	66.93	-	-
500	416	1664	1686	1664	1700	-	-

The dimension and weights are for reference only and subject to change without notice.

1. For more dimensional information, please contact our sales representative.
2. "W" on above schematic is the diameter for hand wheel, the one without dimension on the table above is defaulted by gear operation.

GLOBE VALVE

OVERVIEW (Pressure Seal Bonnet)

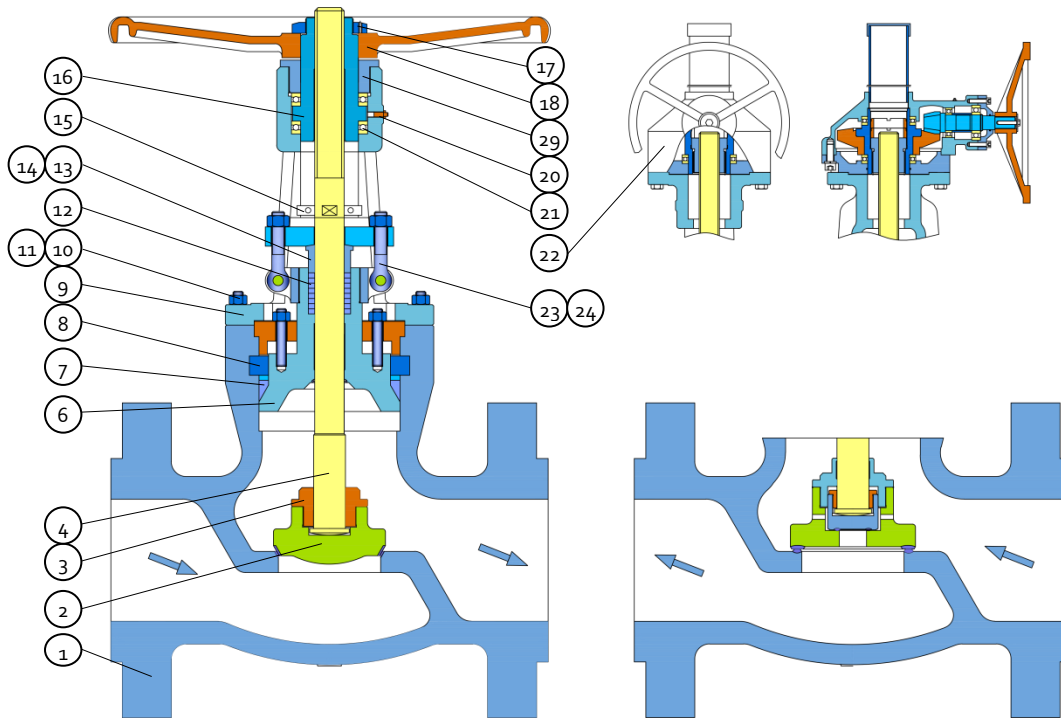

Single Disc Type

Double Disc Type

Part List

1 Body	6 Seal ring	11 Nut	16 Stem Nut	21 Bear
2 Disc	7 Split ring	12 Packing	17 Handwheel Nut	22 Gear
3 Disc Nut	8 Split ring	13 Gland	18 Handwheel	23 Eyes Bolt
4 Stem	9 Yoke	14 Gland flange	19 Bear Gland	24 Nut
5 Bonnet	10 Stud	15 Fixture Block	20 Grease Nipple Nut	

Standards

Design & Manufacture	ASME B16.34, MSS SP-144	
Face-to-face	ASME B16.10	
End Dimension	ASME B16.5(RF, RTJ) ASME B16.47(RF, RTJ) ASME B16.25 (BW)	
Test & Inspection	API 598, ASME B16.34	
Typical Materials	Body,	(Casting) A216 WCB, A351 CF3, CF8, CF3M, CF8M, A995 4A, 5A, A352 LCB, LCC, LC
	Bonnet, Disc	(Forging) A105, A350 LF2, LF3, LF5, A182 F304, F304L, F316, F316L, F51, F53, F5, F11, F22, F91, Monel, Inconel, Hastelloy
	Stem	A182 F6a, F304, F304L, F316, F316L, F51, F53, F55, Monel, Inconel, Hastelloy

GLOBE VALVE

DIMENSIONS AND WEIGHTS (Pressure Seal Bonnet)

ASME CLASS 900 (PN 150)

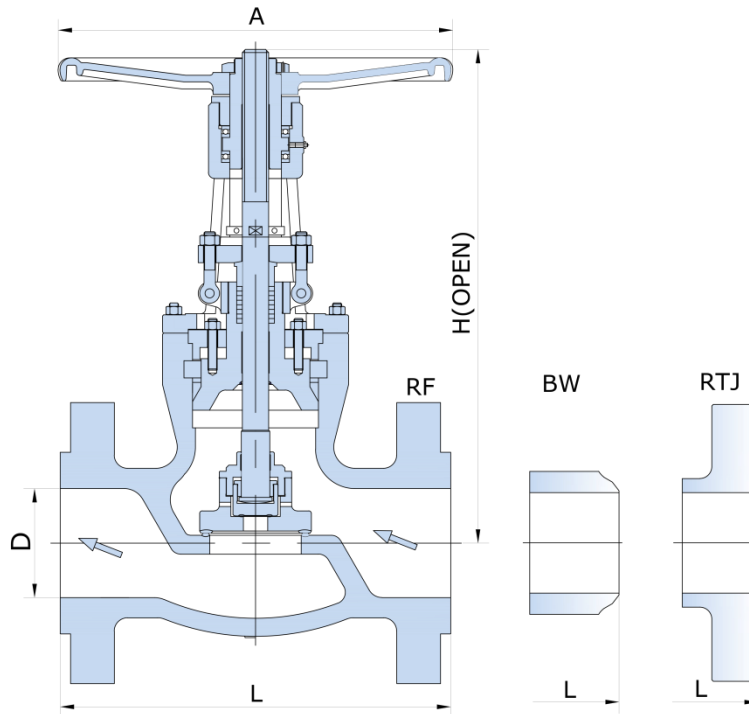

ASME CLASS 900 (PN 150)

Size in/mm	D	L			H	W	Weight
		RF	RTJ	BW			RF/BW (lb/kg)
2 50	1.87 47.5	14.5 368	14.63 371	8.5 216	17.5 445	9.84 250	152/143 69/65
2 1/2 65	2.24 57	16.5 419	16.62 422	10 254	19.5 502	11.81 300	231/216 105/98
3 80	2.87 73	15 381	15.13 384	12 305	21 533	13.78 350	238/220 108/100
4 100	3.86 98	18 457	18.13 460	14 356	24.5 622	15.75 400	352/319 160/145
5 125	4.76 121	22 559	22.13 562	17 432	27.16 690	17.72 450	617/562 280/255
6 150	5.75 146	24 610	24.13 613	20 508	29.5 750	19.7 500	771/711 350/323
8 200	7.48 190	29 737	29.13 740	26 660	36.5 927	19.7 500	1564/1487 710/675
10 250	9.37 238	33 838	33.13 841	31 787	44.88 1140	-	-
12 300	11.1 282	38 965	38.13 968	36 914	53.12 1350	-	-
14 350	12.24 311	40.5 1029	40.88 1038	39 991	55.12 1400	-	-
16 400	14 356	44.5 1130	44.88 1140	43 1092	63 1600	-	-
18 450	15.75 400	48 1219	48.5 1232	-	68.9 1750	-	-
20 500	17.52 445	52 1321	52.5 1334	-	72.83 1850	-	-

The dimension and weights are for reference only and subject to change without notice.

1. For more dimensional information, please contact our sales representative.
2. "W" on above schematic is the diameter for hand wheel, the one without dimension on the table above is defaulted by gear operation.

GLOBE VALVE

DIMENSIONS AND WEIGHTS (Pressure Seal Bonnet)

ASME CLASS 1500 (PN 250)

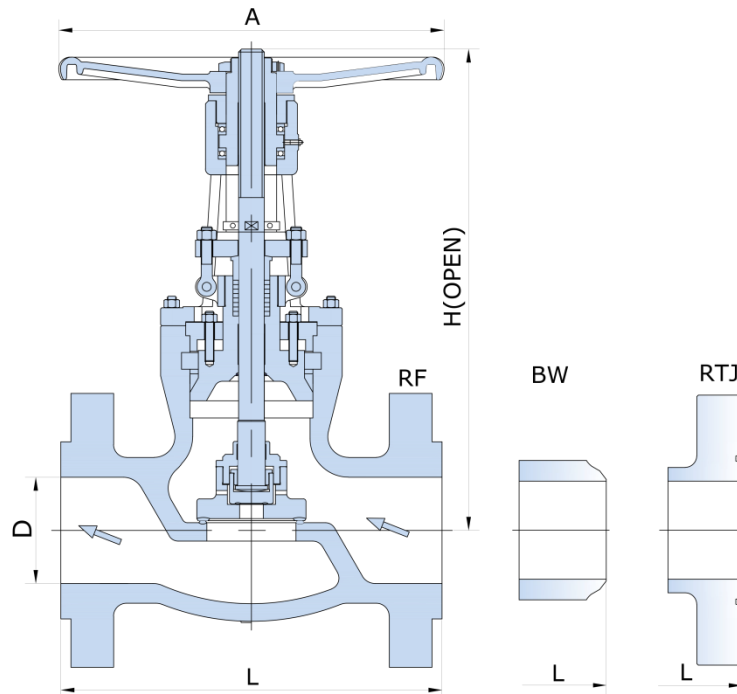

ASME CLASS 1500 (PN 250)

Size in/mm	D	L			H	W	Weight
		RF	RTJ	BW			RF/RTJ (lb/kg)
2	1.87	14.5	14.61	8.5	16.93	11.81	161/150
50	47.5	368	371	216	430	300	73/68
2 1/2	2.24	16.5	16.61	10	19.69	13.78	253/231
65	57	419	422	254	500	350	115/105
3	2.76	18.5	18.62	12	29.53	15.75	324/291
80	70	470	473	305	750	400	147/132
4	3.58	21.5	21.61	16	32.28	17.72	436/319
100	91	546	549	406	820	450	198/182
5	4.73	26.5	26.61	19	34.65	19.7	771/731
125	111	673	676	483	880	500	350/332
6	5.35	27.75	28	22	35.83	23.6	1123/1068
150	136	705	711	559	910	600	510/485
8	7	32.75	33.15	28	39.96	-	-
200	178	832	842	711	1015	-	-
10	8.74	39	39.41	34	40.75	-	-
250	222	991	1001	864	1035	-	-
12	10.35	44.5	45.12	39	53.15	-	-
300	263	1130	1146	991	1350	-	-
14	11.38	49.5	50.24	42	57.48	-	-
350	289	1259	1276	1067	1460	-	-
16	13	54.5	55.35	47	61	-	-
400	330	1384	1406	1194	1550	-	-
18	14.61	60.5	61.38	53	64.57	-	-
450	371	1537	1559	1346	1640	-	-
20	16.38	65.5	66.38	58	66.93	-	-
500	416	1664	1686	1473	1700	-	-

The dimension and weights are for reference only and subject to change without notice.

1. For more dimensional information, please contact our sales representative.
2. "W" on above schematic is the diameter for hand wheel, the one without dimension on the table above is defaulted by gear operation.

GLOBE VALVE

DIMENSIONS AND WEIGHTS (Pressure Seal Bonnet)

ASME CLASS 2500 (PN 420)

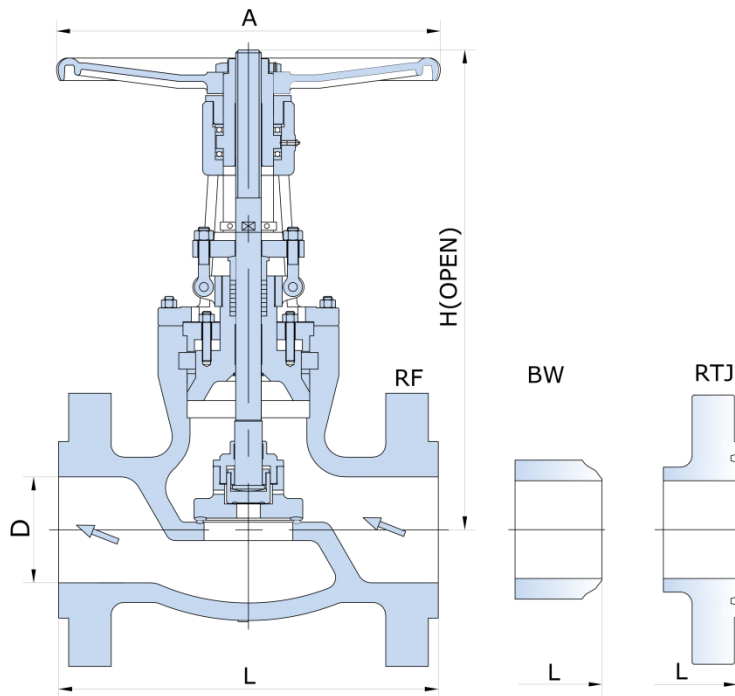

ASME CLASS 2500 (PN 420)

Size in/mm	D	L			H	W	Weight
		RF	RTJ	BW			RF/RTJ (lb/kg)
2	1.5	17.75	17.88	11	19.5	13.78	258/163
50	38	451	454	279	495	350	117/74
2 1/2	1.89	20.32	20.56	13	21.65	17.72	341/286
65	48	508	514	330	550	450	155/130
3	2.24	22.75	23	14.5	23.74	17.72	430/251
80	57	578	584	368	603	450	195/114
4	2.87	26.5	26.88	18	26.97	19.69	573/441
100	73	673	683	457	685	500	260/200
5	3.62	31.26	31.77	521	33.46	23.62	1674/1167
125	92	794	807	33	850	600	760/530
6	4.37	36	36.5	24	38.23	23.62	2737/1689
150	111	914	927	610	971	600	1238/767
8	5.75	40.25	40.88	30	43.31	-	-
200	146	1022	1038	762	1100	-	-
10	7.27	50	50.88	36	47.24	-	-
250	184	1270	1292	914	1200	-	-
12	8.62	56	56.88	41	60	-	-
300	219	1422	1444	1041	1524	-	-

The dimension and weights are for reference only and subject to change without notice.

1. For more dimensional information, please contact our sales representative.
2. "W" on above schematic is the diameter for hand wheel, the one without dimension on the table above is defaulted by gear operation.

GLOBE VALVE

VALVE FIGURE NUMBER

HOW TO ORDER

Nominal Size	Valve Type	Pressure Rating	End Conn.	Construction	Body Material	Trim Material	Seat	O-ring	Operation Mode
A	B	C	D	E	F	G	H	I	J
e.g. 0 8	G L	6	R	1	C 4	0 5	N	0	G

NPS 8 Class 600, Globe Valve, Straight pattern, Bolt bonnet, Raised Face, WCB body, Trim 5#, Non Renewable Seat, No O-ring, Gear Operated.

A Nominal Size

00 Special	02 2 (DN 50)	07 8 RB	19 20 RB	31 32 RB
F1 3/8 (DN 10)	R2 2 RB	08 8 (DN 200)	20 20 (DN 500)	32 32 (DN 800)
F2 1/2 (DN 15)	F6 2 1/2 (DN 65)	09 10 RB	21 22 RB	33 34 RB
0R 1/2 RB	3R 2 1/2 RB	10 10 (DN 250)	22 22 (DN 550)	34 34 (DN 850)
F3 3/4 (DN 20)	03 3 (DN 80)	11 12 RB	23 24 RB	35 36 RB
R0 3/4 RB	R3 3 RB	12 12 (DN 300)	24 24 (DN 600)	36 36 (DN 900)
01 1 (DN 25)	04 4 (DN 100)	13 14 RB	25 26 RB	37 38 RB
R1 1 RB	R4 4 RB	14 14 (DN 350)	26 26 (DN 650)	38 38 (DN 950)
F4 1 1/4 (DN 32)	05 5 (DN 125)	15 16 RB	27 28 RB	39 40 RB
1R 1 1/4 RB	R5 5 RB	16 16 (DN 400)	28 28 (DN 700)	40 40 (DN 1000)
F5 1 1/2 (DN 40)	06 6 (DN 150)	17 18 RB	29 30 RB	41 42 RB
2R 1 1/2 RB	R6 6 RB	18 18 (DN 450)	30 30 (DN 750)	... More as such

B Valve Type

GL Globe Valve

C Pressure Rating

0 Special	7 Class 2500
1 Class 150	9 Class 900
3 Class 300	8 Class 800
5 Class 1500	2 Class 125(PN16)
6 Class 600	4 Class 400(PN64)

D End Connection

X Special	B Butt-Weld (BW)
R RF Flanged	S Socket-Weld (SW)
J RTJ Flanged	
F FF Flanged	
T Threaded	

E Construction

GL
1 Straight pattern, Bolt bonnet
2 Straight pattern, Welded Bonnet
3 Straight pattern, Pressure Seal
4 Y- pattern, Bolt bonnet
5 Y- pattern, Welded Bonnet
6 Y- pattern, Pressure Seal

F Body Material

X0 Special	M9 A182 F22 CL 3	L5 A350 LF3	S6 A351 CF8M
C1 A105	Mo A217 WC9	L6 A352 LC3	S7 A182 F316L
C2 A216 WCA	E1 A182 F5	L7 A350 LF5	S8 A351 CF3M
C4 A216 WCB	E2 A217 C5	L8 A352 LCB	S9 A182 F347
C6 A216 WCC	E4 A217 C6	L9 A350 LF6	So A351 CF8C
M1 A182 F1	E5 A182 F9	LA A350 LF9	D1 A182 F51
M2 A217 WC1	E6 A217 C12	LB A352 LC9	D2 A995 4A
M3 A182 F2	E7 A182 F91	LD A352 LCC	D3 A182 F53
M4 A217 WC4	E8 A217 C12A	S1 A182 F304	D4 A995 5A
M5 A182 F12 CL 2	L1 A350 LF1	S2 A351 CF8	D5 A182 F55
M6 A217 WC5	L2 A352 LCA	S3 A182 F304L	D6 A995 6A
M7 A182 F11 CL 2	L3 A350 LF2	S4 A351 CF3	
M8 A217 WC6	L4 A352 LC2	S5 A182 F316	

G Trim Material

00 Special	08 13Cr/Stellite /13Cr	16 Stellite /Stellite /316	25 F53 /F53 /F53
01 13Cr/13Cr/13Cr	09 Monel/Monel /Monel	17 Stellite /Stellite /347	32 316L /Stellite /316L
02 304/304/304	10 316/316/316	18 Stellite /Stellite /Alloy 20	33 Stellite /Stellite /316L
03 310/310/310	11 Monel/Stellite/Monel	20 304L /304L /304L	34 304L /Stellite /304L
04 Hard 13Cr/Hard 13Cr/13Cr	12 316/Stellite/316	21 316L /316L /316L	35 Stellite /Stellite /304L
05 Stellite /Stellite/13Cr	13 Alloy 20/Alloy 20 /Alloy 20	22 321 /321 /321	
06 13Cr/Cu-Ni/13Cr	14 Alloy 20/Stellite /Alloy 20	23 F55 /F55 /F55	
07 13Cr/Hard 13Cr /13Cr	15 Stellite /Stellite /304	24 F51 /F51 /F51	

GLOBE VALVE

VALVE FIGURE NUMBER(CONT'D)

HOW TO ORDER

Nominal Size	Valve Type	Pressure Rating	End Conn.	Construction	Body Material	Trim Material	Seat	O-ring	Operation Mode
A	B	C	D	E	F	G	H	I	J
e.g. 0 6	G A	6	R	1	C 4	0 5	R	0	H

NPS 8 Class 600, Globe Valve, Straight pattern, Bolt bonnet, Raised Face, WCB body, Trim 5#, Non Renewable Seat, No O-ring, Gear Operated.

H Seat

- R** Renewable Metal
- N** Non Renewable Metal

I O-Ring

- o None

J Operation

- B** Bare Stem
- H** Handwheel
- G** Gear
- P** Pneumatic
- E** Electric
- C** Gear w/ Chain
- N** Pneumatic-Hydraulic
- O** Solid Handwheel
- V** Handwheel with locking device

HOW THE FIGURE NUMBER SYSTEM WORKS

Introduction. Figure number system uses a code consisting 14 digits of letters and numbers to represent the specification of a valve of certain specification. Among 14 digits, they are separated into 10 groups identified by letters from A to J. Each group represents a parameter of a valve, together they contain almost all the essential parameters of the valve.

Uses. Using the figure number system to generate a code is easy. Under each group, the code is shown on the left while on the right is the meaning of the code. Start by selecting a code from group A, through group J. If the specification of the valve is not listed, select the code for "Special ". The total length of the figure number shall be exactly 14 digits.

Cautions. It is advised that you have as detailed the specification as possible to generate a figure number, which means eliminating "Specials". If you don't have enough specification or information about the valve you are ordering, or you're not sure how to use the system to generate a figure number, contact one of our sales representatives for help.

Note: FBV reserves the right to make any modifications without notice.



Offshore



Pipeline



Onshore



Refinery



IMPORTANT NOTICE

- All dimensions in inches not listed in standards are converted from millimeters. Weights in lbs (pounds) are converted from kilograms.
- Data listed in the catalog, including dimensions, weights, specifications and other valve related data are intended to provide general information and guidance only.
- FBV Inc. assumes no responsibility for errors or inadequacy relevant to any information provided in this catalog. Any information provided in this catalog is subject to change without notice.



2121 Brittmoore Rd Suite 4000
Houston, TX 77043 USA

T 832-203-5459
F 832-203-5461

E sales@fbvalve.com

www.fbvalve.com

©FBV Inc. All rights reserved.