

SAMSON

**SAMSON** SED

IMAGE

VALVE TECHNOLOGY  
ONE STEP AHEAD

SMART IN FLOW CONTROL.

# SED FLOW CONTROL COMPANY

SED is an internationally operating company, leading in the development, production and worldwide sales of sophisticated valve technologies.

## **YOUR PARTNER FOR AUTOMATED PROCESS TECHNOLOGY EQUIPMENT FOR CLOSING, DOSING, CONTROL AND REGULATION**

SED FLOW CONTROL was established over 30 years ago with the mission to provide high quality products for the life science and industrial market place.

A clearly defined range of products, our flexibility and our proximity to the clients are factors of considerable importance to our customers.

Our long term strategy and clear objectives keep our employees highly motivated. Their identification with the company and production process leads to high quality and proven reliability of our products.

Product management, engineering, sales, and all the other departments are pleased to work with our customer`s challenges. Either it is a big volume order, a short delivery time, or just an opportunity to find the most efficient process valve solution, SED is ready to take the challenge. In addition, the advantage of belonging to a solid industrial group as an autonomous and compact activity is fully realized through their combined synergy. This organizational structure provides financial stability and security for our customers and creates the best conditions for the evolution of the business.



# SED FLOW CONTROL PRODUCT PORTFOLIO

Many years of experience in all process applications and continuous research and development guarantee the highest quality and reliability of our products.

## SOPHISTICATED PRODUCTS WITH ATTRACTIVE FEATURES

SED is specialized in the development and manufacturing of diaphragm valves, seat valves and variable area flowmeters. A comprehensive range of control equipment and accessories completes the product portfolio. Valve bodies and actuation components are manufactured utilizing the highest grade of metal and plastic, allowing the product line to cover a large variety of demanding process applications.

### Product groups

- Metal Diaphragm Valve Aseptic
- Metal Diaphragm Valve Industrial
- Plastic Diaphragm Valve
- Metal Seat Valve
- Variable Area Flowmeter
- Monitoring and Control Equipment
  - EP Positioners
  - Electrical Limit Switches also on request with Integrated Pilot Valves; ASI; ATEX and Others
  - Manual Adjustments
  - Optical Visualizations
  - Pilot Valves





## APPLICATIONS

### ▪ Pharma-, Biotech-, Cosmetic-, Food-, Dairy and Beverage Industry

Fermentation  
Fragmentation  
Purified Water  
Mixing  
Aseptic Filling  
Freeze-Drying  
Steam Sterilization and Cleaning  
Media Supply  
Washing Equipment

Steam Production and Distribution  
Autoclaving

### ▪ Chemical Industry

Water Treatment  
Liquid Transportation  
Acid Filling

### ▪ Dye Industry

Liquid Transportation  
Mixing  
Water Treatment

### ▪ Power Station

Water Treatment and Distribution

### ▪ Petrochemical Industry

Water Treatment and Distribution

### ▪ Steel Works

Water Treatment and Distribution  
Cooling Water  
Pickling Lines

### ▪ Paper Industry

Water Treatment and Distribution

# SED FLOW CONTROL DIAPHRAGM VALVES FOR ASEPTIC APPLICATIONS

Take advantage of SED sophisticated aseptic diaphragm valves. Long experience in many installed bases confirms the reliability of our products and the benefits of our advanced design. SED valve bodies as standard are manufactured of the material 1.4435/316L ASME BPE and according to EN 10204 inspection certificate 3.1 Material test report (MTR). All valve bodies contain a clear identification with the heat number for traceability. SED offers three series of manually and pneumatically operated aseptic diaphragm valves, named as STERIPUR, KMA and KMD. The selection of each is influenced by different criteria, i.e. application, technical specification, process system and plant design, available space and last but not least the TCO.

**STERIPUR Series** are manually or pneumatically operated with stainless steel high performance piston actuator. Compact design, the outside diameter of the actuator is the same size as the bonnet flange, provides advantages in multiport bodies and manifold valve assemblies. Bottom entry steel bolting minimizes crevices, corners and loose parts during maintenance

**KMD Series** are manually or pneumatically operated with high temperature resistant plastic and high cycle performing piston actuator. Compact and light design and reduced heat conduction protects against burns and high energy loss. Bottom entry steel bolting minimizes crevices, corners and loose parts during maintenance.

---

Our passion is the diaphragm valve and providing you the best product for your application.

---

**KMA Series** are either manually operated with stainless steel bonnet and plastic hand-wheel or pneumatically operated with stainless steel distance piece with high cycle plastic actuation.

**Angle Seat Valves** are a complementary product in the aseptic application with stainless steel body and same materials as diaphragm valves. The design may be manually or pneumatically operated as open and close or as regulating valve with gland packing or bellow. An attractive range in the SED product portfolio. The major application is in steam production and distribution.



# SED FLOW CONTROL DIAPHRAGM VALVE SOLUTIONS

## MULTIPOINT VALVES

With the know-how and the capabilities of SED the efficient customized multipoint valve solution achieve a different focus with our customer.

Your challenge is our challenge, just let us know. A multipoint valve consists of a valve body machined from a solid block with several tube ends and valve actuation 1 to 20 or even more. The specification of multipoint valves in the process industry becomes more and more important. The reason is found in optimizing the process. The ideal benefit for you, our customer, is achieved through active and cooperative teamwork of both parties during the design and specification of the valves. This refers especially to the process requirements dictated by the P&ID's for proper flow direction, drainability and installation restraints.

Compact design and smaller envelope dimension together with SED actuations reinforces the advantages of multipoint designs

- Customer specific design
- Optimized drainability
- Minimized dead leg
- Reduces surface contact, hold up volume and cross contamination
- Reduction of connections, fittings, welds in the system
- Reduces validation and validation documentation requirements

The application of multipoint block valves is mainly for the distribution, point of use, sampling, diverting, mixing, bypass, drain and process sterilization.

---

SED not only supplies valves, it also supports and leads its customers towards a more efficient process solution.

---

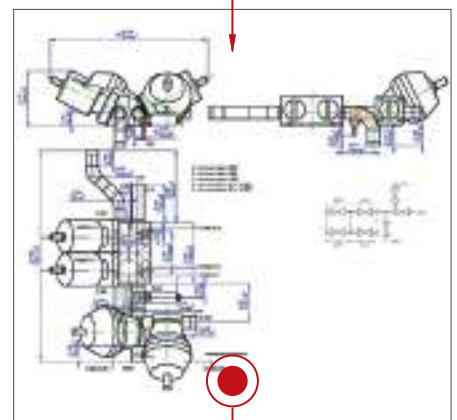
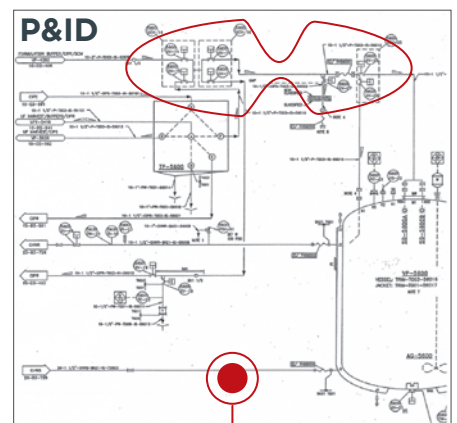

# SED FLOW CONTROL

## CDSA SEALING CONCEPT

### ADVANTAGES CDSA

The first introduction of the SED CDSA sealing concept was on a specific application before year 2000. For several years this concept has been realized in all SED aseptic diaphragm valves. Nowadays, it is a well-recognized and sophisticated sealing concept.

The unique design of the actuator and the diaphragm reduces or eliminates product entrapments in the point beyond the radius of the weir and around the body bonnet flange.

The CDSA sealing concept is achieved by the compressor being guided by the interior circular actuator lower housing and a flat diaphragm and a rip on the body flange providing a circumferential defined sealing angle at 360°.

The effects of this design have the following advantages:

- Internal cleaning is more efficient and has been tested and qualified by EHEDG Document No. 8

### CONVENTIONAL DESIGN

The conventional design in the market does not provide this feature because the compressor is typically designed with fingers that extend the internal diameter of the body flange and the flat machined

Wherever sterility, cleanability or cross-contamination has a meaning the SED CDSA sealing concept is the solution.

- Product entrapment reduced or eliminated on the body bonnet flange
- Reduced cleaning time SIP System
- Reduced use of chemicals and solutions in CIP systems
- Improves valve drain ability
- Better sealing performance and evenly distributed closing force
- Diaphragm lifetime is extended.

body flange requires a circumferential rip on the diaphragm. The risk of contamination is much higher and cleaning is less efficient.

### CDSA SEALING CONCEPT

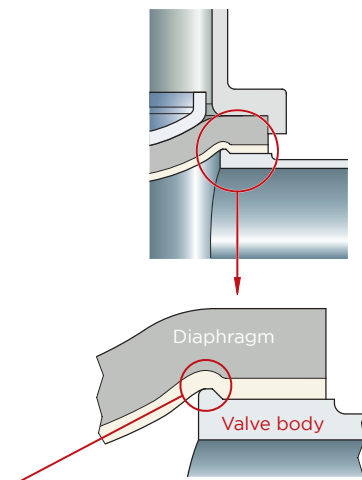

Product entrapment eliminated

### CONVENTIONAL SEALING CONCEPT

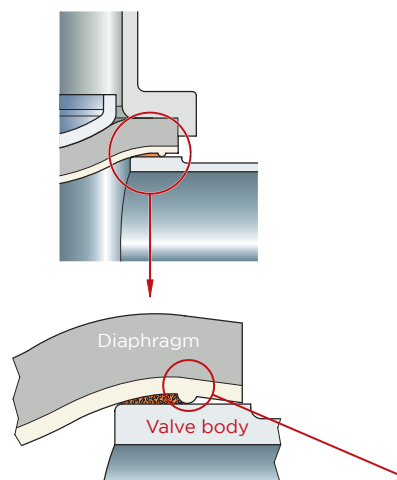

Product entrapment and almost impossible to clean

# SED FLOW CONTROL INDUSTRIAL DIAPHRAGM VALVES, VARIABLE AREA FLOWMETERS AND ANGLE SEAT VALVES

## WIDE RANGE OF PRODUCTS

**Metal Diaphragm Valves** are available DN10 to DN200 or bigger. The standard flanges are either DIN PN16 or ANSI 150. As threaded socket the sizes are from DN10 to DN 80. The actuation is manually or pneumatically operated. According to the valve size the design is compact and light. Materials in different metal, lined or unlined, as end connection flanged or threaded socket.

## PRODUCTS APPLIED IN DIFFERENT INDUSTRIES FOR HANDLING LIQUIDS, GASEOUS AND CHEMICALS ALSO WITH SOLID PARTICLES

**Plastic Diaphragm Valves** cover the sizes from DN10 to DN100, manually or pneumatically operated. The connections are threaded, true union, spigot end or flanged. Plastic material is available in PVC, CPVC, PP, PVDF and ABS.

**Angle Seat Valves** are available from DN 4 to DN80, manually or pneumatically operated. Several different actuator sizes are available to be adjusted according to specified working pressure. The material

is stainless steel and the connection is either tube end or threaded socket.

### Variable Area Flow Meter (VAF)

It is one of the widest ranges in the market with measurements based on water of 1,5l/h to 50m<sup>3</sup>/h. Tube materials PVC, PA or PSU. The VAF can be equipped with floater in plastic or stainless steel. And for control with Max- Min Contacts or for continuous reading with a Measurement Chain.





# SED FLOW CONTROL VALVE MONITORING, ADJUSTMENT AND CONTROL

## **Electropneumatic Valve Positioner ECOCENT 024.16.7**

Compact positioner for integrated mounting on pneumatically operated process valves. Remote setpoint adjustment via a 4-20 mA signal. A contact-free continuous sensor measures the position of the valve spindle. Simple installation through automatic tune function and setting through DIP-switch. The valve position indication is shown through LED components. As an option an analogue position feedback can be integrated.

## **Control Head Switch 024.63-89**

The control head for linear movements provides signals both open and closed positions of the valve and includes optionally an integral solenoid valve for a direct air line connection in the actuator. The integral solenoid valve has a high flowrate and is suitable for pneumatically

operated valves up to DN100. The control head circumferential catch the eye visual indication, is also available with ASI Bus and provides a number of further attractive features.

## **Stroke Seal Adjuster 024.14**

The stroke seal adjuster is one of the possible mechanical valve adjusters designed with stainless steel hand-wheel. It is to set manually the open position of the valve

---

An adapted coordinated product offering of accessories and control equipment ensures highest reliability in the process.

---

## **Contact Free Limit Switch 024.50**

Limit switches are used to control, monitor and view the position of the valve or to activate other system components. SED has a contact free robust limit switch with magnet field measurement technology. Apart from lifetime and among other features the limit switch is hermetically sealed and available in high performing plastic or stainless steel housing. The equipment is also approved for ATEX II.

and it is compact, nicely integrated in the valve actuation and easy to operate.

## **3/2 Way Plastic Pilot Valve 602**

The solenoid valve is an electromagnetic, direct actuated pilot valve to control pneumatically operated valve actuators. It is a very compact pilot valve suitable for easy direct mounting with hollow screw and as manifold assembly.



# SED FLOW CONTROL YOUR PARTNER FOR ADVANCED VALVE TECHNOLOGIES

## PRODUCTION

The company has installed the most modern machinery and individual production facilities which are fully adapted to current market requirements.

Specifically:

- The 3D-Cad –Cam network connects all the CAD workstations with the CNC machining facilities, bringing our products from conception to development.
- Injection molding manufacturing, special injection molding machines, and tools adapted to high performance plastics and specific processes.

- Assembly in room facilities with clean environment ultrasonic clean washing including other automated assembly capabilities.

- Programmable welding machine and polishing work stations for aseptic diaphragm valves in order to guarantee the greatest flexibility and quality.

---

State-of-the-art production facilities allows competitive manufacturing and reliable customer service.

---

- Work stations which are ergonomically designed for the health and safety of our employees.

Our employees training and experience over the years have developed an attitude which is characterized by flexibility and meeting our customer's need.



# SED FLOW CONTROL

## THE FUNDAMENTAL AREAS OF OUR QUALITY POLICY

### Products and Services:

An accelerated implementation of customized solutions is achieved with personal conversations and direct customer input. This is supported by the specialization of SED through development and production areas with efficient experience and extensive training requirements.

### Suppliers:

The quality of our products is directly dependent on the performance of our suppliers. Through a supplier qualification process, continuous assessments are performed, documented and form the basis of a close customer-supplier-relationship.

### Work Sequences:

For each individual step of the manufacturing process the motto "My colleague is my customer" applies. This means that everybody has to handle their production responsibility in a way that the internal customer is satisfied and that their best work is possible.

### Customers:

Our customer is our employer and should see their visions and wishes realized. This means that our goal is to work together with our customers to develop solutions and implement these solutions with cost effective results.

### Employees:

The greatest asset of our company is our employees. Embracing quality is not the result of an individual but the outcome of successful teamwork. The ability to develop new ideas, to take on responsibility and to show initiative and creativity brings us continuous development and improvement. Each level of the company believes in our quality and growth philosophy and this is reinforced with continued education.

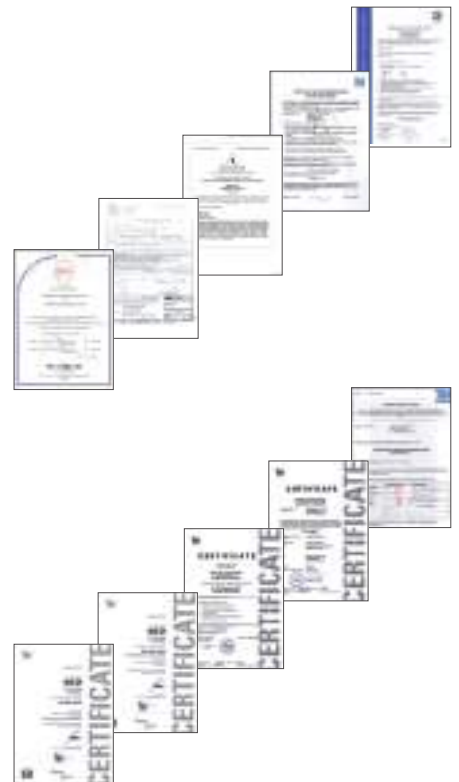

Material analysis				
Übersichtsbilanz 31.04.2012 02:22				
Zur Info				
E	Min	%	Max	+/-
Fe	68.000	73.233	75.000	0.502
Cr	17.000	17.874	18.000	0.294
Ni	8.000	8.200	10.000	0.200
Mn	0.000	0.000	2.000	0.178
B	0.150	0.150	0.400	0.040
Ca		0.209		0.038
Si	0.000	0.000	1.000	0.108
Al		0.209		0.170
Mo	0.000	0.000	0.400	0.010
Ti	0.000	0.000	0.010	0.049



SAMSON

SAMSON SED

IMAGE

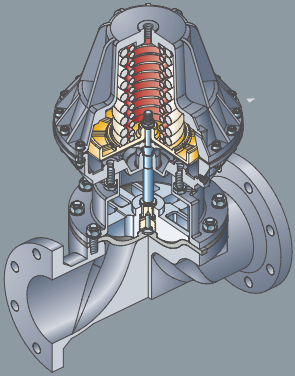

SED Flow Control GmbH  
Am Schafbaum 2 · 74906 Bad Rappenau  
Telefon: +49 7264 921 0 · Telefax: +49 7264 921 21  
E-Mail: [info@sed-flowcontrol.com](mailto:info@sed-flowcontrol.com) · Internet: [www.sed-flowcontrol.com](http://www.sed-flowcontrol.com)

SMART IN FLOW CONTROL.