

# TEXSTEAM D Series Plug Valves

Low-maintenance, bubble-tight sealing for severe service applications

TECHNOLOGY

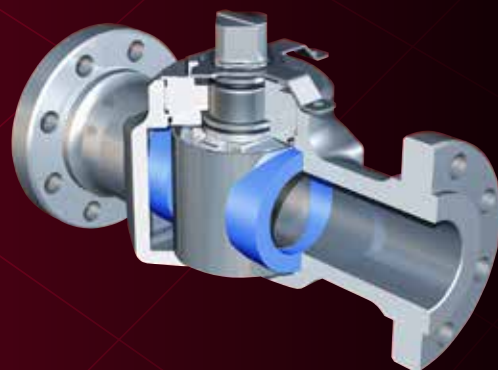



# Table of Contents

## TEXSTEAM D SERIES PLUG VALVES

Features and Benefits.....	2
Specifications and Materials.....	3
Applications.....	4
Flanged End Dimensions.....	5
Threaded End Dimensions.....	6
Flow Coefficients – Torque and Wrench Data.....	7
CAMSERV Services for Valves and Actuation.....	8
Trademark Information.....	9

# TEXSTEAM D Series Plug Valves

## FEATURES AND BENEFITS

For severe service conditions – H<sub>2</sub>S, CO<sub>2</sub> and abrasive applications – Cameron’s TEXSTEAM™ D Series plug valves are ideal.

- Bubble-tight sealing
- Soft seats resistant to pitting or scratching
- Round ports reduce fluid turbulence and pressure drop
- No lubrication required for operation or sealing, reducing maintenance costs
- Compact and lightweight design as a result of no lubrication system
- Top-entry in-line repair allows seat/plug removal/replacement without removing the body from the line
- Wide temperature range for severe service conditions
- Ample internal clearance prevents solid buildup from interfering with the free movement of the plug in water, cementing and drilling mud operations
- Position indicator and locking plate for port position indication and tamper resistance
- Quarter-turn operation with cast integral stops ensures quick positive control
- Square stem is robust and requires no special wrench for operation (wrenches are available as an option)
- Repair kits are available for quick and economical repair with reduced downtime
- Durability from wear and shock-resistant components

### MOLDED SEATS – RESILIENT SEALS

Specially compounded glass-filled epoxy composition with PC Buna-N is used (FKM optional).

### SELF-ALIGNING PLUG

Internally balanced and separated from the stem, the plug is in complete alignment at all times and is free to align itself to the downstream seat face in the closed positions. It is self-compensating for normal wear. All plugs are electroless nickel-plated for corrosion and wear resistance. 316 stainless steel plug and stem are available as an option.

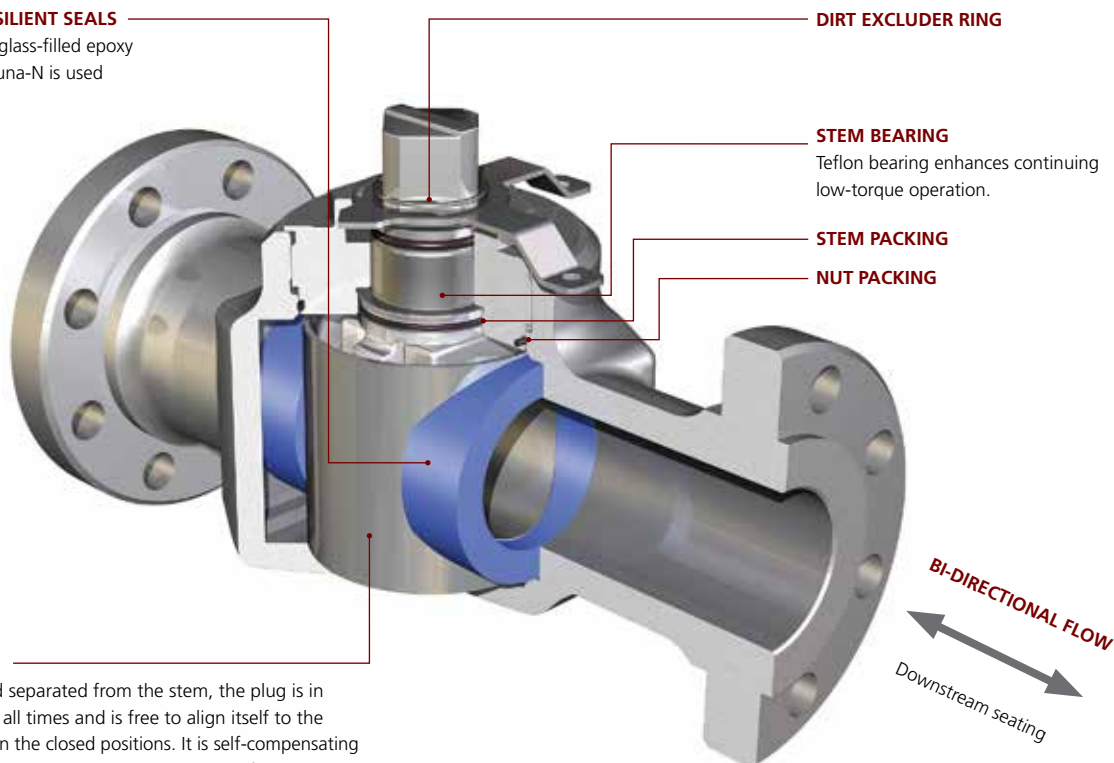

## SPECIFICATIONS AND MATERIALS

### Sizes

- 1" reduced port through 4" reduced port
- 2" and 3" available in reduced port and full port

### Pressures

- Flanged (RF, RJ) are available in ASME Class 150, 300 and 600
- Threaded, butt weld and socket weld are available in 1" valves for 285 psi through 3000 psi and 2" through 4" valves for 285 psi through 2000 psi

### Temperature Ranges

- PC Buna trim for -20° F to 200° F (-29° C to 93° C)
- FKM trim available for -10° F to 400° F (-24° C to 204° C)

### Body Materials

- ASTM WCC carbon steel
- 40,000 tensile (min.); 36,000 yield (min.); and 22% elongation in 2" (min.)

### Seat Materials

- Soft, PC Buna-N\* injection-molded seats allow TEXSTEAM D Series valves to be effective (\*FKM optional)
- Resistant to pitting or scratching under tough service conditions

### Standards

- Meets NACE MR0175
- Built and tested to ASME B16.34



### Materials List

Item	No. Required	Name of Part	
1	1	Body	ASTM A216 WCC Carbon Steel
2	2	Seat	PC Buna-N (FKM Optional)
3	1	Plug	ASTM A395 Nickel-plated
4	1	Stem Nut	ASTM A216 WCB
5	1	Stem	ASTM A395 Ductile Iron
6	1	Stem Bearing	Teflon-filled Nylon
7	1	O-ring	70 Durometer PC Buna-N (FKM Optional)
8	1	O-ring	70 Durometer PC Buna-N (FKM Optional)
9	1	O-ring	70 Durometer PC Buna-N (FKM Optional)
10	1	Snap Ring	Carbon Steel
11	1	Locking Plate	Carbon Steel Cadmium-plated



## APPLICATIONS

TEXSTEAM D Series plug valves feature a time-tested design that has provided long service life in tough oilfield conditions worldwide since 1965.

- Tank batteries
- Oil, gas and water flowlines
- Gas systems
- Christmas tree service
- Saltwater injection
- Vacuum
- Pneumatic or electric actuators
- Production manifolds
- Compressed air-gas
- Metering stations
- Loading racks
- Underground gas storage
- LPG service
- Compressor installations
- Drilling fluids
- Slurry service\*

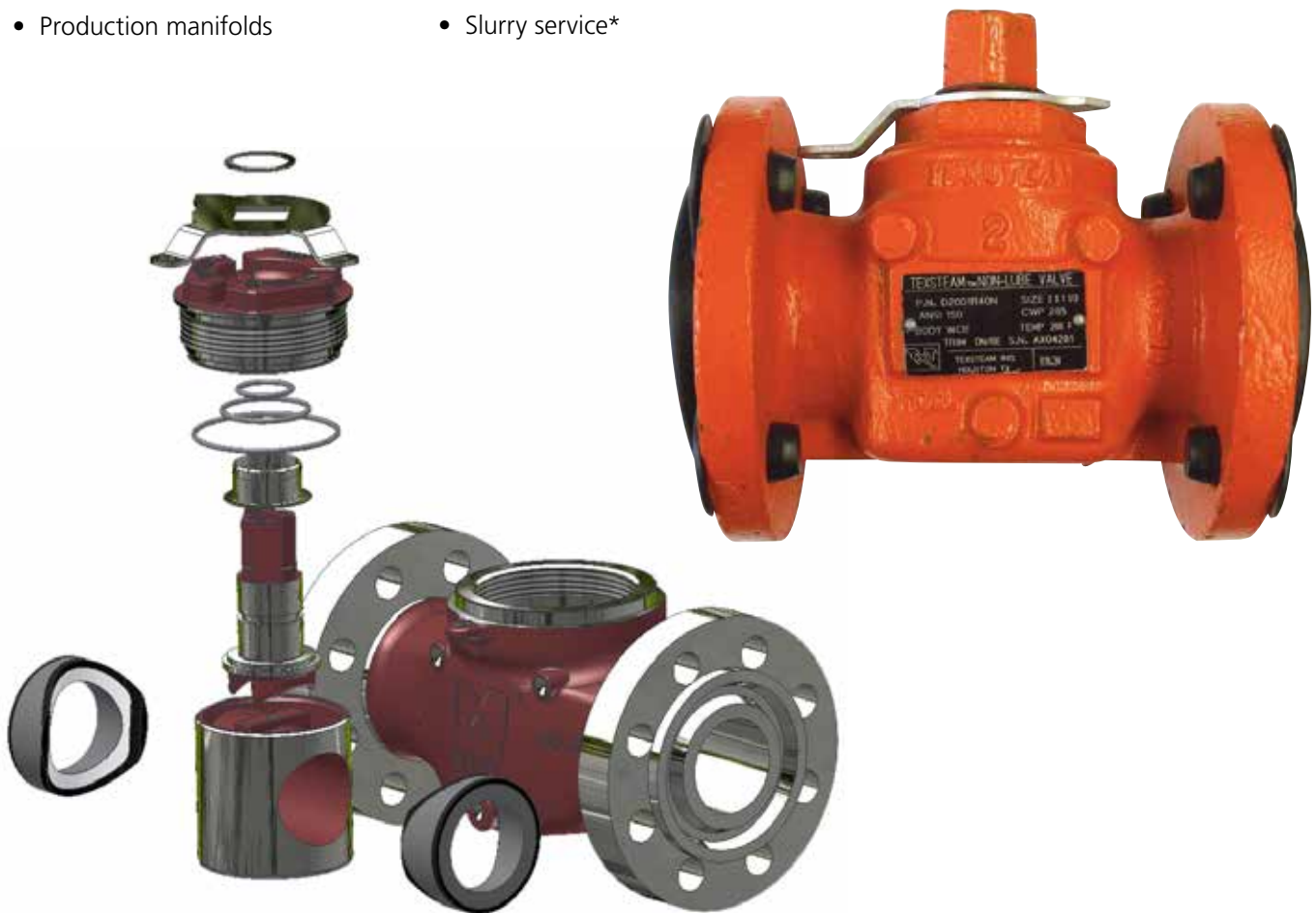

\*Independent laboratory tests results using both water and low-pressure air in a 2% sand slurry mix confirmed bubble-tight sealing after 50 hours of flow testing and 500 operational cycles.

## FLANGED END DIMENSIONS

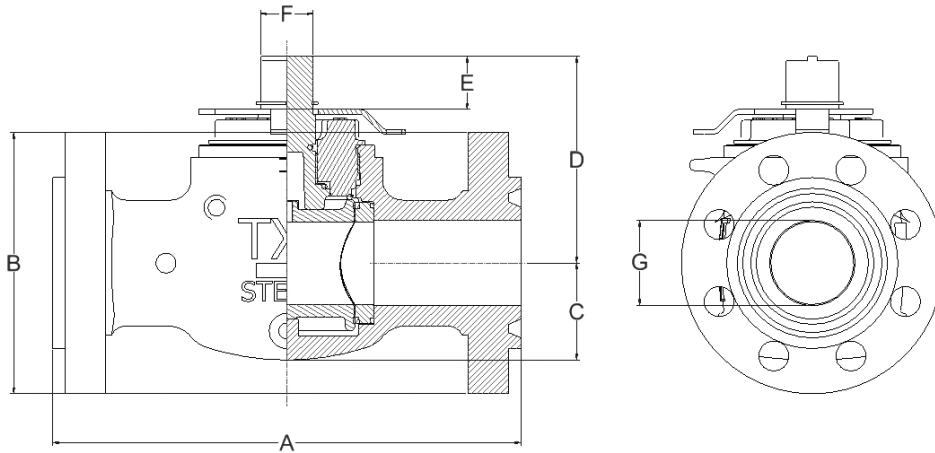

### Flanged End Dimensions

Valve Size (in.)	Model Number	ASME Class	Working Pressure	Port Opening	Dimension (inches)							Weight (lb)
					A	B	C	D	E	F	G	
1	6104	150	285 psi	Reduced	5-1/2	4-1/4	2-1/8	3-1/8	1	1-1/8	15/16	9.1
	6304	300	740 psi	Reduced	6-1/4	4-7/8	2-7/16	3-1/8	1	1-1/8	15/16	12.1
	6604	600	1480 psi	Reduced	8-1/2	4-7/8	2-7/16	3-1/8	1	1-1/8	15/16	12.7
2	6104	150	285 psi	Reduced	7	6	3	4-1/8	1-3/8	1-5/16	1-5/8	22.5
	6106	150	285 psi	Full	10-1/2	6	3	4-5/8	1	1-5/16	2-5/8	36.0
	6304	300	740 psi	Reduced	8-1/2	6-1/2	3-1/4	4-1/8	1-3/8	1-5/16	1-5/8	26.5
	6306	300	740 psi	Full	11-1/8	6-1/2	3-1/4	4-5/8	1	1-5/16	2-1/8	38.0
	6604	600	1480 psi	Reduced	11-1/2	6-1/2	3-1/4	4-1/8	1-3/8	1-5/16	1-5/8	39.0
	6606	600	1480 psi	Full	11-1/2	6-1/2	3-1/4	4-5/8	1	1-5/16	2-1/8	41.0
3	6104	150	285 psi	Reduced	8	7-1/2	3-3/4	4-9/16	1	1-5/16	2-1/8	41.0
	6106	150	285 psi	Full	13-1/2	7-1/2	3-3/4	6-7/16	1-3/4	2-3/16	3-1/8	70.0
	6304	300	740 psi	Reduced	11-1/8	8-1/4	4-1/8	4-9/16	1	1-5/16	2-1/8	45.0
	6306	300	740 psi	Full	15-1/4	8-1/4	4-1/8	6-7/16	1-3/4	2-3/16	3-1/8	84.0
	6604	600	1480 psi	Reduced	14	8-1/4	4-1/8	4-9/16	1	1-5/16	2-1/8	67.0
	6606	600	1480 psi	Full	17-1/2	8-1/4	4-1/8	6-7/16	1-3/4	2-3/16	3-1/8	124.0
4	6104	150	285 psi	Reduced	9	9	4-1/2	6-7/16	1-3/4	2-3/16	3-1/8	75.0
	6304	300	740 psi	Reduced	12	10	5	6-7/16	1-3/4	2-3/16	3-1/8	105.0
	6604	600	1480 psi	Reduced	17	10-3/4	5-3/8	6-7/16	1-3/4	2-3/16	3-1/8	131.0

When ordering, specify "RF" for raised face or "RJ" for ring joint flange.

Note: All flange valve lengths given are RF. Add 1/8" to length for RJ ASME Class 600.

## THREADED END DIMENSIONS

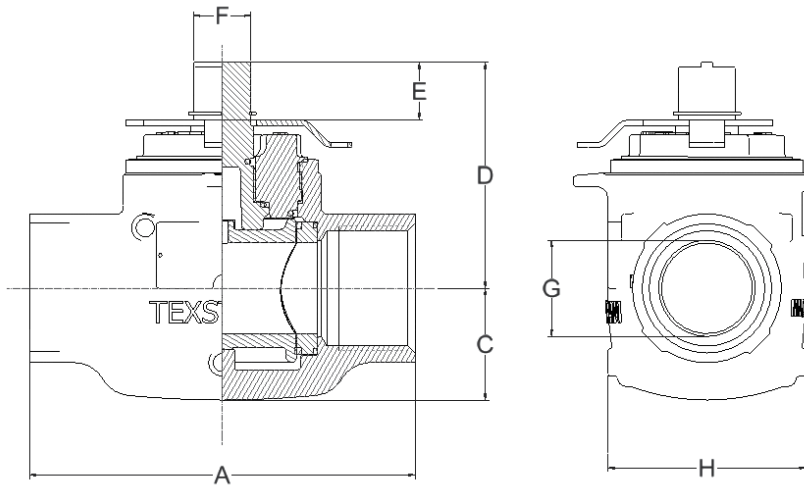

### Threaded End Dimensions

Valve Size (in.)	Model Number	Working Pressure	Port Opening	Dimension (inches)							Weight (lb)
				A	H	C	D	E	F	G	
1	204	285 psi	Reduced	5-1/8	2-3/8	1-3/8	3-1/8	1	1-1/8	15/16	5.5
	1004	1000 psi	Reduced	5-1/8	2-3/8	1-3/8	3-1/8	1	1-1/8	15/16	5.5
	1504	1500 psi	Reduced	5-1/8	2-3/8	1-3/8	3-1/8	1	1-1/8	15/16	5.5
	2004	2000 psi	Reduced	5-1/8	2-3/8	1-3/8	3-1/8	1	1-1/8	15/16	5.5
	3004*	3000 psi	Reduced	5-1/8	2-3/8	1-3/8	3-1/8	1	1-1/8	15/16	5.5
2	204	285 psi	Reduced	7-1/4	4-1/32	1-3/8	4-5/16	1-3/8	1-5/16	1-5/8	12.5
	206	285 psi	Full	8-5/8	4-1/2	2-3/16	4-5/8	1	1-5/16	2-1/8	24.0
	1004*	1000 psi	Reduced	7-1/4	4-1/32	1-7/8	4-5/16	1-3/8	1-5/16	1-5/8	12.5
	1006*	1000 psi	Full	8-5/8	4-1/2	2-3/16	4-5/8	1	1-5/16	2-1/8	24.0
	1504*	1500 psi	Reduced	7-1/4	4-1/32	1-7/8	4-5/16	1-3/8	1-5/16	1-5/8	12.5
	1506*	1500 psi	Full	8-5/8	4-1/2	2-3/16	4-5/8	1	1-5/16	2-1/8	24.0
	2004*	2000 psi	Reduced	7-1/4	4-1/32	1-7/8	4-5/16	1-3/8	1-5/16	1-5/8	12.5
2006*	2000 psi	Full	8-5/8	4-1/2	2-3/16	4-5/8	1	1-5/16	2-1/8	24.0	
3	204	285 psi	Reduced	9-9/16	5	2-7/16	4-9/16	1	1-5/16	2-1/8	25.0
	206	285 psi	Full	10-7/8	6-3/4	3-1/4	6-7/16	1-3/4	2-3/16	3-1/8	64.0
	1004	1000 psi	Reduced	9-9/16	5	2-7/16	4-9/16	1	1-5/16	2-1/8	25.0
	1006*	1000 psi	Full	10-7/8	6-3/4	3-1/4	6-7/16	1-3/4	2-3/16	3-1/8	64.0
	1504*	1500 psi	Reduced	9-9/16	5	2-7/16	4-9/16	1	1-5/16	2-1/8	25.0
	1506*	1500 psi	Full	10-7/8	6-3/4	3-1/4	6-7/16	1-3/4	2-3/16	3-1/8	64.0
	2004*	2000 psi	Reduced	9-9/16	5	2-7/16	4-9/16	1	1-5/16	2-1/8	25.0
2006*	2000 psi	Full	10-7/8	6-3/4	3-1/4	6-7/16	1-3/4	2-3/16	3-1/8	64.0	
4	204	285 psi	Reduced	12-1/8	6-3/4	3-3/8	6-7/16	1-3/4	2-3/16	3-1/8	69.0
	1004*	1000 psi	Reduced	12-1/8	6-3/4	3-3/8	6-7/16	1-3/4	2-3/16	3-1/8	69.0
	1504*	1500 psi	Reduced	12-1/8	6-3/4	3-3/8	6-7/16	1-3/4	2-3/16	3-1/8	69.0
	2004*	2000 psi	Reduced	12-1/8	6-3/4	3-3/8	6-7/16	1-3/4	2-3/16	3-1/8	69.0

\* When ordering, specify "SW" for socket weld or "BW" for butt weld. Specify pipe schedule for "BW" ends.



## FLOW COEFFICIENTS – TORQUE AND WRENCH DATA

### Full Opening Valves Exceed Nominal Pipe Size

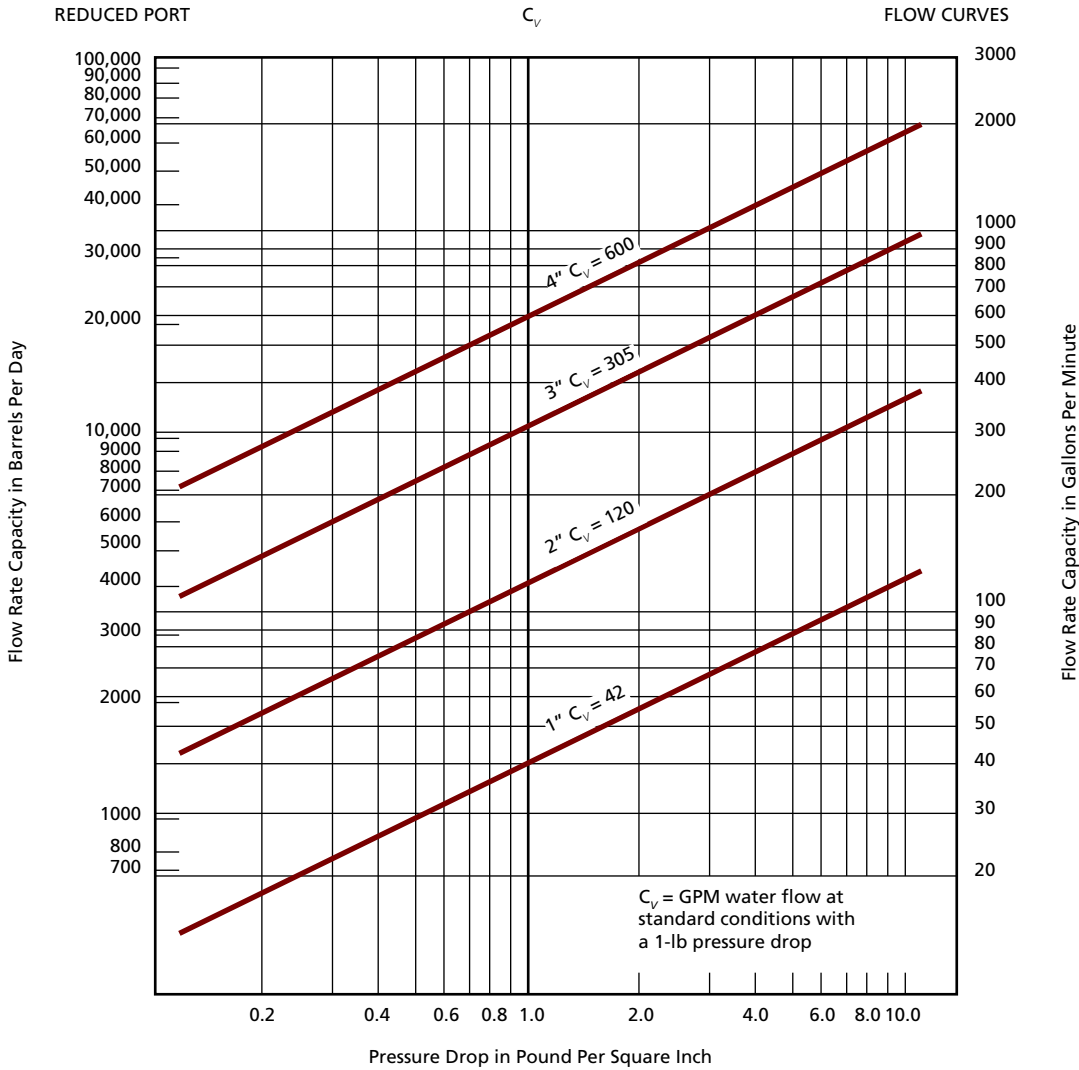

### Torque (ft-lb)

Pressure (psi)	Inches					
	1 RP	2 RP	2 FP	3 RP	3 FP	4 RP
0	6	10	12	12	15	15
200	8	15	27	27	34	34
500	13	25	36	36	48	48
1000	18	31	48	48	60	60
1500	20	37	60	60	90	90
2000	26	42	65	65	105	105
2500	28	-	-	-	-	-
3000	34	-	-	-	-	-

### Wrench Data

Valve Size (in.)	Part Number
1 RP	9D-GA1382
2 RP	9D-GB 0445
2 FP	9D-GB 0445
3 RP	9D-GB 0445
3 FP	9D-GB 0879
4 RP	9D-GB 0879

## CAMSERV™ Services for Valves and Actuation

WE BUILD IT. WE BACK IT.



### Global Network and Local Support

Cameron is well-positioned to deliver total aftermarket support, quickly and efficiently, with unmatched OEM expertise. Our highly skilled engineers and technicians are available around the clock, seven days a week to respond to customer queries, troubleshoot problems and offer reliable solutions.

### Easily Accessible Parts and Spare Valves

- OEM spare valves, actuators and parts (including non-Cameron brands)
- Handling, storage, packaging and delivery
- Dedicated stocking program

### Comprehensive Aftermarket Services Portfolio

- Parts and spare valves
- Repair
- Field services
- Preventative maintenance
- Equipment testing and diagnostics
- Remanufacturing
- Asset preservation
- Customer property management
- Training and recertification services
- Warranty

### Customized Total Valve Care™ (TVC) Programs

Customized asset management plans that optimize uptime, availability and dedicated services.

- Engineering consultancy
- Site management
- Flange management
- Startup and commissioning
- Spare parts and asset management
- Operational support



# Trademark Information

TEXSTEAM is a registered trademark which is owned by Cameron.

This document contains references to registered trademarks or product designations, which are not owned by Cameron.

Trademark	Owner
Teflon	E.I. DuPont De Nemours & Company

3250 Briarpark Drive, Suite 300  
Houston, TX 77042  
USA  
Toll Free 1.800.323.9160

Learn more about TEXSTEAM at:  
[www.c-a-m.com/valves](http://www.c-a-m.com/valves)



**HSE Policy Statement**

At Cameron, we are committed ethically, financially and personally to a working environment where no one gets hurt and nothing gets harmed.

# TEXSTEAM™ Super G Plug Valves

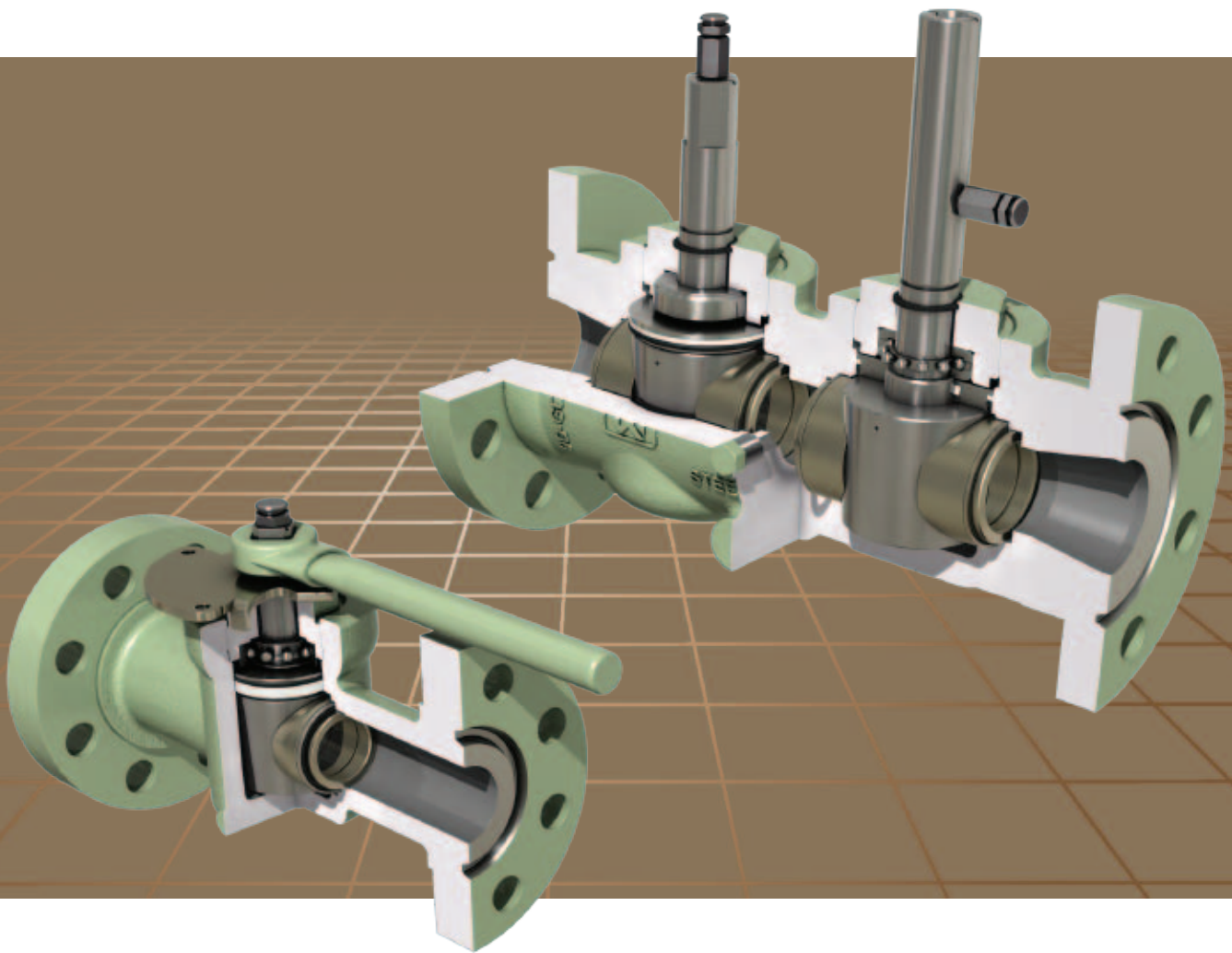

**TEXSTEAM™**





## TABLE OF CONTENTS

### TEXSTEAM SUPER G PLUG VALVES

Introduction.....	4
Design Standards.....	5
Parts List.....	6
Accessories and Repair Kits.....	7
Reduced Port Dimensions and Weights.....	8
Full Port Dimensions and Weights.....	9
Comparison Chart and Average Operating Torque.....	10
Flow Coefficients $C_v$ .....	11
Single Body/Dual Plug Double Block-and-Bleed.....	12
Double Block-and-Bleed Dimensions and Weights.....	13
Aftermarket Services.....	14
Trademark Information.....	15



Hammond, LA

Cameron is a leading provider of flow equipment products, systems and services to worldwide oil, gas and process industries. From our Valves & Measurement business segment, we offer products primarily used to control, direct and measure the flow of oil and gas as it is moved from individual wellheads through flowlines, gathering lines and transmission systems to refineries, petrochemical plants and industrial centers for processing.

Cameron is a complete systems solution supplier, delivering new levels of efficiency and cost savings to our customers due to our full in-house capability to provide controls engineering and manufacturing together with choke, actuation and automation expertise, as well as project management, system engineering, operability and training.

Our TEXSTEAM plug valves have a long history of reliability in tough service conditions such as H<sub>2</sub>S, CO<sub>2</sub> and abrasive or severe service applications. TEXSTEAM valves are designed for high corrosion resistance, bubble-tight sealing, high wear and high impact resistance.



## TEXSTEAM SUPER G PLUG VALVES

### DESIGN STANDARDS

The TEXSTEAM super G's reputation for tight shut-off and long service life has made it a preferred valve for manifold and production services in erosive environments.

Super G valves conform to the latest edition of the following industry specifications as applicable:

- B1.20.1 - Pipe threads, general purpose
- B16.5 - Pipe flanges and flange fittings
- B16.10 - Face-to-face and end-to-end dimensions of valves
- B16.25 - Butt welding ends
- B16.34 - Valves-flanged, threaded and welding end
- API - American Petroleum Institute
- 6D - Specification for pipeline valves – monogram available
- 6FA - Fire-test for valves
- MSS - Manufacture's standardization society of the valve and fittings industry
- SP-6 - Standard finishes for contact faces of pipe flanges and connecting end flanges of valves and fittings
- SP-25 - Standard marking system for valves, fittings, flanges and unions
- SP-55 - Quality standard for steel castings for valves, flanges, fittings and other piping components (visual methods)
- NACE MR0175 - Sulfide stress cracking resistant metallic materials for oil field equipment
- Equipped with a lock open/close position indicator

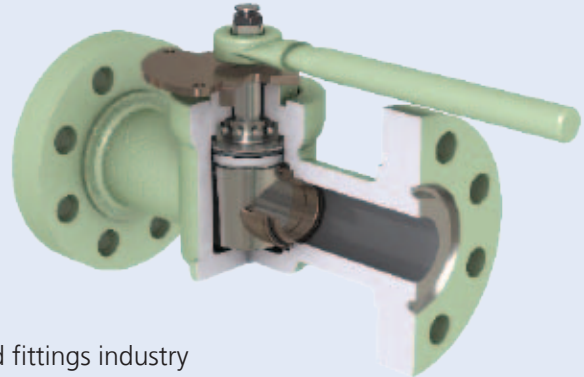

#### Metal-to-Metal Seating

- Hard coated plug (70 Rc)
- Erosion resistant design
- Maximum service life

#### Sealant Injection

- Internal sealant path to provide sealing on damaged seats
- Extended service life
- Lower torques

#### Other Features

- Ease of actuation
- Round ports-low turbulence/pressure drop
- Valve bores to match pipe bores
- API 6D and NACE MR0175 standard
- Fire-safe to API 6FA
- Locking device standard
- Valve position indicator standard

#### In Line Repairable

- Top entry, field repairable - no special tools, machining or training required
- Teflon encapsulated cover for easy removal
- Plug and seats fully interchangeable without lapping
- Built and tested in accordance with API 6D and B16.34
- Pressure Balanced Plus™ - low torque
- Full port or reduced port
- Blowout-proof plug - integral plug and stem
- Construction to NACE MR0175 standard
- Wrench, bar or worm gear operated - actuator compatible
- Renewable plug, seats and trim parts - fully interchangeable without lapping
- Round ports-low turbulence/pressure drop
- Equipped with a lock open/close position indicator

# TEXSTEAM SUPER G PLUG VALVES

## PART LIST

When ordering Parts, please furnish Item Number and Part Name as given below, plus Valve Model, Size and Working Pressure.

Item	No. Required	Description	Material
1	1	Collar retaining ring	Steel, nickel plated
2	1	Locking collar position indicator	Steel, nickel plated
3	1	Dirt excluder	PC Buna-N
4	1	Adjusting nut	See Note 1
■	5	Thrust bearing	Alloy steel
●■	6	Packing ring	Grafoil
●■	7	Body O-ring	Buna-N standard*
●■	8	Packing plate	316 Stainless steel
●■	9	Stem packing	Grafoil
●■	10	Backup ring	Teflon
●■	11	Stem O-ring	Buna-N standard*
▲■	12	Plug	1018 Steel chrome plated*
■	13	Seat	Nickel alloy ASTM B584
■	14	Seat O-ring	Buna-N standard*
■	15	Spacer ring	Alloy steel, nickel plated
	16	Stop screw	304 Stainless steel
	17	Lock washer	Stainless steel
	18	Lock plate	Carbon steel, zinc plated
▲	19	Lube check	316 Stainless steel
▲	20	Button head fitting	316 Stainless steel
	21	Body	See Note 1
●	1	Packing Plate Assembly Parts	
▲	1	Plug Assembly Parts	
■	1	Repair Kit	

\* Other materials available consult factory.

### Notes:

1. ANSI Class - ASTM A352 LCC;  
API - ASTM A487 GR4C

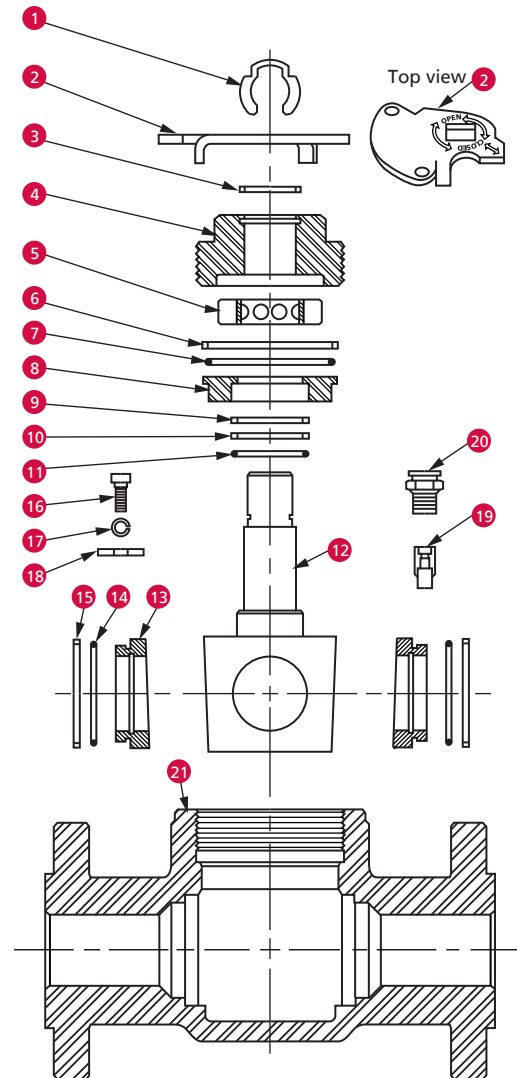

## TEXSTEAM SUPER G PLUG VALVES ACCESSORIES AND REPAIR KITS

### Stem Wrenches

Valve Size (in.)		Part Number	Weight (lbs.)
2	RP	9D-GB 1878	12
2	FP	9D-GB 1879	15
2 1/2	RP	9D-GB 1879	15
2 1/2	FP	9D-GB 1959	18
3	RP	9D-GB 1959	18
3	FP	9D-GB 1942	20
4	RP	9D-GB 1942	20
4	FP	9D-GB 1745	20
6	RP	9D-GB 1745	20

### Wrench Heads (Operated with Bar or Rod)

Valve Size (in.)		Part Number
2	RP	9D-GA 3247
2	FP	9D-GA 3248
2 1/2	RP	9D-GA 3248
2 1/2	FP	9D-GA 3249
3	RP	9D-GA 3249
3	FP	9D-GA 3250
4	RP	9D-GA 3250
4	FP	N/A Use Gear
6	RP	N/A Operator

### Adjusting Nut Wrenches

Valve Size (in.)		Part Number
2	RP	9D-GB 1728
2	FP	9D-GB 1729
2 1/2	RP	9D-GB 1729
2 1/2	FP	9D-GB 1730
3	RP	9D-GB 1730
3	FP	9D-GB 1731
4	RP	9D-GB 1731
4	FP	9D-GB 1772
6	RP	9D-GB 1772

### Repair Kits

Valve Size (in.)		Kit Part Number	Application	
			API 1000/ 1500/2000 ASME 400/600	API 3000/5000 ASME 900/ 1500/2500
2	RP	9D-GA 3113*-0	•	
2	RP	9D-GA 3113*-1		•
2	FP	9D-GA 3114*-0	•	•
2 1/2	RP	9D-GA 3114*-0	•	•
2 1/2	FP	9D-GA 3115*-0	•	•
3	RP	9D-GA 3115*-0	•	•
3	FP	9D-GA 3116*-0	•	•
4	RP	9D-GA 3116*-0	•	•
4	FP	9D-GA 3256*-0	•	•
6	RP	9D-GA 3256*-0	•	•
8	RP	Consult Factory		

Repair Kits include the plug, seats, all soft parts, packing plate, and thrust bearing.

\* When ordering Repair Kits, specify plug material A-Aluminum Bronze C-Hard Chrome Plated Steel.

Example: GA-3113C-0

# TEXSTEAM SUPER G PLUG VALVES

## REDUCE PORT

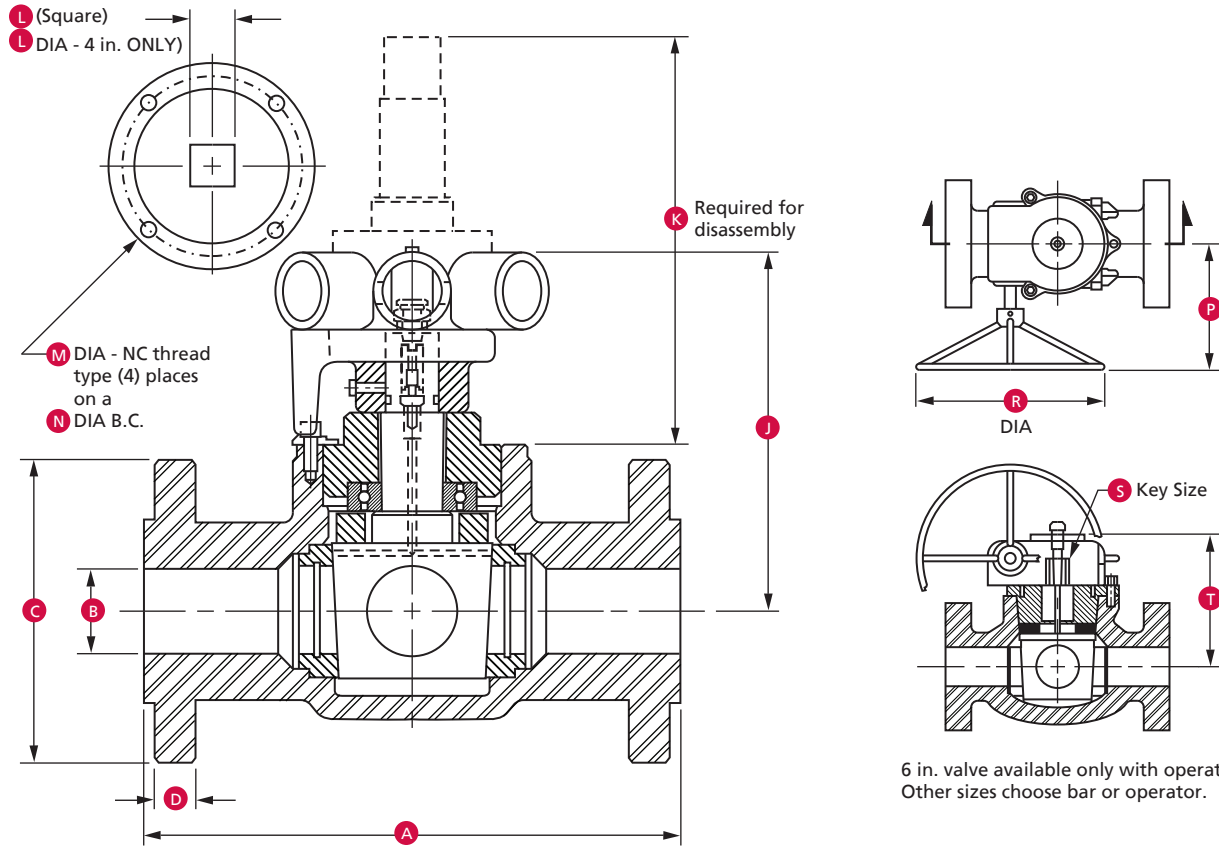

### Dimensions and Weights

Size (in.)	Pressure Class		A			B	C	D	J	K	L	M	N	P	R	S	T	Weight (lbs.)		
	ASME	PSI	RF	RJ	SE/BW													Flg.	Thrd.	
2	400/600	2000	11.50	11.63	7.50	1.75	6.50	1.25	7.06	7.00	-	-	-	-	-	-	-	-	54	28
	900/1500	3000/5000	14.50	14.63	8.75	1.75	8.50	1.75	7.56	7.25	-	-	-	-	-	-	-	-	98	35
	2500	-	17.75	17.88	-	1.75	9.25	2.25	7.56	7.25	-	-	-	-	-	-	-	-	146	-
2 1/2	400/600	2000	13.00	13.12	10.25	2.12	7.50	1.38	8.63	8.25	1.24	3/8-16	5.00	9.63	12	0.25 sq	8.56	114	48	
	900	3000	16.50	16.62	10.25	2.12	8.62	1.88	8.63	8.25	1.24	3/8-16	5.00	9.63	12	0.25 sq	8.56	153	50	
	1500	5000	16.50	16.62	10.25	2.12	9.25	1.88	8.63	8.25	1.24	3/8-16	5.00	9.63	12	0.25 sq	8.56	185	50	
	2500	-	20.00	20.12	-	2.12	9.25	2.50	8.63	8.25	1.24	3/8-16	5.00	9.63	12	0.25 sq	8.56	225	-	
3	400/600	2000	14.00	14.12	11.63	2.62	8.25	1.50	9.25	9.13	1.50	1/2-13	6.00	10.94	18	0.50 sq	9.53	182	74	
	900	3000	15.00	15.12	11.63	2.62	9.50	1.75	9.25	9.13	1.50	1/2-13	6.00	10.94	18	0.50 sq	9.53	210	82	
	1500	5000	18.50	18.62	11.63	2.62	10.50	2.13	9.25	9.13	1.50	1/2-13	6.00	10.94	18	0.50 sq	9.53	272	82	
	2500	-	22.75	22.88	-	2.62	12.00	2.88	9.25	9.13	1.50	1/2-13	6.00	10.94	18	0.50 sq	9.53	320	-	
4	400	-	16.00	16.12	-	3.12	10.00	1.63	10.13	10.50	1.75	1/2-13	6.88	10.94	30	0.50 sq	10.41	240	-	
	600	2000	17.00	17.12	12.00	3.12	10.75	1.75	10.13	10.50	1.75	1/2-13	6.88	10.94	30	0.50 sq	10.41	261	115	
	900	3000	18.00	18.12	12.00	3.12	11.50	2.00	10.13	10.50	1.75	1/2-13	6.88	10.94	30	0.50 sq	10.41	271	115	
	1500	5000	21.50	21.62	12.00	3.12	12.25	2.38	10.13	10.50	1.75	1/2-13	6.88	10.94	30	0.50 sq	10.41	314	120	
	2500	-	26.50	26.88	-	3.12	14.00	3.25	10.13	10.50	1.75	1/2-13	6.88	10.94	30	0.50 sq	10.41	474	-	
6	300	-	15.87	-	-	4.06	12.50	1.38	-	14.81	2.97	3/4-10	13.00	13.81	30	0.75 sq	12.06	420	-	
	600	2000	22.00	22.12	18.50	4.06	14.00	2.19	-	14.81	2.97	3/4-10	13.00	14.91	30	0.75 sq	12.06	571	-	
	900	3000	24.00	24.12	-	4.06	15.00	2.50	-	14.81	2.97	3/4-10	13.00	16.75	36	0.75 sq	12.06	700	-	
	1500	5000	27.75	28.00	-	4.06	15.50	3.62	-	14.81	2.97	3/4-10	13.00	16.75	36	0.75 sq	12.06	715	-	
	2500	-	-	36.50	-	4.06	19.00	4.15	-	14.81	2.97	3/4-10	13.00	16.75	36	0.75 sq	13.74	1227	-	
8	600	-	26.00	26.12	-	6.06	16.50	2.19	-	-	-	-	-	-	-	-	-	-	Consult Engineering	
	1500	-	32.75	33.12	-	6.06	19.00	3.62	-	-	-	-	-	-	-	-	-	-	Consult Engineering	



# TEXSTEAM SUPER G PLUG VALVES

## FULL PORT

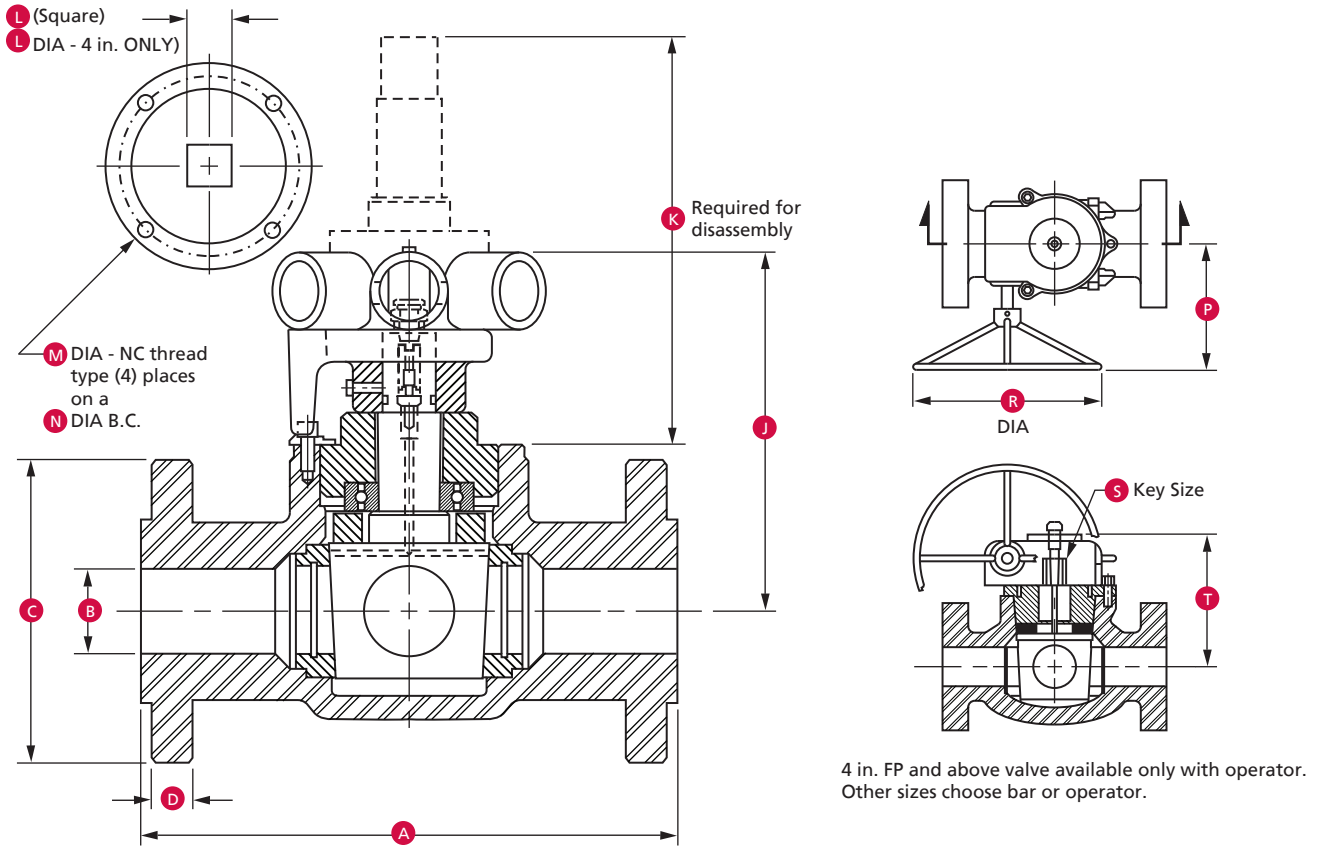

### Dimensions and Weights

Size (in.)	Pressure Class		A			B	C	D	J	K	L	M	N	P	R	S	T	Weight (lbs.)	
	ASME	PSI	RF	RJ	SE/BW													Fig.	Thrd.
2	300	-	11.12	-	-	2.12	6.50	0.875	8.63	8.25	1.24	3/8-16	5.00	9.63	12	0.25 sq	8.56	105	-
	400/600	2000	13.00	13.12	10.25	2.12	6.50	0.875	8.63	8.25	1.24	3/8-16	5.00	9.63	12	0.25 sq	8.56	117	57
	900	3000	15.00	15.12	10.25	2.12	8.50	1.75	8.63	8.25	1.24	3/8-16	5.00	9.63	12	0.25 sq	8.56	145	57
	1500	5000	15.38	15.50	10.25	2.12	8.50	1.75	8.63	8.25	1.24	3/8-16	5.00	9.63	12	0.25 sq	8.56	155	57
	2500	-	17.75	17.88	-	2.12	9.25	2.00	8.63	8.25	1.24	3/8-16	5.00	9.63	12	0.25 sq	8.56	175	-
2 1/2	400/600	2000	15.00	15.12	11.63	2.62	7.50	1.38	9.25	9.13	1.50	1/2-13	6.00	10.94	18	0.50 sq	9.53	183	90
	900	3000	17.00	17.12	11.63	2.62	9.63	1.88	9.25	9.13	1.50	1/2-13	6.00	10.94	18	0.50 sq	9.53	215	90
	1500	5000	17.88	18.00	11.63	2.62	9.63	1.88	9.25	9.13	1.50	1/2-13	6.00	10.94	18	0.50 sq	9.53	255	90
	2500	-	20.00	20.12	-	2.62	10.50	2.25	9.25	9.13	1.50	1/2-13	6.00	10.94	18	0.50 sq	9.53	285	-
3	300	-	15.25	-	-	3.12	8.25	1.12	8.81	10.50	1.75	-	-	-	-	-	-	215	-
	600	2000	17.50	17.62	12.00	3.12	8.25	1.50	10.13	10.50	1.75	1/2-13	6.88	10.94	30	0.50 sq	10.41	245	121
	900	3000	18.50	18.62	12.00	3.12	9.50	1.75	10.13	10.50	1.75	1/2-13	6.88	10.94	30	0.50 sq	10.41	272	126
	1500	5000	20.63	20.75	12.00	3.12	10.50	2.13	10.13	10.50	1.75	1/2-13	6.88	10.94	30	0.50 sq	10.41	320	126
	2500	-	22.75	22.88	-	3.12	12.00	2.63	10.13	10.50	1.75	1/2-13	6.88	10.94	30	0.50 sq	10.41	355	-
4	300	-	18.00	-	-	4.06	10.00	1.25	11.93	14.81	1.75	-	-	-	-	-	-	350	-
	600	2000	22.00	20.12	-	4.06	11.50	1.81	-	14.81	2.97	3/4-10	13.00	14.91	30	0.75 sq	12.06	439	-
	900	3000	22.00	22.12	-	4.06	11.50	1.94	-	14.81	2.97	3/4-10	13.00	16.75	36	0.75 sq	12.06	570	-
	1500	5000	24.62	24.75	-	4.06	12.25	2.19	-	14.81	2.97	3/4-10	13.00	16.75	36	0.75 sq	12.06	619	-
6	600	-	26.00	26.12	-	6.06	14.00	1.88				Consult Engineering							
	900	-	24.00	24.12	-	6.06	15.00	2.19				Consult Engineering							
	1500	-	27.75	28.00	-	6.06	15.50	3.25				Consult Engineering							

Note: 6 in. Full Port ASME 900 and ASME 1500 have the same Face-to-Face as Reduced Port.

## TEXSTEAM SUPER G PLUG VALVES

### COMPARISON CHART: SUPER G VS. CONVENTIONAL PLUG VALVE

Performance Feature	Super G	Plug Valve
Top entry – field repairable	Yes	No
Replaceable metal-to-metal seats	Yes	No
Part interchangeability	Yes	No
Integral plug and stem – no dead band	Yes	No
Low pressure drop	Yes	No
Round port/low turbulence	Yes	No
Full port	Yes	No
NACE standard	Yes	No
Sealant injection	Yes	Yes
Erosive service	Yes	Yes
H <sub>2</sub> S service	Yes	Yes
CO <sub>2</sub> service	Yes	Yes

Super G  
Solve Wedging Problems

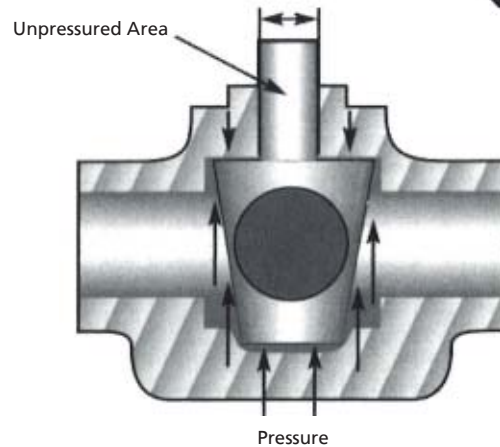

Unpressurized area at stem results in lifting force "F" which prevents wedging of plug.

### AVERAGE OPERATING TORQUE

2 in. Reduced Port through 8 in. Reduced Port (ft.-lbs.)

SIZE (in.)	2	2 1/2	3	4	4	6	6	8	8
PORT (in.)	1.75	2.12	2.62	3.12	3.44	4.06	5.189	6.06	6.81
psi									
0	22	55	88	88	88	110	132	165	306
500	44	110	132	154	154	303	396	1000	1850
1000	66	165	198	242	296	638	880	1829	3385
1500	88	220	264	330	508	858	1518	2659	4918
2000	121	275	330	413	678	1078	1761	3488	6453
2500	143	330	385	495	889	1320	2464	4290	7937
3000	165	385	440	583	1058	1540	2723	5225	9667
3500	193	440	495	671	1186	1782	3300	6050	11193
4000	209	495	572	770	1397	2024	3795	6807	12593
4500	237	550	635	858	1566	2255	4235	7636	14127
5000	264	605	682	935	1779	2475	4565	8466	15662
5500	286	660	748	1023	1936	2695	5170	9295	17196
6000	319	715	825	1111	2145	2915	5610	10120	18730
6500	338	770	875	1196	2332	3177	6160	10954	20264
7000	362	825	936	1282	2475	3410	6600	11375	N/A
7500	386	880	998	1368	2640	3644	7150	12172	N/A
8000	410	935	1059	1454	2860	3878	7480	12968	N/A
8500	436	990	1120	1541	3014	4112	8030	13765	N/A
9000	460	1045	1181	1627	3190	4345	8470	14562	N/A
9500	484	1100	1243	1714	3410	4579	9020	15358	N/A
10000	508	1155	1304	1801	3575	4813	9460	16155	N/A

All torques are in ft.-lbs.

These torques do not include a safety factor.

For actuator sizing add 50% to the listed torques.

## TEXSTEAM SUPER G PLUG VALVES

### FLOW COEFFICIENTS $C_v$

Valve Size (in.)	Pressure Class	Bort Type Type	Plug Port Port	End Port Port	L	Beta	Theata	ft	K1	K2	$C_v$	$K_v$
2	N/A	RP	1.75	2.06	-	0.850	30	0.019	0.057	0.320	224	194
2	N/A	FP	2.12	2.06	15.00	-	-	0.019	0.057	-	531	459
2 1/2	N/A	RP	2.12	2.62	-	0.809	30	0.018	0.054	0.480	296	256
2 1/2	N/A	FP	2.62	2.62	17.00	-	-	0.018	0.054	-	883	764
3 x 1.75	N/A	RP	1.75	3.12	18.63	0.561	30	0.018	0.054	5.173	128	111
3 x 2.12	N/A	RP Double Plug	2.12	3.12	23.00	0.808	10	0.018	0.054	0.745	190	164
3	N/A	RP	2.62	3.12	-	0.840	30	0.018	0.054	0.349	493	426
3	N/A	FP	3.12	3.12	18.50	-	-	0.018	0.054	-	1253	1084
4 x 2.62	N/A	RP	2.62	4.06	21.63	0.645	20	0.017	0.051	1.648	384	332
4 x 2.62	1500	RP	2.62	4.06	21.63	0.645	20	0.017	0.051	1.648	456	394
4	N/A	RP	3.12	4.06	-	0.768	30	0.017	0.051	0.713	584	505
4	N/A	FP	4.06	4.06	22.00	-	-	0.017	0.051	-	2182	1887
6 x 3.44	900	RP	3.44	6.06	28.00	0.568	30	0.015	0.045	4.762	503	435
6 x 3.44	1500	RP	3.44	6.06	28.00	0.568	20	0.015	0.045	3.338	601	520
6	N/A	RP	4.06	6.06	-	0.670	30	0.015	0.045	1.804	817	707
6 x 5.19	N/A	Flowline SCH80	5.19	5.76	28.26	0.901	20	0.015	0.045	0.132	2727	2359
6	N/A	FP6.06	6.00	6.06	29.00	-	-	0.015	0.045	-	5176	4477
8 x 5.19	N/A	RP	5.19	8.00	33.12	0.649	30	0.014	0.042	2.188	1294	1119
8	N/A	RP	6.06	8.00	-	0.758	30	0.014	0.042	0.767	2185	1890
8 x 6.81	N/A	Flowline SCH100	6.81	7.44	31.01	0.916	20	0.014	0.042	0.108	5023	4345

### Pressure Drop Across Valve

$$\Delta P = (\rho / 62.4) \times (Q / C_v)^2$$

Where:  $\Delta P$  = Pressure drop (psi)  
 $\rho$  = Fluid density (lbs/ft<sup>3</sup>)  
 $Q$  = Fluid flow rate (gallons/minute)  
 $C_v$  = Flow coefficient of valve

Given: Water at 200°F flows through a 4 in. Reduced Port (RP)  
 TEXSTEAM Super G plug valve at a flow rate of 400 gallons per minute.

$\rho$  = 60.1 (lbs/ft<sup>3</sup>) @ 200°F.  
 $Q$  = 400 gallons/minute.  
 $C_v$  = 584

Find: Pressure drop, DP, across valve.

Solution:  $\Delta P = (60.1/62.4) \times (400/584)^2$   
 $\Delta P = 0.963 \times (0.685)^2$   
 $\Delta P = 0.963 \times 0.469$   
 $\Delta P = 0.452$  psi

# TEXSTEAM SUPER G PLUG VALVES

## SINGLE BODY/DUAL PLUG DOUBLE-BLOCK-AND-BLEED PLUG VALVE

### Exclusive Features

- Double block-and-bleed in single valve length
- Reduced connections for faster Installation and reduced leak paths
- Built and tested in accordance with API 6D and B16.34
- Top entry, field repairable – no special tools or training required
- Pressure Balanced Plus™ – low torque
- Fire-safe to API 6FA
- Blowout-proof plugs – integral plug and stem
- Construction to NACE MR0175 standard
- Each closure assembly is wrench, bar, worm gear or actuator compatible
- Renewable plugs, seats and trim parts – fully interchangeable without lapping, special fitting or machining
- Round ports – low turbulence/pressure drop
- Equipped with lock open/close position indicators on each closure assembly

When ordering parts, please furnish Item Number and Part Name as given below, plus Valve Model, Size and Working Pressure. The quantities listed are for one plug assembly.

Item	No. Required	Description	Material
1	1	Collar retaining ring	Steel, nickel plated
2	1	Locking collar	Steel, nickel plated
3	1	Dirt excluder	Buna-N
4	1	Adjusting nut	See Note 1
5	1	Thrust bearing	Alloy steel
6	1	Packing ring	Graphite
7	1	Body O-ring	Buna-N standard*
8	1	Packing plate	316 Stainless steel
9	1	Stem packing	Graphite
10	1	Backup ring	Teflon
11	1	Stem O-ring	Buna-N standard*
12	1	Plug	1018 Chrome plated*
13	2	Seat	Nickel alloy ASTM B584
14	2	Seat O-ring	Buna-N standard*
15	2	Spacer ring	Alloy steel, nickel plated
16	1	Stop screw	300 Stainless steel
17	1	Lock washer	Stainless steel
18	1	Lock plate	Nickel plated
19	1	Lube check	316 Stainless steel
20	1	Button head fitting	316 Stainless steel
21	1	Body	ASTM A487 4C* Note 1

\* Other materials available consult factory.

Kit	Quantity	Description	Item Numbers Required
1	2	Packing Plate Assy. Part	6, 7, 8, 9, 10, 11
2	2	Plug Assembly Part	12, 19, 20
3	2	Repair Kit	6, 7, 8, 9, 10, 12, 13, 14, 15

### Notes:

1. ANSI Class - ASTM A352 LCC;  
API - ASTM A487 GR4C

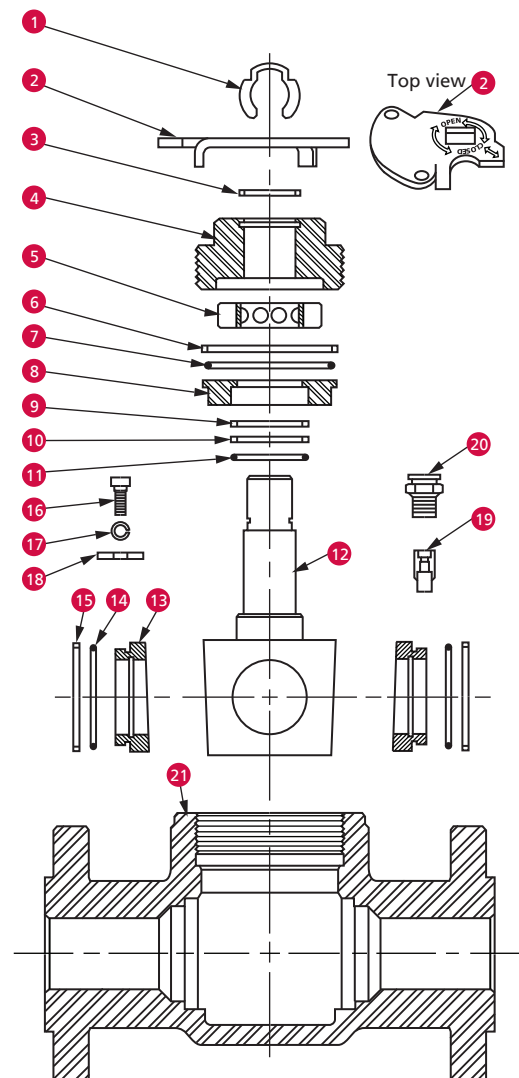

# TEXSTEAM SUPER G PLUG VALVES

## DOUBLE-BLOCK-AND-BLEED PLUG VALVE

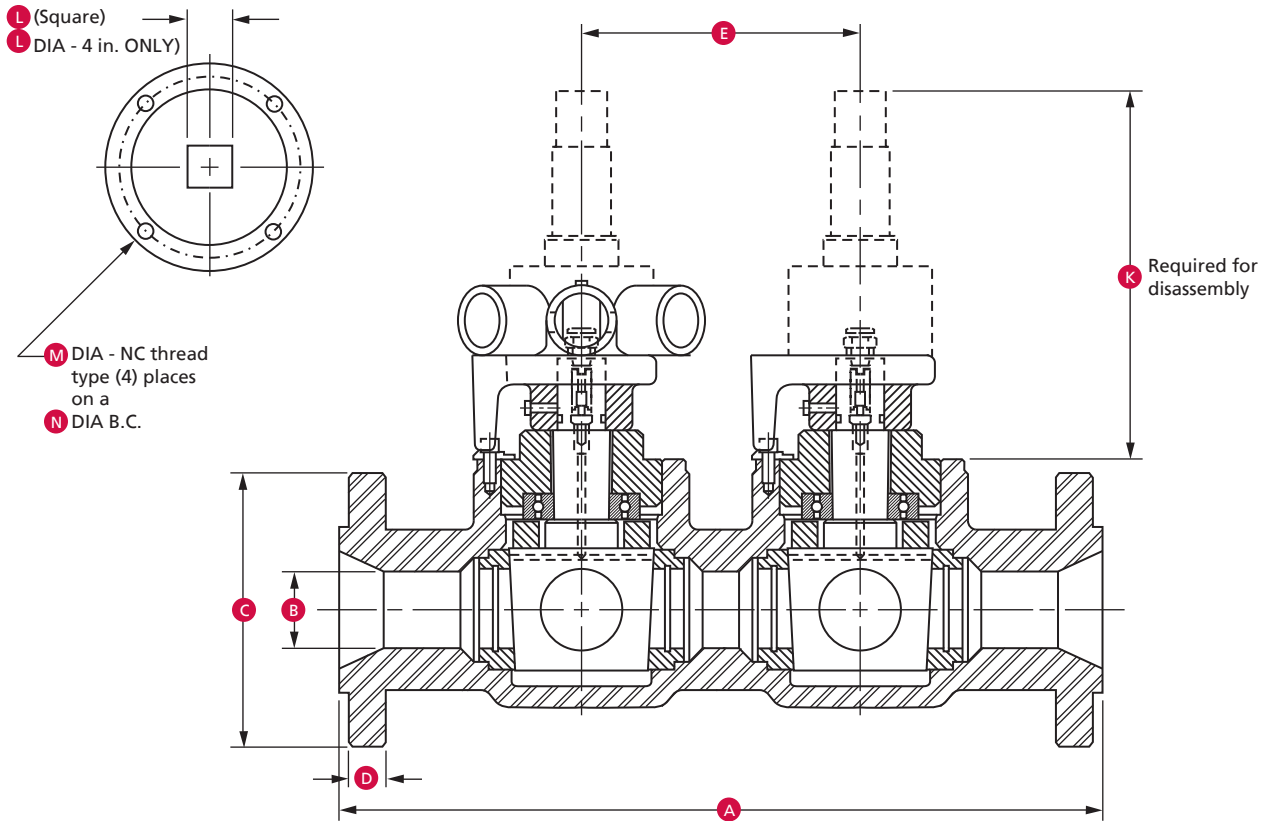

### Dimensions and Weights

Size	Pressure Class	A			B	C	D	E	K	L	M	N	P	R	S	T
		API	RF	RJ												
T	ASME	API	RF	RJ	B	C	D	E	K	L	M	N	P	R	S	T
2	900	3000	14.50	14.63	1.75	8.50	1.75	5.75	11.33	1.35Ø	5/16-18	4.12	8.19	10	0.25 sq.	11.95
	1500	5000	14.50	14.63	1.75	8.50	1.75	5.75	11.33	1.35Ø	5/16-18	4.12	8.19	10	0.25 sq.	11.95
	2500	-	17.75	17.88	1.75	9.25	2.25	6.50	11.33	1.35Ø	3/8-16	4.50	8.52	10	0.25 sq.	11.95
3	600	2000	14.00	-	1.75	8.25	1.50	5.50	10.93	1.25Ø	5/16-18	4.12	5.88	8	0.25 sq.	11.55
	900	3000	15.00	15.12	1.75	9.50	1.75	5.50	10.93	1.25Ø	5/16-18	4.12	5.88	8	0.25 sq.	11.55
	1500	5000	18.50	18.62	2.12	10.50	2.13	6.25	12.25	1.56Ø	1/2-13	5.13	8.19	10	0.25 sq.	12.72
4	2500	-	22.75	23.00	2.12	12.00	2.88	8.25	11.56	1.25Ø	1/2-13	6.00	9.81	14	-	12.03
	600	2000	17.00	17.12	1.75	10.75	1.50	6.25	11.33	1.36Ø	3/8-16	4.25	8.19	10	0.25 sq.	11.95
	900	3000	18.00	18.12	-	-	-	-	-	-	-	-	-	-	-	-
	1500	5000	21.50	21.62	2.62	12.25	2.38	8.25	12.25	1.75Ø	1/2-13	6.00	10.75	12	-	12.34
6	2500	-	26.50	26.88	3.12	14.00	3.25	9.50	16.75	2.50Ø	3/4-10	12.00	10.60	18	0.50 sq.	14.13
	600	2000	22.00	22.00	3.44	14.00	2.19	8.88	13.14	2.15Ø	3/4-10	11.25	9.81	14	0.50 sq.	12.84
	900	3000	24.00	24.12	3.44	15.00	2.50	8.88	13.14	2.15Ø	3/4-10	11.25	10.69	18	0.50 sq.	12.84
	1500	5000	27.75	28.00	3.44	15.50	3.62	9.50	13.14	2.15Ø	3/4-10	11.25	10.57	18	0.50 sq.	12.84
8	2500	-	-	36.50	4.09	19.00	4.75	13.25	18.81	2.97Ø	3/4-10	13.00	15.1	24	0.75 sq.	17.78
	1500	5000	-	33.12	4.09	19.00	3.62	12.00	18.81	2.97Ø	3/4-10	13.00	15.1	24	0.75 sq.	17.78
	2500	-	-	40.88	4.09	21.75	5.56	14.00	18.81	2.97Ø	3/4-10	13.00	15.1	24	0.75 sq.	17.78

NOTE: 6 in. full port ASME 900 and ASME 1500 have the same face-to-face as reduced port.

## CAMSERV™ AFTERMARKET SERVICES



The goal of Cameron's Aftermarket Services is to help our customers lower the total cost of valve ownership. To that end we offer a full range of services from over twenty-five Service Centers worldwide and can provide experienced personnel trained to meet the specific service requirements of each valve type.

### Aftermarket Services

- Supplies replacement valves and parts:
  - Maintains a full inventory of new and reconditioned valves for immediate delivery
  - Provides factory warranty support for all Cameron OEM brands as well as service for most other valves
- Field Service and Technical Support
  - Field service technicians on call 24 hours a day 7 days a week to handle service issues wherever they arise
  - Provides equipment installation, field repairs, as well as track and perform scheduled maintenance
- Customer Property Repair
  - The Customer Property Repair program allows Cameron's valve customers to store assets at our service centers throughout the world
  - Valves tracked in electronic database accessible through the Internet
- Remanufactured Products
  - Offers a broad range of API-compliant reconditioned equipment with fast delivery
- Total Valve Management
  - Supply and service automation and control packages
  - Assist with valve installation, commissioning and startup





## TRADEMARK INFORMATION

TEXSTEAM is a registered trademark which is owned by Cameron.

This document contains references to registered trademarks or product designations, which are not owned by Cameron.

Trademark	Owner
TEFLON	E.I. DuPont De Nemours & Company
17-4PH	Armco Advanced Materials Corp.

**Valves & Measurement****3250 Briarpark Drive, Suite 300****Houston, TX 77042****USA Toll 800 323 9160**

For the most current contact and location information go to: [www.c-a-m.com](http://www.c-a-m.com)

Cameron strives for continuous improvement in all aspects of our business. Cameron reserves the right to modify designs and specifications without notice or obligation. Nothing contained in this brochure is intended to extend any type of warranty, expressed or implied.