

# Fisher™ VBL Volume Booster

The Fisher VBL volume booster is used in conjunction with a positioner on a throttling control valve to increase stroking speed.

The booster incorporates fixed deadband, soft seat construction, and an integral bypass restriction to eliminate positioner saturation problems that can occur with volume boosters that do not have these features. Adjustment of the integral bypass restriction is necessary for system stability. This adjustment does not affect the deadband of the volume booster, but does permit the control valve to respond to small input signal changes without sacrificing steady-state accuracy. It also allows the booster to deliver high-volume output for fast stroking when large, rapid input signal changes occur.

The volume booster is used to improve stroking speed. If precision valve control is required, the use of a positioner is recommended. If the volume booster is to be used only with an actuator, for on-off control, the integral bypass restriction on the booster must be closed (turned fully clockwise).

Connectors and piping can be installed with the VBL volume booster for diagnostic testing.

## Features

- **Fast Response**—Booster delivers the volume needed for rapid actuator stroking when large input changes suddenly occur.
- **Adjustable Response**—Integral bypass restriction tunes the booster response so that smooth actuator motion follows the slow signal changes.
- **Efficient Operation**—Soft seats provide tight shutoff to reduce unnecessary air consumption and eliminate saturation of positioner relays.
- **Maintains Accuracy**—Booster permits high actuator stroking speeds upon demand without degrading the positioner steady-state accuracy.



X0648

## Specifications

### Input Signal

Positioner output

### Maximum Input Signal Pressure<sup>(1)</sup>

VBL-1 and VBL-3: 5.5 bar (80 psig)  
VBL-2 and VBL-4: 10.3 bar (150 psig)

### Input to Output Pressure Ratio

Fixed at 1 to 1

### Supply Pressure Ranges<sup>(1)</sup>

When used in conjunction with a positioner or other pneumatic accessory, always pipe the positioner and booster with one common supply through a Fisher 67D, 67DR, or 95H regulator (see figure 2). A high-capacity filter, such as the Fisher 262K, should be installed in the supply line to the regulator. Supply pressure also must not exceed the maximum pressure rating of the actuator.

### Operative Temperature Limits<sup>(1)</sup>

-40 to 93 °C (-40 to 200 °F)

### Maximum Flow Coefficients

See table 1

### Connections

Input Signal: 1/4 NPT  
Supply and Output: 1/2 NPT

### Hazardous Area Classification



Complies with the requirements of ATEX Group II Category 2 Gas and Dust

  **II 2 GD** Ex h IIC Tx Gb  
Ex h IIIC Tx Db

Maximum surface temperature (Tx) depends on operating conditions

Gas: T5, T6  
Dust: T85...T93

Meets Customs Union technical regulation TP TC 012/2011 for Groups II/III Category 2 equipment

 II Gb c T\*XX  
III Db c T\*XX 

### Safety Instrumented System Classification

SIL3 capable - certified by exida Consulting LLC

### Construction Materials

Body: Aluminum  
Diaphragms: HNBR with nylon fabric  
Upper and Lower Valves: HNBR  
O-Rings: HNBR  
Connectors for Diagnostic Testing: ■ Stainless steel or ■ brass

### Approximate Weight

1.0 kg (2.2 lb)

NOTE: Specialized instrument terms are defined in ANSI/ISA Standard 51.1 - Process Instrument Terminology.  
1. The pressure/temperature limits in this document and any applicable code or standard should not be exceeded.

**Table 1. Maximum Flow Coefficients**

Instrument	Supply Port Coefficients	Exhaust Port Coefficients
	C <sub>v</sub>	C <sub>v</sub>
VBL-1 volume booster	2.5	1.1
VBL-2 volume booster	2.5	1.1
VBL-3 volume booster	2.5	1.8
VBL-4 volume booster	2.5	1.8
FIELDVUE™ DVC6200, DVC6200 SIS, DVC6200f, DVC6200p, DVC6000, DVC6000 SIS, DVC6000f digital valve controllers	0.37	0.31
FIELDVUE DVC2000 digital valve controller:		
Low pressure relay	0.13	0.15
High pressure relay	0.19	0.20
Fisher 3570 valve positioner	0.25	0.25
Fisher 3582 valve positioner	0.17	0.19
Fisher 3610J, 3610JP, 3611JP, 3620J, 3620JP, 3621JP valve positioners	0.37	0.30

# Principle of Operation

Refer to figures 1, 2, and 3. Because of the restriction, large input signal changes register on the booster input diaphragm sooner than in the actuator. A large, sudden change in the input signal causes a pressure differential to exist between the input signal and the output of the booster. When this occurs, the diaphragms move to open either the supply port or the exhaust port, whichever action is required to reduce

the pressure differential. The port remains open until the difference between the booster input and output pressures returns to within the deadband limits of the booster. With the bypass restriction adjusted for stable operation, signals having small magnitude and rate changes pass through the bypass restriction and into the actuator without initiating booster operation.

Both the supply and exhaust ports remain closed, preventing unnecessary air consumption and possible saturation of positioner relays.

Figure 1. Volume Booster Sectional View

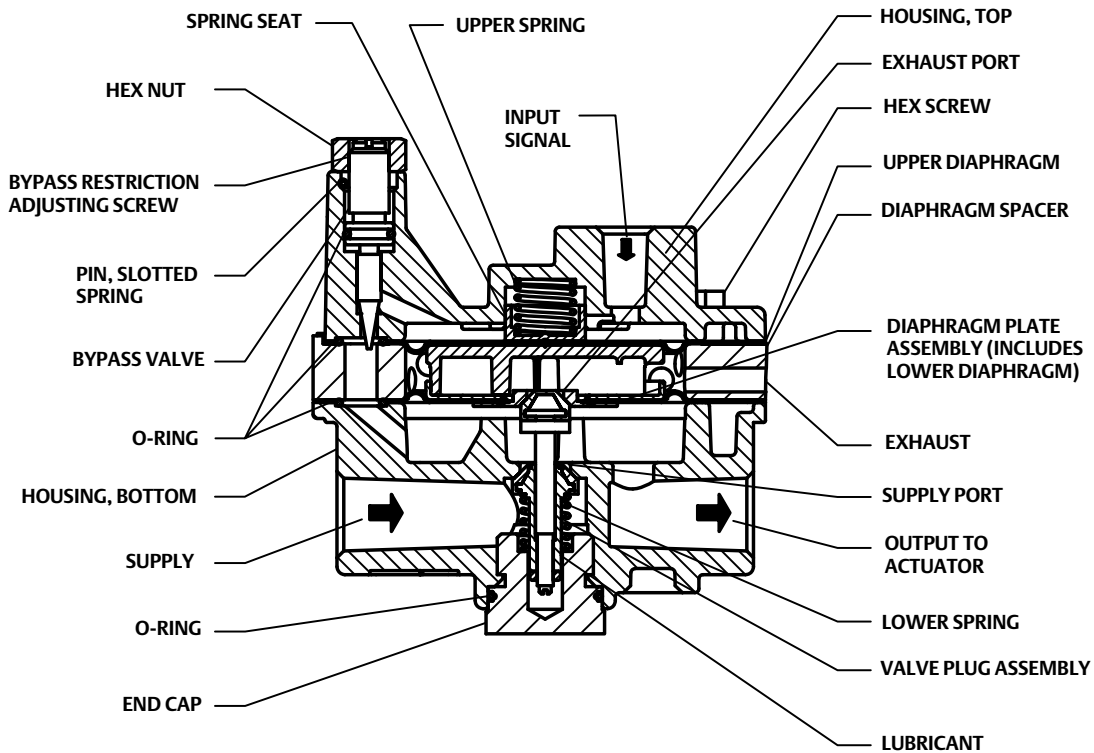

GE26237-Section

Figure 2. Typical Installation with Piston Actuator

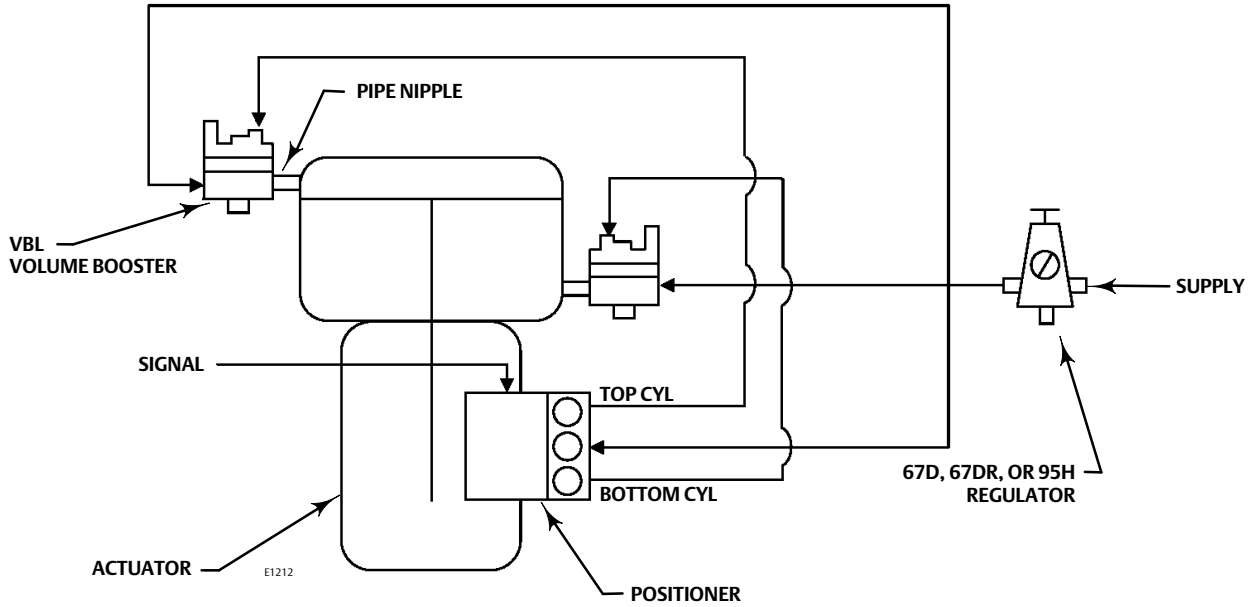
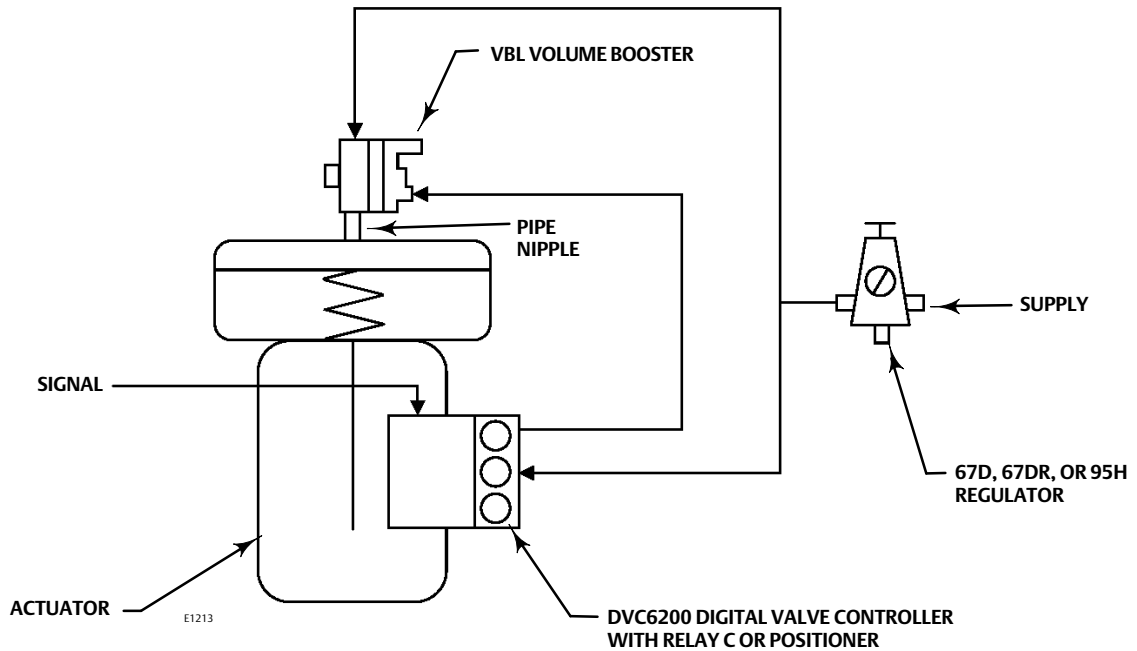

Figure 3. Typical Installation with Diaphragm Actuator



## Installation

Figures 2 and 3 show typical installations for the VBL volume booster on piston and diaphragm actuators. A single regulator that supplies both the positioner and booster (or boosters) is recommended. The supply medium must be clean, dry, oil-free air or non-corrosive gas.

Keep in mind that many actuators require larger casing or cylinder connections to take full advantage of the booster's ability to deliver its high-volume output. Dimensions are shown in figure 4. Ensure that the supply pressure is connected to correspond with the flow arrow on the booster.

Verify that the capacity of the regulator meets the stroking capacity requirements.

Figure 4. Dimensions

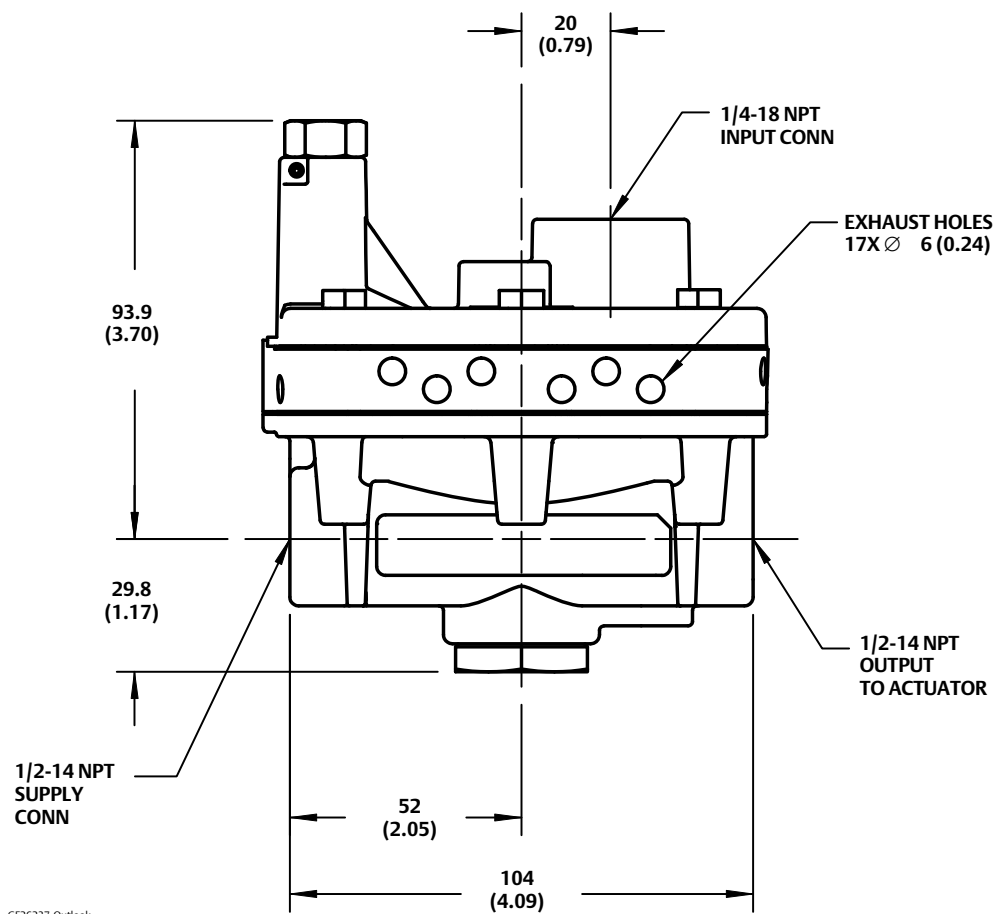

GE26237-Outlook

mm  
(INCH)

## Ordering Information

Specify stroking speed information when being mounted at the factory, for proper tuning of the instruments. Specify either critical or non-critical stroke speed time.

---

### Note

Critical stroke speed time example: valve to stroke in both directions in 4 seconds or less.

Non-critical stroke speed time example: valve to stroke in approximately 4 seconds in both directions.

---

Neither Emerson, Emerson Automation Solutions, nor any of their affiliated entities assumes responsibility for the selection, use or maintenance of any product. Responsibility for proper selection, use, and maintenance of any product remains solely with the purchaser and end user.

Fisher and FIELDVUE are marks owned by one of the companies in the Emerson Automation Solutions business unit of Emerson Electric Co. Emerson Automation Solutions, Emerson, and the Emerson logo are trademarks and service marks of Emerson Electric Co. All other marks are the property of their respective owners.

The contents of this publication are presented for informational purposes only, and while every effort has been made to ensure their accuracy, they are not to be construed as warranties or guarantees, express or implied, regarding the products or services described herein or their use or applicability. All sales are governed by our terms and conditions, which are available upon request. We reserve the right to modify or improve the designs or specifications of such products at any time without notice.

Emerson Automation Solutions  
Marshalltown, Iowa 50158 USA  
Sorocaba, 18087 Brazil  
Cernay 68700 France  
Dubai, United Arab Emirates  
Singapore 128461 Singapore

[www.Fisher.com](http://www.Fisher.com)

