

September 2015

Types N551 and N851 Snappy Joe™ Emergency Shutoff Valves



WARNING

Failure to follow these instructions or to properly install and maintain this equipment could result in an explosion and/or fire causing property damage and personal injury or death.

Fisher® equipment must be installed, operated and maintained in accordance with federal, state and local codes and Emerson Process Management Regulator Technologies, Inc. (Emerson™) instructions. The installation in most states must also comply with NFPA No. 58 or ANSI K61.1 standards.

Only personnel trained in the proper procedures, codes, standards and regulations of the LPG or anhydrous ammonia (NH₃) industries should install and service this equipment.

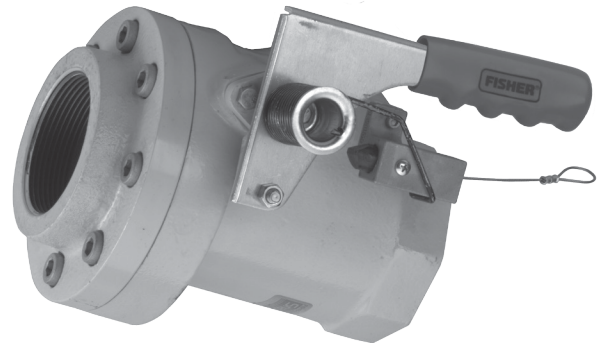

Figure 1. Type N551 in Closed Position

Introduction

Scope of the Manual

This manual provides installation and maintenance instruction for the Types N551 and N851 Emergency Shutoff Valves and Accessories.

Description

Type N551 Snappy Joe (Figure 1) emergency shutoff valve is UL® Listed for service in Propane or Anhydrous Ammonia (NH₃).

Type N851 emergency shutoff valve is intended for all other compressed gas service. Reference to Type N551 also refers to Type N851 unless otherwise specified.

The valves may be installed on both ends of transfer hoses where the hose connects the bulk plant piping to the bobtail, transport or tank car. They provide a quick way of shutting off gas flow in the event of a hose rupture and meet the requirements for such service when correctly installed with a remote release and proper piping support. The Type N551 valve is lever operated, latch-open and quick closing valve. A fusible element in the latch melts if the temperature reaches 212°F / 100°C, allowing the valve to close.

The following accessories are also covered:

- Type P164B – Cable Release Assembly
- Type P327D – Remote Pneumatic Release Assembly

UL® is a mark owned by Underwriters Laboratories.



www.fisherregulators.com



Types N551 and N851

Specifications

The Specifications table lists specifications for the Types N551 and N851 valve which is designed for butane, propane or NH₃ service at ambient temperatures. Contact your local Sales Office if the valve is to be used on any other service, fluid, compressed gas or temperature condition.

TYPE	BODY SIZES, NPS*	PROPANE FLOW AT 2 psi / 0.14 bar DIFFERENTIAL, GPM / l/min
N551-10, N851-10, N851K-10 ⁽¹⁾	1-1/4 FNPT	150 / 568
N551-16, N851-16, N851K-16 ⁽¹⁾	2 FNPT	295 / 1117
N551-24, N851-24, N851K-24 ⁽¹⁾	3 FNPT	850 / 3127

Maximum Inlet Pressure: 400 psig / 27.6 bar⁽²⁾

Temperature Capabilities: -20 to 160°F / -29 to 71°C

1. FFKM (Kalrez[®]) gasket and seals.

2. The pressure limits in this Instruction Manual and any applicable standard or code limitation should not be exceeded.

* Nominal Pipe Size.

Operation



The Type N551 handle and shaft may break if the valve is forced open against the gas flow and before pressure is equalized on each side of the main valve disc.

To Open a Closed Valve:

Close a shutoff valve downstream of the Type N551. Pull the Type N551 handle counterclockwise. There will be an opening as inlet pressure helps hold the valve disc closed against the seat. The initial opening force on the handle opens a pilot valve in the main valve disc, permitting pressure to build-up downstream. When differential pressure across the main disc has been reduced, the Type N551 can be opened without further difficulty by continuing to lift the handle to the open position. When the handle is fully open (handle perpendicular to the pipe) the latch engages to hold the valve open.



Because the valve is spring closed (aided by pressure), the handle can snap down with considerable force when closing. Keep hands and fingers away from the handle as it closes.

To Close an Open Valve:

Pushing the handle down (handle parallel to the pipe) will close the valve.

From a remote location, pulling on the remote cable or exhausting pneumatic pressure from the Type P327D will retract the plunger allowing the Type N551 to close. If emergency conditions cause the fusible element to reach a temperature of 212°F / 100°C, the element, which attaches the handle to the shaft, pulls apart and allows the valve to close.

Installation

Shutoff Direction

The valves shall be installed in the fixed piping between a storage tank and the transfer hose connection at the truck or tank car loading/unloading area. They can be placed in a line used either for filling or withdrawing from the storage tank (or both). The valve shall be installed to shutoff flow from the tank towards the hose, enabling the valve to control product loss in case of a hose break.



The Type N551 valve is a spring closed (aided by pressure) and shutoff flow in one direction only. THE NAMEPLATE FLOW ARROW SHOWS FLOW DIRECTION FOR VALVE SHUTOFF (see Figure 6). The arrow shall point to the hose connection. Improper flow direction will not shutoff flow through the line.

When installed in horizontal piping, install with the nameplate up. The valve can be installed in vertical piping with the flow arrow pointing to the desired flow direction for valve shutoff. In some cases the normal flow through the valve may be opposite the shutoff direction (like a back check valve).

Bulkhead Protection

The valve should be installed near the hose connection, but shall be positioned so that any undue strain resulting from a hose pull cannot shear the valve or its inlet piping from the storage area piping. The piping shall always be firmly supported and anchored to be sure of meeting the requirement.

One preferred method of installation is shown in Figure 2 where the pipe connection to the valve and to the hose coupling is securely anchored in a solid bulkhead.

A bobtail truck can provide enough pull on the hose connection to cause a break in the system. That break must not occur between the Type N551 and the storage tank.

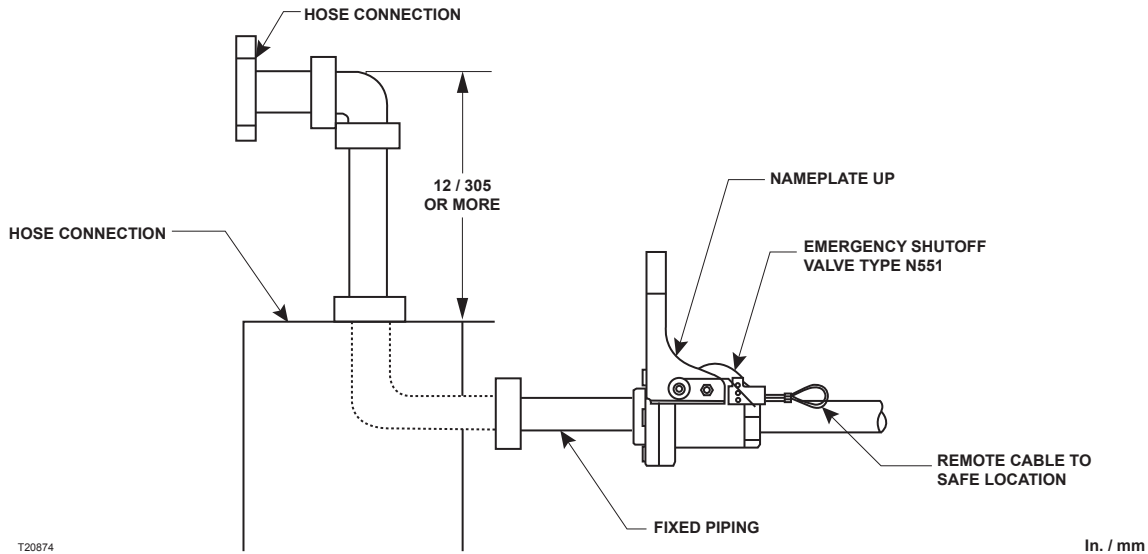

Figure 2. Typical Installation of Type N551 Using Remote Cable Release

Fusible Element Location

A fusible element that will close the Type N551 shall be located within five feet of the hose connection. If the Type N551 is placed within five feet of the hose connection, this requirement is met. If not, an additional fusible element must be provided near the hose coupling which will activate a remote release.

Remote Release Installation

In all installations a remote release shall be connected to the latch on all emergency valves at the bulkhead. The remote release has to extend to a place where it can be easily reached to close the Type N551 valve(s) in the event that an emergency makes the valve(s) inaccessible. The remote release shall shutdown all emergency valves when activated. Remote release activation may be by cable or pneumatic hook-up.

Cable Hook-Ups



Remote release cables shall be installed so that they will close the Type N551 valve(s) when pulled from the farthest remote location. Cable shall operate smoothly, over pulleys and/or through conduit. Do not kink cable or run cable around sharp corners. If installed in conduit, keep water out of conduit. Frozen water, dirt or dried mud in the conduit will render the remote release inoperable.

Remote releases used on Type N551 valve shall not:

- (a) be made from plastic or fiber rope;
- (b) have any kind of fusible link which could melt and prevent the cable from pulling the Type N551 latch.

To provide a remote release, aircraft cable can be connected to the short looped cable on the valve and run to the remote release point over pulleys or through conduit. Adjust the cable so that minimal pull is required to close the emergency valves.

Type P164B Cable Installation

To connect a Type P164B remote release assembly, which is supplied with 50 ft. / 15 m of cable:

1. Run the inner cable and housing assembly to the remote release point. Leave enough slack on each end for a smooth, flowing path, without sharp bends in the cable, between the Type N551 latch block and remote release handle.
2. If it is necessary to cut the cable to a shorter length, pull about one foot of inner cable from the Type N551 latch block cable end (end with the 3/16 x 1/2 in. / 4.8 x 13 mm long cylindrical cast fitting, see Figure 3) from the housing.

At the remote release end (other end of inner cable/housing assembly), cut the housing and inner cable at desired length. Push the excess inner cable back through the housing so that the bare cable extends from the remote release end.

3. Close the Type N551 valve. Handle parallel to pipe.
4. If necessary for additional working space, remove the long end of the external spring from under the latch block. **DO NOT REMOVE SPRING FROM HANDLE.**
5. Loosen the slotted screw, Figure 3, on the Type N551 valve's latch block until the plunger can be pulled from the latch block.
6. Disconnect the short looped cable and remove it.
7. Insert the Type P164B inner cable end cylindrical cast fitting through the latch block rear conical hole and connect the cylindrical cast fitting into the side slot in the plunger.

Types N551 and N851

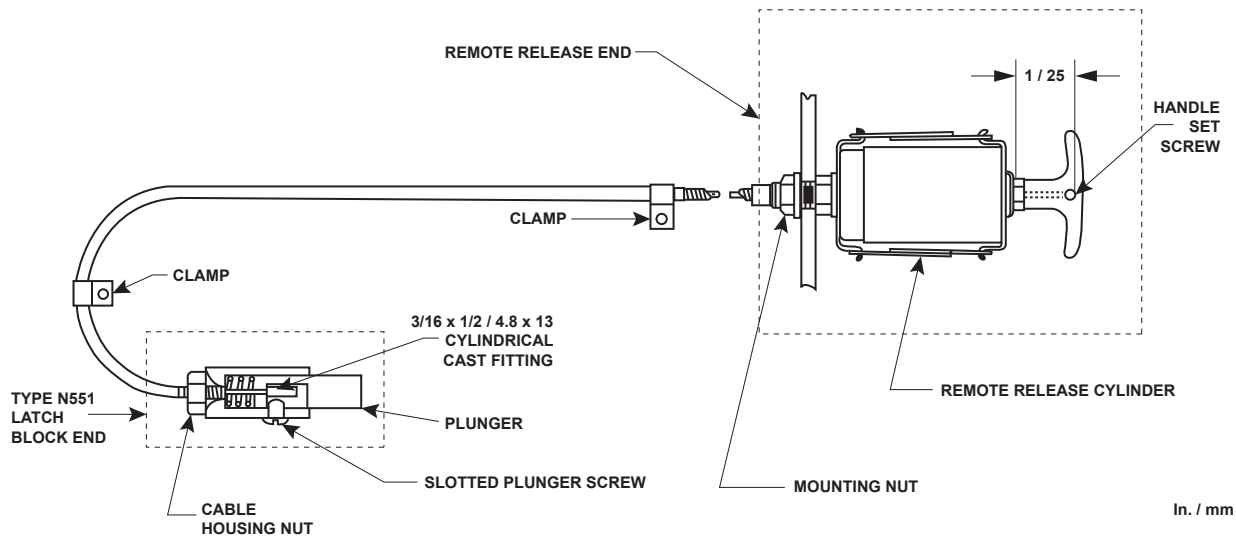

Figure 3. Type P164B Cable Release Installation Schematic

8. Replace the plunger in the latch block, oriented so the screw will enter the plunger slot. Tighten the screw.
9. The end of the cable housing and cable housing nut fit into the conical end of the latch block. Pulling the excess inner cable through the housing from the remote release end will hold the housing in the latch block.
10. Mount the remote release cylinder assembly to a suitable support at the remote release location (7/16 in. / 11 mm diameter mounting hole) but do not tighten the mounting nut.
11. At the remote release end, strip about 3/4 in. / 19 mm of vinyl cover from the cable housing end.
12. Insert the inner cable completely through the release cylinder. Screw the bare cable housing end into the remote release cylinder by rotating the cylinder. Tighten the mounting nut.
13. Pull any slack from the inner cable, just tight enough so that the latch is not activated, and cut the inner cable off 1 in. / 25 mm past the remote release cylinder end.
14. Insert the 1 in. / 25 mm bare inner cable into the remote release handle shaft. Push the remote release handle completely into the remote release cylinder. Tighten the handle set screw to secure the handle to the inner cable.
15. Test the remote release and Type N551 operation from the most remote location. Rotate handle counterclockwise to open valve. Valve must stay open. HANDLE AND VALVE MUST QUICKLY “SNAP” CLOSED when (a) the remote release cable is pulled and (b) handle is pushed closed from the open position.



WARNING

All open Type N551 emergency valve(s) attached to the remote release must properly close when the release cable is pulled.

Pneumatic Hook-Up

Type P327D Pneumatic Release Block Installation

If several valves are installed at the same location, remote release may be accomplished with the Type P327D pneumatic release block which replaces the cable latch block installed on the Type N551 valve.

To install the Type P327D, see Figure 4:

1. Close the Type N551 valve. Handle is parallel to the pipe.
2. Remove the long end of the external spring from under the latch block. **DO NOT REMOVE SPRING FROM HANDLE.**
3. Remove latch bolt(s). Older valves will have 2 bolts. **DISCARD CABLE LATCH BLOCK.**



CAUTION

Possible hand and finger pinch point between closing Type N551 handle and latch block. Handle closes quickly and with extreme force. Keep hands and fingers away from handle as it closes.

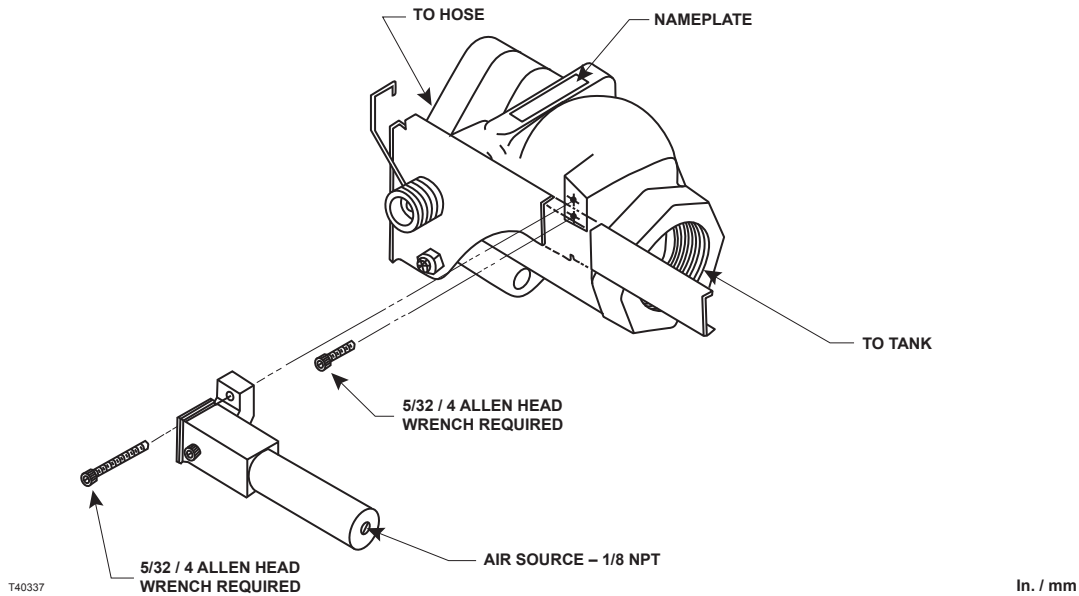

Figure 4. Type P327D Pneumatic Cylinder Installation

4. Use a 5/32 in. / 4 mm Allen head wrench to screw 1/4 in. / 6.4 mm long bolt into bottom hole.
5. Tighten until bolt head seats firmly on body.
6. Place latch block on body with lower blind hole over bolt in body.
7. Install 3/4 in. / 19 mm long bolt through second hole and firmly tighten with 5/32 in. / 4 mm Allen head wrench.
8. Refasten long end of spring under latch block by **ROTATING 180 DEGREES CLOCKWISE.**
9. Attach the remote air source to the cylinder end with appropriate supply tubing and valving. A regulated air supply of **30 to 70 psig / 2.1 to 4.8 bar** to the Type P327D pneumatic release cylinder is required for proper operation.

CAUTION

Possible hand and finger pinch point between closing Type N551 handle and latch block. Handle closes quickly and with extreme force. Keep hands and fingers away from handle as it closes.

10. Test the remote release and Type N551 operation. Rotate handle counter clockwise to open valve. Valve must stay open. **HANDLE AND VALVE MUST QUICKLY "SNAP" CLOSED** when (a) air pressure is exhausted from Type P327D pneumatic remote release and (b) the handle is pushed closed from the open position.

WARNING

All open Type N551 Emergency Valve(s) attached to the remote pneumatic release system must properly close when air pressure is exhausted from the system. Remote release controls must quickly exhaust pressure from the supply line to close emergency valves.

Optional Motion Release Cable

With either the cable or pneumatic remote release hook-ups, it is possible to connect an additional cable from the Type N551's operating handle to the truck along the transfer hose(s). This cable would close the valve if the hose(s) is stretched (driver does not disconnect) beyond a preselected limit. The hook-up does not affect the normal operation of the valve.

Motion Release Cable Installation

1. Connect a suitable release cable such as stainless steel aircraft cable to a standard "S" hook. Attach the "S" hook to the Type N551 handle as shown in Figure 5.
2. The cable should run through the bulkhead just below and to the side of the pipe. The cable should be in line with the operating lever, refer to Figure 5.

Types N551 and N851

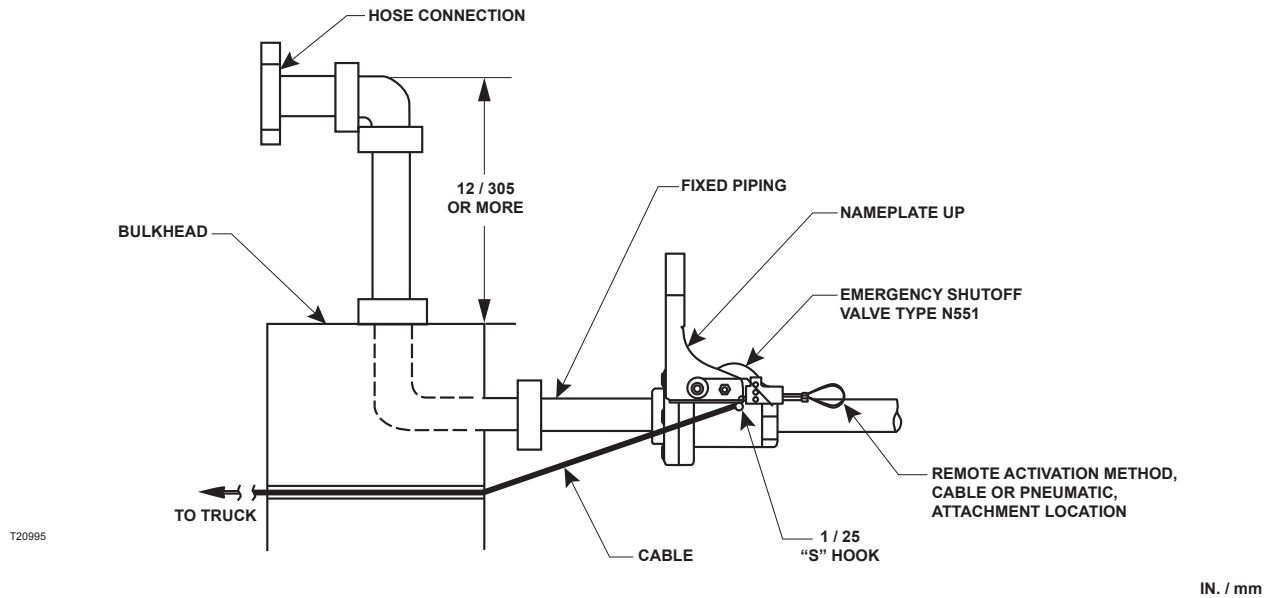

Figure 5. Motion Release Cable Installation (Optional)

3. Leave enough slack in the cable to allow the Type N551 lever to move freely but not close during normal hose movement or hook-up.
4. Run the cable along the hose. Tape or secure it to the hose. Fasten the cable securely to the “truck” end hose connection.

When the hose stretches more than the amount of slack left in the cable, the tightening cable will pull the lever down and close the Type N551 valve.

2. Make sure that the lever, latch and release are working smoothly. The latch parts and lever are easily accessible for replacement or repair by removing the securing bolts.
3. Check for packing and joint leakage.

Replacing Internal Parts

Verify that the Emergency Shutoff Valve is Type N551 and not the previous version Type N550 by confirming that it is marked with “1” as shown in Figure 7.

Type N551 can be repaired in the field. However, due to the special fire resistant seals and assembly techniques, repairs should be done only by trained personnel. If repair should become necessary, contact your local LPG Equipment Distributor for information and assistance.

Only parts manufactured by Emerson™ should be used for the repair of Fisher® Type N551 Valve. Be sure to give the complete type number of the Type N551 when corresponding with your local distributor.

Type N551 valve that have been disassembled for repair must be tested for proper operation before being returned to service.

Maintenance



Only qualified service personnel should attempt to repair these valves. Before starting any type of repair, close off the upstream valves and remove all pressure from both the inlet and outlet of the Type N551 Emergency Shutoff Valve.

At least once a month, inspect and check the following things:

1. See that the remote release is properly connected, works freely and is not worn. Operate the release to make certain it closes the valve. If the valve closes

Types N551 and N851

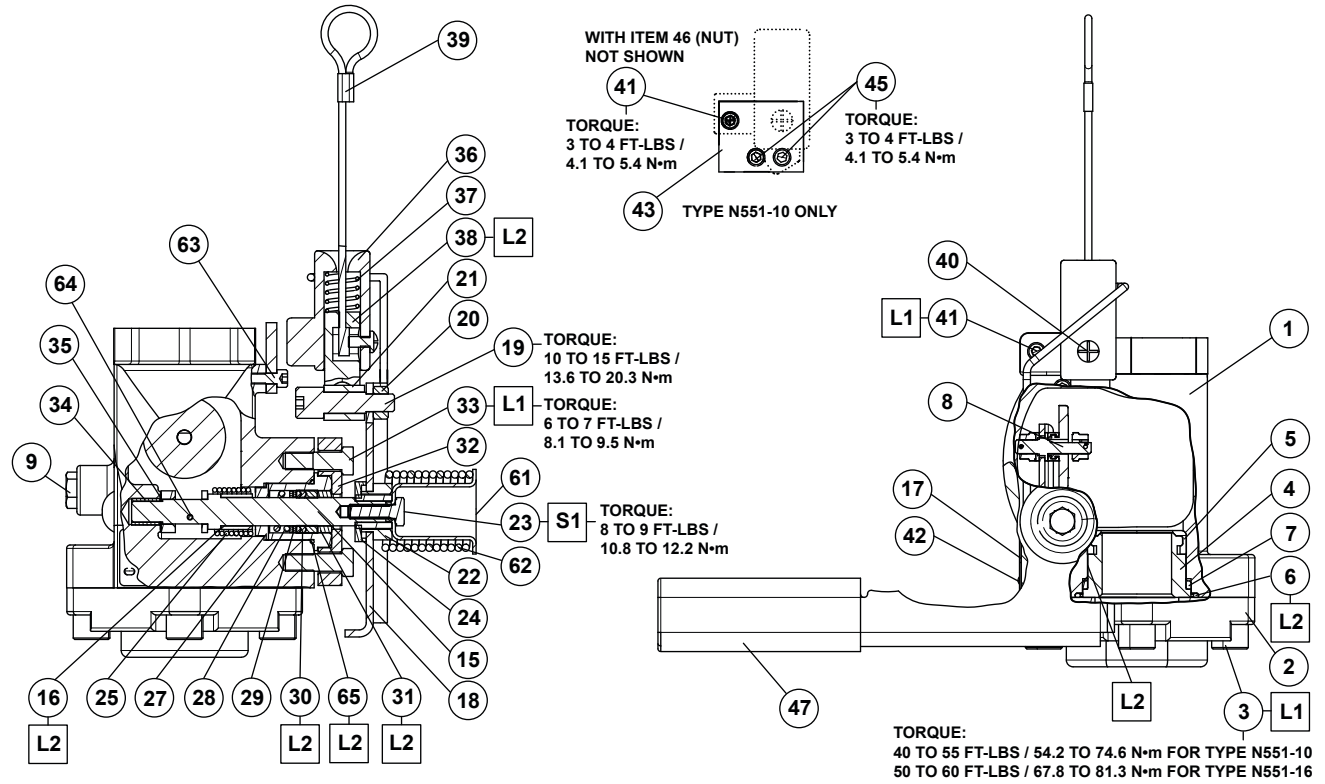

- APPLY LUBRICANT (L) OR SEALANT (S)⁽¹⁾:
- L1 = High Temperature Anti-Seize and Extreme Pressure Nickel Lubricant
 - L2 = Multi-Purpose Polytetrafluoroethylene (PTFE) Lubricant
 - S1 = Medium Strength Threadlocker
1. Lubricants and sealants must be selected such that they meet the temperature requirements.

Figure 6. Type N551 Shutoff Valve Assemblies

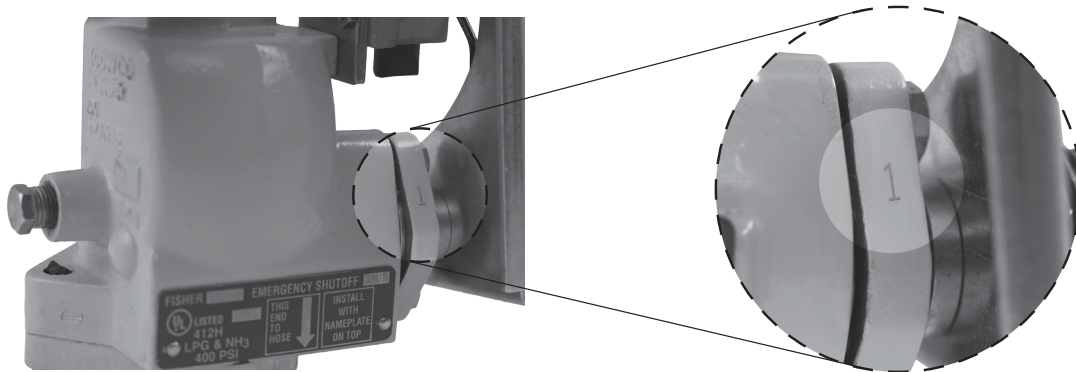

Figure 7. Type N551 body marked with "1"

Types N551 and N851

Parts List

Key	Description	Part Number	Key	Description	Part Number
	Packing Assembly Kit Includes packing stack (key 30), O-ring (key 65) and two washers (key 29).	RCN551T0012	16	Sleeve, Nylon (PA) Type N551-10 (NPS 1-1/4 FNPT) Type N551-16 (NPS 2 FNPT) Type N551-24 (NPS 3 FNPT)	T12842T0012 T12842T0012 T12893T0012
1	Body, Ductile iron Type N551-10 (NPS 1-1/4 FNPT) Type N551-16 (NPS 2 FNPT) Type N551-24 (NPS 3 FNPT)	ERSA05033A0 ERSA05031A0 ERSA05032A0	17	Nameplate	-----
2	Flange, Ductile iron Type N551-10 (NPS 1-1/4 FNPT) Type N551-16 (NPS 2 FNPT) Type N551-24 (NPS 3 FNPT)	ERAA00718A0 T12783T0YW2 T20699T0YW2	18	Handle, Aluminum	T20677T0012
3	Cap Screw Type N551-10 (NPS 1-1/4 FNPT) (4 Required) Type N551-16 (NPS 2 FNPT) (4 Required) Type N551-24 (NPS 3 FNPT) (8 Required)	T12864T0012 1E760432992 1E760432992	19	Shoulder bolt, Alloy steel-plate	T12853T0012
4*	Seat Ring, Stainless steel Type N551-10 (NPS 1-1/4 FNPT) Type N551-16 (NPS 2 FNPT) Type N551-24 (NPS 3 FNPT)	T12857T0012 T12548T0012 T12887T0012	20	Nut, Carbon steel	T1166228982
5*	Sealing Ring, Nitrile (NBR) Type N551-10 (NPS 1-1/4 FNPT) Type N551-16 (NPS 2 FNPT) Type N551-24 (NPS 3 FNPT)	T12858T0012 T12547T0012 T12891T0012	21	Roller, Nylon (PA)	T12847T0012
6*	O-ring, Nitrile (NBR) Type N551-10 (NPS 1-1/4 FNPT) Type N551-16 (NPS 2 FNPT) Type N551-24 (NPS 3 FNPT)	10A3800X032 1H8762X0022 T12759T0012	22	Fuse link, Brass	T13500T0012
7*	Gasket, Graphite Type N551-10 (NPS 1-1/4 FNPT) Type N551-16 (NPS 2 FNPT) Type N551-24 (NPS 3 FNPT)	T12863T0012 T12839T0012 T12890T0012	23	Bolt, Zinc-plated steel	1B290524052
8	Poppet Sub-Assembly Type N551-10 (NPS 1-1/4 FNPT) Type N551-16 (NPS 2 FNPT) Type N551-24 (NPS 3 FNPT)	T12964T0012 T12965T0012 T12966T0012	24	Retainer, Zinc-plated steel	T12843T0012
9	Pipe Plug	T13718T0012	25	Spring, 302 Stainless steel Type N551-10 (NPS 1-1/4 FNPT) Type N551-16 (NPS 2 FNPT) Type N551-24 (NPS 3 FNPT)	T12844T0012 T12844T0012 T13005T0012
15	Shaft, Stainless steel Type N551-10 (NPS 1-1/4 FNPT) Type N551-16 (NPS 2 FNPT) Type N551-24 (NPS 3 FNPT)	ERSA05039A0 ERSA05038A0 ERSA05040A0	27	Gland, 303/416 Stainless steel Type N551-10 (NPS 1-1/4 FNPT) Type N551-16 (NPS 2 FNPT) Type N551-24 (NPS 3 FNPT)	ERSA05036A0 ERSA05036A0 ERSA05037A0
			28*	Spring, 302 Stainless steel	T12851T0012
			29*	Washer, Carbon steel (2 Required)	T1207524082
			30*	Packing Stack	T12854T0012
			31*	Follower, 174 Stainless steel	T12841T0012
			32	Retainer, Steel	ERSA05035A0
			33	Bolt, Stainless steel (2 Required)	T12499T0012
			34	Bushing	T12551T0012
			35	Washer, Nylon (PA)	T12781T0012
			36	Latch Block, Aluminum	T13800T0012
			37	Spring, 302 Stainless steel	T13877T0012
			38	Plunger, Polyester	T12846T0012
			39	Cable	T12849T0012
			40	Screw, Carbon steel	1E175828982
			41	Bolt	T12980T0012
			42	Drive Screw, 18-8 Stainless steel (2 Required)	1A368228982
			43 ⁽¹⁾	Adaptor Plate, Zinc-plated steel	T12878T0012
			45 ⁽¹⁾	Cap Screw	1D617032992
			46 ⁽¹⁾	Nut (Not Shown)	T1022724122
			47	Handgrip	T12928T0012
			61	Spring, Mandrel	T13826T0012
			62	Spring, Torsion	T20973T0012
			63	Bolt, Alloy steel	T13803T0012
			64	Cap Screw, Carbon steel	GE25968X012
			65*	O-ring, Nitrile (NBR)	T1224006562

*Recommended spare part.

1. Applicable for Type N551-10 (NPS 1-1/4 FNPT) only.

LPG Equipment

Emerson Process Management Regulator Technologies, Inc.

USA - Headquarters
McKinney, Texas 75070 USA
Tel: +1 800 558 5853
Outside U.S.: +1 972 548 3574

For further information visit www.fisherregulators.com

The Emerson logo is a trademark and service mark of Emerson Electric Co. All other marks are the property of their prospective owners. Fisher is a mark owned by Fisher Controls International LLC, a business of Emerson Process Management.

The contents of this publication are presented for informational purposes only, and while every effort has been made to ensure their accuracy, they are not to be construed as warranties or guarantees, express or implied, regarding the products or services described herein or their use or applicability. We reserve the right to modify or improve the designs or specifications of such products at any time without notice.

Emerson Process Management Regulator Technologies, Inc. does not assume responsibility for the selection, use or maintenance of any product. Responsibility for proper selection, use and maintenance of any Emerson Process Management Regulator Technologies, Inc. product remains solely with the purchaser.