

Fisher™ 4320 Wireless Position Monitor

The Fisher 4320 eliminates the need for wiring to an on/off pneumatically actuated valve. It provides a precise wireless feedback signal to indicate equipment position with a percent (%) of span plus on/off indication. The 4320 can be used to control and/or monitor valves, sliding-stem regulators, displacement and float level sensors, and relief valves. It is designed to be simple to use, compact, and easily mounted.

The control portion of the 4320 accepts commands through the wireless network from a control system and provides a pneumatic on/off signal to an actuator. The feedback portion of the instrument periodically reads the position of a measured device and transmits that data over the wireless network. Transmitted data includes the percent of span value, limit switch status indications, valve set point, internal device temperatures, and power module voltage. It also checks for service and configuration instructions from host systems such as distributed control systems (DCS), asset management systems (AMS), and supervisory control and data acquisition (SCADA) systems.

The 4320 is normally powered by a battery sourced power module. This makes it easier to design new applications or implement into retrofit locations. An external power option is also available.

The 4320 uses a linkage-less feedback design that eliminates direct contact with the measured device (e.g., valve, regulator, level, louver, or other devices) eliminating physical contact and wear.

IEC 62591/ *WirelessHART*® communication protocol, operating at 2.4 Ghz, is utilized and is approved for use globally.



Instrument calibration and commissioning is performed with a push button and liquid crystal display (LCD) interface. This simplicity eliminates the need for tools or the setting of cams during set-up, saving you time.

Designed to meet intrinsically safe and non-incendive requirements, this instrument delivers scalable functionality in a small package. Due to the energy-limiting nature of the design, this intrinsically safe device is suitable for use in all zone locations. The battery sourced power module option has no cable conduits.

Specifications

Available Mountings

- Quarter-turn rotary-shaft,
- Sliding-stem, or
- Linear applications

Can also be mounted on other actuators that comply with IEC 60534-6-1, IEC 60534-6-2, VDI/VDE 3845 and NAMUR mounting standards.

Input Measurement (Valve or Process)

Stem Travel (linear movement)

Minimum: 2.5 mm (0.10 inch)

Maximum: 210 mm (8.25 inches)

Shaft Rotation (rotary movement)

Minimum: 45°

Maximum: 90°

Shaft Rotation (rotary movement, arced array)

Minimum: 13°

Maximum: 30°

Measurement Output

Analog: 0-100%

Discrete: on/off switches (2)

Reference Accuracy

Standard: 1% of span

Optional: 0.4% of span

On/Off Control

Output Signal

Pneumatic signal as required by the actuator, up to 95% of supply pressure

Minimum Span: 3.1 bar (45 psig)

Maximum Span: 7 bar (101 psig)

Action: Single or Double Acting

Supply Pressure

Minimum: 3.1 bar (45 psig)

Maximum: 7 bar (101 psig)

Supply Medium

Air or Natural Gas

Supply medium must be clean, dry, and non-corrosive. The supply air at the device should have a dew point less than -20°C (-4°F).

Per ISA Standard 7.0.01

A maximum 40 micrometer particle size in the air system is acceptable. Further filtration down to 5 micrometer particle size is recommended.

Lubricant content is not to exceed 1 ppm weight (w/w) or volume (v/v) basis. Condensation in the air supply should be minimized.

Per ISO 8573-1

Maximum particle density size: Class 7

Oil content: Class 3

Pressure Dew Point: Class 3 or at least 10°C less than the lowest ambient temperature expected

Air Consumption⁽¹⁾

At 5.5 bar (80 psig) supply pressure:

Maximum At 20°C: 615 cm³/min (1.30 scfh)

Maximum At -20°C: 1415 cm³/min (3.00 scfh)

Air Capacity / Flow Rate

Supply Pressure: 1.2 Cv

Connections (Optional)

Supply, Output Pressure, and Vent: 1/4 NPT

Wireless Set Point Command

IEC 62591 (*WirelessHART*) 2.4 GHz DSSS

Local User Interface

Liquid Crystal Display (LCD)

Two pushbuttons for navigation, setup, and calibration

Communication Protocol

HART 7 and IEC 62591 (*WirelessHART*)

Maintenance Port Communication Signal

Bell 202 Voltage Signaling: 1200 bps binary phase-continuous Frequency-Shift-Keying (1220 Hz mark, 2400 Hz space) superimposed on voltage level

Initial Dynamic Variable Assignments (Default)

Dynamic Variable Assignment	DEVICE STRUCTURE		
	Control	Snap Control	Monitor
Primary (PV)	Position	Position	Position
Secondary (SV)	Set Point	Set Point	Switch States
Tertiary (TV)	Switch States	Switch States	Cycle Counter
Quaternary (QV)	Supply Voltage	Supply Voltage	Supply Voltage

-continued-

Specifications (continued)

Wireless Communication Signal

2.4 Ghz, DSSS, IEC 62591 (*WirelessHART*)
Maximum 10 dBm (10 mW) EIRP at 2.46 GHz

Wireless Classifications

Class A digital device, complies with part 15 of the FCC Rules
Contains FCC ID: LW2-RM5800
Contains IC: 2731A-RM5800

Electromagnetic Compatibility

Meets EN 61326-1:2013
Immunity—Industrial locations per Table 2 of the EN 61326-1 standard
Emissions—Class A & B
ISM equipment rating: Group 1, Class A & B

Vibration Testing

Meets or exceeds vibration levels specified in ANSI/ISA 75.13.01 1996 (2007):
4 mm peak to peak at 5 Hz,
2 g from 15-150 Hz, and
1 g from 150- 2000 Hz

European Directive Information

This product complies with the following directives:

- ATEX Directive (2014/34/EU)*
- Electro Magnetic Compatibility (EMC) (2014/30/EU)*
- Radio Equipment Directive (RED) (2014/53/EU)*
- Pressure Equipment Directive (PED) (2014/68/EU)*
- Reduction of Hazardous Substances (RoHS) (2011/65/EU)*

Refer to Safety Instructions ([D103022X012](#)) for the Declaration of Conformity

Operating Temperature Limits⁽²⁾⁽³⁾

Monitoring

Battery Power: -40 to 85°C (-40 to 185°F)
External Power: -40 to 80°C (-40 to 176°F)
LCD may not be readable below -20°C (-4°F)

With Pneumatic Output (On/Off Control Option):
-20 to 50°C (-4 to 122°F)

Temperature Sensitivity

0.06% change per degree C

Storage Temperature Limits⁽²⁾

-40 to 70°C (-40 to 158°F)

Humidity Limits

10-95% Non-Condensing Relative Humidity

Electrical Classification

CSA (C/US)—Intrinsically Safe
ATEX—Intrinsically Safe
IECEX—Intrinsically Safe

Electrical Housing

Type 4X, IP66 & IP67

Other Classifications/Certifications

CML—Certification Management Limited (Japan)
CUTR—Customs Union Technical Regulations (Russia, Kazakhstan, Belarus, and Armenia)
ESMA—Emirates Authority for Standardization and Metrology - ECAS-Ex (UAE)
INMETRO—National Institute of Metrology, Quality and Technology (Brazil)
INTERTEK—British multinational assurance, inspection, product testing and certification company headquartered in London, England
NEPSI—National Supervision and Inspection Centre for Explosion Protection and Safety of Instrumentation (China)
PESO CCOE—Petroleum and Explosives Safety Organisation - Chief Controller of Explosives (India)
Contact your [Emerson sales office](#) for classification/certification specific information

-continued-

Table of Contents

Features	5	Setup/Installation	6
Integration	6	Battery Sourced Power Module Life	6
Principle of Operation	6	Ordering Information	7

Specifications (continued)

IEC 61010 Compliance

Meets Pollution Degree 4

Adjustments

Zero and Maximum Span through local interface

Dimensions

See figure 1, 2, and 3

Weight

Monitoring: 0.57 kg (1.25 lbs)

On/Off Control: 1.96 kg (4.3 lb)

Power Module⁽³⁾

Standard—Lithium (non-rechargeable)

Power Module Limits⁽⁴⁾

Standard— 5 years at update rate of 16 seconds or longer with 3 additional devices communicating through it

Extended-Life— 10 years at update rate of 8 seconds or longer with 3 additional devices communicating through it

Shelf life—10 years (radio off)

External Power (Optional)

12 - 28 volts DC

100 mA maximum operating current

Polarity Insensitive

Wire Size— 14-20 gauge

Update Rates

For position feedback, temperature, and power module voltage—selectable from 1 second to 1 hour; 1s, 2s, 4s, 8s, 16s, 32s, 1 to 60 minutes

Note: Sample rate for position feedback is normally the same as the update rate.

Construction Material

Housing: A03600 low copper aluminum alloy

Elastomers: nitrile, fluorosilicone

1. Normal m3/hour - Normal cubic meters per hour at 0°C and 1.01325 bar, absolute. Scfh - Standard cubic feet per hour at 60°F and 14.7 psia.

2. The temperature limits in this document and any applicable standard or code limitation for valve should not be exceeded.

3. Due to the combustible nature of the lithium content, the power module has special installation, operation, storage, and/or shipping requirements. Observe all warnings included with the power module before installing, operating, storing, or shipping. Contact your Emerson sales office if additional information is needed.

4. When operating in temperatures between -10°C (14°F) and -20°C (-4°F) it is recommended that you use the extended power module, as power module life is impacted. The life expectancy of an extended life power module used continually in the -10°C (14°F) and -20°C (-4°F) range is 3 years.

Features

- **Simplicity**—The 4320 is easy to use. The linkage-less feedback system is easy to install with a magnet array assembled to the valve stem. The 4320 has a local user interface that will allow you to calibrate the instrument. The full text display in the local interface is easy to navigate, in part due to the selection of languages.
- **Quick Installation**—Simply attach the 4320, calibrate and commission to any control system. With the pneumatic output option, only air is needed to automate an on/off valve. No conduit easements or permits are required with the standard or extended life power modules, thus saving time, costs, and effort in documenting cable runs and associated design reviews. Because there is no wiring, implementation times are shortened for device installation, setup, and commissioning.
- **Energy Efficiency**—The optional pneumatic output has ultra-low steady state air consumption. Air generation costs can be reduced.
- **Reliability**—The *WirelessHART* self-organizing mesh network provides the high level of communication reliability required in process control.
- **Power Options**—More than 5 years operation is typical using standard life and extended life power modules. Optional ability to use local 12-28 V power in the field.
- **Minimized Maintenance**—The feedback design provides more accurate monitoring and eliminates physical wear-out common in traditional valve instruments. This results in less frequent maintenance, repair, and re-calibration. Power modules can be easily replaced without losing power to the device, using the “hot swap” feature to maintain network reliability.
- **Diagnostics**—Predefined device, network, and system diagnostics provide details on the health of the device and its ability to communicate. Device diagnostics include whether the device calibration has been completed and power module health. The number of completed cycles is measured for the monitored equipment.

Note

A cycle is the change from open to closed position or vice versa. This is determined by moving past the trigger point in each direction.

- **Security**—The *WirelessHART* self-organizing mesh network includes encryption, authentication, and authorization mechanisms to provide the level of security required in process locations and by the Information Technology (IT) industry.

Integration

The 4320 is designed for use in most monitoring applications, replacing manual efforts to audit or verify equipment position. Examples include startup and shutdown situations, product changeover, product isolation, and sampling activities.

One implementation method can be accomplished using an overlay approach; adding wireless instrumentation on top of existing instrumentation. This preserves the existing infrastructure and enables improved information for operation, reactivity, maintenance, and safety.

A second approach is to replace older limit switches and position transmitters, either because of increased maintenance requirements or dated wiring infrastructure that has become or is believed to become an operational concern.

A third approach is to use the 4320 where feedback is not possible with standard wired options. For example, on rotating equipment, where the elimination of wires makes feedback possible.

The wireless nature of this device leads to its implementation in a wide range of systems, from programmable logic controllers (PLC), to DCS, AMS, and SCADA systems.

System integration for typical in-plant operations is available through a Smart Wireless Gateway.

Principle of Operation

Valve position is sensed through the non-contact, linkage-less feedback sensor. There are no moving linkages and the 4320 is physically separated from the valve or actuator through the use of a magnetic Hall effect sensor. A magnetic array is mounted to the valve or actuator stem and the sensor is embedded in the 4320 housing. The sensor is electrically connected to

the printed wiring board to provide a wireless travel feedback signal.

The control portion of the 4320 accepts commands through the wireless network from a control system and provides a pneumatic on/off signal to an actuator.

The internal electronics periodically reads the position of travel and transmits that data over the wireless network. The device also checks for instructions from host systems like DCS, SCADA and asset management systems. The device “sleeps” until the next reading, enabling longer power module life. The device is still powered up in the sleep mode but operating at ultra-low power consumption levels.

Setup/Installation

Device setup is typically performed prior to installation and includes setting two network parameters. These parameters are entered using a handheld such as the 475 Field Communicator. Calibration is performed after installation and requires using the local interface to place the device at the end points of travel range. The device is then ready for commissioning and service.

Battery Sourced Power Module Life

The 4320 uses power efficient measures to keep energy consumption to a minimum. However, there is a finite amount of energy within the power module. The life expectancy of the module is affected by two things; 1) the reporting rate, and 2) the number of devices in the network that must communicate through the 4320.

Typical on/off applications will operate effectively at one minute reporting periods.

Ordering Information

When ordering, specify:

1. Position monitor control

- Monitoring
- On/off control option

2. Power source

- Battery sourced power module
- External power option

3. Mounting requirements

Feedback sensor and mounting brackets are part of the mounting.

For rotary movement indicate if mounting requirements are:

- 90° NAMUR,
- 90° ISO mounting, or
- 30° for special applications

For linear movement, indicate travel length:

- 7 mm (1/4 inch),
- 19 mm (3/4 inch),
- 25 mm (1 inch),
- 38 mm (1-1/2 inch),
- 50 mm (2 inch),
- 110 mm (4-1/8 inch), or
- 210 mm (8-1/4 inch) strokes

Note

As a general rule, do not use less than 50% of the magnet assembly for full travel measurement. Performance will decrease as the assembly is increasingly subranged.

Contact your [Emerson sales office](#) if longer travel lengths are required.

Note

Contact your Emerson sales office if mounting on non-Emerson valves is required.

Figure 1. Dimensions

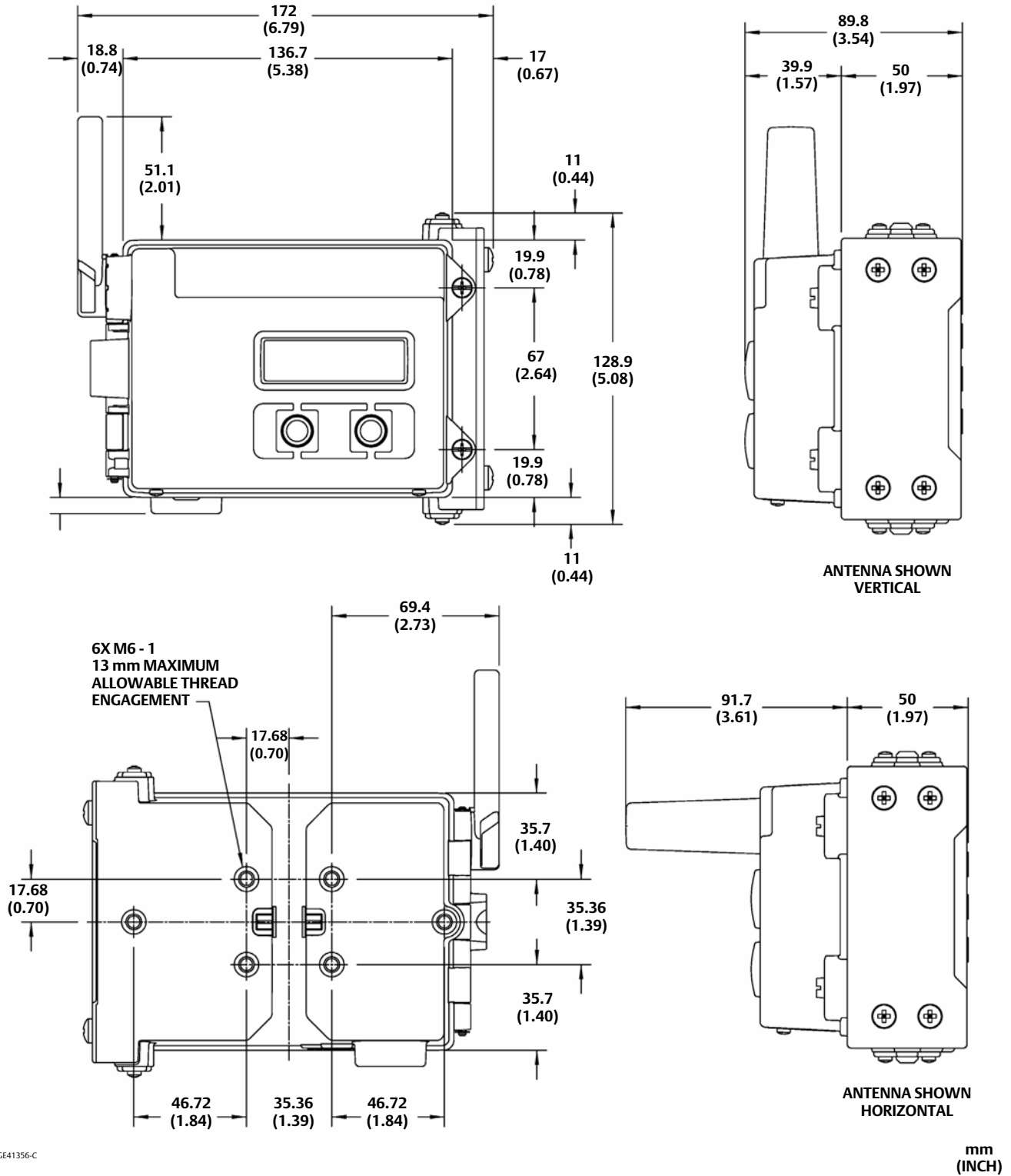

GE41356-C

Figure 2. Dimensions with On/Off Control Option

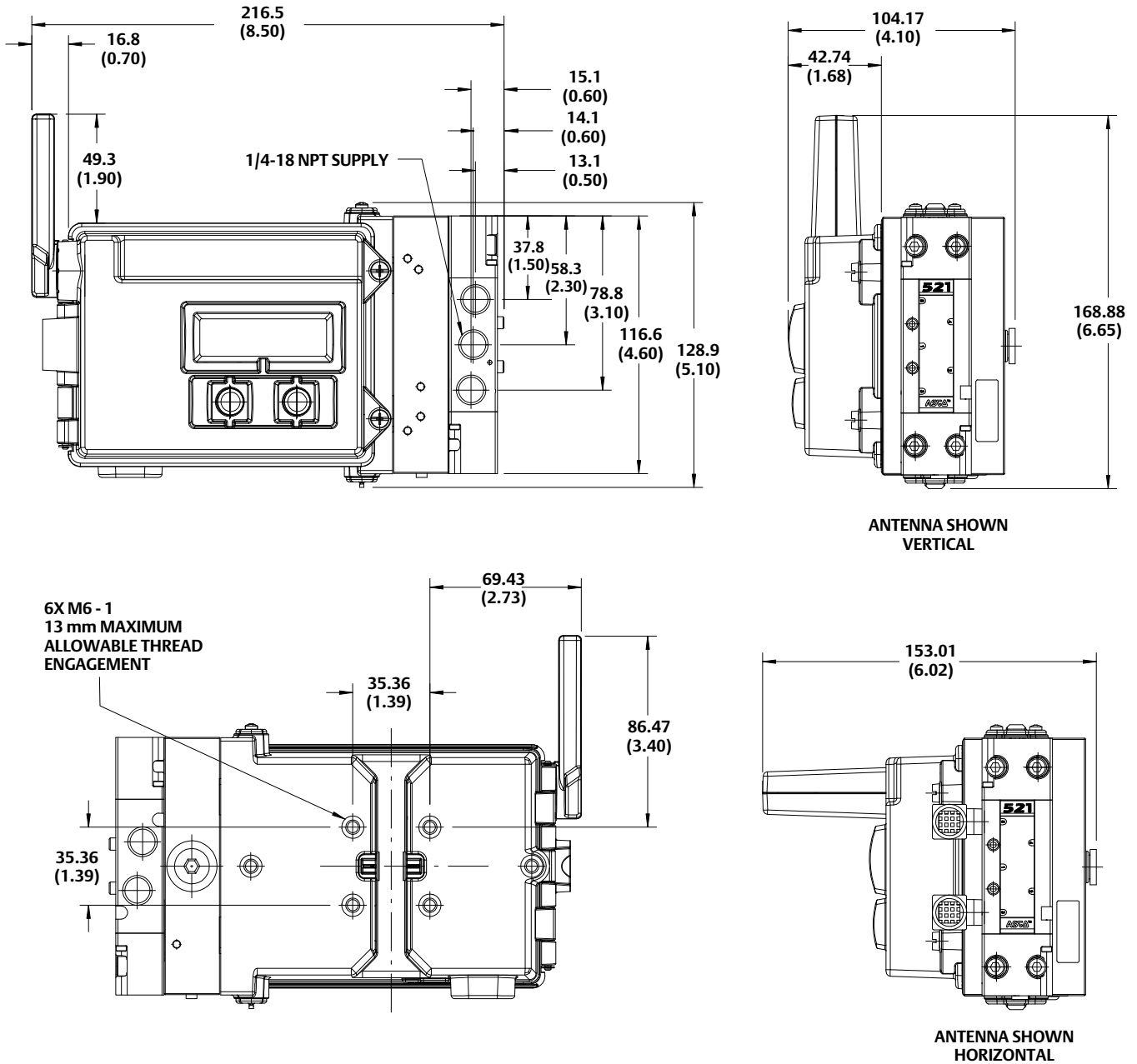

mm
(INCH)

Figure 3. Dimensions—External Power Option

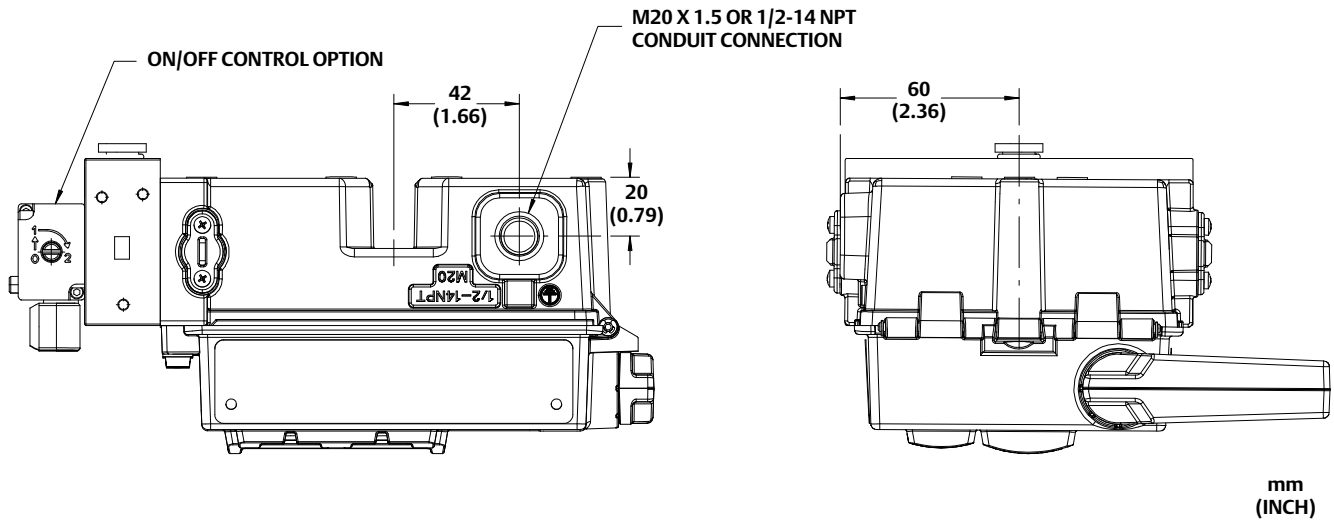

Neither Emerson, Emerson Automation Solutions, nor any of their affiliated entities assumes responsibility for the selection, use or maintenance of any product. Responsibility for proper selection, use, and maintenance of any product remains solely with the purchaser and end user.

Fisher is a mark owned by one of the companies in the Emerson Automation Solutions business unit of Emerson Electric Co. Emerson Automation Solutions, Emerson, and the Emerson logo are trademarks and service marks of Emerson Electric Co. HART and *WirelessHART* are registered trademarks of FieldComm Group. All other marks are the property of their respective owners.

The contents of this publication are presented for informational purposes only, and while every effort has been made to ensure their accuracy, they are not to be construed as warranties or guarantees, express or implied, regarding the products or services described herein or their use or applicability. All sales are governed by our terms and conditions, which are available upon request. We reserve the right to modify or improve the designs or specifications of such products at any time without notice.

Emerson Automation Solutions
Marshalltown, Iowa 50158 USA
Sorocaba, 18087 Brazil
Cernay 68700 France
Dubai, United Arab Emirates
Singapore 128461 Singapore

www.Fisher.com

