

Fisher™ 3710 and 3720 Positioners and 3722 Electro-Pneumatic Converter

Fisher 3710 pneumatic and 3720 electro-pneumatic positioners are part of the 3700 positioner series. They are designed for use with either diaphragm or piston rotary actuators. These positioners provide a valve ball or disk position for a specific input signal. The 3710 provides a valve position in response to a pneumatic input signal. The 3720 is created by the addition of a Fisher 3722 electro-pneumatic converter to the 3710 positioner. The positioner provides a valve position in response to a DC current input signal. Either type can easily be configured as single- or double- acting for rotary actuators.

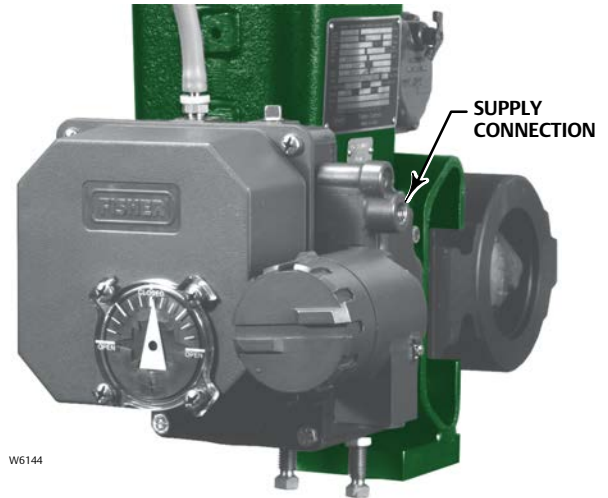

3720 POSITIONER
MOUNTED ON A 1052 ACTUATOR



3710 POSITIONER
MOUNTED ON A 1066 ACTUATOR

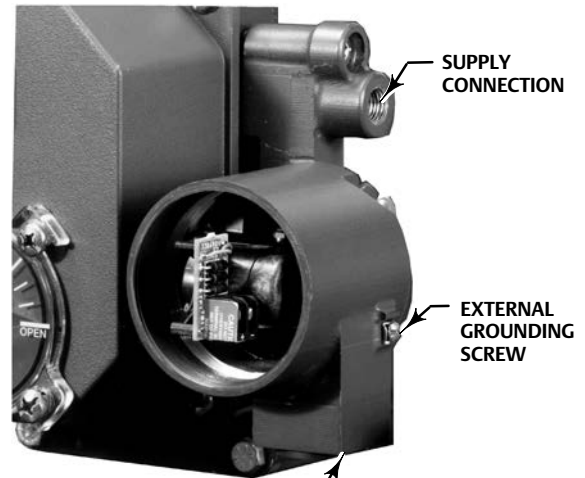

3722 ELECTRO-PNEUMATIC CONVERTER

Specifications

Available Configuration

The Fisher 3700 series of positioners include the following models:

3710: ■ Single- or ■ double-acting pneumatic rotary valve positioner

3720: ■ Single- or ■ double-acting electro-pneumatic rotary valve positioner consisting of a 3710 with a 3722 attached

3722: An electro-pneumatic converter that converts a 4-20 mA DC input signal to a 0.2 to 1.0 bar (3 to 15 psig) signal for the pneumatic positioner

Input Signal

3710:

Standard: ■ 0.2 to 1.0 bar (3 to 15 psig) or ■ 0.4 to 2.0 bar (6 to 30 psig)

Split-Range: ■ 0.2 to 0.6 bar (3 to 9 psig) and 0.6 to 1.0 bar (9 to 15 psig) or ■ 0.4 to 1.2 bar (6 to 18 psig) and 1.2 to 2.0 bar (18 to 30 psig)

3720:

Standard: ■ 4-20 mA DC constant current with 30 VDC maximum compliance voltage

Split-Range: ■ 4-12 mA DC or 12-20 mA DC

Equivalent Circuit

3720: 120 ohms shunted by three 5.6 V zener diodes

Output Signal

Pneumatic pressure as required by the actuator up to full supply pressure

Action⁽¹⁾: Field reversible between direct and reverse

Supply Pressure⁽²⁾

Minimum Recommended: 0.3 bar (5 psig) above actuator requirement

Maximum: 10.3 bar (150 psig) or maximum pressure rating of the actuator, whichever is lower

Supply Medium

3710: Air or Natural Gas

3720: Air

The 3720 positioner is not approved for use with Natural Gas as the supply medium

Steady-State Air Consumption⁽³⁾

3710:

6 mm Spool Valve: 0.82 normal m³/hr (29 scfh) at 4.1 bar (60 psig) supply pressure

3720:

6 mm Spool Valve: 1.0 normal m³/hr (36 scfh) at 4.1 bar (60 psig) supply pressure

Maximum Supply Air Demand⁽³⁾ (Double-Acting)

6 mm Spool Valve: 20 normal m³/hr (700 scfh) at 4.1 bar (60 psig) supply pressure

Typical Performance⁽⁴⁾

3710 Pneumatic Positioner

Independent Linearity: ±0.5% of output span

Hysteresis: 0.5% of output span

Deadband: 0.3% of input span

3720 Electro-Pneumatic Positioner

Independent Linearity: ±1.0% of output span

Hysteresis: 0.6% of output span

Deadband: 0.35% of input span

Electromagnetic Compatibility for 3722

electro-pneumatic converter:

Meets EN 61326-1:2013

Immunity—Industrial locations per Table 2 of the EN 61326-1 standard. Performance is shown in table 1 below.

Emissions—Class A

ISM equipment rating: Group 1, Class A

Note: Electromagnetic Compatibility specifications also apply to the 3720 positioner

Operating Influences

Supply Pressure Sensitivity: A 10% change in supply pressure changes the valve shaft position less than the following percentages of valve rotation:

3710: 1.0% at 4.1 bar (60 psig) supply pressure

3720: 1.5% at 4.1 bar (60 psig) supply pressure

Operative Temperature Limits⁽²⁾

■ -40 to 80°C (-40 to 180°F),

■ -50 to 107°C (-58 to 225°F)

Construction Materials

Positioner Base: Low copper aluminum alloy

Cover: Polyester plastic

Feedback Shaft: Stainless steel

Range Spring: Stainless steel

Input Module Diaphragm, O-rings: ■ Nitrile or

■ Ethylene-propylene (EPDM)

Spool Valve: SST/C72900

Tubing: Copper (standard)

-continued-

Specifications (Continued)

Construction Materials (continued)

Fittings: Brass (standard)
Gauges: Chrome-plated brass connection with plastic case
Connectors for diagnostic testing: ■ Stainless steel or ■ Brass

Electrical Classifications for 3722 Converter

CSA—Intrinsically Safe, Explosion-proof, Type n, Dust-Ignition Proof

FM—Intrinsically Safe, Explosion-proof, Type n, Non-incendive, Dust-Ignition Proof

ATEX—Intrinsically Safe, Flameproof, Type n

IECEx—Intrinsically Safe, Flameproof, Type n

Note: These classifications also apply to the 3720 positioner

Housing Classification for 3722 Converter

CSA— Type 3 Encl. ATEX— IP64

FM— NEMA 3, IP54 IECEx— IP54

Mount instrument with vent on side or bottom if weatherproofing is a concern

Note: These classifications also apply to the 3720 positioner

Other Classifications/Certifications for 3722 Converter

CUTR— Customs Union Technical Regulations (Russia, Kazakhstan, Belarus, and Armenia)

INMETRO—National Institute of Metrology, Quality and Technology (Brazil)

KGS—Korea Gas Safety Corporation (South Korea)

Contact your [Emerson sales office](#) for classification/certification specific information

Note: This classification also applies to the 3720 positioner

Hazardous Area Classification for 3710 Positioner

Complies with the requirements of ATEX Group II Category 2 Gas and Dust

 Ex h IIC Tx Gb
Ex h IIIC Tx Db

Maximum surface temperature (Tx) depends on operating conditions

Gas: T4, T5, T6
Dust: T85...T107

Meets Customs Union technical regulation TP TC 012/2011 for Groups II/III Category 2 equipment

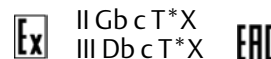

Note: These ratings do *not* apply to the 3720 positioner

Pressure Connections

1/4 NPT internal

Electrical Connection for 3720 Positioner

1/2-14 NPT conduit connection

Rotary Valve Rotation

■ 90 degrees (standard) ■ 60 degrees (optional)

Options

Span Adjuster Assembly: ■ 0.2 to 1.0 bar (3 to 15 psig) input range or, ■ 0.4 to 2.0 bar (6 to 30 psig) input range

Elastomers (O-rings, diaphragm): ■ standard temperature range, -40 to 80°C (-40 to 180°F), ■ extended temperature range -50 to 107°C (-58 to 225°F)

■ Special applications, ■ Beacon indicator, ■ Gauges⁽⁵⁾, tire valves, or connectors for diagnostic testing

Approximate Weight

3710: 2.04 kg (4.5 pounds)
3720: 2.72 kg (6.0 pounds)

NOTE: Specialized instrument terms are defined in ANSI/ISA Standard 51.1 - Process Instrument Terminology.

1. Direct-acting, an increasing input signal extends actuator rod. Reverse-acting, an increasing input signal retracts actuator rod.

2. The pressure and temperature limits in this document and any applicable standard or code limitation should not be exceeded.

3. Normal m³/hr—Normal cubic meters per hour (0°C and 1.01325 bar, absolute); Scfh—Standard cubic feet per hour (60°F and 14.7 psia).

4. Typical values determined by tests with a 1061 size 30 actuator at 4.1 bar (60 psig) supply pressure. Performance may vary with other actuator types and supply pressures.

5. Gauges not available for high temperature range.

Table 1. Fisher 3722 Electro-Pneumatic Converter⁽¹⁾ EMC Summary Results—Immunity

Port	Phenomenon	Basic Standard	Test Level	Performance Criteria ⁽²⁾
Enclosure	Electrostatic Discharge (ESD)	IEC 61000-4-2	4 kV contact; 8 kV air	A
	Radiated EM field	IEC 61000-4-3	80 to 1000 MHz @ 10V/m with 1 kHz AM at 80% 1400 to 2000 MHz @ 3V/m with 1 kHz AM at 80% 2000 to 2700 MHz @ 1V/m with 1 kHz AM at 80%	A
	Rated power frequency magnetic field	IEC 61000-4-8	60 A/m at 50 Hz	A
I/O signal/control	Burst (fast transients)	IEC 61000-4-4	1 kV	A
	Surge	IEC 61000-4-5	1 kV (line to ground only)	B
	Conducted RF	IEC 61000-4-6	150 kHz to 80 MHz at 3 volts	A
Specification limit = ±1% of span 1. The information contained in the table also applies to the 3720 positioner. 2. A = No degradation during testing. B = Temporary degradation during testing, but is self-recovering.				

Features

- **Accurate, Fast Response**—3710 and 3720 positioners use field-proven spool valve technology for a simple design that gives accurate, fast-responding operation with high cycle life. These positioners are able to withstand the severe vibrations of most plant environments.
- **Modular Construction**—The 3710 positioner converts easily to a 3720 positioner by adding the 3722 electro-pneumatic converter. The converter mounts over the instrument and supply ports in the 3710 positioner base. This provides a simple, compact, and cost-effective field conversion from pneumatic to electro-pneumatic valve positioning.
- **Corrosion-Resistant Construction with Air Purge**—Case, components, and gasket materials withstand harsh environments. Proven engineered resins and 300 Series stainless steel construction is used throughout each unit. Die castings are low copper aluminum alloy to maximize corrosion resistance. Positioner bleed air purges internal positioner parts. As an option with some Fisher actuators, bleed air also purges the actuator housing for additional protection.
- **Extended Temperature Capability**—With EPDM O-rings and input module diaphragm, 3710 and 3720 positioners can be used in low-temperature and high-temperature applications.
- **Meets Special Application Requirements**—3710 and 3720 positioners with EPDM O-rings and input module diaphragm can be used in applications with special material requirements as in the food and beverage industry, pharmaceuticals, and tobacco processing.
- **Easy Positioner Adjustments**—With the cover removed (figure 1), all internal components are easily accessed. Zero and span adjustments are made by hand with no tools required.
- **Stable Operation**—Changes in supply pressure and ambient temperature have minimal effect on positioner operation.
- **Control Valve Diagnostic Testing Capability**—To support diagnostic testing of valve/actuator/positioner packages, connectors, piping, and other hardware can be installed between the 3710 positioner and the actuator. A typical connector installation is shown in figure 5.
- **Valve Position Indicator**—Standard, low-profile indicator or optional, beacon-style indicator mount easily to the positioner cover.

Figure 1. Features and Adjustments

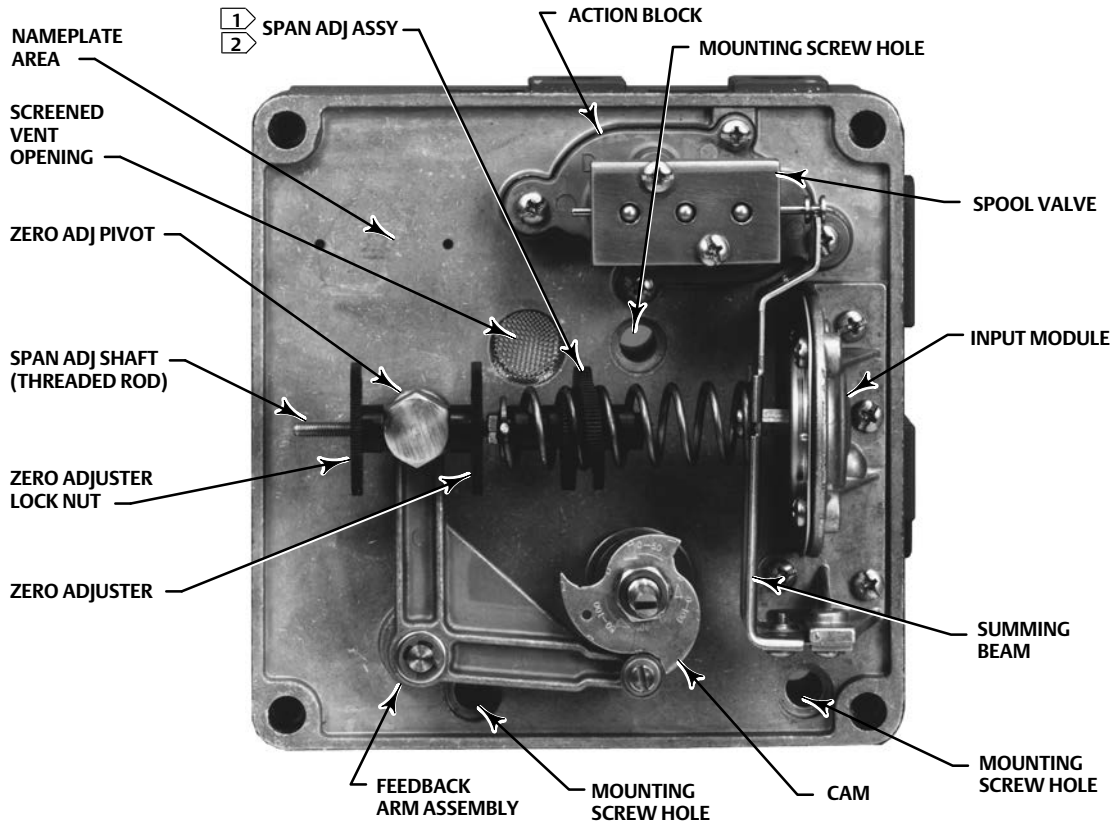

Notes:

- 1 The Span Adj Assy is made up of the range spring, span adj shaft (threaded rod) and span adj knob.
- 2 The Span Adj Assy features a red color-coded range spring for a 0.4 to 2.0 bar (6 to 30 psig) input signal.

W5947

Actuators

The positioner mounts integrally to the actuator cover plate (figure 2) of the following Fisher actuators:

- 1051 and 1052, size 30: The size 30 actuator is no longer manufactured by Emerson. The 3710 positioner is available for field installation on existing size 30 actuators.
- 1051, size 40 and 60
- 1052, size 40, 60, and 70
- 1061, size 30, 40, 60, and 68
- 1051, size 33
- 1052, size 20, 33
- 1061, size 80, 100
- 1066, size 20, 27, and 75
- 2052, size 1, 2, and 3
- NAMUR Mounting

A mounting plate is used to mount the 3710 positioner to the following Fisher actuators:

Figure 2. Mounting the Positioner Base Plate

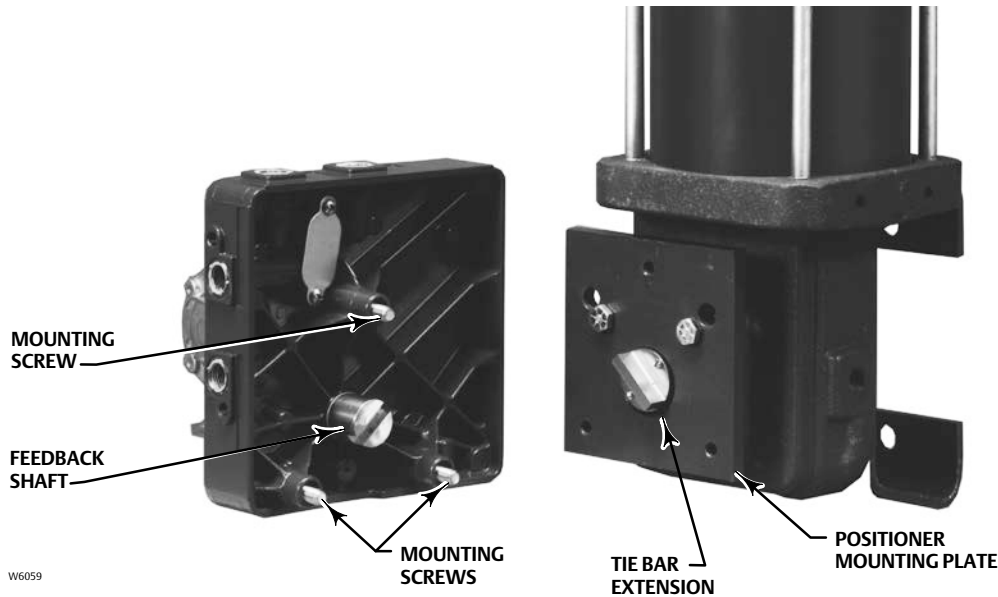

Principle of Operation

Refer to the positioner schematic (figure 3). The operational description here follows the schematic layout and orientation.

The 3710 pneumatic positioner is a force-balance instrument that provides a control valve position proportional to a pneumatic input signal. The balance of opposing forces in the positioner occurs at the summing beam.

One force applied to the summing beam is developed from the input signal pressure on the diaphragm. The other force is from the feedback spring and is proportional to the position of the feedback lever.

When the input pressure is increased to the diaphragm of the input module, the diaphragm strokes down, increasing the effective force from the input module and compressing the feedback spring. The summing beam moves the spool down in the spool body, opening output port B to supply air to the left side of the actuator. At the same time, output port A of the spool valve opens, allowing the right side of the actuator to vent to atmosphere.

The piston in the actuator moves to the right, rotating the feedback shaft and cam counterclockwise. This rotation causes the feedback lever to rotate clockwise, increasing the compression on the feedback spring. These rotations continue until the additional force from the spring balances with the input module force on the summing beam. When the forces are equal, the summing beam returns to its steady state or neutral position and the actuator is held at a new position.

In a 3720 positioner, the 3722 converter receives the milliamper (mA), direct current (DC), input signal and provides a proportional pneumatic output signal through a nozzle/flapper arrangement. Nozzle pressure from the converter module travels through the converter housing to provide the input signal pressure to the 3710 pneumatic positioner.

The feedback lever position is determined by the location or rise of the cam (figure 4) which is attached to the feedback shaft. When the two opposing forces are equal or at a steady state, the summing beam holds the spool in a neutral position. At steady state, a small flow of air passes from supply through both outputs of the spool valve to the actuator, holding the actuator at a constant position. At the same time, another small flow of air exhausts out each end of the spool valve.

Figure 3. Fisher 3710 Positioner Schematic

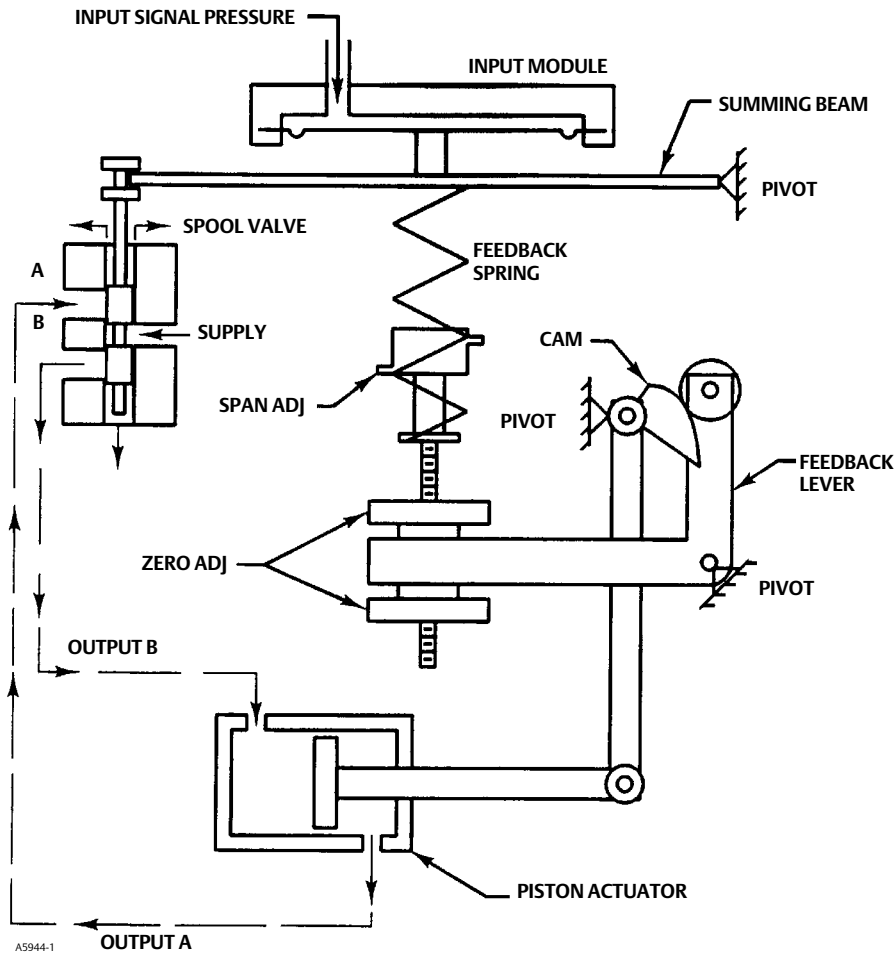
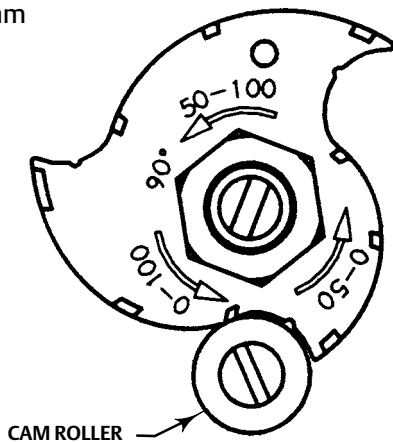

Figure 4. Cam



A6045

Installation

The supply pressure medium must be a clean, dry, filtered air, or noncorrosive gas (3710 positioner only). If the supply source is capable of exceeding the maximum actuator operating pressure or positioner supply pressure, take appropriate steps during installation to protect the positioner and all connected equipment against overpressure.

Positioner connections including connections for diagnostic testing and overall dimensions are shown in figure 5.

Figure 5. Dimensions and Connections

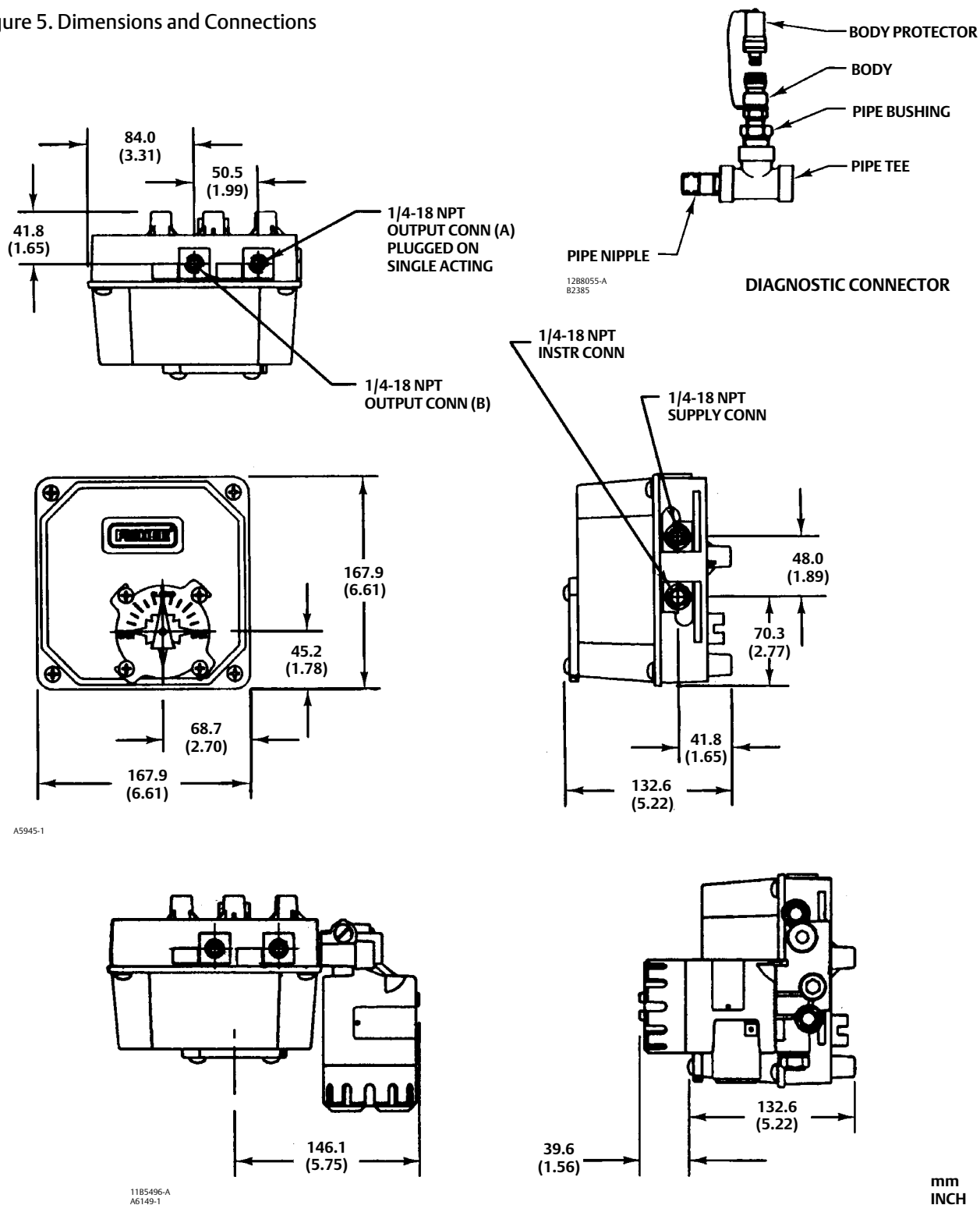

Ordering Information

When ordering, specify:

Required Application Information

1. Positioner type number
2. Pneumatic or DC current input signal range
3. Direct- or reverse-acting
4. Actuator type, size, and degrees of rotation
5. Maximum supply pressure available

6. Ambient temperature range
7. Special application material requirements such as EPDM elastomers
8. Supply pressure regulator and options such as gauges or tire valves, if required
9. Connectors for diagnostic testing, if required

Construction Specifications

Refer to the construction details given in the Specifications. If different materials of construction are required, contact your [Emerson sales office](#).

Neither Emerson, Emerson Automation Solutions, nor any of their affiliated entities assumes responsibility for the selection, use or maintenance of any product. Responsibility for proper selection, use, and maintenance of any product remains solely with the purchaser and end user.

Fisher is a mark owned by one of the companies in the Emerson Automation Solutions business unit of Emerson Electric Co. Emerson Automation Solutions, Emerson, and the Emerson logo are trademarks and service marks of Emerson Electric Co. All other marks are the property of their respective owners.

The contents of this publication are presented for informational purposes only, and while every effort has been made to ensure their accuracy, they are not to be construed as warranties or guarantees, express or implied, regarding the products or services described herein or their use or applicability. All sales are governed by our terms and conditions, which are available upon request. We reserve the right to modify or improve the designs or specifications of such products at any time without notice.

Emerson Automation Solutions
Marshalltown, Iowa 50158 USA
Sorocaba, 18087 Brazil
Cernay 68700 France
Dubai, United Arab Emirates
Singapore 128461 Singapore

www.Fisher.com

