

Data sheet

Check & stop valve, SCA-X

Check valve, CHV-X



SCA-X are check valves with a built-in shut-off valve function. SCA-X valves are available in angleway versions.

CHV-X are check valves only. CHV-X are available in both angleway and straightway versions.

The valves are designed to open at very low differential pressures, allow favourable flow conditions and are easy to disassemble for inspection and service.

The SCA-X is equipped with vented cap and has internal backseating enabling the spindle seal to be replaced whilst the valve still under pressure.

Laser cut V-ports provide excellent opening characteristics (SCA-X/CHV-X 50-125).

The valve cone has a built-in flexibility to ensure a precise and tight closing towards the valve seat.

A well balanced dampening effect between the piston and the cylinder gives an optimal protection during low loads and against pulsations.

Features

- Applicable to HCFC, HFC, R717 (Ammonia), R744 (CO₂), Propane, Butane, Iso-Butane and Ethane.
R717 Heat Pump and Propylene applications with replaced O-ring.
- Modular Concept:
 - Each valve housing is available with several different connection types and sizes.
 - Possible to convert SCA-X or CHV-X to any other product in the Flexline™ SVL family (Hand operated regulating valve, shut-off valve or strainer) just by replacing the complete top part.
- Fast and easy valve overhaul service. It is easy to replace the top part and no welding is needed.
- Designed to open at a very low differential pressure of 0.04 bar / 0.58 psig.
- Designed with a built-in damping chamber preventing valve flutter in case of low refrigerant velocity and/or low density.
- Each valve is clearly marked with type, size and performance range.
Additional ID ring to be installed when preparing for Ammonia Heat Pump or Propylene application.
- Easy to disassemble for inspection and service.
- Internal backseating enables replacement of the spindle seal whilst the valve is active, i.e. under pressure.
- Optimal flow characteristics ensuring quick opening to the fully open position.
- Protection against pulsation by built-in damping facility.
- Housing and bonnet material is low temperature steel according to requirements of the Pressure Equipment Directive and other international classification authorities.
- Equipped with Stainless steel bolts.
- Max. working pressure: 52 bar g / 754 psi g
- Temperature range: -60 – 150 °C / -76 – 302 °F
- Classification: DNV, CRN, BV, EAC etc.
To get an updated list of certification on the products please contact your local Danfoss Sales Company.

Design

Connections

Available with the following connections:

- Butt-weld DIN (EN 10220)
DN 15 - 125 (½ - 5 in.)
- Butt-weld ANSI (B 36.10 Schedule 80),
DN 15 - 40 (½ - 1½ in.)
- Butt-weld ANSI (B 36.10 Schedule 40),
DN 50 - 125 (2 - 5 in.)
- Butt-weld GOST, (8734-75 and 8732-78)
DN 15 - 125 (½ - 5 in.)
- Socket-weld ANSI (B 16.11),
DN 50 (2 in.)

Housing

The housing is made from special, cold resistant steel.

Valve cone

Valve cone with built in metallic stop - prevents damage to teflon ring in case of overtightening.

Damping chamber

The chamber is filled with refrigerants (gas or liquid), which provides a damping effect when the valve opens and closes.

Spindle (SCA-X)

Made of polished stainless steel, which is ideal for O-ring sealing.

Packing Gland (SCA-X)

The “full temperature range” packing gland is the standard for the entire SVL platform.

This ensures perfect tightness throughout the whole temperature range:
-60 – 150 °C / -76 – 302 °F.

Pressure Equipment Directive (PED)

The SCA-X/CHV-X valves are approved according to the European standard specified in the Pressure Equipment Directive and are CE marked.

For further details / restrictions - see the product instruction.

Installation

The valve must be mounted vertically with the cone downwards.

The valve is designed to resist very high internal pressure. However, the piping system in general should be designed to avoid liquid traps and reduce the risk of hydraulic pressure caused by thermal expansion.

For further information refer to installation instructions for SCA-X/CHV-X.

If cold refrigeration oil having low viscosity enters and settles in the damping chamber, problems with the check valve may arise. Consequently, it may be necessary to modify the valve for more viscous liquids by enlarging the hole to the damping chamber.

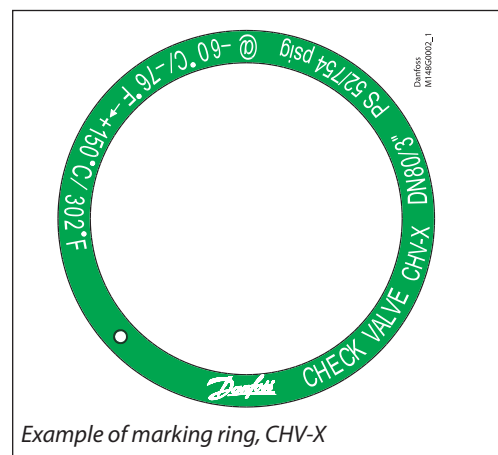

SCA-X/CHV-X valves			
Nominal bore	DN = < 25 mm (1 in.)	DN32-80 mm (1¼ - 3 in.)	DN100 - 125 mm (4 - 5 in.)
Classified for	Fluid group I		
Category	Article 3, paragraph 3	II	III

Application

Figure 3 shows the check & stop valve SCA-X in the discharge line of a screw compressor unit. The SCA-X valve in the discharge line prevents “back condensation” in the oil separator as well as pressure equalising through the compressor.

Compared to an ordinary shut-off and check valve arrangement the combined check & stop valve solution, as shown, is easier to install and has lower flow resistance.

Installation of the SCA-X/CHV-X in the economizer line is **not** recommended.

For horizontal installation of the function module; please contact Danfoss.

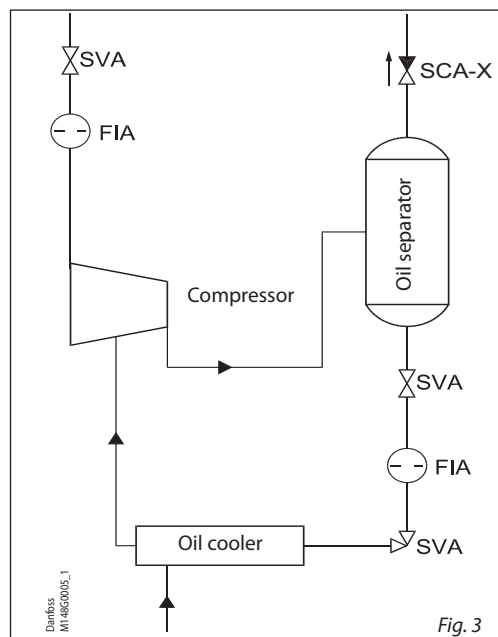

Technical data

- **Refrigerants**
Applicable to HCFC, HFC, R717 (Ammonia), R744 (CO₂), Propane, Butane, Iso-Butane and Ethane.
R717 Heat Pump and Propylene applications with replaced O-ring.
- **Temperature range**
-60 – 150 °C / -76 – 302 °F.
- **Max. working pressure**
52 bar g / 754 psig.

Computation and selection

Introduction

When dimensioning SCA-X/CHV-X, it is important to select a valve that is best suited to all operating conditions. Therefore, it is necessary to consider both the nominal and part load working conditions.

The SCA-X/CHV-X valve can be calculated in two ways:

- Using the tables below.
- Using Coolselector®2

Example

SI-Units

Assumed working conditions:
Maximum flow $\dot{V} = 1000 \text{ m}^3/\text{h}$
Density $\rho = 3.0 \text{ kg/m}^3$
Minimum part load = 33%

US-Units

Assumed working conditions:
Maximum flow $\dot{V} = 1160 \text{ gpm}$
Density $\rho = 0.187 \text{ lb/feet}^3$
Minimum part load = 33%

Used expressions:

- Recommended velocity - C_{rec} [m/s]
- Minimum recommended velocity - $C_{min, rec}$ [m/s]
- Maximum velocity - C_{max} [m/s]
- Part load velocity - C_{part} [m/s]

Used expressions:

- Recommended velocity - C_{rec} [ft/min]
- Minimum recommended velocity - $C_{min, rec}$ [ft/min]
- Maximum velocity - C_{max} [ft/min]
- Part load velocity - C_{part} [ft/min]

We know the density $\rho \approx 3.0 \text{ kg/m}^3$, consequently C_{rec} as well as $C_{min, rec}$ can be found in the figure below (standard valve).

We know the density $\rho \approx 0.187 \text{ lb/feet}^3$, consequently C_{rec} as well as $C_{min, rec}$ can be found in the figure (standard valve).

$C_{rec} \approx 14 \text{ m/s}$
 $C_{min, rec} \approx 3 \text{ m/s}$

$C_{rec} \approx 2756 \text{ ft/min}$
 $C_{min, rec} \approx 591 \text{ ft/min}$

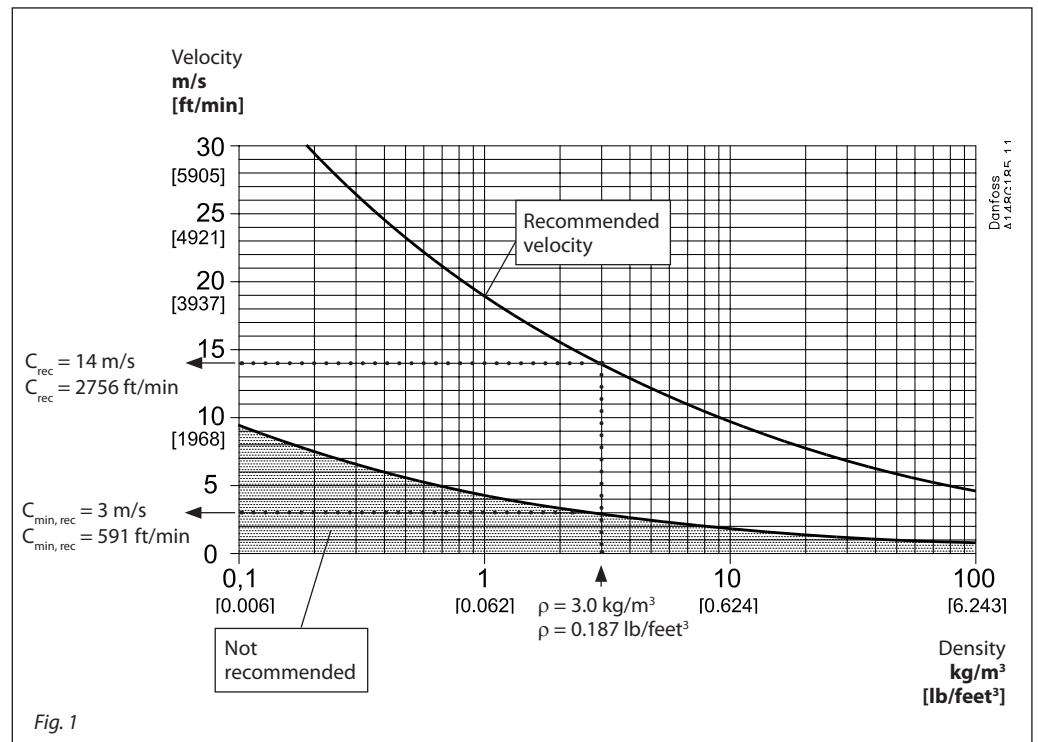

Selection example continued on following page.

Computation and selection
(continued)

Knowing that $\dot{V} = 1000 \text{ m}^3/\text{h}$ (1160 gpm) fig. 2 gives the following choices:

- For SCA-X/CHV-X in size DN 100 the maximum velocity $C_{\text{max}} \approx 31 \text{ m/s}$ (6100 ft/min)
- For SCA-X/CHV-X in size DN 125 the maximum velocity $C_{\text{max}} \approx 20 \text{ m/s}$ (3900 ft/min)

In conclusion SCA-X in size DN 125 is selected because $C_{\text{max}} \approx 20 \text{ m/s}$ (3900 ft/min) comes nearest to the recommended velocity $C_{\text{rec}} \approx 14 \text{ m/s}$ (2756 ft/min) and at the same time part load conditions fulfil the requirements, as described:

If the valve in question (for instance under part load conditions) provides a velocity less than $C_{\text{min,rec}}$ the valve might start hammering and become noisy. As a result the valve may wear prematurely.

We know that $C_{\text{max}} \approx 20 \text{ m/s}$ (3900 ft/min) and that minimum part load is 33%. It follows that $C_{\text{part}} \approx 6.5 \text{ m/s}$ (1290 ft/min). Thus, $C_{\text{part}} (6.5 \text{ m/s}) > C_{\text{min,rec}} (3.0 \text{ m/s})$ and the selected SCA-X model DN125 is the perfect choice.

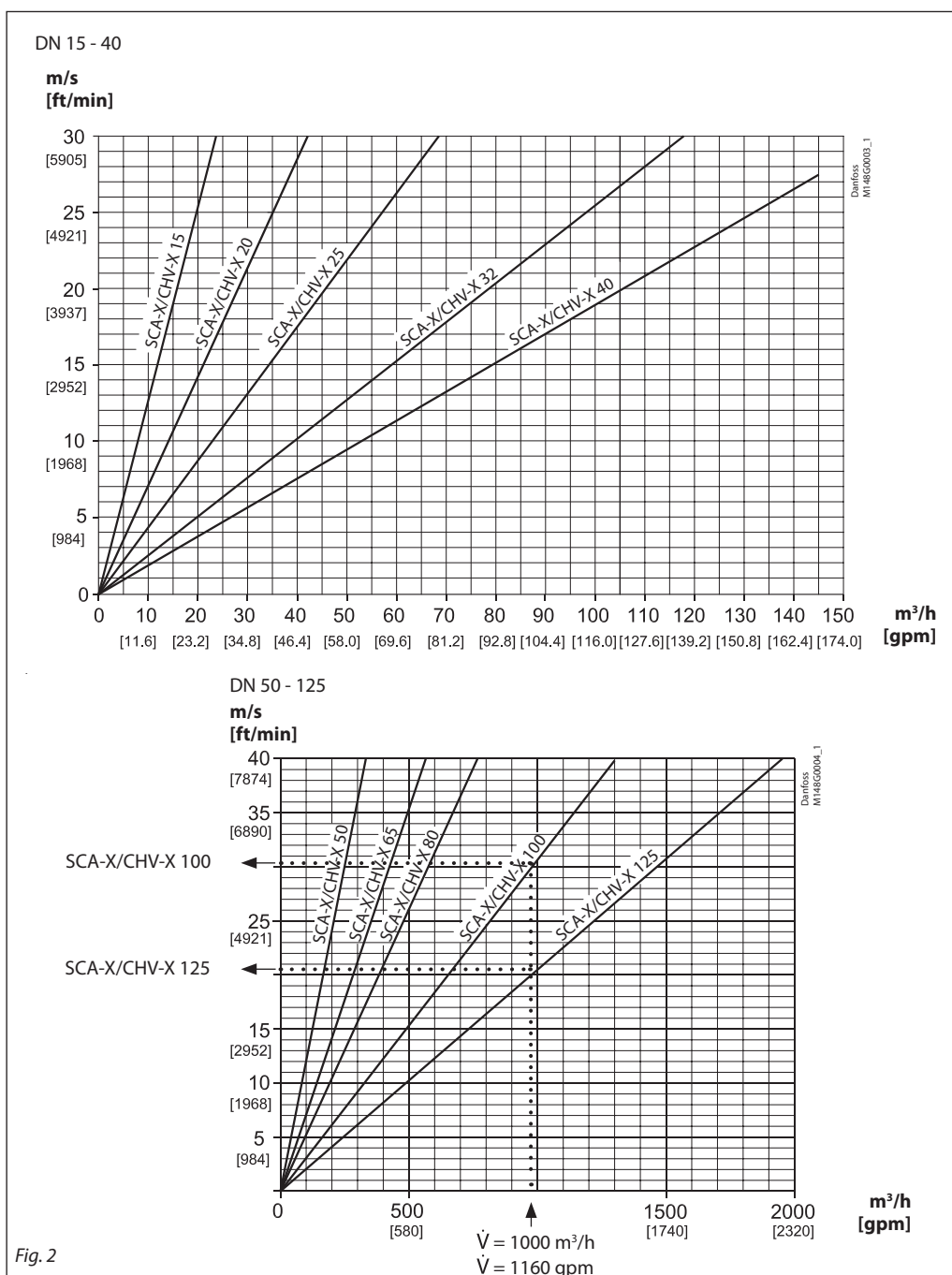
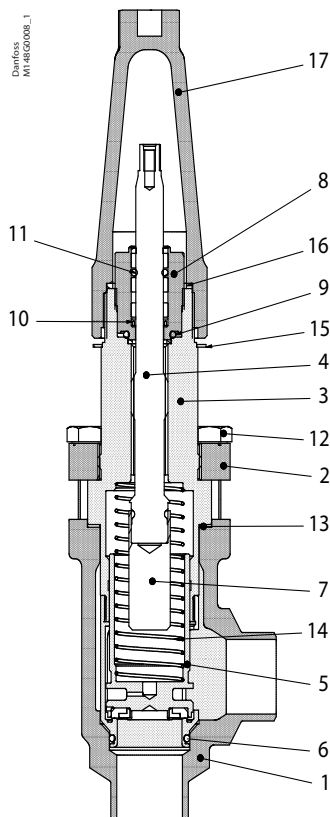
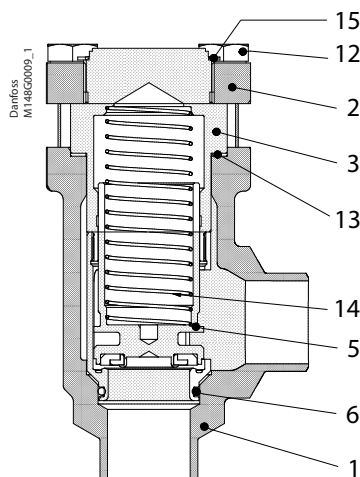

Fig. 2

Material specification



SCA-X 15 - 40



CHV-X 15 - 40

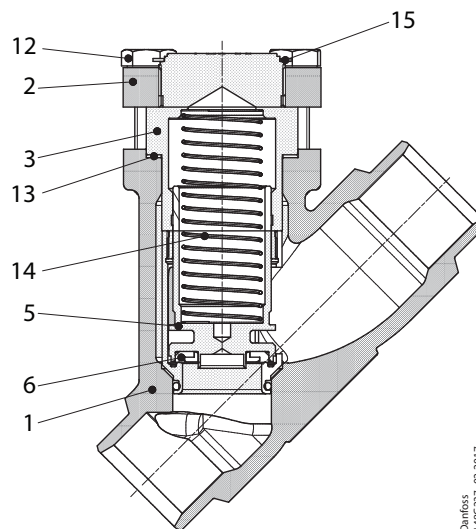

CHV-X 15 - 40

No.	Part	Material	DIN/EN	ISO	ASTM
1	Housing	Steel	P285QH EN10222-4		LF2A350
2	Bonnet, Flange	Steel	P275NL1 EN10028-3		
3	Bonnet, Insert	Steel			
4	Spindle	Stainless steel	X 10CrNiS18-9	Type 17, 17440	AISI 303, 683/13
5	Cone	Steel Teflon (PTFE)			
6	O-ring	Cloroprene (Neoprene)			
7	Spindle extension	Steel			
8	Packing gland O-rings	Steel Cloroprene (Neoprene)			
9	Packing washer	Aluminium			
10	Spring loaded seal	Teflon (PTFE)			
11	O-ring	Cloroprene (Neoprene)			
12	Bolts	Stainless steel	A2-70	A2-70	Type 308
13	Gasket	Fiber, non-asbestos			
14	Spring	Steel			
15	Identification ring	Stainless steel			
16	Seal cap gasket	Nylon			
17	Spindle seal cap	Aluminium			

Material specification

No.	Part	Material	DIN/EN	ISO	ASTM
1	Housing DN 50-65	Steel	P285 QH EN 10222-4		LF2A350
	Housing DN 80-125	Steel	G20Mn5 QT SEW 685		LCC, A352
2	Gasket	Fiber, Non-asbestos			
3	SCA-X: Valve bonnet CHV-X: End cover	Steel	P285 QH EN 10222-4		LF2A350
4	Bolts	Stainless steel	A2-70	A2-70	A-276
5	Tube	Steel			
6	Seat	Steel			
7	Valve plate	Steel			
8	Guide sleeve	Steel			
9	Spring ring	Steel			
10	Spring	Steel			
11	O-ring	Cloroprene (Neoprene)			
12	Teflon ring	Teflon (PTFE)			
13	Soft back seal	Teflon (PTFE)			
14	Spindle DN 50-65	Stainless steel	X8CrNiS18-9 17440	Type 17 R 683/13	AISI 303
	Spindle DN 80-125	Stainless steel	X5CrNi1810 17440	Type 11 683/13	AISI 304 A-276
15	Packing gland	Steel	9Mn28, 1651	Type 2, R 683/9	1213, SAE J403
16	Spindle seal cap and gasket	Aluminium			
17	Marking label	Stainless steel			
18	Eye bolt DIN 580	Steel			

Data sheet | Check & stop valve, type SCA-X - Check valve, type CHV-X

Connections

Size mm	Size in.	OD mm	T mm	OD in.	T in.			k_v Angleway m ³ /h	C_v Angleway USgal/min	K_v Straightway m ³ /h	C_v Straightway USgal/min
---------	----------	-------	------	--------	-------	--	--	--	--------------------------------	---	-----------------------------------

DIN

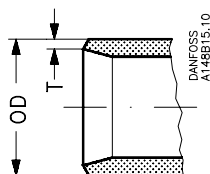

Butt-weld DIN (EN 10220)

15	½	21.3	2.3	0.839	0.091			8	9.3	4	4.6
20	¾	26.9	2.3	1.059	0.091			10	11.6	7	8.1
25	1	33.7	2.6	1.327	0.102			24	27.8	16	18.6
32	1¼	42.4	2.6	1.669	0.102			30	34.8	21	24.4
40	1½	48.3	2.6	1.902	0.102			30	34.8	21	24.4
50	2	60.3	2.9	2.37	0.11			45	53	28	34
65	2½	76.1	2.9	3.00	0.11			72	85	41	48
80	3	88.9	3.2	3.50	0.13			103	129	81	94
100	4	114.3	3.6	4.50	0.14			196	232	157	182
125	5	139.7	4.0	5.50	0.16			301	356	250	290

ANSI

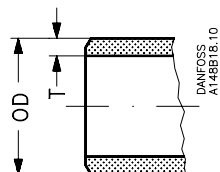

Butt-weld ANSI (B 36.10 Schedule 80)

15	½	21.3	3.7	0.839	0.146			8	9.3	4	4.6
20	¾	26.9	4.0	1.059	0.158			10	11.6	7	8.1
25	1	33.7	4.6	1.327	0.181			24	27.8	16	18.6
32	1¼	42.4	4.9	1.669	0.193			30	34.8	21	24.4
40	1½	48.3	5.1	1.902	0.201			30	34.8	21	24.4

Butt-weld ANSI (B 36.10 Schedule 40)

50	2	60.3	3.9	2.37	0.15			45	53	28	34
65	2½	73.0	5.2	2.87	0.20			72	85	41	48
80	3	88.9	5.5	3.50	0.22			103	129	81	94
100	4	114.3	6.0	4.50	0.24			196	232	157	182
125	5	141.3	6.6	5.56	0.26			301	356	250	290

GOST

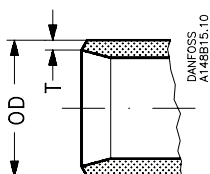

Butt-weld GOST (8734-75 and 8732-78)

15	½	18	2	0.709	0.079			8	9.3	4	4.6
20	¾	25	2.5	0.984	0.098			10	11.6	7	8.1
25	1	32	3	1.260	0.118			24	28.8	16	18.6
32	1¼	38	3	1.496	0.118			30	49.4	21	24.4
40	1½	45	3	1.772	0.118			30	52.4	21	24.4
50	2	57	3.5	2.244	0.138			45	53	28	34
65	2½	76.1	2.9	3	0.11			72	85	41	48
80	3	88.9	3.2	3.50	0.13			103	129	81	94
100	4	108	4	4.252	0.157			196	232	157	182
125	5	133	4	5.236	0.157			301	356	250	290

SOC

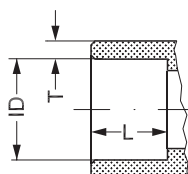

Size mm	Size in.	ID mm	T mm	ID in.	T in.	L mm	L in.				
---------	----------	-------	------	--------	-------	------	-------	--	--	--	--

Socket welding ANSI (B 16.11)

15	½	21.8	6	0.858	0.235	10	0.39				
20	¾	27.2	4.6	1.071	0.181	13	0.51				
25	1	33.9	7.2	1.335	0.284	13	0.51				
32	1¼	42.7	6.1	1.743	0.240	13	0.51				
40	1½	48.8	6.6	1.921	0.260	13	0.51				
50	2	61.2	6.2	2.41	0.24	16	0.63				

Dimensions and weights

SCA-X/CHV-X 15 - 40 (½- 1½ in.)

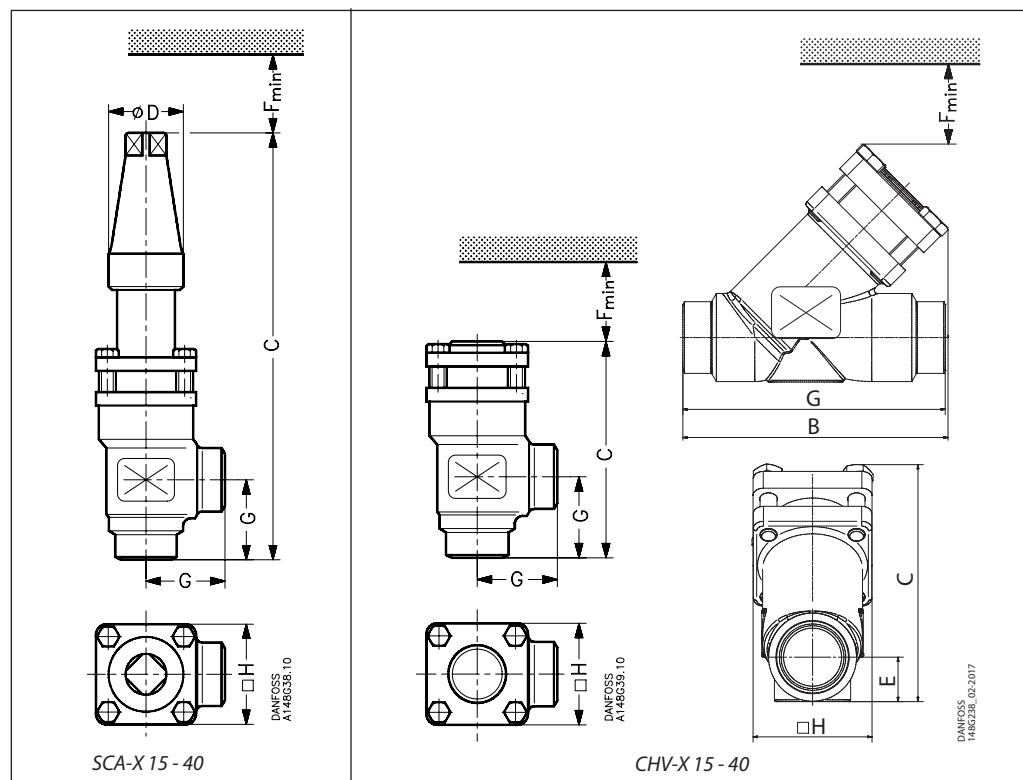

Valve size		C	G	ØD	F _{min}	□H	Weight
------------	--	---	---	----	------------------	----	--------

SCA-X 15 - 40

SCA-X 15 (½ in.)	mm in.	212 8.35	45 1.77	38 1.50	60 2.36	60 2.36	1.6 kg 3.53 lb
SCA-X 20 (¾ in.)	mm in.	212 8.35	45 1.77	38 1.50	60 2.36	60 2.36	1.6 kg 3.53 lb
SCA-X 25 (1 in.)	mm in.	295 11.61	55 2.17	50 1.97	85 3.35	70 2.76	3.2 kg 7.05 lb
SCA-X 32 (1¼ in.)	mm in.	295 11.61	55 2.17	50 1.97	85 3.35	70 2.76	3.2 kg 7.05 lb
SCA-X 40 (1½ in.)	mm in.	295 11.61	55 2.17	50 1.97	85 3.35	70 2.76	3.2 kg 7.05 lb

CHV-X 15 - 40 Angleway

CHV-X 15 (½ in.)	mm in.	103 4.06	45 1.77		60 2.36	60 2.36	1.2 kg 2.65 lb
CHV-X 20 (¾ in.)	mm in.	103 4.06	45 1.77		60 2.36	60 2.36	1.2 kg 2.65 lb
CHV-X 25 (1 in.)	mm in.	143 5.63	55 2.17		85 3.35	70 2.76	2.3 kg 5.07 lb
CHV-X 32 (1¼ in.)	mm in.	143 5.63	55 2.17		85 3.35	70 2.76	2.3 kg 5.07 lb
CHV-X 40 (1½ in.)	mm in.	143 5.63	55 2.17		85 3.35	70 2.76	2.3 kg 5.07 lb

Valve size		C	B	E	G	F _{min}	□H	Weight
------------	--	---	---	---	---	------------------	----	--------

CHV-X 15 - 40 Straightway

CHV-X 15 (½ in.)	mm in.	99 3.90	114 4.49	19 0.75	120 4.72	60 2.36	60 2.36	1.3kg 2.87lb
CHV-X 20 (¾ in.)	mm in.	99 3.90	114 4.49	19 0.75	120 4.72	60 2.36	60 2.36	1.3kg 2.87lb
CHV-X 25 (1 in.)	mm in.	141 5.55	157 6.18	26 1.02	155 6.10	85 3.35	70 2.76	2.6kg 5.73lb
CHV-X 32 (1¼ in.)	mm in.	141 5.55	157 6.18	26 1.02	155 6.10	85 3.35	70 2.76	2.6kg 5.73lb
CHV-X 40 (1½ in.)	mm in.	141 5.55	157 6.18	26 1.02	155 6.10	85 3.35	70 2.76	2.6kg 5.73lb

CHV-X 32-40 Straightway, Socket weld

CHV-X 32-40 (1¼ - 1½ in.)	mm in.	132 5.20	156 6.14	26 1.02	155 6.10	85 3.35	70 2.76	2.8kg 6.11lb
---------------------------	-----------	-------------	-------------	------------	-------------	------------	------------	-----------------

Specified weights are approximate values only.

Dimensions and weights

SCA-X/CHV-X 50 - 65 (2 - 2½ in.)

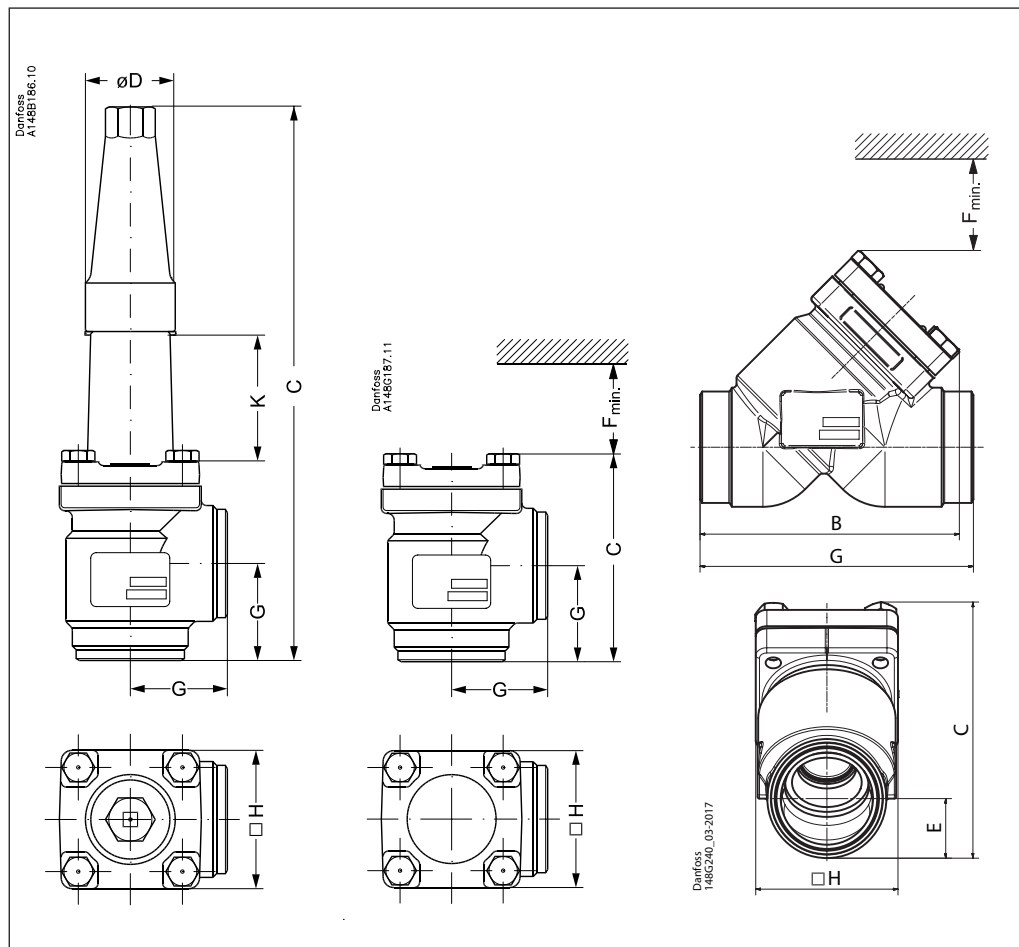

Valve size	K	C	G	ØD	□H	Weight
------------	---	---	---	----	----	--------

SCA-X

SCA-X 50	mm	70	315	60	50	77	3.8 kg
SCA-X (2)	in.	2.76	12.40	2.36	1.97	3.03	8.40 lb
SCA-X 65	mm	70	335	70	50	90	5.5 kg
SCA-X (2½)	in.	2.76	13.19	2.76	1.97	3.54	12.16 lb

Valve size	C	G	F _{min.}	□H	Weight
------------	---	---	-------------------	----	--------

CHV-X Angleway

CHV-X 50	mm	132	60	92	77	3.2 kg
CHV-X (2)	in.	5.20	2.36	3.62	3.03	7.10 lb
CHV-X 65	mm	152	70	107	90	4.5 kg
CHV-X (2½)	in.	5.98	2.76	4.21	3.54	9.95 lb

Valve size	C	B	E	G	F _{min.}	□H	Weight
------------	---	---	---	---	-------------------	----	--------

CHV-X Straightway

CHV-X 50	mm	139	140	32	148	92	77	3 kg
CHV-X (2)	in.	5.47	5.51	1.26	5.83	3.62	3.03	6.72 lb
CHV-X 65	mm	163	164	40	176	107	90	4.3 kg
CHV-X (2½)	in.	6.4	6.4	1.6	6.9	4.21	3.54	9.44 lb

CHV-X Straightway, Socket weld

CHV-X 50	mm	142	147	37	162	92	77	3.8 kg
CHV-X (2)	in.	5.59	5.79	1.46	6.38	3.62	3.03	8.33 lb

Specified weights are approximate values only.

Dimensions and weights

SCA-X/CHV-X 80 - 125 (3 - 5 in.)

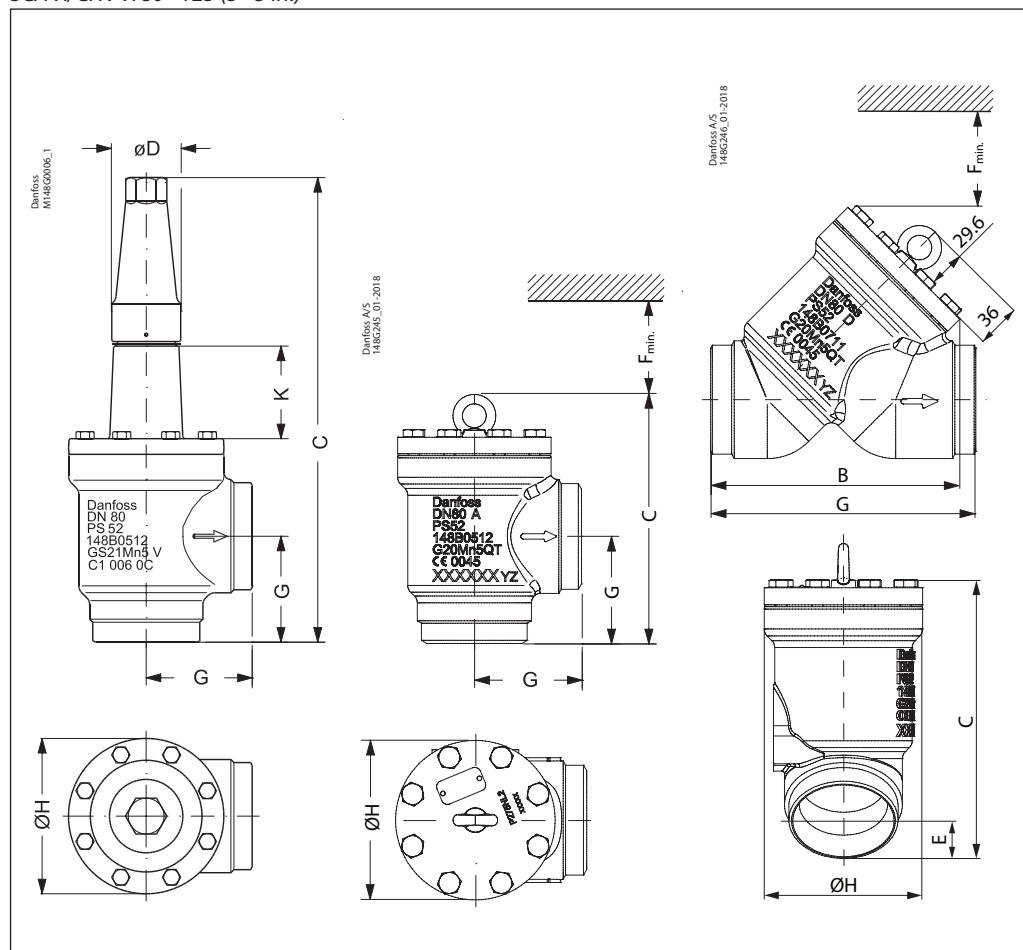

Valve size	K	C	G	ØD	ØH	Weight
------------	---	---	---	----	----	--------

SCA-X

SCA-X 80	mm	76	388	90	58	129	9.7 kg
SCA-X (3)	in.	3.00	15.28	3.54	2.28	5.08	21.4 lb
SCA-X 100	mm	90	437	106	58	156	15.3 kg
SCA-X (4)	in.	3.54	17.20	4.17	2.28	6.14	33.7 lb
SCA-X 125	mm	90	533	128	74	193	28.1 kg
SCA-X (5)	in.	3.54	20.98	5.04	2.91	7.60	61.9 lb

Valve size	C	G	F _{min.}	ØH	Weight
------------	---	---	-------------------	----	--------

CHV-X Angleway

CHV-X 80	mm	218.6	90	103.4	129	8.7 kg
CHV-X (3)	in.	8.61	3.54	4.07	5.08	19.23 lb
CHV-X 100	mm	252.6	106	133.4	156	14.3 kg
CHV-X (4)	in.	9.94	4.17	5.25	6.14	31.60 lb
CHV-X 125	mm	297.6	128	160.4	193	25.6 kg
CHV-X (5)	in.	11.72	5.04	6.31	7.60	56.58 lb

Valve size	C	B	E	G	F _{min.}	ØH	Weight
------------	---	---	---	---	-------------------	----	--------

CHV-X Straightway

CHV-X 80	mm	206	204	48	216	133	129	9.3 kg
CHV-X (3)	in.	8.11	8.03	1.89	8.50	5.24	5.08	20.4 lb
CHV-X 100	mm	256	248	62	264	163	156	14.6 kg
CHV-X (4)	in.	10.08	9.76	2.44	10.39	6.43	6.14	32.29 lb
CHV-X 125	mm	314	302	74	322	190	193	32.5 kg
CHV-X (5)	in.	12.36	11.89	2.91	12.68	7.48	7.60	71.65 lb

Specified weights are approximate values only.

Ordering complete valves

How to order

The table below is used to identify the valve required.

For further information please contact your local Danfoss Sales Company.

Please note that the type codes only serve to identify the valves, some of which may not form part of the standard product range.

Valve type	SCA-X CHV-X	Check & stop valve Check Valve				
(valve size measured on the connection diameter)	15 20 25 32 40 50 65 80 100 125	DN 15 DN 20 DN 25 DN 32 DN 40 DN 50 DN 65 DN 80 DN 100 DN 125	A x x x x x x x x x x	D x x x x x x x x x x	G x x x x x x x x x x	SOC x x x x x x x x x x
Connections	A D G SOC	Welding branches: ANSI B 31.5 schedule 80 DN 15 - 40 (½ - 1½ in.) Welding branches: ANSI B 31.5 schedule 40 DN 50 - 125 (2 - 5 in.) Welding branches: EN 10220 Butt-weld connection: GOST (8734-75 and 8732-78) Socket weld: ANSI B 16.11				
Valve housing	ANG STR	Angle flow Straight flow				

Important!

Where products need to be certified according to specific certification societies the relevant information should be included at the time of order.

Angleway

SCA-X Butt-weld DIN (EN 10220)

Size		Type	Code No.
mm	in.		
15	½	SCA-X 15 D ANG	148B5208
20	¾	SCA-X 20 D ANG	148B5308
25	1	SCA-X 25 D ANG	148B5408
32	1¼	SCA-X 32 D ANG	148B5508
40	1½	SCA-X 40 D ANG	148B5608
50	2	SCA-X 50 D ANG	148B5702
65	2½	SCA-X 65 D ANG	148B5803
80	3	SCA-X 80 D ANG	148B5902
100	4	SCA-X 100 D ANG	148B6002
125	5	SCA-X 125 D ANG	148B6102

Angleway

CHV-X Butt-weld DIN (EN 10220)

Size		Type	Code No.
mm	in.		
15	½	CHV-X 15 D ANG	148B5236
20	¾	CHV-X 20 D ANG	148B5336
25	1	CHV-X 25 D ANG	148B5436
32	1¼	CHV-X 32 D ANG	148B5536
40	1½	CHV-X 40 D ANG	148B5636
50	2	CHV-X 50 D ANG	148B5736
65	2½	CHV-X 65 D ANG	148B5838
80	3	CHV-X 80 D ANG	148B5936
100	4	CHV-X 100 D ANG	148B6036
125	5	CHV-X 125 D ANG	148B6136

SCA-X Butt-weld ANSI (B 36.10 Schedule 80)

Size		Type	Code No.
mm	in.		
15	½	SCA-X 15 A ANG	148B5209
20	¾	SCA-X 20 A ANG	148B5309
25	1	SCA-X 25 A ANG	148B5409
32	1¼	SCA-X 32 A ANG	148B5509
40	1½	SCA-X 40 A ANG	148B5609

CHV-X Butt-weld ANSI (B 36.10 Schedule 80)

Size		Type	Code No.
mm	in.		
15	½	CHV-X 15 A ANG	148B5237
20	¾	CHV-X 20 A ANG	148B5337
25	1	CHV-X 25 A ANG	148B5437
32	1¼	CHV-X 32 A ANG	148B5537
40	1½	CHV-X 40 A ANG	148B5637

SCA-X Butt-weld ANSI (B 36.10 Schedule 40)

Size		Type	Code No.
mm	in.		
50	2	SCA-X 50 A ANG	148B5703
65	2½	SCA-X 65 A ANG	148B5802
80	3	SCA-X 80 A ANG	148B5903
100	4	SCA-X 100 A ANG	148B6004
125	5	SCA-X 125 A ANG	148B6103

CHV-X Butt-weld ANSI (B 36.10 Schedule 40)

Size		Type	Code No.
mm	in.		
50	2	CHV-X 50 A ANG	148B5737
65	2½	CHV-X 65 A ANG	148B5837
80	3	CHV-X 80 A ANG	148B5937
100	4	CHV-X 100 A ANG	148B6037
125	5	CHV-X 125 A ANG	148B6137

SCA-X Socket welding ANSI (B 16.11)

Size		Type	Code No.
mm	in.		
50	2	SCA-X 50 SOC ANG	148B5704

CHV-X Socket welding ANSI (B 16.11)

Size		Type	Code No.
mm	in.		
32	1¼	CHV 32 SOC ANG	148B5539
50	2	CHV 50 SOC ANG	148B5740

ANG = Angleway

Ordering complete valves
(continued)

Straightway

CHV-X Butt-weld DIN (EN 10220)

Size		Type	Code No.
mm	in.		
15	½	CHV-X 15 D STR	148B6581
20	¾	CHV-X 20 D STR	148B6583
25	1	CHV-X 25 D STR	148B6585
32	1¼	CHV-X 32 D STR	148B6587
40	1½	CHV-X 40 D STR	148B6589
50	2	CHV-X 50 D STR	148B6591
65	2½	CHV-X 65 D STR	148B6593
80	3	CHV-X 80 D STR	148B6595
100	4	CHV-X 100 D STR	148B6597
125	5	CHV-X 125 D STR	148B6599

CHV-X Butt-weld ANSI (B 36.10 Schedule 80)

Size		Type	Code No.
mm	in.		
15	½	CHV-X 15 A STR	148B6582
20	¾	CHV-X 20 A STR	148B6584
25	1	CHV-X 25 A STR	148B6586
32	1¼	CHV-X 32 A STR	148B6588
40	1½	CHV-X 40 A STR	148B6590

CHV-X Butt-weld ANSI (B 36.10 Schedule 40)

Size		Type	Code No.
mm	in.		
50	2	CHV-X 50 A STR	148B6592
65	2½	CHV-X 65 A STR	148B6594
80	3	CHV-X 80 A STR	148B6596
100	4	CHV-X 100 A STR	148B6598
125	5	CHV-X 125 A STR	148B6600

CHV-X Socket welding ANSI (B 16.11)

Size		Type	Code No.
mm	in.		
15	½	CHV-X 15 SOC STR	148B6601
20	¾	CHV-X 20 SOC STR	148B6602
25	1	CHV-X 25 SOC STR	148B6603
32	1¼	CHV-X 32 SOC STR	148B6604
40	1½	CHV-X 40 SOC STR	148B6605
50	2	CHV-X 50 SOC STR	148B6606

STR = Straightway

Ordering SCA-X from the parts programme

Example
(select from
table 1 and 2)

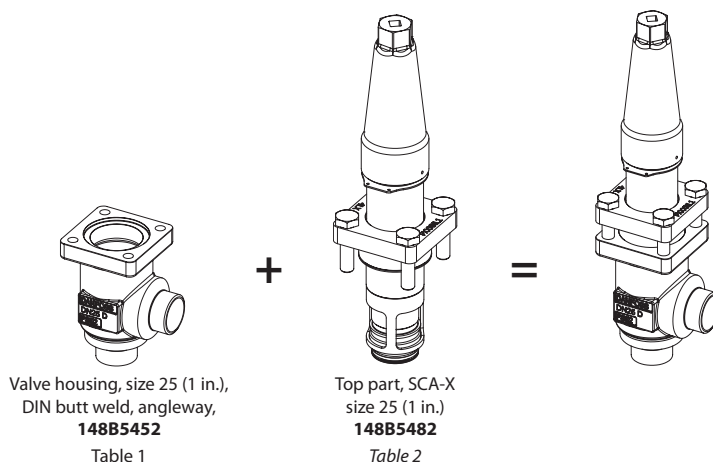
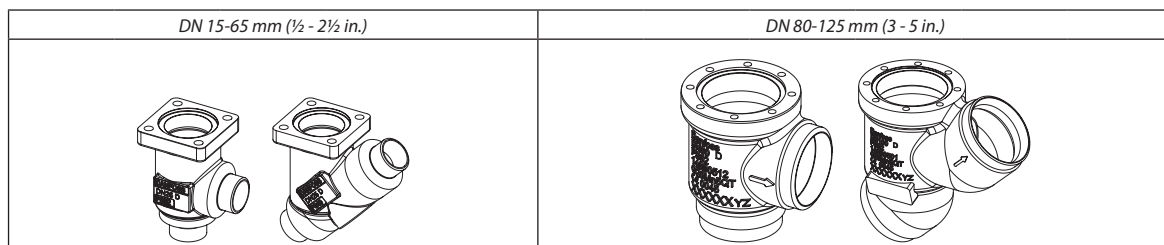
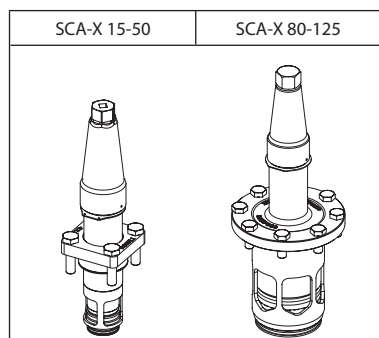

Table 1
SVL valve housings
w/different
connections



Sizes [DN]		Valve Housing SVL										
		DIN-Butt weld		ANSI-Butt weld		GOST-Butt-weld		SOC		FPT		T
mm	in.	ANG	STR	ANG	STR	ANG	STR	ANG	STR	ANG	STR	ANG
15	1/2	148B5252	148B5253	148B5254	148B5255	148B5391	148B5392	148B5256	148B5257	148B5258	148B5259	
20	3/4	148B5352	148B5353	148B5354	148B5355	148B5393	148B5394	148B5356	148B5357	148B5358	148B5359	
25	1	148B5452	148B5453	148B5454	148B5455	148B5498	148B5499	148B5456	148B5457	148B5458	148B5459	
32	1 1/4	148B5576	148B5577	148B5578	148B5579	148B5593	148B5594	148B5580	148B5581	148B5582	148B5583	
40	1 1/2	148B5652	148B5653	148B5654	148B5655	148B5681	148B5682	148B5656	148B5657			
50	2	148B5741	148B5742	148B5743	148B5744	148B5759	148B5760	148B5745	148B5746			
65	2 1/2	148B5816	148B5817	148B5818	148B5819	148B5816	148B5817					
80	3	148B5912	148B5913	148B5914	148B5915	148B5912	148B5913					
100	4	148B6014	148B6015	148B6016	148B6017	148B6033	148B6034					
125	5	148B6112	148B6113	148B6114	148B6115	148B6133	148B6134					

Table 2
SCA-X complete top part
including gaskets and
bolts



Sizes [DN]		Complete top part
mm	in.	SCA-X
15	1/2	148B5282
20	3/4	
25	1	
32	1 1/4	148B5482
40	1 1/2	
50	2	148B5735
65	2 1/2	148B5825
80	3	148B5918
100	4	148B6019
125	5	148B6118

Replacement kit (O-ring replacement) for R717 Ammonia Heat Pump* and Propylene applications (including ID tag)

Size (DN)		O-ring kit for	
mm	in.	R717 Heat pump	R1270 Propylene
15	1/2	148B6070	148B6077
20	3/4		
25	1	148B6071	148B6078
32	1 1/4		
40	1 1/2		
50	2	148B6072	148B6079
65	2 1/2	148B6073	148B6080
80	3	148B6074	148B6081
100	4	148B6075	148B6082
125	5	148B6076	148B6083

* Replacement kits for R717 Ammonia Heat Pump is applicable for continuous operating temperature between +100°C to 150°C (212°F to 302°F)

Ordering CHV-X from the parts programme

Example
(select from
table 1 and 2)

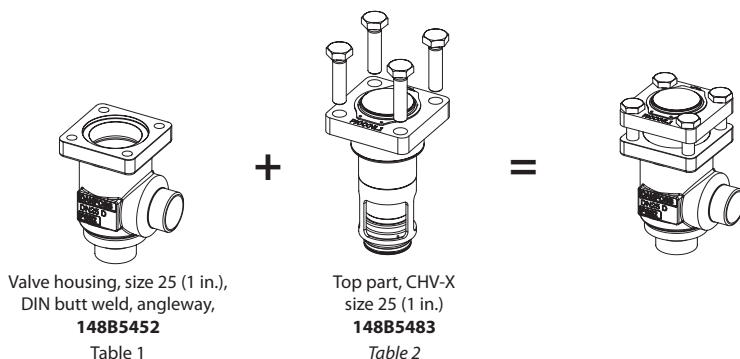

Table 1
SVL valve housings
w/different
connections

Sizes [DN]		DN 15-65 mm (½ - 2½ in.)						DN 80-125 mm (3 - 5 in.)					
		DIN-Butt weld		ANSI-Butt weld		GOST-Butt-weld		SOC		FPT		T	
mm	in.	ANG	STR	ANG	STR	ANG	STR	ANG	STR	ANG	STR	ANG	
15	½	148B5252	148B5253	148B5254	148B5255	148B5391	148B5392	148B5256	148B5257	148B5258	148B5259		
20	¾	148B5352	148B5353	148B5354	148B5355	148B5393	148B5394	148B5356	148B5357	148B5358	148B5359		
25	1	148B5452	148B5453	148B5454	148B5455	148B5498	148B5499	148B5456	148B5457	148B5458	148B5459		
32	1¼	148B5576	148B5577	148B5578	148B5579	148B5593	148B5594	148B5580	148B5581	148B5582	148B5583		
40	1½	148B5652	148B5653	148B5654	148B5655	148B5681	148B5682	148B5656	148B5657				
50	2	148B5741	148B5742	148B5743	148B5744	148B5759	148B5760	148B5745	148B5746				
65	2½	148B5816	148B5817	148B5818	148B5819	148B5816	148B5817						
80	3	148B5912	148B5913	148B5914	148B5915	148B5912	148B5913						
100	4	148B6014	148B6015	148B6016	148B6017	148B6033	148B6034						
125	5	148B6112	148B6113	148B6114	148B6115	148B6133	148B6134						

Table 2
CHV-X complete top part
including gaskets and
bolts

Sizes [DN]		CHV-X 15-50	CHV-X 80-125
mm	in.	Complete top part CHV-X	
15	½	148B5283	
20	¾	148B5283	
25	1	148B5483	
32	1¼	148B5483	
40	1½	148B5483	
50	2	148B5747	
65	2½	148B5827	
80	3	148B5919	
100	4	148B6022	
125	5	148B6119	

Replacement kit (O-ring replacement) for R717 Ammonia Heat Pump* and Propylene applications (including ID tag)

Size (DN)		O-ring kit for	
mm	in.	R717 Heat pump	R1270 Propylene
15	½	148B6070	148B6077
20	¾		
25	1	148B6071	148B6078
32	1¼		
40	1½	148B6072	148B6079
50	2		
65	2½	148B6073	148B6080
80	3	148B6074	148B6081
100	4	148B6075	148B6082
125	5	148B6076	148B6083

* Replacement kits for R717 Ammonia Heat Pump is applicable for continuous operating temperature between +100°C to 150°C (212°F to 302°F)

ENGINEERING
TOMORROW

