



**TOWNLEY SLURRY HANDLING VALVES**  
Knife Gate and Butterfly Valve Solutions

**TOWNLEY**

Engineering & Manufacturing Co., Inc.





## Townley Slurry Handling Valves

Townley has created a unique line of slurry valves specifically designed to provide excellent reliable service in severe applications found in matrix, in-plant beneficiation and tailings for mining, as well as, limestone slurry, bottom ash-handling and water isolation in coal fired power plants.

A large inventory of these quality valves are on hand and ready for immediate service.







## Series 80-TP Towniprene<sup>®</sup> Lined Knife Gate Valves

The 80-TP is the work horse of the industry, with many applications in fine feed where positive closure is required, such as limestone Cyclone feed & FGD service in Coal Fired Power Plants and mineral & metal mining control of fine feed in flotation cyclones and tailings. Resistant to mild reagents and acids, this 80-TP is a very versatile addition to your process.

Townley's proprietary Towniprene<sup>®</sup> urethane is bonded into the cavity of a heavy-duty cast ductile iron body and into the packing cavity, creating an excellent seal arrangement when coupled with the Teflon lubricated adjustable packing. Formed with precise molds that create the flush resilient blade seat, with lateral sealing which extends onto the mounting flange surfaces assuring a positive compression face to face seal to pipe flanges. The 316L blade is machined with an edge radius and NEDOX lubricating treatment. This treatment ensures optimum blade movement and keeps the blade clean, preventing wear problems caused from material build-up.

With a max operating pressure of 150 PSI and 165° F service conditions, the 80-TP will provide excellent service 24/7. Featuring a self-cleaning seat apex to clear debris, the valve will seal positively.

This bi-directional knife gate valve features Teflon lubricated adjustable packing and is available in standard sizes from 2" to 30" I.D. for quick delivery with larger sizes and pressures available upon request.

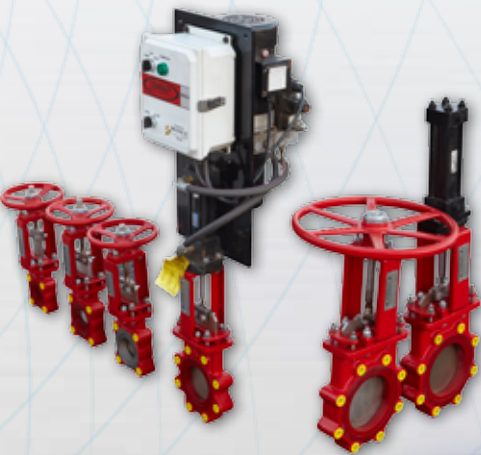

**TOWNLEY**

Engineering & Manufacturing Co., Inc.



## Series 80-TP/XL Knife Gate Valves

The 80-TP/XL is the newest valve in our inventory, created as a bolt-in replacement for the wide bodied bottom purge style slurry valves. With many applications in fine feed where positive closure is required, such as limestone cyclone feed & FGD service in coal fired power plants and mineral & metal mining control of fine feed in cyclones, flotation and tailings. This valve is very resistant to mild reagents and acids, this 80-TP/XL is a very versatile addition to your process.

Townley's proprietary Towniprene® urethane is bonded into the cavity of a heavy-duty cast ductile iron body. Formed with precise molds that create the flush resilient blade seat, lateral sealing which extends onto the mounting flange surfaces assuring a positive face to face compression seal to pipe flanges. The 316L blade is machined with an edge radius and NEDOX lubricating treatment to ensure optimum blade movement.

With a max operating pressure of 150 PSI and 165° F service conditions, the 80-TP/XL will provide excellent service 24/7. Featuring a self-cleaning seal apex to clear debris, the valve will seat positively.

As with the updated versions of the 80-TP and 80-BA series valves, this wide body knife gate valve has the extended molded Towniprene® into the packing cavity, creating an excellent seal arrangement when coupled with the Teflon lubricated adjustable packing and is available in standard sizes from 3" to 12" I.D. for quick delivery. 14" - 24" available soon.

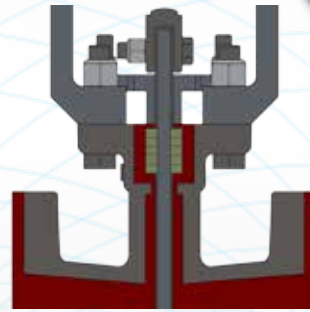

## Series 80-BA Severe Duty Knife Gate Valves

The 80-BA/SD is a heavy duty knife gate valve for solids handling, with many applications in coarse feed where positive closure is required with maximum resistance to impact abrasion such as found in Bottom Ash discharge service in Coal Fired Power Plants and face of the mine, mill regrind and coarse tailing circuits in mineral & metal mining. Resistant to mild reagents and acids, this 80-BA/SD is a very versatile addition to your process.

Townley's proprietary Towniprene® urethane is bonded into the cavity of a heavy-duty cast ductile iron body and into the packing cavity, creating an excellent seal arrangement when coupled with the Teflon lubricated adjustable packing. Formed with precise molds that create the resilient blade seat and lateral sealing. The 316L blade is machined with an edge radius and NEDOX lubricating treatment. This treatment ensures optimum blade movement and keeps the blade clean, preventing wear problems caused from material build-up.

With a max operating pressure of 150 PSI and 165°F service conditions, the 80-BA/SD will provide excellent utility 24/7. Featuring duplicate face to face white-iron bonded and sealed inserts, the bulk of coarse feed impact is absorbed here in the main feed stream while protecting the Towniprene® seat and seal to ensure positive closure.

This bi-directional knife gate valve features Teflon lubricated adjustable packing and is available in standard sizes from 3" to 24" I.D. for quick delivery with larger sizes and pressures available upon request.



**TOWNLEY**

Engineering & Manufacturing Co., Inc.



## Series 150 Knife Gate Valves

The Series 150 fabricated bi-directional valves were created in response to customer's need of a robust valve for coarse solids and tailings service in mining. These valves have found use in abrasive bottom ash discharge circuits in coal fired power plants.

The CAD/CAM designed and CNC plasma-cut components are robot welded and pressure tested to ensure long reliable life in the field. The cast stainless steel double taper blade ensures positive open and close every cycle.

The tapered blade mates to a matching Towniprene® urethane seat, that has been chemically bonded to the metal body and incorporates opposing high-chrome cast inserts to absorb the constant coarse feed 24/7 with operating temperatures at 165° F or lower.

Available from 4" to 36" full port ID, the wide-bodied flanges come standard with 150 flange drilling or can be drilled to match your piping arrangement.

The bonneted design feature and the packing seal around the shaft ensures a reliable non-leaking environment.

This valve can be factory rebuilt providing a 100% new valve at a fraction of the original costs.

With a variety of actuation options and lock-outs, you will have years of excellent service.

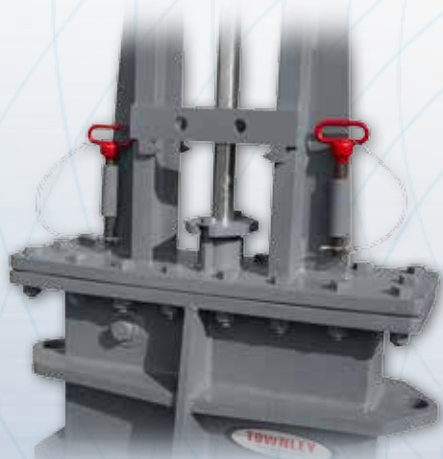

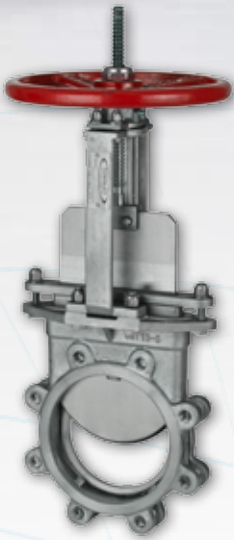

## Series 80-SS Knife Gate Valves

The Series 80-SS style valve was created to provide a unique valve for service where chemicals and higher temperatures are expected.

Featuring a cast 304 or 316 stainless body, gate, packing gland, seat, yoke, stem and bolting, you can be assured of corrosion resistant duty.

This particular valve is directional, with a precision machined metal to metal seat and positive seal where high temperature or chemically active media will be present, damaging elastomer seats or seals.

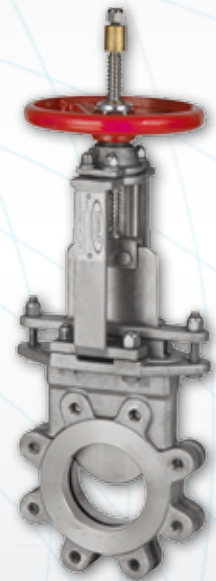

## Series 80-SSRS Knife Gate Valves

The Series 80-SSRS style bi-directional valve was created to provide a unique valve for service where chemicals and higher temperatures are expected.

Featuring a cast 316 stainless body, gate, packing gland, seat, 304 yoke, stem and bolting, you can be assured of corrosion resistant duty.

This valve has a precision machined metal blade and a standard replaceable BUNA-N with optional rubber seat available that snaps into a cast "T" slot and provides a bubble-tight positive seal.

Available in 2" to 24" true ID with a working pressure of 150 PSI, this valve works well in when moderate high temperature and chemically active media will be present.

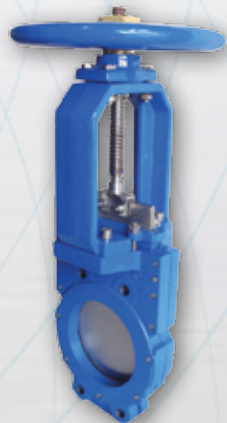

## Series 80-DI Knife Gate Valves

The Series 80-DI is a very utilitarian valve for general service like water, pulp, solids, powders, when economy is important.

Available from 3" to 14" true ID port, a two piece cast ductile iron body, a stainless steel blade and a bubble tight field-replaceable natural rubber seat, you can expect a good service life in a variety of applications.

**TOWNLEY**

Engineering & Manufacturing Co., Inc.



## Series 120 Butterfly Valves

Designed for handling high volume solution flow, this Townley bi-directional valve is an excellent choice for throttling, diversion or isolation service for water or fine slurry found in: Water circulation control, Brackish, salt or fresh water, Power plant cooling water isolation

### FEATURES:

- Internal diameters from 18" to 96"
- A robust fabricated steel body gusseted and drilled to your specifications.
- Bonded-in durable integral cast Towniprene® urethane seat and full-face flange gaskets
- Solid through-disk shaft with upper & lower bronze bushings and bronze thrust bearings
- Fabricated convex shaped resilient neoprene lined-disk pinned to shaft with Towniprene® caps to seal and prevent galvanic corrosion
- Interference fit of softer neoprene disk to Towniprene® Seat, which ensures positive sealing when closed
- No exposed metal in process flow
- Pressure and torque tested to your specifications prior to shipping
- Wide variety of actuator options

**Towniprene® 85 durometer**

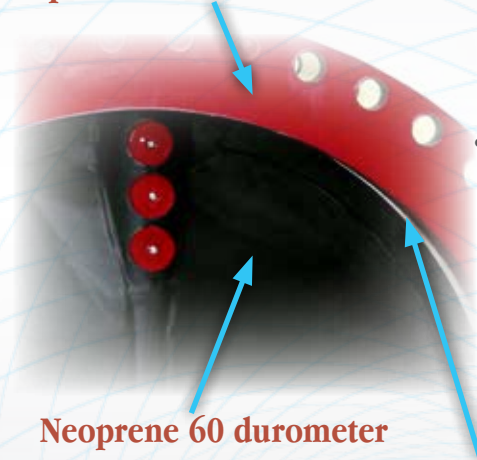

**Neoprene 60 durometer**

**Interference fit**

### BENEFITS:

- Durable design
- Improved flow coefficient
- Mollusk resistant elastomers
- Positive seal
- Bi-directional
- Quick turn around
- Excellent value
- One piece shaft



Disclaimer: The information presented herein is a general guide to our products.

We make no warranties, expressed or implied, with respect to the accuracy or usefulness of the information contained. Townley reserves the right to change technical specifications from time to time without notice.

Use of any and all information in this document is at the sole discretion of the user.





## Butterfly Valves Remanufacture

We can rebuild your existing worn valve to “like-new” condition with a **NEW Valve Warranty** for a variety of OEM styles including Keystone, Media, DeZurik, Henry Pratt, Mosser, BIF, Rodney Hunt and Allis Chalmers.

We incinerate the existing elastomer, machine & repair the metal body if required, replace all bushings and seals, build a new style disk then follow all the steps as noted for a new valve.

- Rebuilt from your worn valve
- Typically existing actuators can be reused
- Enhancements to Core
- One Piece Shaft
- Positive Seal
- Tapered Pins
- Towniprene® Caps
- Convex Disk

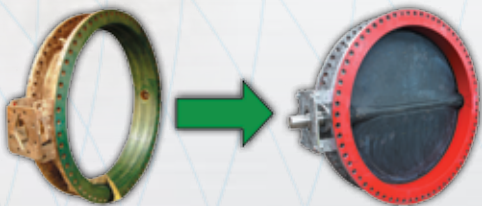

**TOWNLEY**

Engineering & Manufacturing Co., Inc.



## Butterfly Valves Series TM3 & TM4

- Cost-effective ductile iron body
- Available with optional lock out feature
- New generation, cartridge-style, metal reinforced EPDM rubber seat will not blow or roll out due to high pressure or velocity
- Precision machined disc is available in either cast 316 stainless steel or ductile iron/nickel plated
  - Shaft is 410 stainless steel
  - PTFE bushings provide consistently smooth operations
- Available in wafer style (TM3) or lug style (TM4) to suit your operating needs
- A variety of operator configurations are also available, including: Spring lever with notch plate, manual gear with hand-wheel, pneumatic rack & pinion, electric, or hydraulic
  - 12" Lock Out Feature on the lever

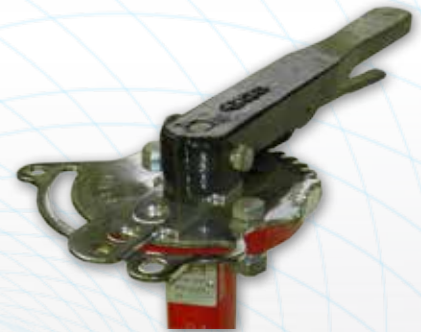

## Townley Pinch Valves for Slurry Modulation

Townley's **Pinch Valves** will operate with occasional actuation or with constant automatic modulation driven by flow control circuits. Designed with unique self-centering, double action pinch bars that compress the tube equally from both sides, you will experience uniform wear from both sides. Additionally, you may extend the life somewhat by rotating the hose and changing the pinch point by 90°.





## Actuators & Accessories

Townley provides manual or powered actuation, positioners, limit switches, lock-outs and remote control operations and many more accessories for all of our valves or our valve bodies to match the customer's existing set-up.

### Application, operation and physical considerations

Important when selecting actuation and controls

Safety – Lock-outs and cages

Media flow and frequency - Open/shut or modulation

Media conditions – materials of construction, operating pressures

Flow control – Position alerts, limit switches, feedback loop

Space / orientation – Vertical space available, piping arrangement

Service feed – Reliable air, hydraulic or electric plant service, remote self-contained options

Inventory requirements – Ship from stock, local inventory

### Manual Actuation

Hand wheel Actuation for knife gate valves

Lever Actuation for butterfly valves

Gear actuation for knife gate valves and butterfly valves

### Powered Actuation

Compressed air, Hydraulic or Electric-driven mechanical Actuation for knife gate valves and butterfly valves

### Powered with Manual Override

For critical applications with potential service loss

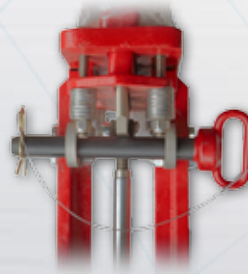
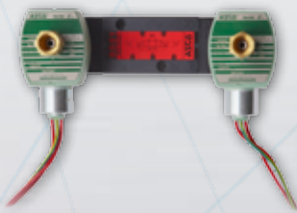

**TOWNLEY**

Engineering & Manufacturing Co., Inc.

Proud Member



*But now, O Lord, You are our Father; We are the clay, and You our potter;  
And all we are the work of Your hand. - Proverbs 16:3*



**TOWNLEY**

**Engineering & Manufacturing Co., Inc.**

Mail: P.O. Box 221 • Candler, FL 32111 • 10551 SE 110th St. Rd.

Phone: (800)342-9920 • Fax: (352) 687-1862

[www.townley.net](http://www.townley.net)

Made in the USA

