

Natural Gas Technologies

Solutions for the Natural Gas Industry





TARTARINI™ **FISHER™**

Natural gas pressure regulating and metering stations. Pressure regulators, slam-shut valves, relief valves and accessories. Remote control equipment. Engineering, adaptation of existing installations to meet current standard requirements. Theoretical and practical training.

Table of Contents

 Pilot-Operated Pressure Reducing Regulators	Page
FL Series	6
FL-BP Series	7
FL-FR Series (French Market Only)	8
Cronos Series	9
Cronos-FR Series (French Market Only)	10
EZH and EZHSO Series	11
Type 971	12
EZR Series	13
Accessories for Pilot-Operated Pressure Reducing Regulators	
PS and RE Series - Regulator Pilots	14
PRX Series - Regulator Pilots	15
Standard Pilot Systems - Regulator Pilots	16
V/31-2 - Booster Valve	17
Type RPE - Electric Pilot Heater	18
Types SR, SRS, SRII, SRSII, and STP - Silencers	19
 Pneumatic-Loaded Pressure Reducing Regulators	
Type RP/10	20
Type RLC/20	21
 Spring-Loaded Pressure Reducing Regulators	
MF and MN Series	22
A/100 Series	23
A/140 Series	24
B/240 Series	25
RP Series	26
Type CSB400	27
Type CSB600 / CSB700	28
Type CS800	29
R Series	30
Type R/25	31
Type B NV	32

Table of Contents

Slam-Shut Valves

Page

BM5 Series	33
BM6X Series	34
Type OSE	35
Type VS100	36

Relief Valves

VS-FL and VS-FL-FR Series (French Market Only)	37
V Series	38

Valves, Heat Exchangers, Filters

VFA Series - Butterfly Valves	39
CNF, CN, CF and SV Series - Tube Bundle Heat Exchangers	40
FA, FAG and FG Series - Filters	41
Types BLE and BLX - Throttle Valve	42

Odorizing Systems

OL Series - Absorption Odorizing System	43
Type Dosaodor-D - Odorant Injection System	44
Type Dosaodor DO200 - Odorant Injection System	45

Smart Grid Management & Integrated Solutions

Skids, Stations & Odoration	46
Type RAF - NG PRMS Station Controller	47
V/31-2-E Series - Switch for Flow Partition System	48

Services

After Sales and Training	49
Original Eco-Sustainable Spare Parts	50

Introduction

The FL Series regulators are accurate pilot-operated, pressure balanced, soft seated regulators designed for high-pressure transmission/city gate, large capacity distribution systems, and power plant feeds.

The FL Series provides smooth and quiet operation, tight shutoff, and long life.

The FL Series is in conformity with the Pressure Equipment Directive PED 2014/68/UE and is classified under Category IV.

Available Configurations

Type FL:

High Pressure Regulator or Monitor

Type MFL:

High Pressure Regulator + Monitor

Type BFL:

High Pressure Regulator + Shutoff

All FL type regulators are available with or without:

Type SR / SRII: Silencer

Type SRS / SRSII: Silencer with widened outlet flange

A widened outlet version without built-in silencer is also available.

Body Sizes

FL Series:

DN 25, 40, 50, 65, 80, 100, 150*, 200*, and 250*
(NPS 1, 1-1/2, 2, 2-1/2, 3, 4, 6*, 8*, and 10*)

FL Series with Type SRS / SRSII Silencer or Widened Outlet:

DN 25 x 100, 40 x 150, 50 x 150, 65 x 200, 80 x 250, 100 x 250, 150 x 300*, 200 x 400* and 250 x 500*
(NPS 1 x 4, 1-1/2 x 6, 2 x 6, 2-1/2 x 8, 3 x 10, 4 x 10, 6 x 12*, 8 x 16* and 10 x 20*)

* These sizes are not available in MFL and BFL configurations.

End Connection Styles

CL300, and CL600

Inlet Pressure Ranges

Allowable Pressure: Up to 100 bar

Inlet Pressure Range: 1 to 100 bar

Outlet Pressure Range

0.5 to 80 bar

Minimum Operating Differential Pressure

0.5 bar

Accuracy Class

Up to ±1%

Lock-Up Pressure Class

Up to +5%

Class of Lock-Up Pressure Zone

Up to 5%

Built-In Shutoff Valve

Independent Pneumatic Control

Manual Reset

Accuracy Group: Up to ±1%

Response Time: ≤1 s

Temperature Capabilities

Standard Version:

Working: -10° to 60 °C

Low Temperature Version:

Working: -20° to 60 °C

Approximate Weights (Including Pilot)

31 to 1190 kg

Features

- No Atmospheric Bleed
- Quiet Operation
- Control Accuracy
- Versatility
- Easy In-Line Maintenance
- Tight Shutoff
- High Capacity
- In-Service Travel Indicator

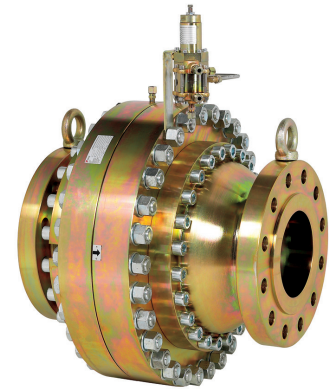

TYPE FL

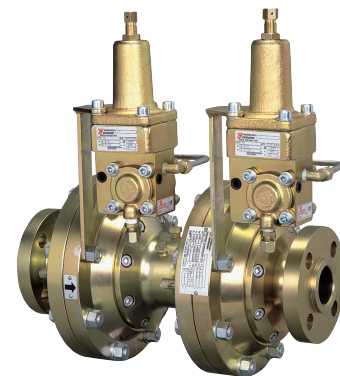

TYPE MFL

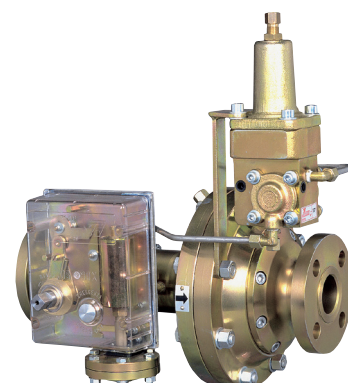

TYPE BFL

Introduction

The FL-BP Series regulators are accurate pilot-operated, pressure balanced, soft seated regulators designed for low-pressure transmission/city gate, large capacity distribution systems, and power plant feeds.

The FL-BP Series provides smooth and quiet operation, tight shutoff, and long life.

The FL-BP Series is in conformity with the Pressure Equipment Directive PED 2014/68/UE and is classified under Category IV.

Available Configurations

Type FL-BP:

Low Pressure Regulator or Monitor

Type MFL-BP:

Low Pressure Regulator + Monitor

Type BFL-BP:

Low Pressure Regulator + Shutoff

All FL-BP type regulators are available with or without:

Type SR: Silencer

Type SRS: Silencer with widened outlet flange

A widened outlet version without built-in silencer is also available.

Body Sizes

FL-BP Series:

DN 25, 40, 50, 65, 80, 100, 150*, 200* and 250*
(NPS 1, 1-1/2, 2, 2-1/2, 3, 4, 6*, 8* and 10*)

FL-BP Series with Type SRS Silencer or Widened Outlet:

DN 25 x 100, 40 x 150, 50 x 150, 65 x 200, 80 x 250, 100 x 250, and 150 x 300*
(NPS 1 x 4, 1-1/2 x 6, 2 x 6, 2-1/2 x 8, 3 x 10, 4 x 10, and 6 x 12*)

* These sizes are not available in MFL and BFL configurations.

End Connection Styles

PN 16, 25 / CL150

Inlet Pressure Ranges

Allowable Pressure: Up to 25 bar

Inlet Pressure Range: 0.2 to 25 bar

Outlet Pressure Range

0.01 to 8 bar

Minimum Operating Differential Pressure

0.2 bar

Accuracy Class

Up to $\pm 1\%$

Lock-Up Pressure Class

Up to +5%

Class of Lock-Up Pressure Zone

Up to 5%

Built-In Shutoff Valve

Independent Pneumatic Control

Manual Reset

Accuracy Group: Up to $\pm 1\%$

Response Time: ≤ 1 s

Temperature Capabilities

Standard Version:

Working: -10° to 60° °C

Low Temperature Version:

Working: -20° to 60° °C

Approximate Weights (Including Pilot)

24 to 380 kg

Features

- No Atmospheric Bleed
- Quiet Operation
- Control Accuracy
- Versatility
- Easy In-Line Maintenance
- Tight Shutoff
- High Capacity
- In-Service Travel Indicator

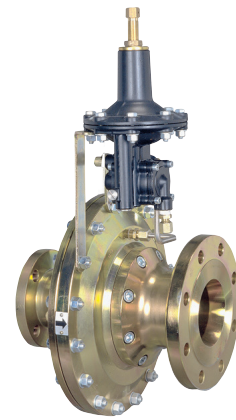

TYPE FL-BP

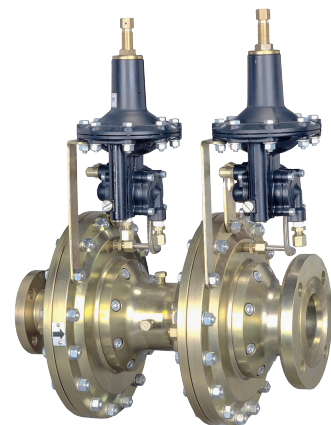

TYPE MFL-BP



TYPE BFL-BP



FL-FR Series

Pilot-Operated Pressure Reducing Regulators - French Market Only

TARTARINI™

Introduction

The FL-FR Series regulators are accurate pilot-operated, pressure balanced, soft seated regulators designed for high-pressure transmission/city gate, large capacity distribution systems, and power plant feeds.

The FL-FR Series provides smooth and quiet operation, tight shutoff, and long life.

The FL-FR Series is in conformity with the Pressure Equipment Directive PED 2014/68/UE and is classified under Category IV.

Available Configurations

Type FL-FR-BP:

Low Pressure Regulator or Monitor

Type FL-FR-HP:

High Pressure Regulator or Monitor

Type MFL-FR-BP:

Low Pressure Regulator + Monitor

Type MFL-FR-HP:

High Pressure Regulator + Monitor

All FL-FR type regulators are available with or without:

Type SR / SRII: Silencer

Type SRS / SRSII: Silencer with widened outlet flange

A widened outlet version without built-in silencer is also available.

Body Sizes

FL-FR Series:

DN 25, 50, 80, 100, 150*, 200*, and 250* (NPS 1, 2, 3, 4, 6*, 8*, and 10*)

FL-FR Series with Type SRS / SRSII Silencer or Widened Outlet:

DN 25 x 100, 50 x 150, 80 x 250, 100 x 250, 150 x 300*, 200 x 400* and 250 x 500* (NPS 1 x 4, 2 x 6, 3 x 10, 4 x 10, 6 x 12*, 8 x 16* and 10 x 20*)

* These sizes are not available in MFL-FR configurations.

End Connection Styles

FL-FR-BP: PN 16, 25 / CL150

FL-FR-HP: CL300, and CL600

Inlet Pressure Ranges

FL-FR-BP:

Allowable Pressure: Up to 25 bar

Inlet Pressure Range: 0.2 to 25 bar

FL-FR-HP:

Allowable Pressure: Up to 100 bar

Inlet Pressure Range: 1 to 100 bar

Outlet Pressure Range

FL-FR-BP: 0.01 to 8 bar

FL-FR-HP: 0.5 to 80 bar

Minimum Operating Differential Pressure

FL-FR-BP: 0.2 bar

FL-FR-HP: 0.5 bar

Accuracy Class

Up to ±1%

Lock-Up Pressure Class

Up to +5%

Class of Lock-Up Pressure Zone

Up to 5%

Temperature Capabilities

Working: -20° to 60 °C

Approximate Weights (Including Pilot)

FL-FR-BP: 24 to 380 kg

FL-FR-HP: 31 to 1190 kg

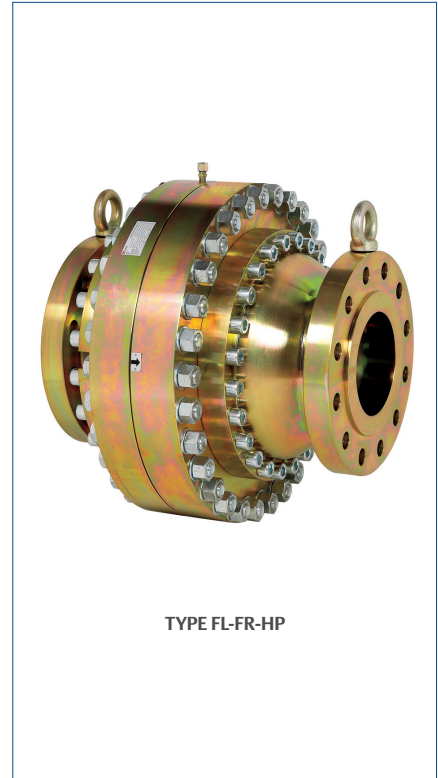

TYPE FL-FR-HP

Features

- No Atmospheric Bleed
- Quiet Operation
- Control Accuracy
- Versatility
- Easy In-Line Maintenance
- Tight Shutoff
- High Capacity

Introduction

The Cronos Series regulators are accurate pilot-operated, pressure balanced, soft seated regulators designed for high pressure transmission/city gate stations, large capacity distribution systems, and power plant feeds.

They provide smooth and quiet operation, tight shutoff and long life. The regulator utilizes a main valve actuator, a type PRX pressure reducing pilot with a type SA/2 pilot supply regulator or a type PS pressure reducing pilot.

The Cronos Series is in conformity with the Pressure Equipment Directive PED 2014/68/UE and is classified under Category IV.

Available Configurations

- Type C:** Regulator
- Type CB:** Regulator + Shutoff
- Type CBB:** Regulator + Shutoff + Shutoff
- Type CC:** Regulator + Monitor
- Type CCB:** Regulator + Monitor + Shutoff
- Type CBS:** 90° Flow Regulator + Shutoff
- Type CCS:** 90° Flow Regulator + Monitor
- Type CCBS:** 90° Flow Regulator + Monitor + Shutoff

All Cronos type regulators are available with or without:

- Type SR:** Silencer
- Type SRS:** Silencer with widened outlet flange

A widened outlet version without built-in silencer is also available.

Body Sizes

Cronos Series:

DN 25, 50, and 80 (NPS 1, 2, and 3)
Note: Type CBB DN 50 only

Cronos Series with Type SRS Silencer or Widened Outlet:

DN 25 x 100, 50 x 150, and 80 x 250
(NPS 1 x 4, 2 x 6, and 3 x 10)
Note: Type CBB DN 50x150 only

End Connection Styles

PN 16, 25, 40 / CL150, CL300, and CL600

Inlet Pressure Ranges

Flange Rating PN 16 / CL150:

Allowable Pressure: Up to 20 bar
Inlet Pressure Range: 0.2 to 20 bar

Flange Rating PN 25, 40 / CL300, CL600:

Allowable Pressure: Up to 100 bar
Inlet Pressure Range: 1 to 100 bar

Outlet Pressure Ranges

Flange Rating PN 16 / CL150:

0.01 to 16 bar

Flange Rating PN 25, 40 / CL300, CL600:

0.5 to 80 bar

Minimum Operating Differential Pressures

Flange Rating PN 16 / CL150:

0.2 bar

Flange Rating PN 25, 40 / CL300, CL600:

0.5 bar

Accuracy Class

Up to ±1%

Lock-Up Pressure Class

Up to +5%

Class of Lock-Up Pressure Zone

Up to 5%

Built-In Shutoff Valve

Independent Pneumatic Control
Manual Reset

Accuracy Group: Up to ±1%

Response Time: ≤1 s

Temperature Capabilities

Standard Version:

Working: -10° to 60 °C

Low Temperature Version:

Working: -20° to 60 °C

Approximate Weights (Including Pilot)

36 to 427 kg



TYPE CCB-SRS

TYPE CCBS

Features

- Control Accuracy
- Versatility
- Tight Shutoff
- No Atmospheric Bleed
- High Capacity
- In Service Travel Indicator
- Silencer Options



Cronos-FR Series

Pilot-Operated Pressure Reducing Regulators - French Market Only

TARTARINI™

Introduction

The Cronos-FR Series regulators are accurate pilot-operated, pressure balanced, soft seated regulators designed for high pressure transmission/city gate stations, large capacity distribution systems and power plant feeds.

They provide smooth and quiet operation, tight shutoff and long life.

The regulator utilizes a main valve actuator, and a Compact Pilot system.

The Cronos-FR Series is in conformity with the Pressure Equipment Directive PED 2014/68/UE and is classified under Category IV.

Available Configurations

Type C-FR: Regulator

Type CB-FR: Regulator + Shutoff

Type CC-FR: Regulator + Monitor

All Cronos-FR type regulators are available with or without:

Type SR: Silencer

Type SRS: Silencer with widened outlet flange

Body Sizes

Cronos-FR Series:

DN 25, 50, and 80
(NPS 1, 2, and 3)

Cronos-FR Series with Type SRS Silencer:

DN 25 x 100, 50 x 150, and 80 x 250
(NPS 1 x 4, 2 x 6, and 3 x 10)

End Connection Style

PN 25

Inlet Pressure

Allowable Pressure: 25 bar
Inlet Pressure Range: 0.8 to 25 bar

Outlet Pressure Range

0.01 to 16 bar

Minimum Operating Differential Pressure

1 bar

Maximum Operating Differential Pressure

24 bar

Accuracy Class

Up to ±1%

Lock-Up Pressure Class

Up to +5%

Class of Lock-Up Pressure Zone

Up to 5%

Built-In Shutoff Valve

Independent Pneumatic Control

Manual Reset

Accuracy Group: Up to ±2,5%

Response Time: ≤1 s

Temperature Capabilities

Working: -20° to 60 °C

Approximate Weights (Including Pilot)

36 to 213 kg

Features

- Control Accuracy
- Versatility
- Tight Shutoff
- No Atmospheric Bleed
- High Capacity
- In Service Travel Indicator
- Silencer Options

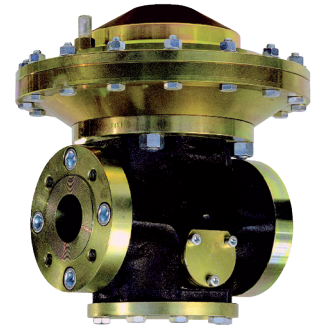

TYPE C-FR

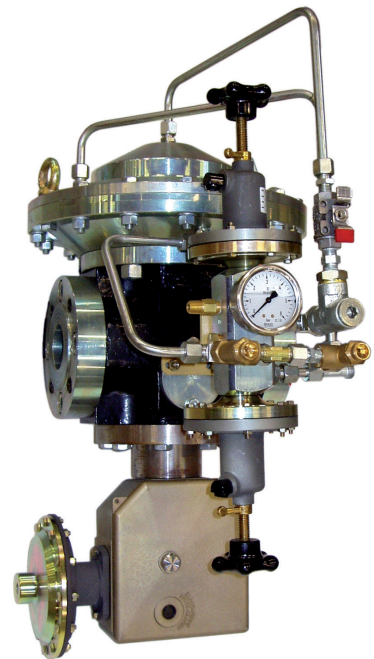

TYPE CB-FR

Introduction

Type EZH and EZHSO series regulators are accurate pilot-operated, pressure balanced, soft-seated regulators.

They are designed for use in high pressure natural gas transmission/city gate stations, large capacity distribution systems, and power plant feeds. They provide smooth and reliable operation, tight shutoff and long life.

The EZH and EZHSO Series are in conformity with the Pressure Equipment Directive PED 2014/68/UE and are classified under Category IV.

Available Configurations

Type EZH:

Spring-to-Close pilot-operated pressure reducing regulator for low to high outlet pressure

Type EZH-OS2:

Type EZH pressure reducing regulator with an OS2 slam-shut device for overpressure or overpressure and underpressure protection

Type EZHSO:

Spring-to-Open pilot-operated pressure reducing regulator for low to high outlet pressure

Type EZHSO-OS2:

Type EZHSO pressure reducing regulator with an OS2 slam-shut device for overpressure or overpressure and underpressure protection

Body Sizes

DN 25, 50, 80, 100, 150 and 200
(NPS 1, 2, 3, 4, 6 and 8)

End Connection Styles

PN 16 B, 25 B, 40 B
CL150, CL300 and CL600

Inlet Pressure Ranges

Allowable Pressure: Up to 100 bar
Inlet Pressure Range: 1 to 100 bar

Outlet Pressure Range

1 to 80 bar

Minimum Operating Differential Pressures

Type EZH: 1 bar

Type EZHSO: 3.8 bar

Maximum Operating Differential Pressures

Type EZH: 99 bar

Type EZHSO: 96.2 bar

Temperature Capabilities

Working: -20° to 60 °C

Approximate Weights (Including Pilot)

36 to 263 kg

Features

- Long Life in Severe Service Applications
- High Resistance to Aromatics and Particle Erosion
- Noise Attenuation Module (optional)
- High Turn Down Capacity for Systems with Large Variations in Downstream Flow Demand
- Absolutely No Bleed to Atmosphere
- Wide Range of Flow Coefficients for each Body Size
- Bubble Tight Shutoff
- Accurate Pressure Control
- Low Temperature Standard Version
- Integral Strength
- Easy Maintenance System for DN 100 Size
- Spring-to-Close and Spring-to-Open Versions

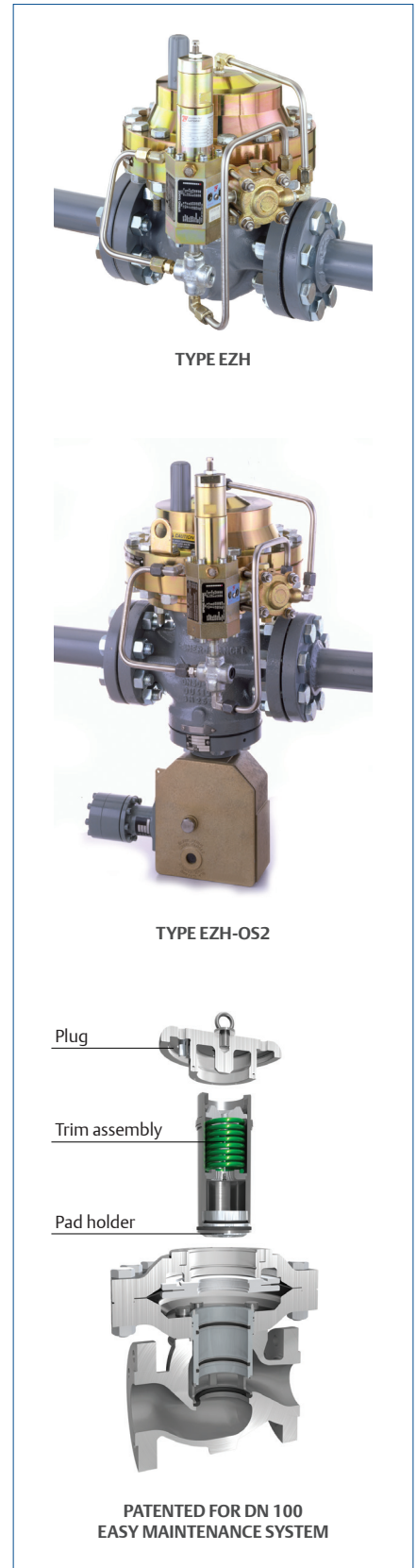

Introduction

The type 971 regulators feature simple seat and counterbalanced valve.

The “top entry” design allows easy maintenance operations without disassembling the regulator from the line.

They assure high accuracy of the regulated pressure even when the inlet pressure is extremely variable.

The 971 type is in conformity with the Pressure Equipment Directive PED 2014/68/UE and is classified under Category III.

Available Configurations

Type 971: Regulator

Type 971-E: Monitor

The type 971 regulator is available with type SR silencer.

Body Size

DN 250 (NPS 10)

End Connection Styles

CL300, CL600

Inlet Pressure Ranges

Allowable Pressure: Up to 100 bar

Inlet Pressure Range: 1 to 100 bar

Outlet Pressure Range

0.5 to 70 bar

Minimum Operating Differential Pressure

0.5 bar

Accuracy Class

Up to ±1%

Lock-Up Pressure Class

Up to +5%

Class of Lock-Up Pressure Zone

Up to 5%

Temperature Capabilities

Standard Version:

Working: -10° to 60 °C

Low Temperature Version:

Working: -20° to 60 °C

Approximate Weight (Including Pilot)

1700 kg



Features

- Accuracy Maintained with Variable Inlet Pressure
- Easy Set-point Adjustment
- High Versatility for Different Applications

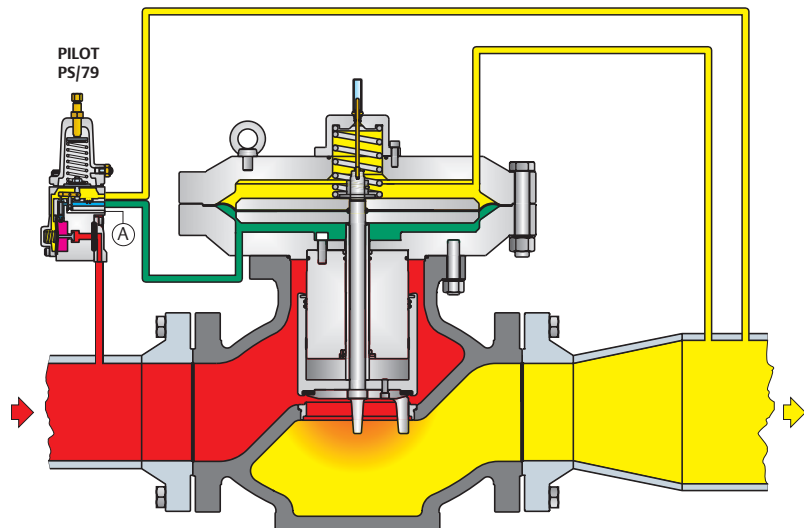

TYPE 971 OPERATIONAL SCHEMATIC

LEGEND

■ INLET PRESSURE

■ LOADING PRESSURE

■ OUTLET PRESSURE

Ⓐ DOWNSTREAM OR TO A SAFE AREA

Introduction

The type EZR pilot-operated, pressure reducing regulator designed to give accurate, smooth, quiet operation, tight shut-off, and long life, even in dirty service.

It is also available with a slam-shut device, the type EZR-OS2, which can provide either overpressure protection or overpressure and underpressure protection by completely shutting off the flow of gas to the downstream system.

The EZR Series can be installed in various natural gas applications such as transmission/distribution systems, industrial and commercial facilities.

The EZR Series is in conformity with the Pressure Equipment Directive PED 2014/68/UE and is classified under Category IV.

Available Configurations

Type EZR (Boot Style):

Pilot-operated pressure reducing regulator for low to high outlet pressure

Type EZR-OS2:

Type EZR with slam-shut device for overpressure (OPSO) or overpressure and underpressure (OPSO/UPSO) protection

Temperature Capabilities

-17° to 66°C

Approximate Weights (Including Pilot)

Type EZR:

12 to 161 kg

Type EZR-OS2:

20 to 244 kg

Features

- Tight Shutoff
- Versatility
- Easily Maintained Pilots
- Full Usable Capacity
- Easy Maintenance
- High Accuracy Pressure Control

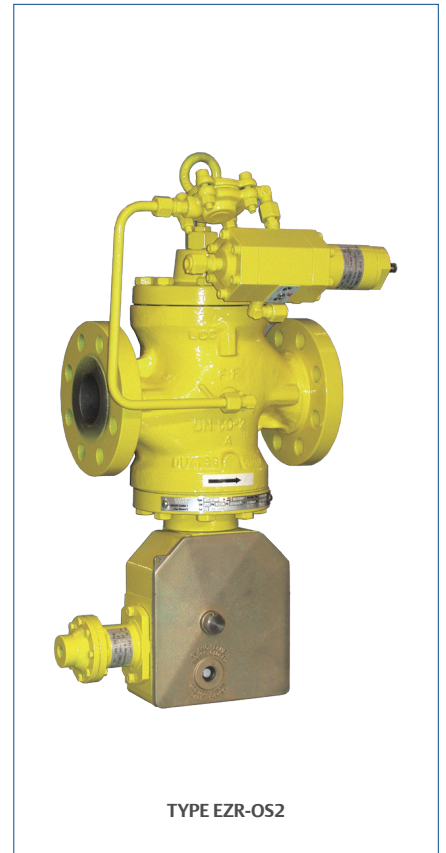

TYPE EZR-OS2

Body Sizes

DN 25, 50, 80, 100, and 150
(NPS 1, 2, 3, 4, and 6)

End Connection Styles

PN 16 B, 25 B, 40 B
CL150, CL300, and CL600

Maximum Operating Inlet Pressure

72.4 bar

Maximum Operating Differential Pressure

55.2 bar

Minimum Operating Differential Pressure

3 bar

Outlet Pressure Range

10 mbar to 69 bar

Pressure Registration

External

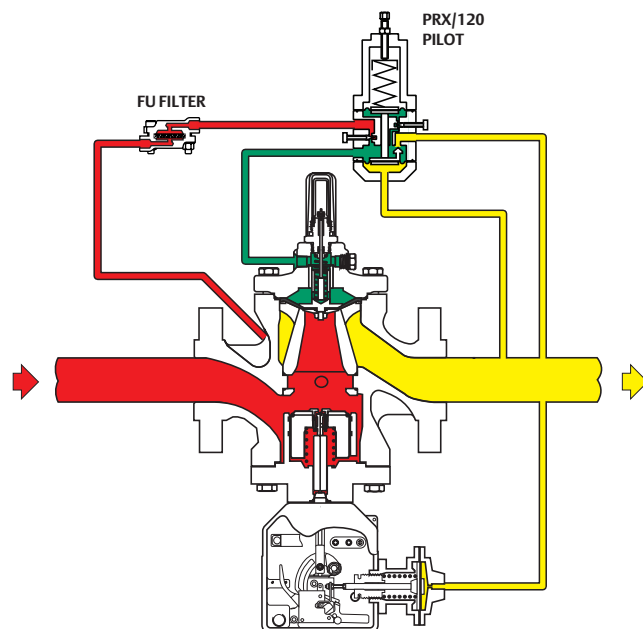

TYPE EZR-OS2 OPERATIONAL SCHEMATIC

LEGEND

■ INLET PRESSURE

■ LOADING PRESSURE

■ OUTLET PRESSURE

Introduction

The PS Series pilots are mainly used in natural gas applications. All PS Series pilots are supplied with a filter (5µ filtering degree) and built-in pressure stabilizer, with the exception of pilots types PSO/79 and PSO/80. The PS and RE Series pilots can be installed in the following equipment:

FL Series - Cronos Series - Type 971

Available Configurations

High-Pressure Pilot Range

Type PS/79: Single diaphragm pilot for pressure regulator (active or wide-open monitor)

Type PSO/79: Single diaphragm pilot for setting of first pressure-reducing step (upstream) of pressure regulator (working monitor)

Type REO/79: Single diaphragm pilot for setting of second pressure-reducing step (downstream) of pressure regulator (working monitor)

Type PS/80: Double diaphragm pilot for pressure regulator (active or wide-open monitor)

Type PSO/80: Double diaphragm pilot for setting of first pressure-reducing step (upstream) of pressure regulator (working monitor)

Type REO/80: Double diaphragm pilot for setting of second pressure-reducing step (downstream) of pressure regulator (working monitor)

Low-Pressure Pilot Range

Type PS/79-1: Single diaphragm pilot for pressure regulator (0.01 - 0.5 bar)

Type PS/79-2: Single diaphragm pilot for pressure regulator (0.5 - 3 bar)

Type PSO/79-1: Single diaphragm pilot for setting of first pressure-reducing step (upstream) of pressure regulator (working monitor) (0.01 - 0.5 bar)

Type PSO/79-2: Single diaphragm pilot for setting of first pressure-reducing step (upstream) of pressure regulator (working monitor) (0.5 - 3 bar)

Type REOPS/79-1: Single diaphragm pilot for setting of second pressure-reducing step (downstream) of pressure regulator (working monitor) (0.01 - 0.5 bar)

Type REO/79-2: Single diaphragm pilot for setting of second pressure-reducing step (downstream) of pressure regulator (working monitor) (0.5 - 3 bar)

Type PS/80-1: Double diaphragm pilot for pressure regulator (active or wide-open monitor)

End Connection Styles

1/4" NPT female threaded

Pressure Ratings

Type PS/79, PSO/79, REO/79:

Allowable Pressure: 100 bar
Set Range: 0.5 to 40.0 bar

Type PS/80, PSO/80, REO/79:

Allowable Pressure: 100 bar
Set Range: 1.5 to 40.0 bar

PS/79-1 - RE/79-1 - PSO/79-1 - REOPS/79-1:

Allowable Pressure: 20 bar
Set Range: 0.01 to 0.5 bar

Type PS/79-2, PSO/79-2, REO/79-2:

Allowable Pressure: 20 bar
Set Range: 0.5 to 3 bar

Type PS/80-1:

Allowable Pressure: 25 bar
Set Range: 0.01 to 0.5 bar

Temperature Capabilities

Standard Version:

Working: -10° to 60 °C

Low Temperature Version:

Working: -20° to 60 °C

Weights

PS/79-1 PS/79-2 Series: 2.5 kg

PS/80-1: 3.8 kg

PS/79 Series: 8 kg

PS/80 Series: 9 kg

Features

- High Sensitivity
- Improved Performance
- High Accuracy



TYPE PS/79-1 OR PS/79-2



TYPE PS/79

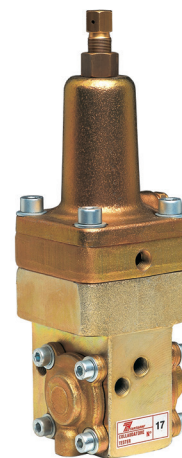

TYPE PS/80

Introduction

The PRX Series pilots are mainly used in natural gas applications.

They have a double diaphragm which provides increased accuracy and sensitivity, an integral damper adjustment to allow adjustable opening and closing speeds, and a restrictor adjustment to allow adjustments to make for inlet pressure variability and loading pressure oscillations.

The type SA/2 stabilizer filter must be used with PRX/120 series pilots when the PRX/120 are installed in FL, Cronos, 971 and EZH series regulators.

The PRX Series pilots can be installed in the following equipment:

- FL Series
- Cronos Series
- EZH Series
- EZR Series
- Type 971
- VS-FL Series
- BM5 Series
- BM6X Series

Available Configurations

Types PRX/120 and PRX-AP/120:

Pilots for Regulator or Monitor Control

Types PRX/125 and PRX-AP/125:

Pilots for Working Monitor Control

Types PRX/181-PN, PRX-AP/181-PN, PRX/182-PN and PRX-AP/182-PN:

Pilots for OS/80X-PN Slam-Shut Device

Types PRX/131 and PRX-AP/131:

Pilots for Booster Valve

Type PRX/182 and PRX-AP/182:

Pilots for Relief Valve

End Connection Styles

1/4" NPT female threaded

Pressure Ratings

Types PRX/120 and PRX/125:

Allowable Pressure: 100 bar

Set Range: 1 to 40 bar

Types PRX-AP/120 and PRX-AP/125:

Allowable Pressure: 100 bar

Set Range: 30 to 80 bar

Types PRX/131, PRX/182, PRX/181-PN, and PRX/182-PN:

Allowable Pressure: 100 bar

Set Range: 0.5 to 40 bar

Types PRX-AP/131, PRX-AP/182, PRX-AP/181-PN, and PRX-AP/182-PN:

Allowable Pressure: 100 bar

Set Range: 30 to 80 bar

Temperature Capabilities

Standard Version:

Working: -10° to 60 °C

Low Temperature Version:

Working: -20° to 60 °C

Weights

PRX Series: 2.3 kg

PRX-AP Series: 2.5 kg

SA/2: 1.5 kg

Features

- High Sensitivity
- Improved Performance
- High Accuracy
- Easy Setting



TYPE PRX



TYPE PRX-AP



TYPE SA/2

Introduction

Two Standard Pilot Systems are available:

Type BSL85/1 - Distribution applications
Composed of a manometric pre-expansion box, a manometric pre-expansion pilot box, and a pilot body.

Type BSL85/2 - Transmission applications
Composed of a manometric pre-expansion box, a manometric pre-expansion pilot box and two pilot bodies. The BSL85/2 permits all types of failure modes.

- The BMP pilots with standard diaphragm are "FO"
- The BMP pilots with double diaphragm are "FC"
- The bellows are flattened in the case of overpressure but with no leak to the outside

Different connection types permit these pilots to be used on a wide range of Emerson pilot-operated regulators:

Type BSL85/1 - Distribution applications:
Cronos-FR, FL-FR, EZR

Type BSL85/2 - Transmission applications:
EZH, EZHSO, EZHFO, FL-FR, EZR

Two functional types of pressure reduction are available, Hard Trim or Boot Trim Pilot System:

- Pressure reduction with actuator and plug: pilot system loaded by modulated pressure
- Pressure reduction with diaphragm-plug: pilot system unloaded by modulated pressure

The setpoint range can be modified by simply changing the BMP manometric box or spring.

End Connection Style

1/4" NPT female threaded

Pressure Ratings

Maximum Inlet Pressure: 100 bar

Allowable Inlet Pressure: 85 bar

Outlet Pressure Range: 0.01 to 60 bar

Temperature Capabilities

Working: -20° to 60 °C

Features

- Ease of Maintenance
- Very Low Outlet Pressure Capability
- High Accuracy

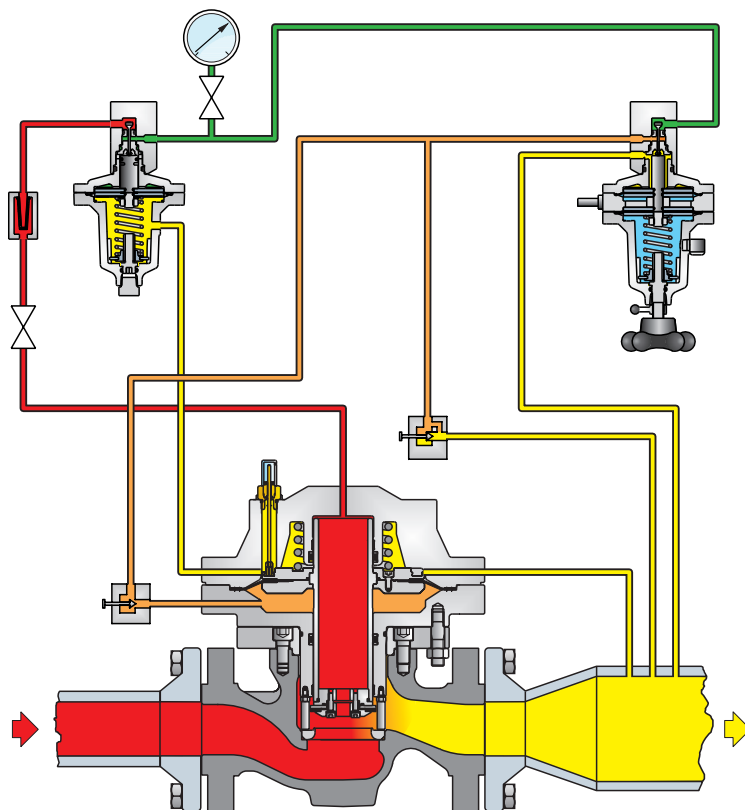

TYPE EZH REGULATOR WITH TYPE BSL 85/2 PILOT OPERATIONAL SCHEMATIC

LEGEND

- | | | |
|---|---|--|
| ■ INLET PRESSURE | ■ MODULATED PRESSURE | ■ ATMOSPHERIC PRESSURE |
| ■ OUTLET PRESSURE | ■ PILOT FEEDING PRESSURE | |

Introduction

In monitor-regulator systems the booster valve V/31-2 is installed on the loading pressure circuit, in order to obtain a more rapid action in monitor closing.

La V/31-2 can be installed in the following equipment:

- FL Series
- Cronos Series
- EZH Series

End Connection Styles

1/4" NPT female threaded

Pressure Ratings

Allowable Pressure: 19 bar
Set Range: 0.015 to 0.55 bar

Temperature Capabilities

Standard Version:

Working: -10° to 60 °C

Low Temperature Version:

Working: -20° to 60 °C

Weight

2.5 kg

Features

- High Sensitivity
- Improved Performance
- High Accuracy



V/31-2

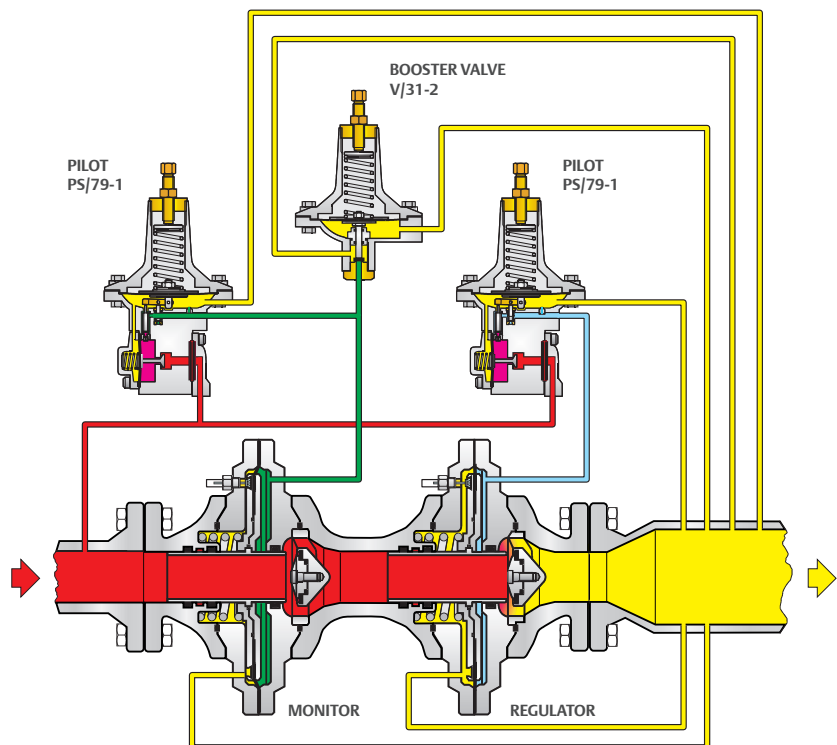

TYPE MFL MONITOR AND REGULATOR OPERATIONAL SCHEMATIC

LEGEND

- INLET PRESSURE
- MONITOR LOADING PRESSURE
- OUTLET PRESSURE
- REGULATOR LOADING PRESSURE

Introduction

The type RPE electric pilot heater is used for reheating gas supplying pressure reducing regulator pilots.

The type RPE avoids the inconveniences caused by freezing which occur during large pressure drops.

The RPE is in conformity with the Directive for Equipment or protective system intended for use in potentially explosive atmospheres 2014/34/UE. It is classified under group II, category 2.

Two versions of the type RPE are available:

Electrical Pilot Heater

The type RPE (with a heating element) is installed in a vertical position and is affixed to the actuator bolts of the regulator.

The type RPE can be installed in a hazardous atmosphere and must be installed between the pilot filter and the pre-expansion relay.

A thermostat and power relay must be installed in a non-explosive risk zone.

Regulator Bottom Electrical Heater

This version is normally used for relief lines. The Type RPE is assembled with four screws to the bottom of the regulator.

Electrical Material for Explosive Atmosphere

Protection: Ex db IIC T2 Gb

Classification: CML 18 ATEX 1081

Maximum Operating Pressure

Thermometer Pocket with Heating Element: 100 bar

Temperature Measurement

Interchangeable Thermic Probe: 10 kΩ

Heater

Two Interchangeable Heating Cartridges: 280 W - 230 V

Connected in Series: 140 W

Temperature Regulation Range

Thermostat: -30 to 90° C

Power Supply

Power Relay: I max: 2 A ; U: 250 V~

Protection

Thermostat: 2 A

Power Relay: 2 A

Pneumatic Connections

Inlet - Outlet: 1/4 NPT - tube 8/10

Electrical Connections

Electrical Type RPE Box: Packing gland 3/4 NPT for cable snap-on

Weights

Heater: 1.4 kg

Heater with Heating Element: 4.5 kg



Features

- Robust Design
- Large Range of Utilization

Introduction

Silencers are noise reduction system devices which are commonly installed in a regulator as a remedy for noise pollution.

Available Configurations

Type SR:

This silencer is fitted near the regulator shutter and is highly efficient up to a theoretical speed of 80 m/s calculated at the outlet flange.

Higher than this speed, noise may be generated by the expansion cone, usually installed downstream of the regulator, and may require an additional noise reduction solution.

Type SRII:

The SRII silencer is the next generation of type SR and is used in case of extreme service conditions (dirty gas, high pressure drops, and high gas velocities).

Noise characteristics are very similar to the standard SR.

Type SRS and SRSII:

The SRS consists of an SR silencer plus a widened outlet flange in which a second silencer is fitted.

The SRSII consists of an SRII silencer plus a widened outlet flange in which a second silencer is fitted.

In both configurations the second silencer has an initial multi-path section and a second multi-stage section.

These silencers are highly efficient under all operating conditions and are not limited by the theoretical speed on the regulator outlet flange.

Type STP:

Usually used downstream of SRS or SRSII silencers but can also be combined with a SR silencer.

Overall reduction in noise level is the sum of the reduction produced by SR/SRII or SRS/SRSII plus the STP induced reduction. The type STP silencer consists of one or more porous channels clad with soundproofing material.

Sound penetrates inside the soundproof layer and is transformed into heat by friction of the gas flow.

The silencer is fitted in the pipe and is secured with two flanges.

Two types of silencers are available:

- STP10 10 dB (A) attenuation, approximate length of 1 m
- STP10 20 dB (A) attenuation, approximate length of 2 m

Features

- Various Noise Reduction Solutions
- Excellent Cost / Benefit Ratio



TYPE SR



TYPE SRII

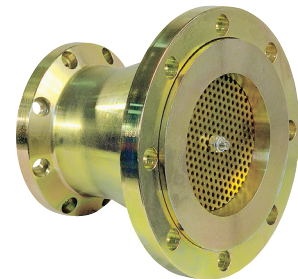

TYPE SRS AND SRSII



TYPE STP

Introduction

The type RP/10 regulators are normally employed in pressure reducing stations using high pressure gas compressed in cylinders.

They can also be employed with middle pressure gas in ceramic, chemical, and pharmaceutical factories for small furnaces.

Type RP/10 is in conformity with the Pressure Equipment Directive PED 2014/68/UE and is classified under Category I.

Body Size and End Connection Style

3/4" x 1" BSP

Inlet Pressure

Body Allowable Pressure: 220 bar

Maximum Operating Pressure: 30 bar

Inlet Pressure Range: 1 to 220 bar

Outlet Pressure Range

0.5 to 30 bar

Accuracy Class

Up to ±5%

Lock-up Pressure Class

Up to 10%

Class of Lock-Up Pressure Zone

Up to 10%

Temperature Capabilities

Working: -10° to 60 °C

Orifice Size

1/2"

Approximate Weight

17 kg

Features

- Counterbalanced Valve Disc
- Tight Shutoff
- Built-in Spring Operated Safety Valves

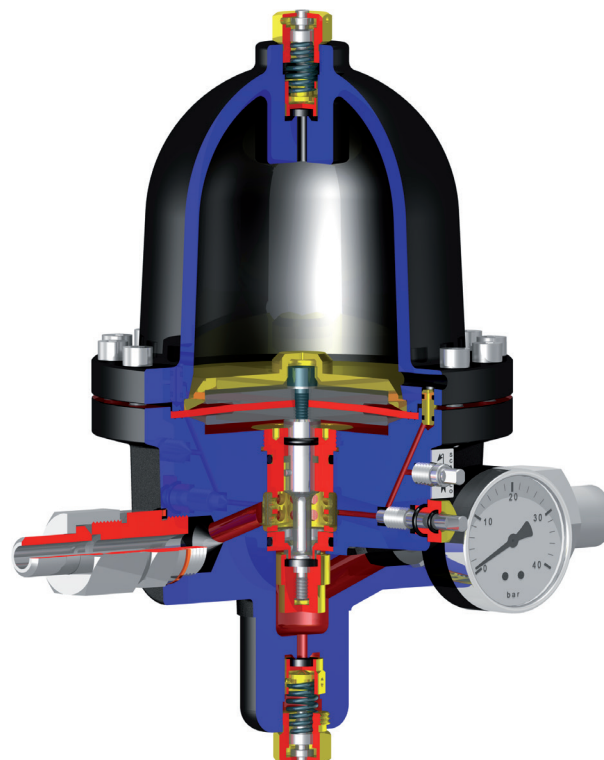

INTERNAL VIEW OF THE TYPE RP/10

Introduction

The type RLC/20 regulators are pneumatic-loaded, single seated, with counterbalanced valve disc.

They are normally employed in gas distributing stations for automotive use.

They can also be used in industrial installations using high pressure gas compressed in cylinders and cylinder-truck installations normally fed through the pipeline.

Body Size and End Connection Style

1" NPT Threaded
DN 20 PN 350 Flanged

Inlet Pressure

Body Allowable Pressure: 320 bar
Maximum Operating Pressure: 250 bar
Inlet Pressure Range: 30 to 320 bar

Outlet Pressure Range

20 to 250 bar

Minimum Operating Differential Pressure

10 bar

Accuracy Class

Up to ±2.5%

Lock-Up Pressure Class

Up to 5%

Class of Lock-Up Pressure Zone

Up to 10%

Built-In Relief Valve

Setting at +5% of the regulator setting value

Orifice Size

3/4"

Temperature Capabilities

Standard Version:

Working: -10° to 60 °C

Low Temperature Version:

Working: -20° to 60 °C

Approximate Weight

100 kg

Features

- Counterbalanced Valve Disc
- Welding or Threaded Flange Configurations
- Built-in Relief Valve and Filter

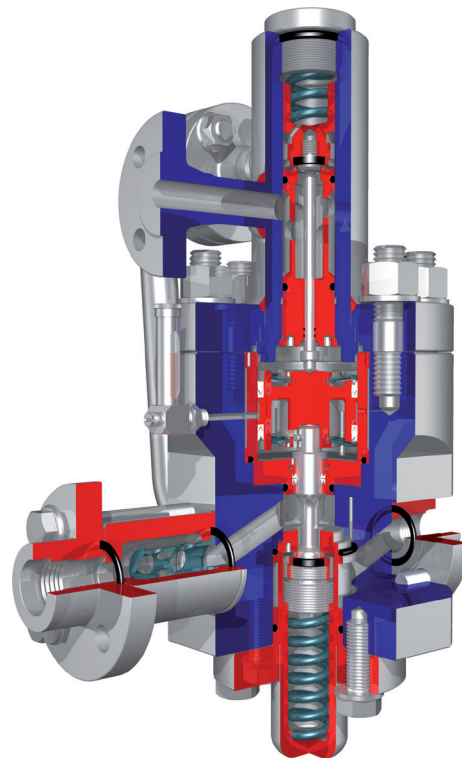

INTERNAL VIEW OF THE TYPE RLC/20

Introduction

The technical and operational features of the M Series, spring-loaded regulators, make them ideal for applications requiring sudden changes in capacity or where gas shutoff is solenoid-controlled as with domestic or industrial burners.

The MF and MN MR Series are in conformity with the Pressure Equipment Directive PED 2014/68/UE and are classified under Category IV maximum.

Available Configurations

MN Series (Widened Outlet Flanges)

Types MN, MN-AP, MN-APA, and MN-PST: Regulator

Types MBN, MBN-AP, MBN-APA, and MBN-PST: Regulator + Shutoff

Types MBN-M, MBN-M-AP, MBN-M-APA, and MBN-M-PST: Monitor + Shutoff

MF Series (Same Inlet/Outlet Flanges)

Types MF, MF-AP, MF-APA, and MF-PST: Regulator

Types MBF, MBF-AP, MBF-APA, and MBF-PST: Regulator + Shutoff

Types MBF-M, MBF-M-AP, MBF-M-APA, and MBF-M-PST: Monitor + Shutoff

All MN and MF type regulators, or regulators + shutoff, are available with or without type SR Silencer.

Body Sizes

MN Series:

DN 25 x 65, 40 x 80, 50 x 100, 65 x 100, 80 x 150, and 100 x 200 (NPS 1 x 2-1/2, 1-1/2 x 3, 2 x 4, 2-1/2 x 4, 3 x 6, and 4 x 8)

MF Series:

DN 25, 40, 50, 80, and 100 (NPS 1, 1-1/2, 2, 3, and 4)

End Connection Style

PN 16 / CL150

Inlet Pressure

Body Allowable Pressure: Up to 20 bar
 Actuator Allowable Pressure: 4 bar
 Maximum Operating Pressure: 3 bar

Permissible Inlet Pressure:

Standard Version
 DN 25 to 50 (NPS 1 to 2): 10 bar
 DN 65 to 100 (NPS 2-1/2 to 4): 5 bar
 PST, AP and APA Versions: 19.6 bar

Outlet Pressure Range

Standard Version: 10 to 500 mbar
 PST Version: 0.2 to 0.5 bar
 AP Version: 0.5 to 1 bar
 APA Version: 1 to 3 bar

Accuracy Class

Up to ±5%

Lock-up Pressure Class

Up to 10%

Class of Lock-up Pressure Zone

Up to 10%

Built-in Slam-Shut Valve

Independent Pneumatic Control
 Accuracy Group: ±5%
 Response Time: <1 s

Temperature Capabilities

Working: -10° to 60 °C
 Low temperature version available on request.

Approximate Weights

31 to 140 kg

Features

- Counterbalanced Shutter
- Overpressure and Underpressure Shutoff Valve
- Wide Pressure Regulation Range
- Manual Reset



TYPE MF

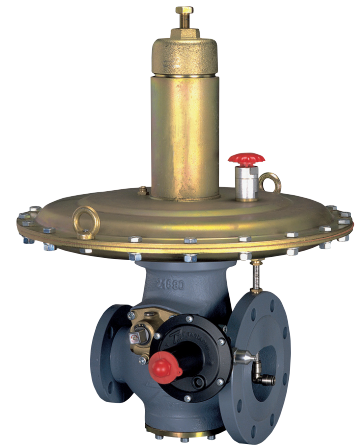

TYPE MBN

Introduction

The A/100 Series regulators ensure precise stable operation even when the requirements of the plant cause exceptionally unfavorable conditions such as rapid fluctuations in demand.

These regulators are commonly used on industrial burners, with starting controlled by solenoid valves (on-off).

The A/100 Series is in conformity with the Pressure Equipment Directive PED 2014/68/UE and is classified under Category I.

Available Configurations

Type A/102:

Regulator

Type A/102-AP:

High Pressure Regulator

Type A/109:

Regulator + Shutoff

Type A/109-AP:

High Pressure Regulator + Shutoff

Body Size and End Connection Style

2" BSP Threaded

Inlet Pressure

Body Allowable Pressure: Up to 20 bar

Maximum Operating Pressure: 300 mbar

Maximum Inlet Pressure: 8 bar

Inlet Pressure Range: 0.1 to 8 bar

Outlet Pressure Range

10 to 300 mbar

Accuracy Class

Up to ±5%

Lock-Up Pressure Class

Up to 10%

Orifice Size

1/2", 5/8", 3/4", and 1"

Built-in Shutoff Valve

Independent Pneumatic Control

Accuracy Group: ±5%

Response Time: <1 s

Temperature Capabilities

Standard Version:

Working: -10° to 60 °C

Low Temperature Version:

Working: -20° to 60 °C

Approximate Weights

Type A/102, A/102-AP: 11 kg

Type A/109, A/109-AP: 12 kg

Features

- Built-in Relief Valve
- Overpressure and Underpressure Shutoff Valve
- Manual Reset
- Inlet and Outlet In-Line



TYPE A/102



TYPE A/109



TYPE A/109-AP

Introduction

Construction and performance features make the A/140 Series spring-loaded regulators the ideal choice in applications involving sudden changes in capacity, or where the gas shutoff is solenoid-controlled as with domestic or industrial burners.

The A/140 Series is in conformity with the Pressure Equipment Directive PED 2014/68/UE and is classified under Category IV maximum.

Available Configurations

Type A/142:

Regulator

Type A/142-AP:

High Pressure Regulator

Type A/149:

Regulator + Shutoff

Type A/149-AP:

High Pressure Regulator + Shutoff

Body Size and End Style Connection

DN 50 PN 16 (NPS 2)

Inlet Pressure

Body Allowable Pressure: Up to 20 bar

Maximum Operating Pressure: 300 mbar

Maximum Inlet Pressure: 6 bar

Inlet Pressure Range: 0.1 to 6 bar

Outlet Pressure Range

10 to 300 mbar

Accuracy Class

Up to ±5%

Lock-Up Pressure Class

Up to 10%

Orifice Size

13/16"

Built-in Shutoff Valve

Independent Pneumatic Control

Accuracy Group: ±5%

Response Time: <1 s

Temperature Capabilities

Standard Version:

Working: -10° to 60 °C

Low Temperature Version:

Working: -20° to 60 °C

Approximate Weights

Type A/142, A/142-AP: 19 kg

Type A/149, A/149-AP: 20 kg

Features

- Counterbalanced Valve
- Built-in Relief Valve
- Overpressure and Underpressure Shutoff Valve
- Manual Reset
- Inlet and Outlet In-Line

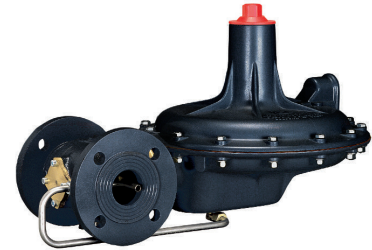

TYPE A/142



TYPE A/149



TYPE A/149-AP

Introduction

Construction and performance features make the B/240 Series spring-loaded regulators the ideal choice in applications involving sudden changes in capacity or where the gas shutoff is solenoid-controlled as with domestic or industrial burners.

The B/240 Series is in conformity with the Pressure Equipment Directive PED 2014/68/UE and is classified under Category IV maximum.

Available Configurations

Type B/242:

Regulator

Type B/242-AP:

High Pressure Regulator

Type B/249:

Regulator + Shutoff

Type B/249-AP:

High Pressure Regulator + Shutoff

Body Size and End Connection Style

1 1/2" BSP Threaded

DN 40 PN 16 (NPS 1-1/2) Flanged

Inlet Pressure

Body Allowable Pressure: Up to 20 bar

Maximum Operating Pressure: 300 mbar

Maximum Inlet Pressure: 6 bar

Inlet Pressure Range: 0.1 to 6 bar

Outlet Pressure Range

10 to 300 mbar

Accuracy Class

Up to ±5%

Lock-Up Pressure Class

Up to 10%

Orifice Size

13/16"

Built-in Shutoff Valve

Independent Pneumatic Control

Accuracy Group: ±5%

Response Time: <1 s

Temperature Capabilities

Standard Version:

Working: -10° to 60 °C

Low Temperature Version:

Working: -20° to 60 °C

Approximate Weights

Type B/242, B/242-AP: 3.5 kg

Type B/242-FS, B/242-AP-FS: 7.5 kg

Type B/249, B/249-AP: 4.5 kg

Type B/249-FS, B/249-AP-FS: 8.5 kg

Features

- Counterbalanced Valve
- Built-in Relief Valve
- Overpressure and Underpressure Shutoff Valve
- Manual Reset
- Inlet and Outlet In-line



TYPE B/242

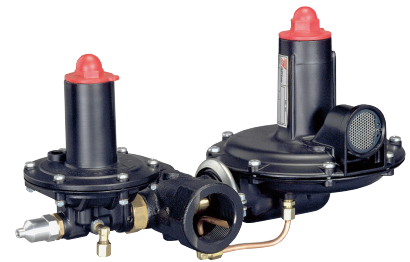

TYPE B/249

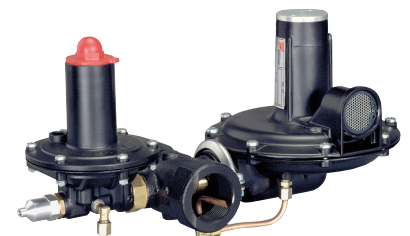

TYPE B/249-AP

Introduction

The RP Series regulators are direct-operated with non-balanced trim. Normally they are fitted with a built-in filter.

They are produced in the following version: types RP/011, RP/022, and RP/033. All models can be fitted with a shutoff valve.

The RP Series is in conformity with the Pressure Equipment Directive PED 2014/68/UE and is classified under Category I maximum.

Available Configurations

Types RP/011, RP/022, and RP/033:
Regulator

Types RP/011/66, RP/022/66, and RP/033/66:

Regulator + Shutoff

Body Sizes and End Connection Styles

Type RP/011:

1 x 1-1/4" BSP Threaded

Type RP/022:

1-1/4 x 2" BSP Threaded

Type RP/033:

2 x 3" BSP Threaded

Type RP/011-FS:

DN 25 x 32 PN 16, 25, 40 / CL150, CL300 Flanged

Type RP/022-FS:

DN 32 x 50 PN 16, 25, 40 / CL150, CL300 Flanged

Type RP/033-FS:

DN 50 x 80 PN 16, 25, 40 / CL150, CL300 Flanged

Inlet Pressure

Body Allowable Pressure: Up to 20 bar

Actuator Allowable Pressure: 4 bar

Maximum Inlet Pressure: 20 bar

Inlet Pressure Range: 0.2 to 20 bar

Outlet Pressure Ranges

Types RP/022 and RP/033:

0.1 to 4 bar

Type RP/011:

0.1 to 2 bar

Accuracy Class

Up to ±5%

Lock-Up Pressure Class

Up to 10%

Built-in Shutoff Valve

Independent Pneumatic Control

Accuracy Group: ±5%

Response Time: <1 s

Temperature Capabilities

Standard Version:

Working: -10° to 60 °C

Low Temperature Version:

Working: -20° to 60 °C

Approximate Weights

6 to 25 kg

Features

- Overpressure and Underpressure Shutoff Valve
- Manual Reset
- Inlet and Outlet In-line



TYPE RP/022



TYPE RP/033/66-FS

Introduction

The CSB400 Series direct-operated, spring-loaded regulators have been engineered to fit a multitude of pressure-reducing applications including commercial and industrial installations.

This flexibility is provided by the numerous body sizes and end connections, outlet pressure settings, as well as the option for internal, external, or dual pressure registration.

In addition to application flexibility, the CSB400 Series offers multiple overpressure protection options to meet your demands on application requirements.

The CSB400 Series is in conformity with the Pressure Equipment Directive PED 2014/68/UE. The base regulator is classified under Category I, the regulator with slam-shut module is classified under Category IV.

Body Sizes and End Connection Styles

Ductile Cast Iron:

1, 1-1/4, 1-1/2, or 2 NPT, Rp 1, 1 x 1-1/4, 1-1/4, 1-1/2, or 2, Rp 1 x 2-1/4 GAZ, NPS 1-1/2 (DN 40), PN16, NPS 2 (DN 50), CL125 FF, CL150 FF, or PN 10/16

Steel:

1, 1-1/4 or 1-1/2 NPT, Rp 1, 1-1/4 or 1-1/2

Maximum Operating Inlet Pressure Differential Strength

6 bar to 16 bar (depending on type)

Maximum Emergency Inlet Pressure Differential Strength

10 bar to 20 bar (depending on type)

Outlet Pressure Range

17 mbar to 3 bar

Maximum Emergency Outlet Pressure (Casing)

4 bar

Maximum Outlet Pressure to avoid Internal Parts Damage

0.34 bar over set-point

Maximum Operating Outlet Pressure

3 bar

Pressure Registration

Internal, external or dual

Temperature Capabilities

According to PED Standards:

-20° to 60 °C

Non-PED:

-30° to 66°C

Approximate Weights

Threaded Body:

Type CSB400: 4 kg

Type CSB403: 9 kg

Type CSB404: 5 kg

Flanged Body:

Add 4 kg to weights listed above

Type VSX4 Slam-Shut Module Specifications

Standard Overpressure Shutoff (OPSO) Set Value:

43 to 3400 mbar

Standard Underpressure Shutoff (UPS0) Set Value:

10 to 1500 mbar

Connections

Slam-Shut Vent: 1/4 NPT

External Sensing Line: 1/4 NPT

Casing Material

Aluminum

Pressure Registration

Internal or external



TYPE CSB400

TYPE CSB404

Features

- Slam-shut
- Ductile Cast Iron and WCC Steel Bodies Available
- Wide Variety of Body Sizes and End Connections
- No Special Tools for Pressure Adjustment and Orifice Removal

Introduction

The CSB600 / CSB700 Series direct-operated, spring-loaded regulators have been engineered to fit a multitude of pressure-reducing applications including commercial and industrial installations.

This flexibility is provided by the numerous body sizes and end connections, outlet pressure settings, as well as the option for internal or external pressure registration.

In addition to application flexibility, the CSB600 / CSB700 offer overpressure protection options, which include an integral slam-shut and also token relief to meet your demands on application requirements.

The CSB600 / CSB700 Series are in conformity with the Pressure Equipment Directive PED 2014/68/UE. The base regulator is classified under Category I, the regulator with slam-shut module is classified under Category IV.

Body Sizes and End Connection Styles

Ductile Cast Iron:

1-1/4 (CSB600 only), 1-1/2 or 2 NPT
 1-1/4 (CSB600 only), 1-1/2 or 2 Rp
 NPS 2 (DN 50) CL125FF, CL150FF
 NPS 2 (DN 50) PN 10/16
 NPS 1-1/4 (DN 32) (CSB600 only)
 NPS 1-1/2 (DN 40) PN 16 Slip-on

Steel:

1-1/4 (CSB600 only), 1-1/2 or 2 NPT
 1-1/4 (CSB600 only), 1-1/2 or 2 Rp
 NPS 2 (DN 50) CL150RF
 NPS 2 (DN 50) PN 10/16

Maximum Operating Inlet Pressure Differential Strength

6 to 16 bar (depending on type)

Maximum Emergency Inlet Pressure Differential Strength

12 to 20bar (depending on type)

Outlet Pressure Range

9 mbar to 4 bar

Maximum Emergency Outlet Pressure (Casing)

5 bar

Maximum Outlet Pressure to avoid Internal Parts Damage

0.34 bar over set-point

Maximum Operating Outlet Pressure

3 bar

Pressure Registration

External

Temperature Capabilities

According to PED Standards:

-20° to 60 °C

Non-PED:

-30° to 66°C

Approximate Weights

Threaded Body:

Type CSB600/620/700/720: 13 kg

Type CSB604/624/704/724: 14 kg

Type CSB654/754: 15 kg

Flanged Body:

Add 5.2 kg to weights listed above

Type VSX8 Slam-Shut Module Specifications

Standard Overpressure Shutoff (OPSO)

Set Value:

40 to 4400 mbar

Standard Underpressure Shutoff (UPS0) Set Value:

8 to 2000 mbar

Connections

Slam-Shut Vent: 1/4 NPT

External Sensing Line: 1/4 NPT

Casing Material

Aluminum

Pressure Registration

Internal or external



Features

- Slam-shut
- Ductile Cast Iron and WCC Steel Bodies Available
- Wide Variety of Body Sizes and End Connections
- No Special Tools for Pressure Adjustment and Orifice Removal

Introduction

The CS800 Series direct-operated, spring-loaded regulators have been engineered to fit a multitude of pressure-reducing applications including commercial and light industrial installations.

This flexibility is provided by the numerous body sizes and end connections, outlet pressure settings, orifice sizes and the option for internal or external pressure registration.

In addition to application flexibility, the CS800 Series offers numerous overpressure protection options which include an Internal Relief, High Capacity Relief and Secondary Seat™ Protection.

The CS800 Series is in conformity with the Pressure Equipment Directive PED 2014/68/UE. The base regulator is classified under Category I, the regulator with slam-shut module is classified under Category IV.

Body Sizes and End Connection Styles

Ductile Cast Iron and Steel:

1-1/4, 1-1/2 or 2 NPT

1-1/4, 1-1/2 or 2 Rp

NPS 2 (DN 50) CL150FF
(ductile cast iron only)

NPS 2 (DN 50) PN 10/16

NPS 2 (DN 50) CL150RF (steel only)

Maximum Operating Inlet Pressure Differential Strength

8.6 bar

Maximum Emergency Inlet Pressure Differential Strength

12.1 bar

Outlet Pressure Range

9 to 690 mbar

Maximum Emergency Outlet Pressure (Casing)

1 bar

Maximum Outlet Pressure to avoid Internal Parts Damage

0.21 bar over set-point

Maximum Operating Outlet Pressure

690 mbar

Pressure Registration

Internal or external

Temperature Capabilities

According to PED Standards:

-20° to 60 °C

Non-PED:

-30° to 66°C

Approximate Weights

Threaded Body:

Type CS800/820: 11 kg

Type CS803/823: 16 kg

Type CS805/825: 12 kg

Type CS806/826: 12 kg

High Pressure Types:

For CS85x add 1 kg to types listed above

Flanged Body:

Add 5 kg to weights listed

Type VSX8 Slam-Shut Module Specifications

Standard Overpressure Shutoff (OPSO) Set Value:

45 to 700 mbar

Standard Underpressure Shutoff (UPS0) Set Value:

11 to 250 mbar

Connections

Slam-Shut Vent: 1/4 NPT

External Sensing Line: 1/4 NPT

Casing Material

Aluminum

Pressure Registration

Internal or external

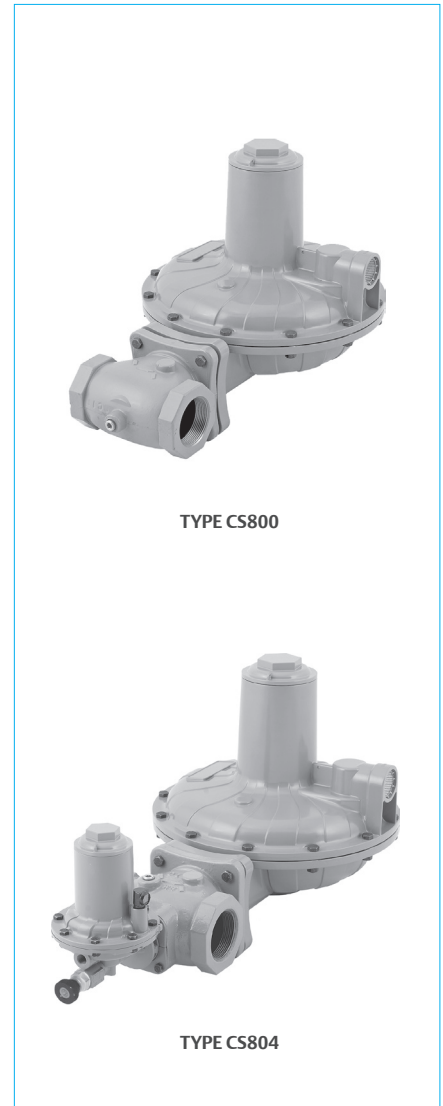

TYPE CS800

TYPE CS804

Features

- Slam-shut
- Ductile Cast Iron and WCC Steel Bodies Available
- Wide Variety of Body Sizes and End Connections
- No Special Tools for Pressure Adjustment and Orifice Removal

Introduction

The R Series spring-loaded regulators provide pressure reducing control for domestic and industrial use, such as burners, furnaces, boilers and other installations requiring proper regulation and quick response time.

The R Series regulators achieve high accuracy and flow rates even with low inlet pressure and inlet pressure variations.

Available Configurations

Types R/70, R/71, R/72, R/72-FS, R/73, R/74, and R/75: Regulator

Types R/70-AP, R/71-AP, R/72-AP, R/72-FS-AP, R/73-AP, R/74-AP, and R/75-AP: High Pressure Regulator

Body Sizes and End Connection Styles

R/70, R/70-AP:

G 3/4" x G 1 1/4" UNI ISO 228/1 right angle (3/4" soft seal x 1 1/4" GAS)

R/71, R/71-AP:

G 3/4" x G 1 1/4" UNI ISO 228/1 right angle (3/4" metallic seal x 1 1/4" GAS)

R/72, R/72-AP:

G 1" UNI ISO 228/1 axial flow (1" GAS)

R/72-FS, R/72-FS-AP:

DN 25 PN 16 - axial flow

R/73, R/73-AP:

G 1 1/4" UNI ISO 228/1 axial flow (1 1/4" GAS)

R/74, R/74-AP:

G 3/4" x G 1 1/4" UNI ISO 228/1 axial flow (3/4" soft seal x 1 1/4" GAS)

R/75, R/75-AP:

G 3/4" x G 1" UNI ISO 228/1 axial flow (3/4" soft seal x 1" GAS)

Temperature Capabilities

Working: -20° to 60 °C

Inlet Pressures

Types R/70, R/71, R/72, R/72-FS, R/73, R/74, and R/75:

Maximum Inlet Pressure: 6 bar

Inlet Pressure Range: 0.1 to 6 bar

Types R/70-AP, R/71-AP, R/72-AP, R/72-FS-AP, R/73-AP, R/74-AP, and R/75-AP:

Maximum Inlet Pressure: 10 bar

Inlet Pressure Range: 0.1 to 10 bar

Outlet Pressure Ranges

Types R/70, R/71, R/72, R/72-FS, R/73, R/74, and R/75: 15 to 70 mbar

Types R/70-AP, R/71-AP, R/72-AP, R/72-FS-AP, R/73-AP, R/74-AP, and R/75-AP: 70 to 300 mbar

Accuracy Class

Up to ±5%

Lock-Up Pressure Class

Up to 10%

Built-In Shutoff Valve

Accuracy Group: ±5%

Response Time: <1 s

Approximate Weights

2 to 4.5 kg

Features

- Two-Stage Regulation
- Built-In Relief Valve (Optional)
- Overpressure and Underpressure Shutoff Valve
- Manual Reset
- Built-in Filter with 0.5 mm Filtering Capacity



TYPE R/70



TYPE R/72



TYPE R/72-FS

Type R/25

Spring-Loaded Pressure Reducing Regulators

TARTARINI™

Introduction

The type R/25 two-stage pressure regulator is designed for use in a wide range of both domestic and industrial applications and can also be mounted in individual domestic gas systems and meters.

Their main features include compact size for space saving, high-quality materials, high regulation accuracy, easy setting and maximum reliability of safety devices.

Their trouble-free operation is ensured in all mounting positions.

The type R/25 regulator is suitable for both outdoor and indoor installations as a highly sensitive safety device ensures the release of gas to the atmosphere in case of overpressure.

Body Sizes and End Connection Style

G 3/4" x G 1 1/4" UNI ISO 228/1 right angle (3/4" soft seal x 1 1/4" GAS)

Maximum Inlet Pressure

6 bar

Inlet Pressure Range

0.1 to 6 bar

Outlet Pressure Range

15 to 50 mbar

Accuracy Class

Up to ±5%

Lock-Up Pressure Class

Up to 10%

Built-in Shutoff Valve

Accuracy Group: ±5%

Response Time: ≤1 s

Orifice Size

7/16"

Temperature Capabilities

Working: -20° to 60 °C

Approximate Weight

1.4 kg

Features

- Two-Stage Regulation
- Built-In Relief Valve (Optional)
- Overpressure and Underpressure Shutoff Valve
- Manual Reset
- Built-in Filter with 0.5 mm Filtering Capacity



Introduction

The type B NV regulator is a direct-operated, spring-loaded regulator providing economical, pressure reducing control in a variety of residential, commercial, and industrial applications.

This compact regulator can be installed in a pressure reducing cabinet or a pressure reducing and metering cabinet above ground or in underground modules.

Available Configurations

B25 NV:

Minimum Inlet Pressure 500 mbar

B40 NV:

Minimum Inlet Pressure 700 mbar

Bb40 NV:

Battery consisting of two B25

BCH30 NV:

Minimum Inlet Pressure 800 mbar

Body Sizes

NPS 3/4 x 1-1/4

End Connection Styles

Inlet:

Sphero-conical or flat joint connection

Outlet:

Flat meter joint connection

Inlet Pressure

Maximum Inlet Pressure: 4 bar

Inlet Pressure Range: 0,5 to 4 bar

Outlet Pressure

Maximum Outlet Pressure: 400 mbar

Pressure Registration

Internal

Temperature Capabilities

-30° to 60° C

Approximate Weight

2 kg

Features

- Integral Slam-Shut Valve
- Compact Design
- Internal Relief
- Two Stages of Reduction for Constant Outlet Pressures
- Inlet Strainer



TYPE B25 NV

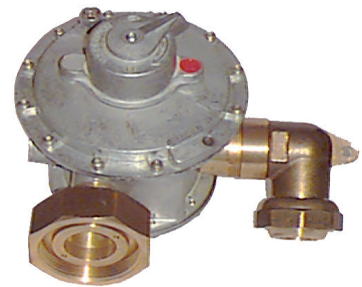

TYPE Bb40 NV



TYPE BCH NV

Introduction

The BM5 Series slam-shut valve is an automatic shutoff appliance suitable for installation as a safety device in regulating stations and gas distribution piping.

The slam-shut valve is designed to shutoff the flow of gas in the event of the pressure rising above or falling below the predefined levels.

The valve is a sleeve-type, therefore, does not require any external by-pass to facilitate the opening of the valve. The valve can only be reset manually.

The BM5 Series is in conformity with the Pressure Equipment Directive PED 2014/68/UE and is classified under Category IV.

Body Sizes

DN 25, 40, 50, 65, 80, 100, and 150
(NPS 1, 1-1/2, 2, 2-1/2, 3, 4, and 6)

End Connection Styles

PN 16, 25 / CL150, CL300, and CL600

Allowable Pressure

Up to 100 bar

Underpressure Set Range

0.01 to 80 bar

Overpressure Set Range

0.03 to 80 bar

Accuracy Group

Up to ±1%

Response Time

< 1 s

Temperature Capabilities

Standard Version:

Working: -10° to 60 °C

Low Temperature Version:

Working: -20° to 60 °C

Approximate Weights

15 to 280 kg

Features

- Axial Flow
- Sleeve Valve
- Protected Seal Pad
- Push-Button Manual Emergency Release
- Manual Reset by Rotating the Reset Shaft
- Low Temperature Construction Available

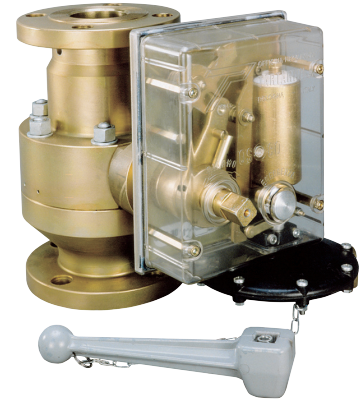

TYPE BM5 WITH OS/80X

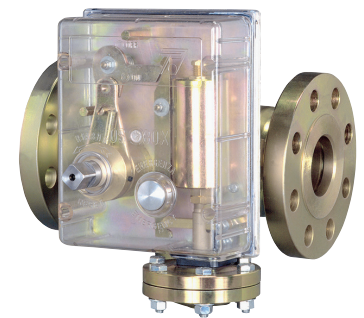

TYPE BM5 WITH OS/80X-APA-D

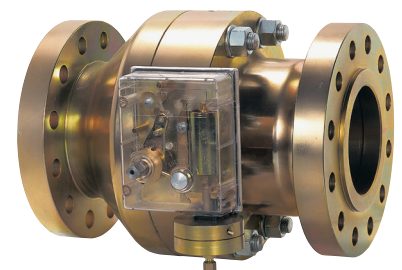

TYPE BM5 WITH OS/80X-APA

Introduction

The BM6X Series axial flow slam-shut valve is an automatic shutoff appliance suitable for installation as a safety device in pressure reducing stations and on gas transfer and distribution lines.

BM6X Series slam-shut valves are "wafer" type with an off-center butterfly disk that is mounted eccentrically.

The reduced face-to-face dimension, typical of "wafer" valves, facilitates installation even in existing stations that are not equipped with shutoff devices.

The slam-shut valve is designed to shutoff the flow of gas in the event of the pressure rising above or falling below the predefined levels.

The gas flow causes the slam-shut valve to shutdown and can only be reset manually.

BM6X Series slam-shut valves use gas from the gas line for operation and therefore does not require outside sources to operate.

BM6X Series is in conformity with the Pressure Equipment Directive PED 2014/68/UE and is classified under Category IV.

Body Sizes

DN 80, 100, 150, 200, 250, and 300 (NPS 3, 4, 6, 8, 10, and 12)

End Connection Styles

CL150, CL300, and CL600

Allowable Pressure

Up to 100 bar

Underpressure Set Range

0.01 to 80 bar

Overpressure Set Range

0.03 to 80 bar

Accuracy Group

Up to ±1%

Response Time

< 1 s

Temperature Capabilities

Standard Version:

Working: -10° to 60 °C

Low Temperature Version:

Working: -20° to 60 °C

Approximate Weights

10 to 125 kg

Features

- Axial Flow
- "Wafer" Type Valve
- Off-Center Butterfly Disk
- Pressure Control at One or More Points of the System
- Activation Due to Pressure Increase or Decrease
- Emergency Slam-Shut Push-Button
- Button By-pass with Automatic Return
- Manual Reset by the Sole Rotation of the Reset Shaft
- Easy Maintenance
- Sour Gas Construction Available



TYPE BM6X WITH OS/80X-APA-D



TYPE BM6X WITH OS/84

Introduction

The type OSE slam-shut valve is used to totally and rapidly cut the gas flow when the pipeline pressure exceeds the set pressure or when the pipeline pressure drops below the set pressure.

The type OSE consists of a valve, a water-tight mechanism box, and a manometric device.

A double stage mechanism detects any pressure variances.

Detection is the first stage and the mechanism will only trip when the pipeline pressure reaches the set pressure.

The second stage is the power stage; once tripped, the closing spring causes the valve plug to slam shut and remain closed until the valve is manually reset.

The OSE is in conformity with the Pressure Equipment Directive PED 2014/68/UE and is classified under Category IV.

Available Configurations

Type OSE:

Slam-Shut Valve DN 25 to DN 150 (NPS 1 to 6) with Internal By-pass

Type OSE LS:

Slam-Shut Valve DN 200 and DN 250 (NPS 8 and 10) with External By-pass Manually Operated

Body Sizes

DN 25, 50, 80, 100, 150, 200, and 250 (NPS 1, 2, 3, 4, 6, 8, and 10)

End Connection Styles

PN 100B2, 50 B1, 20 B
CL150, CL300, CL600

Pressure Ratings

Maximum Inlet Pressure: 100 bar
Maximum Set Pressure or Maximum Body Rating: 100 bar
Minimum Set Pressure: 10 mbar
Maximum Shutoff Pressure Differential: 100 bar

Pressure Registration

External

Pressure Sensing and Vent Connection

1/4" NPT

Manometric Sensing Device Specifications

Spring Ranges: 10 mbar to 72.9 bar
Max Sensing Inlet Pressure: 72.9 bar
Set-point Tolerance: 0.004 bar to 12 bar
Maximum Difference between Overpressure and Underpressure: 33 bar

Temperature Capabilities

-30° to 71°C

Options

- Explosion-proof switch
- Non-explosion proof limit switch
- Solenoid
- Additional manometric device for extra pressure sensing

Approximate Weight

14 to 577 kg

Features

- Overpressure and Underpressure Protection
- Two-Stage Tripping Mechanism
- High Accuracy
- Easy In-Line Maintenance
- Water-Tight
- Manually Rearmed

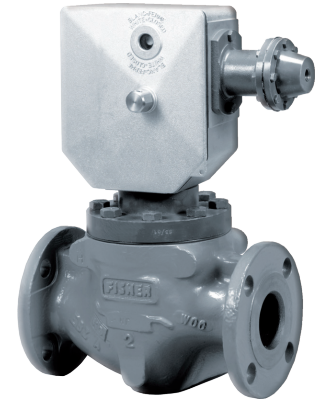

TYPE OSE

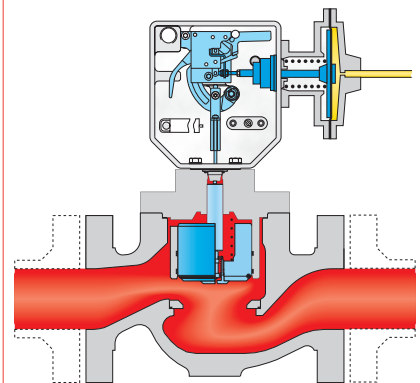

TYPE OSE OPERATIONAL SCHEMATIC

Introduction

The type VS100 slam-shut is designed to shut off the flow of gas to the downstream system in the event of outlet pressure rising above or falling below the predefined levels.

The type VS100 consists of a body with a removable orifice, enclosed by a bonnet, and a type VSX4 slam-shut device.

The type VS100 is in conformity with the Pressure Equipment Directive PED 2014/68/UE and is classified under Category IV.

Available Configurations

Types VS111 and VS112:

19 mm / 0.75" orifice size medium capacity application

Body Sizes and End Connection Styles

Medium Capacity Body (MC):

- Rp 1, 1-1/4, 1-1/2
- 1, 1-1/4, 1-1/2 NPT
- Rp 1 x 2-1/4 GAZ
- DN 40 PN 16 slip-on

Maximum Inlet Pressure

Differential Strength (DS): 16 bar
Integral Strength (IS): 6 bar

Maximum Allowable Pressure

20,0 bar

Temperature Capabilities

According to PED Standards:

-20° to 60 °C

Non-PED:

-30° to 66°C

Approximate Weights

3,5 to 3,7 kg

Features

- Quick Response Time
- Ductile Iron and Steel Body Construction

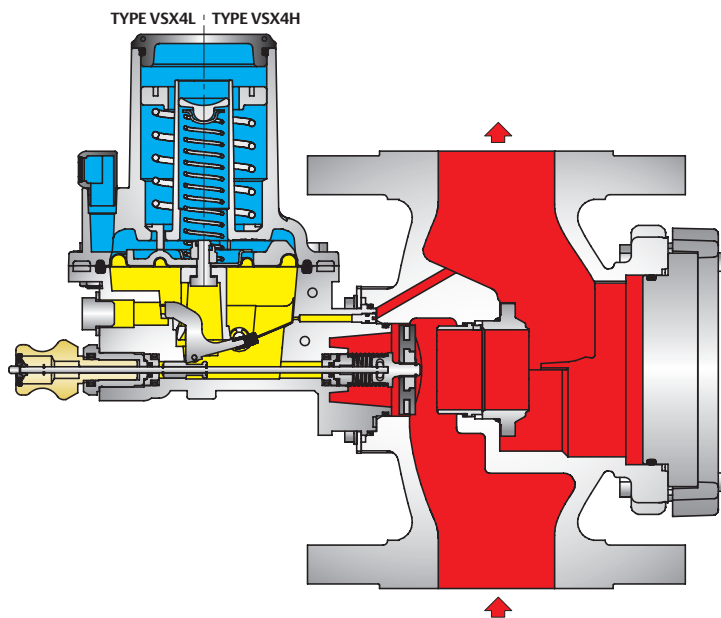

LEGEND

- INLET PRESSURE
- OUTLET PRESSURE
- ATMOSPHERIC PRESSURE

Introduction

Servo-controlled relief valves are used in natural gas transmission applications.

They assure accurate setting, perfect closing, and high exhaust flow rate.

VS-FL and VS-FL-FR Series are in conformity with the Pressure Equipment Directive PED 2014/68/UE and are classified under Category IV.

Available Configurations

VS-FL Series

Type VS-FL-BP:

Low and Medium Pressure Applications with Pilot Type PRX/182

Type VS-FL:

Medium and High Pressure Applications with Pilot Types PRX/182 or PRX-AP/182

VS-FL-FR Series

Type VS-FL-FR-BP:

Low and Medium Pressure Applications with Pilot Types PRX/182

Type VS-FL-FR-HP:

Medium and High Pressure Applications with Pilot Types PRX/182, PRX-AP/182

All VS-FL and VS-FL-FR type relief valves are available with or without:

Type SR: Silencer

Body Sizes

VS-FL Series:

DN 25, 40, 50, 65, 80, 100, 150, 200, and 250
(NPS 1, 1-1/2, 2, 2-1/2, 3, 4, 6, 8, and 10)

VS-FL-FR Series:

DN 25, 50, 80, 100, 150, 200, and 250
(NPS 1, 2, 3, 4, 6, 8, and 10)

End Connection Styles

PN 16 / CL150, CL300, and CL600

Inlet Pressure Range

Flange Rating PN 16 / CL150:

Allowable Pressure: Up to 20 bar
Inlet Pressure Range: 0.2 to 20 bar

Flange Rating CL300, CL600:

Allowable Pressure: Up to 100 bar
Inlet Pressure Range: 1 to 100 bar

Set Range

Flange Rating PN 16 / CL150

0.5 to 19.3 bar

Flange Rating CL300, CL600

1 to 80 bar

Temperature Capabilities

VS-FL Series

Standard Version:

Working: -10° to 60 °C

Low Temperature Version:

Working: -20° to 60 °C

VS-FL-FR Series

Working: -20° to 60 °C

Approximate Weights (Including Pilot)

24 to 1190 kg

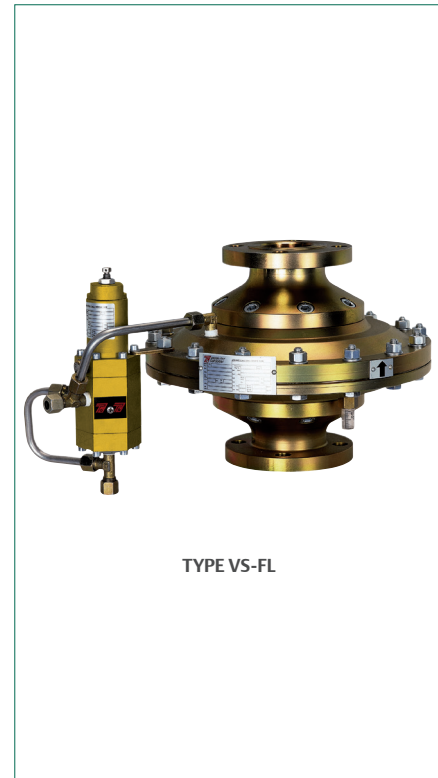

Features

- Ease of Installation
- Ease of Maintenance
- High Operation Accuracy

Introduction

The V series automatic spring-loaded relief valves are designed to keep line pressure below preset values.

They are mounted downstream of regulators and perform the specific function of releasing small amounts of gas in the event of the regulator not closing properly.

The V Series is in conformity with the Pressure Equipment Directive PED 2014/68/UE and is classified under Category I maximum.

Available Configurations

Types V/50 and V/60:

Very Low Pressure Applications

Types V/51 and V/61:

Low Pressure Applications

Types V/52 and V/62:

Medium Pressure Applications

Type V/20-2:

High Pressure Applications

Body Sizes and End Connection Styles

V/50 Series:

1 x 1-1/2" BSP Threaded

V/60 Series:

1-1/2 x 2" BSP Threaded

Type V/20-2:

1" NPT Threaded

Inlet Pressure

V/50 Series: 4 bar

V/60 Series: 2.5 bar

Type V/20-2: 100 bar

Set Range

V/50 and V/60 Series: 0.025 to 2 bar

Type V/20-2: 1.5 to 40 bar

Orifice Size

V/50 Series: 1 1/4"

V/60 Series: 1 1/2"

Type V/20-2: 1"

Temperature Capabilities

Standard Version:

Working: -10° to 60 °C

Low Temperature Version:

Working: -20° to 60 °C

Approximate Weight

V/50 Series: 1.3 kg

V/60 Series: 1.9 kg

Type V/20-2: 1.6 kg

Features

- Easy Installation and Maintenance
- Release Capacity
- Accuracy



TYPE V/50



TYPE V/60

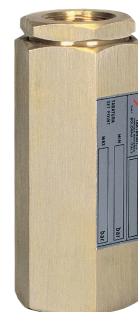

TYPE V/20-2

Introduction

The type VFA butterfly valves are "wafer" flangeless type and typically used in gas reducing stations for an on-off service.

The VFA butterfly valves, due to their particular construction features, have very low pressure losses and excellent seal.

This series of butterfly valves is designed basically for natural gas transmission or distribution grids, and for commercial and industrial applications.

Their reduced overall dimensions allow simple installation and easy maintenance.

The VFA Series are in conformity with the Pressure Equipment Directive PED 2014/68/UE and are classified under Category III maximum.

Available Configurations

VFA:

Lever operated

VFA-MR:

Gear operated

VFA-MRO:

Gear operated for use with absorbing odorizing systems

Body Sizes

DN 50, 65, 80, 100, 125, 150, 200, and 250
(NPS 2, 2 1/2, 3, 4, 5, 6, 8, and 10)

End Connection Styles

PN 16, CL150

Inlet Pressure Range

Allowable Pressure: Up to 19 bar

Temperature Capabilities

Working: -10° to 60 °C

Approximate Weight

11.5 to 103 kg

Features

- **Tight Shutoff**
- **Compact Design**
- **Easy Installation in All Positions**
- **Easy Maintenance**
- **Very Low Pressure Loss**

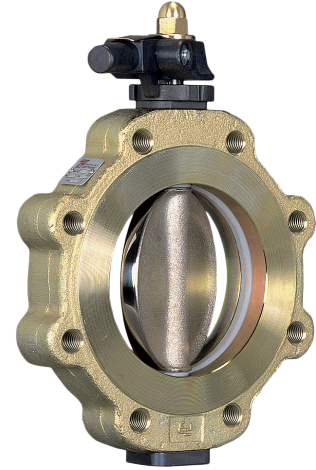

TYPE VFA

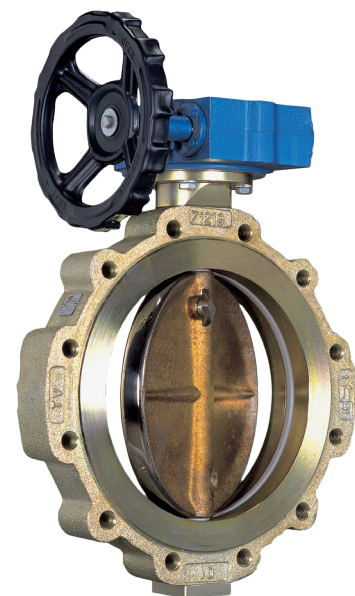

TYPE VFA-MR

Introduction

The type CNF, CN, CF, and SV heat exchangers are sized and designed to meet a large range of system requirements, and include all connections for all accessories required.

In the gas pressure reduction process according to the “Joule-Thomson” effect, temperature drops considerably (approximately 0.5° C per reduction bar).

This fall in gas temperature can damage the equipment due to the formation of dangerous ice crystals produced by water vapor in the gas.

Particularly in first stage stations, high pressure changes are usually involved, therefore, the gas must be heated before pressure is reduced.

It is recommended that, after reduction, gas temperature should not be below 5°C.

One of the best established methods of heating gas in reduction stations is to use heat exchangers employing hot water or steam as their thermal carrier fluid.

CNF, CN, CF, and SV Series are in conformity with the Pressure Equipment Directive PED 2014/68/UE and are classified under Category IV maximum.

Available Configurations

CNF, CN, and CF Series:

Water as Thermal Carrier Fluid

SV Series:

Steam as Thermal Carrier Fluid

End Connection Styles

Gas Side: CL300, CL600

Water or Steam Side: PN 6

Applications

- Pre-heating of natural gas in first reception and pressure reduction stations, and for all gas heating requirements
- Non-Corrosive Gases

Maximum Water Temperature

CNF, CN, and CF Series: 90°C

Maximum Steam Temperature

SV Series: 120°C

Installation and Assembly

- Heat Exchangers designed for installation with vertical tube bundle
- Different tube bundle configurations available upon request

Approximate Weights

90 to 1350 kg

Features

- Tube Bundle Heat Exchangers using U-Tubes (BEU)
- Tube Bundle with Inspection Facility
- Gas in Tubes Section, Thermal Carrier Fluid in Shell Section
- Axial Connections in Gas Section
- Designed for Automatic Air Escape Installation
- Designed for Relief Valve Installation



TYPE CF

Introduction

Filters are intended to screen out larger pieces of foreign particles, often present in the gases or particularly during the initial stages of operation of newly laid pipes, minimizing damage to valves, pressure regulators, meters and other equipment used in regulating and metering stations.

The FA and FAG Series filters can be used with natural and manufactured gases, air, propane and other gases so long as they do not contain high percentages of benzol.

They have threaded connections for the mounting of the drain cock (supplied on request) and other accessories.

Filters for customers' specific requirements can be made upon request only.

The FA and FAG Series are in conformity with the Pressure Equipment Directive PED 2014/68/UE and are classified under Category IV maximum.

Available Configurations

FA Series: High pressure filters

FAG Series: Medium and low pressure filters

Type FG/07: Medium and low pressure filters with threaded connections

End Connection Styles

FA Series Axial Flow Connections

CL150, CL300, and CL600
DN 50, 65, 80, 100, 150, 200, 250, 300, 350 and 400
(NPS 2, 2-1/2, 3, 4, 6, 8, 10, 12, 14, and 16)

FAG Series 90° Flow Connections

PN 16 / CL150

FAG-A Series Axial Flow Connections

PN 16 / CL150
DN 50, 65, 80, 100, 125, 150, 200, 250, and 300
(NPS 2, 2-1/2, 3, 4, 5, 6, 8, 10, and 12)

Type FG/07 Axial Flow Connections

1" Gas

Inlet Pressure

FA Series:

Maximum Allowable Pressure: Up to 90 bar

FAG and FAG-A Series:

Maximum Allowable Pressure: Up to 19 bar

FG/07 Type:

Maximum Allowable Pressure: 16 bar

Filtering Capabilities

FA Series:

Filtering Surface: 0.25 to 8.4 m²

Filtering Degree: 5 µm

FAG and FAG-A Series:

Filtering Surface: 0.06 to 4.2 m²

Filtering Degree: 5 µm

Type FG/07:

Filtering Surface: 0.09 m²

Filtering Degree: 5 µm

Temperature Capabilities

FA Series

Standard Version:

Working: -10° to 100° C

Low Temperature Version:

Working: -20° to 100° C

FAG and FAG-A Series

Standard Version:

Working: -10° to 60° C

Low Temperature Version:

Working: -20° to 60° C

Type FG/07:

Working: -10° to 60° C

Approximate Weights

2,1 a 1205 kg

Features

- Versatility
- Wide Range of Applications
- Easy Maintenance
- Axial and Right-Angle Connections
- Quick Opening Version Available on Request

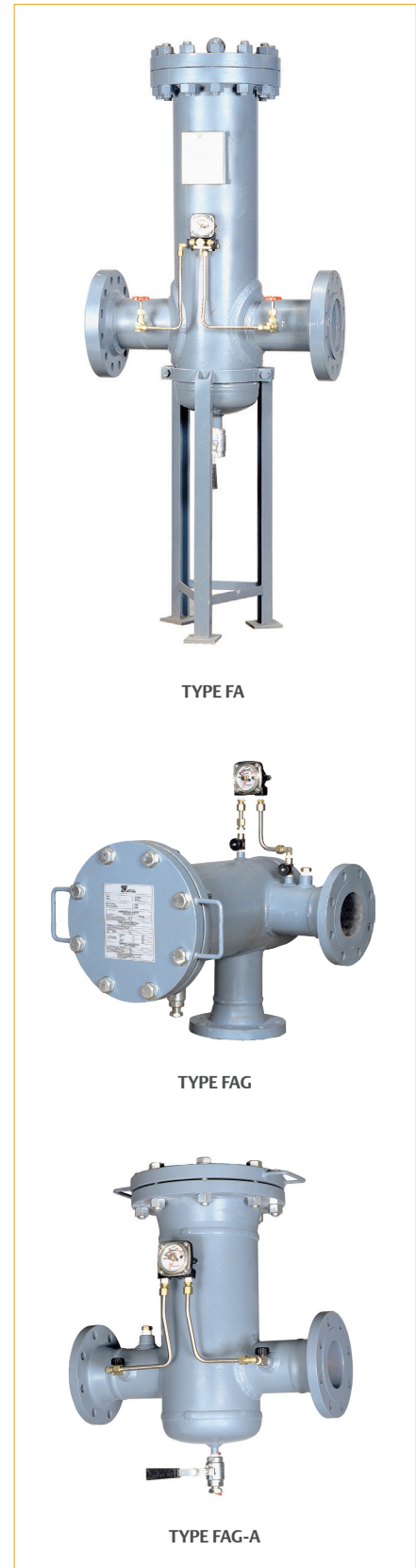

TYPE FA

TYPE FAG

TYPE FAG-A

Types BLE and BLX

Throttle Valve

FISHER™

Introduction

The types BLE and BLX throttle valves function as a by-pass on transmission stations reducing pressure.

The type BLX version is equipped with a type OS2 release relay to cut off the gas flow in case of outlet over pressure.

The types BLE and BLX are in conformity with the Pressure Equipment Directive PED 2014/68/UE and are classified under Category IV.

Available Configurations

Type BLE:

Throttle Valve

Type BLX:

Throttle Valve with Shutoff Valve

Body Sizes

DN 25, 50, 80, 100 (NPS 1, 2, 3 and 4)

End Connection Styles

PN 16 B, PN 25 B, and PN 40 B
CL 600B, CL 300B, CL 150B

Maximum Operating Pressure

100 bar

Temperature Capabilities

Working: -30° to 71°C

Approximate Weights

Type BLE:

DN 25 (NPS 1): 12 to 14 kg
DN 50 (NPS 2): 22.5 to 26.5 kg
DN 80 (NPS 3): 43 to 51 kg
DN 100 (NPS 4): 80 to 96 kg

Type BLX:

DN 25 (NPS 1): 20 to 22 kg
DN 50 (NPS 2): 36 to 40 kg
DN 80 (NPS 3): 57 to 65 kg
DN 100 (NPS 4): 115 to 131 kg

Features

- Robust Design
- High Precision
- Progressive Opening

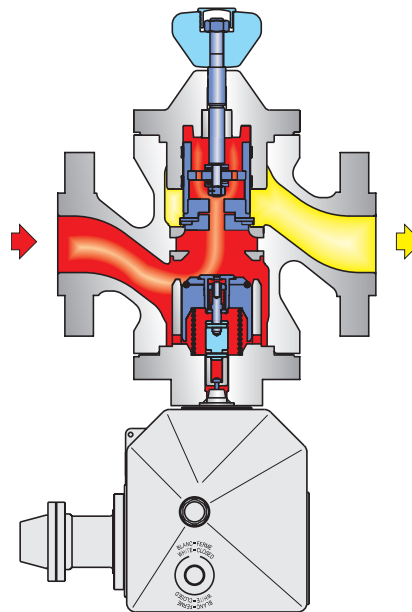
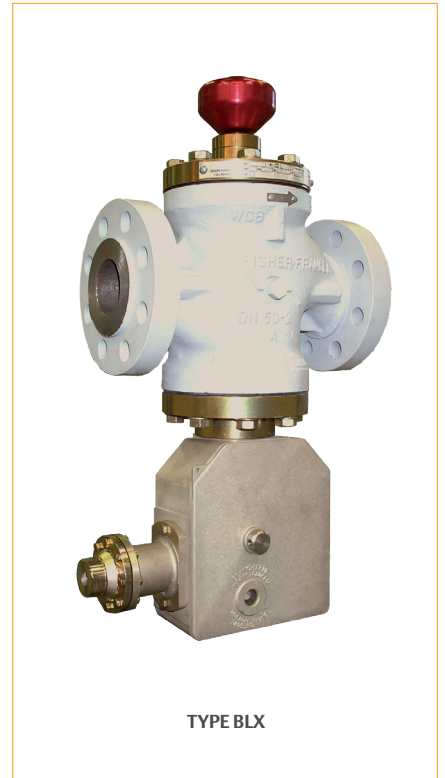

TYPE BLX - OPERATIONAL SCHEMATIC

LEGEND

■ INLET PRESSURE

■ OUTLET PRESSURE

Introduction

The OL Series is an absorption-type odorizing system employed in small and large-sized stations.

They are used as stand-by and emergency systems in all injection-type odorizing installations.

Differential pressure is necessary to achieve proper operation.

The OL Series is in conformity with the Pressure Equipment Directive PED 2014/68/UE and is classified under Category IV maximum.

Available Configurations

Tank and Valves:

- Carbon Steel
- Stainless Steel

Level Indicator:

- Vertical
- Diagonal
- Magnetic for Remote Control

- OL-25: Volume 25 l
- OL-50: Volume 50 l
- OL-100: Volume 100 l
- OL-150: Volume 150 l
- OL-200: Volume 200 l
- OL-250: Volume 250 l
- OL-300: Volume 300 l
- OL-1000: Volume 1000 l

End Connection Styles

PN 6, PN 16 / CL150, CL600

Maximum Allowable Pressure
Up to 90 bar

Temperature Capabilities

Working: -10° to 60 °C

Features

- Direct Reading Level Gauge
- Regulating, Shutoff and Filling Valves

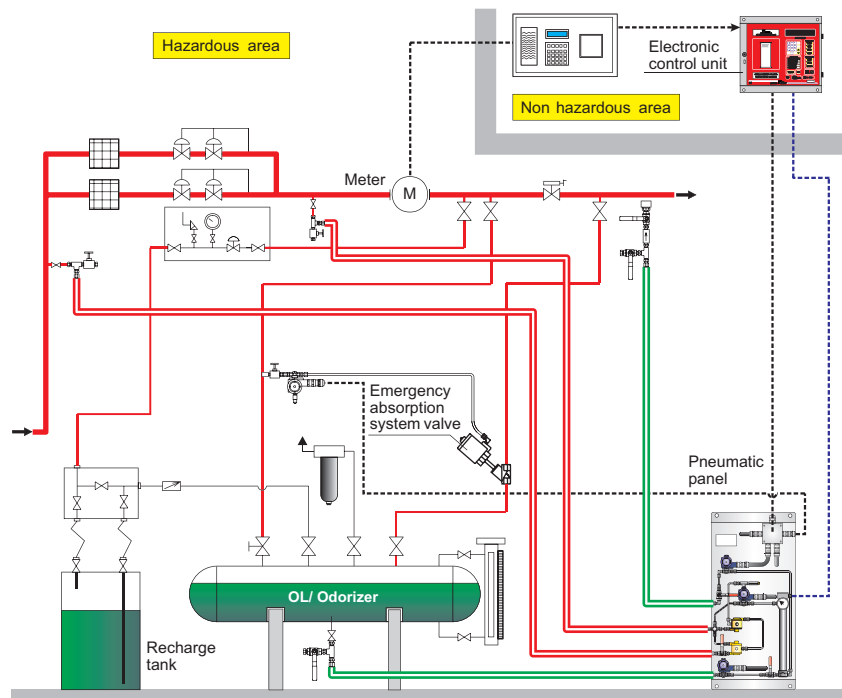

EXAMPLE OF TYPE OL/ INSTALLATION IN A COMPLETE ODORIZING SYSTEM WITH DOSAODOR-D

Introduction

The type Dosaodor-D is a computerized odorant injection system for natural gas that uses patented solenoid injector technology eliminating the need for plunger pumps.

The solenoid injectors permit odorant injection accuracy to be maintained over the entire range of the system, approaching infinite turn down.

Dosaodor-D is in conformity with the Pressure Equipment Directive PED 2014/68/UE and is classified under Category II.

Available Configurations

Pneumatic Panel

Type B1:

Single injector version with one solenoid valve for injection management

Type B2:

Dual injector version with two solenoid valves for injection management

Remote Control Software

DOSALINK

Pneumatic Panel Specifications

Material:

20/10 mm stainless steel plate

Installation:

Wall mounted

Weight:

25 - 45 kg (based on configuration type)

Overpressure Stainless Steel Relief Valve with the Following Rating Options:

14 bar - 38 bar - 60 bar

Electrical Protection:

Explosion proof and intrinsically safe

Material Electrical Protection:

Available for European and North American standards

Mechanical Connections

Odorant Inlet and Discharge:

DN 1/4" double ferrule fitting for DN 6x1 pipe

Gas Inlet and Discharge:

DN 1/4" single ferrule fitting for DN 8x1 pipe

Maximum Working Pressure:

Supply: 100 bar

Injection: 14, 38, 60 bar

Odorant Flow Rate:

0.5 – 14 l/h

Temperature Capabilities:

Working: -10° to 60 °C

Electronic Control Unit Specifications

Construction Material:

10/10 mm steel plate

Finish:

RAL 7032 grey epoxy powder coat

Door:

Lockable with window

Installation:

Wall mounted

Weight:

22 kg (medium complexity configuration)

Power Supply Options:

12Vdc+/-15%

115 Vac 60Hz

230 Vac 50Hz

Electromagnetic Interference:

Consistent with 89/336/CE standard

Humidity:

10% – 90% non-condensing

Electrical Protection:

Explosion proof/Intrinsically safe



PNEUMATIC PANEL

ELECTRONIC CONTROL UNIT

Features

- Consistent Odorization Proportional to Entire Range of Gas Flow Rate
- Significantly Reduced Maintenance
- Variety of Redundancy Options for Odorization
- User-Friendly Configuration Software
- Automatic Calibration During Operation
- Standard and Scalable Hardware Platform

Introduction

The Dosaodor DO200 is a Smart odorant system for natural gas, that injects odorant proportional to the flow rate of the gas in transit.

The Dosaodor DO200 is completely configurable and can interface with remote monitor and control system. The system can be configured to use redundant injectors and/or emergency absorption system.

Dosaodor DO200 is in conformity with the Pressure Equipment Directive PED 2014/68/UE and is classified under Category II.

Injection Panel Specifications

Material:

Stainless Steel

Liquid odorants:

THT/Mercaptans

Installation:

Wall or floor (optional)

Maximum Feeding Pressure:

100 barg

Working Temperature:

-10 +60 °C

Sampling Cylinder:

Optional, refer to Emerson offices for proper application

Weight:

30 kg

Classification:

Atex Certification Ex e (Solenoid Valve and Junction Box),
Ex D Flame proof (DP level transmitter)

Control Panel Specifications

Cabinet Material:

Resin IP55

Installation:

Wall mounted

Power Requirements:

100-240 Vac 50-60 Hz o 24 Vdc

Consumption:

120 W @ 24 Vdc

Electromagnetic Interferences:

Compliant to 89/336/CE

Operating Temperature:

0 +40 °C

Humidity:

10% - 90% not condensate

Installation Site:

Safe Area (not classified)

Display:

7" Touchscreen

Remote Communication:

Gateway 3G - 4G (optional)

Communication Protocol:

MODBUS RTU/TCP

Remote Management Software:

Integrated web server



Features

- Operational safety
- Extreme reliability
- Easier maintenance
- Ease of use
- Results certainty

Introduction

Managing entire Natural Gas grids includes diversifying gas sources and expanding the customer base while balancing both ends to ensure reliable, safe and efficient operations.

To satisfy this, transmission and distribution companies design redundant safety layers and oversized grids while operating them at the highest pressure levels which increases gas leaks.

Frequent on-site interventions are necessary to perform regular checks and set up pressure reducing equipment to accommodate seasonal service condition changes which is a challenge as valuable field engineering resources are scarce.

This impacts gas utilities' financial bottom line while exposing them to environmental fines.

Remotely and automatically controlling entire operations, from pressure reducing equipment up to a gas transmission and distribution network, permits safer and more productive management of operations while reducing costs.

Our remote control technology can be used in all types of our integrated solutions:

Skids

Skids are prefabricated pressure reducing stations designed to the customer's specifications, then built to order including a range of products from our brands, Tartarini™ and Fisher™, such as regulators, manual isolation valves, and piping.

Skids reduce overall costs and include components such as filters, slam-shuts, heaters, and meters.

Emerson has many years of experience designing and assembling regulating and metering stations. We have skid manufacturing sites in China, India, Dubai, UK and Italy to respond to local customer specifications in each World area.

Our array of standard and customized installations incorporate the latest in engineering technology for transmission, distribution, and utilization applications.

Emerson pressure-reducing stations can be developed for open air, underground or cabinet/building-protected applications.

Our experience and professionalism acquired over the years enables us to offer our customers a complete product and service offering including:

- Quotations
- Feasibility Studies
- Site Surveying
- Project Management
- Construction
- Revamping
- Commissioning/Start-up
- TurnKey Projects
- Training (field/site)
- Lifecycle Services

City Gate / Transmission / Distribution Stations

High-pressure transmission pipelines move the gas from the production company's cleaning plants to gas distribution companies.

Power Plant / Fuel Gas Stations

From the biggest electricity generation sites to the most recent cogeneration technologies, Emerson provides unrivaled solutions for all your energy needs.

Odorization Solutions

The best odorant injection technology that brings the highest safety level in the natural gas distribution grid, Emerson odorization solutions can be engineered to meet customer needs.

Commercial / Industrial Service

Worldwide, natural gas is used for commercial and industrial applications. Commercial applications, such as grocery stores and office buildings, use natural gas for heating.

Customized Stations

Emerson brings together technology and engineering providing a wide range of manufacturing and processing solutions for all natural gas applications.



TYPICAL EXAMPLE OF A SMART SKID

Introduction

The RAF is a system patented by Emerson and allows automatic management, with programmed logic and without operator intervention, of the different sections that make up a natural gas pressure reduction plant.

Incorporating a control unit, customizable touch screen interface and smart software, it is highly scalable with the ability to automatically manage individual equipment, a complete pressure reducing and metering station and an entire grid.

To facilitate this, it includes an extensive range of communication modes to allow all kinds of local and remote connections. The programmable logic developed by industry experts offers a variety of features which simplify, optimize and secure the management of any natural gas installation.

The RAF System is mainly composed of:

- A control panel, inside which there is a PLC where the operation logic resides and which collects the signals coming from the field
- An electropneumatic actuator acting on the loading pressure of the active regulator pilot, comprising:
 - A solenoid valve for loading the loading pressure
 - A solenoid valve for unloading the loading pressure
 - A pressure transmitter for measuring the loading pressure value
- A pressure transmitter to provide the feedback of the downstream pressure of the station.

The number of RAF system actuators is directly proportional to the pressure reducing line under control. The system acts by means of a closed control loop, which automatically manages the output pressure value of the station according to a set point.

The RAF is in conformity with the Pressure Equipment Directive PED 2014/68/UE and is classified under Category II.

Control Panel Specifications

Cabinet Material:

Resin IP55

Installation:

Wall mounted

Power Requirements:

100-240 Vac 50-60 Hz o 24 Vdc

Consumption:

120 W @ 24 Vdc

Electromagnetic Interferences:

Compliant to 89/336/CE

Operating Temperature:

-10 +40 °C

Humidity:

10% - 90% not condensate

Installation Site:

Safe Area (not classified)

Display:

7" Touchscreen

Remote Communication:

Gateway 3G - 4G (optional)

Communication Protocol:

MODBUS RTU/TCP

Remote control software

Integrated HMI web server

Integrated PLC web server



SOLENOID VALVES

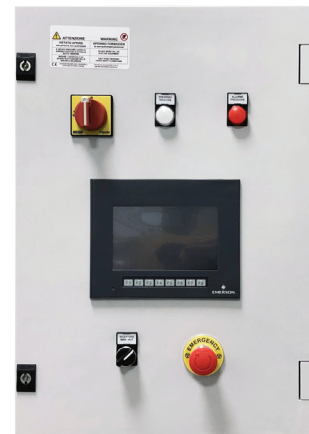

CONTROL PANEL

Features

- Regulation output pressure value to a preset value or dynamically
- Limitation of the instantaneous flow rate value to a preset value or dynamically
- Split distribution of the flow rate on several control lines
- Remote closure of the pressure lines in manual or automatic mode
- Remote diagnostics

Introduction

The V/31-2-E pneumatic switch series are installed in the pressure reducing stations equipped with pilot operated regulators for splitting the natural gas flow rate among the multiple streams.

It uses only the pneumatic force provided by the natural gas, without requiring electric power.

Available Configurations

TYPES V/31-2-E, V/31-2-AP-E and V/31-2-AP-EM:

Pneumatic switches with adjustable set-point

V/31-2-AP-EF and V/31-2-AP-EMF:

Pneumatic switches with fixed set-point

End Connection Styles

1/4" NPT female threaded

Pressure Ratings

Type V/31-2-E:

Allowable Pressure: 19 bar

Types V/31-2-AP-E, V/31-2-AP-EM, V/31-2-AP-EF and V/31-2-AP-EMF:

Allowable Pressure: 100 bar

Temperature Capabilities

Standard Version:

Working: -10° to 60 °C

Low Temperature Version:

Working: -20° to 60 °C

Features

- **Station Increased Total Flow Rate**
- **Uses Only the Pneumatic Force Provided by the Natural Gas, Without Requiring Electric Power**
- **Reduced Station Noise Level, due to Lower Flow-Rate Through Each Stream**
- **Easy Retrofit in the Existing Station**
- **Does Not Impact the Safety System of the Station. The V/31-2-AP-E Pneumatic Switch Series, has a Fail Close Reaction. In Case of its Failure, the Station Will Work According to its Original Configuration**

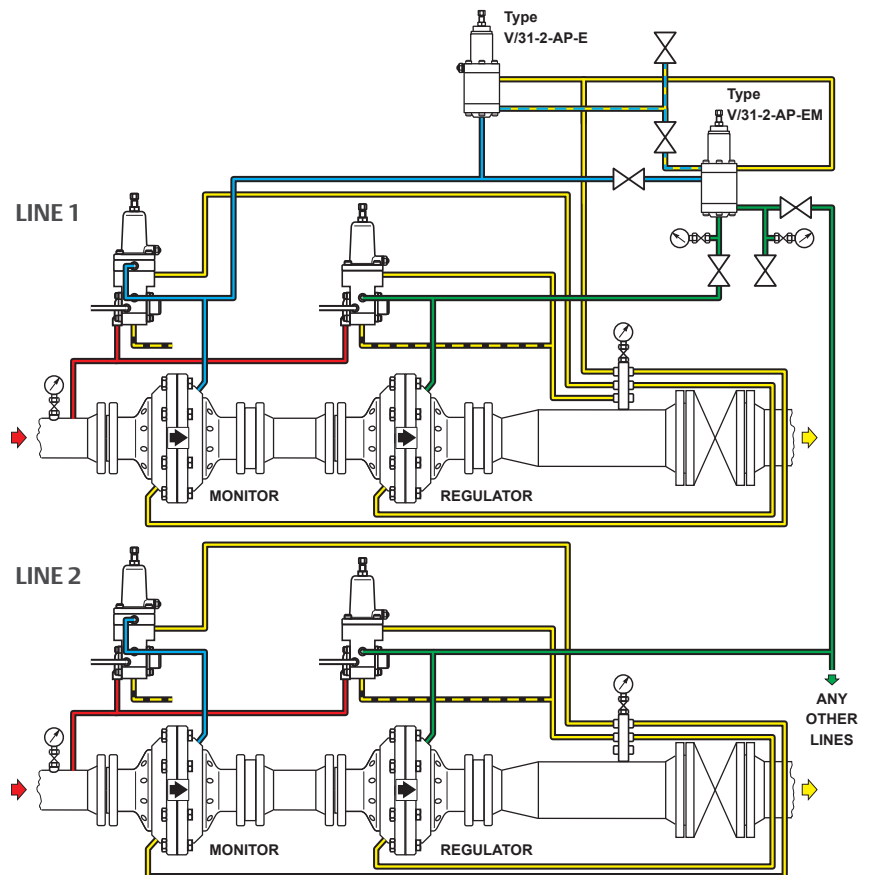

TYPE V/31-2-AP-EM SWITCH FOR FLOW PARTITION SYSTEM CONNECTION/INSTALLATION SCHEMATIC

Emerson After-Sales Services

Emerson provides a complete After-Sales Service for all their products including:

- Installation, start-up and commissioning operations
- Scheduled technical and on-call assistance
- Emergency call-out service equipped with back-up regulating units to guarantee the continuity of operation
- Upgrade and revamp of existing equipment
- Under warranty claims
- Certification for all service interventions according to national and international standards, guaranteeing the quality of operations carried out by the Emerson After-Sales Technicians
- A complete range of spare parts and kits stored in our fully automated warehouse to guarantee fast deliveries
- An educational service offering a complete range of training programs for customers of all levels developed and taught by experienced engineers

Emerson Educational Services

With nearly 30 years of training experience, the Emerson Educational Service is committed to providing quality training to over 4,800 individuals, when and where you need it.

Factory Training:

We host factory training courses in our fully equipped training room equipped with regulation stations, compressed air and multimedia tools.

On-Site, Local Training:

We develop on-site local training courses providing tailor training to meet your specific needs.

Here are two examples of the type of training courses we offer our customers:

Natural Gas Products Service and Maintenance Training Course - Level I

This 3-day course is designed primarily for technicians, engineers and other persons involved in the maintenance,

installation and operation of pressure reduction products and applications.

This course provides a basic understanding of the theories of operation, installation, maintenance and troubleshooting.

Natural Gas Products Service and Maintenance Training Course - Level II

This 3-day course is designed primarily for technicians, administration personnel and other persons with solid knowledge and experience of pressure reduction products and applications.

This course focuses on theoretical knowledge and advanced operational procedures for commissioning, calibration and maintenance.

Pressure University

This program was created specifically by Emerson Tartarini, to allow customers to access courses on all our equipment and solutions, in person and even remotely in a live interaction.

Participants will be in direct contact with the instructors, with the ability to interact remotely in real time as if they were in attendance, thus maximizing the training experience.

Remote training sessions will also be recorded and available upon request.

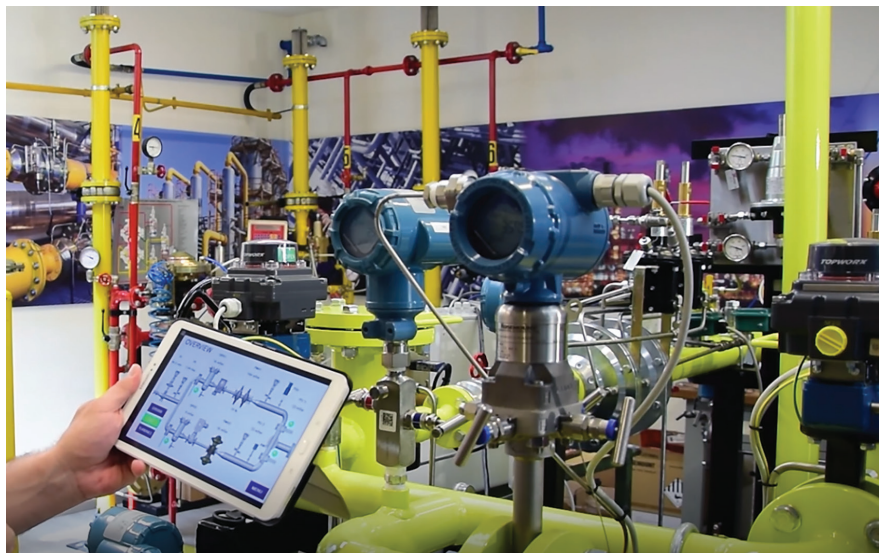

Emerson Spare Parts Services

Our customers' gas networks have thousands or tens thousands of pressure regulators installed that operate continuously.

The possibility of always having original spare parts available is essential to ensure the maintenance of the equipment and the safety of the network.

The use of non-original parts can lead to poor performance and operational inefficiencies.

Emerson spare parts kits are packaged in vacuum blister packs that ensure optimal protection of the parts, ensuring a longer storage life.

Thanks to Emerson's continuous research, the new **ECO blister®** packaging is made with 100% recyclable materials, to protect the environment as effectively as protecting spare parts.

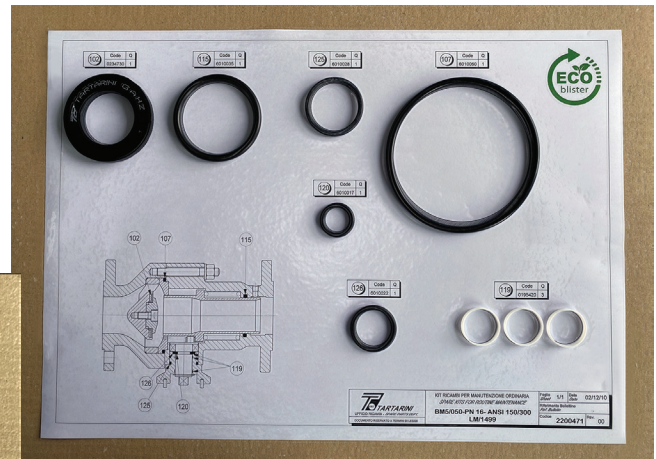
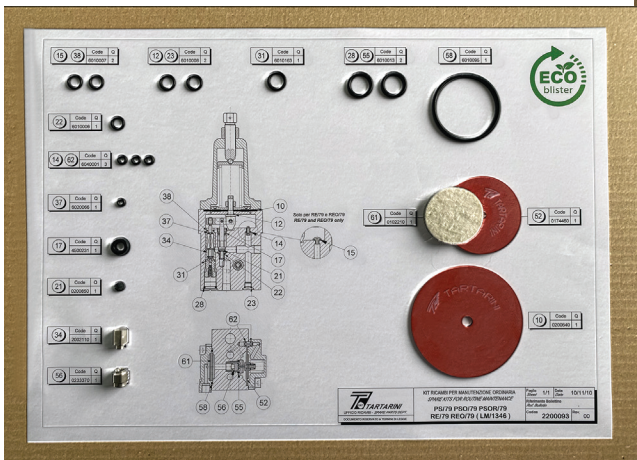

✉ Webadmin.Regulators@emerson.com

🔍 Emerson.com

📘 Facebook.com/EmersonAutomationSolutions

🌐 LinkedIn.com/company/emerson-automation-solutions

🐦 Twitter.com/emr_automation

Emerson Automation Solutions

Americas

McKinney, Texas 75070 USA

T +1 800 558 5853
+1 972 548 3574

Europe

Bologna 40013, Italy
T +39 051 419 0611

Asia Pacific

Singapore 128461, Singapore

T +65 6777 8211

Middle East and Africa

Dubai, United Arab Emirates
T +971 4 811 8100

Emerson Process Management s.r.l.

Emerson Automation Solutions - Stabilimento di/Site of: Castel Maggiore - Bologna
Sede Legale/Legal Entity: Piazza Meda 5, 20121 Milano, Italy
Sede Amministrativa/Administrative Headquarters: OMT Tartarini, Via Clodoveo Bonazzi 43,
40013 Castel Maggiore (Bologna), Italy
C.F. - P.I. e R.I. di MI 13186130152 - REA di MI/n.1622916
Direz. e Coord. (art. 2497 bis CC): EMERSON ELECTRIC CO. St. Louis (USA) Socio Unico

D352276X012 © 2017, 2022 Emerson Process Management Regulator Technologies, Inc. All rights reserved. 06/22.
The Emerson logo is a trademark and service mark of Emerson Electric Co. All other marks are the property of their prospective owners. Tartarini™ and Fisher™ are a business of Emerson Automation Solutions.

The contents of this publication are presented for information purposes only, and while effort has been made to ensure their accuracy, they are not to be construed as warranties or guarantees, express or implied, regarding the products or services described herein or their use or applicability. All sales are governed by our terms and conditions, which are available on request. We reserve the right to modify or improve the designs or specifications of our products at any time without notice.

Emerson Process Management Regulator Technologies, Inc does not assume responsibility for the selection, use or maintenance of any product. Responsibility for proper selection, use and maintenance of any Emerson Process Management Regulator Technologies, Inc. product remains solely with the purchaser.

