

September 2018

Electric Pilot Heater

SUMMARY

Introduction.....	1
Characteristics.....	2
Labelling	2
Dimensions and Weights	2
Installation	3
Commissioning	4
Maintenance	4
Spare Parts	5
Declaration of Conformity.....	6

WARNING

Failure to follow these instructions or to properly install and maintain this equipment could result in an explosion and/or fire causing property damage and personal injury or death.

Fisher™ electric pilot heater must be installed, operated and maintained in accordance with federal, state and local codes, rules and regulations and Emerson Process Management Regulator Technologies, Inc. instructions.

If the electric pilot heater vents gas or leak develops in the system, service to the unit may be required. Failure to correct trouble could result in a hazardous condition.

Call a gas service person to service the unit. Only qualified person must install or service the device.

INTRODUCTION

Scope of the Manual

This manual provides installation, startup, maintenance and parts ordering information for the electric pilot heater Type RPE.



Figure 1. Type RPE

Product Description

The electric pilot heater Type RPE is used for reheating gas supplying pressure reducing regulator pilots to avoid the inconveniences caused by freezing which occurs during large pressure drops and/or low ambient temperatures.

A “regulator bottom” version exists.

The Type RPE consists of :

- An explosion-proof junction box
- A thermometer pocket containing the heating element and a probe
- A heater tube (not present on “regulator bottom” version)
- A thermostat in charge of temperature regulation

The Type **RPE** is in conformity with the Directive for Equipment or protective system intended for use in potentially explosive atmospheres 2014/34/UE. It is classified under group II, category 2.

Type RPE

CHARACTERISTICS

Table 1. Electric Pilot Heater Type RPE Characteristics

OPERATING PRESSURE		
Heater tube	PS	100 bar max.
Thermometer pocket		
ELECTRICAL MATERIAL FOR EXPLOSIVE ATMOSPHERES		
Group according to directive 2014/34/UE	Group II	
Category according to directive 2014/34/UE	Category 2	
Protection	Ex db IIC T2 Gb	
Certificate	CML 18 ATEX 1081	
Power supply	230 V 50-60 Hz	
Power consumption	140 W	
Recommended operating temperature	0 to 30 °C	
Max. allowable admitted temperature	60 °C	
RECOMMENDED THERMOSTAT SETTINGS		
Selector for temperature A range	0/30	
Adjustment for B setting	30	
Differential selector C	2	

TEMPERATURE MEASUREMENT		
Interchangeable thermic probe	10 kΩ	
HEATER		
Two interchangeable heating cartridges	280 W - 230 V	
Connected in series	140 W	
TEMPERATURE REGULATION RANGE		
Thermostat	- 30 to + 90 °C	
POWER SUPPLY		
Power relay	I max	2 A
	U	250 V~
PROTECTION		
Thermostat	2 A	
Power relay	2 A	
FLUID		
Gas 1 st and 2 nd family according to EN437. The gas must be non corrosive, clean and dry.		

Materials

Heater tube	Steel
Thermometer pocket	Steel
Junction box	Aluminum

LABELLING

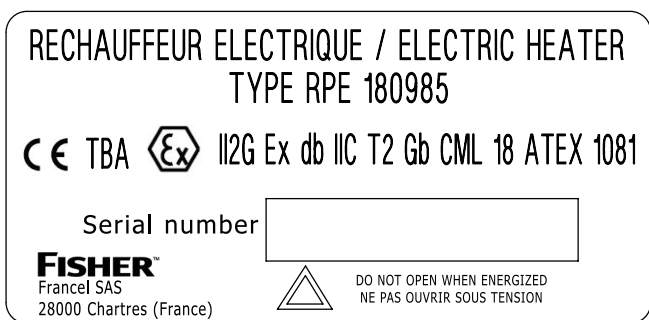
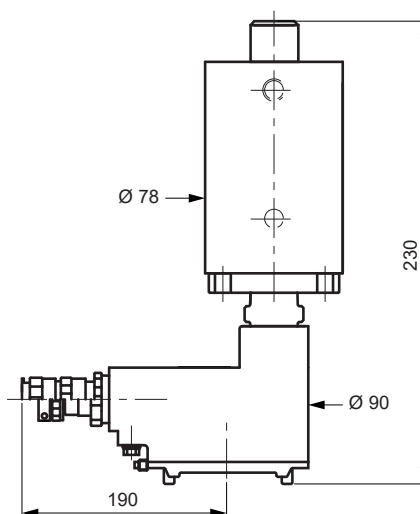

Figure 2. Electric Pilot Heater Type RPE Label

DIMENSIONS AND WEIGHTS



Heater only	: 1,4 kg
Heater + heating element:	4,5 kg

Figure 3. Electric Pilot Heater Type RPE Dimensions and Weights

INSTALLATION

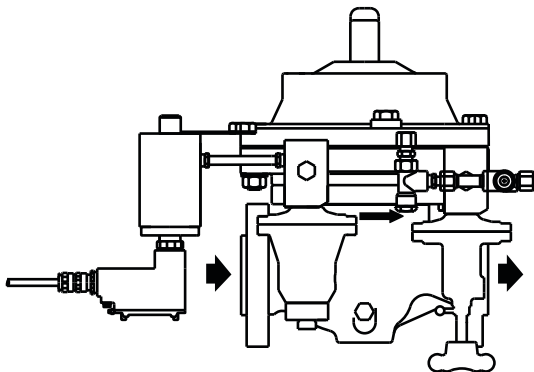

Figure 4. Type RPE Electric Pilot Heater Installation

Assembly

Electrical pilot heater (with heating element)

The Type RPE is assembled with the vertical thermometer pocket axe using the fixing part supplied with the regulator actuator bolt.

Electrical Connections

Electrical Type RPE box: Packing gland 3/4" NPT for cable snap-on.

Electrical wiring: Customer (according to Figure 5)

Recommended wiring: U-1000 RVFV, according to NF C32-322, type class 2.5, conductors 1,5 mm².

Note: the electrical terminals 4 and 6 of the thermostat (key 2) must be shunted to cut off supply in the case of rupture of the thermal probe (key 5).

Note: the electrical terminals 2 and 3 of the Type RPE connector block (key 4) must be shunted so that the heating elements (key 6) are connected in series.

Note: the thermostat (key 2) and the power relay (key 3) must be protected by 2A fuses (protection against short-circuit of the heating elements).

Note: the thermostat (key 2) and the power relay (key 3) are assembled on a symmetrical DIN rail.

Pneumatic Connections

The Type RPE is to be installed between the pilot filter and the pre-expansion relay.

Inlet/Outlet: 1/4" NPT - tube 8/10 (regardless of the gas flow).

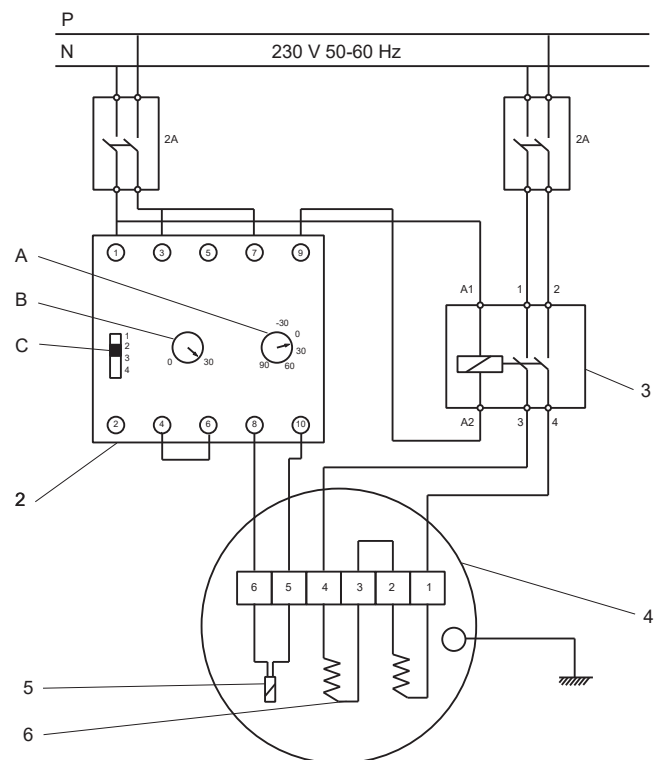

Figure 5. Assembly on Symmetrical DIN Rail

Regulator bottom electrical heater

The Type RPE is assembled on the regulator bottom with 4 fixing screws M8 x 20.

The Type RPE can be installed in an explosive risk zone.

The thermostat and power relay must be installed in a non-explosive risk zone.

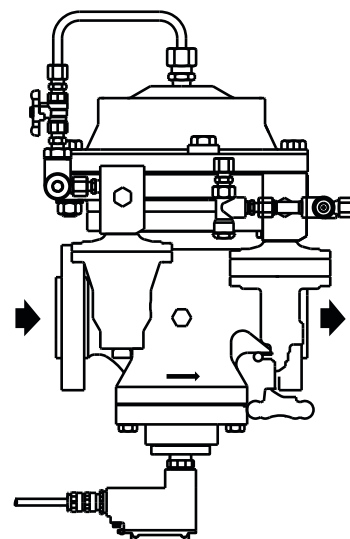

Figure 6. Type RPE Regulator Bottom Electrical Heater Installation



WARNING

Personal injury or equipment damage, due to bursting of pressure-containing part may result if this device is overpressured or is installed where service conditions could exceed the limits given in the Characteristics section and on the appropriate nameplate or where conditions exceed any rating of the adjacent piping or piping connections.

To avoid such injury or damage, provide pressure-relieving or pressure-limiting devices to prevent service conditions from exceeding those limits.

Also, be sure the installation is in compliance with all applicable codes and regulations.

Additionally, physical damage to the device can cause personal injury and property damage due to bursting of pressure containing parts.

To avoid such injury and damage, a possible approach could be e.g. install the device in a safe location.

All interventions on the equipment should only be performed by qualified and trained personnel.

The thermometer pocket's axis is to be installed vertically.

A support must be used to avoid pressure force on the regulator's body.

No modification should be made to the structure of the equipment (drilling, grinding, soldering...).

Verify that the inlet side is protected by an appropriate device(s) to avoid exceeding the limits of utilization (PS,TS).

Verify that the limits of utilization correspond to the appropriate operation conditions.

The equipment should not receive any type of shock.

Fire, seismic and lightning are not taken into consideration in standard regulators.

If required, a special product selection and/or specific calculations may be supplied according to specific requirement.

The user should verify or carry out a protection adapted to the environment.

COMMISSIONING



WARNING

All interventions on the equipment should only be performed by qualified and trained personnel.

Preliminary Verifications

Thermostat start-up positions

- Temperature range selector (A) - 0/30 °C
- Adjustment of the temperature setting (B) - 30
- Differential selector (C) - 2

Position before commissioning

- Pilot feeding valve

Closed

Commissioning

- Pilot feeding valve

Open slowly

The equipment is commissioned.

MAINTENANCE



WARNING

To avoid personal injury or property damage from sudden release of pressure, isolate the electric pilot heater Type RPE from the pressure system and release all pressure from the main valve before performing maintenance operations.

Servicing Check

Recommended frequency

- Once a year minimum.

Verification

- Probe, heating cartridges.

Replacement

- In case of visible wear and/or tear in these parts, replace them.

Precautions Before Disassembly

- Close the pilot feeding valve.
- Bleed of the pressure from the heater tube.
- Switch off the power supply.

Disassembly

- Unscrew the junction box's cover (key 10).
- Unscrew the M3 screw (key 9) and carefully take out the screw (key 9), the nut (key 8), the washer (key 7) and the O-ring (key 6).
- Pull out the heating cartridges (key 5) and the probe (key 4) and check for wear and/or tear.

SPARE PARTS



WARNING

If the Type RPE electric pilot heater was on before this operation, heating cartridges may be hot. If it is the case, wait until cool off before doing the maintenance operation.

- If a replacement is needed, unscrew the screw from the terminal block related to the element to change, take off the element and put a new one in the same terminals.

Reassembly

- Perform above operations in reverse order.
- Lightly lubricate heating cartridges before putting them back in the thermometer pocket.

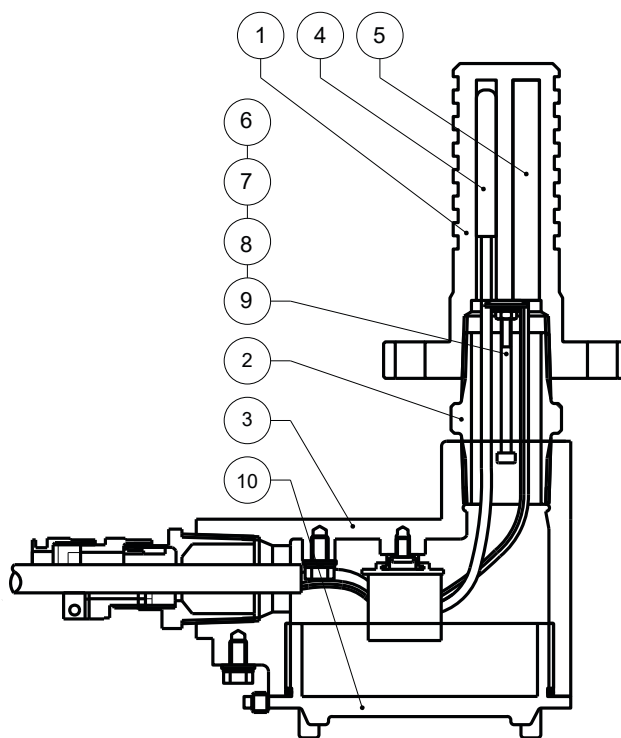

Figure 7. Electric Pilot Heater Type RPE Schematic

Table 2. Type RPE Electric Pilot Heater Spare Parts



KEY	DESCRIPTION	QTY	REFERENCE
-	Type RPE+Thermostat+Relay	1	FA197519X12
2 (Figure 6)	Thermostat	1	FA461328X12
-	Relay	2	FA461330X12
4 (Figure 7)	Probe	1	FA461363X12
5 (Figure 7)	Heating cartridge	2	FA461365X12

Type RPE

DECLARATION OF CONFORMITY

We declare that the electrical heaters, Type RPE, are aimed to put on the market for usage in explosive atmospheres and that they apply to the following:

- articles of the directive 2014/34/UE
- norms: • EN 60079-0: 2012
 - EN 60079-1: 2014

CML 18ATEX11081
Issue 0

11 Description
Electric heater type RPE 180 985.
- The heater is to:
- Maintain a minimum temperature in the body of a regulator in 'zero flow' to assist start up.
- Maintain a minimum temperature in the control circuit of a pressure regulator.
- Options:
- Electric pilot heater (with heating pot).
- Regulator bottom electric heater (without heating pot).
The temperature regulation is carried out through a relay, by a probe HAGER type EK083 and through a multi-range thermostat HAGER type EK 186 set to maximum 60°C (or equivalent).
The thermowell of the RPE is constantly bathing in the non-flammable gas. Around the RPE, an explosive atmosphere may occur, when:
- Opening of a valve.
- Opening of a vent.
- Leakage at a sealed connection.
If the sensor is switched off, the heating elements are switched off.
The RPE can operate in the absence of gas circulation.
The thermowell is be mounted vertically.
Rating: 230 VAC – 280 W- 50/60 Hz
The heater is fitted with a 3/4 NPT flameproof cable gland.

12 Certificate history and evaluation reports

Issue	Date	Associated report	Notes
0	06 Apr 2018	R11598A/00	Issue of prime certificate

Note: Drawings that describe the equipment or component are listed in the Annex.

13 Conditions of manufacture
The following conditions are required of the manufacturing process for compliance with the certification.



13.1 Where the product incorporates certified parts or safety critical components the manufacturer shall ensure that any changes to those parts or components do not affect the compliance of the certified product that is the subject of this certificate.

14 Special Conditions for Safe Use (Conditions of Certification)
None.

This certificate shall only be copied in its entirety and without change
www.CMLEx.com

2 of 2

Version 7.0 Approval: Approved

CML 18ATEX1081
Issue 0

EU Type Examination Certificate CML 18ATEX1081 Issue 0

- 1 Equipment intended for use in Potentially Explosive Atmospheres Directive 2014/34/EU
- 2 Equipment **Electric Heater Type RPE 180 985**
- 3 Manufacturer **FRANCEL SAS** [Brand name FISHER]
- 4 Address Business Park
3 avenue Victor Hugo,
CS80125
28008 CHARTRES Cedex
France
- 5 The equipment is specified in the description of this certificate and the documents to which it refers.
- 6 Certification Management Limited, Unit 1 Newport Business Park, New Port Road, Ellesmere Port CH65 4LZ, UK, Notified Body Number 2503, in accordance with Article 17 of Directive 2014/34/EU of the European Parliament and of the Council, dated 26 February 2014, certifies that this equipment has been found to comply with the Essential Health and Safety Requirements relating to the design and construction of equipment intended for use in potentially explosive atmospheres given in Annex II to the Directive.
The examination and test results are recorded in the confidential reports listed in Section 12.
- 7 If an 'X' suffix appears after the certificate number, it indicates that the equipment is subject to conditions of safe use (affecting correct installation or safe use). These are specified in Section 14.
- 8 This EU Type Examination certificate relates only to the design and construction of the specified equipment or component. Further requirements of Directive 2014/34/EU Article 13 apply to the manufacture of the equipment or component and are separately certified.
- 9 Compliance with the Essential Health and Safety Requirements, with the exception of those listed in the confidential report, has been demonstrated through compliance with the following documents:
- 10 The equipment shall be marked with the following:

 Ex db IIC T2 Gb
 Ta = -20°C to +40°C

This certificate shall only be copied in its entirety and without change
www.CMLEx.com

1 of 2



 H.M Amos MIET
 Technical Manager

Figure 8. Examination Certificates



Certificate Annex

Certificate Number CML 18ATEX1081

Equipment Electric heater Type RPE 180 985

Manufacturer FRANCEL SAS [Brand name FISHER]

The following documents describe the equipment or component defined in this certificate:

Issue 0

Drawing No	Sheets	Rev.	Approved date	Title
DT 028	1 to 33	0	06 Apr 2018	DOCUMENTATION TECHNIQUE
142364	1 of 1	A	06 Apr 2018	DOIGT DE GANT
142365	1 of 1	A	06 Apr 2018	MAMELON REPRIS
ATEX-FA180985	1 of 1	-/-	06 Apr 2018	RECHAUFFEUR ELECTRIQUE
FA180985	1 of 1	BB	06 Apr 2018	RECHAUFFEUR ELECTRIQUE
D103706XFR2	1 to 4	-/-	06 Apr 2018	NOTICE TECHNIQUE
FA142388	1 to 3	CE	06 Apr 2018	IDENTIFICATION PLATE RPE INDEX

This certificate shall only be copied in its entirety and without change
www.CML-EX.com

1 of 1

Version: 7.0 Approval: Approved

Figure 8. Examination Certificates (continue)

Type RPE

 Webadmin.Regulators@emerson.com

 Fisher.com

 Facebook.com/EmersonAutomationSolutions

 LinkedIn.com/company/emerson-automation-solutions

 Twitter.com/emr_automation

Emerson Automation Solutions

Americas

McKinney, Texas 75070 USA
T +1 800 558 5853
+1 972 548 3574

Europe

Bologna 40013, Italy
T +39 051 419 0611

Asia Pacific

Singapore 128461, Singapore
T +65 6770 8337

Middle East and Africa

Dubai, United Arab Emirates
T +971 4 811 8100

*Francel SAS, 3 Avenue Victor Hugo, CS 80125, Chartres 28008, France
SIRET 552 068 637 00057 APE 2651B, N° TVA : FR84552068637, RCS Chartres B 552 068 637,
SAS capital 534 400 Euro*

D103694X012 © 2017, 2018 Emerson Process Management Regulator Technologies, Inc. All rights reserved. 09/18.

The Emerson logo is a trademark and service mark of Emerson Electric Co. All other marks are the property of their prospective owners. Fisher™ is a mark owned by Fisher Controls International LLC, a business of Emerson Automation Solutions.

The contents of this publication are presented for information purposes only, and while effort has been made to ensure their accuracy, they are not to be construed as warranties or guarantees, express or implied, regarding the products or services described herein or their use or applicability. All sales are governed by our terms and conditions, which are available on request. We reserve the right to modify or improve the designs or specifications of our products at any time without notice.

Emerson Process Management Regulator Technologies, Inc does not assume responsibility for the selection, use or maintenance of any product. Responsibility for proper selection, use and maintenance of any Emerson Process Management Regulator Technologies, Inc. product remains solely with the purchaser.

