

December 2020

# Type 63EG-98HM Pilot-Operated Relief Valve or Backpressure Regulator

## Introduction

The Type 63EG-98HM can be used for gas, liquid or steam applications. For applications up to 450°F / 232°C, the Type 63EG-98HM utilizes high temperature Ethylenepropylene (EPR) or Perfluoroelastomer (FFKM) for Class VI shutoff. If used in a corrosive service, Perfluoroelastomer (FFKM) and other elastomers are available options that offer superior resistance to heat and most corrosive chemicals.

When using the Type 63EG-98HM with a corrosive liquid, usually water or a water-containing solution, the valve materials must be selected with care. For aqueous solutions, use a Stainless steel linear cage or Whisper Trim™ III Cage and body flange to ensure valve plug travel on a corrosion-free surface.

The Type 63EG-98HM is not an ASME certified device.

## Features

- **Variety of Construction Materials**—WCC steel and CF8M Stainless steel are standard constructions. Alloy 20, Hastelloy® C and Monel® are available options upon request.
- **Low Build-up Capability**—Minimal build-up pressure is required for main valve to achieve wide-open flow.
- **Chemically Compatible Elastomers**—Perfluoroelastomer (FFKM) is available for corrosive chemical applications.
- **No Assembly Adjustments Required**—Precise machining ensures that the main valve plug shuts off at both the port and upper seals at the same time.
- **Fast Speed of Response**—High gain piloting system for faster response than standard piloting system.
- **Excellent Overpressure Protection**—Superior pump bypass regulator for overpressure protection in pump recirculation applications.
- **NACE Availability**—Optional materials available for applications handling sour gases. These constructions comply with recommendations of the NACE International standards MR0175 and/or MR0103.

Hastelloy® C is a mark owned by Haynes International, Inc.  
Monel® is a mark owned by Special Metals Corporation



W6866

**Figure 1.** Type 63EG-98HM Pilot-Operated Relief Valve or Backpressure Regulator

- **Tight Shutoff**—Elastomer seats for Class VI shutoff on high temperature applications to 450°F / 232°C.
- **Easily Converted to Differential Control**—The pilot is ready for differential backpressure control with the addition of a sealing washer on the adjusting screw.
- **Labor-Saving Trim**—Main valve body can stay in-line during maintenance. Tested trim packages can be made up and stocked ahead of time for fast replacement.
- **Versatility in Both Liquid and Gas Service**—The pilot exhaust port and standard tapped pilot spring case each come with removable vent for remote piping when necessary. The standard tapped pilot spring case comes with an optional gasketed closing cap that permits pressure loading for remote pneumatic adjustment of the set pressure. For remote upstream registration, the pilot supply tubing may be disconnected at the 1/4 NPT main valve body tapping and this tapping plugged.
- **Arctic Temperature Constructions**—For process temperatures as low as -76°F / -60°C.

# Type 63EG-98HM

## Specifications

This section lists the specifications for Type 63EG-98HM relief valves or backpressure regulators. Factory specification is stamped on the nameplate fastened on the regulator at the factory.

### Main Valve Body Sizes and End Connection Styles<sup>(1)(2)</sup>

See Table 1

### Maximum Design Pressure<sup>(3)</sup>

600 psig / 41.4 bar or body rating limit, whichever is lower

### Maximum Operating Relief (Inlet) Pressure Including Build-up<sup>(2)(3)</sup>

450 psig / 31.0 bar or body rating limit, whichever is lower

### Maximum Outlet Pressure<sup>(2)(3)</sup>

450 psig / 31.0 bar

### Maximum Differential Pressure<sup>(2)</sup>

400 psig / 27.6 bar

### Port Diameter and Valve Plug Travels

See Table 2

### Relief Set Pressure/Backpressure Control Ranges<sup>(4)</sup>

See Table 3

### Flow Coefficients

See Table 4

### Main Valve IEC Sizing Coefficients

See Table 5

### Differential and Build-up Pressure Requirements<sup>(2)</sup>

See Table 6

### Main Valve Flow Characteristics

Linear (**standard**) or Whisper Trim™ III Cage (optional)

### Main Valve Flow Direction

In through seat ring and out through cage

### Temperature Capabilities<sup>(2)(5)</sup>

**Fluorocarbon (FKM):** 0 to 300°F / -18 to 149°C not acceptable in water or steam in excess of 200°F / 93°C

**Ethylene propylene (EPDM):**

*Steel:* -20 to 350°F / -29 to 177°C

*Stainless steel:* -40 to 350°F / -40 to 177°C

**Perfluoroelastomer (FFKM):** 0 to 450°F / -18 to 232°C

### Approximate Weights (Including pilot)

See Figure 4

### Pilot Control Line Connection

1/4 NPT

### Pilot Spring Case Connection

1/4 NPT

### Pilot Wide-Open Flow Coefficients

**C<sub>g</sub>:** 98; **C<sub>v</sub>:** 2.75; **C<sub>1</sub>:** 35

### 5/64 in. / 2.00 mm Fixed Bleed Restriction Coefficients

**C<sub>g</sub>:** 4.8; **C<sub>v</sub>:** 0.14

### Construction Materials

#### Type 63EG Main Valve

*Body and Body Flange:* WCC steel (**standard**), CF8M Stainless steel, Hastelloy® C, Monel® or Alloy 20 (optional)

*Cage:* 316 Stainless steel (**standard**), 416 Stainless steel, Hastelloy® C, Monel® or Alloy 20 (optional)

*Seat Ring and Valve Plug:* 416 Stainless steel (**standard**), 316 Stainless steel, Hastelloy® C, Monel® or Alloy 20 (optional)

*Spring:* Zinc-plated steel (**standard**) or Inconel® X750 (optional)

*Piston Ring:* Polytetrafluoroethylene (PTFE)

*Pipe Plug:* Steel (**standard**), 316 Stainless steel, Hastelloy® C, Monel® or Alloy 20 (optional)

*O-rings and Seals:* Fluorocarbon (FKM) (**standard**), Ethylene propylene (EPR) or Perfluoroelastomer (FFKM) (optional)

*Gaskets:* Composition (**standard**) or Graphite (optional)

#### Type MR98H

*Body:* WCC steel (**standard**), CF8M Stainless steel, Hastelloy® C, Monel® or Alloy 20 (optional)

*Spring Case:* WCC steel (**standard**) or CF8M Stainless steel (optional)

*Spring:* Steel (**standard**), Stainless steel, Inconel® X750 (optional)

*Trim:* 416 Stainless steel (**standard**), 316 Stainless steel, Hastelloy® C, Monel® or Alloy 20 (optional)

*Diaphragm:* 302 Stainless steel (**standard**), Ethylene propylene (EPR), Hastelloy® C, Monel® or Fluorocarbon<sup>(3)</sup> (FKM) (optional)

*Diaphragm Protector:* PTFE (optional)

*Diaphragm Gaskets:* Composition (**standard**) or graphite (optional)

*Seat:* Fluorocarbon (FKM) (**standard**), Ethylene propylene (EPR) or Perfluoroelastomer (FFKM) (optional)

*Adjusting Screw Sealing Washer for Pressure*

*Loaded Pilot:* Nitrile (NBR)

#### Mounting Parts

*Restrictor:* Steel (**standard**), 316 Stainless steel or Monel® (optional)

*Tubing:* Stainless steel (**standard**) or Monel® (optional)

*Fittings:* Steel (**standard**), 316 Stainless steel or Monel® (optional)

1. Other ratings and end connections can usually be supplied; consult the local Sales Office.

2. The pressure/temperature limits in this Bulletin and any applicable standard limitation should not be exceeded.

3. Fluorocarbon (FKM) diaphragm is limited to 300 psig / 20.7 bar.

4. Set pressure is defined as the pressure at which the pilot start-to-discharge.

5. Special low temperature constructions for process temperatures between -76 to 185°F / -60 to 85°C are available by request. The low temperature construction passed Emerson laboratory testing for lockup and external leakage down to -76°F / -60°C.

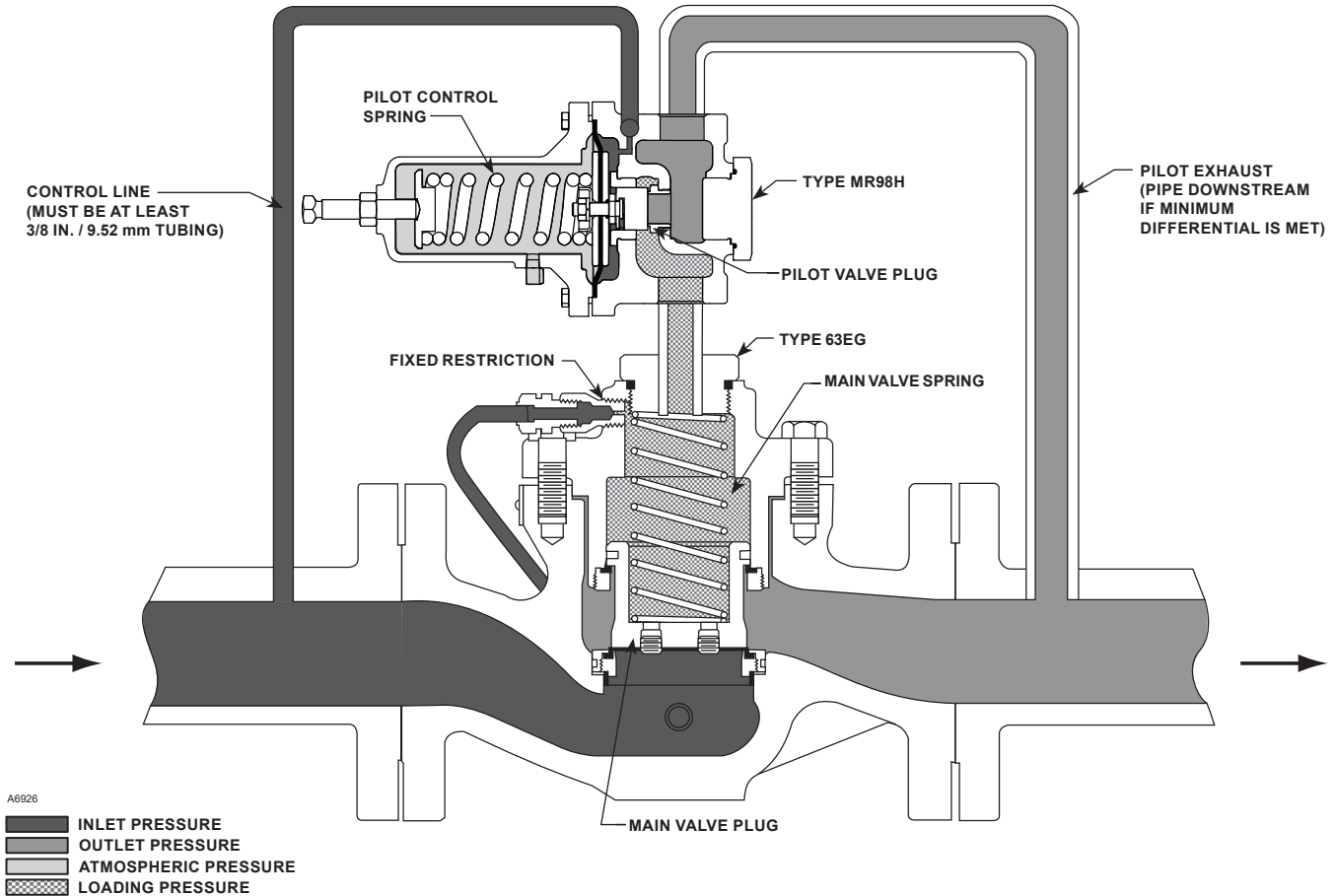

Figure 2. Operational Schematic

## Principle of Operation

As long as inlet pressure remains below set pressure, the pilot control spring keeps the pilot valve plug closed. This pressure provides the loading pressure that helps the main valve spring keep the main valve plug tightly shut off.

An inlet pressure rise above the set pressure overcomes the pilot control spring and opens the pilot valve plug. Loading pressure bleeds out the pilot exhaust faster than it can be replaced through the restriction. This permits inlet pressure to unbalance the main valve plug and open the main valve. As inlet pressure drops back to set pressure, the pilot control spring closes the pilot valve plug. Loading pressure again builds up to close the main valve plug.

## Example Sizing Problem:

To have a pump recirculation of oil and hold backpressure. The pump capacity is 180 GPM / 681 l/min, the oil has a specific gravity (G) of 1.00 and the temperature is ambient.

$$P_1 \text{ (Inlet Pressure)} = 25 \text{ psig} / 1.7 \text{ bar}$$

$$P_2 \text{ (Outlet Pressure)} = 15 \text{ psig} / 1.0 \text{ bar}$$

$$Q \text{ (Flow)} = 180 \text{ GPM} / 681 \text{ l/min}$$

$$\text{Calculated } C_v = 57$$

The differential pressure ( $P_1 - P_2$ ) is 10 psig / 0.69 bar. From Table 4, it is determined that NPS 2 / DN 50 main valve has the needed capacity. The pilot exhaust is piped downstream of the valve. With the pipeline size equaling the valve body size and using a linear cage, the  $C_v$  is equal to 63.3 as shown in Table 4. Since the differential pressure is less than 40 psig / 2.8 bar, Table 6 verifies that the yellow main valve spring can be used. To maintain the best accuracy, always use the lightest spring rate available. The pressure build-up to a wide-open state is 7 psi / 0.48 bar over setpoint. The setpoint on a relief valve or backpressure regulator is defined as when the pilot begins to bubble or open. Since the setpoint is 25 psig / 1.7 bar and the build-up required to fully open the regulator is 7 psi / 0.48 bar, the total upstream pressure would be at 32 psig / 2.2 bar. The differential pressure between  $P_1 - P_2$ , 32 - 15 psig / 2.2 - 1.0 bar, is 17 psi / 1.2 bar.

# Type 63EG-98HM

**Table 1. Body Sizes and End Connection Styles**

MAIN VALVE BODY SIZE		END CONNECTION STYLE
NPS	DN	
2	50	NPT, ASME CL150 RF, CL300 RF, CL600 RF or PN 16/25/40 flanged
3, 4, 6	80, 100, 150	ASME CL150 RF, CL300 RF, CL600 RF or PN 16/25/40 flanged
8 x 6	200 x 150	ASME CL150 RF, CL300 RF and CL600 RF flanged

**Table 2. Port Diameters and Valve Plug Travels**

BODY SIZE		PORT DIAMETER		VALVE PLUG TRAVEL	
NPS	DN	In.	mm	In.	mm
2	50	2-3/8	60	1-1/8	29
3	80	3-3/8	86	1-1/2	38
4	100	4-3/8	111	2	51
6	150	7-3/16	183	2	51
8 x 6	200 x 150	7-3/16	183	2	51

**Table 3. Relief Set Pressure or Backpressure Control Ranges**

CONTROL PRESSURE RANGE <sup>(1)</sup>		PART NUMBER	COLOR	SPRING FREE LENGTH		SPRING WIRE DIAMETER	
psig	bar			In.	mm	In.	mm
15 to 35	1.0 to 2.4	ERCA04288A0	Yellow	2.50	63.5	0.207	5.26
25 to 75	1.7 to 5.2	ERAA01910A0	Green	2.595	65.9	0.234	5.94
70 to 140	4.8 to 9.7	ERAA01911A0	Red	2.44	62.0	0.283	7.19
130 to 200	9.0 to 13.8	ERAA02889A0	Blue	2.250	57.2	0.331	8.41
100 to 375	6.9 to 25.9	ERCA04293A0	Unpainted	2.60	66.0	0.375	9.53
150 to 375 <sup>(2)</sup>	10.3 to 25.9 <sup>(2)</sup>	1N943427142	Unpainted	5.063	129	0.394	10.0

1. All springs may be backed off to 0 psig / 0 bar. However, highest capacities and best performances are obtained by using these springs in their recommended ranges.  
2. 150 to 375 psig / 10.3 to 25.9 bar spring range is only for the Type MR98HH pilot construction; consult the local Sales Office for this option.

However, the next consideration is making sure there is enough differential pressure between  $P_1$  and  $P_2$  to fully open the main valve. This minimum differential is determined by the valve plug area and the main valve spring. The smaller the valve plug area (i.e. body size) and the heavier the spring rate (i.e. red spring), the larger the differential requirements. In Table 6 the yellow main valve spring for NPS 2 / DN 50 body requires a differential pressure of 22 psi / 1.5 bar to fully open the main valve. Since it was calculated that 17 psi / 1.2 bar differential pressure is available to open the main valve, the minimum differential pressure can be subtracted from the calculated available differential pressure. In this case that would be  $22 - 17 = 5$  psi /  $1.5 - 1.2 = 0.34$  bar. Therefore, the inlet pressure would build-up an additional 5 psi / 0.34 bar in order to fully open the main valve. This will bring the inlet pressure to a total of 37 psi / 2.6 bar,  $32 + 5 = 37$  psi /  $2.2 + 0.35 = 2.6$  bar.

If the pilot were exhausting to atmosphere, the available differential pressure would be calculated at 25 psig / 1.7 bar setpoint + 7 psi / 0.48 bar build-up required less the pilot exhaust pressure 0 psig / 0 bar. After calculating the available differential pressure of  $32 - 0 = 32$  psig /  $2.2 - 0 = 2.2$  bar ( $P_1 - P_2$ ). With the minimum differential required to open the main valve at 22 psi / 1.5 bar, there is enough differential pressure to open the main valve without further build-up.

The  $C_v$  can be recalculated using the formula below based on the higher differential pressure between the inlet and outlet of the main valve. With a 32 psig / 2.2 bar inlet and a 10 psig / 0.69 bar outlet pressure, the required  $C_v$  of 38.3 is less than that based upon our original 10 psi / 0.69 bar differential pressure. This might be helpful in determining regulator size with near capacity limits.

$$C_v = Q \sqrt{\frac{G}{\Delta P}}$$

## Water and Steam Backpressure Relief

In water and steam applications, a Stainless steel body flange (bonnet) and cage ensure that the valve plug will travel on a corrosion-free surface. The cage supplied in standard Stainless steel constructions is a Whisper Trim™ Cage style. Please note flow coefficients for capacity information.

## Application Guidelines

For high cycling applications and/or fast on and off loads, such as solenoid valves and temperatures of 300°F / 149°C or less, Fluorocarbon (FKM) diaphragms are recommended. A PTFE protector comes standard with Fluorocarbon (FKM) diaphragms to prevent chemical attack.

If the application is above 300°F / 149°C and high cycling and/or fast on and off loads occur, a needle valve can be installed on the sense line to buffer the load on the diaphragm.

For high viscosity fluids, the manufacturer will supply a needle valve that can be used to replace the fixed restriction which allows the regulator gain to be adjusted. The build-up may vary from those shown in Table 6. The fixed restriction maintains the proportional gain of the regulator to the published values relating to build-up.

**Table 4. Flow Coefficients at Maximum Rated Travels**

BODY SIZE, NPS / DN	PIPING STYLE														
	Line Size Equals Body Size							2:1 Line Size to Body Size							
	Linear Cage			Whisper Trim™ III Cage				K <sub>m</sub>	Linear Cage			Whisper Trim III Cage			K <sub>m</sub>
	C <sub>g</sub>	C <sub>v</sub>	C <sub>1</sub>	C <sub>g</sub>	C <sub>v</sub>	C <sub>1</sub>	C <sub>g</sub>		C <sub>v</sub>	C <sub>1</sub>	C <sub>g</sub>	C <sub>v</sub>	C <sub>1</sub>		
2 / 50	2280	63.3	36.0	1970	54.7	36.0	0.71	2050	59.6	34.4	1830	52.2	35.0	0.71	
3 / 80	4630	132	35.1	3760	107	35.0	0.71	4410	128	34.4	3630	106	34.2	0.71	
4 / 100	7320	202	36.2	6280	180	34.8	0.71	6940	198	35.0	6020	171	35.2	0.71	
6 / 150	12,900	397	32.5	9450	295	32.0	0.71	12,100	381	31.7	9240	291	31.7	0.71	
8 x 6 / 200 x 150	17,800	556	32.0	10,500	300	35.0	0.71	17,100	534	32.0	10,270	293	35.0	0.71	

**Table 5. IEC Sizing Coefficients**

BODY SIZE, NPS / DN	X <sub>r</sub>	F <sub>b</sub>	F <sub>L</sub>
2 / 50	0.82	0.35	0.84
3 / 80	0.78	0.30	0.84
4 / 100	0.83	0.28	0.84
6 or 8 x 6 / 150 or 200 x 150	0.67	0.28	0.84

**Table 6. Minimum and Maximum Differential Pressures and Build-up Required for Wide-Open Flow**

BODY SIZE, NPS / DN	MAIN VALVE SPRING RANGE, SPRING PART NUMBER AND COLOR	MINIMUM DIFFERENTIAL PRESSURE REQUIRED FOR FULL STROKE <sup>(1)</sup>		BUILD-UP OVER SET PRESSURE REQUIRED FOR FULL STROKE		MAXIMUM DIFFERENTIAL PRESSURE	
		psi	bar	psi	bar	psi	bar
2 / 50	10 to 40 psig / 0.69 to 2.8 bar 14A6768X012 Yellow	22	1.5	7	0.48	40	2.8
	30 to 125 psig / 2.1 to 8.6 bar 14A6626X012 Green	30	2.1	9	0.6	125	8.6
	85 to 400 psig / 5.9 to 27.6 bar 14A6628X012 Red	90	6.2	23	1.6	400	28
3 / 80	10 to 40 psig / 0.69 to 2.8 bar 14A6771X012 Yellow	19	1.3	5	0.34	40	2.8
	30 to 125 psig / 2.1 to 8.6 bar 14A6629X012 Green	25	1.7	7	0.48	125	8.6
	85 to 400 psig / 5.9 to 27.6 bar 14A6631X012 Red	60	4.1	17	1.2	400	28
4 / 100	10 to 40 psig / 0.69 to 2.8 bar 14A6770X012 Yellow	16	1.1	4	0.28	40	2.8
	30 to 125 psig / 2.1 to 8.6 bar 14A6632X012 Green	20	1.4	6	0.4	125	8.6
	85 to 400 psig / 5.9 to 27.6 bar 14A6634X012 Red	55	3.8	16	1.1	400	28
6, 8 x 6 / 150, 200 x 150	10 to 40 psig / 0.69 to 2.8 bar 15A2253X012 Yellow	16	1.1	4	0.28	40	2.8
	30 to 125 psig / 2.1 to 8.6 bar 14A9686X012 Green	20	1.4	6	0.4	125	8.6
	85 to 400 psig / 5.9 to 27.6 bar 15A2615X012 Red	55	3.8	16	1.1	400	28

1. Minimum differential is defined as the difference between the inlet pressure to the main valve body and the exhaust pressure from the pilot outlet. If the pilot exhaust is piped to the immediate downstream system, the differential is between the inlet and outlet pressure of the backpressure regulator. The pilot exhaust also may be discharged to atmosphere.

## Installation

Not all codes or regulations will permit these units to be used as final overpressure protection devices.

On the Type 63EG relief valve, normal pressure drop assists shutoff. Therefore, leakage may result during any reverse pressure drop condition.

These valves may be installed in any position desired as long as the flow through the main valve complies with the flow arrow on the body. Pilot exhaust must be piped downstream of the relief valve plug or to a drain.

For safety during shutdown, vent valves will be required immediately upstream and downstream of the main valve on backpressure or bypass installations.

## Universal NACE Compliance

Optional materials are available for applications handling sour gases. These constructions comply with the recommendations of NACE International sour service standards.

The manufacturing processes and materials used by Emerson Process Management Regulator Technologies, Inc. assure that all products specified for sour gas service comply with the chemical, physical and metallurgical requirements of NACE MR0175 and/or NACE MR0103. Customers have the responsibility to specify correct materials. Environmental limitations may apply and shall be determined by the user.

# Type 63EG-98HM

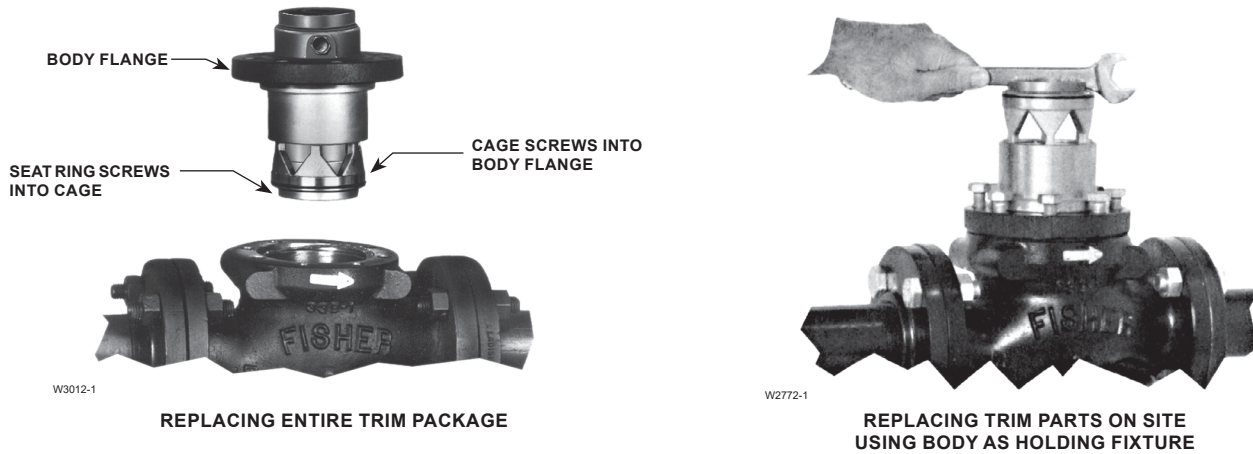
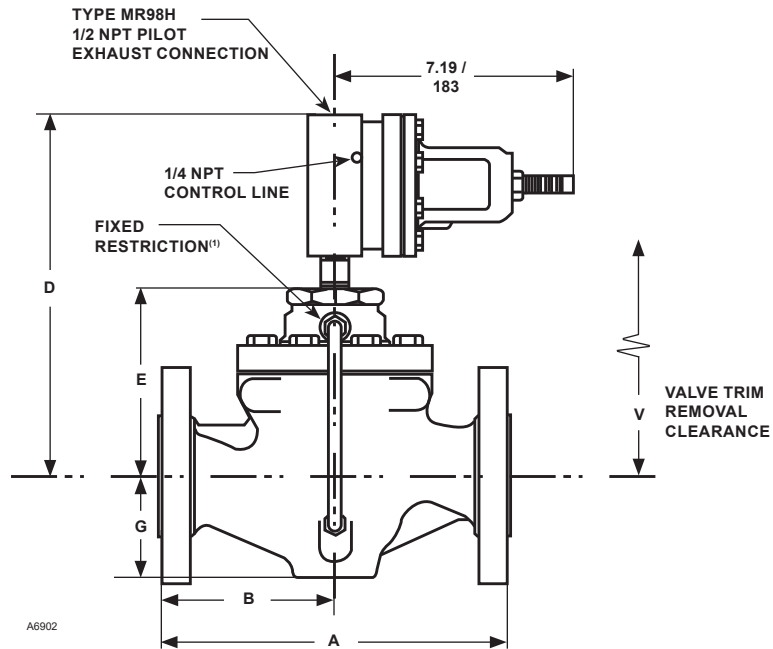

Figure 3. Easy-Maintenance Trim



IN. / mm

1. A needle valve can be used in place of the fixed restriction in high viscosity liquids or if instability of process conditions is present.

Figure 4. Dimensions

Table 7. Dimensions

BODY SIZE, NPS / DN	DIMENSION, IN. / mm									APPROXIMATE WEIGHT, LBS / kg
	A					D	E	G	V	
	NPT	CL150 RF	CL300 RF	CL600 RF	PN 16/25/40					
2 / 50	11.25 / 286	10.00 / 254	10.50 / 267	11.25 / 286	10.31 / 262	10.87 / 276	5.62 / 143	3.06 / 78	12.62 / 321	65 / 30
3 / 80	----	11.75 / 298	12.50 / 318	13.25 / 337	12.20 / 310	12.25 / 311	7.00 / 178	3.81 / 97	16.25 / 413	105 / 48
4 / 100	----	13.88 / 353	14.50 / 368	15.50 / 394	13.78 / 350	13.63 / 346	8.38 / 213	5.06 / 128	18.88 / 480	155 / 71
6 / 150	----	17.75 / 451	18.60 / 472	20.00 / 508	18.00 / 457	14.44 / 367	9.19 / 233	5.56 / 141	20.00 / 508	340 / 155
8 x 6 / 200 x 150	----	21.38 / 543	22.38 / 569	----	----	16.00 / 406	10.75 / 273	7.19 / 183	21.56 / 548	630 / 286

## Ordering Information

When ordering, complete the Ordering Guide page. Make sure to include the following:

For a standard installation or to obtain a noise prediction for your installation and service conditions, please complete the Specification Worksheet at the bottom of the Ordering Guide page.

Refer to the Specifications section on page 2. Carefully review each specification; then complete the Ordering Guide on page 7. If not otherwise specified, the pilot is factory set in the middle of the set pressure range.

Always specify the type numbers of other desired equipment as well as the main valve and pilot. Unless otherwise ordered, the standard-gain pilot restriction will be provided.

## Ordering Guide

### Body Size (Select One)

- NPS 2 / DN 50\*\*\*
- NPS 3 / DN 80\*\*\*
- NPS 4 / DN 100\*\*\*
- NPS 6 / DN 150\*\*\*
- NPS 8 x 6 / DN 200 x 150\*

### Body Material (Select One)

- WCC Steel\*\*\*
- CF8M Stainless steel\*\*
- Hastelloy® C\*
- Monel®\*
- Alloy 20\*

### End Connection Style (Select One)

- NPT, for NPS 2 only\*\*\*
- CL150 RF\*\*\*
- CL300 RF\*\*\*
- CL600 RF\*\*\*
- PN 16/25/40\* \_\_\_\_\_ specify rating  
(NPS 8 x 6 / DN 200 x 150 not available)

### Body Flange Material (Select One)

- ENC Coated WCC Steel\*\*\*
- ENC Coated CF8M Stainless steel\*\*
- ENC Coated Hastelloy® C\*
- ENC Coated Monel®\*
- ENC Coated Alloy 20\*
- Other \_\_\_\_\_ specify

### Main Valve Cage Type (Select One)

- Linear\*\*\*
- Whisper Trim™ III Cage\*\*

### Main Valve Cage Material (Select One)

- 316 Stainless steel (standard)\*\*\*
- 416 Stainless steel\*\*
- Hastelloy® C\*
- Monel®\*
- Alloy 20\*

### Main Valve Seat Ring and Valve Plug Material

(Select One)

- 416 Stainless steel (standard)\*\*\*
- 316 Stainless steel\*\*
- Hastelloy® C\*
- Monel®\*
- Alloy 20\*

### Main Valve Spring Color (Select One)

- 10 to 40 psig / 0.69 to 2.8 bar, Yellow\*\*
- 30 to 125 psig / 2.1 to 8.6 bar, Green\*\*\*
- 85 to 400 psig / 5.9 to 27.6 bar, Red\*\*\*

### Relief Set Pressure/Backpressure Control Range (Select One)

- 15 to 35 psig / 1.0 to 2.4 bar, Yellow\*\*\*
- 25 to 75 psig / 1.7 to 5.2 bar, Green\*\*\*
- 70 to 140 psig / 4.8 to 9.7 bar, Red\*\*\*
- 130 to 200 psig / 9.0 to 13.8 bar, Blue\*\*\*
- 100 to 375 psig / 6.9 to 25.9 bar, Unpainted\*\*\*
- 150 to 375 psig / 10.3 to 25.9 bar, Unpainted\*\*\*<sup>(1)</sup>

### Main Valve Spring Material (Select One)

- Zinc-plated steel\*\*\*
- Inconel® X750\*\*

### O-ring and Seal Material (Select One)

- Fluorocarbon (FKM)\*\*\*
- Ethylenepropylene (EPR)\*\*
- Perfluoroelastomer (FFKM)\*

### Gasket Material (Select One)

- Composition\*\*\*
- Graphite\*\*

### Tubing Material (Select One)

- Stainless steel (standard)\*\*\*
- Monel®\*

### Fitting Material (Select One)

- Steel (standard)\*\*\*
- 316 Stainless steel\*\*
- Monel®\*

### Restrictor Material (Select One)

- Steel\*\*\*
- 316 Stainless steel\*\*\*
- Monel®\*

### Pilot Body Material (Select One)

- WCC Steel (standard)\*\*\*
- CF8M Stainless steel\*\*
- Hastelloy® C\*
- Monel®\*
- Alloy 20\*

### Pilot Spring Case (Select One)

- WCC Steel (standard)\*\*\*
- CF8M Stainless steel\*\*

Hastelloy® C is a mark owned by Haynes International, Inc.  
Inconel® and Monel® are marks owned by Special Metals Corporation.  
1. 150 to 375 psig / 10.3 to 25.9 bar spring range is only for the Type MR98HH construction; consult the local Sales Office for this option.

- continued -

# Type 63EG-98HM

## Ordering Guide (continued)

### Pilot Diaphragm (Select One)

- 302 Stainless steel (**standard**)\*\*\*
- Fluorocarbon (FKM)\*\*\*
- Ethylenepropylene (EPR)\*\*
- Hastelloy® C\*
- Monel®\*

### PTFE Diaphragm Protector

- Yes

### Pilot Seat (Select One)

- Fluorocarbon (FKM) (**standard**)\*\*\*
- Ethylenepropylene (EPR)\*\*
- Perfluoroelastomer (FFKM)\*

### Pilot Trim (Select One)

- 416 Stainless steel\*\*\*
- 316 Stainless steel\*\*
- Hastelloy® C\*
- Monel®\*
- Alloy 20\*

Hastelloy® C is a mark owned by Haynes International, Inc.  
Monel® is a mark owned by Special Metals Corporation.

Regulators Quick Order Guide	
***	Readily Available for Shipment
**	Allow Additional Time for Shipment
*	Special Order, Constructed from Non-Stocked Parts. Consult your local Sales Office for Availability.
Availability of the product being ordered is determined by the component with the longest shipping time for the requested construction.	

### NACE Construction Required (Optional)

- Yes

### Main Valve Replacement Parts Kit (Optional)

- Yes, send one replacement parts kit to match this order.

### Pilot Replacement Parts Kit (Optional)

- Yes, send one replacement parts kit to match this order.

Specification Worksheet	
<b>Application:</b>	
Specific Use	_____
Line Size	_____
Fluid Type	_____
Specific Gravity	_____
Temperature	_____
Is this a Relief or Backpressure Application?	_____
<b>Pressure:</b>	
Maximum Inlet Pressure	_____
Downstream Pressure	_____
Differential Pressure	_____
Relief (Inlet) Set Pressure	_____
Maximum Flow	_____
<b>Accuracy Requirements:</b>	
Less Than or Equal To:	
<input type="checkbox"/> 5%	<input type="checkbox"/> 10% <input type="checkbox"/> 20% <input type="checkbox"/> 40%

 Webadmin.Regulators@emerson.com

 Fisher.com

 Facebook.com/EmersonAutomationSolutions

 LinkedIn.com/company/emerson-automation-solutions

 Twitter.com/emr\_automation

## Emerson Automation Solutions

### Americas

McKinney, Texas 75070 USA  
T +1 800 558 5853  
+1 972 548 3574

### Europe

Bologna 40013, Italy  
T +39 051 419 0611

### Asia Pacific

Singapore 128461, Singapore  
T +65 6777 8211

### Middle East and Africa

Dubai, United Arab Emirates  
T +971 4 811 8100

D102628X012 © 2000, 2020 Emerson Process Management Regulator Technologies, Inc. All rights reserved. 12/20.

The Emerson logo is a trademark and service mark of Emerson Electric Co. All other marks are the property of their prospective owners. Fisher™ is a mark owned by Fisher Controls International LLC, a business of Emerson Automation Solutions.

The contents of this publication are presented for informational purposes only, and while every effort has been made to ensure their accuracy, they are not to be construed as warranties or guarantees, express or implied, regarding the products or services described herein or their use or applicability. All sales are governed by our terms and conditions, which are available upon request. We reserve the right to modify or improve the designs or specifications of such products at any time without notice.

Emerson Process Management Regulator Technologies, Inc does not assume responsibility for the selection, use or maintenance of any product. Responsibility for proper selection, use and maintenance of any Emerson Process Management Regulator Technologies, Inc. product remains solely with the purchaser.

