

October 2017

Type 1367 High-Pressure Instrument Supply System with Overpressure Protection

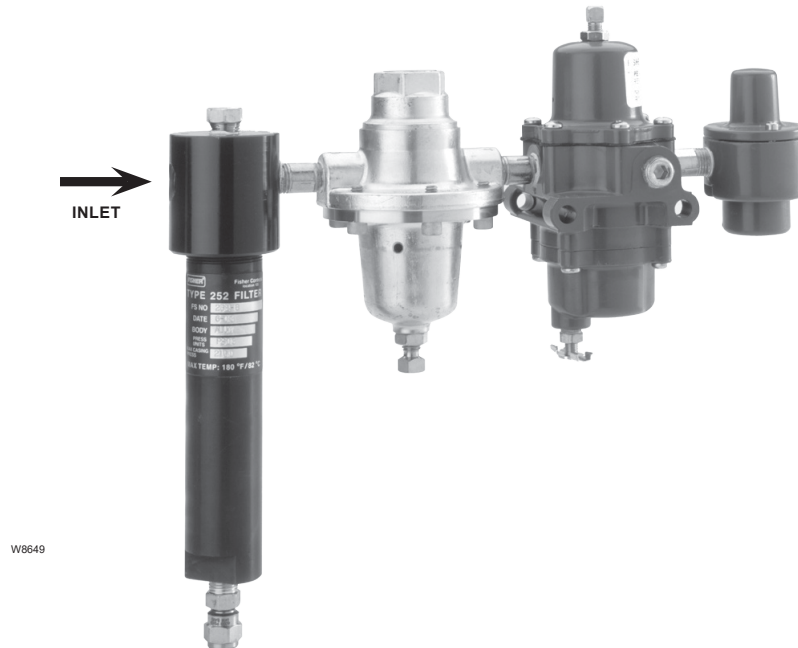

Figure 1. Type 1367 High-Pressure Instrument Supply System

Introduction

The Type 1367 high-pressure instrument supply system takes a pressure of up to 2000 psig / 138 bar and reduces it to a controlled pressure to be used for supplying a pneumatic instrument. This system consists of the following filters, regulators and relief valves:

- A Type 252 extended body filter with drain valve.
- A first-stage Type 1301F regulator with mounting bracket for an actuator yoke or casing.
- A Type H120 relief valve mounted in the side outlet of the Type 1301F regulator.
- A second-stage Type 67CF filter-style regulator, mounted on the Type 1301F regulator.
- A Type H800 or H120 relief valve nipple-mounted in the outlet of the Type 67CF regulator.

Features

- **Regulation and Overpressure Protection in One Complete Package** — This system provides two-stage pressure reduction with a non-adjustable relief valve matched to each regulator.
- **Installation Flexibility** — The Type 1367 system can be ordered for mounting on either the yoke or casing of an actuator.
- **NACE Capabilities** — For sour gas applications, the Type 1367 system is available in materials that comply with the recommendations of NACE International standard MR0175.
- **Capability for Continuous Moisture Removal** — The drain valves can be removed from both the Type 252 filter and the Type 67CF filter-style regulator, and tubing installed to provide continuous drains.

Type 1367

Specifications

The Specifications section on this page provides the ratings and other specifications for the Type 1367. Factory specifications are stamped on the nameplate fastened on the regulator at the factory.

Connection Size

Inlet and Outlet: 1/4 NPT

Type H800 Vent: 1/2 NPT with removable screen

Maximum Inlet Pressure⁽¹⁾

2000 psig / 138 bar

Fixed Relief Setting of Type H120 Relief Valve

150 psig / 10.3 bar

Outlet (Supply) Pressure Range

5 to 90 psig / 0.34 to 6.2 bar

Maximum Outlet (Supply) Pressure with Type 67CF Regulator Failed Wide-Open with:

Type H800 Relief Valve Relieving: 50 psig / 3.4 bar

Type H120 (Second Stage) Relief Valve Relieving: 5 psig / 0.34 bar over Type H120 setpoint

Construction Materials

Type 252 Filter

Body Material: Aluminum or Stainless steel

Filter Cartridge: Polyethylene

O-rings: Nitrile (NBR)

Drain Valve: 316 Stainless steel

Type 1301F Regulator

Body and Spring Case: Brass or Stainless steel

Disk: Polytetrafluoroethylene (PTFE)

Gaskets: Neoprene (CR) and Fluorocarbon (FKM)

All Other Parts: Brass and Stainless steel

Construction Materials (continued)

Type H120 Relief Valve

Disk: Nitrile (NBR)

Spring and Pin: Stainless steel

All Other Parts: Brass or Stainless steel

Type 67CF Regulator

Body and Spring Case: Aluminum or Stainless steel

Diaphragm and Plug: Nitrile (NBR) or

Fluorocarbon (FKM)

Stem: Brass, Aluminum, or Stainless steel

Filter: Polyethylene

All Other Parts: Steel and Stainless steel

Type H800 Relief Valve

Body and Spring Case: Aluminum

Diaphragm: Nitrile (NBR)

All Other Parts: Steel and Stainless steel

Temperature Capabilities⁽¹⁾

-20 to 150°F / -29 to 66°C (standard materials)

Approximate Weight

12 lbs / 5.4 kg

Dimensions

See Figure 3

1. The pressure/temperature limits in this Bulletin and any applicable standard or code limitation should not be exceeded.

Principle of Operation

The Type 252 filter helps remove dirt, rust, chips, scale and moisture from the incoming high-pressure supply before it enters the Type 1301F regulator. The Type 1301F regulator is set to reduce the incoming high-pressure to 100 psig / 6.9 bar. The reduced pressure from the Type 1301F regulator is then further reduced to the required outlet (supply) pressure. The Type 67CF regulator is normally set between 20 to 90 psig / 1.4 to 6.2 bar.

The first stage Type H120 relief valve helps protect the Type 67CF regulator by relieving if the reduced pressure from the Type 1301F regulator exceeds 150 psig / 10.3 bar. The Type H800 or H120 relief valve helps protect downstream equipment from

overpressure by starting to relieve if the reduced pressure from the Type 67CF regulator exceeds the relief valve setpoint. Air or gas flowing from one or both of the relief valves indicates that one or both of the regulators are worn or damaged and must be repaired or replaced immediately.

Ordering Information

When ordering a Type 1367 high-pressure instrument supply system, specify the type number, the pressure setting required, any construction material variations desired, and whether yoke or casing mounting is required.

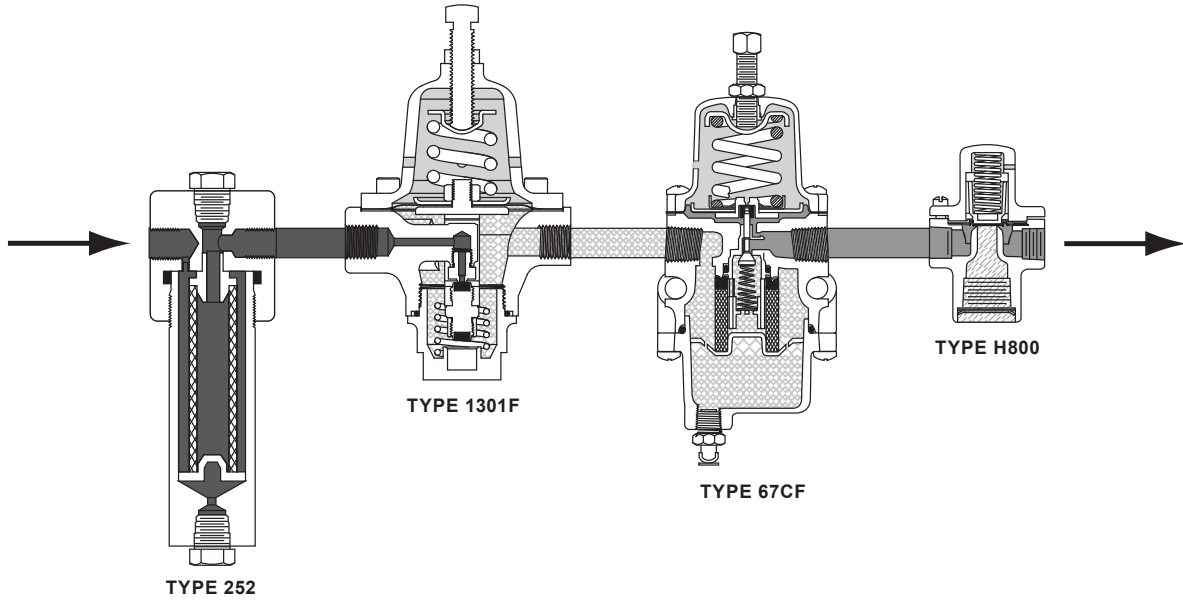

TYPE H120 RELIEF VALVE NOT SHOWN

- HIGH INLET PRESSURE
- ATMOSPHERIC PRESSURE
- INITIAL STEP-DOWN PRESSURE, 100 psig / 6.9 bar
- FINAL OUTLET PRESSURE, 5 TO 90 psig / 0.34 TO 6.2 bar
- RELIEF PRESSURE

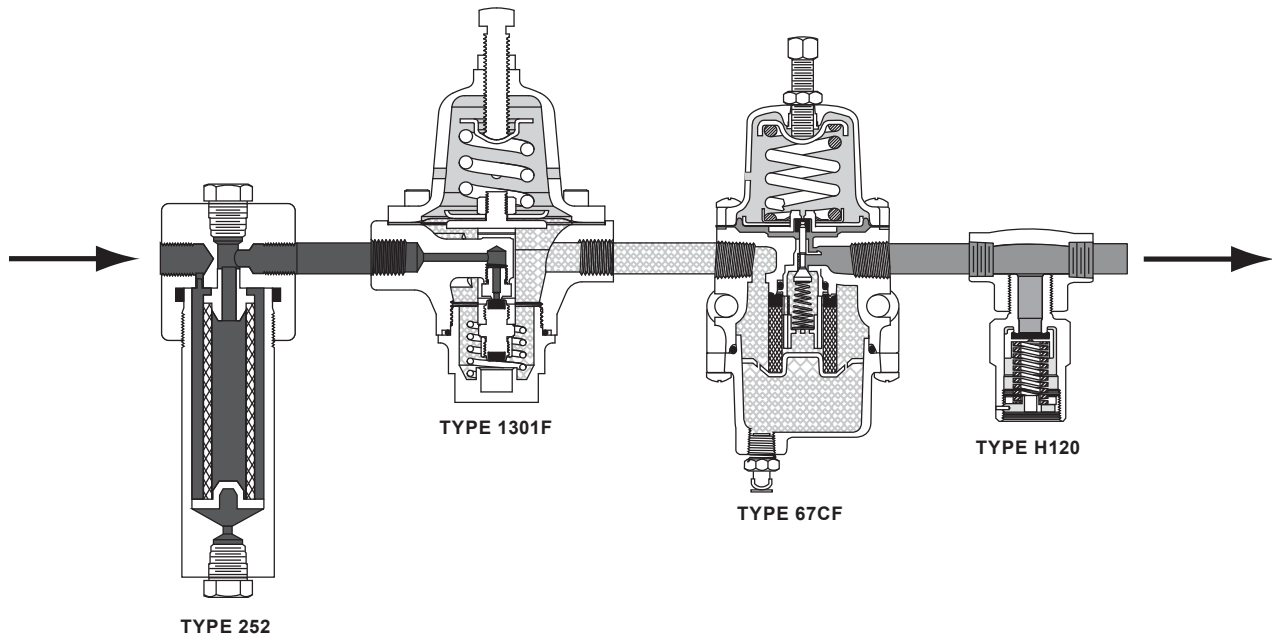

FIRST STAGE TYPE H120 RELIEF VALVE NOT SHOWN

- HIGH INLET PRESSURE
- ATMOSPHERIC PRESSURE
- INITIAL STEP-DOWN PRESSURE, 100 psig / 6.9 bar
- FINAL OUTLET PRESSURE, 5 TO 90 psig / 0.34 TO 6.2 bar
- RELIEF PRESSURE

Figure 2. Type 1367 Operational Schematic

Type 1367

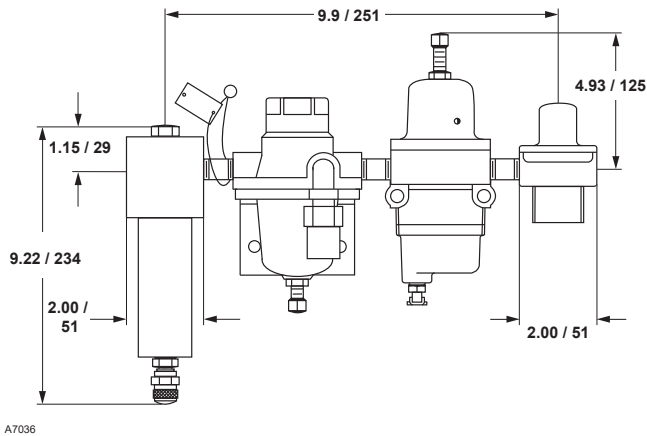

TYPE H120 RELIEF VALVE NOT SHOWN

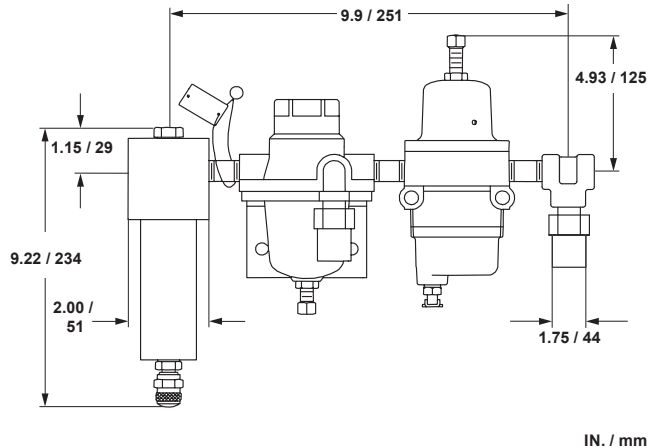

FIRST STAGE TYPE H120 RELIEF VALVE NOT SHOWN

Figure 3. Dimensions

✉ Webadmin.Regulators@emerson.com

🔍 Fisher.com

📘 Facebook.com/EmersonAutomationSolutions

🌐 LinkedIn.com/company/emerson-automation-solutions

🐦 Twitter.com/emr_automation

Emerson Automation Solutions

Americas

McKinney, Texas 75070 USA
T +1 800 558 5853
+1 972 548 3574

Europe

Bologna 40013, Italy
T +39 051 419 0611

Asia Pacific

Singapore 128461, Singapore
T +65 6770 8337

Middle East and Africa

Dubai, United Arab Emirates
T +971 4 811 8100

D100127X012 © 1994, 2017 Emerson Process Management Regulator Technologies, Inc. All rights reserved. 10/17.

The Emerson logo is a trademark and service mark of Emerson Electric Co. All other marks are the property of their prospective owners. Fisher™ is a mark owned by Fisher Controls International LLC, a business of Emerson Automation Solutions.

The contents of this publication are presented for information purposes only, and while effort has been made to ensure their accuracy, they are not to be construed as warranties or guarantees, express or implied, regarding the products or services described herein or their use or applicability. All sales are governed by our terms and conditions, which are available on request. We reserve the right to modify or improve the designs or specifications of our products at any time without notice.

Emerson Process Management Regulator Technologies, Inc. does not assume responsibility for the selection, use or maintenance of any product. Responsibility for proper selection, use and maintenance of any Emerson Process Management Regulator Technologies, Inc. product remains solely with the purchaser.

