

December 2019

# H200 Series Relief Valves



Figure 1. External View of H200 Series Relief Valve

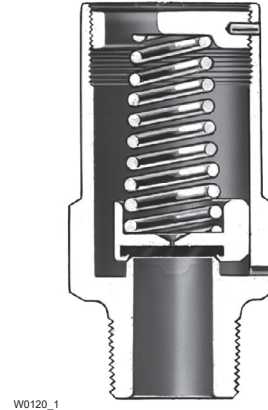

Figure 2. Sectional View of H200 Series Relief Valve

## Introduction

The H200 Series Pop™ relief valves, Figures 1 and 2, are self-operated relief valves with preset and pinned spring retainers. The inlet pressure registers directly on a spring-opposed poppet assembly which includes a Nitrile (NBR) disk. When the inlet gas pressure increases above the spring setting, the poppet and disk assembly is pushed away from the orifice. Springs are available that provide any relief pressure setting from 25 to 300 psig / 1.7 to 20.7 bar.

With this simple operation and wide spring setting selection, the H200 Series Pop relief valves may be used where venting to atmosphere is acceptable, where the process gas is compatible with the Nitrile (NBR) disk, where its relief capacity is adequate and where some pressure relieving tolerance is acceptable. Common applications include use on pneumatic control lines of air drills, jackhammers and other similar equipment and on farm tap installations. The H200 Series is comprised of the Types H202 and H203 relief valves with the difference being in the inlet connection size.

## Features

- **Space-Saving Construction** - Small relief valve size allows installation where space is limited.
- **Economical** - Low initial cost, easy installation and high capacity per dollar invested reduces total cost of having relief valve capabilities in your system.
- **Durable** - Brass body construction and stainless steel spring reduces susceptibility to corrosion damage and the preset, pinned spring retainer prevents relief valve setpoint tampering.

## Installation

This relief valve may be installed in any position but must be oriented so that gas discharged from the valve does not create a fire, toxic or explosion hazard. The relief valve should be protected from material and conditions that could clog the outlet side of the valve and affect the venting of gas.

A typical installation is shown in Figure 3. A Type P145 raincap is recommended for use with any H200 Series relief valve. Dimensions are shown in Figure 4.

The relief valve and installation should be checked for compliance with all applicable codes.

# H200 Series

## Specifications

This section lists the specifications for H200 Series external relief valves. Factory specifications are engraved on the body of the relief valve at the factory.

<p><b>Available Configurations and End Connections</b>  <b>Type H202:</b> 3/4 NPT connection  <b>Type H203:</b> 1 NPT connection</p> <p><b>Maximum Allowable Relief (Inlet) Pressure<sup>(1)</sup></b>  400 psig / 27.6 bar</p> <p><b>Relief Pressure Ranges<sup>(1)</sup></b>  See Tables 1 and 2</p> <p><b>Flow Capacity</b>  See Table 2</p> <p><b>Representative Wide-Open Sizing Coefficient</b>  C<sub>g</sub>: 405</p>	<p><b>Construction Materials</b>  <b>Body, Poppet and Spring Retainer:</b> Brass  <b>Disk:</b> Nitrile (NBR)  <b>Spring:</b> 302 Stainless steel</p> <p><b>Temperature Capabilities<sup>(1)</sup></b>  -20 to 160°F / -29 to 71°C</p> <p><b>Approximate Weight</b>  0.5 lbs / 0.2 kg</p> <p><b>Option</b>  Type P145 raincap</p>
---	--

1. The pressure/temperature limits in this Bulletin or any applicable code limitations should not be exceeded.

**Table 1. Relief Pressure Spring Ranges**

RELIEF PRESSURE SETTINGS		SPRING PART NUMBER	SPRING COLOR	RELIEF SETTING TOLERANCE	
psig	bar			psig	bar
25 to 30 31 to 55	1.7 to 2.1 2.1 to 3.8	1H485637022 1J152137022	Pink White	±5	±0.34
56 to 70 65 to 95 90 to 130	3.9 to 4.8 4.5 to 6.5 6.2 to 9.0	1P391137022 T1049037022 1F791337022	Blue Plain Purple	±8	±0.55
131 to 160 161 to 190 191 to 235 236 to 300	9.0 to 11.0 11.1 to 13.1 13.2 to 16.2 16.3 to 20.7	1F7912T0012 T12699T0012 1F790937022 1E954637052	Yellow Green Brown Plain	±15	±1.03

**Table 2. Relief Set Pressures and Capacities**

RELIEF SET PRESSURE <sup>(1)</sup>		SET PRESSURE PLUS BUILD-UP		FLOW CAPACITY <sup>(2)</sup>	
psig	bar	psig	bar	SCFH	Nm <sup>3</sup> /h
25	1.7	50	3.4	34,200	916
50	3.4	75	5.2	47,400	1270
75	5.2	100	6.9	60,000	1608
100	6.9	120	8.3	69,600	1865
125	8.6	150	10.3	83,400	2235
150	10.3	180	12.4	100,500	2693
175	12.1	210	14.5	117,600	3152
200	13.8	240	16.5	132,000	3538
225	15.5	270	18.6	150,000	4020
250	17.2	300	20.7	165,000	4422
275	19.0	330	22.7	180,000	4824
300	20.7	360	24.8	195,000	5226

1. This is the initial leak point, the point at which the relief valve begins to discharge.

2. 0.6 Specific Gravity Gas. To convert to equivalent capacities of other gases, multiply the table values by 0.775 for air or 0.789 for nitrogen. Multiply the flow obtained by 0.0268 to convert to (Nm<sup>3</sup>/h) at 0°C and 1.01 bar.

## Ordering Information

When ordering an H200 Series relief valve, specify the type number and the relief pressure setting required.

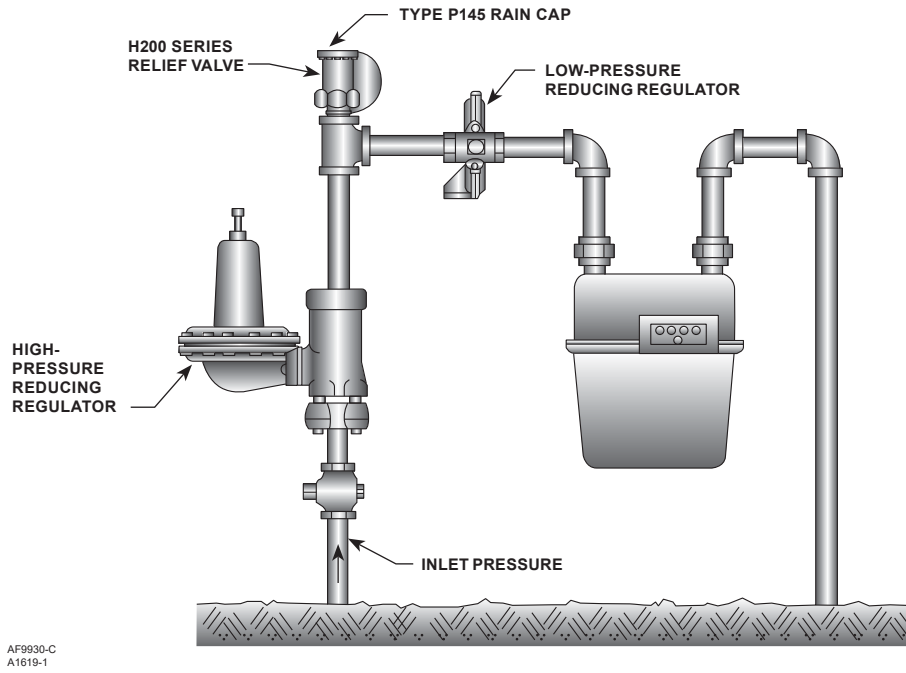

Figure 3. Typical Farm Tap Installation

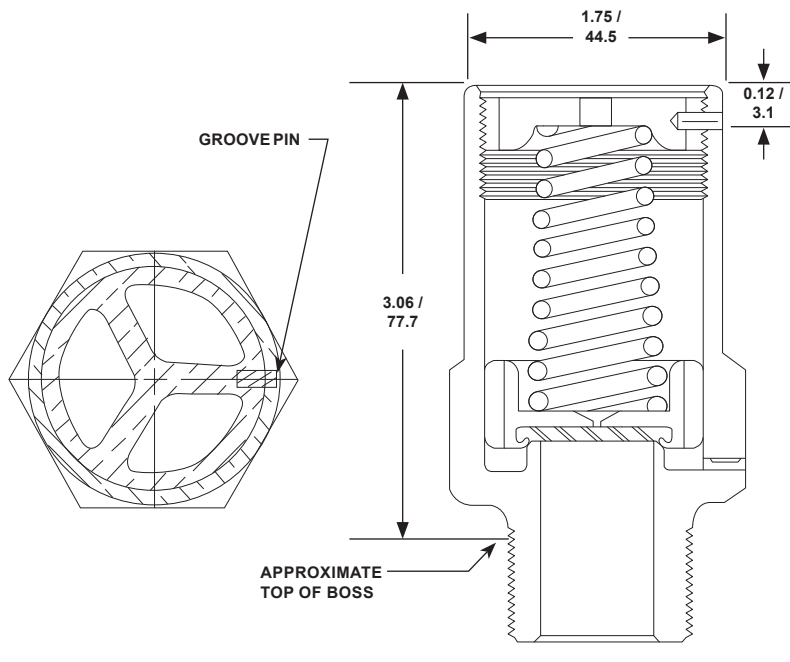

Figure 4. Dimensions

# H200 Series

---

 [Webadmin.Regulators@emerson.com](mailto:Webadmin.Regulators@emerson.com)

 [Fisher.com](http://Fisher.com)

 [Facebook.com/EmersonAutomationSolutions](https://Facebook.com/EmersonAutomationSolutions)

 [LinkedIn.com/company/emerson-automation-solutions](https://LinkedIn.com/company/emerson-automation-solutions)

 [Twitter.com/emr\\_automation](https://Twitter.com/emr_automation)

## Emerson Automation Solutions

### Americas

McKinney, Texas 75070 USA  
T +1 800 558 5853  
+1 972 548 3574

### Europe

Bologna 40013, Italy  
T +39 051 419 0611

### Asia Pacific

Singapore 128461, Singapore  
T +65 6777 8211

### Middle East and Africa

Dubai, United Arab Emirates  
T +971 4 811 8100

D100165X012 © 1979, 2019 Emerson Process Management Regulator Technologies, Inc. All rights reserved. 12/19.

The Emerson logo is a trademark and service mark of Emerson Electric Co. All other marks are the property of their prospective owners. Fisher™ is a mark owned by Fisher Controls International LLC, a business of Emerson Automation Solutions.

The contents of this publication are presented for informational purposes only, and while every effort has been made to ensure their accuracy, they are not to be construed as warranties or guarantees, express or implied, regarding the products or services described herein or their use or applicability. All sales are governed by our terms and conditions, which are available upon request. We reserve the right to modify or improve the designs or specifications of such products at any time without notice.

Emerson Process Management Regulator Technologies, Inc does not assume responsibility for the selection, use or maintenance of any product. Responsibility for proper selection, use and maintenance of any Emerson Process Management Regulator Technologies, Inc. product remains solely with the purchaser.

