



ENGLISH



**EVOLUTION IS
IN THE AIR**



ITALIAN PNEUMATIC COMPONENTS FOR INDUSTRIAL AUTOMATION

www.waircom-mbs.com





EVOLUTION IS IN THE AIR

**EVERY DAY COMES TO LIFE
OUR COMMITMENT TO OFFER
SERVICES AND SOLUTIONS
OF EXCELLENCE TO THE WORLD
OF AUTOMATION.**



60

YEARS

**HISTORY
IS IN THE AIR.**



1957 WAIRCOM IS

BECAUSE TO FLY IN THE FUTURE WE HAVE TO START FROM FAR AWAY.

In the time span of 60 years, Waircom consolidated its presence on the national and international market, constantly diversifying the product range, adapting to technological and market developments, consistently expanding its sales network. Steady growth that led Waircom to be among the leading Italian companies specialized in the production of pneumatic components for Industrial automation.

Our story begins in 1957 in Lombardy, one of the most historically important industrial areas of Europe. A region that has always had a strong commitment to the industry and automation, and who has infused Waircom of an entrepreneurial culture founded on innovation, research, commitment, with a constant focus on customer needs. An imprinting that has always led the company, now oriented to the new challenges that the future proposes.



P N E U M A T I C 2017



**A QUALITY
OF ITALIAN
GENERATION.**

**Italian brand
recognized
in the world.**

**Convenient
quality/price ratio.**

**QMS conforms to
the ISO 9001 standard.**

BECAUSE RELIABILITY AND SAFETY PUSH UP YOUR PROJECTS.

In Waircom the word "Quality" has many values: means technological reliability, security, scrupulous attention in production cycles as well as a meticulous testing of each product. It also means integrated management of the production process, flexibility, optimized quality / price ratio, coordination between departments, ability to cope quickly with any urgency or special request of customers. However, speed is nothing without attention.

Waircom technology has the appropriate tools to ensure a level of precision without comparisons. CNC production machine and testing devices, machining centers, rotary transfer machines, profile projector, machines for surface treatment thickness and for the hardness control. High technology and utmost care in certification witness our unwavering commitment to the highest quality.



**Testing 100%
of the products.**

**100% of the
production
manufactured in Italy.**

**R&D and Assembly
100% Italian.**

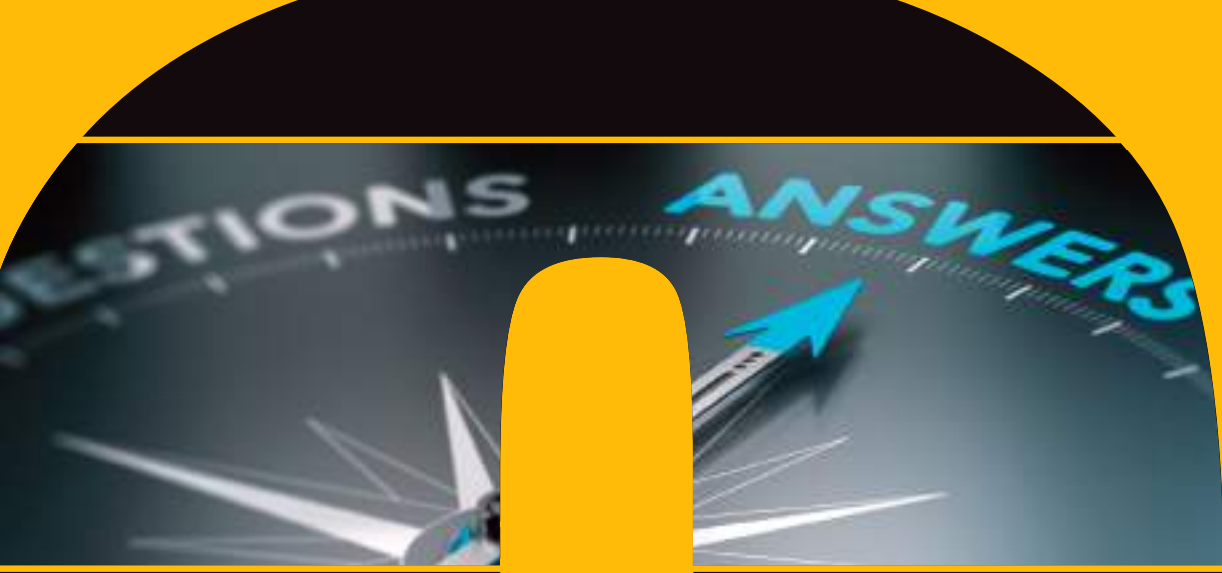

**A CONSULTANCY
READY
TO LISTEN TO YOU.**

**Customized
special
projects.**

**Management
& manufacturing
flexibility.**

BECAUSE ARE THE SMALL DETAILS THAT MAKE THE GREAT IDEAS FLYING.

“Talking is the way to express himself to others. Listening is the way to accommodate others in himself “: so says an old Taoist text. Listening means understanding, welcome the other instances; and that is what Waircom team undertakes to do every time we have to meet the demands of customers or suppliers. For this Waircom is among the best companies on the market capable of managing and designing custom projects based on the special needs of each client.

Waircom technicians and designers are young professionalism and dynamic people with great technical and commercial background, and able to take care of every detail throughout the whole consulting process (production and management), with a really fast & effective Time to Market, with great advantages in terms of efficiency, flexibility and accuracy in response to customer needs.



**Fast & effective
Time to Market.**

**Technical/sales assistance
& specialized follow-up.**

AN ACCURATE & FLEXIBLE LOGISTICS.



**Constant
control of the
logistical network.**

**Reduced
lead time.**

BECAUSE YOUR PRODUCTION PROCESS FLOWS WITHOUT INTERRUPTIONS.

Waircom can count on a network of distributors, resellers and agents extended throughout the national territory and in many foreign countries. A flexible & interconnected network designed to make the connection among our company and the end-users as fluid as possible.

Our logistics network allows us to have a short lead-time, due to a large stock availability of all the standard products, combined with a careful and rational management and inventory planning and a reduced Time to Market for products created "ad hoc", thanks to a perfect coordination between the design, production and commercial areas.



**Great availability
of the standard
items in stock.**

**Planning &
inventory
management.**



**A
COMPREHENSIVE
RESEARCH.**

Planning.

Screening.

Test.

BECAUSE WE ARE PART OF THE ITALIAN INNOVATION THAT CAN ENHANCE THE WORLD.

Research and innovation are distinctive features of all Italian companies able to impose themselves on the international scenario, and Waircom is one of them. The latest generation of software for 2D and 3D designing are the tools that allow us to provide tailored solutions to specific market needs. Each application context is a challenge for us, which we accept with the certainty of being able to always live up to expectations.

A constant update on new technologies and design development systems, a great curiosity about all the news and an openness to new market developments make us a company ready to accept all inputs coming from possible future scenarios, which can improve our ability to act on the market.

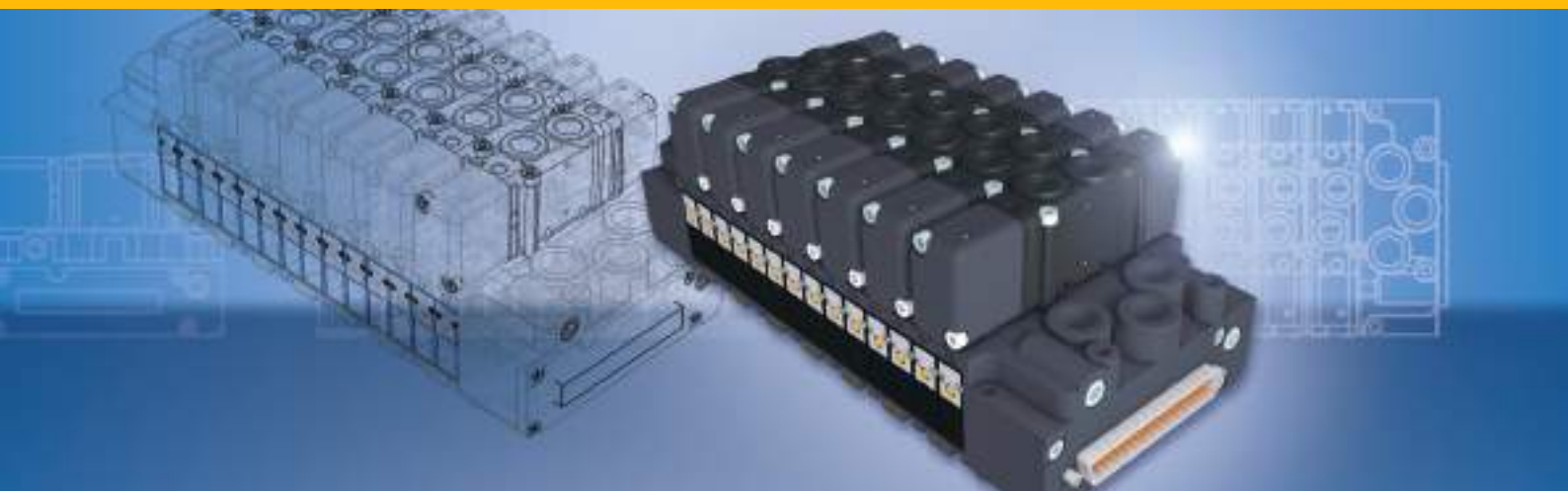

Feasibility.

Development.

Engineering.



A SUCCESS OF INTERNATIONAL CONCERN.

Waircom is a company focused on expanding its market beyond national borders. For a long time now we have developed a sales network almost all over the world, to bring our vision of a modern and active company as far as we can.

This is possible thanks to the qualities that define us as a typical Italian company: creativity, flexibility, problem solving attitude, high human potential & outstanding interpersonal skills of the whole Waircom team.

INTERNATIONAL SALES NETWORK

AUSTRALIA	IRAN	SINGAPORE
CANADA	JAPAN	SLOVENIA
CHINA	JORDAN	SPAIN
COLOMBIA	KUWAIT	SOUTH AFRICA
CÔTE D'IVOIRE	MALAYSIA	SYRIA
CYPRUS	MOROCCO	THAILAND
CZECH REPUBLIC	NETHERLAND	TUNISIA
DENMARK	PAKISTAN	TURKEY
EGYPT	POLAND	VIETNAM
FRANCE	PORTUGAL	UNITED ARAB EMIRATES
GERMANY	ROMANIA	UNITED KINGDOM
GREECE	SAUDI ARABIA	ZIMBABWE

ITALIAN SALES NETWORK



WAIRCOM M.B.S. S.p.A. - SALES OFFICE

Via Piemonte 13/15 - 20070 Vizzolo Predabissi (MILAN) - ITALY

Tel: +39 02 98230821 - Fax: +39 02 98231854

www.waircom-mbs.com - info@waircom-mbs.com

DISTRIBUTORS AND RETAILERS

ABRUZZO

A.F.I. S.n.c.

Via Penne, 10 - 66013 CHIETI SCALO (CH)
Tel: 0871/561812 Fax: 0871/552290

DI EMIDIO DOMENICO S.r.l.

Via G. di Vittorio - Villa Pavone - 64100 TERAMO
Tel: 0861/210242 Fax: 0861/210243

DI EMIDIO S.r.l.

Zona Ind.le Colleranesco - 64020 GIULIANOVA (TE)
Tel: 085/8004550/8002624 Fax: 085/8004879

ICAM COMMERCIALE S.a.s.

S.S. 16 Nord KM 509 - 66054 Vasto (CH)
Tel: 0873/3711306 - Fax: 0873/3711307

SERAFINI MARIO S.r.l.

Via Saletti - Zona Commerciale - 66041 PIAZZANO DI ATESSA (CH)
Tel: 0872/897029 Fax: 0872/888923

BASILICATA

GIOVANNI VENERI & C. S.r.l.

Via della Fisica, 26 - 85100 POTENZA
Tel: 0971/472210-11 Fax: 0971/472212

CALABRIA

FIM S.a.s.

Viale del Lavoro, 79 - 87012 CASTROVILLARI (CS)
Tel: 0981/480102 Fax: 0981/483100

FORNITURE INDUSTRIALI LAVILLA GIOVANNI

Via Carrera, 49/a - 89122 REGGIO CALABRIA
Tel: 0965/650630 Fax: 0965/650630

CAMPANIA

AR.TEC.SUD S.r.l.

Via Francesco Tedesco, 558 - 83100 AVELLINO
Tel: 0825/622721 - Fax: 0825/628234

CASA DEL CUSCINETTO di R.G. PAPPALARDO & C. Sas

Via Wenner, 77 - Zona Industriale - 84132 FUORNI (SA)
Tel: 089/771177 - Fax: 089/771131

CAVA CUSCINETTI S.r.l.

Via G.Palumbo, 35/37 - 84013 CAVA DEI TIRRENI (SA)
Tel: 089/343587 - Fax: 089/9437996

FIA S.a.s. DI PERROTTA GIOVANNI & C.

Via XX Settembre, 94 - 81020 SAN NICOLA LA STRADA (CE)
Tel: 0823/421343 - Fax: 0823/421343

OLEODINAMICA PARTENOPEA S.a.s.

Via Martiri Atellani, 194 - 81030 ORTA DI ATELLA (CE)
Tel: 081/5022646 Fax: 081/5022646

PHI-AIR S.a.s.

Via Nazionale delle Puglie, 176/A - 80026 CASORIA (NA)
Tel e Fax: 081/6583599-600

TECNOLOGIA OLEODINAMICA S.r.l.

Via Variante 7 bis, 93 - 80035 NOLA (NA)
Tel: 081/8235314 - Fax: 081/3145913

EMILIA ROMAGNA

ACERO S.r.l.

Via A. Calzi, 30 - 48018 FAENZA (RA)
Tel: 0546/620731 Fax: 0546/621450

AIR MECCANICA S.n.c.

Via Coriano, 58 - Blocco n. 32/E - 47924 RIMINI
Tel: 0541/387704-302721 Fax: 0541/382510

BIANCHI INDUSTRIAL S.p.A

Via Giovanni Elkan, 5 - 40132 BOLOGNA
Tel: 051/414849 - Fax: 051/729301

CCRE S.p.A

Via T. Galimberti, 1 - 42124 REGGIO EMILIA
Tel: 0522/701211 - Fax: 0522/701250

CCRE S.p.A Filiale di Piacenza

Via del Commercio, 14/16 - 29122 PIACENZA
Tel: 0523/576011 - Fax: 0523/593272

CCRE S.p.A Filiale di Ferrara

Via V. Woolf, 20 - 44124 FERRARA
Tel: 0532/67130 - Fax: 0532/748926

EMILTECNICA S.r.l.

Via Emilia Est 1058/A - 41126 MODENA
Tel: 059/282640 - Fax: 059/282763

F.M.I. FRANCESCHI S.r.l.

Via Baganzola, 28/A - 43126 PARMA
Tel: 0521/992200 - Fax: 0521/987303

LIGURIA

BM SERVICE S.r.l.

Via Bombrini, 26 - ROSSO - 16149 GENOVA
Tel: 010/6422287 Fax: 010/6422287

LAZIO

CASA DEL FRENO F.LLI PISTILLI S.n.c.

Via Epitaffio, 128 - 04100 LATINA
Tel: 0773/663860 Fax: 0773/663528

SLM S.r.l.

Via Cerro Antico - 03043 CASSINO (FR)
Tel: 0776/300702 Fax: 0776/370247

F.I.A.M. S.a.s DI ELIA D'AGUANO & C.

Via G. Roncacci 1/D - 00067 Morlupo (RM)
Tel: 06/9070681 - Fax: 06/90190989

TSR S.r.l OLEODINAMICA PNEUMATICA

Via Solfegna Cantoni Zona Ind.le - 03043 Cassino (FR)
Tel: 0776/398066 - Fax: 0776/398095

LOMBARDIA

ARIA COMPRESA S.r.l.

Corso Martiri della Liberazione, 40 - 23900 LECCO
Tel: 0341/282785 Fax: 0341/285273

ATEMI S.r.l.

Via Monte Bianco, 2 - 20095 CUSANO MILANINO (MI)
Tel: 02/6198256 Fax: 02/6133611

BIGNARDI DI BIGNARDI A.e C. S.a.s.

Via del Sebino, 44/46 - 25126 BRESCIA
Tel: 030/294169 Fax: 030/3771178

CCRE S.p.A Filiale di Codogno

Via T. Ercoli, 3 - 26845 CODOGNO (LO)
Tel: 0377/30043 - Fax: 0377/36730

CCRE S.p.A Filiale di Crema

Via Capergnanica, 8/A - 26013 CREMA (CR)
Tel: 0373/430810 - Fax: 0373/430814

EREDI DI M. FARINA S.r.l.

C.so Sempione, 45 - 20025 LEGNANO (MI)
Tel: 0331/544311 Fax: 0331/453690

EUROPAIR S.r.l.

Via Benvenuto Cellini, 13 - 20852 VILLASANTA (MB)
Tel: 039/2620802 - Fax: 039/2620890

FLUTEK S.r.l.

Via Raso, 5 - 25036 PALAZZOLO SULL'OGLIO (BS)
Tel: 030/7402960 Fax: 030/7402961

MICAR S.r.l.

Via Rosso di S. Secondo, 15 - 20134 MILANO
Tel: 02/7491091 Fax: 02/70126372

UTRES S.r.l.

Via Galvani, 1/A - 46029 SUZZARA (MN)
Tel: 0376/521321 - Fax: 0376/521936

VERZOLLA S.a.s. di MAMBRETTI PAOLO PRIMO

Via Brembo, 13/15 - 20052 MONZA (MI)
Tel: 039/21661 Fax: 039/2103010



MARCHE

SARO AUTOMAZIONI S.r.l.

Via Vincenzo Breda, Zona Ind.le "A"
62012 CIVITANOVA MARCHE (MC)
Tel: 0733/897795 Fax: 0733/897887

BRAMMER ITALIA S.r.l

Via Pasubio, 106 - 63039 SAN BENEDETTO DEL TRONTO (AP)
Tel: 0735/76171 - Fax: 0735/655266

TORRESI RAFFAELE S.r.l

Via Sandro Pertini, 51 zona ind.le "A"
62012 CIVITANOVA MARCHE (MC)
Tel: 0733/801120 - Fax: 0733/801130

PIEMONTE

ARCISA S.r.l.

Via Valpellece, 14 - 10060 SAN SECONDO DI PINEROLO (TO)
Tel: 0121/500445 Fax: 0121/500370

FIMU S.r.l

Via Pavia 9 int. 16 - 10098 Rivoli (TO)
Tel: 011/3910571 - Fax: 011/3486180

CENTRO CANAVESANO CUSCINETTI S.a.s.

C.so Re Arduino, 9/B - 10086 RIVAROLO CANAVESE (TO)
Tel: 0124/26324 Fax: 0124/25762

NUOVA O.P.E. S.r.l.

Via Molino Roero, 6 - 12020 MADONNA DELL'OLMO (CN)
Tel: 0171/411977 Fax: 0171/411421

PUGLIA E BASILICATA

ATIM S.r.l

Via Monte Pollino, 23 - 70022 ALTAMURA (BA)
Tel: 080/3115257 - Fax 080/3143414

ATOM S.r.l

Via G. Capruzzi, 266 BC - 70124 BARI
Tel: 080/5428971 - Fax: 080/5428971

CENTRO CUSCINETTI FOGGIA S.n.c

Via Fortore, 9b/19 - 71121 FOGGIA
Tel: 0881/777680 - Fax 0881/777680

TECNOFER S.r.l

Traversa di via della Tramvia, 2/2 - 76121 BARLETTA (BT)
Tel: 0883/346744 - Fax: 0883/337150

TECHNO FORNITURE S.r.l.s.

Via Udine, 47 - 72023 MESANGE (BR)
Tel/Fax: 0831/857666

SARDEGNA

IDROP S.a.s

Viale Elmas 142 - 09122 Cagliari
Tel: 070/240048 - Fax: 070/241172

SICILIA

CENTRO OLEODINAMICA S.r.l.

Via zia Lisa, 253 - 95121 CATANIA
Tel: 095/578514 Fax: 095/575826

F.LLI FIDERIO S.n.c

Via del campo sportivo, 25 - 97015 MODICA (RG)
Tel: 0932/763014 - Fax: 0932/763014

MALTESE MAURIZIO

Via Sellinunte, 2 - 91026 MAZARA DEL VALLO (TP)
Tel: 0923/942665 Fax: 0923/942665

SOMET S.r.l

C.da Vignarelli sn - Zona Art.le - 96014 FLORIDIA (SR)
Tel: 0931/941910 - Fax: 0931/544645

TOSCANA

ATI DI MORGANTI S.r.l

Via Pistoiese, 219 ang. Via Castagnoli, 1 - 59100 PRATO
Tel: 0574/6961 - Fax: 0574/400648

FILIALE DI MACROLOTTO

Via Aldo Moro, 28 - 59100 MACROLOTTO (PO)
Tel: 0574/643438 - Fax: 0574/644555

FILIALE DI VAIANO

Via Val di Bisenzio, 222 - 5921 VAIANO (PO)
Tel: 0574/988350 - Fax: 0574/989576

FILIALE DI MONTEMURLO

Via Palarciano, 57 - 59013 MONTEMURLO (PO)
Tel: 0574/680438 - Fax: 0574/790996

FILIALE DI CALENZANO

Via di Le Prata, 33 - 50041 CALENZANO (FI)
Tel: 055/8826501 - Fax: 055/8826513

FILIALE DI PISTOIA

Via Botta, 93 (Loc. S. Agostino) - 51100 PISTOIA
Tel: 0573/532614 - Fax: 0573/533069

FILIALE DI MASSA

Via Dorsale Parco Produttivo Apuania lotto, 18 - 54100 MASSA (MS)
Tel: 0585/793615 - Fax: 0585/791158

FILIALE DI CAPANNORI

Viale Europa, 2 - 55012 CAPANNORI (LU)
Tel: 0583/469760 - Fax: 0583/469656

UMBRIA

ATI DI MORGANTI S.r.l

Via Yuri Gagarin, 1 - 06073 ELLERA (PG)
Tel: 075/5172690 - Fax: 075/5173208

SEA S.r.l

Via Pietrarossa, 1/1 - 06039 TREVÌ FRAZ. BORGO TREVÌ (PG)
Tel: 0742/386900 - Fax: 0742/381296

VENETO E FRIULI VENEZIA GIULIA

FILIALE COMMERCIALE: WAIRFLEX S.a.s.

Viale Italia, 224 - 31015 CONEGLIANO (TV)
Tel: 0438/412552 Fax: 0438/418003

EFFEGI FORNITURE S.r.l

Loc. Villabella, 53 - 37047 SAN BONIFACIO (VR)
Tel: 045/7613144 - Fax: 045/6133875

EMPORIO RICAMBI ROSSI S.p.A.

Via Este, 40/2 - 33100 UDINE
Tel: 0432/600114 Fax: 0432/523021

FIZNER AUTOMAZIONE S.a.s.

Via M. Giuliani Dalmati, 13 - 35129 PADOVA
Tel: 049/772700 Fax: 049/8072401

MARCANZIN & MEROTTO S.r.l.

V.le della Repubblica, 236 - 31100 TREVISO
Tel: 0422/304111 Fax: 0422/306557

NOVELLO S.r.l.

Cà Marcello, 73 - 30172 MESTRE (VE)
Tel: 041/5311633 Fax: 041/5310125

OLEOMEC S.r.l.

Via dell'Artigianato, 8 - 32100 BELLUNO (TV)
Tel: 0437/931252 Fax: 0437/33230

O.P.S. S.r.l.

Via Travnik, 18/2 - 34147 S. DORLIGO DELLA VALLE (TS)
Tel: 040/383808 Fax: 040/382555

PNEUMAC S.r.l.

Viale Italia, 254 - 31015 CONEGLIANO (TV)
Tel: 0438/35005 Fax: 0438/410211

SO.CI.MA S.r.l.

Via Lago Maggiore, 8 - 36077 ALTAVILLA VICENTINA (VI)
Tel: 0444/370744 Fax: 0444/370748



**GENERAL CATALOGUE
INDUSTRIAL PNEUMATIC COMPONENTS**



CONTENTS

Chapter 0

TECHNICAL INFORMATION

Page 0.1



Chapter 1

CYLINDERS

Page 1.0



Chapter 2

VALVES PILOT AND SOLENOID ACTUATED

Page 2.1



Chapter 3

VALVES MANUALLY AND MECHANICALLY ACTUATED AND COMPLEMENTARY VALVES

Page 3.1



Chapter 4

AIR TREATMENT

Page 4.1



Chapter 5

FITTINGS AND TUBES

Page 5.1

The company reserves the right to amend without notice the specifications given in this document



Fluid	page	0.2
Pressure	page	0.3
Rated flow rate	page	0.4
Flow rate calculations	page	0.4
Relation between Kv, kv, Cv, S, de²	page	0.4
Specific weight	page	0.5
Steam	page	0.5
Seal material	page	0.6
Chemical compatibility table	page	0.6
Protection class for coils with connectors	page	0.7
Graphic symbols	page	0.8
Comparison and designation of connection	page	0.11
Multiples and sub-multiples	page	0.11
Consumption of air table	page	0.11
Peak load and theoretical forces	page	0.12
Cushioning diagram	page	0.12
Springs theoretical tractive force	page	0.13
Conversions tables	page	0.14
Threads comparison table	page	0.15
General technical data for cylinders	page	0.16
Insulation class - coils	page	0.16
Continuous service “ED” - coils	page	0.16
ATEX directive	page	0.17
Mixed equipment (electrical and mechanical)	page	0.17
Zones classification	page	0.18
Zones classification according to the 2014/34/EU directive	page	0.18
Correspondences between zones and categories according to the 2014/34/EU directive	page	0.18
Example of marking for mechanical devices (without electrical components)	page	0.19
Example of marking for mechanical and electrical devices	page	0.19
Protection methods and reference standards	page	0.20

Technical information

0

FLUID

Most of WAIRCOM M.B.S. products must be fed with lubricated or unlubricated compressed filtered air.

FLUID COMPATIBILITY

Before realising the plant it's a good rule to check the chemical compatibility of used oils in the air compressor, oils used in the lubricator, if present, and oils or cutting fluids used on the machines downstream of the plant that may enter in the cylinders and go back to the valves. If these oils that come in contact with the fluid are not compatible with elastomer seals present in our products, they can reinflate or crack them causing malfunctions. For more information about the compatibility between the different materials see table on page 0.6

FILTERS

It's important that input fluid to a pneumatic plant is always filtered to remove solid impurities, condensation or any traces of substances which are not compatible with elastomers coming from devices placed upstream of the plant. Waircom always suggest to filter incoming air with filters with a void fraction of at least 40 μ m. The condensate drainage system accumulated in the filter bowl can be manual, semi-automatic or automatic and it is set up of a cock situated on the bottom of the bowl.

LUBRICATORS

A correct lubrication keeps the performance of the components in the course of time. The absence of lubrication leaves space to the only initial lubrication that each component receives during the assembly. Lubrication, when applied, must be maintained, in its absence the seals of the components may go bad jeopardizing the operation. Waircom, for proper lubrication of the components, advises to use 1 drop of "WAIRSOL" grease class ISO22 every 300/500 NI, a lubricant especially studied for pneumatic plants compatible with all materials used in both our components and the equipment usually used in pneumatic

AIR PURITY CLASS

ISO8573-1 standard summarizes what is described above by defining the degree of purity of the air in terms of solid particles, moisture, and oil concentration.

FLUID CHARACTERISTICS

Fluid temperature: from -10 to + 60 ° depending on the component
Environment temperature: from -20 to + 80 ° depending on the component
Air filtering according to ISO 8573-1: not superior to 5/5/4 (see table)
Lubrication: not necessary, in case to use WAIRSOL grease ISO 22 and don't stop it
Oil quantity: a drop every 300 ÷ 500 liters of air.

AIR PURITY CLASSES			
Class	Solid bodies max. dimensions of the particles	Water content dew point	Oil quantity max. concentration
1	0,1 μ	-70 °C	0,01 mg/m ³
2	1 μ	-40 °C	0,1 mg/m ³
3	5 μ	-20 °C	1 mg/m ³
4	15 μ	+3 °C	5 mg/m ³
5	40 μ	+7 °C	25 mg/m ³

PRESSURE

DEFINITION OF PRESSURE

It is the ratio between a force and the surface on which it acts; it is dimensionally expressed in force units per surface units.

$$P(\text{Pa}) = F(\text{N}) / S(\text{m}^2)$$

ATMOSPHERIC PRESSURE

It is the pressure exerted on a surface of 1 cm² at sea level, at a temperature of 20 °C and with a relative humidity of 65%; it is equivalent to a column of water of 10,33 m or to 760 mmHg.

GAUGE PRESSURE

It is the differential pressure of a fluid above and below the atmospheric pressure normally read on the pressure gauges.

ABSOLUTE PRESSURE

It is the pressure of a fluid respect to the absolute vacuum and it is obtainable adding the atmospheric pressure to the gauge one.

UPSTREAM PRESSURE

Pressure of the compressed air at the inlet of the pneumatic component.

DOWNSTREAM PRESSURE

Pressure of the compressed air at the outlet of the pneumatic component.

DIFFERENTIAL PRESSURE (P)

It is the difference between upstream and downstream pressure.

BOYLE-MARIOTTE'S LAW

The volume of a closed quantity of gas with constant temperature is inversely proportional to the absolute pressure, this means that for a given quantity of gas the product between the absolute pressure and the volume is a constant value:

$$P_1 \cdot V_1 = P_2 \cdot V_2 = \text{costante}$$

GAY - LUSSAC'S LAW

The volume of a quantity of gas with constant pressure is proportional to its temperature:

$$V_1 / V_2 = T_1 / T_2$$

or even, with constant volume, the pressure of a quantity of gas is proportional to its temperature.

$$P_1 / P_2 = T_1 / T_2$$

Then we obtain the General Equation of Gases:

$$P \cdot V = n \cdot R \cdot T$$

where:

P = pressure (atm)

V = volume (NI)

n = gram molecules of gas contained in the volume (mol)

R = perfect gas constant (0,0821 NI · atm · K⁻¹ · mol⁻¹)

T = absolute temperature in Kelvin (273 K = 0 °C)

NORMAL CONDITIONS OF AIR

In the design of industrial pneumatic circuits are employed measures that refer to the "Normal conditions of air".

As "normal cubic meter of air" (1Nm³) we refer to 1 m³ of air at a temperature of 273 K (0 °C) and at a pressure of 1,0013 bar (pressure of the normal air at the sea level): 1 Nm³ = 1000 NI.

Technical information

0 RATED FLOW RATE

It is the volume of fluid passing through a given section of measurement in a unit of time with an upstream gauge pressure $P_1=6$ bar (7 absolute bar) and with a pressure drop $P=1$ bar (thus means a downstream gauge pressure $P_2=5$ bar, 6 absolute bar) with a fluid temperature of $+20$ °C. The rated flow rate, generally expressed in normal liters per minute (Nl/m), can give some indications on the performances of the valves if the working conditions are the ones just described.

Herebelow are the circuits used in our company to test the flow rate measurements of products in according to the UNI ISO 6358 standard.



Testing circuit for components with input/output connection.

- A – Filter and supply unit
- B – Adjustable pressure regulator
- C – Shut-off valve
- D – Tube for temperature measurement
- E – Device for the measure of temperature
- F – Tube for upstream pressure measurement
- G – Component on trial
- H – Tube for downstream pressure measurement
- I – Device for the measure of upstream pressure
- J – Device for the measure of differential pressure
- K – Flow regulator valve
- L – Device for the measure of flow rate

FLOW CALCULATION

To determine the flow of the liquids that pass through the solenoid valves of “W” Series, we use the formula shown below, in which the hydraulic coefficient K_v , the fluid density and differential pressure are used. The hydraulic coefficient is determined in an experimental way as indicated by VDE 2174 standards and it represents the flow of water in m^3/h which runs through the solenoid valve with a differential pressure of 1 bar and a temperature between 5 °C and 40 °C.

Liquids

$$Q = K_v \sqrt{\frac{\Delta p}{\rho}}$$

This calculation method provides approximate data in case of compressed air, however, the transfer from the hydraulic case to the air one can be done considering the density variation and with the hypothesis that the passage of air will produce the same effects of water, with same losses and contractions flow.

In subsonic regime $P_2 > \frac{P_1}{2}$ or $\Delta p = \Delta p < \frac{P_1}{2}$

Air

$$Q_N = 28,6 \cdot K_v \cdot \sqrt{P_2 \Delta p} \cdot \sqrt{\frac{T_N}{T_1}}$$

Gas

$$Q_N = 514 \cdot K_v \sqrt{\frac{\Delta p \times P_2}{\rho_n \times (273 + T_1)}}$$

Vapors

$$G = 31,6 \cdot K_v \sqrt{\frac{\Delta p}{V_2}}$$

In sonic regime $P_2 > \frac{P_1}{2}$ or $\Delta p = \Delta p > \frac{P_1}{2}$

$$Q_N = 14,3 \cdot K_v \cdot P_1 \cdot \sqrt{\frac{T_N}{T_1}}$$

$$Q_N = 257 \cdot K_v \frac{P_1}{\sqrt{\rho_n \times (273 + T_1)}}$$

$$G = 31,6 \cdot K_v \sqrt{\frac{P_1}{V_1}}$$

- $K_v = m^3/h \left(\frac{kg}{dm^3 \cdot bar} \right)^{1/2}$ Hydraulic coefficient
- $Q = m^3/h$ Flow
- $Q_N = m^3/n/h$ Normal flow (20 °C 760 mm Hg)
- $P_1 = bar$ Absolute inlet pressure (gauge pressure +1)
- $P_2 = bar$ Absolute outlet pressure (gauge pressure +1)
- $\Delta p = bar$ Pressure drop (pressure differential between the inlet pressure and the outlet pressure)
- $\rho = Kg/dm^3$ Relative gravity than water (water at 4 °C = 1)
- $\rho_n = Kg/dm^3$ Normal relative density than air
- $G = Kg/h$ Mass
- $T_1 = K$ Absolute input temperature (for converting °C in K = > 273+°C)
- $T_N = 293 K$ Absolute temperature reference
- $V_1 = m^3/Kg$ Specific input volume
- $V_2 = m^3/Kg$ Volume specifico in uscita alla pressione P_2 and the temperature t

RELATIONS BETWEEN K_v , k_v , C_v , Sp , dp^2

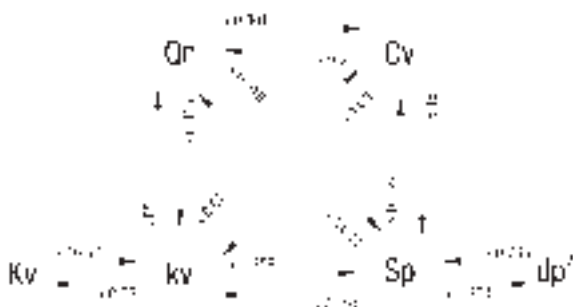

Qn	Nominal flow	Nl/min
kv		l/min
Kv	Hydraulic coefficient	m ³ /h
Cv		Usa Gallons/min
Sp	Nominal passing section	mm ²
dp²	Nominal passing diameter*	mm ²

* to derive the diameter dp (mm) perform the square root of dp^2

SPECIFIC WEIGHT

Liquid	Temp. (°C)	Specific weight (Kg/dm ³)	Gases and vapors	Specific weight	
				Relative density to air	(Kg/dm ³)
Acetone	25	0,787	Acetylene (ethyme)	0,90	1,085
Acetylene liquid	70 °F	0,38	Air*	1	1,205
Alcohol, ethyl (ethanol)	25	0,787	Alcohol vapor	1,6	1,929
Alcohol, methyl (methanol)	25	0,791	Ammonia	0,59	0,711
Alcohol, propyl	25	0,802	Argon	1,38	1,663
Ammonia (aqua)	25	0,826	Benzene	2,70	3,249
Aniline	25	1,022	Butane	2,01	2,417
Benzene	25	0,876	Isobutene	1,94	2,338
Benzil	25	1,084	Carbon dioxide	1,52	1,830
Bromine	25	3,12	Carbon monoxide	0,97	1,165
Butane, liquid	25	0,601	Chlorine	2,49	2,996
Caustic soda 9% - NaOH	15	1,1	Cyclobutane	1,94	2,335
Caustic soda 18% - NaOH	15	1,2	Cyclopentane	2,42	2,919
Caustic soda 27% - NaOH	15	1,3	Cyclopropane	1,45	1,748
Caustic soda 47% - NaOH	15	1,5	Deuterium	0,07	0,084
Chloroform	25	1,469	Ethane	1,04	1,251
Ethane	- 89	0,572	Ether vapor	2,59	3,116
Ether	25	0,716	Ethel Chloride	2,23	2,687
Ethylene glycol	25	1,1	Ethylene (Ethene)	0,97	1,167
Formaldehyde	45	0,815	Flourine	1,31	1,579
Freon R-11	25	1,48	Helium	0,14	0,166
Freon R-12	25	1,315	Heptanes	3,46	4,168
Freon R-22	25	1,197	Hexane	2,97	3,582
Fuel oil	60° F	0,893	Hydrogen	0,07	0,084
Gasoline, Vehicle	60 °F	0,739	Hydrogen chloride	1,27	1,528
Hydrochloric acid 10%	15	1,05	Hydrogen sulfide	1,18	1,417
Hydrochloric acid 20%	15	1,1	Hydrofluoric acid	2,37	2,856
Hydrochloric acid 30%	15	1,15	Hydrochloric acid	1,26	1,520
Hydrochloric acid 40%	15	1,2	luminanting gas	0,4	0,482
Kerosene	60 °F	0,82	Isobutane	2,01	2,442
Mercury	25	13,633	Isopentane	2,48	2,988
Milk	15	1,035	Mercury vapor	6,94	8,363
Naphta	15	0,667	Methane	0,55	0,667
Nitric acid 17%	15	1,1	Natural gas (typical)	0,7 - 0,5	0,844 - 0,723
Nitric acid 25%	15	1,15	Neon	0,70	0,840
Nitric acid 47%	15	1,3	Nitrogen	0,97	1,165
Nitric acid 94%	15	1,5	Nitrous oxide	1,53	1,844
Octane	25	0,701	Octane	3,94	4,753
Olive oil	15	0,703	Oxygen	1,1	1,331
Oxygen	-183	1,14	Ozone	1,66	2,000
Potassium Hydroxide 21%	15	1,2	Pentane	2,49	2,997
Potassium Hydroxide 49%	15	1,5	Propane	1,52	1,834
Propane	25	0,495	Propene (Propylene)	1,45	1,834
Sulphuric acid 27%	15	1,2	R-12	4,17	5,030
Sulphuric acid 50%	15	1,4	R-134a	3,52	4,244
Sulphuric acid 87%	15	1,8	Sulfur Dioxide	2,26	2,728
Sulphuric acid, pure	15	1,89	Water vapor	0,62	0,749
Turpentine	25	0,871	Xenon	4,53	5,459
Water, pure	4	1			
Water, sea	77° F	1,025			

*NTP - Normal Temperature and Pressure - is defined as air at 20° C and 1 atm. Specific gravity is the ratio between the density (mass per unit volume) of the actual gas and the density of air, specific gravity has no dimension. The density of air at NTP is 1.205 Kg/dm³.

STEAM

Relative pressure (bar)	Absolute pressure (bar)	Temperature (°C)	Steam specific volume (m ³ /kg)
-	0,050	32,88	28,192
-	0,500	81,33	3,240
0,00	1,013	10,00	1,673
0,10	1,113	102,66	1,533
0,20	1,213	105,10	1,414
0,35	1,363	108,50	1,268
0,50	1,513	111,61	1,149
0,70	1,713	115,40	1,024
1,00	2,013	120,42	0,881
1,50	2,513	127,62	0,714
2,00	3,013	133,69	0,603
2,50	3,513	139,02	0,522
3,00	4,013	143,75	0,461
3,50	4,513	148,02	0,413
4,00	5,013	151,96	0,374
4,50	5,513	155,55	0,342
5,00	6,013	158,92	0,315
6,00	7,013	165,04	0,272
7,00	8,013	170,50	0,240
8,00	9,013	175,43	0,215
9,00	10,013	179,97	0,194
10,00	11,013	184,13	0,177

Technical information

0

SEAL MATERIALS

DESIGNATION	TYPICAL APPLICATION
NBR (Acrylic-nitrile-butadylene)	Water with a max temperature 70 °C, air with a max temperature 90 °C. Mineral oils and their derivatives, hydrocarbons, methane, ethane, propane, butane, kerosene oil, fuel oil.
EPDM* (Ethylene-propylene-dylene)	Hot water and steam. Detergents. Potassium and sodic solutions. Hydraulic fluids. Polarised solvents. Skydrol 500 e 700. Up to 140 °C
FPM (Fluorocarbon)	For general use up to 130 °C.
PTFE (Polytetrafluorethylene)	For general use up to 160 °C.

*Warning: not to be used with mineral oils and grease

CHEMICAL COMPATIBILITY TABLE

MEDIA	Brass	Stainless Steel	NBR	EPDM	FPM	PTFE
Acetone	●	●	-	●	-	●
Acetylene	●	●	-	●	●	●
Argon hold	●	●	-	●	●	●
Benzol	●	●	-	-	-	●
Butane	●	●	-	-	●	●
Calcium monoxide	●	●	●	●	●	●
Carbon dioxide (liquid)	-	●	-	-	-	●
Carbon disulphide	●	●	-	-	-	●
Chloroform	●	●	-	-	-	●
De-ionised water	-	●	●	●	●	●
De-meniralsed water	-	●	●	●	●	●
Dry carbon dioxide (gas)	●	●	●	●	●	●
Ethane	●	●	●	-	●	●
Ethanol	●	●	-	-	-	●
Ethyl acetate	●	●	-	-	-	●
Ethyl chloride	●	●	●	●	●	●
Ethylene glycol	●	●	●	●	●	●
Formaldehyde	●	●	●	●	●	●
Freon	●	●	-	-	-	●
Fuel oil	●	●	●	-	●	●
Glycerine	●	●	●	-	●	●
Hard water	●	●	●	●	●	●
Helium	●	●	●	-	●	●
Heptane	●	●	●	-	●	●
Hexane	●	●	●	-	●	●
Hot water <75 °C	●	●	●	●	●	●
Hot water and steam < 140 °C	●	●	-	●	-	●
Hydrogen	●	●	-	-	●	●
Hydrogen dioxide	-	●	-	-	●	●
Isobutane	●	●	●	-	●	●
Isopentane	●	●	●	-	●	●
Methane	●	●	●	-	●	●
Methanol	●	●	-	●	-	●
Methyl chloride	●	●	-	-	-	●
Mineral oil	●	●	●	-	●	●
Natural gas	●	●	●	-	●	●
Neon	●	●	●	-	●	●
Nitrobenzene	●	●	-	-	-	●
Nitrogen	●	●	●	●	●	●
Oxygen	●	●	●	-	●	●
Pentane	●	●	●	●	●	●
Petrol	●	●	-	-	●	●
Propane-n	●	●	●	-	●	●
Soapy water	●	●	●	-	●	●
Toluene	●	●	-	-	●	●
Trichlorethylene dry	●	●	-	-	●	●
Vinegar	●	●	-	●	-	●
Water with glycol	●	●	-	-	●	●
Xilol	-	●	-	-	●	●

- Compatible
- Not compatible





















PROTECTION CLASS FOR COILS WITH CONNECTOR



















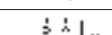
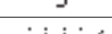
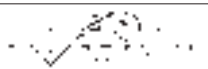

For protection class, we mean the intrinsic ability of live electrical equipment to protect and to protect itself against casual contacts and penetration of solid particles and water. It is defined with the abbreviation "I.P." followed by 2 figures: the first, 0 to 6, defines the protection against casual contacts and penetration of foreign particles; the second, 0 to 8, the protection against water.

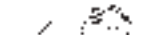
The tables shown below describe the various degrees.

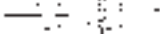
Protection class against casual contacts and penetration of foreign particles		
First figure	Denomination	Explanation
0	No protection.	No special protection for people against casual contacts with live parts or moving parts. No protection of the equipment against the penetration of foreign solid particles.
1	Protection against the penetration of large-sized solid particles.	Protection against casual contacts of large surfaces with live parts or moving parts inside the equipment, for example contacts with hands, but no protection against the voluntary access to these parts. Protection of the equipment against the penetration of solid particles with a diameter larger than 50 mm.
2	Protection against the penetration of fluid-sized solid particles.	Protection against contacts of fingers with live parts or moving parts inside the equipment. Protection against the penetration of solid particles with a diameter larger than 12 mm, such as fingers.
3	Protection against the penetration of small-sized solid particles.	Protection against contacts of tools, wires or the like, thicker than 2.5 mm with live parts or moving parts inside the equipment. Protection against the penetration of solid particles with a diameter larger than 2.5 mm, such as tools, wires, and so on.
4	Protection against the penetration of very small-sized solid particles.	Protection against contacts of tools, wires or the like, thicker than 1 mm with live parts or moving parts inside the equipment. Protection against the penetration of solid particles with a diameter larger than 1 mm, such as thin tools and wires and so on.
5	Protection against dust deposits.	Full protection against contacts with means of any kind with live parts or moving parts inside the equipment. Protection against dust deposits. The penetration of dust is not fully eliminated, but it is reduced to such an extent as to assure the good operation of the equipment.
6	Protection against dust penetration.	Full protection against contacts with means of any kind with live parts or moving parts inside the equipment. Protection against dust deposits. Full protection against the penetration of dust.

Protection class against penetration of water		
Second figure	Denomination	Explanation
0	No protection.	No special protection.
1	Protection against water drops falling perpendicularly.	Water drops that fall perpendicularly must not cause harmful effect.
2	Protection against water drops falling slantwise.	Water drops that fall at a slanted angle of up to 15° to the perpendicular direction must not cause harmful effect.
3	Protection against water dripping.	Water that falls at a slanted angle of up to 60° to the perpendicular direction must not cause harmful effect.
4	Protection against water sprays.	Water sprayed against the equipment from any direction must not cause harmful effect.
5	Protection against water jets.	Water jets fired against the equipment from any direction must not cause harmful effect.
6	Protection against inundation.	The water penetrating into the equipment due to a temporary flood, for example during rough sea conditions, must not cause harmful effect.
7	Protection against immersion.	Water must not penetrate in such a quantity as to damage the equipment, should the equipment itself be immersed for pre-established times and at pre-defined pressure.
8	Protection against submersion.	Water must not penetrate in such a quantity as to damage the equipment, should the equipment itself be submerged at pre-defined pressure and for an undetermined period of time.

Pipes and connections		
Designation	Explanation	Symbol
Pressure line	Line for the energy transfer	
Control line	Line for the transfer of the control energy (including regulation)	
Exhaust or leakage line		
Line connection	Fixed connection, e.g. welded, soldered, screwed (including fittings)	
Crossover	Crossing of unconnected lines	
Flexible line	Connectors of mobile parts	
Electric line	Line for transmitting electrical energy	
Pneumatic pressure source		
Discharge point or vent		
Air exhaust	With not threaded connection	
	With threaded connection	
Compressed air pick-up point	With plug	
	With connecting line	
Quick-acting couplings	Connected, without check valve	
	Connected, with check valve	
	Uncoupled with open end	
	Uncoupled, end blocked by check valve	
Rotating joint (device that allows a rotating movement)	1-way	
	3-way	
Silencer		
Pneumatic accumulator (capacity)		

Air treatment equipment		
Designation	Explanation	Symbol
Air filter	Device for removing impurity	
Condensate separator	With manual draining	
	With automatic draining	
Filter with condensate separator	With manual draining	
	With automatic draining	
Air drier	Device in which the air is dried	
Lubricator	Device in which small quantities of oil are added to the air flowing through it	
Sequence valve	Valve which, by opening the outlet against the spring force, makes connection with further units	
Pressure reducer (valve which to a large extent holds the outlet pressure at a constant level, even with altered inlet pressure)	Without exhaust valve	
	With exhaust valve (Relieving)	
	Piloted pressure reducer with exhaust valve (Relieving)	
Pneumoelectric transducer	Device converting an input pneumatic signal into an output electrical signal	
Pressure switch	Device switching at an adjustable fixed pressure	
Filter - pressure reducer lubricator group (Detailed symbol)		
Filter - pressure reducer lubricator group (Simplified symbol)		
Filter - pressure reducer group		
Soft - start valve	Pneumatic actuated	
	Solenoid actuated	
Pressure gauge		
Thermometer		
Flowmeter		
Totalizer flowmeter		
Optical tester	Device indicating the presence of pressure by means of an optical reflector	

GRAPHIC SYMBOLS

Distribution		
Designation	Explanation	Symbol
2/2 port valve	Two positions at rest, normally closed (N.C.)	
	Two positions at rest, normally open (N.O.)	
3/2 port valve	Two positions at rest, normally closed (N.C.)	
	Two positions at rest, normally open (N.O.)	
4/2 port valve	With two positions and one exhaust	
3/3 port valve	With three positions and closed the neutral one	
5/2 port valve	With two positions and two exhausts	
5/3 port valve	Open centre	
	Pressure centre	
	Closed centre	
Check valve	Unloaded (without spring)	
	Spring-loaded	
Controlled check valve	Pilot operated to close check valve	
	Pilot operated to open check valve	
Shuttle valve (OR type)	The inner port with the higher pressure is automatically connected to the outlet port, while the other inlet port is closed	
Quick-exhaust valve	When the inlet port is not supplied with air, the outlet port is exhausted directly into the atmosphere	
Flow regulator	Bidirectional	
	Unidirectional fixed	
	Unidirectional adjustable	
Flow divider	The flow is divided in two quite similar parts that are independent from the variations of pressure	
Shut-off valve	Two port	
	Three port	
Two pressure valve (AND type)	The outlet port is pressurized only when pressure is supplied to both of the inlet ports	

Controls		
Designation	Explanation	Symbol
Manual actuation	General (without specifying the type of control)	
	By push-button	
	By lever	
	By pedal	
	By pedal with safety device	
	Mechanical actuation	By stem or key
	By spring	
	By roller lever	
	By unidirectional roller lever	
	Pneumatic actuation	Direct action by application of pressure
	Direct action by pressure relief	
	Differential (i.e. pressure dominant pilot)	
	Indirect actuation by application of pressure to the pilot valve	
	Indirect actuation by relieving of pressure on the pilot valve	
Electrical actuation	By solenoid with one winding	
	By solenoid with two in-phase windings	
	By solenoid with two opposing windings	
Combined actuation	By solenoid with one pilot valve	
	By solenoid pilot assisted	
Detent	Device for maintaining a given position	
Release unit	Device for preventing the equipment from blocking at a dead spot	

Technical information

0

GRAPHIC SYMBOLS

Energy conversion (actuators)		
Designation	Explanation	Symbol
Compressor	With constant displacement volume (only one direction of rotation)	
Pneumatic motor with constant displacement volume	With one direction of rotation	
	With two directions of rotation	
Pneumatic motor with variable displacement volume	With one direction of rotation	
	With two directions of rotation	
Pneumatic rotary cylinder	With rotary drive limited range of oscillation	
Single acting cylinder	Front spring	
	Rear spring	
Double acting cylinder		
Double acting cylinder through rod		
Tandem cylinder	Opposed	
	Double push	
	Double stroke	
Telescopic cylinder	Single acting	
	Double acting	
Pressure multiplier	For fluids with the same characteristics	
	For fluids with different characteristics	

Rod and piston unit options		
Designation	Explanation	Symbol
Rod and piston unit	Standard	
	With adjustable cushioning at one end	
	With adjustable cushioning at both ends	
	With magnetic piston	
	With magnetic piston and adjustable cushioning at one end	
	With magnetic piston and adjustable cushioning at both ends	
	With non-rotating piston rod device	
	With piston rod locking unit	

COMPARISON AND DESIGNATION OF CONNECTIONS

Port	ISO 5599	Letter designations
Supply/inlet port	1	P
Working or outlet line	2	B
Exhaust line	3	S
Working or outlet line	4	A
Exhaust line	5	R
Pilot line that reset the output signal	10	Z
Pilot line	12	Y
Pilot line	14	Z
Pre-pilot exhaust line	82	—
Pre-pilot exhaust line	84	—

MULTIPLES AND SUB-MULTIPLES

Prefix	Symbol	Factor
yotta	Y	10 ²⁴
zetta	Z	10 ²¹
exa	E	10 ¹⁸
peta	P	10 ¹⁵
tera	T	10 ¹²
giga	G	10 ⁹
mega	M	10 ⁶
kilo	k	10 ³
etto	h	10 ²
deca*	da	10
deci	d	10 ⁻¹
centi	c	10 ⁻²
milli	m	10 ⁻³
micro	μ	10 ⁻⁶
nano	n	10 ⁻⁹
pico	p	10 ⁻¹²
femto	f	10 ⁻¹⁵
atto	a	10 ⁻¹⁸
zepto	z	10 ⁻²¹
yocto	y	10 ⁻²⁴

*In the U.S.A. this prefix is commonly defined "deka"

CONSUMPTION OF AIR TABLE

Cylinder bore D (mm)	Piston rod diameter d (mm)	Motion	Useful area cm ²	Consumption of air in thrust and in traction expressed in Nl per cm of stroke as a function of the operating pressure P expressed in bar, at 20°C									
				1 bar	2 bar	3 bar	4 bar	5 bar	6 bar	7 bar	8 bar	9 bar	10 bar
12	4	Thrust	1,13	0,0023	0,0034	0,0045	0,0057	0,0068	0,0079	0,009	0,0102	0,0113	0,0124
		Traction	1	0,002	0,003	0,004	0,005	0,006	0,007	0,008	0,009	0,01	0,011
16	6	Thrust	2,01	0,004	0,006	0,008	0,01	0,0121	0,0141	0,0161	0,0181	0,0202	0,0221
		Traction	1,73	0,0035	0,0052	0,0069	0,0086	0,0104	0,0121	0,0138	0,0156	0,0173	0,019
20	8	Thrust	3,14	0,0063	0,0094	0,0126	0,0157	0,0188	0,022	0,0251	0,0283	0,0314	0,0346
		Traction	2,64	0,0053	0,0079	0,0106	0,0132	0,0158	0,0185	0,0211	0,0238	0,0264	0,029
25	12	Thrust	4,91	0,0098	0,0147	0,0196	0,0245	0,0295	0,0344	0,0393	0,0442	0,0491	0,054
		Traction	3,78	0,0076	0,0113	0,0151	0,0189	0,0227	0,0264	0,0302	0,034	0,0378	0,0415
32	12	Thrust	8,04	0,016	0,024	0,032	0,04	0,048	0,056	0,064	0,072	0,08	0,088
		Traction	6,91	0,014	0,021	0,028	0,035	0,042	0,049	0,058	0,063	0,07	0,076
40	16	Thrust	12,56	0,025	0,038	0,05	0,063	0,076	0,088	0,1	0,113	0,126	0,138
		Traction	10,55	0,021	0,032	0,042	0,053	0,063	0,074	0,088	0,095	0,106	0,116
50	20	Thrust	19,63	0,039	0,059	0,079	0,098	0,118	0,137	0,157	0,177	0,196	0,216
		Traction	16,49	0,033	0,05	0,066	0,082	0,099	0,115	0,132	0,149	0,165	0,181
63	20	Thrust	31,16	0,062	0,093	0,125	0,156	0,187	0,218	0,249	0,28	0,312	0,343
		Traction	28,02	0,056	0,084	0,112	0,14	0,168	0,196	0,224	0,252	0,28	0,308
80	25	Thrust	50,24	0,1	0,15	0,2	0,25	0,301	0,351	0,402	0,452	0,502	0,552
		Traction	45,36	0,091	0,138	0,181	0,227	0,272	0,318	0,363	0,408	0,454	0,5
100	32	Thrust	78,54	0,157	0,238	0,314	0,382	0,471	0,549	0,628	0,706	0,785	0,862
		Traction	70,5	0,141	0,211	0,282	0,352	0,423	0,493	0,564	0,635	0,705	0,775
125	32	Thrust	122,66	0,245	0,368	0,49	0,613	0,736	0,859	0,981	1,104	1,226	1,349
		Traction	114,67	0,229	0,344	0,459	0,573	0,688	0,803	0,917	1,032	1,147	1,262
160	40	Thrust	201,06	0,402	0,603	0,804	1,005	1,206	1,407	1,608	1,809	2,01	2,211
		Traction	188,49	0,377	0,565	0,754	0,942	1,13	1,319	1,508	1,696	1,884	2,073
200	40	Thrust	314,15	0,628	0,942	1,257	1,571	1,885	2,199	2,513	2,827	3,145	3,456
		Traction	301,59	0,603	0,905	1,206	1,508	1,81	2,111	2,413	2,714	3,016	3,318
250	50	Thrust	490,87	0,982	1,473	1,963	2,454	2,945	3,436	3,927	4,418	4,909	5,400
		Traction	471,24	0,943	1,414	1,885	2,356	2,827	3,299	3,770	4,241	4,712	5,184
320	63	Thrust	804,25	1,608	2,413	3,217	4,021	4,825	5,630	6,434	7,238	8,042	8,847
		Traction	773,08	1,546	2,319	3,092	3,865	4,638	5,411	6,185	6,958	7,731	8,504

The following formula is used to determinate the consumption of air:

$$Q = H \times (S+T) \times N \quad \text{where:}$$

Q = consumption of air (Nl/min)

H = cylinder stroke (cm)

S = consumption of air per 1 cm of stroke in thrust

T = consumption of air per 1 cm of stroke in traction

N = number of cycles per minute

Technical information

0 PEAK LOAD AND THEORETICAL FORCES

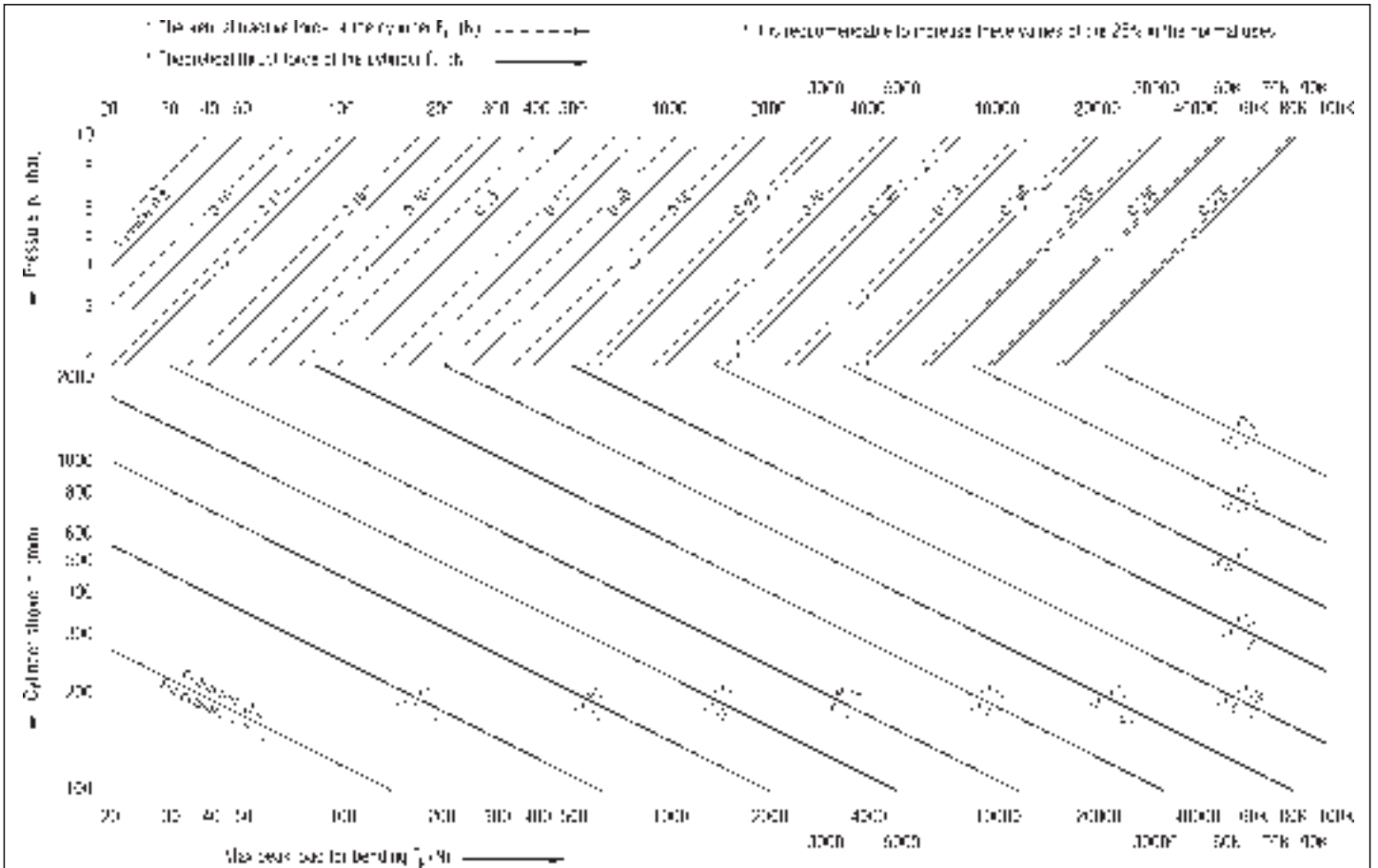

In particular applications the piston rod of the cylinder may be subjected to the peak load; it is then important to control the piston rod diameter in relation to the stroke that should be made, the force developed by the cylinder, the working pressure and the fixings.

The diagram shown has been realized considering the worst condition, consisting in a rear hinge fixing on the cylinder body (in vertical position with the load charging the rod end) and fork on the piston rod.

Given the stroke, the relevant horizontal line is followed until the relevant line to the piston rod diameter (cylinder bore) is crossed; from that point, drawing the vertical line till reaching the x-axis, is obtainable the maximum acceptable peak load.

CUSHIONING DIAGRAM

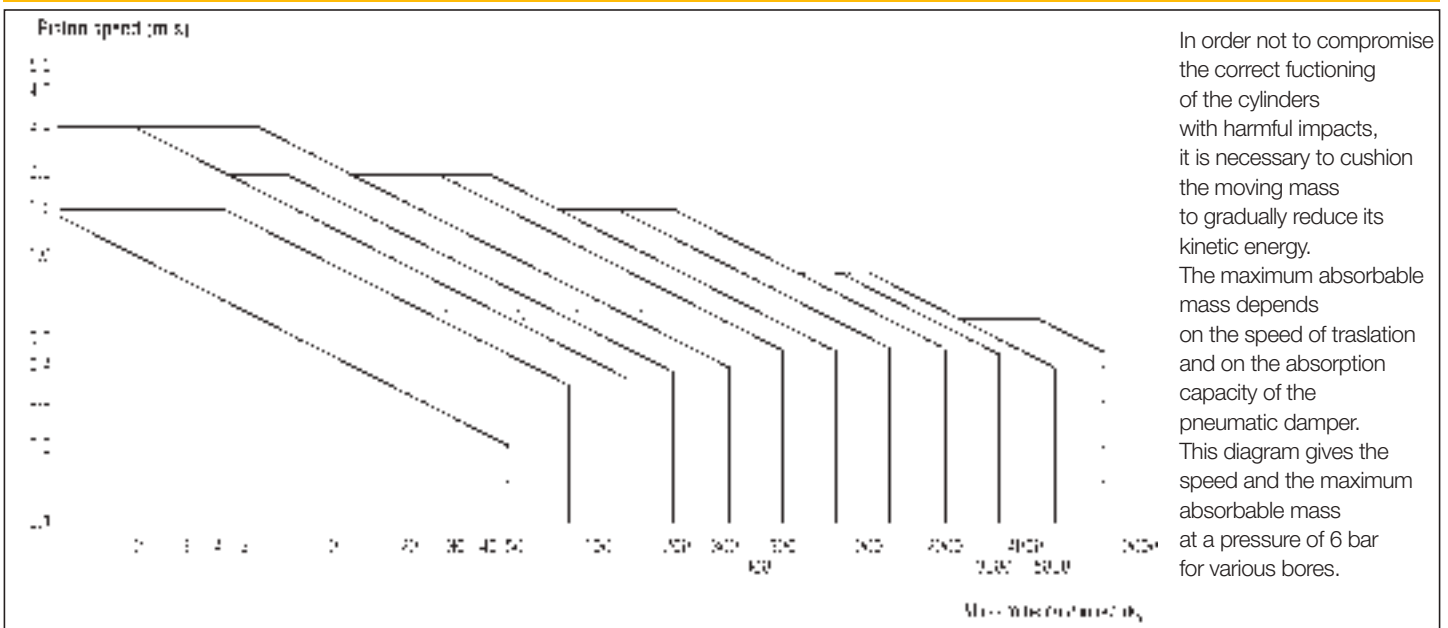

SPRING THEORETICAL TRACTIVE FORCE FOR SINGLE ACTING CYLINDERS

SERIES X-XT

Stroke (mm)	5		10		15		20		25		30	
Bore (mm)	F.min (N)	F.max (N)	F.min (N)	F.max (N)	F.min (N)	F.max (N)	F.min (N)	F.max (N)	F.min (N)	F.max (N)	F.min (N)	F.max (N)
32	6,2	7,9	-	-	4,6	9,5	-	-	3,8	10,8	-	-
40	-	-	6,9	9,3	7,1	10,3	-	-	6,5	11,1	-	-
50	-	-	12	24,7	-	-	11,1	28,3	-	-	10,9	30,1
63	-	-	13	19,5	-	-	12,4	22,7	-	-	-	-
80-100	18,5	20	-	-	17,5	21,9	-	-	-	-	15,8	23,5

Stroke (mm)	35		40		45		50		100	
Bore (mm)	F.min (N)	F.max (N)	F.min (N)	F.max (N)	F.min (N)	F.max (N)	F.min (N)	F.max (N)	F.min (N)	F.max (N)
32	3,9	12,2	4,3	13	4,8	13,5	6,5	14,4	-	-
40	5,8	11,7	-	-	-	-	5,6	12,2	-	-
50	-	-	10,5	31,2	12,5	31,9	13,9	32,4	-	-
63	9,7	24,8	11,5	26,3	-	-	11,3	27,5	-	-
80-100	-	-	15,2	24,8	-	-	14,9	26	10,3	30,9

SERIES C

Bore (mm)	Stroke (mm)					
	5		10		15	
	F.min (N)	F.max (N)	F.min (N)	F.max (N)	F.min (N)	F.max (N)
6	1,6	3,7	1,6	3,9	1,6	3,9
10	7,4	11,5	6	12,5	6,8	12,8
16	8,4	9,5	8,4	10,7	7,4	10,7

SERIES U

Bore (mm)	Stroke max (mm)	F.min (mm)	F.max (mm)
8 - 10	20	1,5	2
12 - 16	50	2	4
20	50	2,9	5,8
25	50	7,3	11,1

SERIES P

Bore (mm)	Stroke max (mm)	F.min (mm)	F.max (mm)
32	50	11,5	60,9
40	50	46,4	84,5
50	50	72	124,3
63	50	66,3	142

SERIES BX

Bore (mm)	Stroke max (mm)	F.min (mm)	F.max (mm)
20	25	4	9
25	25	7	22
32	25	11	27
40	25	19	36
50	25	32	54
63	25	41	76
80	25	58	96
100	25	55	95

SERIES BU

Bore (mm)	Stroke max (mm)	F.min (mm)	F.max (mm)
20	25	6	17
25	25	10	37
32	25	20	51
40	25	24	52
50	25	39	69
63	25	54	92
80	25	76	125
100	25	111	179

SERIES B

Bore (mm)	Stroke max (mm)	F.min (mm)	F.max (mm)
12-16	25	6	13
20	25	8	23
25	25	11	28
32	30	14	37
40	30	25	73
50	30	40	100
63	30	45	111
80	30	70	166
100	30	90	198

SERIES HB

Bore (mm)	Stroke max (mm)	F.min (mm)	F.max (mm)
20	20	12	33
27	25	40	85
35	35	30	67
40	60	39	84
50-70	70	48	120
58	60	54	139
85	90	75	225
100	100	81	259

Technical information

0

CONVERSION TABLES

Torque

	inchounce (ozf-in)	inchpound (lbf-in)	footpound (lbf-ft)	kilogrammetro (kgf-m)	Newtonmetro (N-m)
1 inchounce =		0,0625	0,0052	$7,2 \cdot 10^{-4}$	$7,06 \cdot 10^{-3}$
1 inchpound =	16		0,0833	$1,152 \cdot 10^{-2}$	0,113
1 footpound =	192	12		0,1383	1,356
1 kilogrammetro =	1388,7	86,796	7,233		9,80665
1 Newtonmetro =	141,6	8,85	0,7375	0,102	

Length

	Inch (in)	foot (ft)	yard (yd)	millimeter (mm)	meter (m)
1 inch =		0,0833	0,0278	25,4	0,0254
1 foot =	12		0,333	304,8	0,304
1 yard =	36	3		914,4	0,9144
1 millimeter =	0,03937	0,0033	0,00109		0,001
1 meter =	39,37	3,2808	1,0936	1000	

Area

	inch ² (in ²)	foot ² (ft ²)	yard ² (yd ²)	square millimeter (mm ²)	square meter (m ²)
1 inch ² =		0,0069	0,00077	645,16	$6,45 \cdot 10^{-4}$
1 foot ² =	144		0,111	92903	0,0929
1 yard ² =	1296	9		836100	0,8361
1 millimeter ² =	0,0016	$1,0764 \cdot 10^{-5}$	$1,196 \cdot 10^{-6}$		10^{-6}
1 meter ² =	1550	10,764	1,196	10^6	

Force

	Newton (N)	kilopound (kp)	poundforce (lbf)
1 Newton =		0,10197	0,22481
1 kilopound =	9,80665		2,20463
1 poundforce =	4,4482	0,45359	

Density

	ounce / inch ³ (ozf / in ³)	pound / foot ³ (lbf / ft ³)	grams / centimeter ³ (g/cm ³)
1 ounce / inch ³ =		108	1,73
1 pound / foot ³ =	0,0092		0,016
1 gram / centimeter ³ =	0,578	62,43	

Mass

	ounce (oz)	pound (lb)	Kilogram (kg)
1 ounce =		0,0625	0,0283
1 pound =	16		0,4536
1 Kilogram =	35,274	2,2046	

Speed

	foot/second (ft/s)	foot/minute (ft/min)	mile/hour (mi/h)	meter/second (m/s)	Kilometers/hour (km/h)
1 foot/second =		60	0,6818	0,3048	1,097
1 foot/minute =	0,017		0,0114	0,00508	0,01829
1 mile/hour =	1,4667	88		0,447	1,609
1 meter/second =	3,28	196,848	2,237		3,6
1 Kilometer/hour =	0,9113	54,68	0,6214	0,278	

Temperature

	Kelvin (K)	Celsius degree (°C)	Fahrenheit degree (°F)
1 K =		K - 273,15	K · 9/5 - 459,67
1 °C =	$^{\circ}\text{C} + 273,15$		$^{\circ}\text{C} \cdot 9/5 + 32$
1 °F =	$5/9 \cdot (^{\circ}\text{F} - 32) + 273,15$	$(^{\circ}\text{F} - 32) \cdot 5/9$	

Volume

	inch ³ (in ³)	US quart (liq qt)	Imperial gallon (UK) (Imp gall)	foot ³ (cu ft)	US gallon (gal)	liter (l)
1 inch ³ =		0,0173	0,0036	0,00058	0,0043	0,0164
1 US quart =	57,75		0,2082	0,0334	0,25	0,9464
1 Imperial gallon =	277	4,8		0,1604	1,2	4,546
1 foot ³ =	1728	29922	6,23		7,48	28,317
1 US gallon =	231	4	0,8327	0,1337		3,785
1 liter =	61,024	1,0567	0,22	0,0353	0,264	

Pressione

	inch Hg	psi	atmosphère	torr	mm Hg	bar	Mpa	kg/cm ²
1 inch Hg =		0,491	0,0334	25,4	25,4	0,0339	0,00339	0,0345
1 psi =	2,036		0,068	51,715	51,715	0,0689	0,00689	0,0703
1 atmosphère =	29,921	14,696		760	760	1,0133	0,10133	1,0332
1 torr =	0,0394	0,0193	0,0013		1	0,0013	0,00013	0,00136
1 mm Hg =	0,0394	0,0193	0,0013	1		0,0013	0,00013	0,00136
1 bar =	29,53	14,504	0,987	749,87	749,87		0,1	1,02
1 Mpa =	295,3	145,04	9,869	7498,7	7498,7	10		10,2
1 kg/cm ² =	28,95	14,22	0,968	735,35	735,35	0,98	0,098	

Flow rate

	m ³ /s	l/s	cm ³ /s	m ³ /h	m ³ /min	l/h	l/min	ft ³ /min (scfm)	UK Gallon/min	US Gallon/min
1 m ³ /s =		10 ³	10 ⁶	3600	60	$3,6 \cdot 10^3$	60-103	$2,1188 \cdot 10^3$	$13,198 \cdot 10^3$	$15,850 \cdot 10^3$
1 l/s =	10^{-3}		10^3	3,6	60-10 ⁻³	$3,6 \cdot 10^3$	60	2,1188	13,198	15,85
1 cm ³ /s =	10^{-6}	10^{-3}		$3600 \cdot 10^{-6}$	$60 \cdot 10^{-6}$	3,6	$60 \cdot 10^{-3}$	$2,1188 \cdot 10^{-3}$	$13,198 \cdot 10^{-3}$	$15,850 \cdot 10^{-3}$
1 m ³ /h =	$0,277778 \cdot 10^{-3}$	0,27778	$0,277778 \cdot 10^3$		$16,667 \cdot 10^{-3}$	10^3	16,667	0,58856	3,6661	4,4028
1 m ³ /min =	$16,667 \cdot 10^{-3}$	16,667	$16,667 \cdot 10^3$	60		6-104	10^3	35,313	219,97	$264,17 \cdot 10^{-3}$
1 l/h =	$0,27778 \cdot 10^{-6}$	$0,27778 \cdot 10^{-3}$	0,27778	10^{-3}	$16,667 \cdot 10^{-6}$		$16,667 \cdot 10^{-3}$	$0,58856 \cdot 10^{-3}$	$3,6661 \cdot 10^{-3}$	$4,4028 \cdot 10^{-3}$
1 l/min =	$16,667 \cdot 10^{-6}$	$16,667 \cdot 10^{-3}$	$16,667 \cdot 10^{-6}$	$60 \cdot 10^{-3}$	10-3	60^{-3}		$35,313 \cdot 10^{-3}$	$219,97 \cdot 10^{-3}$	$264,17 \cdot 10^{-3}$
1 ft ³ /min =	$0,47195 \cdot 10^{-3}$	0,47195	$0,47195 \cdot 10^3$	1,699	$28,317 \cdot 10^{-6}$	$1,6990 \cdot 10^3$	28,317		6,2288	7,4804
1 gallon m. UK =	$75,768 \cdot 10^{-6}$	$75,768 \cdot 10^{-3}$	75,768	0,27276	$4,5461 \cdot 10^{-3}$	272,76	4,5461	0,16054		1,2009
1 gallon m. USA =	$63,090 \cdot 10^{-6}$	$63,090 \cdot 10^{-3}$	63,09	0,22712	$3,7854 \cdot 10^{-3}$	227,12	3,7854	0,13368	0,83266	

THREADS COMPARISON TABLE

Ø external (mm)	Ø core (mm)	lead* - turns/inch	metric coarse pitch	metric fine pitch	BSP, G	NPT	UNF
3,8 ÷ 3,9	3,2 ÷ 3,4	0,7	M 4				
4 ÷ 4,2	3,4 ÷ 3,6	36					No. 8-36
4,6 ÷ 4,8	4,0 ÷ 4,2	32					No.10-32
4,8 ÷ 4,9	4,1 ÷ 4,3	0,8	M 5				
5,7 ÷ 5,9	4,9 ÷ 5,2	1	M 6				
7,7 ÷ 7,9	6,9 ÷ 7,2	1		M 8 x 1			
7,7 ÷ 7,9	6,6 ÷ 6,9	1,25	M 8				
7,7 ÷ 7,9	6,8 ÷ 7,1	24					5/16 x 24
maximum 7,9	minimum 6	27				1/16	
9,5 ÷ 9,7	8,5 ÷ 8,8	28			1/8		
9,7 ÷ 9,9	8,9 ÷ 9,2	1		M 10 x 1			
9,7 ÷ 9,9	8,6 ÷ 8,9	1,25		M 10 x 1,25			
9,7 ÷ 9,9	8,4 ÷ 8,7	1,5	M 10				
maximum 10,3	minimum 8,3	27				1/8	
10,9 ÷ 11,1	9,7 ÷ 10	20					7/16 x 20
11,7 ÷ 11,9	10,6 ÷ 10,9	1,25		M 12 x 1,25			
11,7 ÷ 11,9	10,4 ÷ 10,7	1,5		M 12 x 1,5			
11,6 ÷ 11,9	10,1 ÷ 10,4	1,75	M 12				
12,5 ÷ 12,7	11,3 ÷ 11,7	20					1/2 x 20
12,9 ÷ 13,2	11,4 ÷ 11,9	19			1/4		
13,6 ÷ 13,9	11,8 ÷ 12,2	2	M 14				
maximum 13,7	minimum 10,7	18				1/4	
15,7 ÷ 15,9	14,4 ÷ 14,7	1,5		M 16 x 1,5			
15,6 ÷ 15,9	13,8 ÷ 14,2	2	M 16				
15,7 ÷ 15,9	14,4 ÷ 14,7	16					5/8 x 16
16,4 ÷ 16,7	14,9 ÷ 15,4	19			3/8		
maximum 17,1	minimum 14,2	18				3/8	
17,6 ÷ 17,9	15,3 ÷ 15,7	2,5	M 18				
18,8 ÷ 19,1	17,3 ÷ 17,8	16					3/4 x 16
19,7 ÷ 19,9	18,9 ÷ 19,2	1		M 20 x 1			
19,7 ÷ 19,9	18,4 ÷ 18,7	1,5		M 20 x 1,5			
19,6 ÷ 19,9	17,3 ÷ 17,7	2,5	M 20				
20,7 ÷ 20,9	18,6 ÷ 19,2	14			1/2		
maximum 21,3	minimum 17,4	14				1/2	
21,7 ÷ 21,9	20,4 ÷ 20,7	1,5		M 22 x 1,5			
21,9 ÷ 22,6	20,3 ÷ 20,8	14					7/8 x 14
23,7 ÷ 23,9	22,4 ÷ 22,7	1,5		M 24 x 1,5			
23,6 ÷ 23,9	20,8 ÷ 21,3	3	M 24				
25,1 ÷ 25,4	23,1 ÷ 23,6	12					1 x 12
26,2 ÷ 26,4	24,1 ÷ 24,7	14			3/4		
26,6 ÷ 26,9	24,8 ÷ 25,2	2		M 27 x 2			
maximum 26,7	minimum 22,5	14				3/4	
28,3 ÷ 28,6	26,3 ÷ 26,8	12					1 1/8 x 12
29,7 ÷ 29,9	28,4 ÷ 28,7	1,5		M 30 x 1,5			
31,5 ÷ 31,7	29,5 ÷ 30	12					1 1/4 x 12
32,9 ÷ 33,2	30,3 ÷ 30,9	11			1		
maximum 33,4	minimum 28,5	11 1/2				1	
35,7 ÷ 35,9	34,4 ÷ 34,7	1,5		M 36 x 1,5			
35,6 ÷ 35,9	33,8 ÷ 34,2	2		M 36 x 2			
37,7 ÷ 37,9	36,4 ÷ 36,7	1,5		M 38 x 1,5			
37,8 ÷ 38,1	35,8 ÷ 36,4	12					1 1/2 x 12
41,6 ÷ 41,9	38,9 ÷ 39,6	11			1 1/4		
41,7 ÷ 41,9	40,4 ÷ 40,7	1,5		M 42 x 1,5			
41,6 ÷ 41,9	39,8 ÷ 40,2	2		M 42 x 2			
maximum 42,2	minimum 37	11 1/2				1 1/4	
44,7 ÷ 44,9	43,4 ÷ 43,7	1,5		M 45 x 1,5			
47,9 ÷ 47,8	44,8 ÷ 45,5	11			1 1/2		
47,6 ÷ 47,9	45,8 ÷ 46,2	2		M 48 x 2			
maximum 48,3	minimum 43,5	11 1/2				1 1/2	
59,3 ÷ 59,6	56,7 ÷ 57,3	11			2		
59,7 ÷ 59,9	58,4 ÷ 58,7	1,5		M 60 x 1,5			
maximum 60,3	minimum 55	11 1/2				2	
79,7 ÷ 79,9	78,4 ÷ 78,7	1,5		M 80 x 1,5			

* for metric screw thread

metric = metric screw thread (coarse pitch = MA; fine pitch = MB)
 G = Gas thread ("BSP" according to ISO standard)
 NPT = tapered gas thread (used in the U.S.A.)
 UNF = fine pitch thread (used in the Anglo-Saxon countries)

0 GENERAL TECHNICAL DATA FOR CYLINDERS

OPERATING LIFE

The life cycle of cylinders is affected by manifold factors including: loads (axial and radial), speeds and frequencies of use, average working temperatures, shocks, tolerances of the acceptable pneumatic leakage. Due to the variability of all the factors above mentioned it's not possible to give indications on the life of cylinders that would not be purely theoretical data. The intent of these indications is only to supply a reference value that could help the end user to planning properly during the implementation phase of any installation, and not binding or guaranteed towards the customer. In consideration of all the above, we can give the following values (without radial loads):

- 15,000 km for cylinders with polyurethane seals;
- 8,000 km for cylinders with NBR seals;
- 5,000 km for rodless cylinders.

STROKE TOLERANCES

The actual stroke of the cylinders has a tolerance with respect to the nominal stroke but always in compliance with the applicable standards, if any, or anyway within the following tolerances:

- -0/+1.5 mm for cylinders to ISO 6432 Ø 8 ÷ 25;
- -0.5/+1.5 mm for round cylinders Ø 32 ÷ 63;
- -0/+2 mm for cylinders to ISO 15552 Ø 32 ÷ 50;
- -0/+2.5 mm for cylinders to ISO 15552 Ø 63 ÷ 320;
- -0/+2.5 mm for compact cylinders to AFNOR Ø 20 ÷ 100;
- -0/+1 mm for compact cylinders Ø 12 ÷ 100;
- -0/+2.5 mm for rodless cylinders Ø 18 ÷ 63.

STROKES EXCEEDING THE MAXIMUM VALUE INDICATED IN THE CATALOGUE

Customer can address our commercial office even the "Demand for Feasibility" of cylinders having strokes exceeding the maximum value indicated in the catalogue. By and large Waircom will always be able to supply these cylinders, obviously with the physical limitations of the production technologies, but it will be care and responsibility of only the end user to realize proper solutions (e.g. guiding the piston rod, avoiding peaks loads, etc.) so that these cylinders with non-standard strokes could work properly and securely.

MAGNETIC SENSORS

The intensity and the shape of the magnetic fields generated by permanents magnets housed in the piston assembly depend on the presence of magnetic metal masses in the vicinity of the cylinders that could create mutual magnetic inductance. Therefore these masses may prevent the sensors from switching correctly, in which case non-magnetic materials should be used as, for instance, convenient stainless steel.

INSULATION CLASS - COILS

INSULATION CLASS	TEMPERATURE °C
Y	90
A	105
E	120
B	130
F	155
H	180
200	200
220	220
250	250

The indicated temperature is the effective temperature of the insulation and not the over temperature.

CONTINUOUS SERVICE "ED" - COILS

The coils are normally expected to be used in continuous service (ED 100%). Definition of "Continuous service": when the electrical connection time exceed the thermal constant of the coil by approx. 1/4. As a general rule, the continuous service correspond to an electrical connection time that is equal or higher than 15 minutes. It's possible, for non-continuous service (e.g.ED50%), either to have coils at powers that are higher than the standard ones, or to use the coils with an ambient temperature higher than the ones indicated.

$$ED = \frac{\text{connection time}}{(\text{connection time} + \text{disconnection time})} \times 100$$

EXAMPLE:
$$\frac{5' (\text{connection time})}{5' (\text{connection time}) + 5' (\text{disconnection time})} \times 100 = ED 50\%$$



ATEX DIRECTIVE

Since 1st July 2003, all products marketed in the European Union and intended for use in potentially explosive atmospheres must be approved in compliance with European Directive 2014/34/EU, also known as ATEX.

ATEX word comes from French "Atmosphères Explosibles", ie explosive atmosphere.

Explosive atmosphere means a mixture with air, under atmospheric conditions of flammable substances in the form of gases, vapours, mists (or dusts) in which, after ignition has occurred, combustion spreads to the entire unburned mixture (1999/92/CE directive, EN 13237)

A source ignition can be:

- a)** of electrical origin (electric arcs, induced currents, heat generated by the Joule effect);
- b)** of mechanical origin (hot surface generated by friction, sparks generated by impact between metal bodies, electrostatic discharge, adiabatic compression);
- c)** of chemical origin (exothermic reaction between materials);
- d)** naked flames.

An explosive atmosphere that, if explodes, causes damage is called dangerous (EN 1127-1).

The main points introduced by the directive are:

- a)** non-electrical equipment and devices, such as pneumatic cylinders, pneumatic valves and air treatment groups are inserted in the directive;
- b)** each device is assigned a category associated to certain potentially explosive atmospheres;
- c)** all products must bear the CE marking;
- d)** each device sold for use in potentially explosive areas must be provided with instructions for use and declaration of conformity;
- e)** the devices are intended for use in potentially explosive atmosphere for the presence of dust fall in the directive similar to products intended for areas with the presence of dust fall in the directive similar to products intended for areas with the presence of dangerous gases with the exception of:
 - a)** medical devices
 - b)** equipment intended for use in places of production or storage of explosives
 - c)** equipment on board ships, or offshore
 - d)** transportation (excluding those for use in explosive atmosphere)
 - e)** equipment for household use
 - f)** biogas plants

Products subject to approval are all those which, during normal use or due to a malfunction, present one or more sources of ignition for potentially explosive atmospheres.

Responsibility lies both with the manufacturer of the device and whoever installs it in equipment that is to operate in a hazardous atmosphere. This requires co-operation between the parties to ensure correspondence between the category of device and the hazardous area in which it is to operate.

The manufacturer of the device must comply with the specifications and classify the product according to directive 2014/34/EU.

The manufacturer of the equipment, who knows the area in which the device will be operating, must select a suitable device according to the category, pursuant to directive 99/92/EC.

MIXED EQUIPMENT (ELECTRICAL AND MECHANICAL)

According to the Directive 2014/34/EU, both electrical and mechanical devices are subject to the approval of compliance.

The classification of a product composed by multiple devices makes reference to the lowest class of the same devices that compose it.

For example, the product "solenoid valve", composed by the electrical device "coil" marked 3GD and mechanical device "valve" marked 2GD, it will be put into operation only in areas of category 3GD



0 ZONES CLASSIFICATION

Devices for use in potentially explosive areas are divided into the following GROUPS:

- GROUP I: devices used in mines
- GROUP II: devices used in surface installations

ZONES CLASSIFICATION ACCORDING TO THE 2014/34/EU DIRECTIVE:

FEATURES OF THE ENVIRONMENT				FEATURES OF THE EQUIPMENT			
Application environment	Flammable material	Potentially Explosive Atmospheres	Classification of potentially explosive atmospheres: ZONE	According to ATEX 94/9/CE		According to IEC 60079-0 EPL	Required level of protection
				Marking required by the equipment: CATEGORY	Marking required by the equipment: GROUP		
Mine				M1	I	Ma	Very high
				M2		Mb	High
Surface	Gas	It's present continuously, for long periods or frequently	0	1G	II	Ga	Very high
		It's likely present	1	2G		Gb	High
		It's unlikely present and if it's present, it is infrequently and for short periods	2	3G		Gc	Normal
	Dust	It's present continuously, for long periods or frequently	20	1D		Da	Very high
		It's likely present	21	2D		Db	High
		It's unlikely present and if it's present, it is infrequently and for short periods	22	3D		Dc	Normal

CORRESPONDENCES BETWEEN ZONES AND CATEGORIES ACCORDING TO 2014/34/EU DIRECTIVE

ZONE 0 / ZONE 20 => CATEGORY 1: equipment of this category guarantees the required level of safety even under rarely occurring equipment fault conditions. This equipment is used where an explosive atmosphere consisting of a mixture of air and gases, vapours or mist or of a dust/air mixture is present continuously or for long periods.

ZONE 1 / ZONE 21 => CATEGORY 2: equipment of this category guarantees the required level of safety even under frequently occurring equipment fault conditions. This equipment is used where an explosive atmosphere consisting of a mixture of air and gases, vapours or mist or of a dust/air mixture is present occasionally.

ZONE 2 / ZONE 22 => CATEGORY 3: equipment of this category provides the required level of safety under normal operating conditions. This equipment is used in areas where in all probability an explosive atmosphere consisting of a mixture of air and gases, vapours or mist or of a dust/air mixture will occur either not at all or only for a short time.



EXAMPLE OF MARKING FOR MECHANICAL DEVICES (WITHOUT ELECTRICAL COMPONENTS)

	II	2	GD	c	T4	T120 °C	20 °C < Ta < 60 °C
1	2	3	4	5	6	7	8

- 1 - ATEX symbol, indicates that the device can be used in Atex zone
- 2 - Belonging group: mines or other
- 3 - Belonging category: indicates the use in the different areas
- 4 - Type of atmosphere (G=gas D=dust)
- 5 - Method of protection from sources of ignition
- 6 - Class indicating maximum surface temperature reachable by the device. Indication for Gas
- 7 - Maximum surface temperature, written in full, reachable from the device. Indication for Dust
- 8 - Environment temperature for use of the device

EXAPLE OF MARKING FOR MECHANICAL AND ELECTRICAL DEVICES

	II	3	G	Ex	nA c	IIC	T4	Gc	/	20 °C < Ta < 60 °C
1	2	3	4	5	6	7	8	9	10	11
	II	3	D	Ex	Tc	IIIC	T120 °C	Dc	IP65	20 °C < Ta < 60 °C

- 1 - ATEX symbol, indicates that the device can be used in Atex zone
- 2 - Belonging group: mines or other
- 3 - Belonging category: indicates the use in the different areas
- 4 - Type of atmosphere (G=gas D=dust)
- 5 - It indicates that the device can be used in ATEX zone
- 6 - Method of protection from sources of ignition
- 7 - Subdivision of explosion group
 - IIC: explosion subgroup that includes all types of gas
 - IIIC: subgroup subgroup that includes fuels particles, conductive powder and not
- 8 - Maximum temperature of the device:
 - Class indicating maximum surface temperature reachable by the device. Indication for Gas
 - Maximum surface temperature, written in full, reachable from the device. Indication for Dust
- 9 - Equipment Protection Level
- 10 - Degree of protection IP (for dust only)
- 11 - Environment temperature for use of the device



PROTECTION METHODS AND REFERENCE STANDARDS

Protection symbol	Zone						Description	Reference regulation (IEC Ex) (European EN)
	1		2		3			
	G	D	G	D	G	D		
	0	20	1	21	2	22		
Basic requirements	X	X	X	X	X	X	General requirements	IEC 60079-0 EN 60079-0
c			X	X	X	X	Protection by constructional safety	EN 13463-5
d			X		X		Flameproof enclosure. Type of protection in which the parts which can ignite an explosive atmosphere are placed in an enclosure which can withstand the pressure developed during an internal explosion of an explosive mixture and which prevents the transmission of the explosion to the explosive atmospheres surrounding the enclosure.	IEC 60079-1 EN 60079-1
e			X		X		Increased Safety Electrical apparatus with a high safety coefficient	IEC 60079-7 EN 60079-7
i	ia	X					Intrinsic Safety Type of protection when no spark or any thermal effect in the circuit, produced in the test conditions prescribed in the standard (which include normal operation and specific fault conditions), is capable of causing ignition.	IEC 60079-11 EN 60079-11
	ib			X				
	ic					X		
	iD		X		X			X
m	ma	X					Encapsulation Type of protection in which the parts which can ignite an explosive atmosphere are enclosed in a resin sufficiently resistant to the environmental influences in such a way that this explosive atmosphere cannot be ignited by either sparking or heating which may occur within the encapsulation.	IEC 60079-11 EN 60079-11
	mb			X				
	mc					X		
	mD		X		X			X
n					X		Method of protection for electrical equipment designed so that it will not ignite the surrounding explosive atmosphere in normal operation and under certain fault conditions specified in the standard. There are 4 categories of equipment: nA (non-sparking), nC (enclosed break), nR (restricted breathing), nL (limited energy).	IEC 60079-15 EN 60079-15
o			X		X		Oil immersion. Type of protection in which the electrical apparatus is immersed in oil.	IEC 60079-6 EN 60079-6
p	px			X			Pressurized enclosure Type of protection in which the protective inert gas inside the enclosure is maintained at a higher pressure than that of the surrounding atmosphere.	IEC 60079-6 EN 60079-6
	py			X				
	pz					X		
	pD				X			
q			X		X		Type of protection in which the enclosure is filled with a material in a finely granulated state.	IEC 60079-5 EN 60079-5

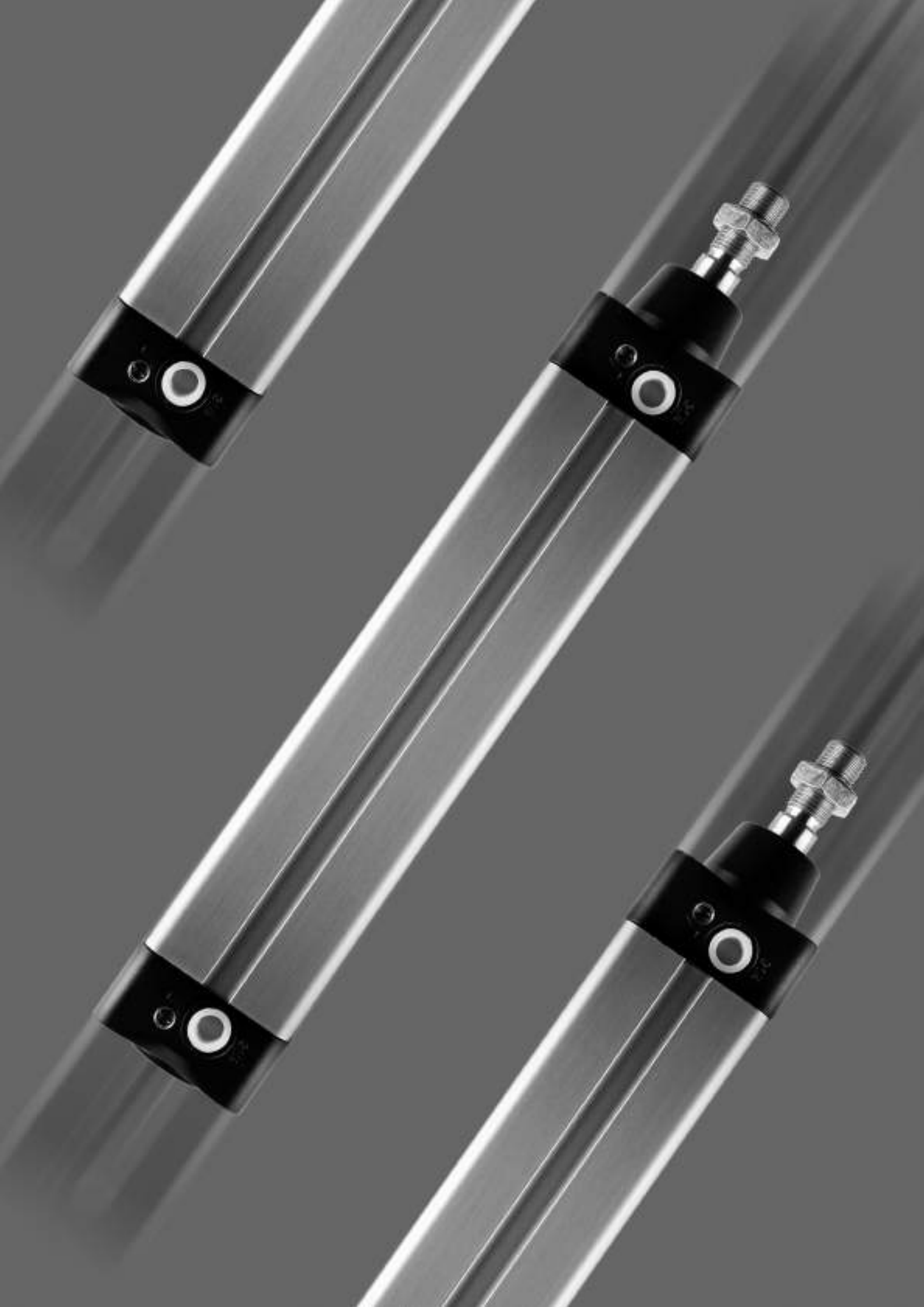

Special options	page	1.1
Series C		
Cartridge cylinders	page	1.2
Series U		
Cylinders to ISO 6432 standard.....	page	1.3
Accessories: fixings	page	1.6
piston rod locking unit series WBZ	page	1.7
guide unit series WUG	page	1.8
Series AU		
Stainless steel cylinders to ISO 6432 standard.....	page	1.12
Accessories: stainless steel fixings	page	1.14
Series P		
Round cylinders	page	1.15
Accessories: stainless steel fixings	page	1.17
Series AP		
Stainless steel round cylinders	page	1.18
Accessories: stainless steel fixings	page	1.20
Series X		
“Clean profile” cylinders to ISO 15552 standard $\varnothing 32 \div 100$	page	1.21
Accessories: cover strips and fixing brackets.....	page	1.24
Series XT		
“Mickey Mouse” profile with TEE-slot cylinders to ISO 15552 standard $\varnothing 32 \div 100$	page	1.25
Series XL		
Tie rods cylinders to ISO 15552 standard $\varnothing 125 \div 320$	page	1.29
Low friction cylinders to ISO 15552 standard $\varnothing 32 \div 200$	page	1.32
Accessories (X-XT-XL): Fixings CPUI $\varnothing 32 \div 320$	page	1.33
Piston rod locking unit for cylinder WBZ $\varnothing 32 \div 125$	page	1.38
Guide unit for cylinder WUG $\varnothing 32 \div 63$	page	1.39
Hydraulic speed regulators HS	page	1.43
Series AX		
Stainless steel cylinders to ISO 15552 standard.....	page	1.50
Accessories: stainless steel fixings	page	1.52
Series CX-CXL		
Cylinders to AFNOR NF E49-001 (ex CNOMO) standard	page	1.57
Accessories: fixings	page	1.60
Series CPU		
Cylinders to ex CETOP RP 43 P standard	page	1.63
Accessories: fixings	page	1.65
Series BX		
Compact cylinders to ISO 21287 standard.....	page	1.67
Accessories: fixings	page	1.71
Series ABX		
Stainless steel compact cylinders to ISO 21287 standard.....	page	1.72
Series BU		
Compact cylinders to AFNOR NF E49-004-1 and NF E49-004-2 standards.....	page	1.75
Accessories: fixings	page	1.79
Series B		
Compact cylinders	page	1.81
Accessories: fixings	page	1.87
Series BG		
Compact guided cylinders	page	1.88
Series CPA		
Twin rod cylinders	page	1.91
Accessories: fixings	page	1.93
Series WR		
Rotary cylinders	page	1.94
Series Z		
Rodless cylinders	page	1.96
Accessories: fixings	page	1.101
Series HB		
Screwed-head cylinders.....	page	1.102
Series F		
Cylinders piston rod attachments	page	1.108
Series FM		
Magnetic sensors for cylinders FM100 - FM101 - FM157 - FM100/EX.....	page	1.111

SPECIAL OPTIONS TABLE FOR CYLINDERS

	C	U	AU	P	AP	X-XT	XL	AX	CX-CXL	CPU	BX	ABX	BU	B	BG	CPA	WR	Z	HB
S																			
S0																			
S2																			
S3											As standard	As standard	As standard	As standard					
S4								As standard				As standard							
S5						As standard	As standard	As standard		As standard						As standard	As standard		
S6																			
S8																			
S9	As standard	As standard	As standard	As standard	As standard	As standard	As standard	As standard	As standard	As standard	As standard	As standard	As standard	As standard					
S10	As standard	As standard	As standard	As standard	As standard						As standard	As standard	As standard	As standard					As standard
S10A																			
S10B																			
S12																			
S14									As standard	As standard									
S15A									As standard										
S15B									As standard										

Feasible Not feasible

- S - WAIRCOM M.B.S. drawing
- S0 - Metallic scraper
- S2 - Scraper ring for high temperatures (for U series supplied from Ø 12 to Ø 25)
- S3 - Female threaded piston rod (AF=1,5KF)
- S4 - End caps screws, nuts and tie rods made of stainless steel
- S5 - Female threaded tie rods
- S6 - Completed threaded and galvanized tie rods
- S8 - Through rod with different piston rod for side "B" and/or "C"
- S9 - Piston rod with plane working for key
- S10 - Without cushioning (aluminium piston only)
- S10A - With front cushioning (aluminium piston only)
- S10B - With rear cushioning (aluminium piston only)
- S12 - Single acting with bidirectional piston seal
- S14 - Round tube with external tie rods to mount XT/CT Ø and XT/CPU/CT Ø
- S15A - Front protruding tie rods (for option S14)
- S15B - Rear protruding tie rods (for option S14)

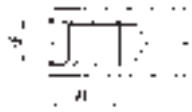

Ø Piston rod	10	12	16	20	25	32	40	50	63
KF	M6	M8	M10	M12	M16	M16	M20	M24	M30

Example: Cylinder to ISO 15552 standards Ø 63, through rod, 150 mm stroke, magnetic piston type with different piston rod on side "B" with dimensions: KK=M20x1,5 AM=45 and WH=60: 63R150 XT/M S8 B KK=M20x1,5 AM=45 WH=60

1

DESCRIPTION

The single acting front spring cartridge micro-cylinders are available in three bores, each bore in three strokes and in two versions: threaded or non-threaded piston rod. They are used in applications where a must is to have extremely small actuators. The thread on cylinders barrel helps the assembling directly on the industrial machines. They can comply with ATEX directive, 2GD category, upon request.



TECHNICAL DATA

Operating pressure	2 ÷ 6 bar
Working temperature	Ø 6 = 0 ÷ +80 °C (with dry air -20 °C) Ø 10-16 = 0 ÷ +80 °C (with dry air -35 °C)
Fluid	Compressed air, filtered, continuous lubricated, unlubricated or dry lubricated
Versions	Single acting front spring
Bore	Ø 6, 10, 16,
Port size	Ø 6 ÷ 16 = M5
Standard strokes (mm)	5, 10, 15
Spring theoretical tractive force	See technical data on page 0.13

MATERIALS

Body	Nichel-plated brass
Piston rod	AISI 303 stainless steel
Rod and end cap nuts	Galvanized steel
Piston	Ø 6 - 10 = AISI 303 stainless steel Ø 16 = Brass
Seals	Ø 6 = NBR Ø 10 - 16 = Polyurethane
Spring	Springs steel

ORDER KEY

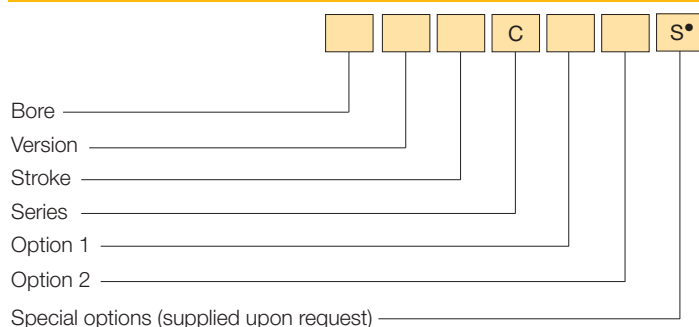

• See chapter 1, page 1.1.

VERSION 1

/ Single acting front spring

OPTION 1

L Smooth piston rod F Threaded piston rod

OPTION 2

/EX Consistent with the ATEX directive II 2GD c T5 T100°C - 10°C < Ta < 80°C

ORDER EXAMPLES

Cylinder Ø 6, single acting front spring, 15 mm stroke, smooth piston rod: **6/15 CL**

Cylinder Ø 16, single acting front spring, 10 mm stroke, threaded piston rod: **16/10 CF**

C BASIC CYLINDER

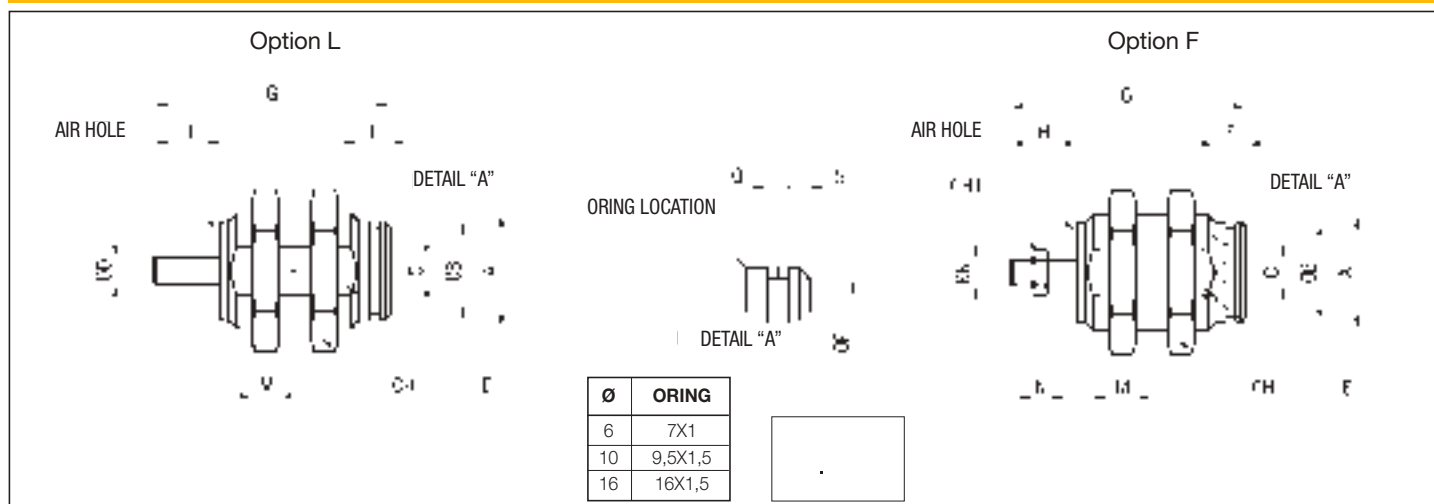

P.S.: **ORING** no supplied as standard

DIMENSIONS AND WEIGHTS BASIC CYLINDER

Ø	A	B	C	CH	CH1	D	E	F	G			H	KK	M	N	P	Q	S	WEIGHT (g)		
									5 mm	10 mm	15 mm								5 mm	10 mm	15 mm
6	M10X1	8,5	M5	14	5,5	3	9	5	27,5	34,5	41,5	8	M3	3	2,4	7,2	1,2	1,5	13	16	19
10	M15X1,5	12	M5	19	7	4	14	7	33,5	40	47	10,5	M4	4	3,2	9,8	2	1,5	30	34,5	41
16	M22X1,5	19	M5	27	8	5	20	6	40	45	50	13	M5	5	4	16,8	2	2	77	84	91,5

DESCRIPTION

Cylinders series "U" and their accessories, comply with ISO 6432 standard, are available: in basic version, with through rod and rear axial feed, magnetic or non-magnetic and with adjustable cushions. They can comply with ATEX directive, 2GD category, upon request.



TECHNICAL DATA

Operating pressure	1 ÷ 10 bar
Working temperature	0 ÷ +80 °C (with dry air -20 °C) 0 ÷ +150 °C with seal for high temperature (with dry air -10 °C)
Fluid	Compressed air, filtered, continuous lubricated, unlubricated or dry lubricated
Versions	Double acting, single acting front spring, single acting rear spring, through rod, Flat rear cap (rear axial feed)
Bore	Ø 8, 10, 12, 16, 20, 25
Port size	Ø 8 ÷ 16 = M5 Ø 20 - 25 = G1/8
Standard strokes (mm)	10, 15, 20, 25, 30, 40, 50, 60, 70, 80, 90, 100, 120, 125, 140, 150, 160, 180, 200, 250, 300, 350, 400, 500
Decelerators length	Ø 16 20 25 mm 17 18 18.5
Maximum strokes (mm)	Ø 8 - 10 = 150; Ø 12 - 16 = 250; Ø 20 - 25 = 1000
Max. stroke single acting (mm)	Ø 8 ÷ 12 = 20; Ø 16 ÷ 25 = 50
Spring theoretical tractive force	See technical data on page 0.13

MATERIALS

End caps	Anodized aluminium alloy
Cylinder barrel	Extruded tube, AISI 304 stainless steel
Barrel-end cover fixing type	Irreversible calking with dual-seal system, mechanical and pneumatic
Piston rod	AISI 303 rolled stainless steel
Rod and end cap nuts	Steel Stainless steel (supplied upon request)
Decelerators ogives	Brass
Piston rod bearing	Self-lubricating sintered bronze
Piston	Aluminium alloy with acetal resin piston bearing (supplied with and without magnet)
Piston seals	NBR rubber - FKM (Viton®)
Springs	Springs steel

ORDER KEY

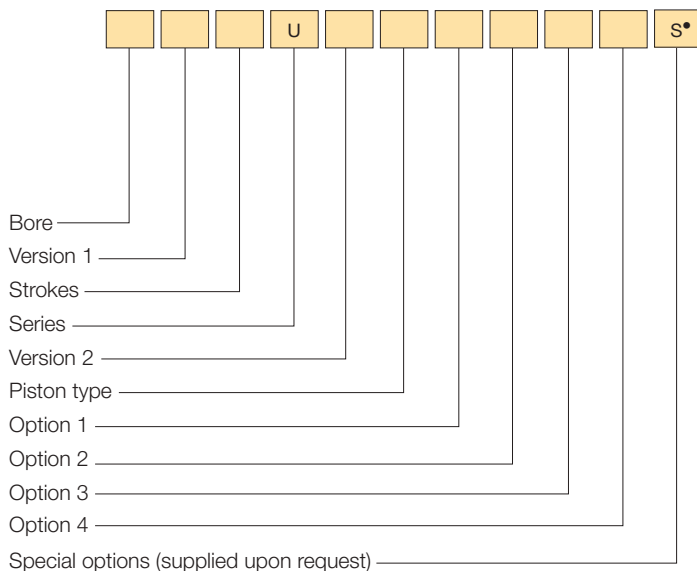

• See chapter 1, page 1.1.

VERSION 1

/ Basic cylinder **R** Through rod
H Flat rear cap with rear axial feed (non-cushioned)*

VERSION 2

D Double acting **Y** Single acting rear spring**
S Single acting front spring

PISTON TYPE

C Non-magnetic **E** Magnetic***

OPTION 1

X Cushioned****

OPTION 2

Z Fit for piston rod locking unit*****

OPTION 3

2 Seals for high temperatures*

OPTION 4

/EX Consistent with the ATEX directive II 2GD c T5 T100°C - 20°C < Ta < 80°C

* Supplied from Ø 12 to Ø 25.

** Dimensions "XC" for version "YE" is increased of 10 mm

*** Available even with "FKM" (Viton®) seals but just for applications where is needed a chemical compatibility; not available for high temperatures.

**** Supplied from Ø 16 to Ø 25.

***** Supplied only for Ø 20 and Ø 25, don't use it for high temperature application.

ORDER EXAMPLES

Basic cylinder Ø 16, 50 mm stroke, double acting, non-magnetic piston type: **16/50 UDC**

Basic cylinder Ø 20, 50 mm stroke, double acting, magnetic piston type, cushioned: **20/50 UDEX**

Cylinder Ø 25, through rod, 100 mm stroke, double acting, magnetic piston type, cushioned: **25R100 UDEX/EX**

Basic cylinder Ø 25, 40 mm stroke, single acting rear spring, non-magnetic piston type, seals for high temperatures: **25/40 UYC2**

1

U BASIC CYLINDER

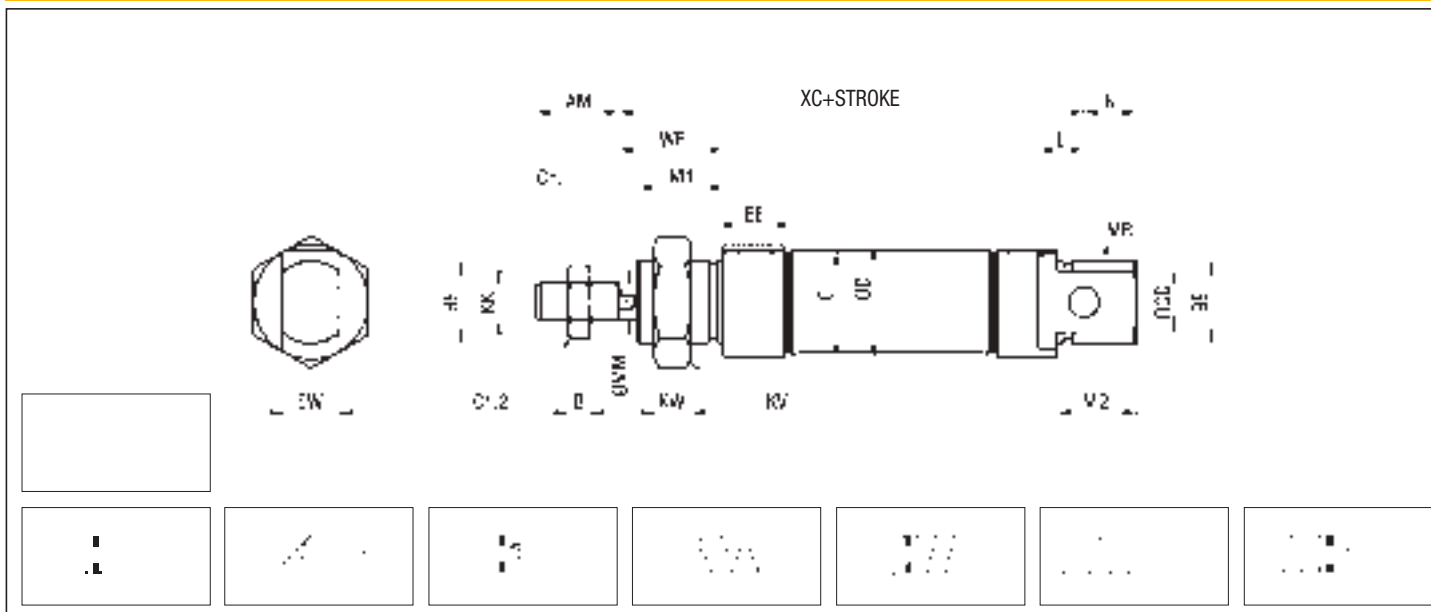

P.S.: End cap nut and rod nut supplied as standard

DIMENSIONS AND WEIGHTS BASIC CYLINDER

Ø	AM*	B	BE*	C	CD* H9	Ch	Ch2	D*	EE*	ES	EW* d13	KK	KV	KW*	L*	LB	M1	M2	MM	MR*	N	WB	WF*	XC*	WEIGHT (g)	INCR. (g) x 10 mm
8	12	3	M12x1,25	15	4	-	7	16	M5	-	8	M4	19	6	6	60	14	12	4	9	8	-	16	64	28,3	2
10	12	3	M12x1,25	15	4	-	7	16	M5	-	8	M4	19	6	6	60	14	12	4	9	8	-	16	64	29,2	2,3
12	16	4	M16x1,5	18	6	5	10	19	M5	-	12	M6	24	8	9	70	18	18	6	12	12	-	22	75	55,3	3,7
16	16	4	M16x1,5	18	6	5	10	21	M5	6	12	M6	24	8	9	77	18	18	6	12	12	-	22	82	63	4,2
20	20	5	M22x1,5	25	8	7	13	26	G 1/8	8	16	M8	30	10	12	91	19	20	8	15	13	71	24	95	138	9,1
25	22	6	M22x1,5	28,5	8	9	17	30	G 1/8	10	16	M10x1,25	30	10	12	100	23	22	10	18	15	73	28	104	188,5	12,5

* STANDARD DIMENSIONS

▲ Dimension "XC" for version "YE" is increased of 10 mm

THROUGH ROD

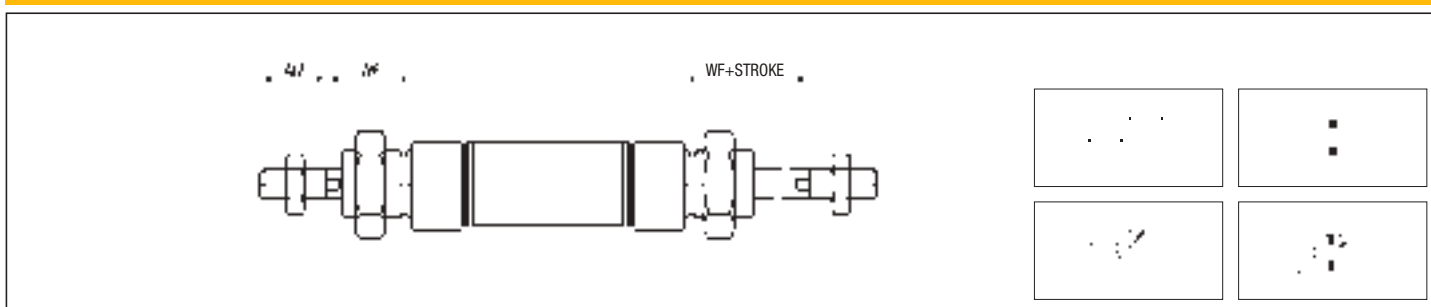

P.S.: End cap nut and rod nut supplied as standard

FLAT END CAP REAR AXIAL FEED (NOT INDICATED IN THE ISO 6432 STANDARD)

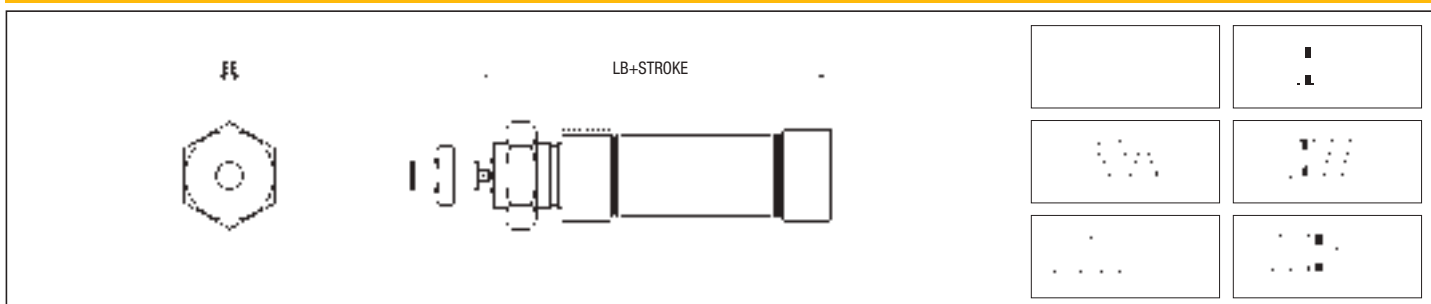

P.S.: End cap nut and rod nut supplied as standard

FIT FOR PISTON ROD LOCKING UNIT

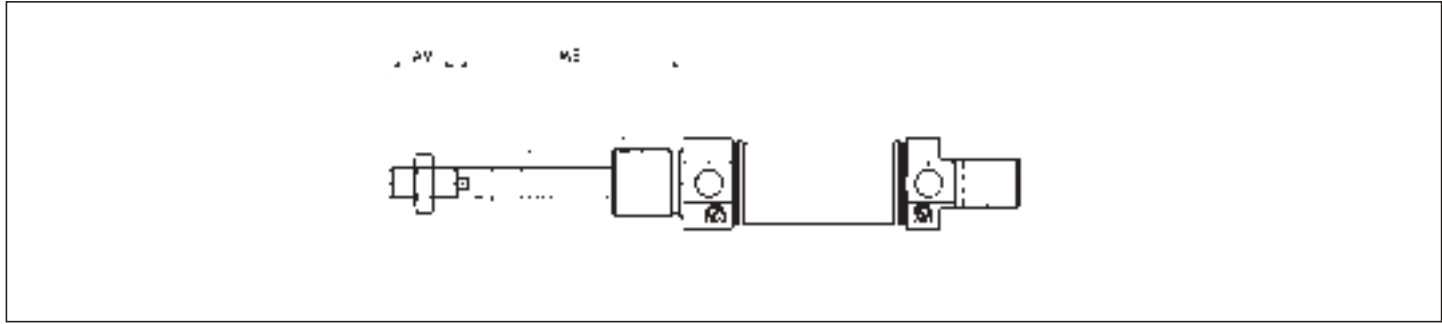

P.S.: End cap nut and rod nut supplied as standard

END CAP NUT - STEEL - UDT Ø

Ø	DI	CH	S	WEIGHT (g)
8-10	M12x1,25	19	6	7
12-16	M16x1,5	24	8	16
20-25	M22x1,5	30	10	25

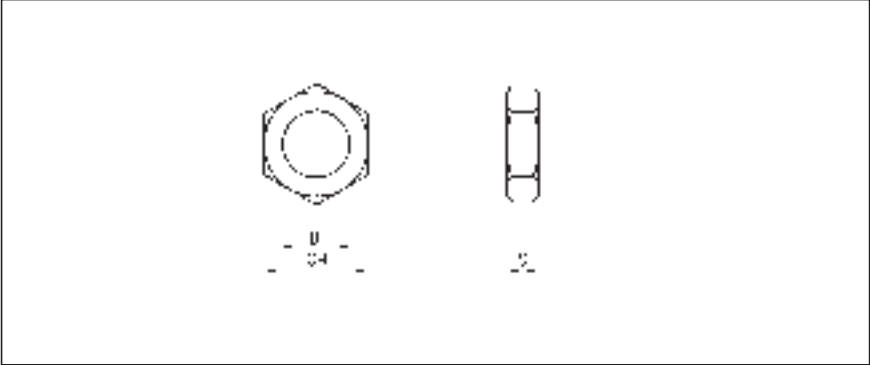

1

FLANGE - STEEL -UF Ø

Ø	FB H13	LW	S	TF JS13	UF	UR	WEIGHT (g)
8-10	4,5	13	3	30	39	19	12
12-16	5,5	18	4	40	54	30	26
20-25	6,6	19-23	5	50	64	36	50

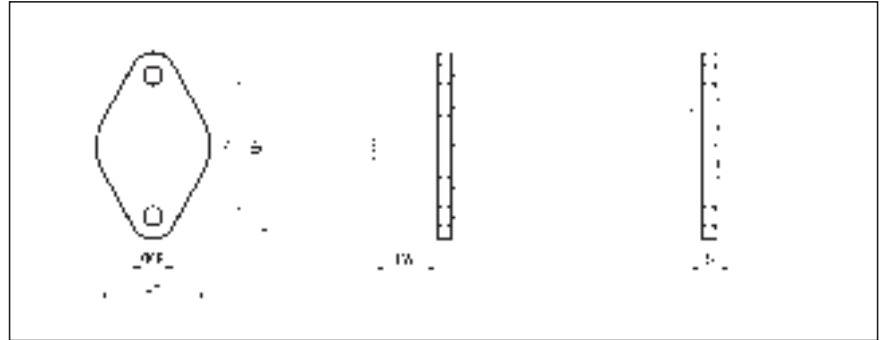

FOOT - STEEL - UP Ø

Ø	AB H13	AU	LA	LB	LC	NH	R
8-10	4,5	11	16	64	28	16	10
12-16	5,5	14	20	74-81	28-35	20	13
20-25	6,6	17	25	91-95	45,5	25	20

Ø	S	TR JS13	US	XS	XT	WEIGHT (g)
8-10	3	25	35	24	6,5	20
12-16	4	32	42	32	10	40
20-25	5	40	54	35-39	11-15	90

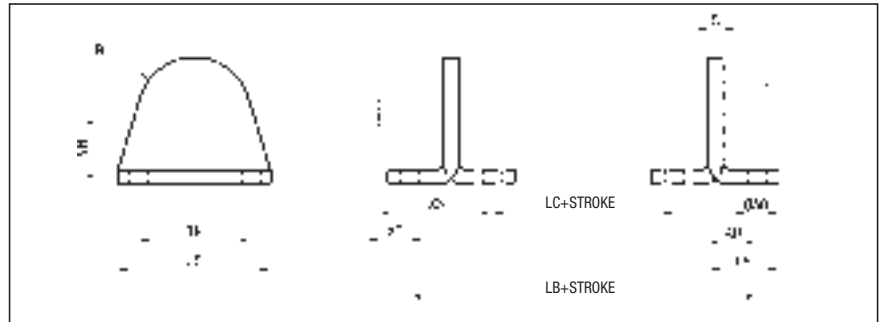

REAR HINGE NOT CONFORM TO ISO 6432 STANDARD - STEEL - USC Ø

Ø	CD f8	D H13	H	LA	LB JS13	LC E9	LD
8-10	4	4,5	24	22	12,5	8,1	3,75
12-16	6	5,5	27	25	15	12,1	5
20-25	8	6,5	25	35	18	16,1	8,5

Ø	LE	LX	R	S	WEIGHT (g)
8-10	18	62,5	5	1,5	20
12-16	24	73-80	7	1,5	36
20-25	26	97,5-106,5	8	4	50

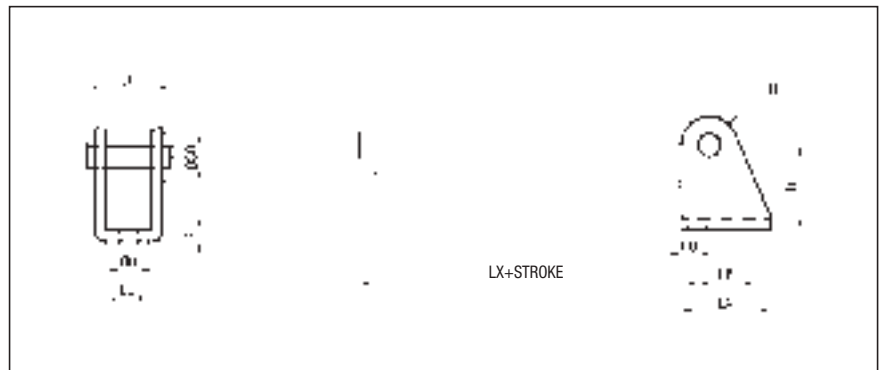

FLOATING HINGE NOT CONFORM TO ISO 6432 STANDARD - STEEL - UCT Ø

Ø	LA	LB	TD	TL	TM	UW	WEIGHT (g)
8-10	13	64	4	6	26	20	18
12-16	14	76-83	6	10	38	25	35
20-25	20-24	93-101	6	10	46	30	45

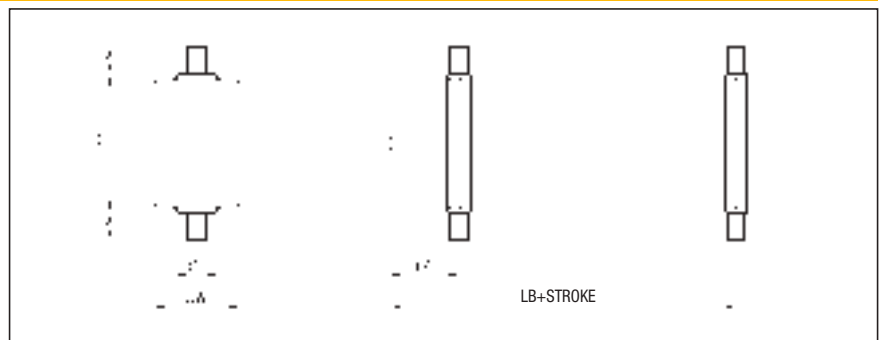

DESCRIPTION

Piston rod locking unit series "WBZ" is a mechanical device to fit on ISO 6432 cylinders (series "U"); its function is to lock the piston rod in any position. This solution allows to lock the cylinder stroke each time that there's a pressure fall. Locking force is, in any case, higher than the force given off by the cylinder fed at 10 bar.

ATTENTION: It has static operation (cylinder piston rod not moving); it's necessary to preliminary stop the cylinder piston rod before proceeding with mechanical locking. It is possible to unblock the rod lock only if the forces in the piston are balanced, otherwise there can be accidents due to the irregular movement of the rod. If the given blocking values are exceeded there can be a sliding on the rod. When it is blocked and the loads are variable on the rod, the rod can have a slight axial play. Piston rod locking unit series "WBZ" must not be considered as a safety device.



TECHNICAL DATA

Operating pressure	3 ÷ 6 bar with cylinder feed pressure 1 ÷ 10 bar
Working temperature	0 ÷ +80 °C (-5 °C with dry air)
Fluid	Compressed air, filtered, continuous lubricated, unlubricated or dry lubricated
Size	20, 25
Port size	20 - 25 = M5
Locking type	Mechanical - Only axial (bi-directional)
Release	Through pneumatic control
Condition in absence of pressure	Locked
Locking force with static load	Size 20 25 N 490 490

MATERIALS

Body	Anodized aluminium alloy
Blades	Brass
Pistons	Acetal resin
Seals	NBR rubber
Springs	Steel

ORDER KEY

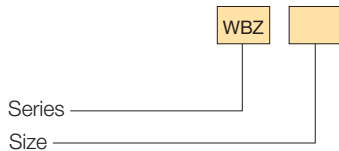

ORDER EXAMPLES

Piston rod locking unit, size 20: **WBZ20**

Piston rod locking unit, size 25 + cylinder series "U" Ø 25, fit for piston rod locking unit, 150 mm stroke, double acting, non-magnetic piston type, ASSEMBLED: **WBZ25 + 25/150 UDCZ + M/WBZ**

ASSEMBLY

WBZ + cylinders series U, Z version	M/WBZ
-------------------------------------	--------------

SPARE PARTS

BLADES KIT	Size /PM/WBZ
PISTON KIT	Size /SG/WBZ

TECHNICAL INFORMATION

"WBZ" operation is based on the action of two opposed blades. When these blades are opened up by suitably loaded springs, they oppose the sliding movement of the piston rod passing through them. It is advisable to balance the pressure in the cylinder chambers during piston rod locking phase in order to increase its working life with a 5/3 pressure centre valve (see the schemes here below).

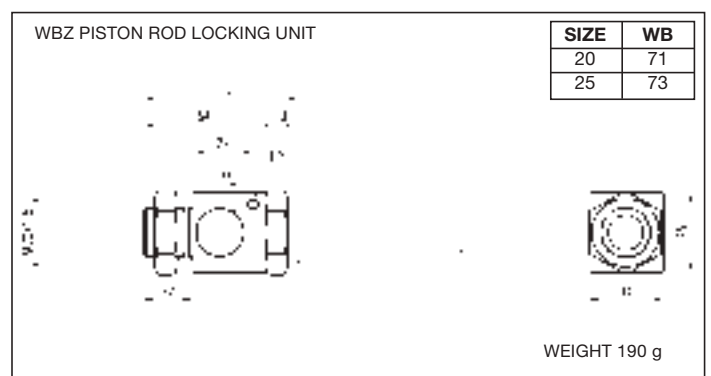
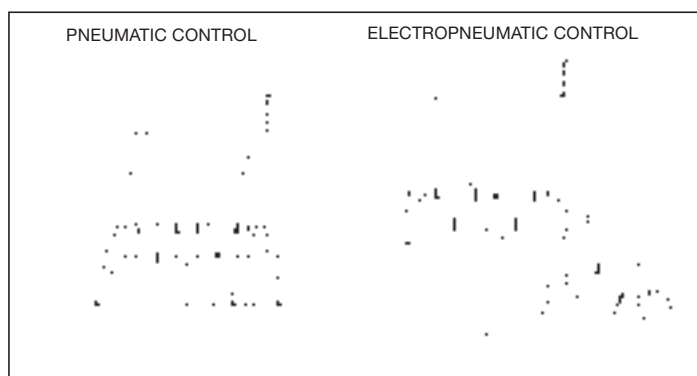

TECHNICAL INFORMATION

WUG SINGLE GUIDE UNIT

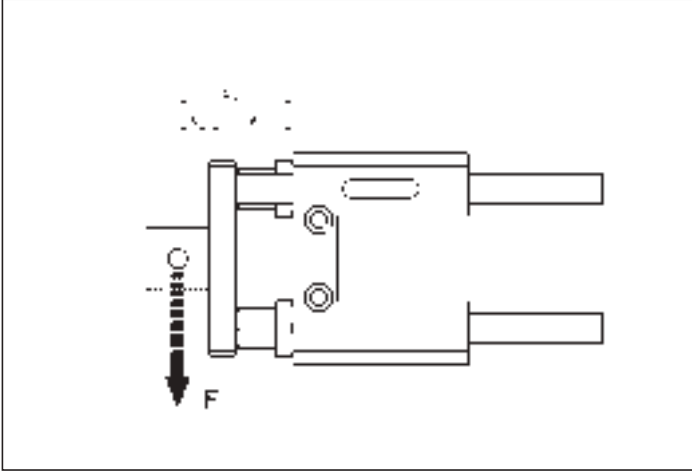

WUGD DOUBLE GUIDE UNIT

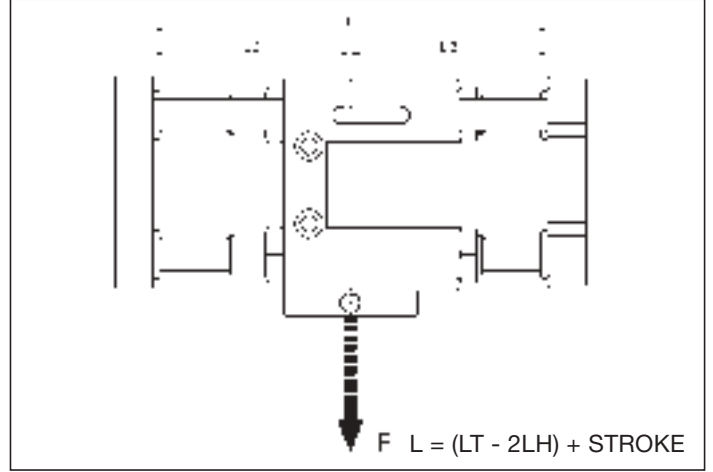

MAXIMUM PERMISSIBLE LOAD-WUG VERSION B

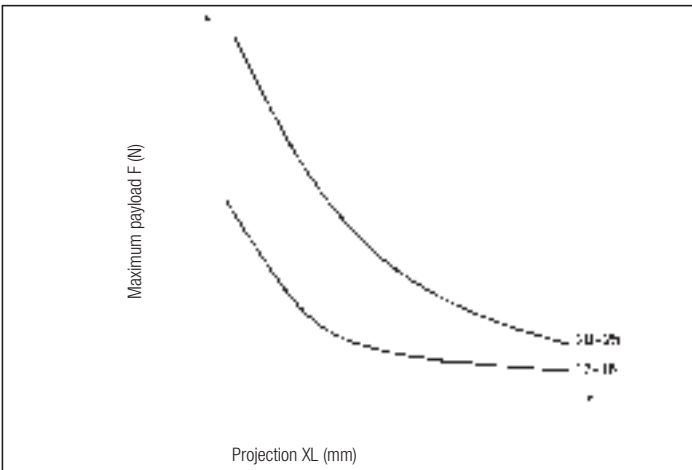

MAXIMUM PERMISSIBLE LOAD-WUGD VERSION B

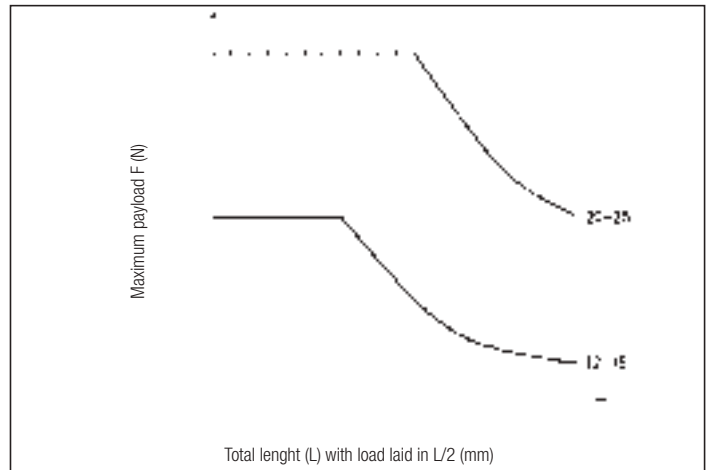

MAXIMUM PERMISSIBLE LOAD-WUG VERSION M

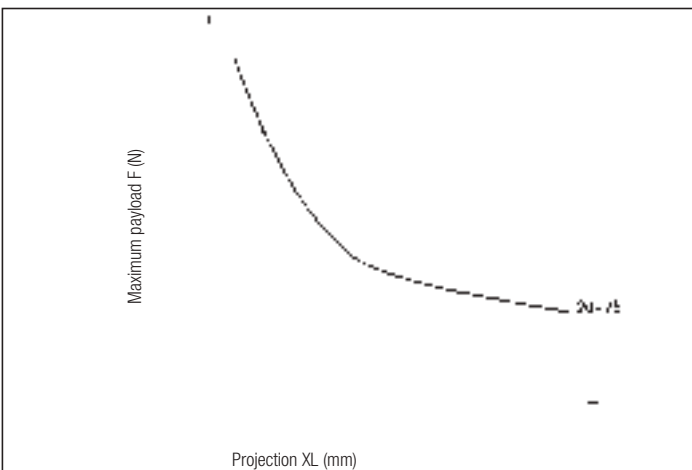

MAXIMUM PERMISSIBLE LOAD-WUGD VERSION M

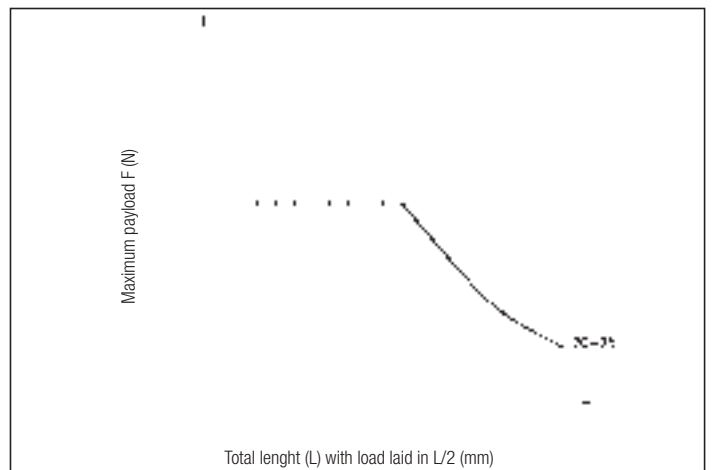

1

WUG SINGLE GUIDE UNIT

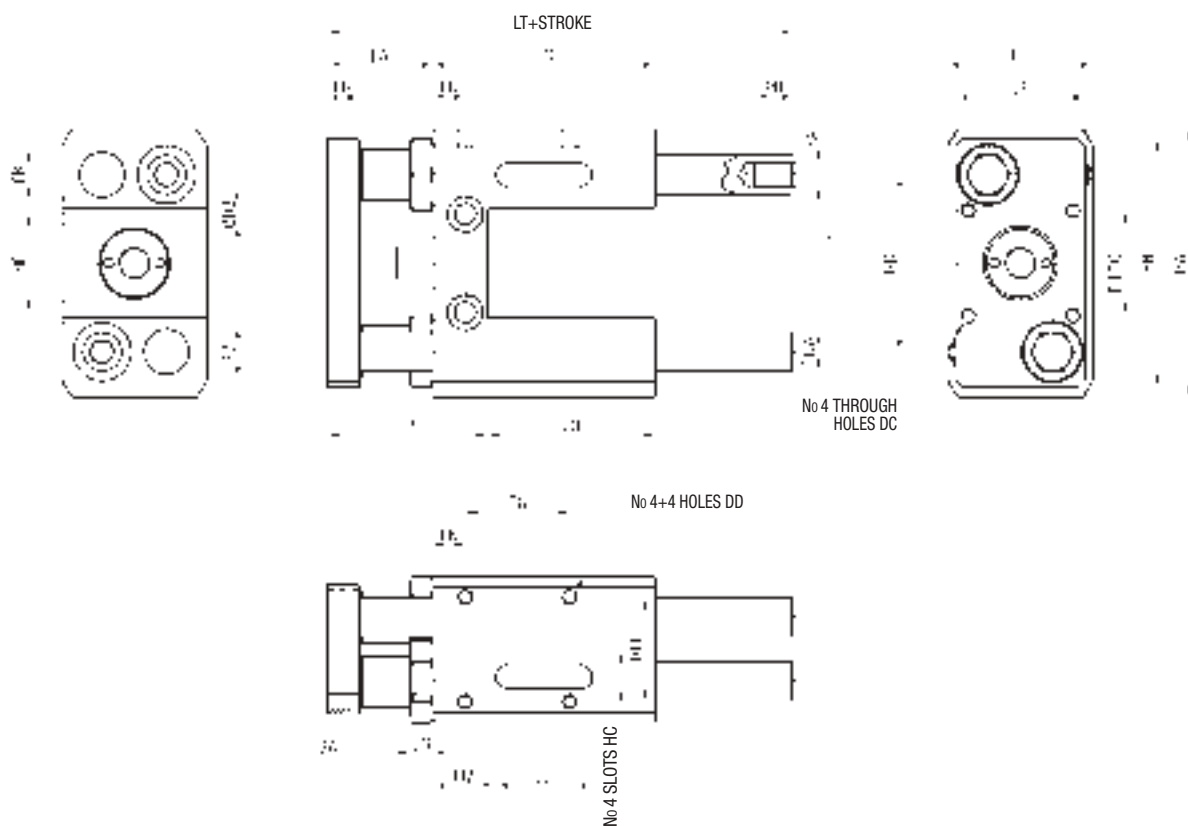

DIMENSIONS AND WEIGHTS

SIZE	DA	DB	DC	DD	FA		FB	HA	HB	HC	HD	HE	HM	LA	LB	LC	LD	LE	LF	LG	LH
12-16	10	5,2	M4	M5	M6		M12x1,25	65	60	6	47	24	32,5	25	38	60	47	40	35	7	10
20	B12 M10	6,5	M4	M5	BM8 MM6		M16x1,5	83	77	7	55	30,5	32,5	27	44	69	52	45	40	7	10
25	B12 M10	6,5	M4	M5	BM8 MM6		M16x1,5	83	77	7	55	30,5	32,5	32	50	69	52	45	40	7	10

SIZE	LK	LL	LM	LN	LT	PB	SA	TG	WEIGHT (g)		INCREM. (g) every 10 mm	
12-16	19	16	22	6,5	100	12	Ch.14	22	690		12	
20	10	30	19,5	10	115	12	Ch.21	32,5	B890 M830	B17 M12		
25	10	30	19,5	10	115	12	Ch.21	32,5	B890 M830	B17 M12		

B - Bushings

M - Sleeves

series AU

Stainless steel cylinders
to ISO 6432 standard

1

DESCRIPTION

Calked stainless steel cylinders series "AU" comply with ISO 6432 standard. They are available from Ø 16 to Ø 25, in the basic cylinder version, through rod, magnetic and non-magnetic, and in the adjustable cushions version produced from Ø 20 to Ø 25. They can comply with ATEX directive, 2GD category, upon request.



TECHNICAL DATA

Operating pressure	1 ÷ 10 bar
Working temperature	0 °C ÷ +80 °C (with dry air -35 °C) 0 °C ÷ +150 °C with seals for high temperatures (with dry air -10 °C)
Fluid	Compressed air, filtered, continuous lubricated, unlubricated or dry lubricated
Versions	Double acting, through rod
Bore	Ø 12, 16, 20, 25
Port size	Ø 12 - 16 = M5 Ø 20 - 25 = G1/8
Standard strokes (mm)	25, 50, 80, 100, 125, 160, 200, 250, 300, 320, 400, 500
Decelerators lenght	Ø 20 25 mm 18 20
Maximum strokes (mm)	Ø 12 - 16 = 200; Ø 20 = 320; Ø 25 = 500

MATERIALS

End caps	AISI 304 stainless steel
Cylinder barrel	Extruded tube, AISI 304 stainless steel
Barrel-end cover fixing type	Irreversible calking with dual-seal system, mechanical and pneumatic
Piston rod	AISI 316 stainless steel
Rod and end cap nuts	AISI 304 stainless steel
Decelerators ogives	Aluminium alloy
Piston rod bearing	Self lubricating sintered bronze
Piston	Brass (supplied with and without magnet)
Piston seals	Polyurethane - FKM (Viton®)

ORDER KEY

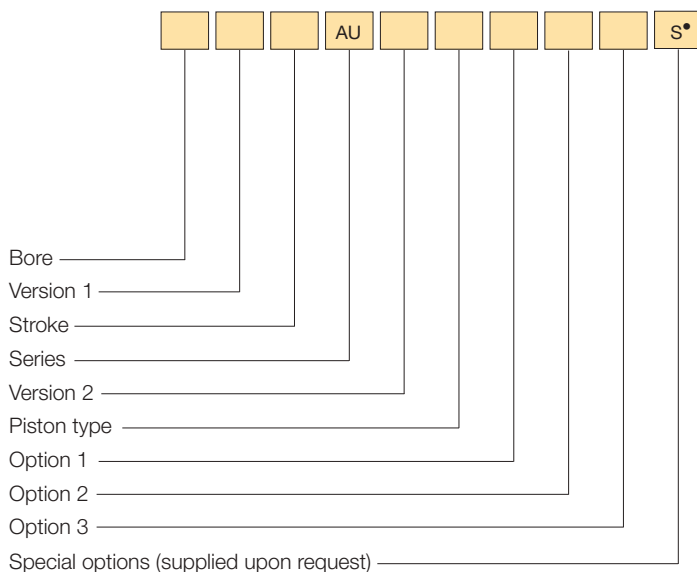

• See chapter 1, page 1.1.

VERSION 1

/ Basic cylinder R Through rod

VERSION 2

D Double acting

PISTON TYPE

C Non-magnetic E Magnetic*

OPTION 1

X Cushioned**

OPTION 2

2 Seals for high temperatures

OPTION 3

/EX Consistent with the ATEX directive  II 2GD c T5 T100°C -20°C<Ta<80°C***

* Available even with "FKM" (Viton®) seals but just for applications where is needed a chemical compatibility; not available for high temperatures.

** Supplied only for Ø 20 to Ø 25

*** Not supplied for Ø 12

ORDER EXAMPLES

Basic cylinder Ø16, 50 mm stroke, double acting, non-magnetic piston type: ATEX: **16/50 AUDC/EX**

Basic cylinder Ø20, 50 mm stroke, double acting, magnetic piston type, cushioned: **20/50 AUDCX**

Cylinder Ø25, through rod, 100 mm stroke, double acting, magnetic piston type, cushioned: **25R100 AUDEX**

AU BASIC CYLINDER

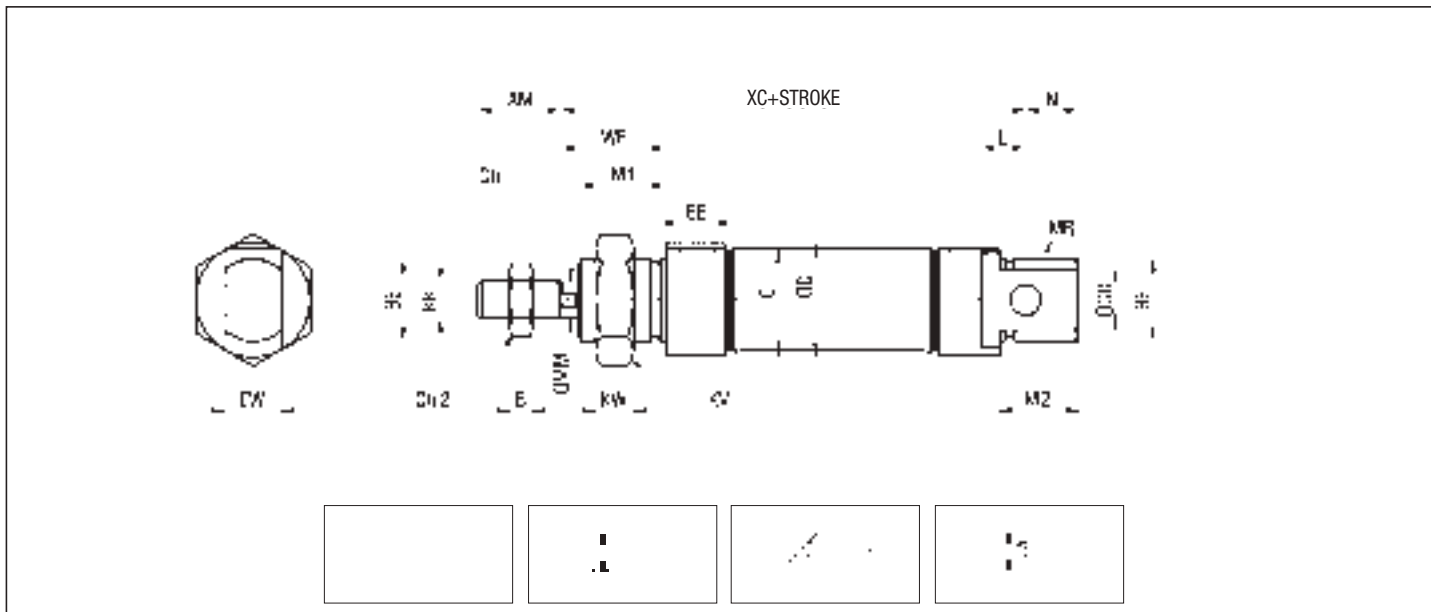

P.S.: End cap nut and nut rod supplied as standard

DIMENSIONS AND WEIGHTS BASIC CYLINDER

Ø	AM*	B	BE	C	CD* H9	Ch*	Ch2	D*	EE*	EW* d13	KK	KV	KW*	L*	M1	M2	MM	MR*	N	WF*	XC*	WEIGHT (g)	INCR (g) x 10 mm
12	16	4	M16X1,5	18	6	5	10	19	M5	12	M6	24	8	9	18	18	6	13,3	13	22	75	118	3,7
16	16	4	M16X1,5	18	6	5	10	19	M5	12	M6	24	8	9	18	18	6	13,3	11	22	82	139	4,2
20	20	5	M22X1,5	25,5	8	7	13	27	G1/8	16	M8	32	11	12	20	20	8	18,8	16	24	95	306	9,1
25	22	6	M22X1,5	28,5	8	9	17	30	G1/8	16	M10X1,25	32	11	12	22	22	10	17,1	14	28	104	406	12,5

* STANDARDIZED DIMENSIONS

THROUGH ROD

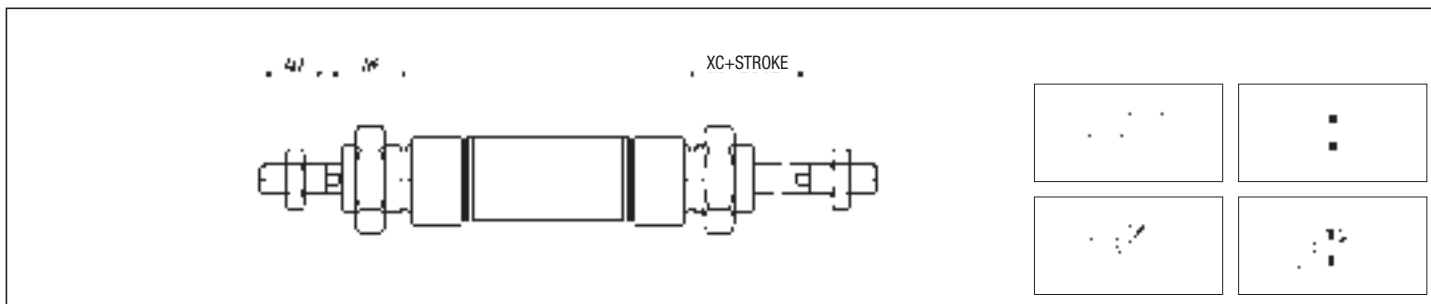

P.S.: End cap nut and nut rod supplied as standard

1

END CAP NUT - STAINLESS STEEL - AUDT Ø

Ø	DI	CH	S	WEIGHT (g)
12-16	M16x1,25	24	8	16
20-25	M22x1,5	32	11	25

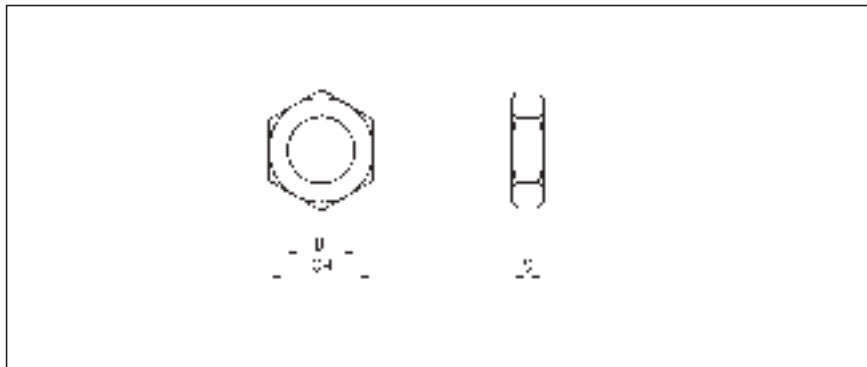

FLANGE- STAINLESS STEEL - AUF Ø

Ø	FB H13	LW	S	TF JS13	UF	UR	WEIGHT (g)
12-16	5,5	18	4	40	52	30	26
20-25	6,6	19-23	5	50	66	40	50

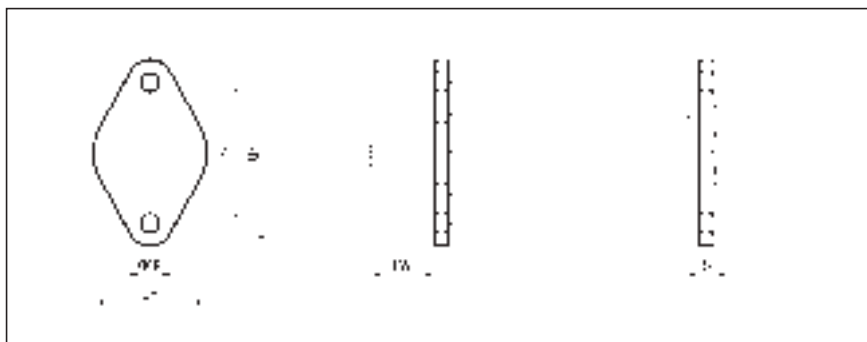

FOOT - STAINLESS STEEL - AUP Ø

Ø	AB H13	AU	LA	LB	LC	NH	R
12-16	5,5	14	20	74-81	28-35	20	12,5
20-25	6,6	17	25	91-95	45,5	25	20

Ø	S	TR JS13	US	XS	XT	WEIGHT (g)
12-16	4	32	42	32	8	40
20-25	5	40	54	36-40	7-11	90

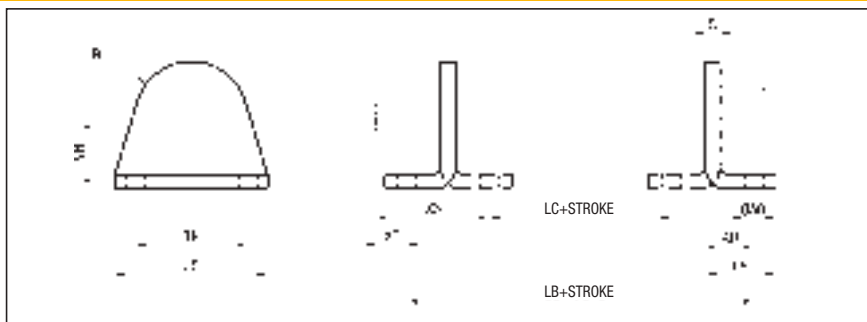

REAR HINGE NOT TO ISO 6432 STANDARD - STAINLESS STEEL - AUSC Ø

Ø	CD f8	D H13	H	LA	LB JS13	LC E9	LD
12-16	6	5,5	27	25	15	12,1	5
20-25	8	6,6	30	32	20	16,1	6

Ø	LE	LX	R	S	WEIGHT (g)
12-16	24	73-80	7	3	36
20-25	26	91-100	10	4	78

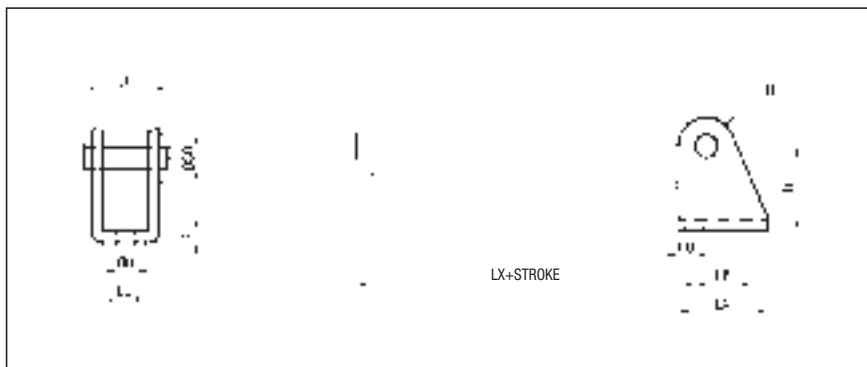

DESCRIPTION

Round profile cylinders series "P" and their accessories, are produced from Ø 32 to Ø 63, with techno-polymer piston supplied as standard, available in basic version, through rod or with rear axial feed, magnetic or non-magnetic, with adjustable cushions. They can comply with ATEX directive, 2 GD category, upon request.



TECHNICAL DATA

Operating pressure	1 ± 10 bar
Working temperature	0 ÷ +80 °C (-20 °C with dry air) 0 ÷ +150 °C with seals for high temperature (-10 °C with dry air)
Fluid	Compressed air, filtered, continuous lubricated, unlubricated or dry lubricated
Versions	Double acting, single acting front spring, single acting rear spring, through rod, flat rear cap (rear axial feed); reduced flat rear cap
Bore	Ø 32, 40, 50, 63
Port size	Ø 32 = G 1/8 Ø 40 - 50 = G 1/4 Ø 63 = G 3/8
Standard strokes (mm)	10, 25, 50, 75, 80, 100, 125, 150, 160, 175, 200, 250, 300, 320, 350, 400, 450, 500
Decelerators length	Ø 32 40 50 63 mm 29 35 40 40
Max strokes (mm)	Ø 32 ÷ 63 = 1000
Max strokes single act. (mm)	Ø 32 ÷ 63 = 50
Spring theoretical tractive force	See technical data on page 0.13

MATERIALS

End caps	Anodized aluminium alloy
Cylinder barrel	Extruded tube, AISI 304 stainless steel
Barrel-end cover fixing type	Irreversible calking with dual-seal system, mechanical and pneumatic
Piston rod	C45 chromium-plated steel AISI 303 rolled stainless steel
Rod nut and ring nut	Steel Stainless steel
Decelerator ogives	Anodized aluminium alloy
Piston rod bearing	Self lubricating sintered bronze
Piston	Techno-polymer (supplied with and without magnet) Aluminium alloy (supplied with and without magnet) for high temperature, for applications that don't provide the real use of the cushioning and strokes other 1000 mm
Piston seals	Polyurethane - FKM (Viton®)
Springs	Spring steel

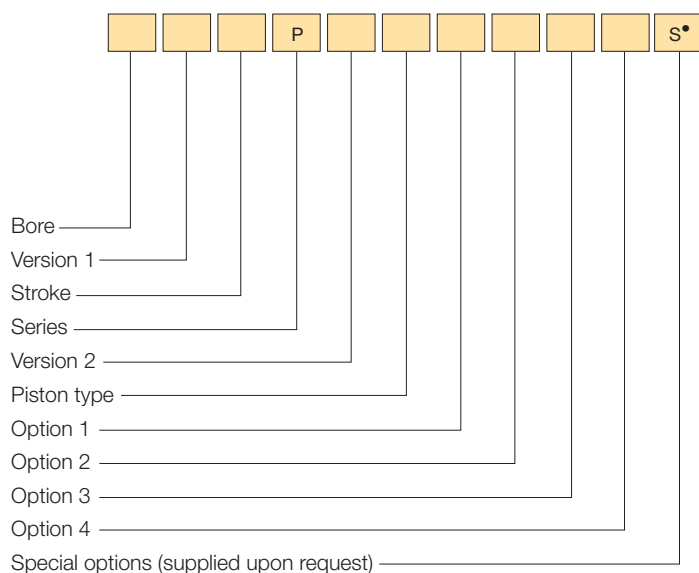

• See chapter 1, page 1.1.

VERSION 1

/ Basic cylinder	R Through rod
H Flat rear cap (rear axial feed)	C Reduced flat rear cap

VERSION 2

D Double acting	Y Single acting rear spring*
S Single acting front spring	

PISTON TYPE

C Non-magnetic	E Magnetic**
----------------	--------------

OPTION 1

X Cushioned ("H" and "C" versions excluded)

OPTION 2

1 Stainless steel piston rod and rod nut	3 Stainless steel piston rod and rod nut, and seals for high temperature***
2 Seals for high temperature***	

OPTION 3

5 Aluminium alloy piston

OPTION 4

/EX Consistent with the ATEX directive  II 2GD c T5 T100°C -20°C < Ta < 80°C

* Different dimensions from the versions "D" and "S"; contact the commercial office
 ** Available even with "FKM" (Viton®) seals but just for applications where is needed a chemical compatibility; not available for high temperatures.
 *** Supplied only with non-magnetic piston type.

ORDER EXAMPLES

Basic cylinder Ø 32, 50 mm stroke, double acting, non magnetic piston type: **32/50 PDC**

Basic cylinder Ø 40, 50 mm stroke, double acting, magnetic piston type, cushioned: **40/50 PDE**

Cylinder Ø 50, through rod, 100 mm stroke, double acting, magnetic piston type, cushioned: **50R100 PDCX**

Basic cylinder Ø 50, 40 mm stroke, single acting rear spring, non-magnetic piston type, seals for high temperature, ATEX: **50/40 PYC2/EX**

1

P BASIC CYLINDER

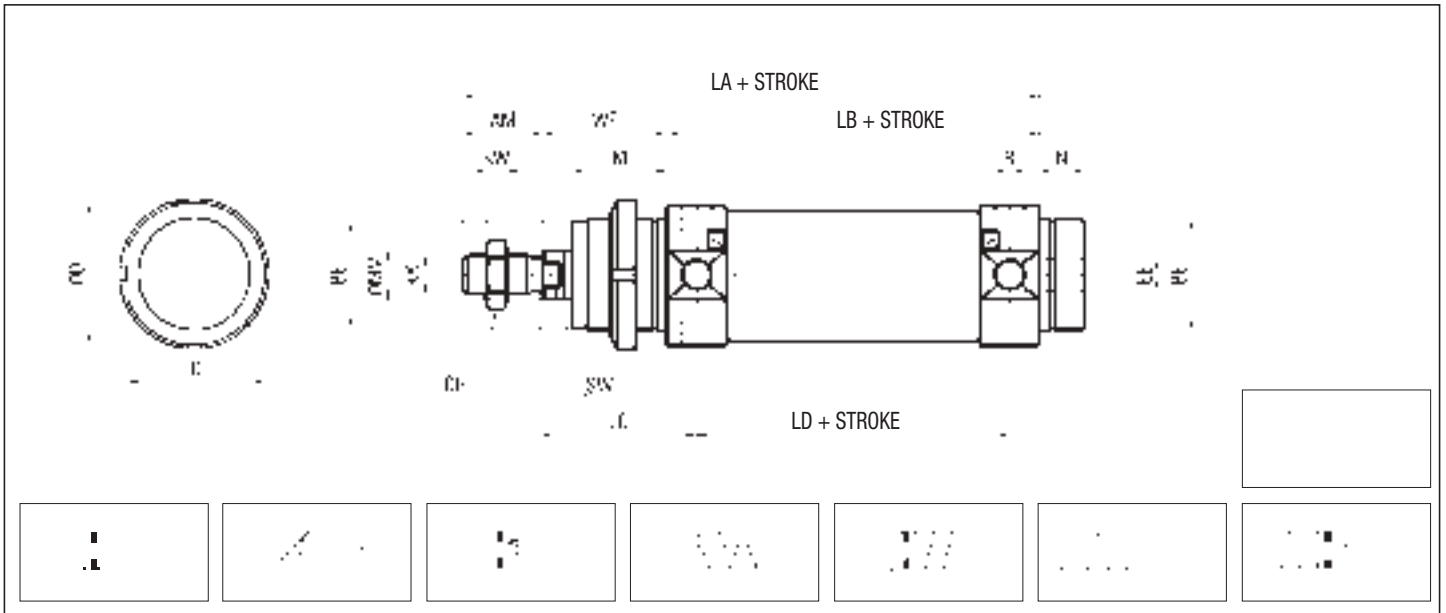

P.S.: End cap ring nut and rod nut supplied as standard

DIMENSIONS AND WEIGHTS BASIC CYLINDER

Ø	AM	BE	C	CH	D	EE	KK	KW	LA	LB	LC	LD	M	MM	N	R	SW	WF	XC	XD	WEIGHT (g)	INCR. (g) x 10 mm
32	20	M30x1,5	36,5	17	38	G1/8	M10x1,25	6	154	96	47	78	30	12	14	M8x1	10	38	134	140	386	16
40	24	M38x1,5	44	19	46	G1/4	M12x1,25	7	182	113	57	89	35	16	16	M10x1	12	45	158	163	690	26
50	32	M45x1,5	55	24	57	G1/4	M16x1,5	8	202	120	62	96	38	20	18	M12x1,5	16	50	170	176	1265	34
63	32	M45x1,5	67,5	24	70	G3/8	M16x1,5	8	206	124	63	98	38	20	18	M14x1,5	16	50	174	180	1750	50

THROUGH ROD

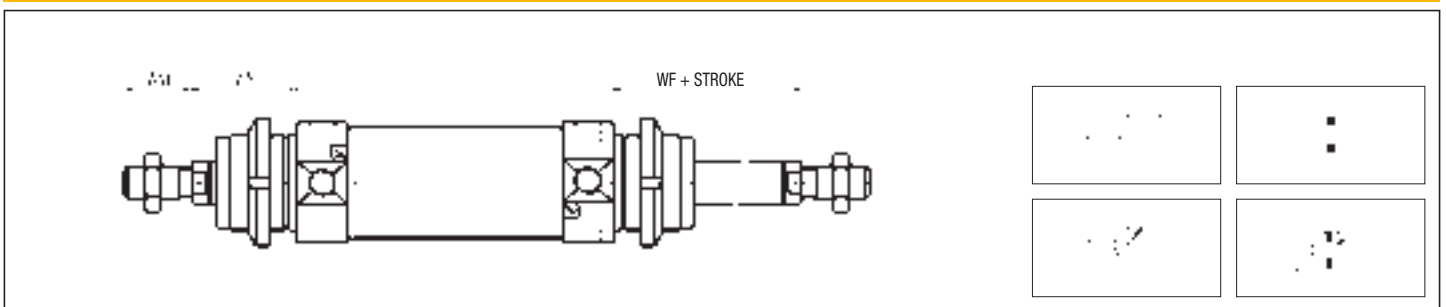

P.S.: End cap ring nut and rod nut supplied as standard

FLAT END CAP (REAR AXIAL FEED)

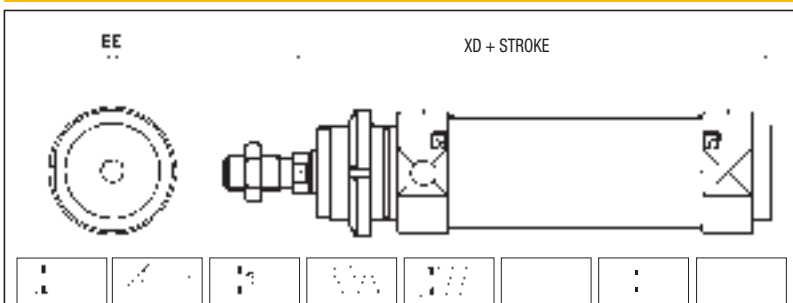

P.S.: End cap ring nut and rod nut supplied as standard

REDUCED FLAT REAR CAP

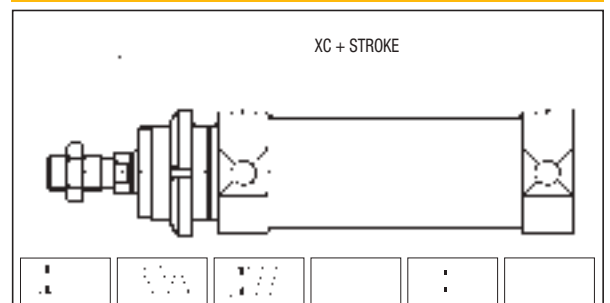

P.S.: End cap ring nut and rod nut supplied as standard

RING NUT - STEEL - PG Ø

Ø	d	D	S	WEIGHT (g)
32	M30x1,5	42	8	43
40	M38x1,5	50	10	80
50-63	M45x1,5	65	10	122

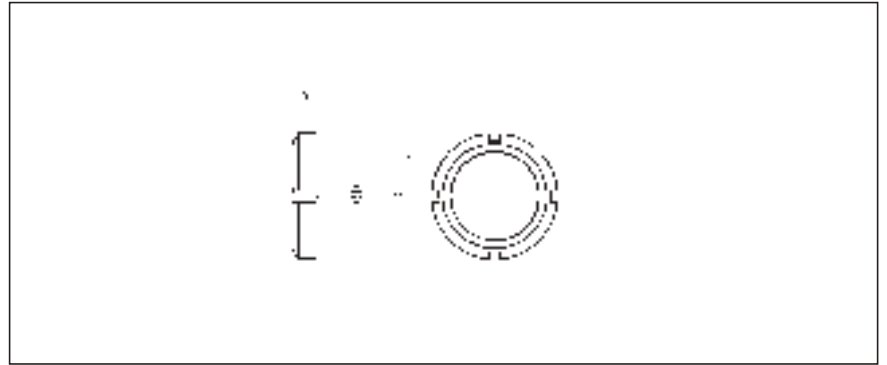

FLANGE/FOOT - STEEL - PFP Ø

Ø	AB	AU	HA	HB	HC	LA	LB	LC
32	7	14	14	49	28	21	124	76
40	9	20	18	58	30	30	153	83
50	9	20	20	70	40	30	160	92
63	9	20	20	80	50	30	164	92

Ø	NH	S	TB	TR	TS	XS	XT	WEIGHT (g)
32	28	4	11	52	66	48	24	98
40	33	5	13	60	80	60	25	183
50	40	6	14	70	90	64	30	276
63	45	6	14	76	96	64	30	395

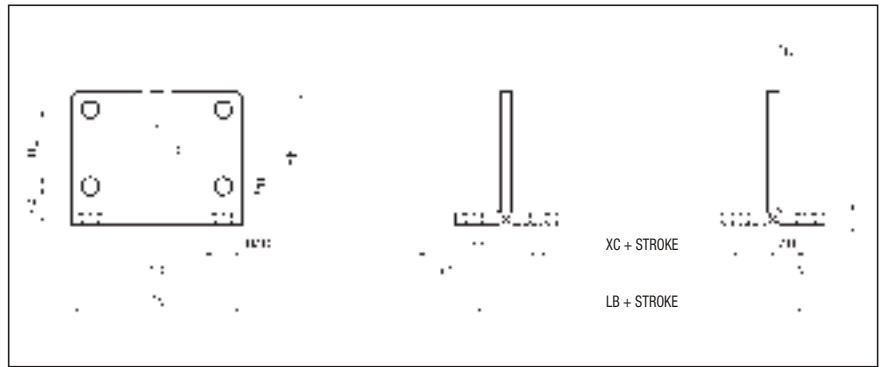

REAR HINGE - STEEL - PSC Ø

Ø	CH	E	G	H	L	LA	LB
32	13	7	20	35	125	20	46,1
40	17	9	27	40	146	28	56,1
50	19	9	30	45	158	36	69,1
63	19	9	34	50	161	42	82,1

Ø	LC	NA	NB	R	S	WEIGHT (g)
32	58	24	40	12	4	150
40	70	30	50	13	5	259
50	86	34	54	14	6	403
63	100	35	65	16	6	520

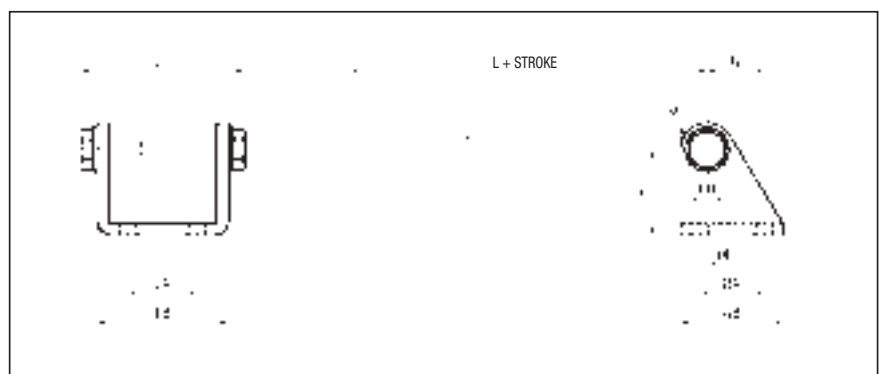

PIVOT (PAIR) - STEEL - PT Ø

Ø	D	H	LA	LB	CH	WEIGHT (g)
32	10	51	47	125	5	10
40	12	61	57	146	6	20
50	14	75	62	158	6	40
63	16	92	63	161	8	65

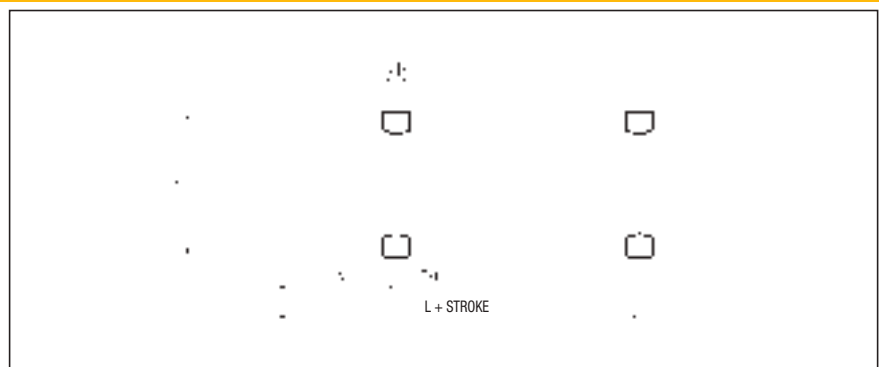

1

DESCRIPTION

Stainless steel cylinders serie "AP" with round profile, and correspondent fixings accessories, are available from Ø 32 to Ø 63, in the basic cylinder version, through rod, magnetic and non-magnetic. They can comply with ATEX directive, 2GD category, upon request.



TECHNICAL DATA

Operating pressure	1 ± 10 bar
Working temperature	0 ÷ +80 °C (-20 °C with dry air) 0 ÷ +150 °C with seals for high temperature (-10 °C with dry air)
Fluid	Compressed air, filtered, continuous lubricated, unlubricated or dry lubricated
Versions	Double acting, through rod
Bore	Ø 32, 40, 50, 63
Port size	Ø 32 = G 1/8 Ø 40 - 50 = G 1/4 Ø 63 = G 3/8
Standard strokes (mm)	10, 25, 50, 80, 100, 125, 160, 200, 250, 320, 400, 500
Maximum strokes (mm)	Ø 32 ÷ 63 = 1000

MATERIALS

End caps	AISI 304 stainless steel
Cylinder barrel	Extruded tube, AISI 304 stainless steel
Barrel-end cover fixing type	Irreversible calking with dual-seal system, mechanical and pneumatic
Piston rod	AISI 316 stainless steel
Rod nut and ring nut	AISI 304 stainless steel
Piston rod bearing	Self lubricating sintered bronze
Piston	Aluminium alloy (supplied with or without magnet)
Seals	Polyurethane - FKM (Viton®)

ORDER KEY

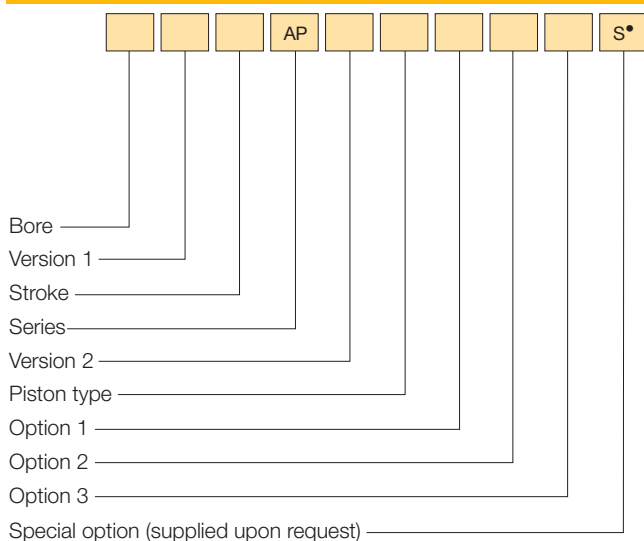

• See chapter 1, page 1.1.

ORDER EXAMPLES

Basic cylinder Ø 32, 50 mm stroke, double acting, non-magnetic piston type: **32/50 APDC**

Basic cylinder Ø 40, 50 mm stroke, double acting, non-magnetic piston type, ATEX: **40/50 APDE/EX**

VERSION 1

/ Basic cylinder **R** Through rod

VERSION 2

D Double acting

PISTON TYPE

C Non-magnetic **E** Magnetic*

OPTION 1

X Cushioned (only the basic version)

OPTION 2

2 Seals for high temperature

OPTION 3

/EX Consistent with the ATEX directive  II 2GD c T5 T100°C -20°C <Ta<80°C

* Available even with "FKM" (Viton®) seals but just for applications where is needed a chemical compatibility; not available for high temperatures.

AP BASIC CYLINDER

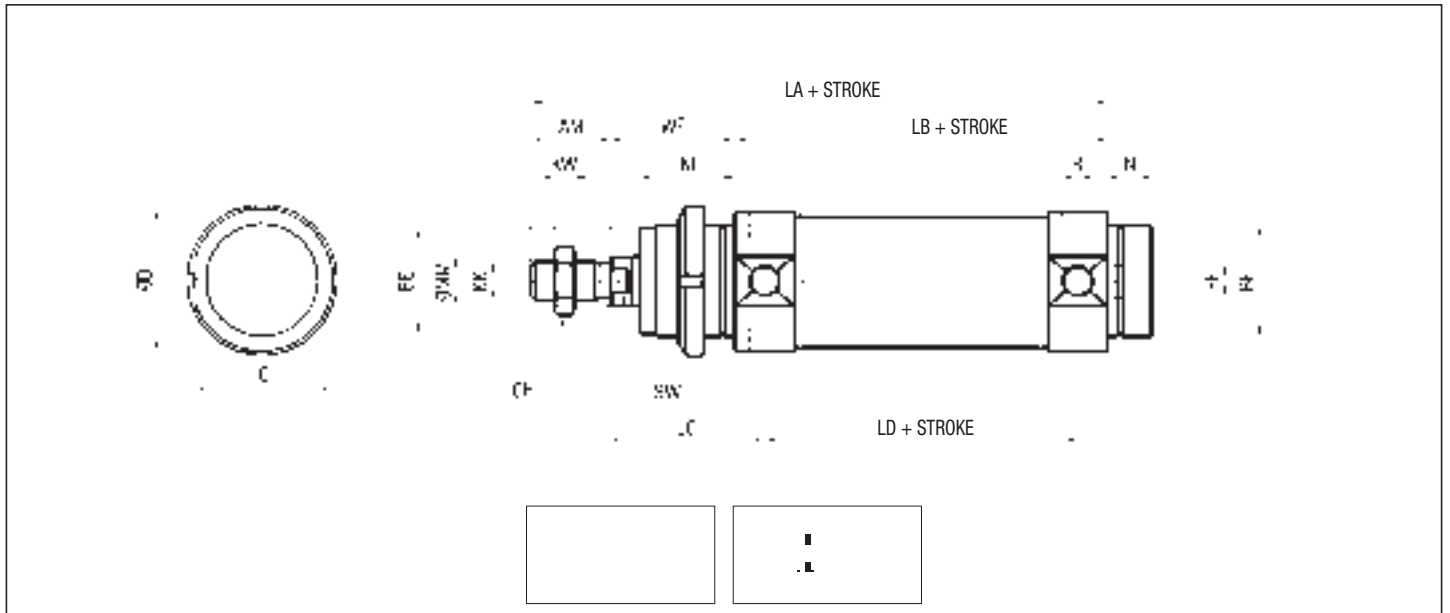

P.S.: End cap ring nuts and rod nuts supplied as standard

DIMENSIONS AND WEIGHTS BASIC CYLINDER

\varnothing	AM	BE	C	CH	D	EE	KK	KW	LA	LB	LC	LD	M	MM	N	R	SW	WF	XC	XD	WEIGHT (g)	INCR. (g) x 10 mm
32	20	M30x1,5	36,5	17	38	G1/8	M10	6	154	96	47	78	30	12	14	M8x1	10	38	134	140	789	16
40	24	M38x1,5	44	19	46	G1/4	M12	7	182	113	57	89	35	16	16	M10x1	12	45	158	163	1410	26
50	32	M45x1,5	55	24	57	G1/4	M16	8	202	120	62	96	38	20	18	M12x1,5	16	50	170	176	2383	34
63	32	M45x1,5	67,5	24	70	G3/8	M16	8	206	124	63	98	38	20	18	M14x1,5	16	50	174	180	3231	50

THROUGH ROD

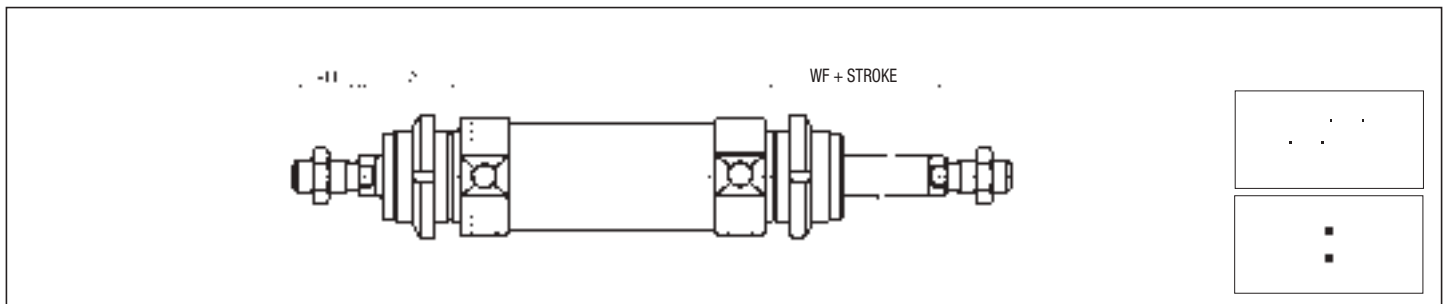

P.S.: End cap ring nuts and rod nuts supplied as standard

1

RING NUT - STAINLESS STEEL - APG Ø

Ø	d	D	S	WEIGHT (g)
32	M30x1,5	42	8	43
40	M38x1,5	50	10	80
50-63	M45x1,5	65	10	122

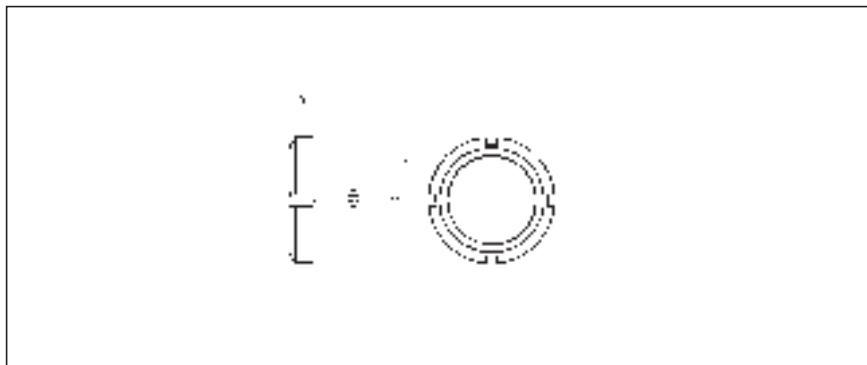

FLANGE/FOOT - STAINLESS STEEL - APFP Ø

Ø	AB	AU	HA	HB	HC	LA	LB	LC
32	7	14	14	49	28	21	124	76
40	9	20	18	58	30	30	153	83
50	9	20	20	70	40	30	160	92
63	9	20	20	80	50	30	164	92

Ø	NH	S	TB	TR	TS	XS	XT	WEIGHT (g)
32	28	4	11	52	66	48	24	98
40	33	5	13	60	80	60	25	183
50	40	6	14	70	90	64	30	276
63	45	6	14	76	96	64	30	395

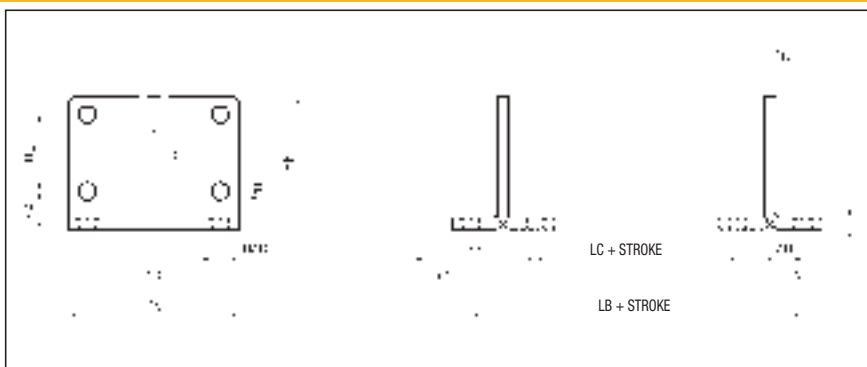

REAR HINGE - STAINLESS STEEL - APSC Ø

Ø	CH	E	G	H	L	LA	LB
32	13	7	20	35	125	20	46,1
40	17	9	27	40	146	28	56,1
50	19	9	30	45	158	36	69,1
63	19	9	34	50	161	42	82,1

Ø	LC	NA	NB	R	S	WEIGHT (g)
32	58	24	40	12	4	150
40	70	30	50	13	5	259
50	86	34	54	14	6	403
63	100	35	65	16	6	520

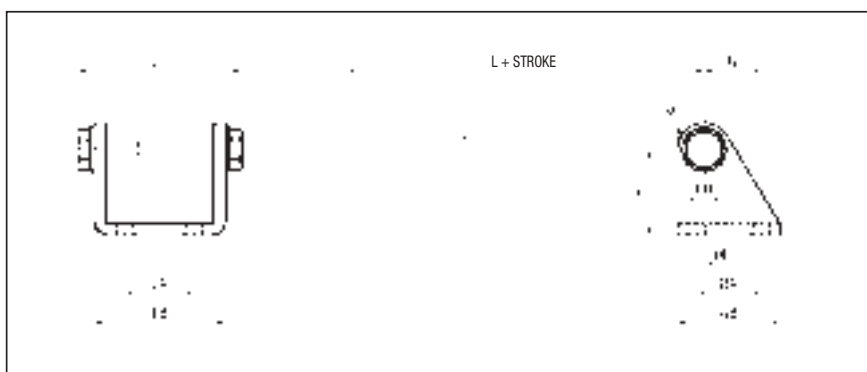

PIVOT (pair) - STAINLESS STEEL - APT Ø

Ø	D	H	LA	LB	CH	WEIGHT (g)
32	10	51	47	125	5	10
40	12	61	57	146	6	20
50	14	75	62	158	6	40
63	16	92	63	161	8	65

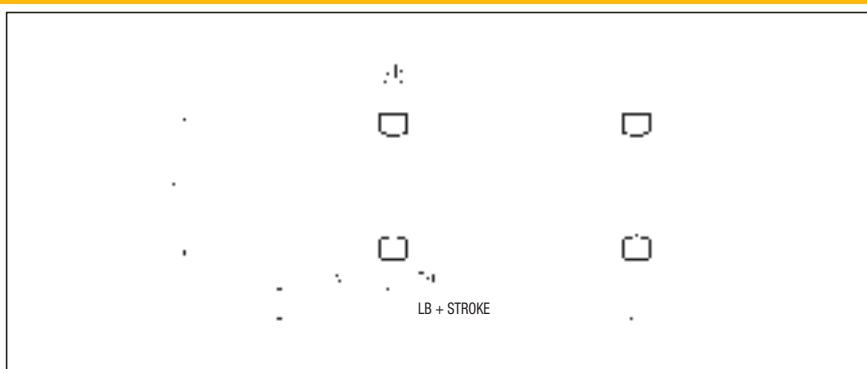

“Clean profile” cylinders to ISO 15552 standard Ø 32 ÷ 100

series X

1



DESCRIPTION

Cylinders series “X”, and their fixing accessories, comply with ISO 15552 standard, being in this way completely interchangeable with the former cylinders to ISO 6431/VDMA 24562 standard. They are available in the bores from Ø 32 to Ø 100 with techno-polymer piston as standard. The cylinder barrel, made in extruded aluminium alloy, has some “T”-slots on three sides where it’s possible to mount directly the magnetic sensors series “FM100”. Upon request, cylinders series “X” comply with ATEX directive, 2GD category. Thanks to proper cover strips that give the cylinders a really clean profile, the cylinders result suitable also for difficult environments like the food one. A further feature is the possibility to assemble some series of valves directly on the cylinder barrel thanks to the brackets type “X/P/M” (see page 1.24).

TECHNICAL DATA

Operating pressure	1 ÷ 10 bar
Working temperature	0 ÷ +80 °C (-35 °C with dry air) 0 ÷ +150 °C with seals for high temperature (-10 °C with dry air)
Fluid	Compressed air, filtered, continuous lubricated, unlubricated or dry lubricated
Versions	Double acting, single acting front spring, single acting rear spring, through rod, double push tandem, double stroke tandem, opposed tandem
Bore	Ø 32, 40, 50, 63, 80, 100
Port size	Ø 32 = G 1/8 Ø 40 - 50 = G 1/4 Ø 63 - 80 = G 3/8 Ø 100 = G 1/2
Standard strokes (mm)*	25, 50, 75, 80, 100, 125, 150, 160, 200, 250, 300, 320, 350, 400, 500, 550, 600, 650, 700, 800, 900, 1000
Decelerators lenght	Ø 32 40 50 63 80 100 mm 24 29 29 35 35 40
Maximum stroke (mm)	Ø 32 ÷ 100 = 3000; versione T, P, V = 1000
Max. stroke single acting (mm)	Ø 32 ÷ 63 = 50, Ø 80 - 100 = 100
Spring theoretical tractive force	See technical data on page 0.13

*Cylinders, with strokes shorter than the decelerators lengths, are NOT cushioned as standard.

MATERIALS

End caps	Painted die-cast aluminium alloy
Cylinder barrel	Extruded profile, 20 µm anodized aluminium alloy
Screws	Steel (self-forming)
Piston rod	C45 chromium-plated steel AISI 303 rolled stainless steel
Rod nut	Steel Stainless steel
Piston rod bearing	Bronze-iron 20%, sintered, self-lubricating
Piston	Techno-polymer (with or without magnet) Aluminium alloy (with or without magnet): for high temperatures, for applications without the effective use of the cushioning and for strokes over 1000 mm.
Seals	Polyurethane FKM (Viton®)
Cover strips	Polyvinylchloride
Spring	Spring steel

ORDER KEY

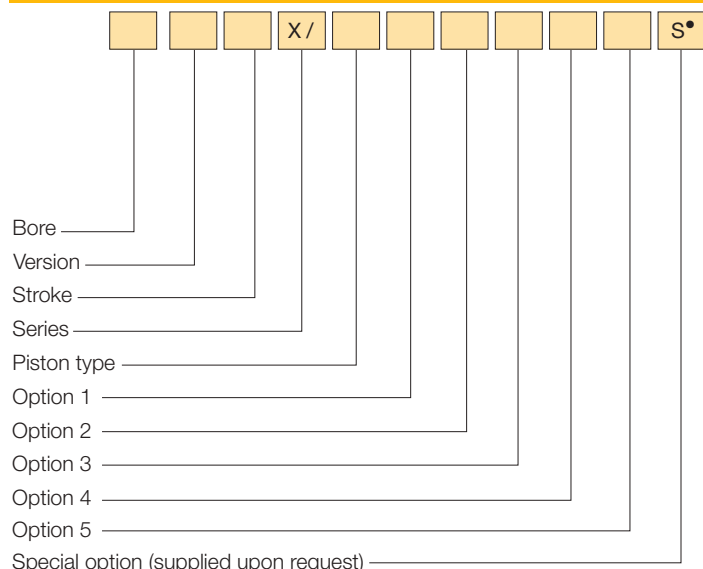

• See chapter 1, page 1.1.

ORDER EXAMPLES

Cylinder Ø 50, double acting, 100 mm stroke, non-magnetic piston type, fit for piston rod locking unit: **50/100 X/NZ**

Cylinder Ø 63, through rod, 150 mm stroke, magnetic piston type, stainless steel piston rod with cover strips: **63R150 X/M14**

Cylinder Ø 80, double stroke tandem, 50 mm stroke 1 + 100 mm stroke 2, magnetic piston type: **80P50+100 X/M**

VERSION

/ Double acting	T Double push tandem*
S Single acting front spring	P Double stroke tandem
Y Single acting rear spring	V Opposed tandem
R Through rod	

PISTON TYPE

N Non-magnetic	M Magnetic**
----------------	--------------

OPTION 1

Z Fit for piston rod locking unit***

OPTION 2

1 Stainless steel piston rod and rod nut	3 Stainless steel piston rod and rod nut and seals for high temperatures*
2 Seals for high temperatures*	

OPTION 3

4 Cover strips for magnetic sensors slots***

OPTION 4

5 Aluminium alloy piston

OPTION 5

/EX Consistent with the ATEX directive II 2GD c T5 T100°C -35°C ≤ Ta ≤ 80°C

* Supplied only with aluminium alloy piston.

** Available even with “FKM” (Viton®) seals but just for applications where is needed a chemical compatibility; not available for high temperatures and ATEX.

*** Don't use it for high temperature application and ATEX.

SPARE PARTS

SEALS KIT

Polyurethane	Ø/SG/X
Through rod polyurethane	Ø/SG/R/X
For high temperatures	Ø/SG/X2
Through rod for high temperatures	Ø/SG/R/X2

1

X BASIC CYLINDER

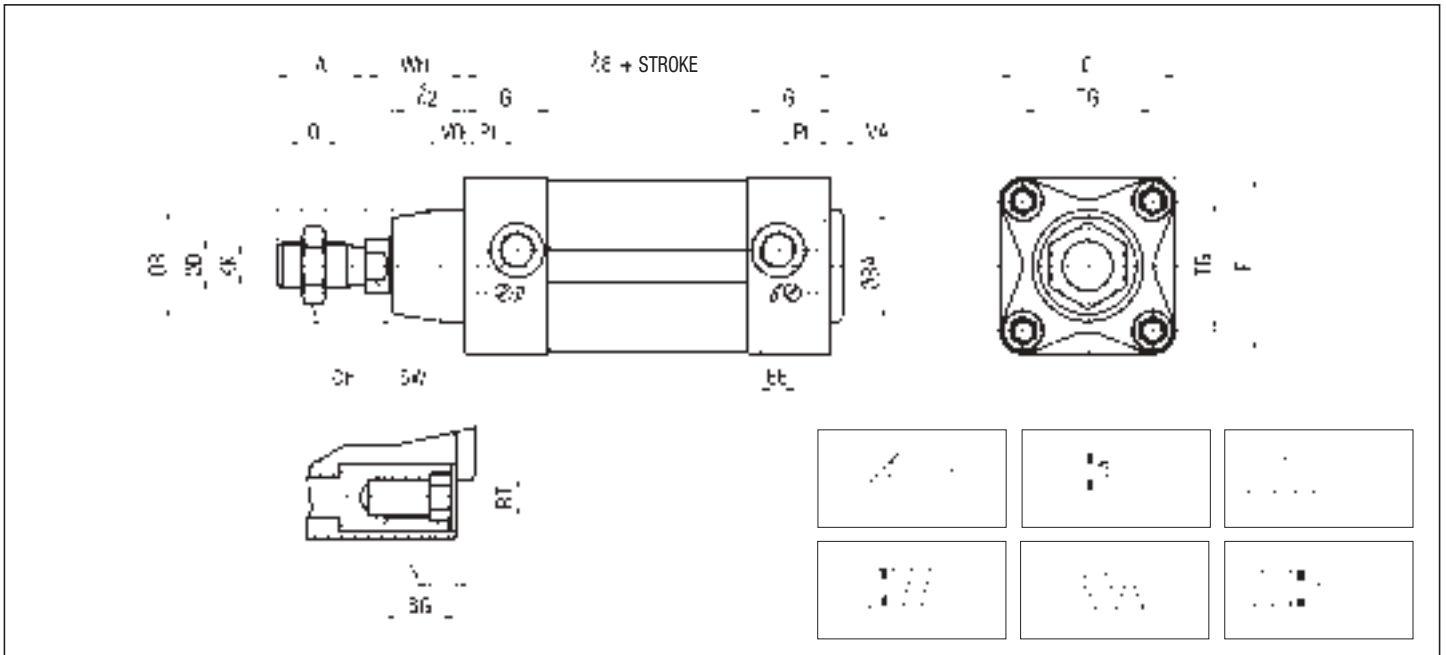

P.S.: Rod nut supplied as standard

DIMENSIONS AND WEIGHTS BASIC CYLINDER

Ø	A*	BA* B*	BG*	CH	D	E*	EE*	G	KK*	l	l2*	l8*	N	O	PL*	R	RT*	SW*	TG*	VA* VD*	WB	WH*	WEIGHT (g)	INCR. (g) every 10 mm
32	22	30	16	17	12	47	G1/8	27	M10x1,25	175	20	94	5,5	6	18	9	M6	10	32,5	3	86	26	555	31
40	24	35	16	19	16	52	G1/4	31	M12x1,25	201	22	105	5,5	7	20,5	9	M6	13	38	3	100	30	809	41
50	32	40	16	24	20	63	G1/4	30	M16x1,5	191	26	106	5,5	8	19	9	M8	17	46,5	3	127	37	1178	59
63	32	45	16	24	20	75	G3/8	35,5	M16x1,5	217	27	121	6,5	8	22	9	M8	17	56,5	4	127	37	1683	60
80	40	45	16	30	25	93	G3/8	36	M20x1,5	240	29	128	6,5	9	23	9	M10	22	72	4	156	46	2683	92
100	40	55	16	30	25	113	G1/2	39	M20x1,5	258	35	138	6,5	9	24	9	M10	22	89	4	161	51	3645	96

* STANDARDIZED DIMENSIONS

THROUGH ROD

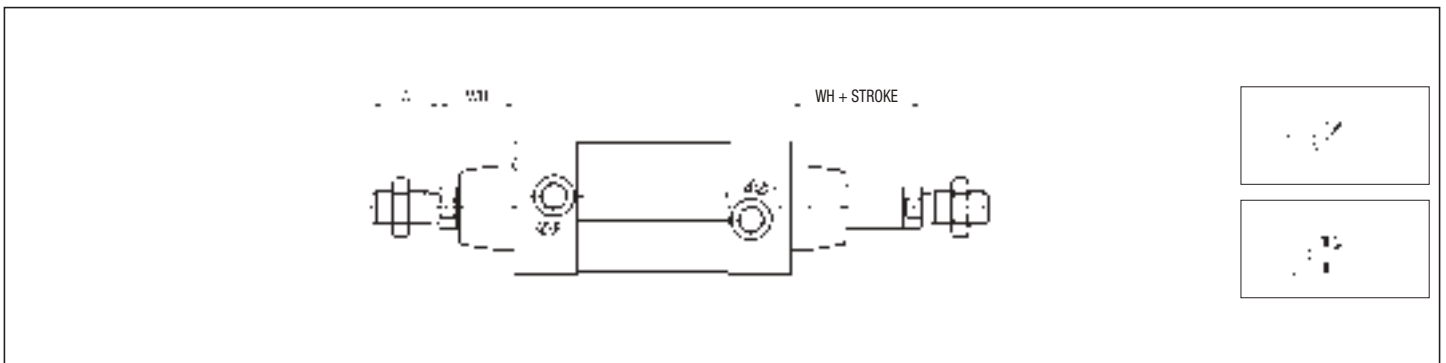

P.S.: Rod nut supplied as standard

DOUBLE PUSH TANDEM

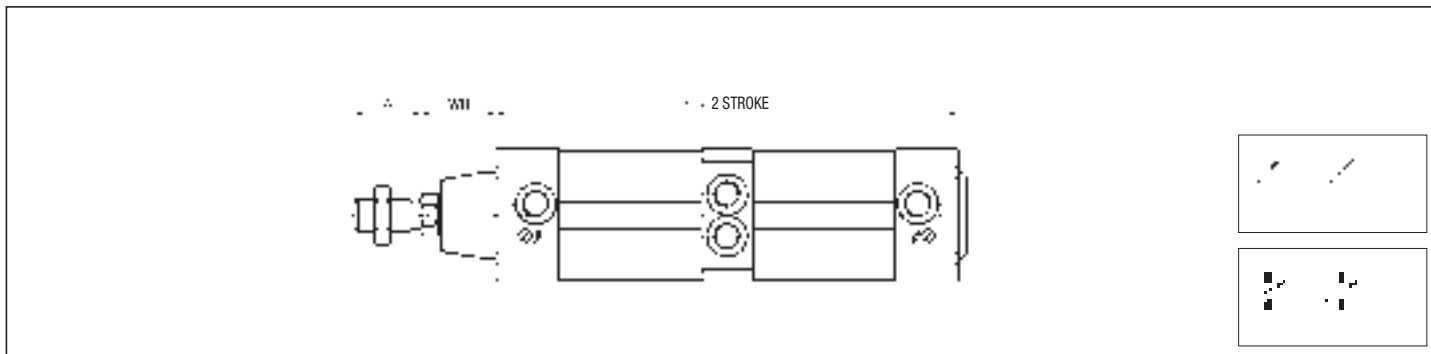

P.S.: Rod nut supplied as standard

DOUBLE STROKE TANDEM

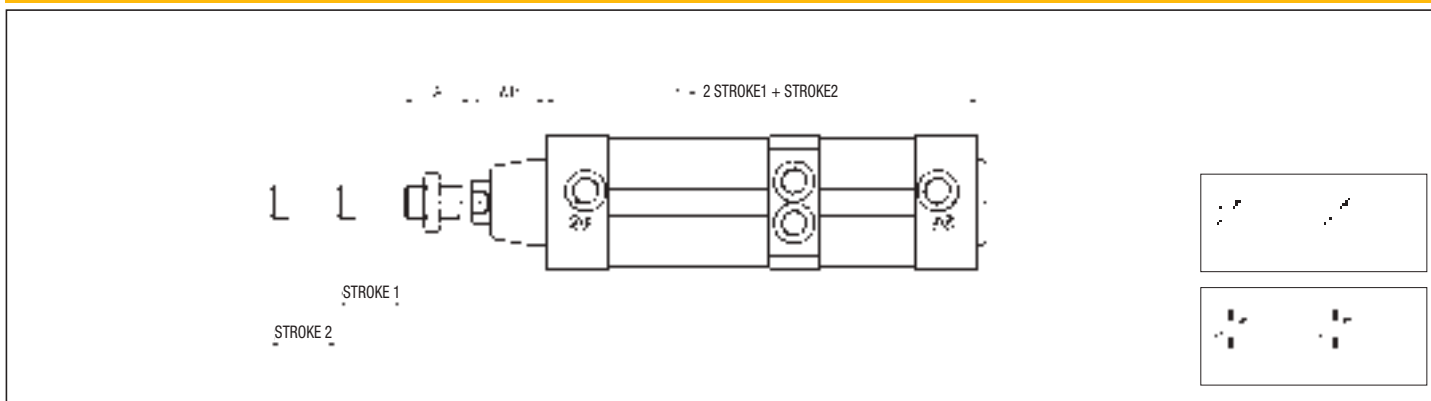

P.S.: Rod nut supplied as standard

OPPOSED TANDEM

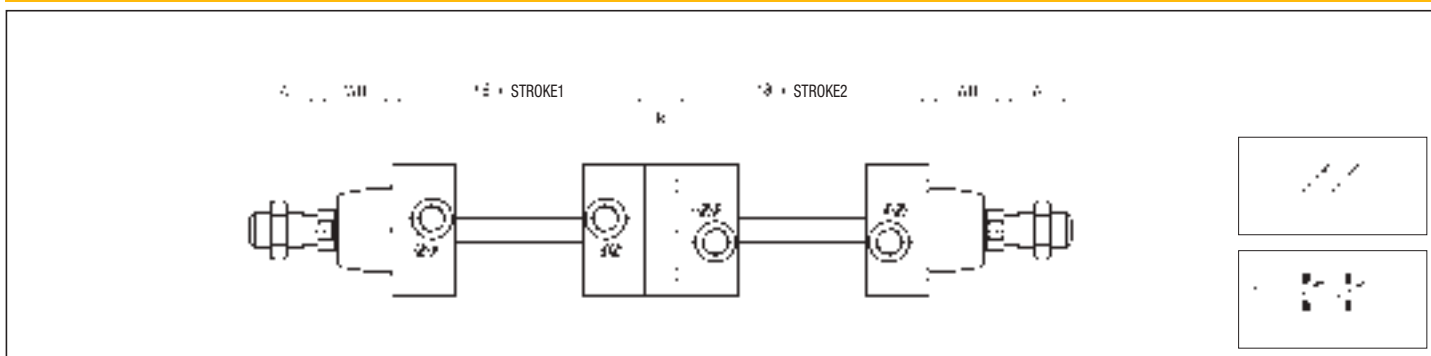

P.S.: Rod nut supplied as standard

FIT FOR PISTON ROD LOCKING UNIT

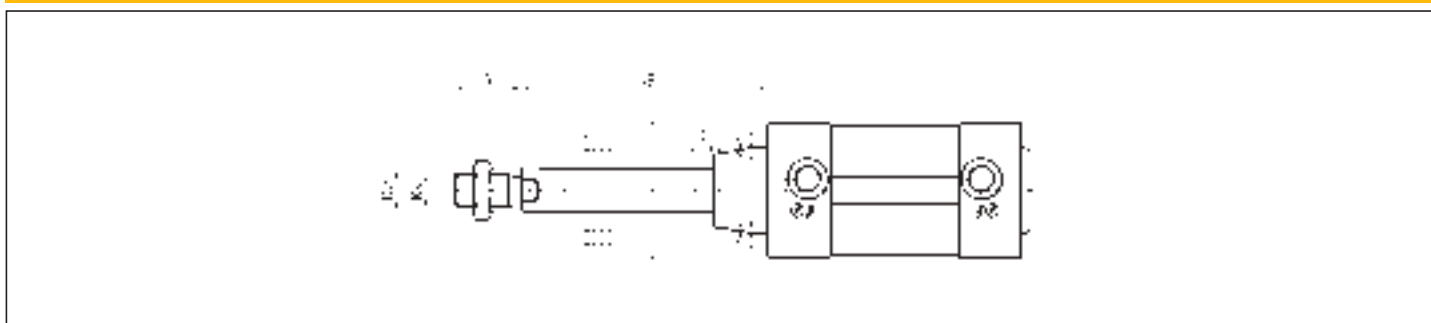

P.S.: Rod nut supplied as standard

1

SMALL SLOT COVER STRIP - X/CP

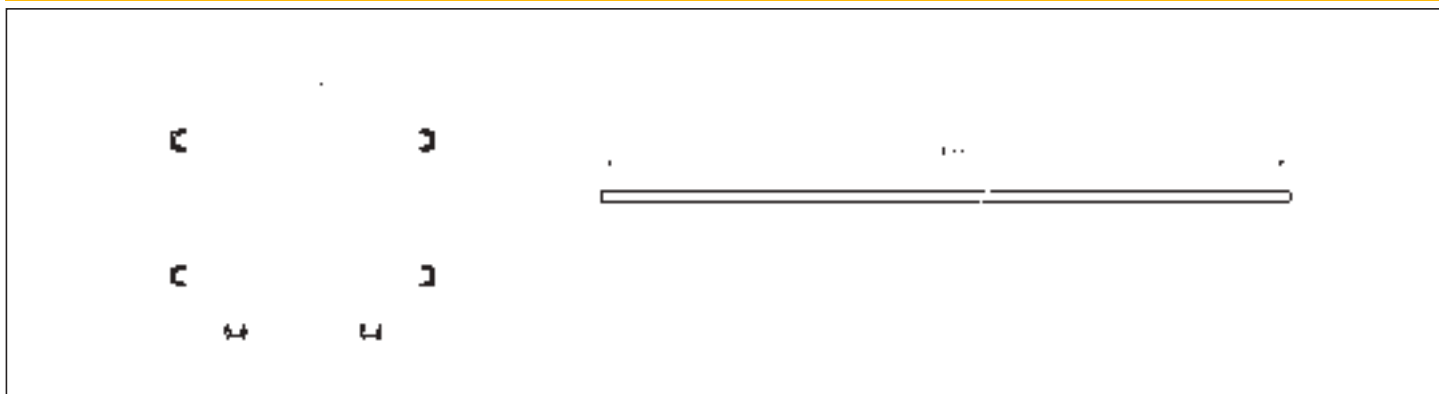

BIG SLOT COVER STRIP - X/CG

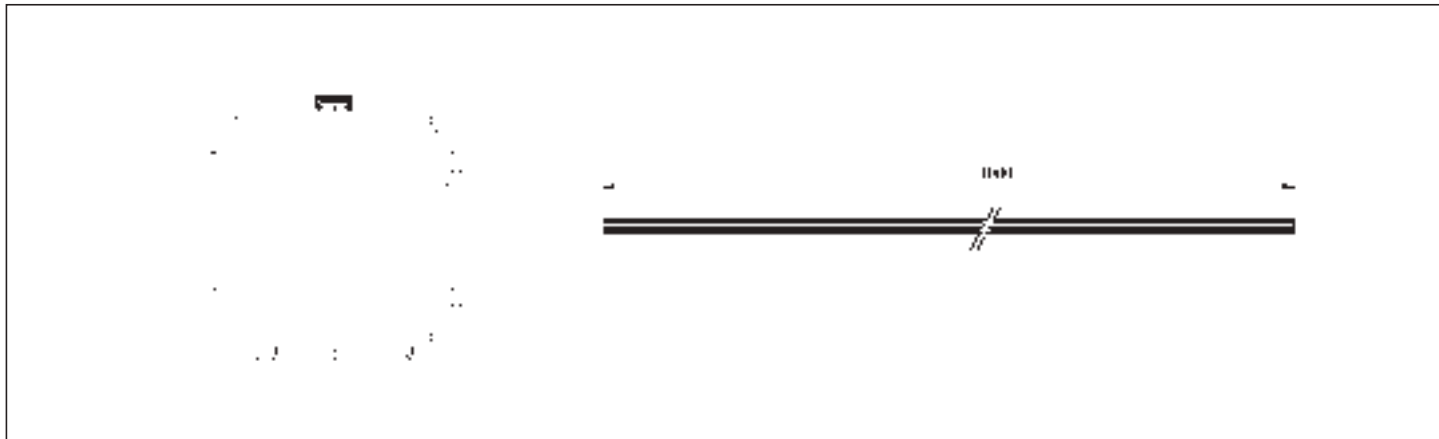

FIXING BRACKETS FOR TEE-SLOTS - X/P/M..

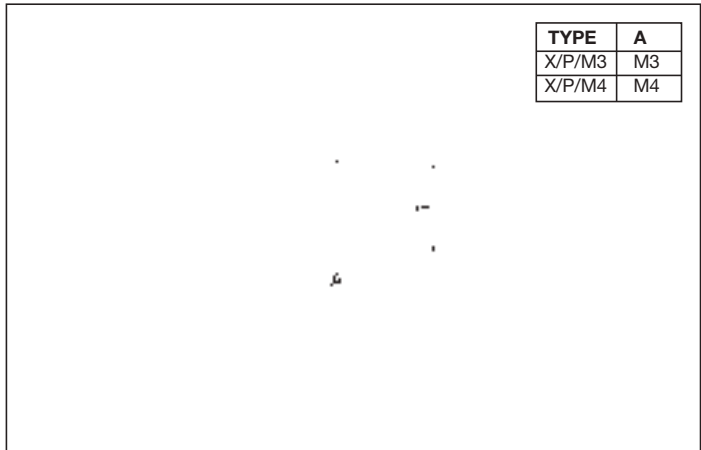

EXAMPLE OF ASSEMBLING OF VALVES MEV-MEK/CYLINDER

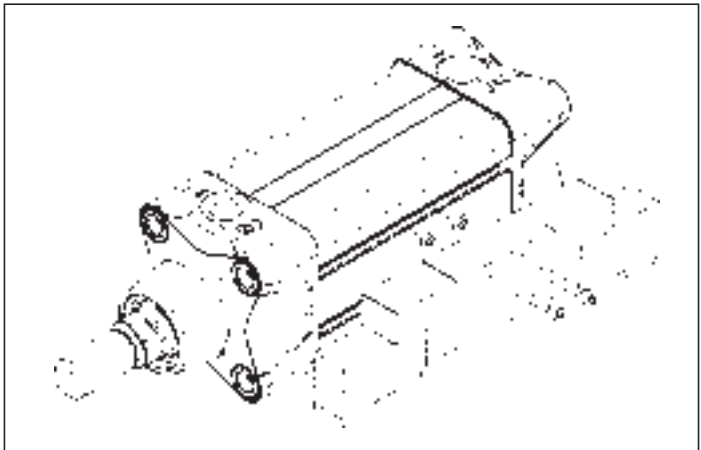

TECHNICAL INFORMATION FIXING BRACKETS

These brackets, with vertical insertion, allow to assembling directly on the cylinder barrel some series of valves and can be used even as reference point for the replacement of magnetic sensors.

“Mickey mouse” profile with TEE-slots cylinders to ISO 15552 standard Ø 32 ÷ 100

series XT

1



DESCRIPTION

Cylinders series “XT”, and their fixing accessories comply with ISO 15552 standard, being in this way completely interchangeable with the former cylinders to ISO 6431/VDMA 24562 standard. They are available in the bores from Ø 32 to Ø 100 with techno-polymer piston as standard and the barrel, a profile in extruded aluminium alloy “mickey mouse” style, has two TEE-slots on one side where it's possible to mount directly the magnetic sensors series “FM100”. Upon request, cylinders series “XT” comply with ATEX directive, 2GD category.

TECHNICAL DATA

Operating pressure	1 ÷ 10 bar
Working temperature	0 ÷ +80° C (-35° C with dry air) 0 ÷ +150° C with seals for high temperatures (-10° C with dry air)
Fluid	Compressed air, filtered, continuous lubricated, unlubricated or dry lubricated
Versions	Double acting, single acting front spring, single acting rear spring, through rod, double push tandem, double stroke tandem, opposed tandem
Bore	Ø 32, 40, 50, 63, 80, 100
Port size	Ø 32 = G 1/8 Ø 40 - 50 = G 1/4 Ø 63 - 80 = G 3/8 Ø 100 = G 1/2
Standard strokes (mm)*	25, 50, 75, 80, 100, 125, 150, 160, 200, 250, 300, 320, 350, 400, 500, 550, 600, 650, 700, 800, 900, 1000
Decelerators lenght	Ø 32 40 50 63 80 100 mm 24 29 29 35 35 40
Max strokes (mm)	Ø 32 ÷ 100 = 3000; versione T, P, V = 1000
Max strokes single act. (mm)	Ø 32 ÷ 63 = 50, Ø 80 - 100 = 100
Spring theoretical tractive force	See technical data on page 0.13

*Cylinders, with strokes shorter than the decelerators lengths, are NOT cushioned as standard.

MATERIALS

End caps	Painted die-cast aluminium alloy
Cylinder barrel	Extruded profile, 20 µm anodized aluminium alloy
Screws	Steel (self-forming)
Piston rod	C45 chromium-plated steel AISI 303 rolled stainless steel
Rod nut	Steel Stainless steel
Piston rod bearing	Bronze-iron 20%, sintered, self-lubricating
Piston	Techno-polymer (with or without magnet) Aluminium alloy (with or without magnet): for high temperatures, for applications without the effective use of the cushioning and for strokes over 1000 mm.
Seals	Polyurethane FKM (Viton®)
Cover strips	Polyvinylchloride
Springs	Spring steel

ORDER KEY

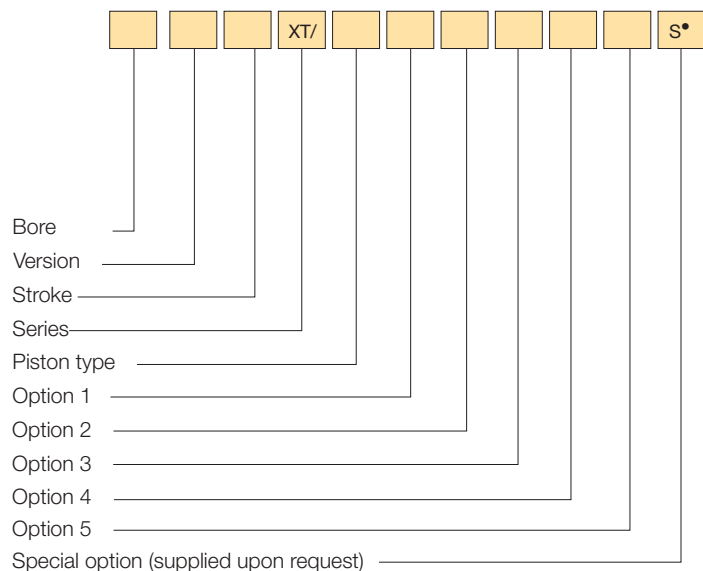

• See chapter 1, page 1.1.

VERSION

/ Double acting	T Double push tandem*
S Single acting front spring	P Double stroke tandem
Y Single acting rear spring	V Opposed tandem
R Through rod	

PISTON TYPE

N Non-magnetic	M Magnetic**
----------------	--------------

OPTION 1

Z Fit for piston rod locking unit***

OPTION 2

1 Stainless steel piston rod and rod nut	3 Stainless steel piston rod, rod nut and seals for high temperatures*
2 Seals for high temperatures*	

OPTION 3

4 Cover strips for magnetic sensors slots***

OPTION 4

5 Aluminium alloy piston

OPTION 5

/EX Consistent with the ATEX directive II 2GD c T5 T100°C -35°C ≤ T_{as} ≤ 80°C

* Supplied only with aluminium alloy piston.

** Available even with “FKM” (Viton®) seals but just for applications where is needed a chemical compatibility; not available for high temperatures and ATEX.

*** Don't use it for high temperature application and ATEX.

SPARE PARTS

SEALS KIT

Polyurethane	Ø/SG/X
Through rod polyurethane	Ø/SG/R/X
For high temperatures	Ø/SG/X2
Through rod for high temperatures	Ø/SG/R/X2

ORDER EXAMPLES

Cylinder Ø 50, double acting, 100 mm stroke, non-magnetic piston type, fit for piston rod locking unit: **50/100 XT/NZ**

Cylinder Ø 63, through rod, 150 mm stroke, magnetic piston type, stainless steel piston rod with cover strips: **63R150 XT/M14**

1

XT BASIC CYLINDER

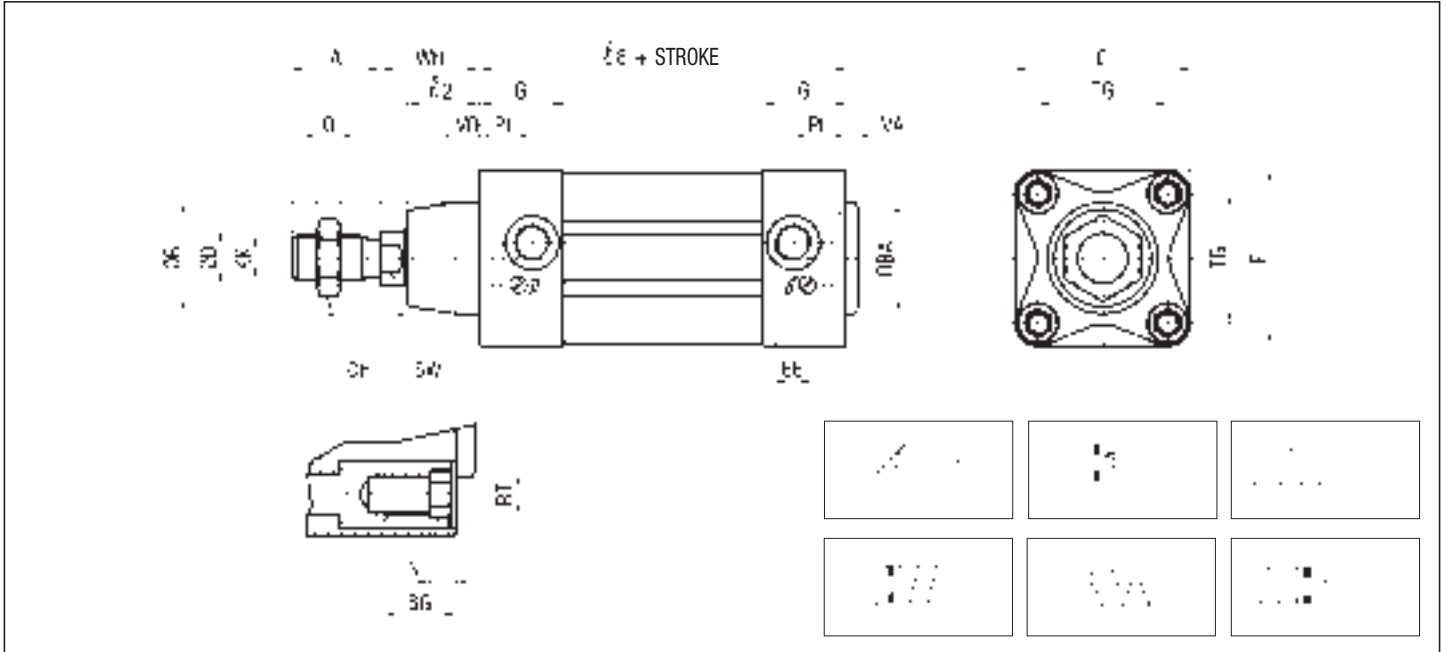

P.S.: Rod nut supplied as standard

DIMENSIONS AND WEIGHTS BASIC CYLINDER

\varnothing	A*	BA* B*	BG*	CH	D	E*	EE*	G	KK*	l	l2*	l8*	N	O	PL*	R	RT*	SW*	TG*	VA* VD*	VB	WH*	WEIGHT (g)	INCR. (g) every 10 mm
32	22	30	16	17	12	47	G1/8	27	M10x1,25	175	20	94	5,5	6	18	9	M6	10	32,5	3	86	26	533	23
40	24	35	16	19	16	52	G1/4	31	M12x1,25	201	22	105	5,5	7	20,5	9	M6	13	38	3	100	30	777	32
50	32	40	16	24	20	63	G1/4	30	M16x1,5	191	26	106	5,5	8	19	9	M8	17	46,5	3	127	37	1148	45
63	32	45	16	24	20	75	G3/8	35,5	M16x1,5	217	27	121	6,5	8	22	9	M8	17	56,5	4	127	37	1621	48
80	40	45	16	30	25	93	G3/8	36	M20x1,5	240	29	128	6,5	9	23	9	M10	22	72	4	156	46	2569	67
100	40	55	16	30	25	113	G1/2	39	M20x1,5	258	35	138	6,5	9	24	9	M10	22	89	4	161	51	3550	77

* STANDARDIZED DIMENSIONS

THROUGH ROD

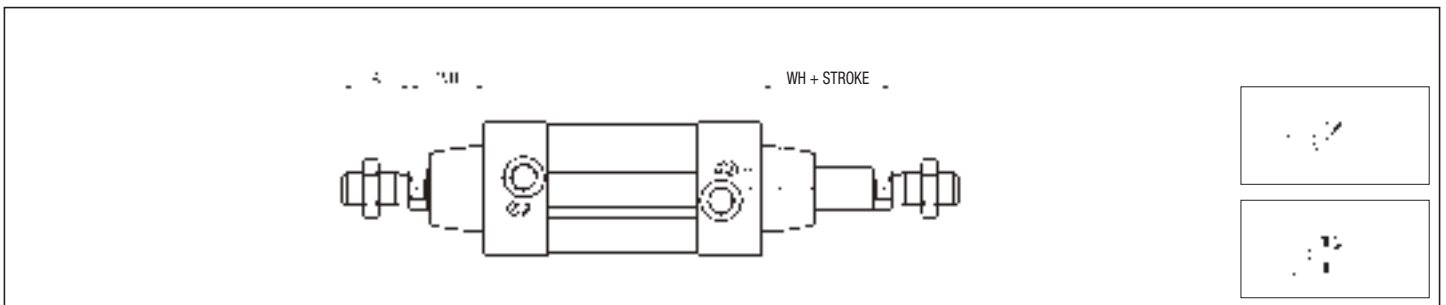

P.S.: Rod nut supplied as standard

DOUBLE PUSH TANDEM

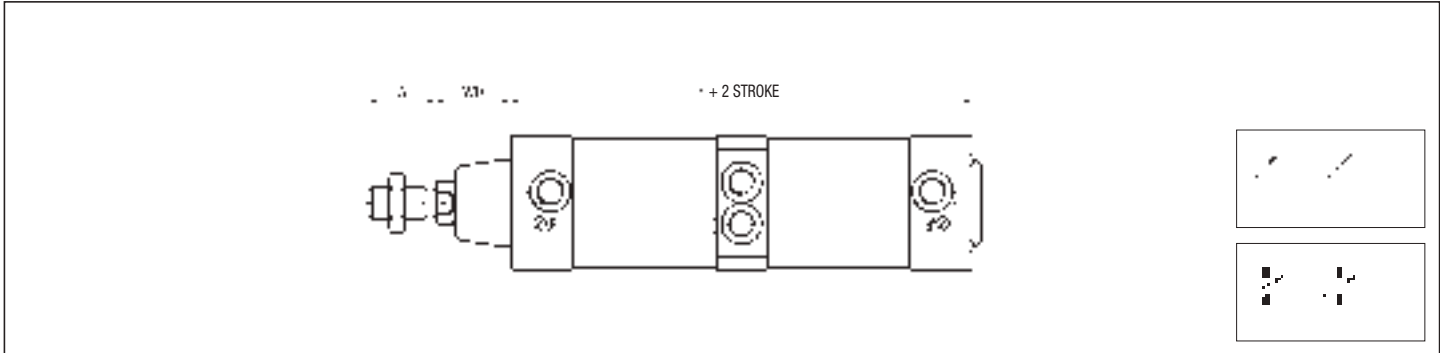

P.S.: Rod nut supplied as standard

DOUBLE STROKE TANDEM

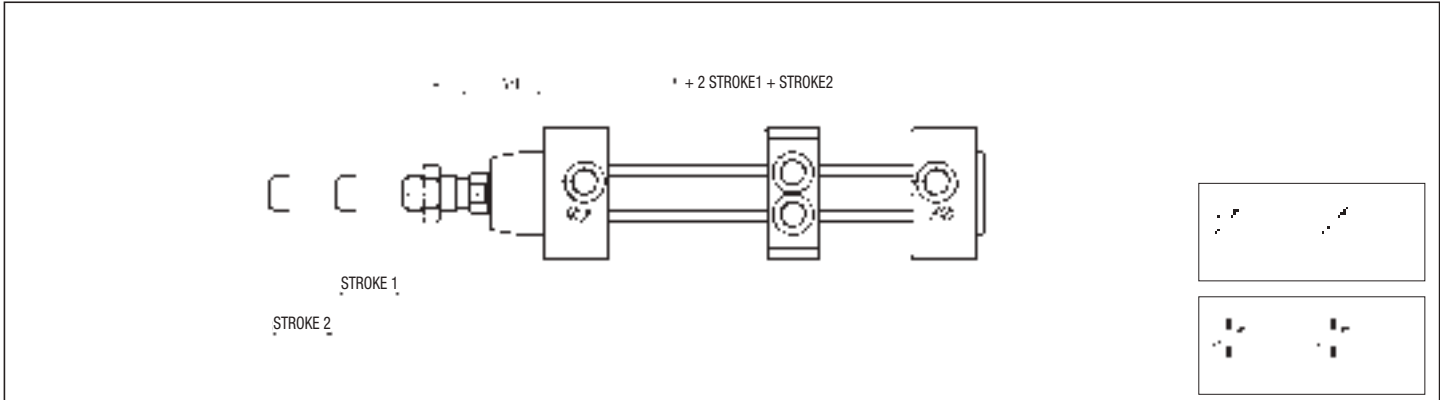

P.S.: Rod nut supplied as standard

OPPOSED TANDEM

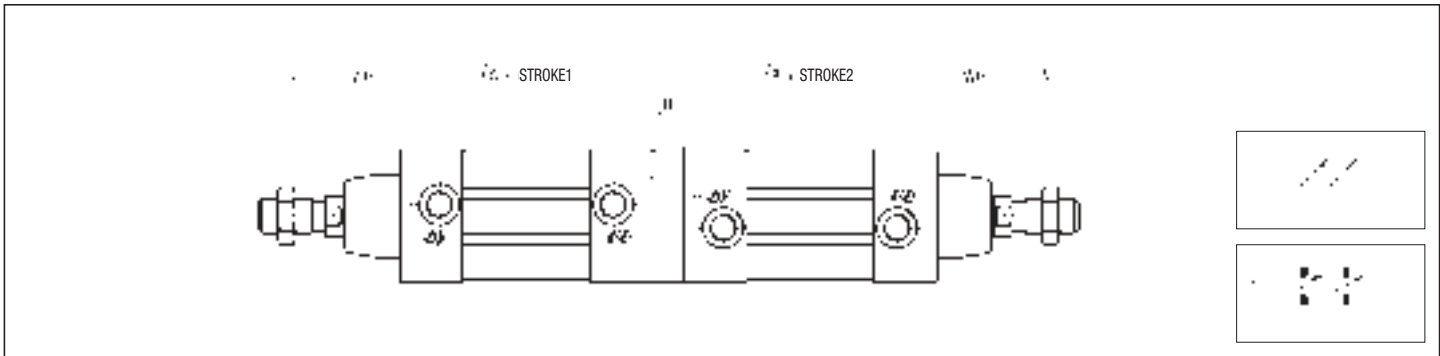

P.S.: Rod nut supplied as standard

FIT FOR PISTON ROD LOCKING UNIT

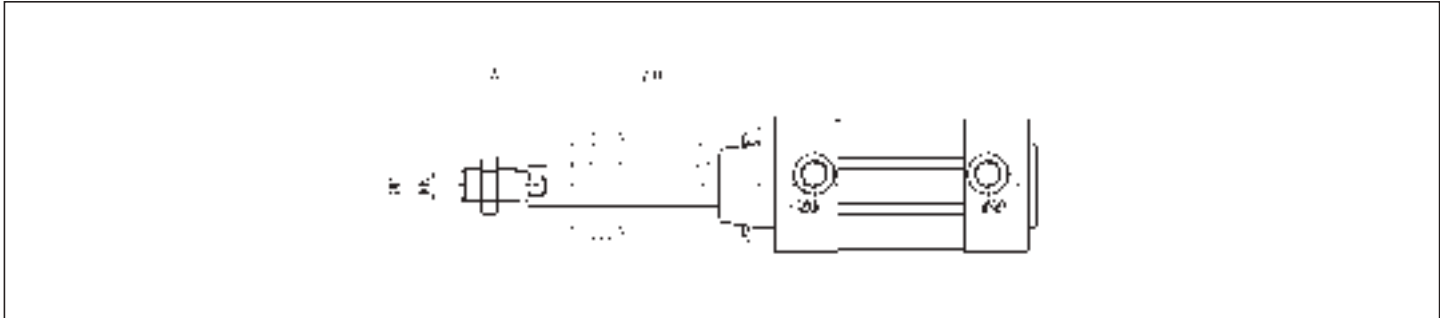

P.S.: Rod nut supplied as standard

Tie rods cylinders to ISO 15552 standard Ø 125 ÷ 320

series XL

1

DESCRIPTION

Cylinders series "XL", and their fixing accessories, comply with ISO 15552 standard, being in this way completely interchangeable with the former cylinders to ISO 6431 /VDMA 24562 standard. These cylinders are supplied cushioned as standard and, in the version with magnetic piston type, can be supplied with magnetic sensors. Upon request, cylinders series "XL" comply with ATEX directive, 2GD category.



TECHNICAL DATA

Operating pressure	1÷10 bar
Working temperature	0 ÷ +80 °C (-30 °C with dry air) 0 ÷ +150 °C with seals for high temperatures (-10 °C with dry air)
Fluid	Compressed air, filtered, continuous lubricated, unlubricated or dry lubricated
Versions	Double acting, single acting front spring, single acting rear spring, through rod, double push tandem, double stroke tandem, opposed tandem
Bore	Ø 125, 160, 200, 250, 320
Port size	Ø 125 = G 1/2 Ø 160-200 = G 3/4 Ø 250-320 = G 1
Standard strokes (mm)*	25, 50, 75, 80, 100, 125, 150, 160, 175, 200, 250, 300, 320, 350, 400, 450, 500, 550, 600, 650, 700, 800, 900, 1000
Decelerators length	Ø 125 160 200 250 320 mm 37 40 40 75 80
Max strokes (mm)	Ø 125 ÷ 320 = 3000; version T, P, V = 1000

*Cylinders, with strokes shorter than the decelerators lengths, are NOT cushioned as standard (only for Ø125÷200).

MATERIALS

End caps	Painted die-cast aluminium alloy
Cylinder barrel	Extruded profile, 20 µm anodized aluminium alloy
Tie rods, tie and rod nuts	Steel Stainless steel (supplied upon request for tie rods and tie nuts)
Rod nut	C45 chromium-plated steel AISI 304 rolled stainless steel
Piston rod bearing	Bronze-iron 20%, sintered, self-lubricating
Decelerators ogives	Aluminium alloy
Piston	Die-cast aluminium alloy (magnetic and non-magnetic)
Seals	Polyurethane and NBR rubber FKM (Viton®) only for Ø 125 ÷ 200

ORDER KEY

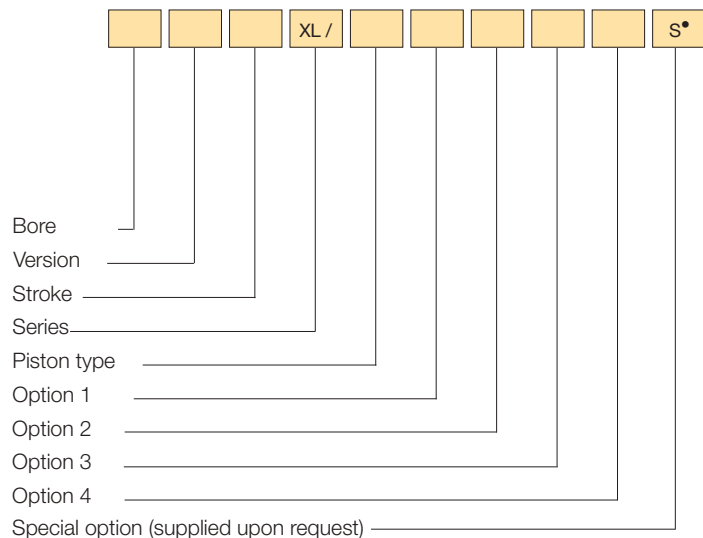

• See chapter 1, page 1.1.

VERSION

/ Double acting	S Single acting front spring*
R Through rod	Y Single acting rear spring*
T Double push tandem*	P Double stroke tandem*
V Opposed tandem*	

PISTON TYPE

N Non-magnetic	M Magnetic**
----------------	--------------

OPTION 1

Z Fit for piston rod locking unit (only for Ø 125)***

OPTION 2

1 Stainless steel piston rod and rod nut	3 Stainless steel piston rod, rod nut and seals for high temperatures
2 Seals for high temperatures	

OPTION 3

5 Extruded profile (only for Ø 125)

OPTION 4

/EX Consistent with the ATEX directive II 2GD c T5 T1 00°C -20°C<Ta<80°C

* Supplied only for Ø 125 ÷ 200.

** Available even with "FKM" (Viton®)seals but just for applications where is needed a chemical compatibility; not available for high temperatures.

*** Don't use it for high temperature application.

ORDER EXAMPLES

Cylinder Ø 125, double acting, 100 mm stroke, non-magnetic piston type, ATEX: **125/100 XL/N/EX**

Cylinder Ø 320, through rod, 150 mm stroke, magnetic piston type, stainless steel piston rod: **320R150 XL/M1**

SPARE PARTS

SEALS KIT	
Polyurethane	Ø/SG/XL
Through rod polyurethane	Ø/SG/R/XL
For high temperatures	Ø/SG/XL2
Through rod for high temperatures	Ø/SG/R/XL2

1

XL BASIC CYLINDER

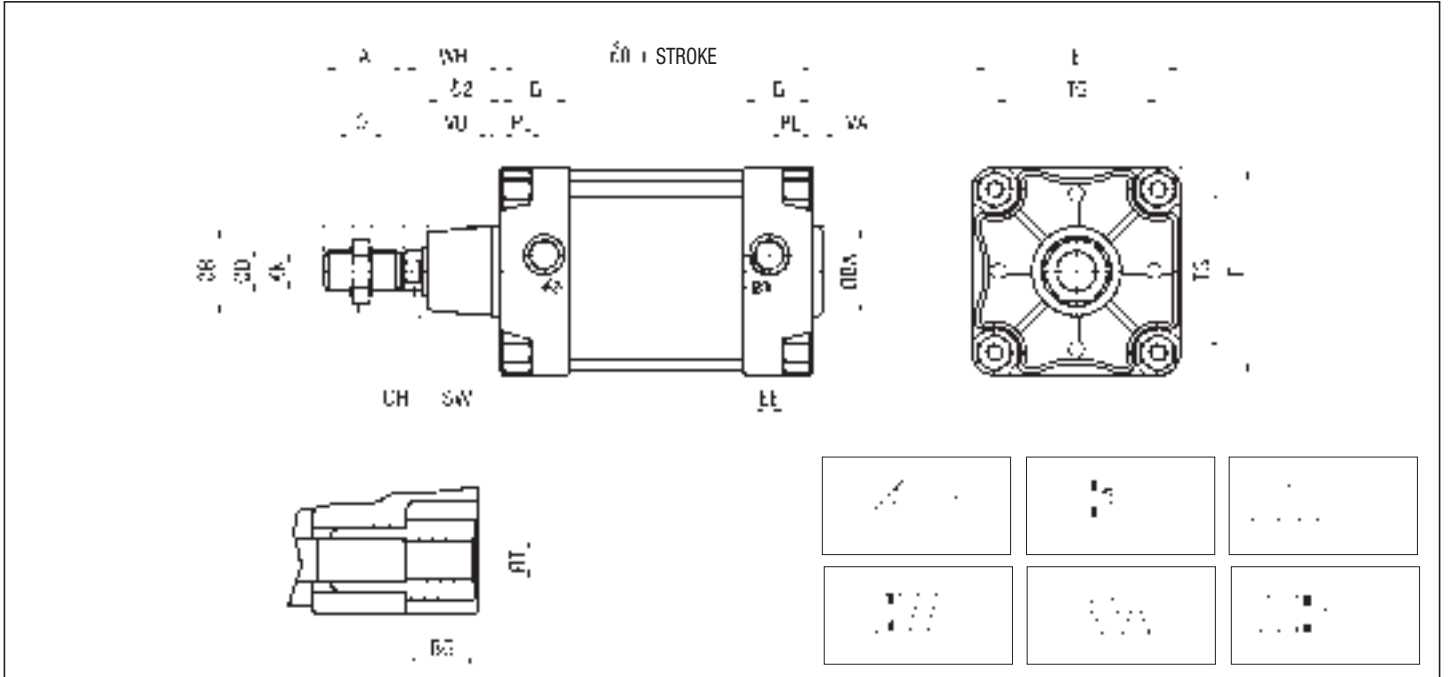

P.S.: Rod nut supplied as standard

DIMENSIONS AND WEIGHTS BASIC CYLINDER

Ø	A*	BA* B*	BG*	CH	D	E*	EE*	G	KK*	ℓ	ℓ2*	ℓ8*	O	PL*	RT*	SW*	TG*	VA*	VD*	WB	WH*	WEIGHT (g)	INCR. (g) every 10 mm
125	54	60	20	41	32	140	G1/2	46	M27x2	268	50	160	12	29	M12	27	110	6	7	205	65	6475	126
160	72	65	24	55	40	180	G3/4	50	M36x2	310	60	180	15	30	M16	36	140	6	6	-	80	10850	210
200	72	75	24	55	40	220	G3/4	48	M36x2	310	60	180	15	24	M16	36	175	6	6	-	95	15075	290
250	84	90	25	65	50	268	G1	54	M42x2	-	67	200	16	31	M20	46	220	10	20	-	105	28500	380
320	96	110	28	75	63	340	G1	66	M48x2	-	82	220	18	31	M24	55	270	10	20	-	120	48400	620

* STANDARDIZED DIMENSIONS

THROUGH ROD

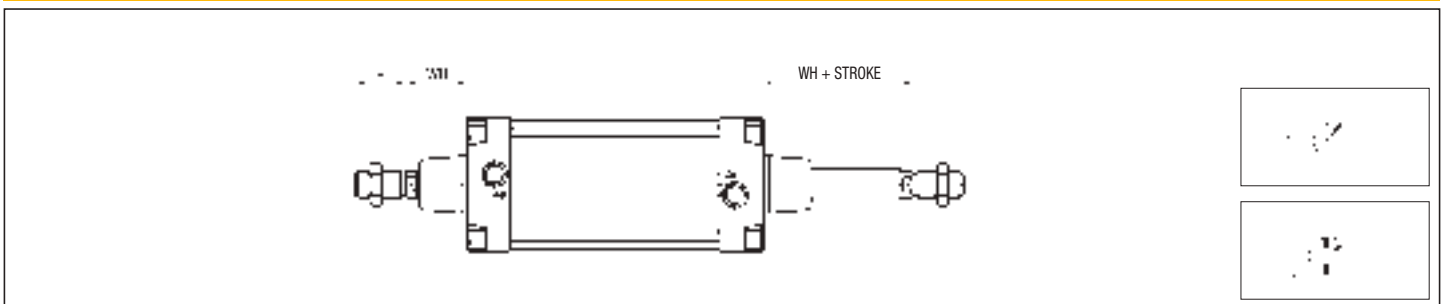

P.S.: Rod nut supplied as standard

DOUBLE PUSH TANDEM

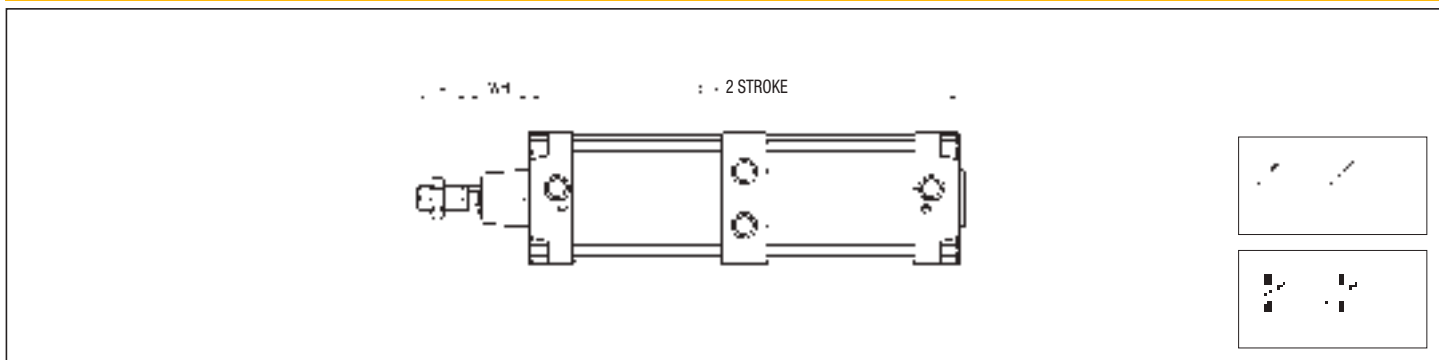

P.S.: Rod nut supplied as standard

DOUBLE STROKE TANDEM

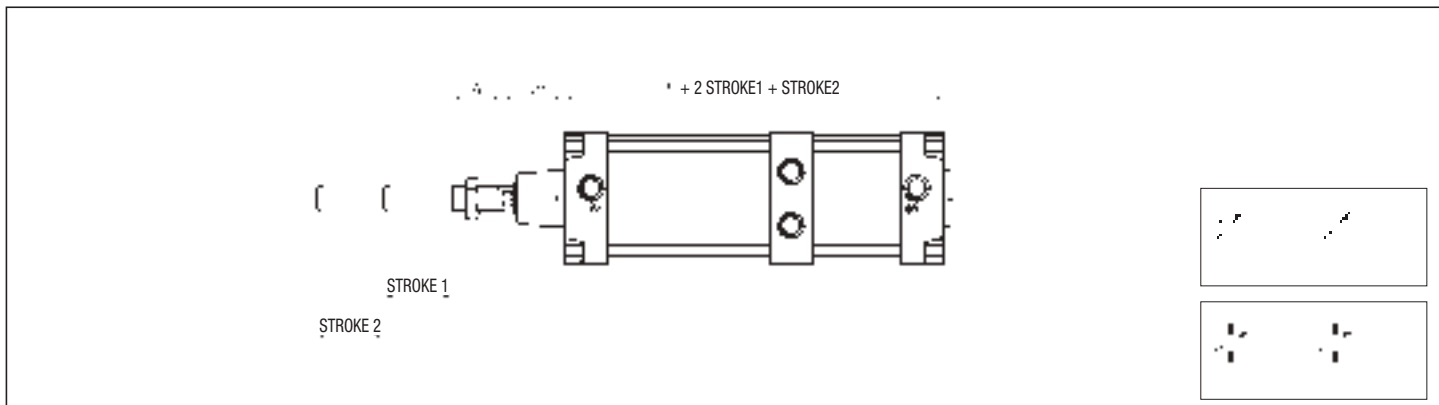

P.S.: Rod nut supplied as standard

OPPOSED TANDEM

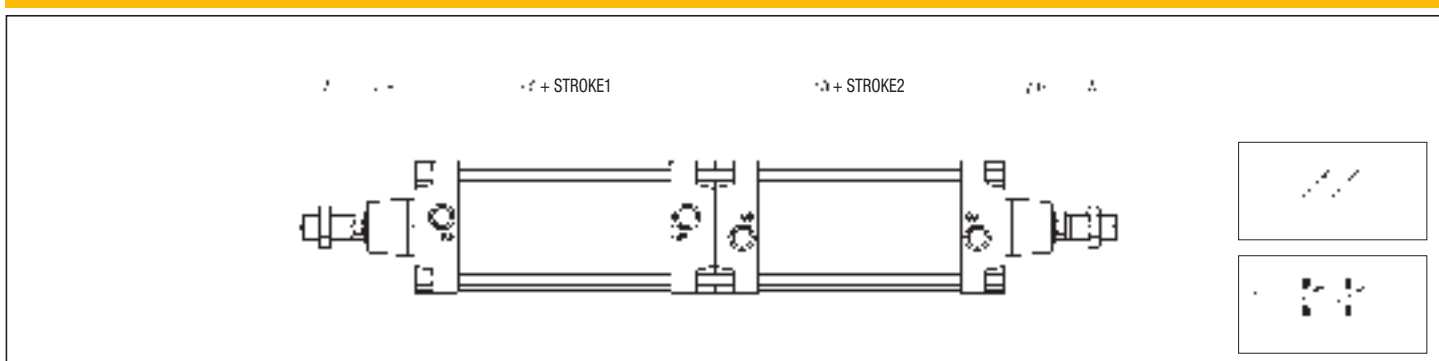

P.S.: Rod nut supplied as standard

FIT FOR PISTON ROD LOCKING UNIT

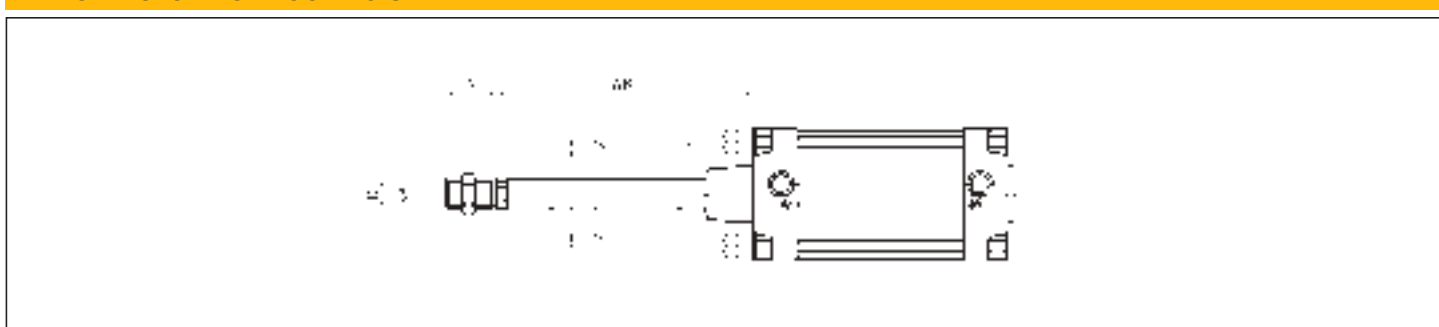

P.S.: Rod nut supplied as standard

LOW FRICTION CYLINDER SEALS

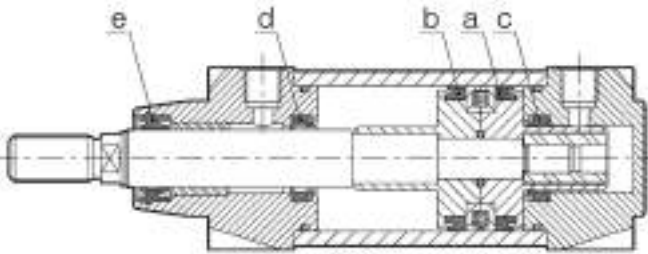

- a) Piston seal for rear chamber
- b) Piston seal for front chamber
- c) Cushioning seal rear chamber
- d) Cushioning seal front chamber
- e) Piston rod seal

APPLICATIONS

DESCRIPTION	OPTION	SEALS
Rear chamber	SA	a
Rear chamber + cushion	SB	a + c
Rear chamber + piston rod seal	SC	a + e
Rear chamber + cushion + piston rod seal	SD	a + c + e
Front chamber + piston rod seal	SE	b + e
Front chamber + cushion	SF	b + d + e
Linear sliding	S7	a + b + c + d + e

DESCRIPTION

Low friction cylinders, of U, P, XT and XL Series (from Ø 125 to Ø 200), are used as “dancers” or “stretchers” cylinders, but indeed they are single acting cylinders without the return spring. As indicated in the previous table, various applications are possible, considering the different seals are present inside the cylinder. Main application is the one indicated by “SA” option, as being “a” the only used seal, it’s the one that offers less friction force.

“SB” application uses the pneumatic cushion in case of emergency, to avoid shocks in case of system damage.

In “SC” and “SD” options, the piston rod seals avoids the entry of impurities into the cylinder.

In “SE” option front chamber is under pressure, indeed in “SF” option front chamber is under pressure, but with the cushion in case of emergency. In “S7” option seals are in NBR. Mounting uses specific grease.

P.S. Contact our commercial office for low friction cylinders of other series.

ATTENTION: for the application, consider the cylinder as a single acting cylinder without spring.

ORDER EXAMPLES

Cylinder Ø 50, double acting, 100 mm stroke, magnetic piston type, rear chamber seals and cushion: **50/100 XT/M SB**

Cylinder Ø 125, double acting, 200 mm stroke, magnetic piston type, front chamber seals and cushion: **125/200 XL/M SF**

Accessories

CPUI - Fixings for cylinders to ISO 15552 standard Ø 32 ÷ 320

FLANGE - STEEL - CPUI/F Ø (supplied with screws)

Ø	D H11	FB H13	E	MF JS14	R JS14	TF JS14	UF
32	30	7	45	10	32	64	80
40	35	9	52	10	36	72	90
50	40	9	65	12	45	90	110
63	45	9	75	12	50	100	120
80	45	12	95	16	63	126	150
100	55	14	115	16	75	150	170
125	60	16	140	20	90	180	205
160	65	18	180	20	115	230	260
200	75	22	220	25	135	270	300
250	90	26	285	25	165	330	400
320	110	33	350	30	200	400	470

Ø	W	ZF	WEIGHT (g)
32	16	130	192
40	20	145	250
50	25	155	480
63	25	170	620
80	30	190	1450
100	35	205	1985
125	45	245	3750
160	60	280	6350
200	70	300	11300
250	80	330	20100
320	90	370	31800

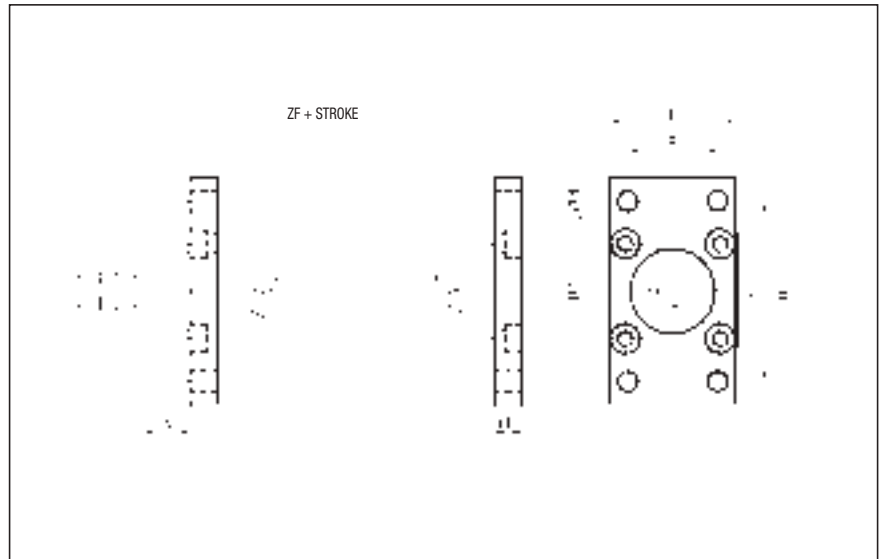

FOOT - STEEL - CPUI/PB Ø (supplied with screws)

Ø	AB H14	AH JS15	AT	AU	E	F	SA
32	7	32	4	24	45	35	142
40	9	36	4	28	52	36	161
50	9	45	5	32	65	47	170
63	9	50	5	32	75	45	185
80	12	63	6	41	95	55	210
100	14	71	6	41	115	57	220
125	16	90	8	45	140	70	250
160	18	115	9	60	180	75	300
200	22	135	12	70	220	100	320
250	26	165	14	75	270	100	400

Ø	TR JS14	XA	WEIGHT (g)
32	32	144	66
40	36	163	78
50	45	175	168
63	50	190	190
80	63	215	382
100	75	230	452
125	90	270	1090
160	115	320	1188
200	135	345	3450
250	165	430	6600

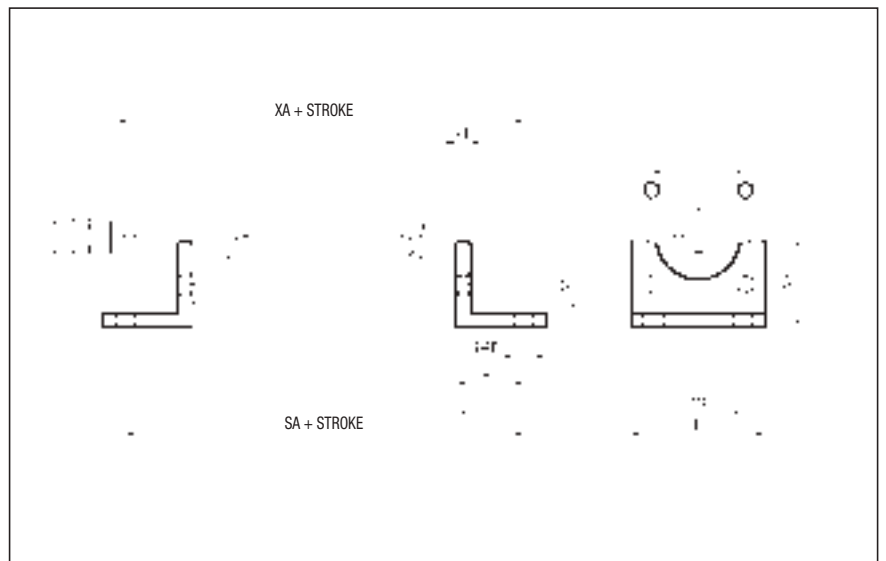

FRONT FEMALE HINGE - NOT CONFORM TO ISO STANDARD - ALUMINIUM - CPUI/CFA Ø (supplied with screws)

Ø	CB	CD H9	E	FL	L	UB h14	WEIGHT (g)
32	26	10	45	22	13	45	48
40	28	12	52	25	16	52	75
50	32	12	65	27	16	60	124
63	40	16	75	32	21	70	192
80	60	16	95	36	22	90	380
100	70	20	115	41	27	110	620
125	90	25	140	50	30	130	1180
160	90	30	180	55	35	170	1780
200	110	30	220	60	35	170	2900

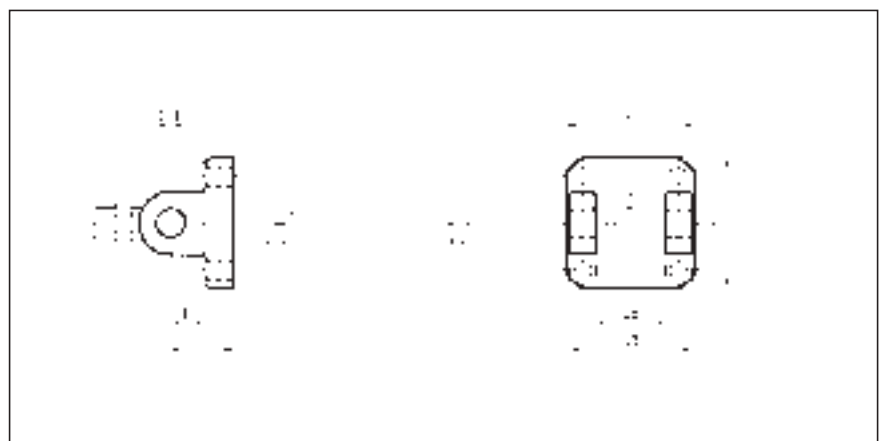

1

Accessories
**CPUI - Fixings for cylinders
to ISO 15552 standard Ø 32 ÷ 320**

REAR FEMALE HINGE
(Supplied with screws)

- ALUMINIUM (BUSHING AS STANDARD FOR Ø 32 ÷ 200) - CPUI/CF Ø
- STEEL - CPUI/CF Ø AC

Ø	CB H14	CD H9	E	FL	L	L4	UB h14
32	26	10	45	22	13	5,5	45
40	28	12	52	25	16	5,5	52
50	32	12	65	27	16	6,5	60
63	40	16	75	32	21	6,5	70
80	50	16	95	36	22	10	90
100	60	20	115	41	27	10	110
125	70	25	140	50	30	10	130
160	90	30	180	55	35	10	170
200	90	30	220	60	35	11	170
250	110	40	268	70	59	11	200
320	120	45	340	80	65	15	220

Ø	XD	WEIGHT ALL. (g)	WEIGHT STEEL (g)
32	142	48	138
40	160	75	230
50	170	124	338
63	190	192	540
80	210	380	1000
100	230	620	1700
125	275	1180	3350
160	315	1780	5750
200	335	2900	8900
250	375	5800	15900
320	420	-	30750

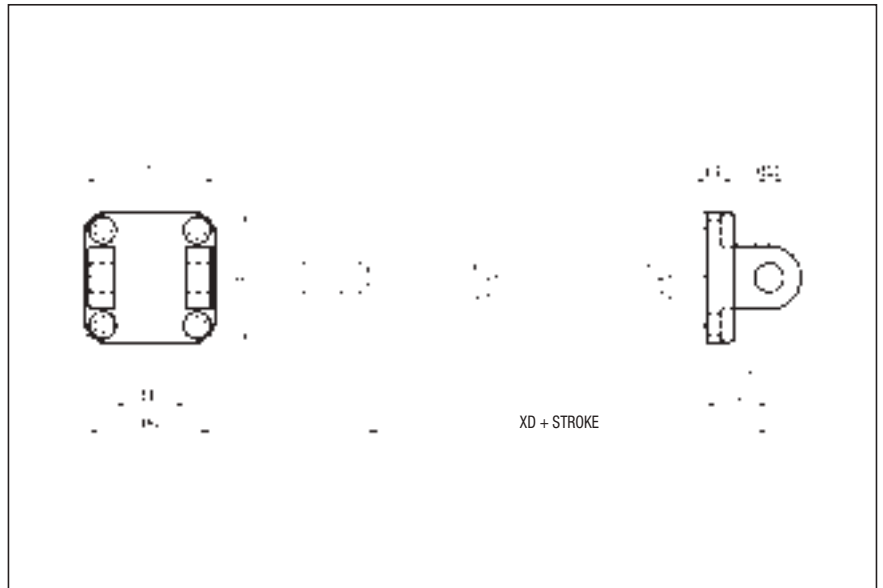

PIVOT FOR REAR FEMALE HINGE - ZINC-PLATED STEEL - CPU/CPUI/SEC Ø

Ø	BU	EK f7	EL	WEIGHT (g)
32	53	10	46	32
40	60	12	53	52
50	68	12	61	60
63	78	16	71	122
80	98	16	91	152
100	118	20	111	290
125	139	25	132	530
160	178	30	171,5	978
200	178	30	171,5	978
250	211	40	202	2100
320	236	45	222	2950

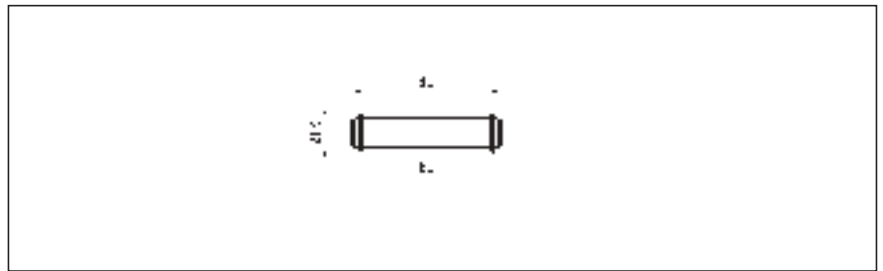

MALE HINGE

- ALUMINIUM (BUSHING AS STANDARD FOR Ø 32 ÷ 200) - CPUI/CM Ø
- STEEL - CPUI/CM Ø AC

(Supplied with screws)

Ø	CD H9	E	EW	FL	L	L4	XD
32	10	45	26	22	13	5,5	142
40	12	52	28	25	16	5,5	160
50	12	65	32	27	16	6,5	170
63	16	75	40	32	21	6,5	190
80	16	95	50	36	22	10	210
100	20	115	60	41	27	10	230
125	25	140	70	50	30	10	275
160	30	180	90	55	35	10	315
200	30	220	90	60	35	11	335
250	40	268	110	70	47	11	375
320	45	340	120	80	52	15	420

Ø	WEIGHT ALL. (g)	WEIGHT STEEL (g)
32	54	176
40	76	274
50	124	368
63	212	682
80	420	1196
100	666	2100
125	1264	3740
160	1846	5890
200	2950	8470
250	6200	16850
320	-	31750

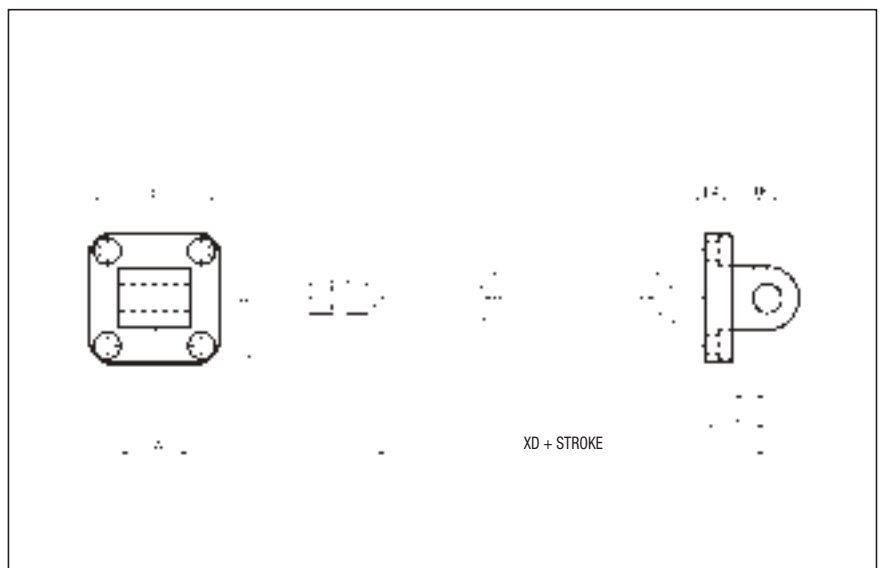

Accessories

CPUI - Fixings for cylinders to ISO 15552 standard Ø 32 ÷ 320

SQUARE JOINT

- ALUMINIUM (BUSHING AS STANDARD FOR Ø 32 ÷ 200) - CPUI/AS Ø
- STEEL - CPUI/AS Ø AC (Ø 32 ÷ 125)

Ø	PH JS15	CK H9	EM	GL JS14	RA JS14	UR	BT	L5
32	32	10	26	21	18	31	8	1,6
40	36	12	28	24	22	35	10	1,6
50	45	12	32	33	30	45	12	1,6
63	50	16	40	37	35	50	14	1,6
80	63	16	50	47	40	60	14	2,5
100	71	20	60	55	50	70	17	2,5
125	90	25	70	70	60	90	20	3,2
160	115	30	90	97	88	126	25	4
200	135	30	90	105	90	130	30	4
250	165	40	110	128	110	160	35	4,5

Ø	BR	S5 H13	K1 JS14	K2	XD	WEIGHT ALL. (g)	WEIGHT STEEL (g)
32	10	6,6	38	51	142	56	158
40	11	6,6	41	54	160	139	238
50	13	9	50	65	170	142	418
63	15	9	52	67	190	200	526
80	15	11	66	86	210	312	1055
100	19	11	76	96	230	510	1510
125	22,5	14	94	124	275	826	3150
160	31,5	18	118	156	315	2600	-
200	31,5	18	122	162	335	3250	-
250	???	22	150	200	375	5700	-

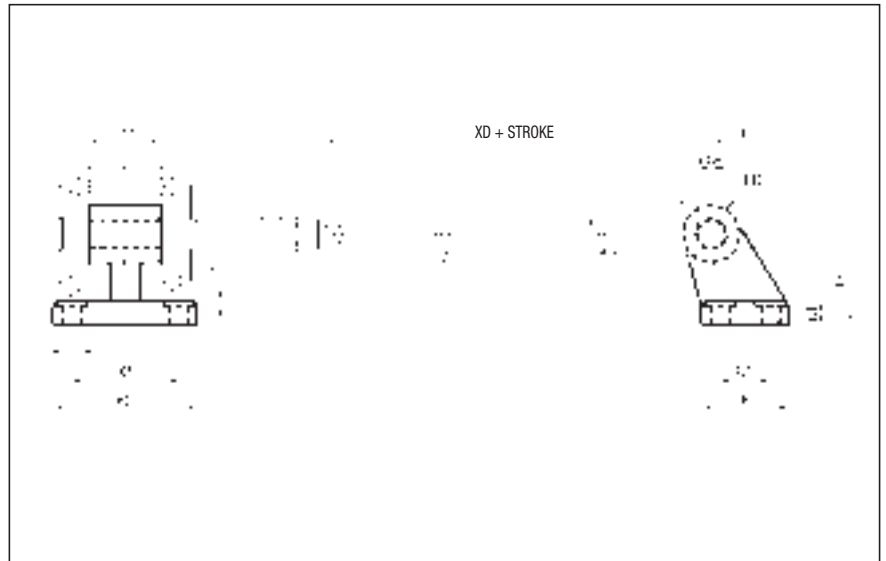

NARROW REAR FEMALE HINGE

(Supplied with screws)

- ALUMINIUM - CPUI/CFS Ø

- STEEL - CPUI/CFS Ø AC (Ø 32 ÷ 125)

Ø	CG D10	CP d12	B3	CF F7	E	FM	L10	L11
32	14	34	3,3	10	45	22	9	16,5
40	16	40	4,3	12	52	25	9	18
50	21	45	4,3	16	65	27	11	22
63	21	51	4,3	16	75	32	11	22
80	25	65	4,3	20	95	36	14	26
100	25	75	6,3	20	115	41	14	26
125	37	97	6,3	30	140	50	20	39
160	43	122	6,3	35	180	55	20	44
200	43	122	6,3	35	220	60	25	44
250	49	125	8,3	40	270	70	25	52

Ø	L4	XD	WEIGHT ALL. (g)	WEIGHT STEEL (g)
32	5,5	142	42	140
40	5,5	160	70	230
50	6,5	170	112	336
63	6,5	190	194	546
80	10	210	382	1190
100	10	230	610	1840
125	10	275	1100	3550
160	10	315	2030	-
200	11	335	3400	-
250	11	375	5400	-

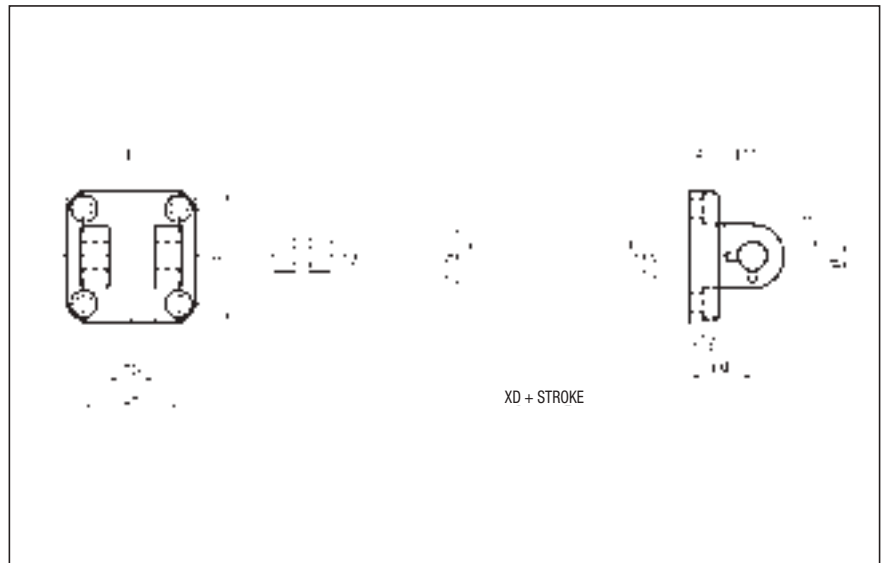

NON-ROTATING PIVOT FOR NARROW REAR FEMALE HINGE - GALVANIZED NITRIDED STEEL - CPUI/SEC Ø AT

Ø	d4 H12	JK f7	L8	ES	L9	L5	G	WEIGHT (g)
32	3	10	14	32,5	4,5	41	4	26
40	4	12	16	38	6	48	4	42
50	4	16	20	43	6	54	5	84
63	4	16	20	49	6	60	5	94
80	4	20	24	63	6	75	6	184
100	4	20	24	73	6	85	6	208
125	6	30	36	94	9	110	7	606
160	6	35	41	119	9	135	7	972
200	6	35	41	119	9	135	7	972
250	8	40	48	121	12	140	7	1365

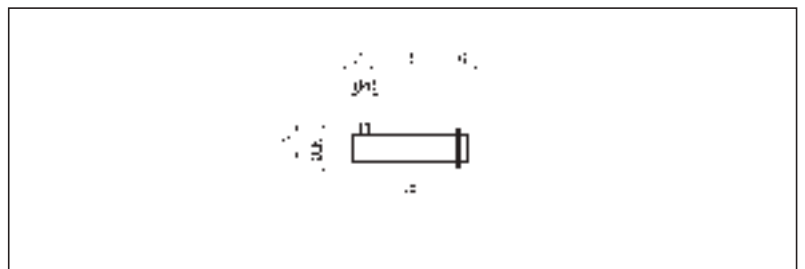

Accessories

CPUI - Fixings for cylinders to ISO 15552 standard Ø 32 ÷ 320

NARROW MALE HINGE WITH ARTICULATED HEAD (ISO 12240) (Supplied with screws)

- ALUMINIUM - CPUI/CMSS Ø
- STEEL - CPUI/CMSS Ø AC (Ø 32 ÷ 125)

Ø	CX H7	E	EN	MS	EU	G	DL
32	10	45	14	16	10,5	9	22
40	12	55	16	19	12	9	25
50	16	65	21	21	15	11	27
63	16	75	21	24	15	11	32
80	20	95	25	28,5	18	14	36
100	20	115	25	30	18	14	41
125	30	140	37	40	25	20	50
160	35	180	43	45	28	20	55
200	35	220	43	48	28	25	60
250	40	270	49	52	33	25	20

Ø	L4	XD	WEIGHT ALL. (g)	WEIGHT STEEL (g)
32	5,5	142	62	152
40	5,5	160	100	256
50	6,5	170	180	364
63	6,5	190	244	595
80	10	210	476	1122
100	10	230	646	1786
125	10	275	1410	3500
160	10	315	2420	-
200	11	335	3840	-
250	11	375	5850	-

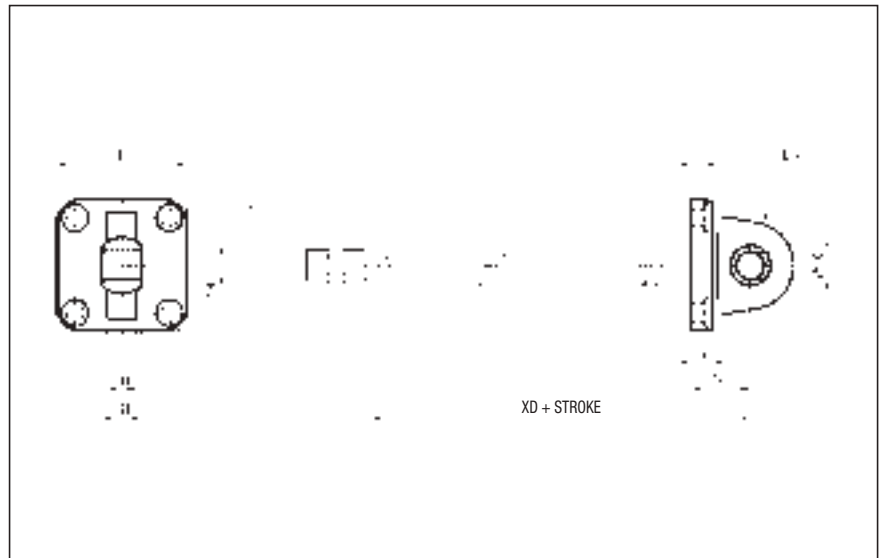

SQUARE JOINT WITH ARTICULATED HEAD (ISO 12240) - STEEL - CPUI/ASSS Ø AC

Ø	CA JS15	BQ	CK H7	EM	G1 JS14	G2 JS14	G3	H6
32	32	10,5	10	14	21	18	31	10
40	36	12	12	16	24	22	35	10
50	45	15	16	21	33	30	45	12
63	50	15	16	21	37	35	50	12
80	63	18	20	25	47	40	60	14
100	71	18	20	25	55	50	70	15
125	90	25	30	37	70	60	90	20

Ø	K1 JS14	K2	L5	R	S5 H13	XD	WEIGHT (g)
32	38	51	1,6	15	6,6	142	178
40	41	54	1,6	18	6,6	160	268
50	50	65	1,6	20	9	170	458
63	52	67	1,6	23	9	190	550
80	66	86	2,5	27	11	210	970
100	76	96	2,5	30	11	230	1326
125	94	124	3,2	40	13,5	275	3000

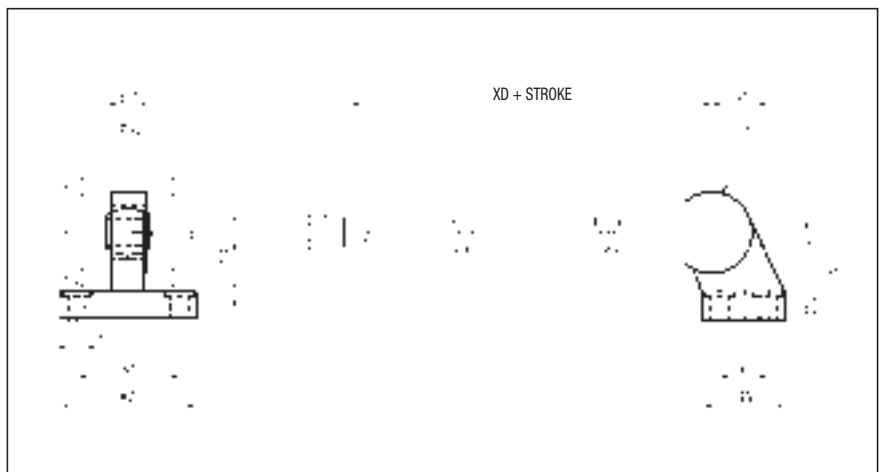

FLOATING HINGE - STEEL - CPUI/CTA Ø (Supplied with screws)

Ø	L1	LA	LB	TD e9	TL h14	TM h14	UW	WEIGHT (g)
32	14	19	127	12	12	50	46	137
40	19	20,5	144,5	16	16	63	59	385
50	19	27,5	152,5	16	16	75	69	513
63	24	25	170	20	20	90	84	1041
80	24	34	186	20	20	110	102	1563
100	29	36,5	203,5	25	25	132	125	3000
125	32	49	211	25	25	160	155	2100
160	40	75	280	32	32	200	190	4150
200	40	85	295	32	32	250	240	7350

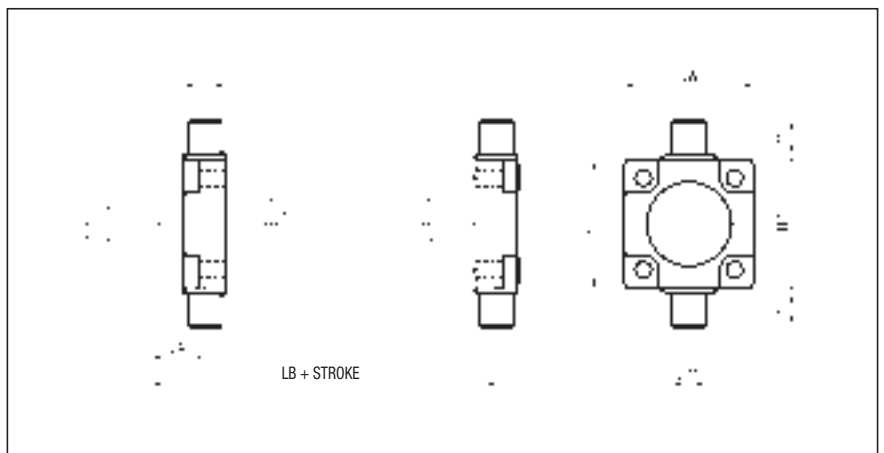

Accessories

CPUI - Fixings for cylinders to ISO 15552 standard Ø 32 ÷ 320

INTERMEDIATE HINGE - STEEL- X/CT Ø (Supplied with dowels)

Ø	TK	TD e9	TL h14	TM* 0/-Q3	UW1	UW2	XV min	XV max	WEIGHT (g)
32	25	12	12	49,5	65	49	65,5	80,5	177
40	25	16	16	61,7	75	62	73,5	91,5	325
50	30	16	16	74,6	95	74	82	98	433
63	30	20	20	87,8	105	88	87,5	107,5	668
80	30	20	20	105,8	130	109	97	123	1309
100	40	25	25	129,8	145	130	110	130	1817

*DIMENSION NOT STANDARDIZED

USABLE WITH CYLINDER SERIES X AND SERIES XT

P.S.: ADJUSTABLE POSITION (fixing through dowels)

ASSEMBLY: X/CT Ø + cylinder X
type **M/X/CT Ø**

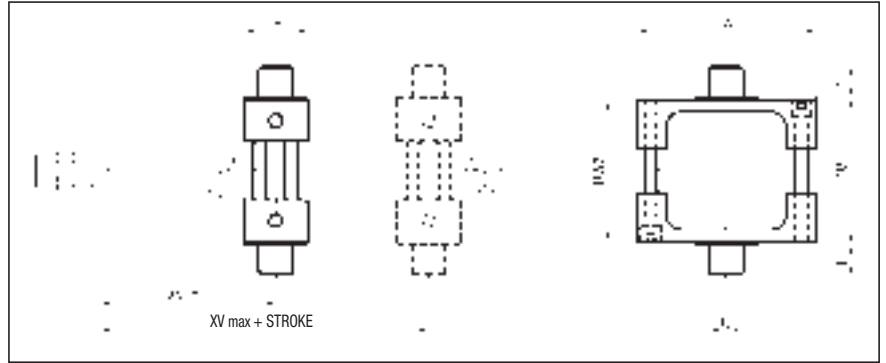

INTERMEDIATE HINGE - STEEL - EXTRUDED TUBE - XT-CT Ø (THREADED - ROUND)

Ø	TK	M	TD e9	TL h14	TM 0/-Q3	UW	XV min	XV max	WEIGHT (g)
32	15	M6	12	12	50	46	60,5	85,5	128
40	20	M6	16	16	63	59	71	96,5	308
50	20	M8	16	16	75	69	77	103	370
63	25	M8	20	20	90	84	85	110	690
80	25	M10	20	20	110	102	94,5	125,5	894
100	30	M10	25	25	132	125	105	135	1584

USABLE WITH CYLINDER SERIES XT EXTRUDED TUBE (S14)

P.S.: - FIXED POSITION (specify dimension "XV", fixed on cylinder with completed threaded and galvanized tie rods type "S6", see on page 1.1)

ASSEMBLY (FIXED): XT/CT Ø + cylinder XT S6
type **MF/XT/CT Ø**

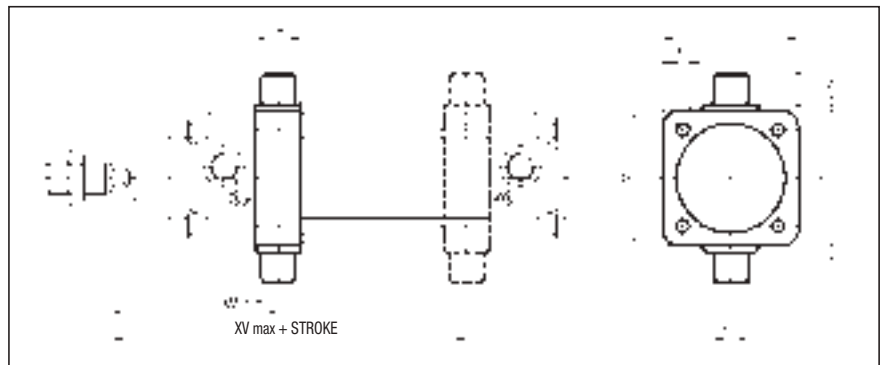

INTERMEDIATE HINGE - STEEL - EXTRUDED TUBE (Supplied with dowels)

- XT/CPUI/CT Ø 32 ÷ 100
- CX/CPUI/CT Ø 125 ÷ 320

Ø	TK	M	TD e9	TL h14	TM h14	UW	XV min	XV max	WEIGHT (g)
32	15	6,25	12	12	50	46	60,5	85,5	110
40	20	6,25	16	16	63	59	71	96,5	290
50	20	8,25	16	16	75	69	77	103	330
63	25	8,25	20	20	90	84	85	110	650
80	25	10,25	20	20	110	102	94,5	125,5	830
100	30	10,25	25	25	132	125	105	135	1560
125	32	12,25	25	25	160	155	127	163	2450
160	40	16,25	32	32	200	190	150	190	4150
200	40	16,25	32	32	250	240	163	207	7300
250	50	20,25	40	40	320	295	184	226	12920
320	70	24,25	50	50	400	370	212	248	25280

P.S.: - FIXED POSITION - Ø 125 ÷ 320 (specify dimension "XV", fixed on cylinder with completed threaded and galvanized tie rods type "S6", see on page 1.1)

ADJUSTABLE POSITION- Ø 32 ÷ 100 XT S14 (fixing through dowels)
- Ø 125 ÷ 200 XL (fixing through dowels)

ASSEMBLY (FIXED): CX/CPUI/CT Ø + cylinder CPUI S6
type **MF/CX/CPUI/CT Ø**

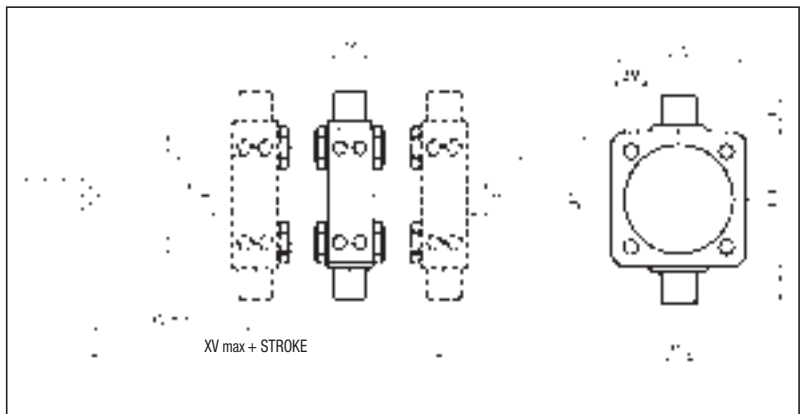

SUPPORT FOR INTERMEDIATE HINGE - STEEL - CPUI/SCT Ø

Ø	A	B1	B2	C	d1 F7	d2 H13	FN
32	32	46	18	10,5	12	6,6	30
40-50	36	55	21	12	16	9	36
63-80	42	65	23	13	20	11	40
100-125	50	75	28,5	16	25	14	50
160-200	60	92	40	22,5	32	18	60
250	90	140	56	31	40	22	90

Ø	XA	WEIGHT (g)
32	71	100
40-50	87-99	150
63-80	116-136	234
100-125	164-192	435
160-200	245-295	850
250	360	2750

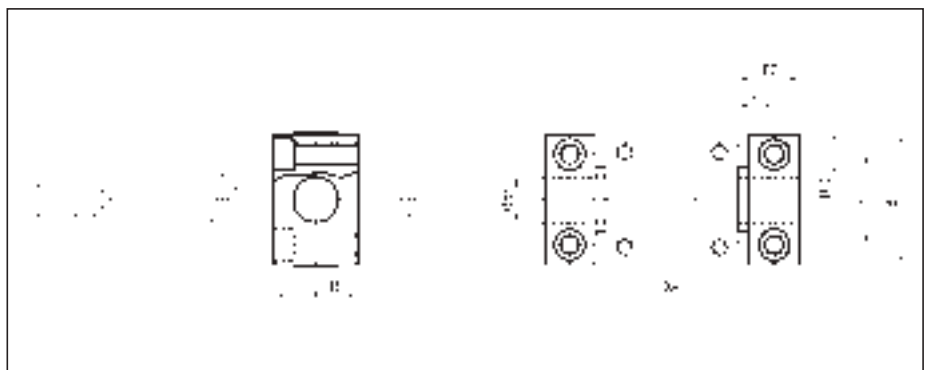

WBZ - Piston rod locking unit for cylinders to ISO 15552 standard

1

DESCRIPTION

Piston rod locking unit series "WBZ" is a mechanical device to fit on ISO 15552 cylinders (series X, XT and XL); its function is to lock the piston rod in any position. This solution allows to lock the cylinder stroke each time that there's a pressure fall. Locking force is, in any case, higher than the force given off by the cylinder fed at 10 bar. **ATTENTION:** It has static operation (cylinder piston rod not moving); it's necessary to preliminary stop the cylinder piston rod before proceeding with mechanical locking. It is possible to unblock the rod lock only if the forces in the piston are balanced, otherwise there can be accidents due to the irregular movement of the rod. If the given blocking values are exceeded there can be a sliding on the rod. When it is blocked and the loads are variable on the rod, the rod can have a slight axial play. Piston rod locking unit series "WBZ" must not be considered as a safety device.



TECHNICAL DATA

Operating pressure	3 ÷ 6 bar with cylinder feed pressure 1 ÷ 10 bar							
Working temperature	0 ÷ +80 °C (-5 °C with dry air)							
Fluid	Compressed air, filtered, continuous lubricated, unlubricated or dry lubricated							
Size	32, 40, 50, 63, 80, 100, 125							
Port size	32 ÷ 63 = G 1/8 80 ÷ 125 = G 1/4							
Locking type	Mechanical – Only axial (bi-directional)							
Release	Through pneumatic control							
Condition in absence of pressure	Locked							
Locking force with static load	Size	32	40	50	63	80	100	125
	N	790	1240	1930	3060	5400	7700	12040

ORDER KEY



ASSEMBLY

"WBZ" + cylinder series "X", "XT" or "XL" (Ø 125), "Z" version	M/WBZ
--	--------------

WBZ PISTON ROD LOCKING UNIT

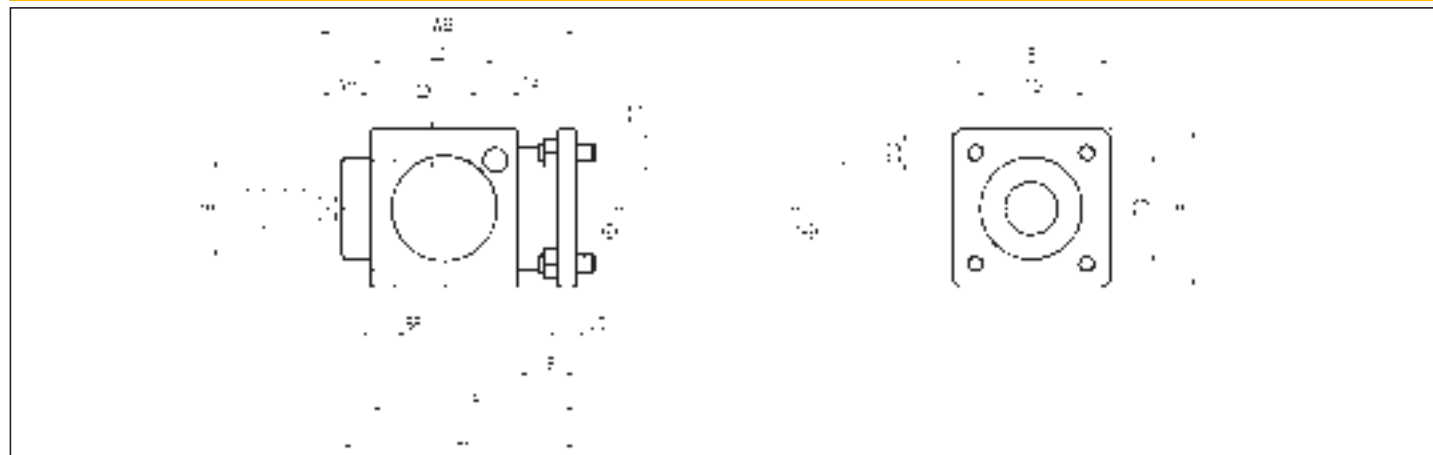

DIMENSIONS AND WEIGHTS

SIZE	B	BE	E	DA	DD	HD	L3	LA	LB	LC	LD	TG	WB	WH	WEIGHT (g)
32	30	8	47	G 1/8	M6	9	67,5	60	20	6	33,25	32,5	86	26	400
40	34,9	8	54	G 1/8	M6	9	80	70	20	6	42,5	38	100	30	600
50	40	12	65	G 1/8	M8	12,5	100	90	24	8	58	46,5	127	37	1100
63	45	12	75	G 1/8	M8	17,5	100	90	24	8	59	56,5	127	37	1500
80	45	16	95	G 1/4	M10	17,5	120	110	32	12	69	72	156	46	2600
100	55	16	114	G 1/4	M10	20	120	110	32	12	69	89	161	51	3500
125	60	20	138	G 1/4	M12	19	156	140	45	20	84,5	110	205	65	6500

P.S.: TECHNICAL INFORMATION (see the same ones for cylinders series "U" on page 1.7)

Accessories

WUG - Guide unit for cylinders to ISO 15552 standard Ø 32 ÷ 63

DESCRIPTION

Guide unit series "WUG" for cylinders to ISO 15552 standard (serie X e XT) act as devices against rotation of the piston rod in the presence of torques and they are used to carry out multi-axis systems where high movement precision is required. Guide units are available in single and double version, and are supplied with self-lubricating bushings (for low speeds or heavy loads), or with recirculating ball bearing sleeves (for high speeds).



1

TECHNICAL DATA

Working temperature	0 ÷ +80 °C
Size	32, 40, 50, 63
Standard strokes (mm)	25, 50, 100, 150, 200, 250, 300, 350, 400, 500
Versions	Single unit Double unit

MATERIALS

Body	Anodized aluminium alloy
Self-aligning radial joint	Steel
Adjustable mechanical stop as standard	Brass
End flanges	Single unit: galvanized steel Double unit: anodized aluminium alloy
Guide bars	C45 chromium-plated steel (sliding type on bushings); Hardened steel (sliding type with sleeves)
Bushings	Self-lubricating sintered bronze with wiper ring
Sleeves	Recirculating ball bearings with wiper ring
Clamp	Brass
Scrapers	NBR rubber

ORDER KEY

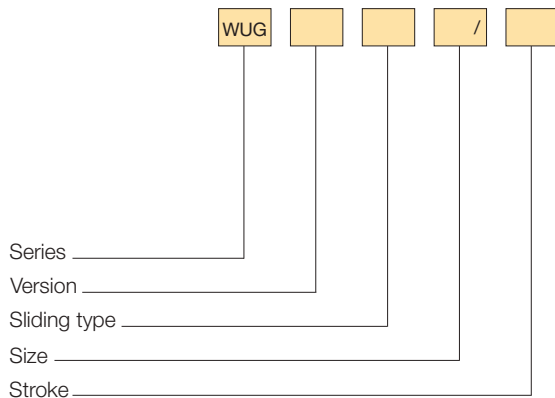

VERSION

Single unit _____ D Double unit

SLIDING TYPE

B On bushings _____ M With sleeves

ORDER EXAMPLES

Single guide unit, size 63, 150 mm stroke, with sleeves + cylinder series "X" Ø 63, double acting, 150 mm stroke, magnetic piston type, ASSEMBLED:
WUGM 63/150 + 63/150 X/M + M/WUG

Single guide unit, size 40, 250 mm stroke, with sleeves:
WUGM 40/250

Double guide unit, size 50, 100 mm stroke, with bushings:
WUGDB 50/100

ASSEMBLY

"WUG" + cylinders series "X" or "XT" **M/WUG**

TECHNICAL INFORMATION

1

WUG SINGLE GUIDE UNIT

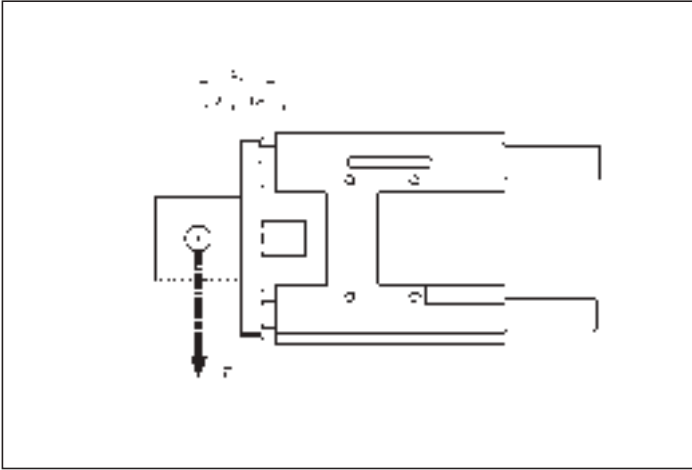

WUGD DOUBLE GUIDE UNIT

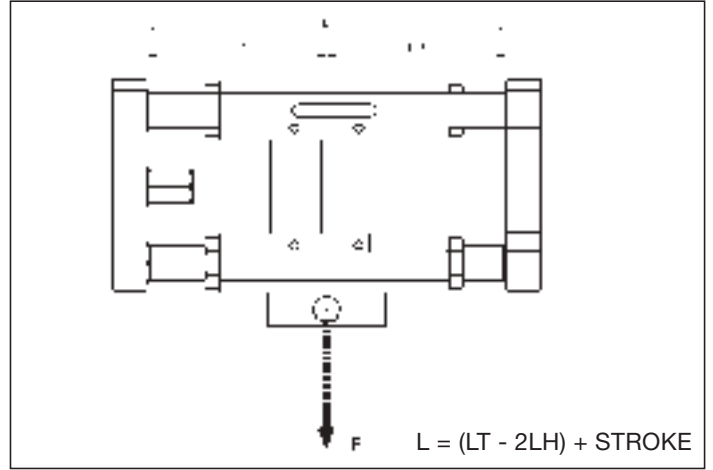

MAXIMUM PERMISSIBLE LOAD-WUG VERSION B

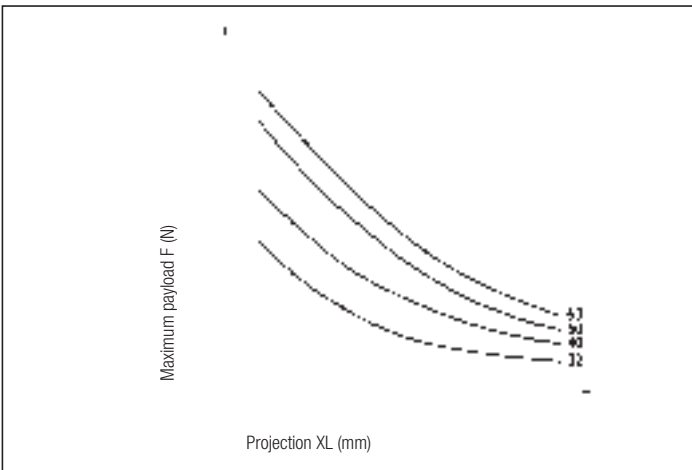

MAXIMUM PERMISSIBLE LOAD-WUGD VERSION B

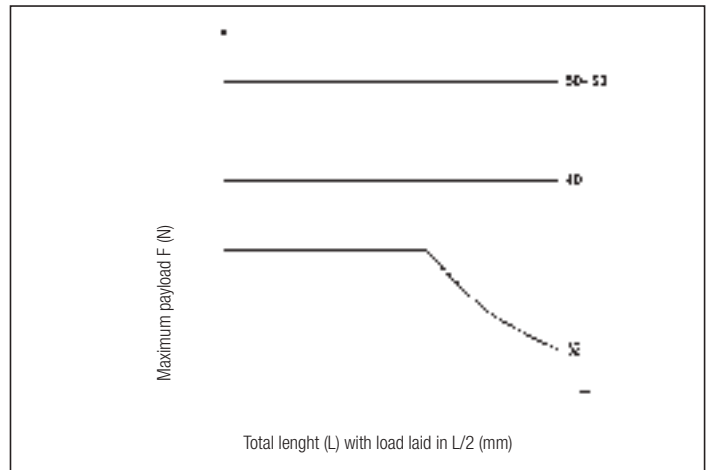

MAXIMUM PERMISSIBLE LOAD-WUG VERSION M

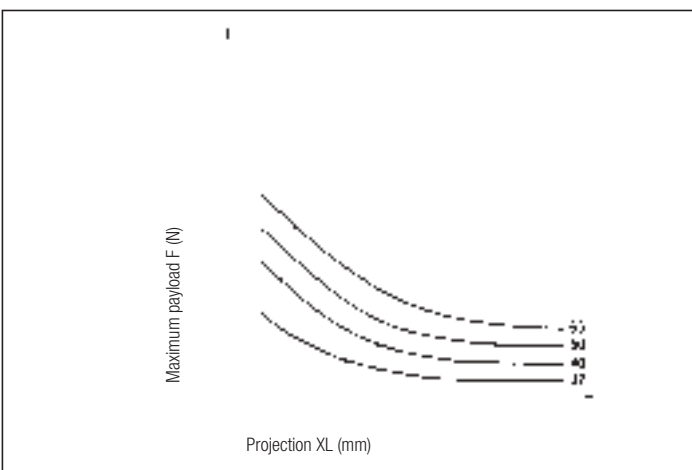

MAXIMUM PERMISSIBLE LOAD-WUGD VERSION M

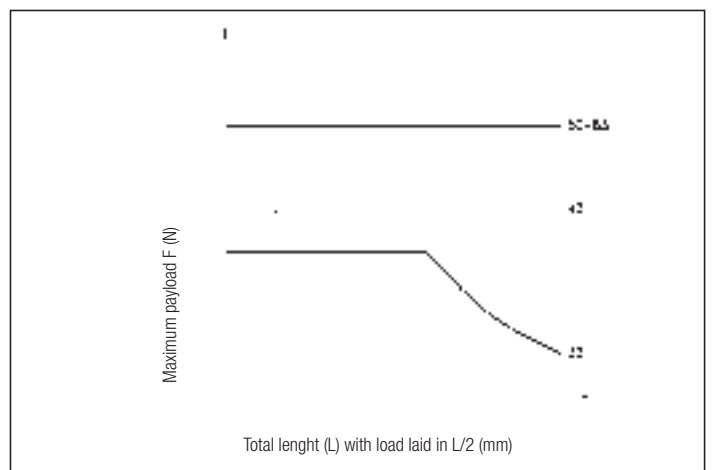

Accessories

WUG - Guide unit for cylinders to ISO 1552 standard Ø 32 ÷ 63

WUG SINGLE GUIDE UNIT

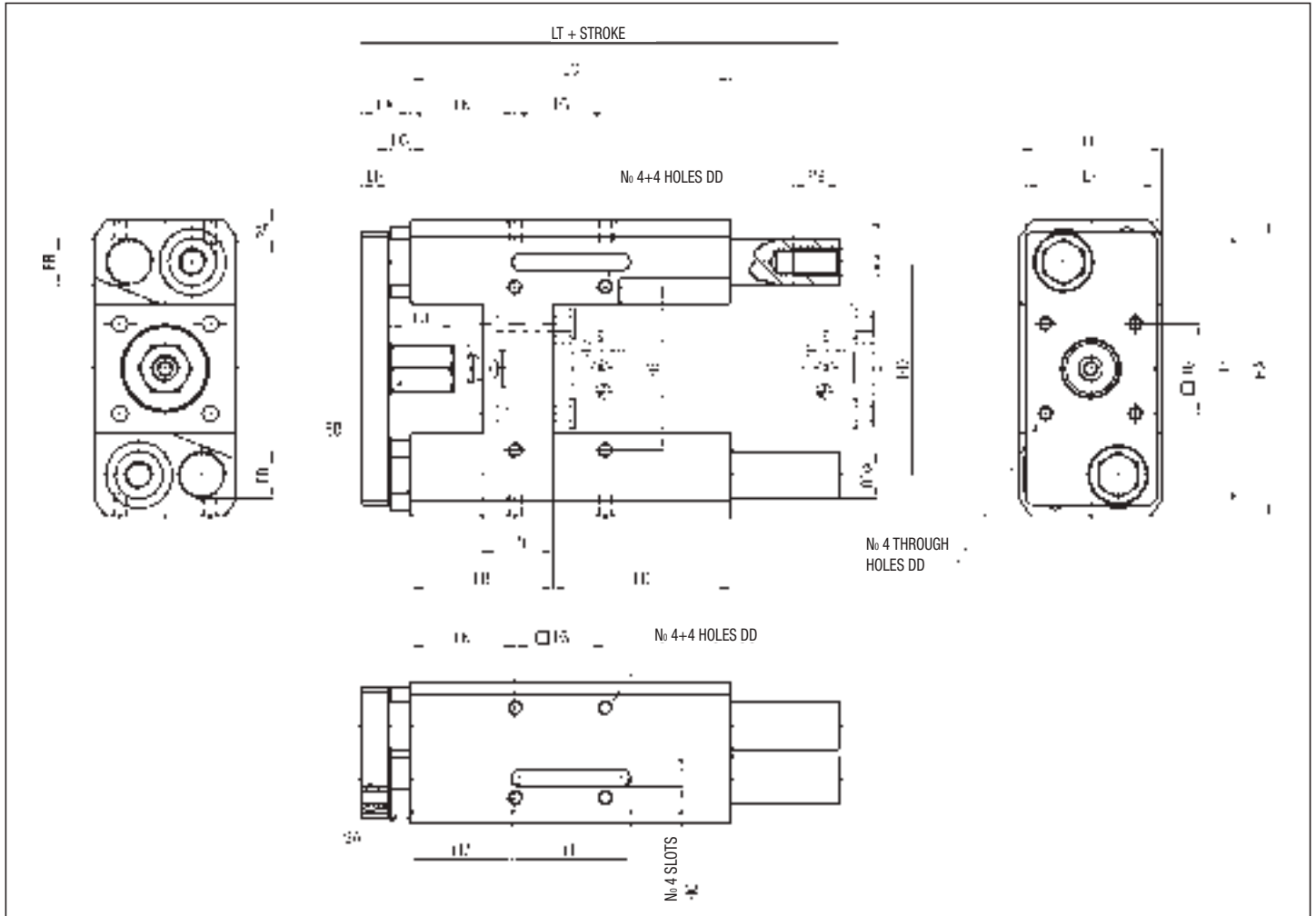

DIMENSIONS AND WEIGHTS

SIZE	DA	DD	FA	FB	HA	HB	HC	HD	HE	LA	LB	LC	LD	LE	LF	LG	LH
32	16	M6	M10x1,25	M18x1,5	112	100	7	79	61	20	50	120	70	50	45	8	12
40	20	M6	M12x1,25	M20x1,5	125	115	7	90	69	21	60	135	75	60	55	9	12
50	25	M8	M16x1,5	M24x2	150	144	7	108	85	25	70	150	80	70	65	10	15
63	25	M8	M16x1,5	M27x2	162	155	7	119	100	27	73	180	107	80	75	12	15

SIZE	LJ	LK	LL	LM	LN	LT	PA	PB	SA	SB	TG	WEIGHT WUGB (g)	INCREM. (g) every 10 mm	WEIGHT WUGM (g)	INCREM. (g) every 10 mm
32	22	38	50	34,5	25	157	6	15	Ch.23	Ch.17	32,5	2060	29	1815	31
40	27	44	50	42,5	30	172	8	20	Ch.26	Ch.20	38	2905	45	2760	50
50	32	47	50	50	35	190	8	25	Ch.30	Ch.20	46,5	4780	65	4525	76
63	32	49,5	50	65	35	225	9,5	25	Ch.36	Ch.20	56,5	6315	65	5950	87

CLAMP FOR DECELERATOR - WUGCD SIZE

SIZE	FA	FB	L	WEIGHT (g)
32	M18x1,5	M12x1	40	50
40	M20x1,5	M14x1,5	45	60
50	M24x2	M16x1,5	50	105
63	M27x2	M20x1,5	60	130

CLAMP FOR MAGNETIC PROXIMITY SWITCH - WUGCP SIZE

SIZE	FA	FB	L	WEIGHT (g)
32	M18x1,5	M12x1	40	47
40	M20x1,5	M12x1	40	67
50	M24x2	M12x1	45	128
63	M27x2	M12x1	45	173

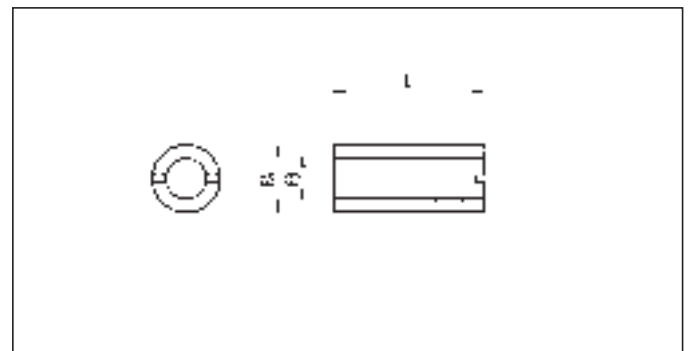

WUGD DOUBLE GUIDE UNIT

1

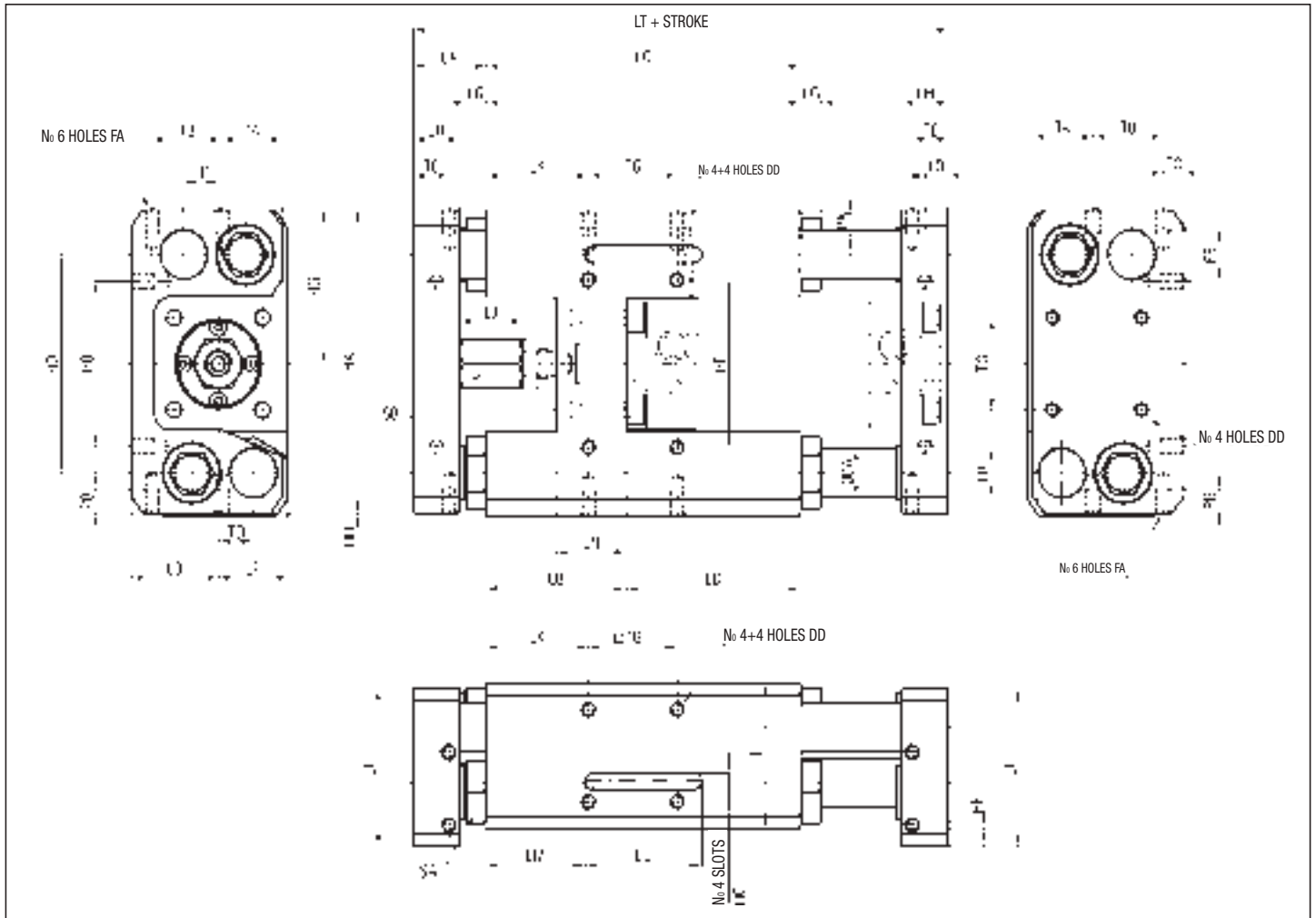

DIMENSIONS AND WEIGHTS

SIZE	DA	DD	FA	FB	HA	HB	HC	HD	HE	HF	HG	HH	LA	LB	LC	LD	LE
32	16	M6	M5	M18x1,5	112	60	7	79	61	1	57	1	28,5	50	120	70	50
40	20	M6	M6	M20x1,5	125	68	7	90	69	2,5	63,5	1	31,5	60	135	75	60
50	25	M8	M8	M24x2	150	79	7	108	85	1	76	1	37,5	70	150	80	70
63	25	M8	M8	M27x2	162	89	7	119	100	1	82	1	39,5	73	180	107	80

SIZE	LF	LG	LH	LJ	LK	LL	LM	LN	LO	LP	LQ	LT	PA	PB	SA	SB	TA
32	58	8	18	22	38	50	34,5	25	34	25	9	181	6	10	Ch.23	Ch.17	24
40	65	9	20	27	44	50	42,5	30	37,5	30	10	200	8	10	Ch.26	Ch.20	26
50	78,5	10	25	32	47	50	50	35	44,5	35	12,5	225	8	12	Ch.30	Ch.20	33,5
63	93	12	25	32	49,5	50	65	35	54	40	12,5	260	9,5	12	Ch.36	Ch.20	40

SIZE	TB	TC	TD	TE	TG	WEIGHT WUGDB (g)	INCREM. (g) every 10 mm	WEIGHT WUGDM (g)	INCREM. (g) every 10 mm
32	24,5	9,5	9,5	14	32,5	2320	29	2250	31
40	30	9	11,5	15,5	38	3480	45	3340	50
50	33	12	13	19	46,5	5750	65	5480	76
63	41	12	17	19	56,5	6445	65	6065	87

Accessories HS - Hydraulic speed regulators for cylinders to ISO 15552 standard Ø 40 ÷ 100

DESCRIPTION

Hydraulic regulators series "HS" assure a constant speed of pneumatic cylinders during their working cycle. In fact in the control of tools, that during their movements meet different resistances (i.e. violent impacts and vibrations) with the consequent variation of speed due to the use of only pneumatic control, you could obtain coarse finishes of the tooling till reach the breaking of the same tool. The hydraulic speed regulators exploit the oil incompressibility that, passing from a chamber to another one through an externally adjustable flow regulator, manages to uniform the speed and, with the use of control valves, avoids dead times warranting perfectly repeatable stops independently from the applied load. The adjustment can be made during the piston rod thrust phase, retract phase or both. The stop valve (STOP), mounted in-line on the circuit, and the acceleration valves (SKIP), mounted in-parallel, can be inserted in both the phases. These are poppet valves, two port, pneumatically actuated and therefore they have to be operated to make the STOP valve insert and to cut out the SKIP one.



1

TECHNICAL DATA

Working temperature	0 ÷ +70 °C
Fluid	Hydraulic oil (WAIRSOL HS: contact our commercial office for details)
Versions	In-line tank, piston rod thrust adjustment; In-parallel tank, piston rod thrust adjustment; In-parallel tank, piston rod retract adjustment; In-parallel tank, double adjustment
Bore	Ø 40
Standard strokes (mm)	50, 100, 150, 200, 250, 300, 350, 400, 450, 500
Maximum stroke (mm)	1000
Maximum adjustable load	6000 N
Minimum/Maximum permissible speed (mm/min)	Without valves: 60 ÷ 10.000 With valves: 0 ÷ 6.000

MATERIALS

End caps	Anodized aluminium alloy
Cylinder barrel	Drawn steel
Piston rod	C45 chromium-plated steel
Piston	Anodized aluminium alloy
Piston seal	NBR rubber
Piston rod seal	Polyurethane
Tie rods	Steel
Adjusting groups	Nickel-plated brass
Oil lever stick	Anodized aluminium alloy

ORDER KEY

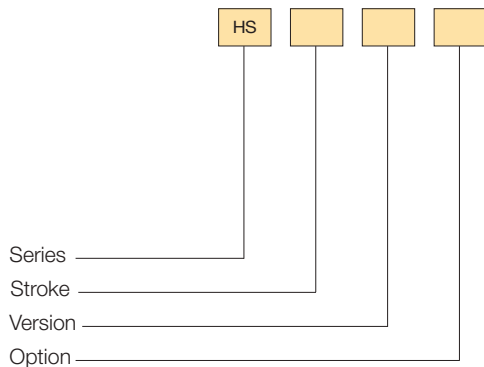

VERSION

LU	In-line tank, piston rod thrust adjustment
PU	In-parallel tank, piston rod thrust adjustment
PR	In-parallel tank, piston rod retract adjustment
PD	In-parallel tank, double adjustment

OPTION

1	Standard adjustment
2	STOP valve adjustment
3	SKIP valve adjustment
4	SKIP and STOP valves adjustment

ORDER EXAMPLES

Hydraulic regulator HS, 100 mm stroke, in-parallel tank, stop valve thrust adjustment: **HS100 PU2**

Hydraulic regulator HS, 150 mm stroke, in-parallel tank, skip valve double adjustment + cylinder series "XT" Ø63, 150 mm stroke, magnetic piston type + fixing plate + connection bridle + nipple + threaded bar, ASSEMBLED: **HS150PD3 + 63/150 XT/M + HS/PT63 + HS/BR50/63 + HS/NP 50/63 + HS/BF Ø + M/HS**

ASSEMBLY

"HS"+ cylinders series "X" or "XT"	M/HS
------------------------------------	------

Accessories HS - Hydraulic speed regulators for cylinders to ISO 15552 standard Ø 40 ÷ 100

1

IN-LINE TANK-THRUST ADJUSTMENT - HS..LU1

WEIGHT: 2200 G (0 MM-STROKE) + 61 G EVERY 10 MM OF STROKE

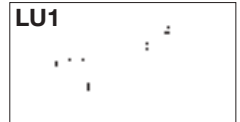
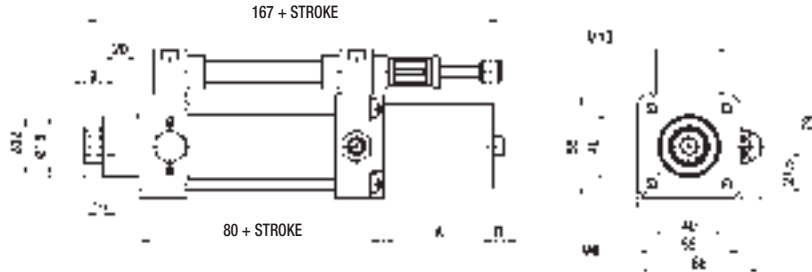

DIMENSIONS WITH IN-LINE TANK-THRUST ADJUSTMENT

STROKES (mm)	A	B (max)
≤ 75	75	25
76 ÷ 150	90	39
151 ÷ 250	142	65
251 ÷ 350	171	87
351 ÷ 500	222	125

IN-LINE TANK-THRUST ADJUSTMENT - HS..LU2 - HS..LU3

WEIGHT LU2: 2700 g (50 mm-STROKE) + 61 g EVERY 10 mm OF STROKE (MIN. STROKE 50 mm)
 WEIGHT LU3: 2300 G (0 MM-STROKE) + 61 G EVERY 10 MM OF STROKE (MIN. STROKE 50 MM)

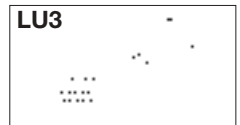
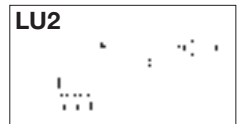
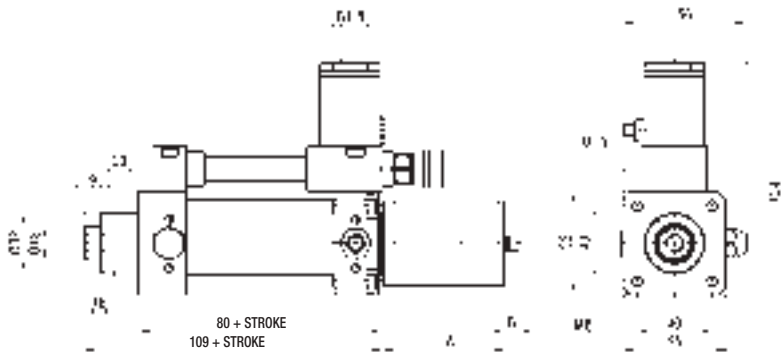

IN-LINE TANK-THRUST ADJUSTMENT - HS..LU4

WEIGHT: 2800 g (50 mm-STROKE) + 61 g EVERY 10 mm OF STROKE (MIN. STROKE 50 mm)

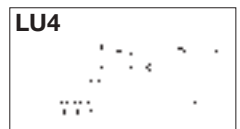
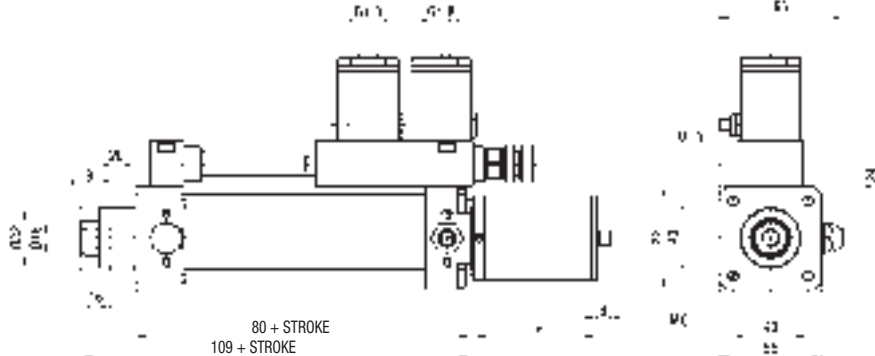

DIMENSIONS WITH IN-LINE TANK-THRUST ADJUSTMENT

STROKES (mm)	A	B (max)
≤ 75	60	25
76 ÷ 150	75	39
151 ÷ 250	127	65
251 ÷ 350	156	87
351 ÷ 500	205	125

Accessories HS - Hydraulic speed regulators for cylinders to ISO 15552 standard Ø 40 ÷ 100

1

IN-PARALLEL TANK-THRUST ADJUSTMENT - HS..PU1

WEIGHT: 2200 G (0 MM-STROKE) + 61 G EVERY 10 MM OF STROKE

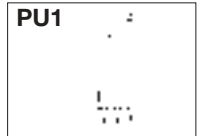
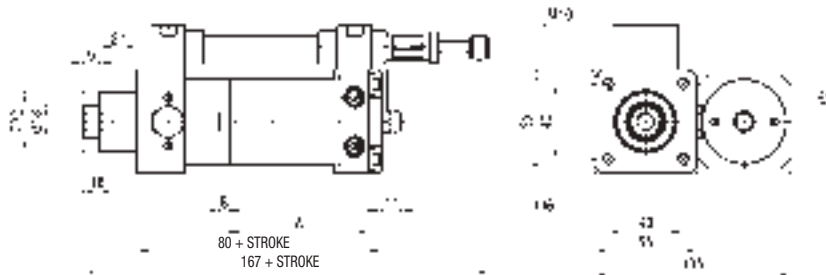

IN-PARALLEL TANK-THRUST ADJUSTMENT - HS..PU2 - HS..PU3

WEIGHT PU2: 2700 g (50 mm-STROKE) + 61 g EVERY 10 mm OF STROKE (MIN. STROKE 50 mm)
 WEIGHT PU3: 2300 G (0 MM-STROKE) + 61 G EVERY 10 MM OF STROKE (MIN. STROKE 50 MM)

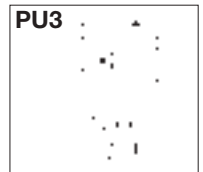
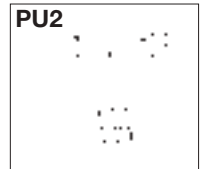
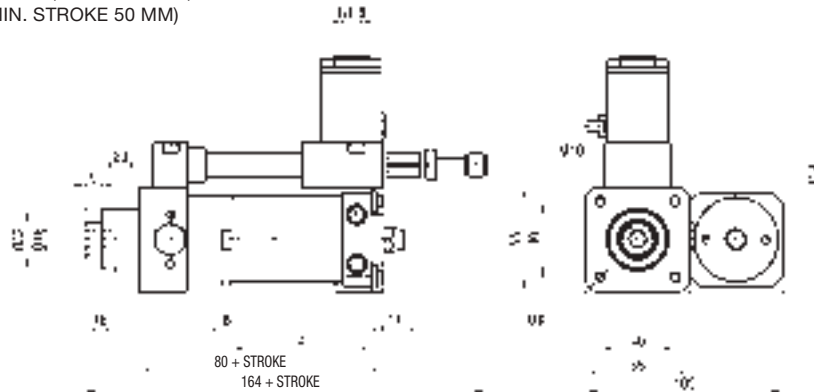

IN-PARALLEL TANK-THRUST ADJUSTMENT - HS..PU4

WEIGHT: 2800 g (50 mm-STROKE) + 61 g EVERY 10 mm OF STROKE (MIN. STROKE 50 mm)

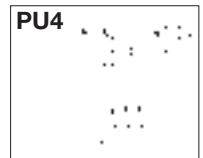
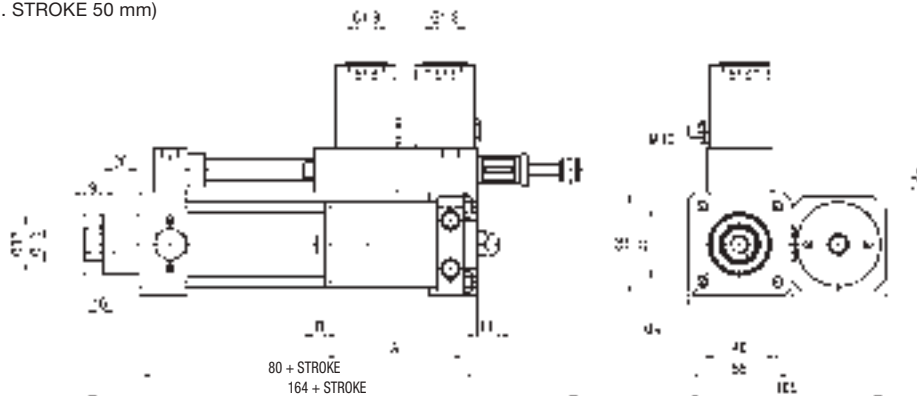

DIMENSIONS WITH IN-PARALLEL TANK-THRUST ADJUSTMENT

STROKES (mm)	A	B (max)
≤ 75	75	25
76 ÷ 150	90	39
151 ÷ 250	142	65
251 ÷ 350	171	87
351 ÷ 500	222	125

Accessories HS - Hydraulic speed regulators for cylinders to ISO 15552 standard Ø 40 ÷ 100

1

IN-PARALLEL TANK-RETRACT ADJUSTMENT - HS..PR1

WEIGHT: 2200 G (0 MM-STROKE) + 61 G EVERY 10 MM OF STROKE

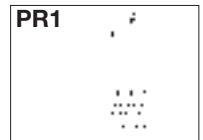
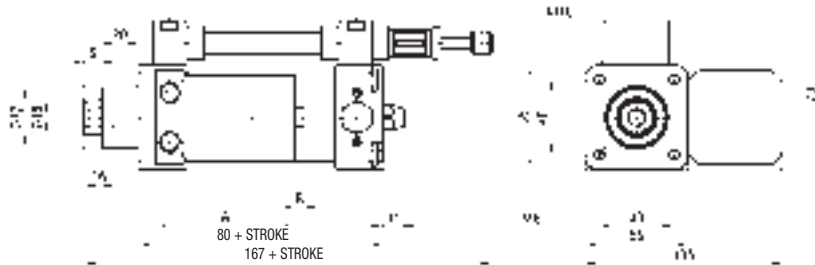

IN-PARALLEL TANK-RETRACT ADJUSTMENT - HS..PR2 - HS..PR3

WEIGHT PR2: 2700 g (50 mm-STROKE) + 61 g EVERY 10 mm OF STROKE (MIN. STROKE 50 mm)
WEIGHT PR3: 2300 g (0 mm-STROKE) + 61 g EVERY 10 mm OF STROKE (MIN. STROKE 50 mm)

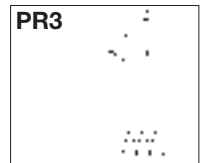
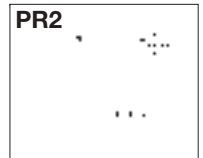
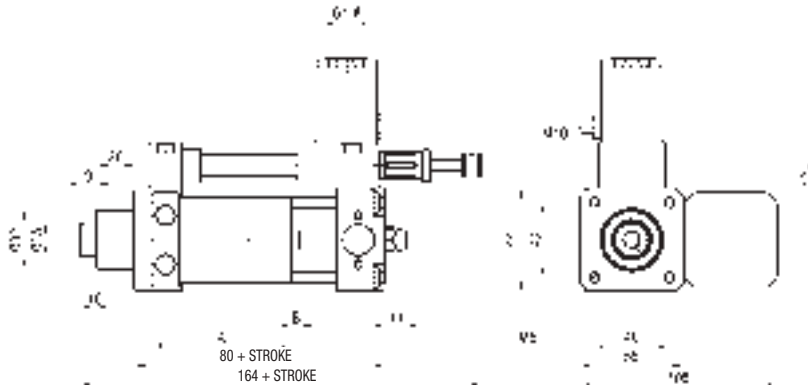

IN-PARALLEL TANK-RETRACT ADJUSTMENT - HS..PR4

WEIGHT: 2800 g (50 mm-STROKE) + 61 g EVERY 10 mm OF STROKE (MIN. STROKE 50 mm)

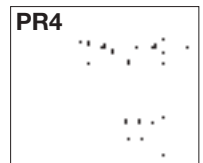
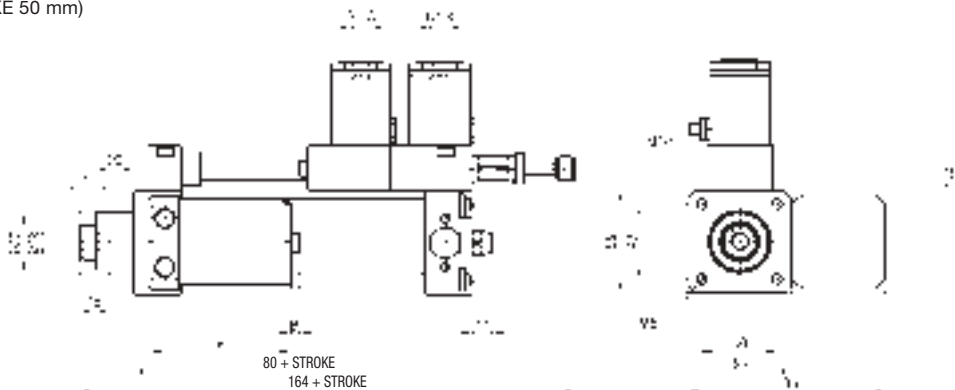

DIMENSIONS WITH IN-PARALLEL TANK-RETRACT ADJUSTMENT

STROKES (mm)	A	B (max)
≤ 75	75	25
76 ÷ 150	90	39
151 ÷ 250	142	65
251 ÷ 350	171	87
351 ÷ 500	222	125

Accessories HS - Hydraulic speed regulators for cylinders to ISO 15552 standard Ø 40 ÷ 100

1

IN-PARALLEL TANK-DOUBLE ADJUSTMENT HS..PD1

WEIGHT: 2900 g (50 mm-STROKE)
+ 61 g EVERY 10 mm OF STROKE
(MIN. STROKE 50 mm)

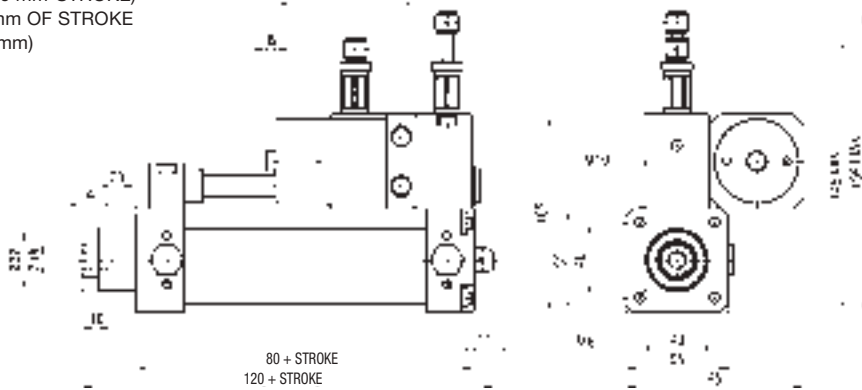

PD1

IN-PARALLEL TANK-DOUBLE ADJUSTMENT HS..PD2 - HS..PD3

WEIGHT PD2: 4100 g (150 mm-STROKE)
+ 61 g EVERY 10 mm OF STROKE
(MIN. STROKE 150 mm)

WEIGHT PD3: 3100 g (50 mm-STROKE)
+ 61 g EVERY 10 mm OF STROKE
(MIN. STROKE 50 mm)

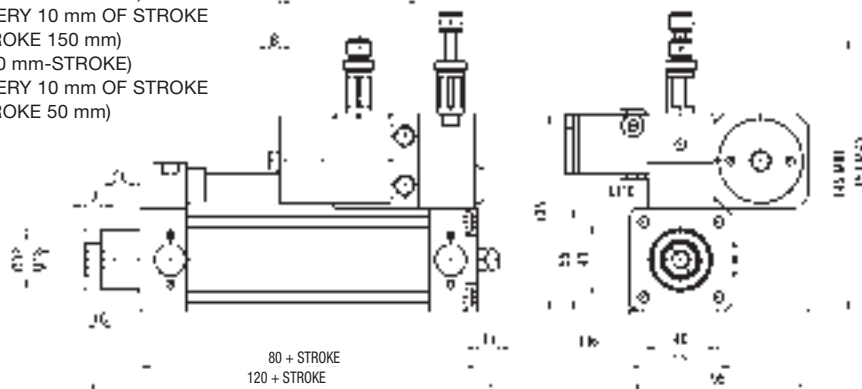

PD2

PD3

DIMENSIONS WITH IN-PARALLEL TANK-DOUBLE ADJUSTMENT

STROKES (mm)	A	B (max)
50 ÷ 75	75	25
76 ÷ 150	90	39
151 ÷ 250	142	65

STROKES (mm)	A	B (max)
251 ÷ 350	171	87
351 ÷ 500	222	125

IN-PARALLEL TANK-DOUBLE ADJUSTMENT HS..PD4

WEIGHT: 4300 g (150 mm-STROKE)
+ 61 g EVERY 10 mm OF STROKE
(MIN. STROKE 150 mm)

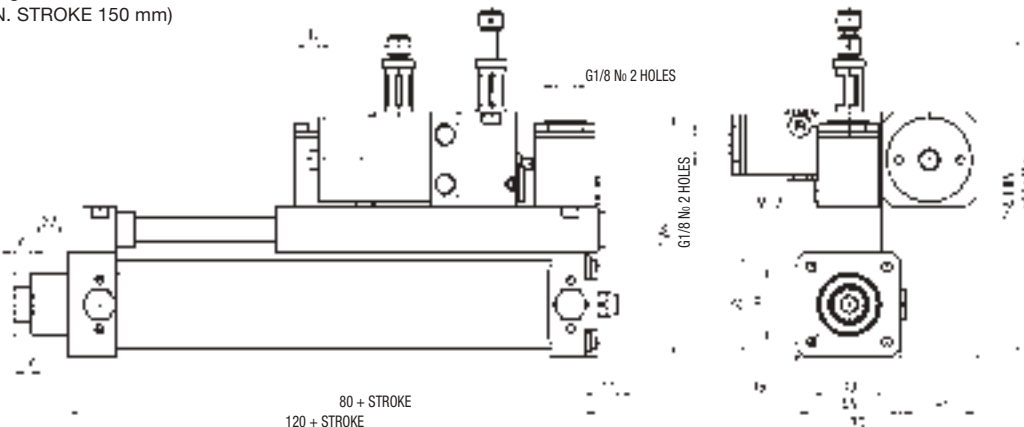

PD4

DIMENSIONS WITH IN-PARALLEL TANK-DOUBLE ADJUSTMENT

STROKES (mm)	A	B (max)
150 ÷ 250	142	65
251 ÷ 350	171	87
351 ÷ 500	222	125

Accessories HS - Hydraulic speed regulators for cylinders to ISO 15552 standard Ø 40 ÷ 100

1

FIXING PLATE HYDRAULIC REGULATOR/CYLINDERS SERIES "X" and "XT" - HS/PT Ø

Ø	B	DA	DB	DC	HA	LD	LF
40	35	32	6,5	6,5	55	111	56,5
50	40	32	6,5	8,5	65	122	62
63	45	32	6,5	8,5	75	132	67
80	45	32	6,5	10,5	95	152	77
100	55	32	6,5	10,5	115	171	86,5

Ø	LG	LH	LI	TG	WEIGHT (g)
40	27	40	10	38	315
50	32,5	40	10	46,5	430
63	37,5	40	12	56,5	666
80	47,5	40	12	72	1080
100	57	40	15	89	1879

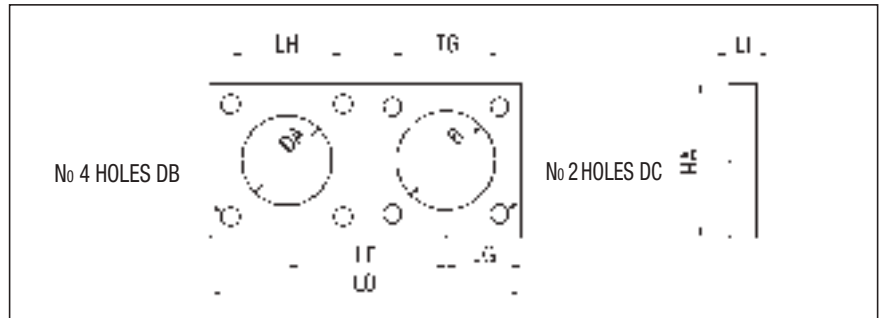

CONNECTION BRIDLE HYDRAULIC REGULATOR/CYLINDERS SERIES "X" and "XT" PISTON RODS - HS/BR Ø

Ø	HB	HC	HD	KK	LJ	LK	LL
40	80	25	25	M12x1,25	40	12	20
50 - 63	90	-	-	M16x1,5	40	12	15
80-100	117	-	-	M20x1,5	50	12	20

Ø	LN	LM	TA	TB	WEIGHT (g)
40	8	5	12	56	351
50 - 63	-	-	11,5	62	369
80-100	-	-	18	77	818

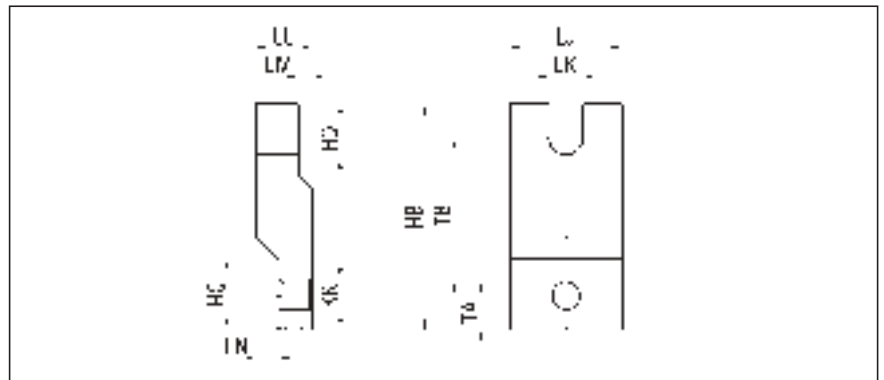

CYLINDERS SERIES "X" and "XT" RESTORATION THREAD NIPPLE- HS/NP Ø

Ø	AM	CH	KK	LO	PA	WEIGHT (g)
40	24	19	M12x1,25	47	14	59
50 - 63	32	24	M16x1,5	65	19	131
80-100	40	30	M20x1,5	78	24	245

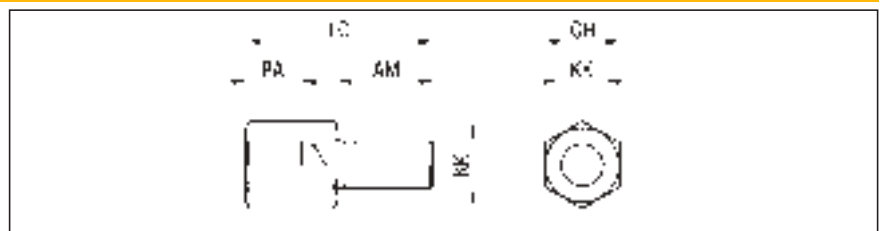

THREADED BAR - HS/BF Ø

Ø	LP	WEIGHT (g)
40	6	166
50 ÷ 100	8	178

P.S.: THREADED BAR IS SUPPLIED WITH 5 NUTS AND 2 WASHERS

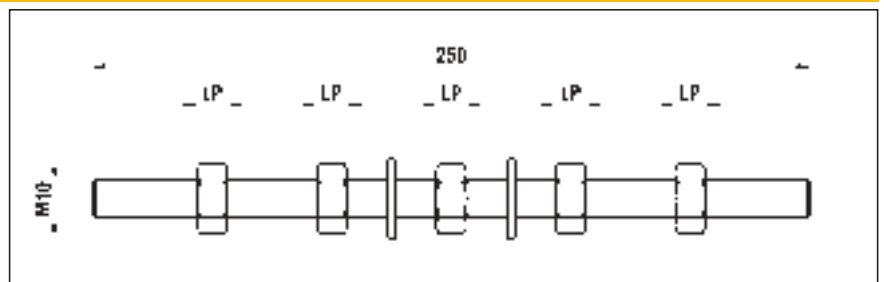

Accessories HS - Hydraulic speed regulators for cylinders to ISO 1552 standard Ø 40 ÷ 100

FIXATION HYDRAULIC REGULATOR/CYLINDERS SERIES "X" and "XT"

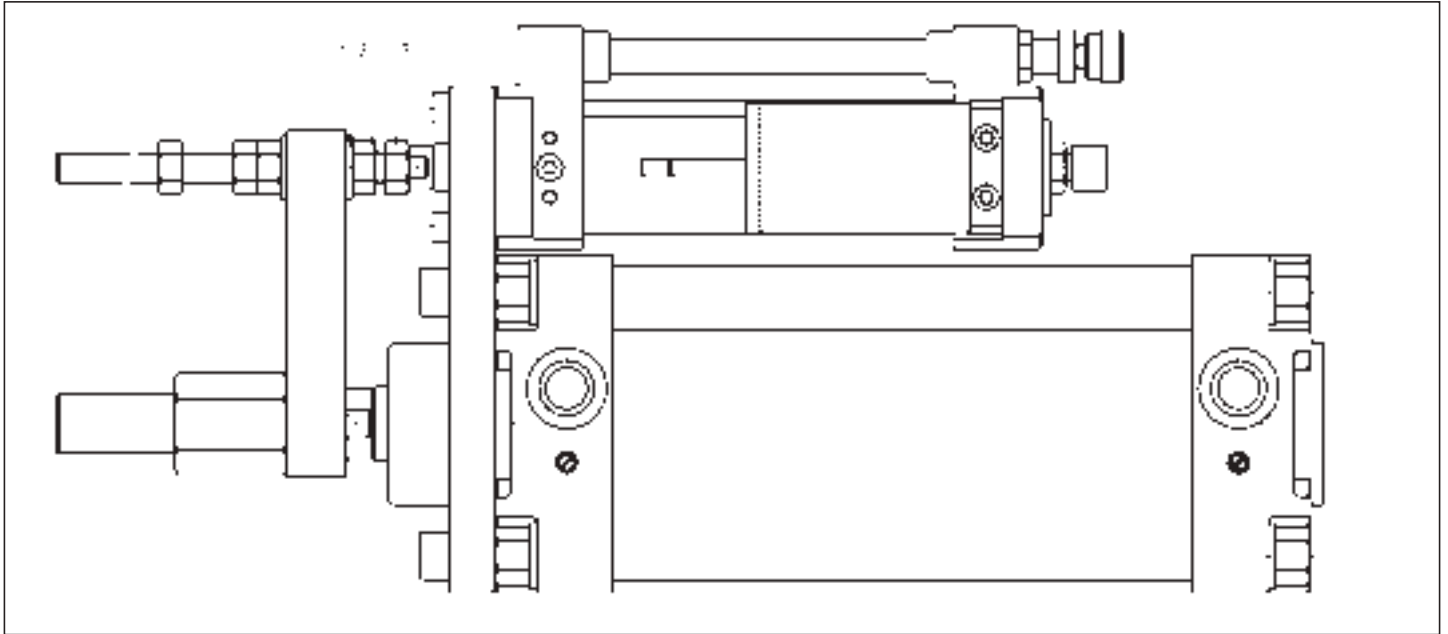

Ø	1	2	3
40 ÷ 63	-	X	-
80	-	X	X
100	X	X	X

P.S.: DO NOT TIGHTEN THE BRIDLE - THREADED BAR COUPLING

REINSTATEMENT PROCEDURE OF THE OIL LEVEL

HYDRAULIC SPEED REGULATORS ARE CLOSED CIRCUIT SYSTEMS SUPPLIED WITH A TANK FOR THE COMPENSATION OF THE ROD VOLUME. THIS TANK IS DESIGNED TO FACE LITTLE FLUID LOSSES DURING THE WORKING. IN THE EVENIENCE THAT DURING THE WORKING THE LEAKAGE OF OIL OVERCOME THE QUANTITY OF OIL IN EXCESS IN THE TANK, THE REGULATOR MUST BE REFILLED. THIS OPERATION MUST BE DONE WHEN THE INDICATOR NOTCH SITUATED ON THE DIP-STICK IN THE COMPENSATOR TANK IS NO MORE VISIBLE WHEN THE MAIN ROD IS COMPLETELY EXTENDED. TO REFILL THE HYDRAULIC SPEED REGULATOR USE A STANDARD GREASING SYRINGE, THAT CAN BE EASILY FOUND IN THE MARKET. THIS SYRINGE HAS TO BE CHARGED WITH "WAIRSOL HS" OIL.

REFILLING OPERATION:

- 1) PUT THE HYDRAULIC REGULATOR IN VERTICAL POSITION WITH THE FILLING VALVE, SITUATED ON THE REAR END CAP, THAT HAS TO BE HIGH-FACING.
- 2) EXTEND COMPLETELY THE HYDRAULIC REGULATOR PISTON ROD.
- 3) APPLY THE SYRINGE, FILLED WITH OIL, TO THE CONICAL SLOT OF THE FILLING VALVE ABOVE MENTIONED.
- 4) PUMP THE OIL IN THE REGULATOR WITH THE SYRINGE PAYING ATTENTION THAT THE SAME SHOULDN'T GO COMPLETELY EMPTY DURING THE RECHARGE (IF THIS OCCURS, STOP AND TOPPING UP THE SYRINGE).
- 5) CHARGE TILL THE MINIMUM NOTCH DOESN'T EXCEED THE LEVEL OF THE COMPENSATOR DIP-STICK PLUG OF 5 ÷ 8 mm.
- 6) OPERATE MORE TIMES THE REGULATOR MAIN PISTON ROD, TAKING CARE OF REGULATING THE CUSHIONINGS TO OBTAIN THE MAXIMUM SPEED.
- 7) WITH THE PISTON ROD COMPLETELY RETRACTED AND WITH THE CYLINDER ALWAYS IN VERTICAL POSITION, OPERATE THE CLOSING MUSHROOM OF THE FILLING VALVE WITH A SPIKY TOOL SO THAT POSSIBLE AIR BUBBLES CAN BLEED .
- 8) REPEAT THE OPERATIONS FROM POINT No. 2 TO POINT No. 7 TILL THE AIR IN THE CIRCUIT WILL BE COMPLETELY ELIMINATED.

1

DESCRIPTION

Stainless steel cylinders series "AX", and correspondent fixing accessories, comply with ISO 15552 standard and they are available from Ø 32 to Ø 200. They are cushioned and magnetic as "special" applications (for example food, chemical and pharmaceutical industries). They can comply with ATEX directive, 2GD category, upon request.



TECHNICAL DATA

Operating pressure	1 ÷ 10 bar
Working temperature	0 ÷ +80 °C (with dry air -20 °C) 0 ÷ +15 °C with seals for high temperature (with dry air -10 °C)
Fluid	Filtered, unlubricated, continuous lubricated or dry compressed air
Versions	Double acting, through rod
Bore	Ø 32, 40, 50, 63, 80, 100, 125, 160, 200
Port size	Ø 32 = G 1/8 Ø 40 - 50 = G 1/4 Ø 63 - 80 = G 3/8 Ø 100 - 125 = G 1/2 Ø 160 - 200 = G 3/4
Standard strokes (mm)	25, 50, 80, 100, 125, 160, 200, 250, 300, 320, 400, 500 600, 700, 800, 900, 1000
Decelerators lenght	Ø 32 40 50 63 80 100 125 160 200 mm 27 29 32 32 32 32 42 54 54
Maximum strokes (mm)	1000

MATERIALS

End caps	AISI 304 stainless steel
Cylinder barrel	Extruded tube, AISI 304 stainless steel
Tie rods, tie and rod nut	Ø 32 ÷ 100 AISI 316 stainless steel Ø 125 ÷ 200 AISI 304 stainless steel
Piston rod	AISI 316 stainless steel
Decelerator ogives	Ø 32 ÷ 100 Techno-polymer Ø 125 ÷ 200 Aluminium alloy
Piston rod bearing	Self lubricating sintered bronze
Piston	NBR rubber block (supplied with magnet)
Seals	Poliuretthane - FKM (Viton®)

ORDER KEY

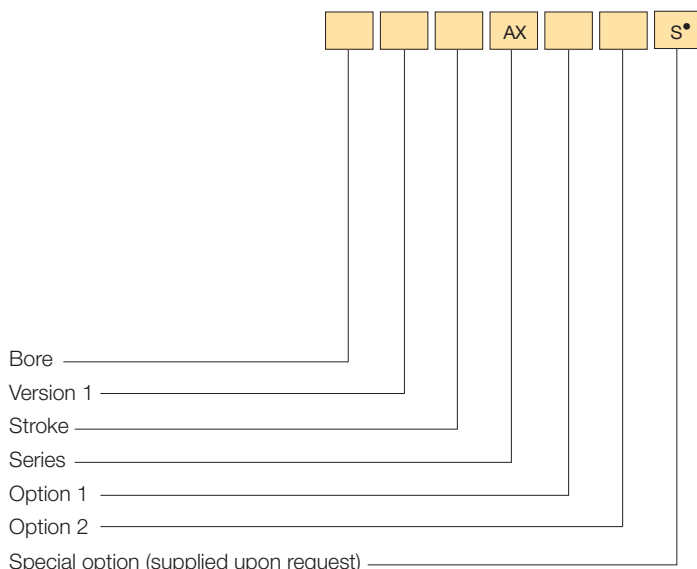

• See Chapter 1, page 1.1.

VERSION 1

/ Double acting R Through rod

OPTION 1

2 Seals for high temperature*

OPTION 2

/EX Consistent with the ATEX directive II 2GD c T5 T100°C -20°C < Ta < 80°C

* Available even with "FKM" (Viton®) seals but just for applications where is needed a chemical compatibility; not available for high temperatures.

ORDER EXAMPLES

Cylinder Ø 32, 100 mm stroke, double acting, ATEX: **32/100 AX/EX**

Cylinder Ø 40, 150 mm stroke, through rod, seals for high temperature: **40R150 AX2**

SPARE PARTS

SEALS KIT	
Polyurethane	Ø/SG/AX
Through rod polyurethane	Ø/SG/R/AX
For high temperature	Ø/SG/AX2
Through rod for high temperature	Ø/SG/R/AX2

AX BASIC CYLINDER

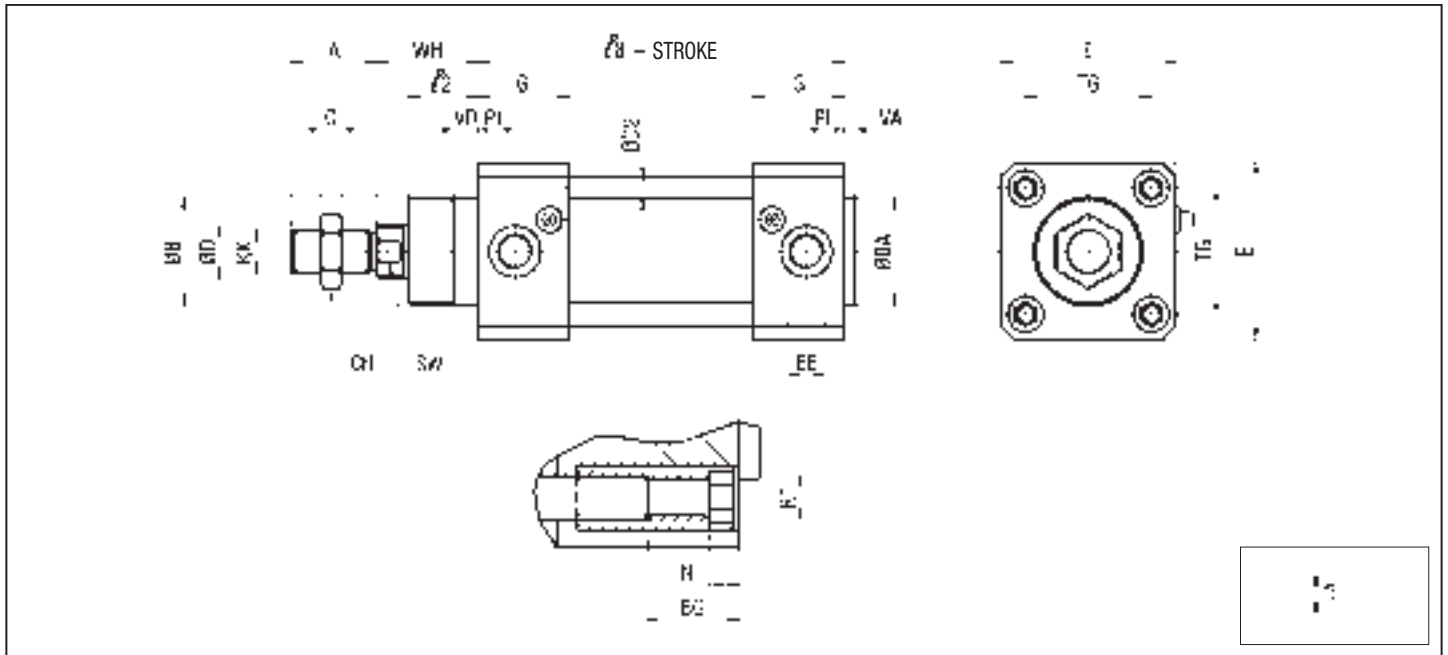

P.S.: Rod nut supplied as standard

DIMENSIONS AND WEIGHTS BASIC CYLINDER

\emptyset	A*	BA* B*	BG*	CH	D	D2	E	EE*	G	KK*	ℓ_2^*	ℓ_8^*	N	O	PL*	RT*	SW*	TG*	VA*	WH*	WEIGHT (g)	INCR. (g) every 10 mm
32	22	30	16,5	17	12	6	50	G1/8	30	M10x1,25	18	94	5	6	13	M6	10	32,5	4	26	1330	24
40	24	35	16,5	19	16	6	55	G1/4	33	M12x1,25	22	105	5	7	14	M6	13	38	4	30	1800	32
50	32	40	17,5	24	20	8	65	G1/4	33,8	M16x1,5	25,5	106	5	8	14	M8	17	46,5	4	37	2760	55
63	32	45	17,5	30	20	8	75	G3/8	38	M16x1,5	25	121	5	8	16	M8	17	56,6	4	37	7110	59
80	40	45	17,5	30	25	10	95	G3/8	39,8	M20x1,5	35	128	-	9	17	M10	22	72	4	46	7700	108
100	40	55	17,5	30	25	10	110	G1/2	43,5	M20x1,5	38	138	-	9	18	M10	22	89	4	51	11320	139
125	54	60	20,5	41	32	12	140	G1/2	52,5	M27x2	46	160	-	12	18	M12	27	110	6	65	21831	207
160	72	65	22,5	55	40	16	180	G3/4	45	M36x2	50	179,5	-	14	22,5	M16	36	140	6	80	28023	323
200	72	75	22,5	55	40	16	220	G3/4	45	M36x2	55	180	-	14	22,5	M16	36	175	6	95	40469	466

* STANDARDIZED DIMENSIONS

THROUGH ROD

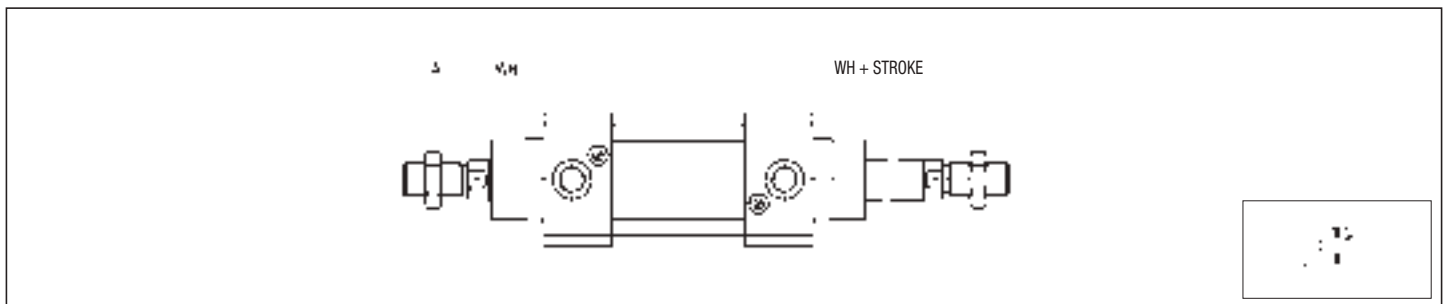

P.S.: Rod nut supplied as standard

1

FLANGE - STAINLESS STEEL - AX/F Ø (Supplied with screws)

Ø	D H11	FB H13	E	MF JS14	R JS14	TF JS14	UF
32	30	7	45	10	32	64	80
40	35	9	52	10	36	72	90
50	40	9	65	12	45	90	110
63	45	9	75	12	50	100	120
80	45	12	95	16	63	126	150
100	55	14	115	16	75	150	170

Ø	W	ZF	WEIGHT (g)
32	16	130	190
40	20	145	246
50	25	155	478
63	25	170	622
80	30	190	1430
100	35	205	1986

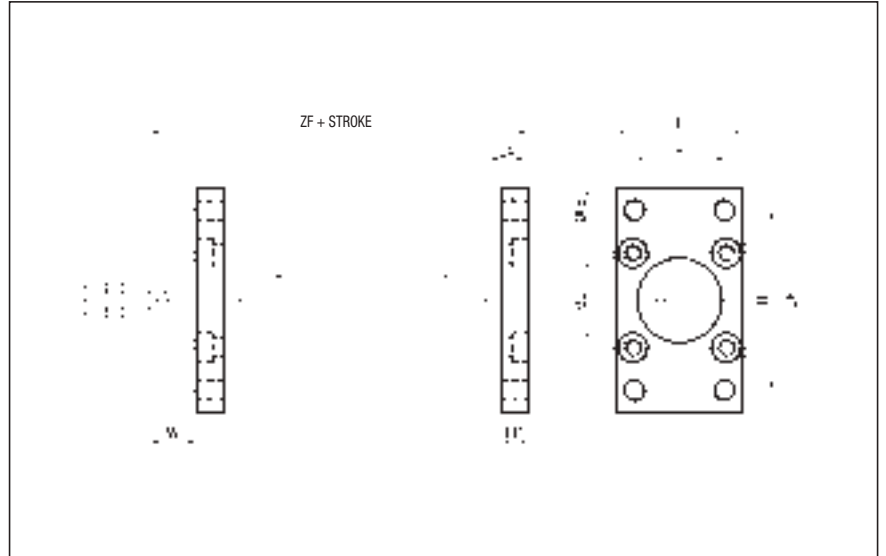

FOOT - STAINLESS STEEL - AX/PB Ø (Supplied with screws)

Ø	AB H14	AH JS15	AT	AU	E	F	SA
32	7	32	4	24	45	35	142
40	9	36	4	28	52	36	161
50	9	45	5	32	65	47	170
63	9	50	5	32	75	45	185
80	12	63	6	41	95	55	210
100	14	71	6	41	115	57	220

Ø	TR JS14	XA	WEIGHT (g)
32	32	144	66
40	36	163	78
50	45	175	168
63	50	190	190
80	63	215	382
100	75	230	452

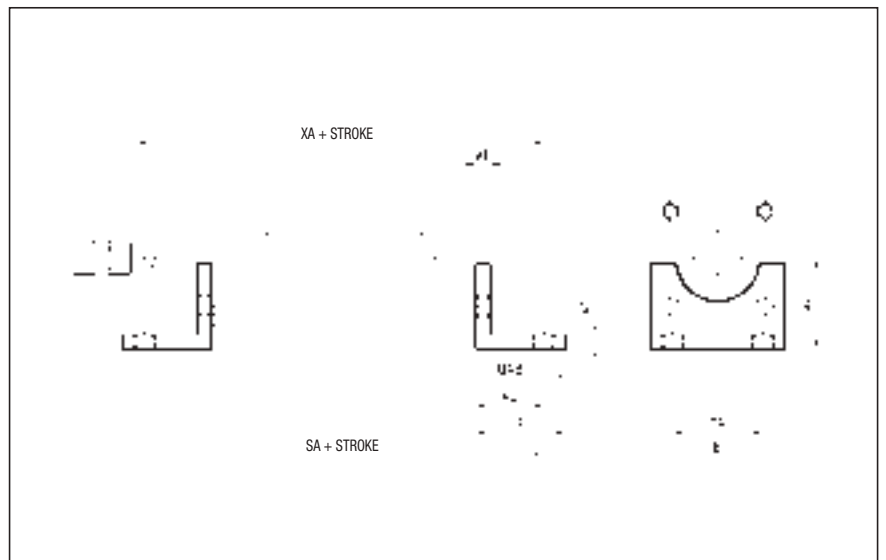

Accessories
**Stainless steel fixings for
 cylinders to ISO 15552 standard**

series **AX**

1

REAR FEMALE HINGE - STAINLESS STEEL - AX/CF Ø (Supplied with screws)

Ø	CB H14	CD H9	E	FL	L	L4	UB h14
32	26	10	45	22	13	5,5	45
40	28	12	52	25	16	5,5	52
50	32	12	65	27	16	6,5	60
63	40	16	75	32	21	6,5	70
80	50	16	95	36	22	10	90
100	60	20	115	41	27	10	110
125	70	25	140	50	30	10	130

Ø	XD	WEIGHT (g)
32	142	138
40	160	230
50	170	338
63	190	540
80	210	1000
100	230	1700
125	275	3350

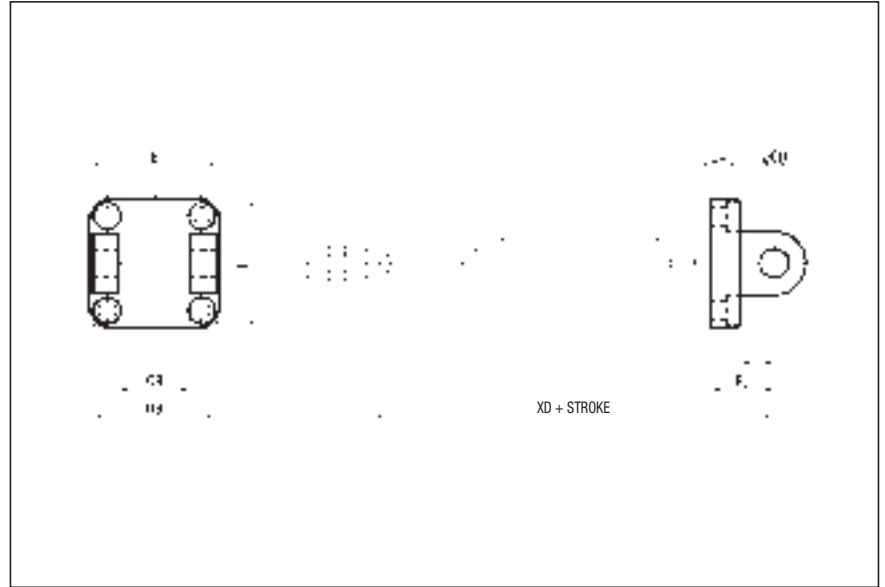

PIVOT FOR REAR FEMALE HINGE - STAINLESS STEEL - AX/SEC Ø

Ø	BU	EK f7	EL	WEIGHT (g)
32	53	10	46	32
40	60	12	53	52
50	68	12	61	60
63	78	16	71	122
80	98	16	91	152
100	118	20	111	290
125	139	25	132	530

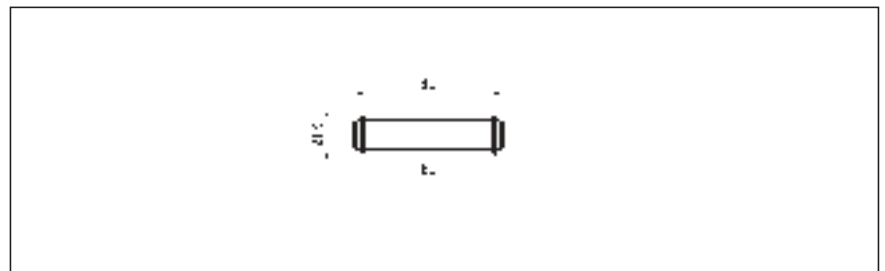

REAR MALE HINGE - STAINLESS STEEL - AX/CM Ø

Ø	CD H9	E	EW	FL	L	L4	XD
32	10	45	26	22	13	5,5	142
40	12	52	28	25	16	5,5	160
50	12	65	32	27	16	6,5	170
63	16	75	40	32	21	6,5	190
80	16	95	50	36	22	10	210
100	20	115	60	41	27	10	230
125	25	140	70	50	30	10	275

Ø	WEIGHT ALL. (g)
32	138
40	230
50	338
63	540
80	1000
100	1700
125	3350

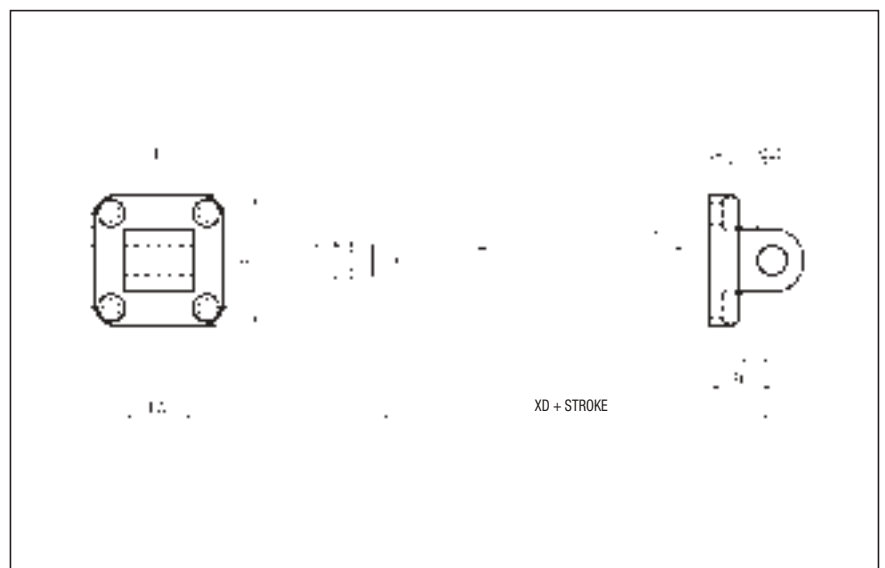

1

SQUARE JOINT - STAINLESS STEEL - AX/AS Ø

Ø	PH JS15	CK H9	EM	GL JS14	RA JS14	UR	BT	L5
32	32	10	26	21	18	31	8	1,6
40	36	12	28	24	22	35	10	1,6
50	45	12	32	33	30	45	12	1,6
63	50	16	40	37	35	50	14	1,6
80	63	16	50	47	40	60	14	2,5
100	71	20	60	55	50	70	17	2,5
125	90	25	70	70	60	90	20	3,2

Ø	BR	S5 H13	K1 JS14	K2	XD	WEIGHT (g)
32	10	6,6	38	51	142	158
40	11	6,6	41	54	160	238
50	13	9	50	65	170	418
63	15	9	52	67	190	526
80	15	11	66	86	210	1055
100	19	11	76	96	230	1360
125	22,5	14	94	124	275	3150



NARROW REAR FEMALE HINGE - STAINLESS STEEL - AX/CFS Ø (Supplied with screws)

Ø	CG D10	CP d12	B3	ØCF F7	E	FM	L10	L11
32	14	34	3,3	10	45	22	9	16,5
40	16	40	4,3	12	52	25	9	18
50	21	45	4,3	16	65	27	11	22
63	21	51	4,3	16	75	32	11	22
80	25	65	4,3	20	95	36	14	26
100	25	75	6,3	20	115	41	14	26
125	37	97	6,3	30	140	50	20	39

Ø	L4	XD	WEIGHT (g)
32	5,5	142	140
40	5,5	160	230
50	6,5	170	336
63	6,5	190	546
80	10	210	1190
100	10	230	1840
125	10	275	3550

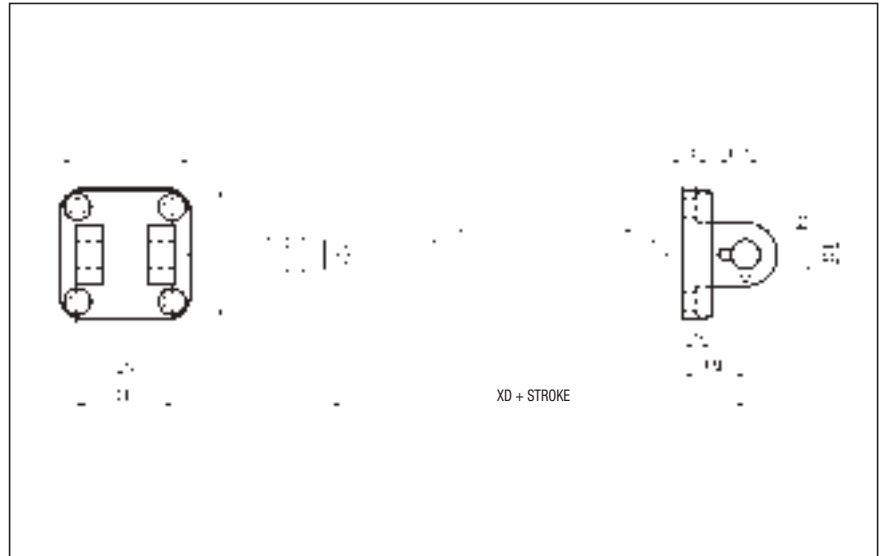

NON-ROTATING PIVOT FOR NARROW REAR FEMALE HINGE - STAINLESS STEEL - AX/SEC Ø AT

Ø	d4 H12	ØJK f7	L8	ES	L9	L5	G	WEIGHT (g)
32	3	10	14	32,5	4,5	41	4	26
40	4	12	16	38	6	48	4	42
50	4	16	20	43	6	54	5	84
63	4	16	20	49	6	60	5	94
80	4	20	24	63	6	75	6	184
100	4	20	34	73	6	85	6	208
125	6	30	36	94	9	110	7	606

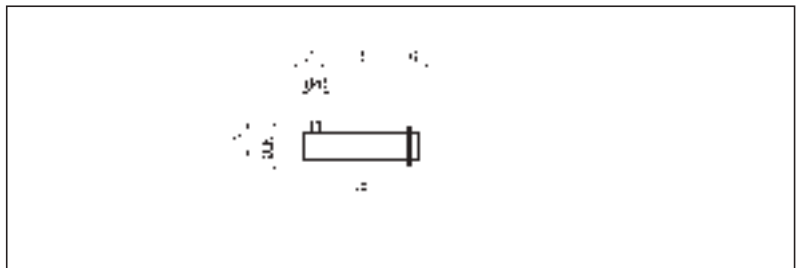

Accessories
**Stainless steel fixings for
 cylinders to ISO 15552 standard**

series **AX**

1

NARROW MALE HINGE WITH ARTICULATED HEAD (ISO 12240) - STAINLESS STEEL - AX/CMSS Ø
 (Supplied with screws)

Ø	ØCX H7	E	EN	MS	EU	G	DL
32	10	45	14	16	10,5	9	22
40	12	52	16	19	12	9	25
50	16	65	21	21	15	11	27
63	16	75	21	24	15	11	32
80	20	95	25	28,5	18	14	36
100	20	115	25	30	18	14	41
125	30	140	37	40	25	20	50

Ø	L4	XD	WEIGHT (g)
32	5,5	142	158
40	5,5	160	254
50	6,5	170	360
63	6,5	190	588
80	10	210	1118
100	10	230	1810
125	10	275	3500

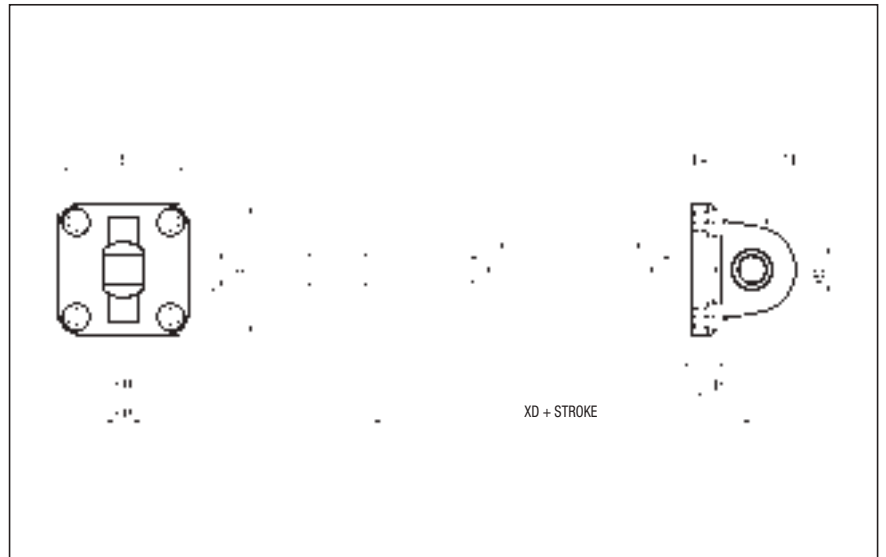

SQAURE JOINT WITH ARTICULATED HEAD (ISO 12240) - STEEL - AX/ASSS Ø

Ø	CA JS15	BQ	CK H7	EM	G1 JS14	G2 JS14	G3	H6
32	32	10,5	10	14	21	18	31	10
40	36	12	12	16	24	22	35	10
50	45	15	16	21	33	30	45	12
63	50	15	16	21	37	35	50	12
80	63	18	20	25	47	40	60	14
100	71	18	20	25	55	50	70	15
125	90	25	30	37	70	60	90	20

Ø	K1 JS14	K2	L5	R	S5 H13	XD	WEIGHT (g)
32	38	51	1,6	15	6,6	142	178
40	41	54	1,6	18	6,6	160	268
50	50	65	1,6	20	9	170	458
63	52	67	1,6	23	9	190	550
80	66	86	2,5	27	11	210	970
100	76	96	2,5	30	11	230	1326
125	94	124	3,2	40	13,5	275	3000

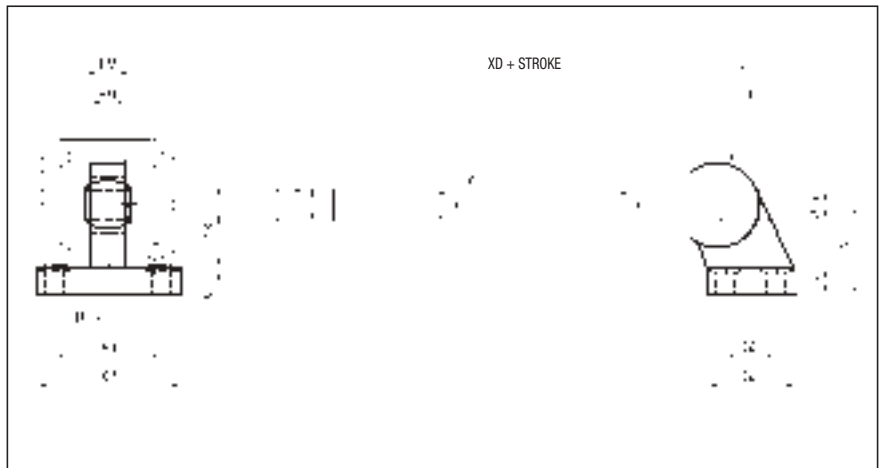

INTERMEDIATE HINGE - STAINLESS STEEL - AX/CTA Ø (Supplied with dowels)

Ø	TK e9	TD h14	TL h14	TM	UW	XV min	XV max	WEIGHT (g)
32	15	12	12	50	46	63,5	82,5	110
40	20	16	16	63	59	73	92	290
50	20	16	16	75	69	80,8	99,2	330
63	25	20	20	90	84	87,5	107,5	650
80	25	20	20	110	102	98,3	121,7	830
100	30	25	25	132	125	109,5	130,5	1560

P.S.:
 - ADJUSTABLE POSITION
 (Fixings with dowels)

ASSEMBLY:
 AX/CTA Ø + cylinder series AX + M/AX/CTA Ø

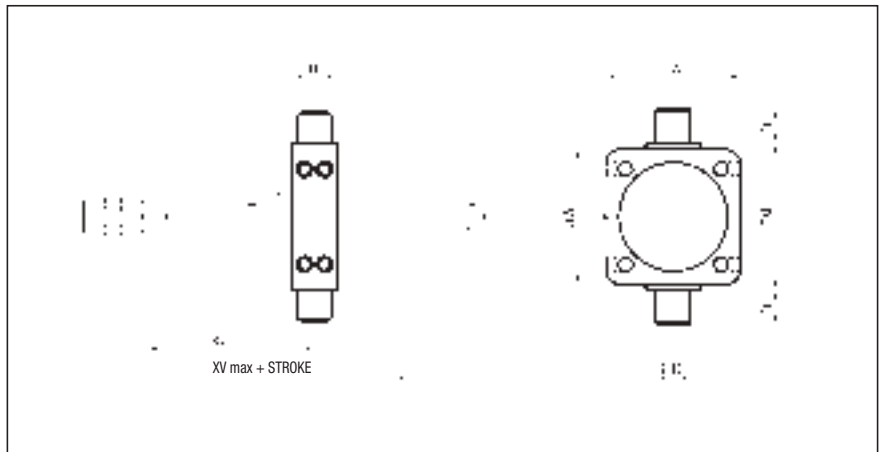

Cylinders to AFNOR NF E49-001 (ex CNOMO) standard

series CX-CXL

DESCRIPTION

Cylinders series "CX" from Ø 32 ÷ 100 and series CXL from Ø 125 ÷ 200 comply with AFNOR NF E49-001 (ex CNOMO) standard and so they result interchangeable. Cylinders series "CX" with magnetic piston type can be supplied with magnetic sensors.



TECHNICAL DATA

Operating pressure	1 ÷ 10 bar
Working temperature	0 ÷ +80 °C (-20 °C with dry air) 0 ÷ +150 °C with seals for high temperatures (-20 °C with dry air)
Fluid	Filtered, unlubricated, continuous lubricated or dry compressed air
Versions	Double acting, Single acting front spring, Single acting rear spring, Through rod, Double push tandem, Double stroke tandem, Opposed tandem
Bore	Ø 32, 40, 50, 63, 80, 100, 125, 160, 200
Port size	Ø 32 = G 1/8 Ø 40 - 50 = G 1/4 Ø 63 - 80 = G 3/8 Ø 100 - 125 = G 1/2 Ø 160 - 200 = G 3/4
Standard strokes (mm)*	25, 50, 75, 100, 125, 150, 200, 250, 300, 350, 400, 500, 600, 700, 800, 900, 1000
Decelerators length	Ø 32 40 50 63 80 100 125 160 200 mm 25 30 30 35 35 40 40 50 50
Maximum strokes (mm)	Ø 32 ÷ 200 = 3000; version T, P, V = 1000
Max. strokes single acting (mm)	Ø 32 ÷ 100 = 50

Cylinders, with strokes shorter than the decelerators lengths, are NOT cushioned as standard.

ORDER KEY

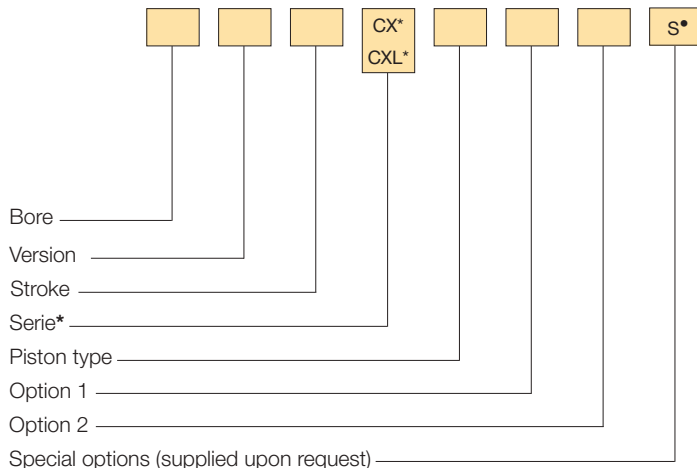

* Series CX from Ø 32 ÷ 100; series CXL from Ø 125 ÷ 200.

• See Chapter 1, page 1.1.

ORDER EXAMPLES

Cylinder Ø 50, double acting, 100 mm stroke, non-magnetic piston type: **50/100 CX**

Cylinder Ø 160, through rod, 150 mm stroke, magnetic piston type, stainless steel piston rod: **160R150 CXL/FM1**

Cylinder Ø 80, double push tandem, 50 mm stroke, magnetic piston type: **80T50 CX/FM**

Cylinder Ø 80, double stroke tandem, 50 mm stroke 1 + 100 mm stroke 2, magnetic piston type: **80P50+100 CX/FM**

Cylinder Ø 80, opposed tandem, 50 mm stroke 1 + 50 mm stroke 2, magnetic piston type, brass cylinder barrel: **80V50+50 CX/FM4**

MATERIALS

End caps	Anodized aluminium alloy
Cylinder barrel	Extruded tube, anodized aluminium alloy
Tie rods, tie and rod nuts	Steel Stainless steel (supplied upon request for tie rods and tie nuts)
Piston rod	C45 chromium-plated steel AISI 303 rolled stainless steel
Piston rod bearing	Bronze-iron 20%, sintered, self-lubricating
Decelerators ogives	Aluminium alloy
Piston	NBR rubber block (supplied with and without magnet) FKM (Viton®) supplied only with non-magnetic piston type
Seals	NBR rubber FKM (Viton®)
Spring	Springs steel

VERSION

/	Double acting	T	Double push tandem
S	Single acting front spring	P	Double stroke tandem
Y	Single acting rear spring	V	Opposed tandem
R	Through rod		

PISTON TYPE

Non-magnetic /FM Magnetic*

OPTION 1

1	Stainless steel piston rod and rod nut	3	Stainless steel piston rod and rod nut and seals for high temperatures
2	Seals for high temperatures		

OPTION 2

4	Brass cylinder barrel**	6	Inner chromium-plated steel cylinder barrel**
---	-------------------------	---	---

* Available even with "FKM" (Viton®) seals but just for applications where is needed a chemical compatibility; not available for high temperatures
** Supplied from Ø 50 ÷ 100

SPARE PARTS

SEALS KIT		
Non-magnetic piston type	NBR Ø 32 ÷ 100	Ø/SG/CX
	NBR Ø 125 ÷ 200	Ø/SG/CXL
	Through rod NBR Ø 32 ÷ 100	Ø/SG/R/CX
	Through rod NBR Ø 125 ÷ 200	Ø/SG/R/CXL
	For high temperature Ø 32 ÷ 100	Ø/SG/CX2
	For high temperature Ø 125 ÷ 200	Ø/SG/CXL2
Magnetic piston type	Through rod for high temperature Ø 32 ÷ 100	Ø/SG/R/CX2
	Through rod for high temperature Ø 125 ÷ 200	Ø/SG/R/CXL2
	NBR Ø 32 ÷ 100	Ø/SG/CX/FM
	NBR Ø 125 ÷ 200	Ø/SG/CXL/FM
	Through rod NBR Ø 32 ÷ 100	Ø/SG/R/CX/FM
	Through rod NBR Ø 125 ÷ 200	Ø/SG/R/CXL/FM

series CX-CXL

Cylinders
to AFNOR NF E49-001
(ex CNOMO) standard

CX - CXL BASIC CYLINDER

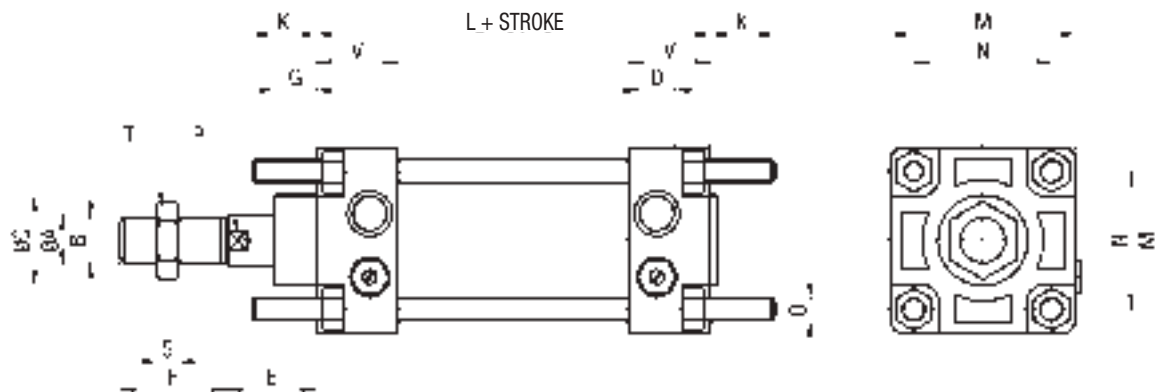

P.S.: Rod nut supplied as standard

DIMENSIONS AND WEIGHTS BASIC CYLINDER

Ø	A	B	C	D	E	F	G	H	K	L*	M	N	O	P	R	S	T	V	WEIGHT (g)	INCREMENT (g) every 10 mm
32	12	M10	25	M6	25	20	15	134	17	86	45	33	G 1/8	10	7	5	17	26	482	23
40	18	M16x1,5	32	M6	34	36	15	191	17	110	52	40	G 1/4	16	7	8	24	29	907	35
50	18	M16x1,5	32	M8	34	36	15	191	23	110	65	49	G 1/4	16	7	8	24	29	1170	46
63	22	M20x1,5	45	M8	39	46	20	216	23	125	75	59	G 3/8	20	9	10	30	34	1817	59
80	22	M20x1,5	45	M10	39	46	20	215	28	125	95	75	G 3/8	20	9	10	30	35	2680	66
100	30	M27x2	55	M10	47	63	20	251	28	153	115	90	G 1/2	27	9	13,5	41	39	4422	93
125	30	M27x2	55	M12	47	63	20	248	34	145	140	110	G 1/2	27	9	13,5	41	42	6630	110
160	40	M36x2	65	M16	50	85	25	310	42	180	180	140	G 3/4	36	13	18	55	50	13820	210
200	40	M36x2	65	M16	50	85	25	310	42	180	220	175	G 3/4	36	13	18	55	50	18840	290

*Dimension "L" in the "Through rod cylinder" is NOT to standard.

THROUGH ROD

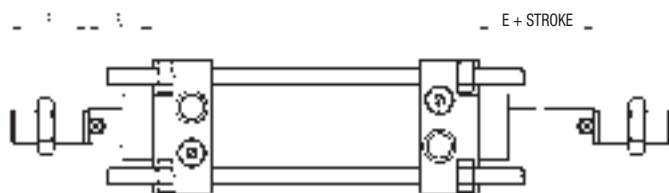

P.S.: Rod nut supplied as standard

DOUBLE PUSH TANDEM

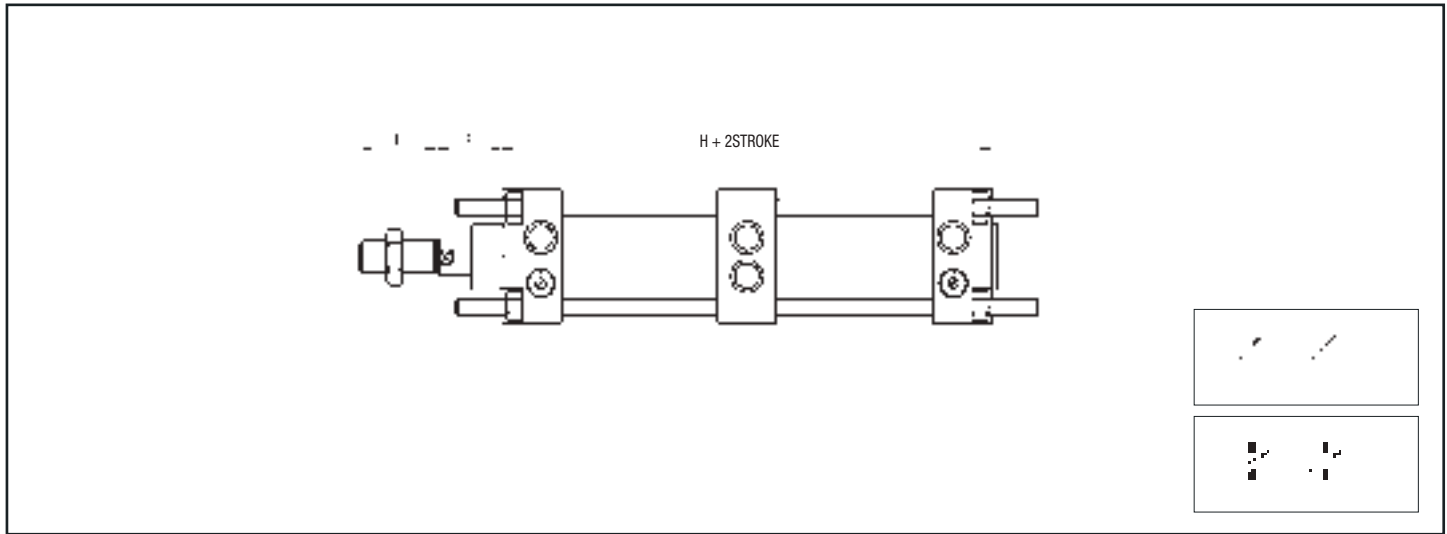

P.S.: Rod nut supplied as standard

DOUBLE STROKE TANDEM

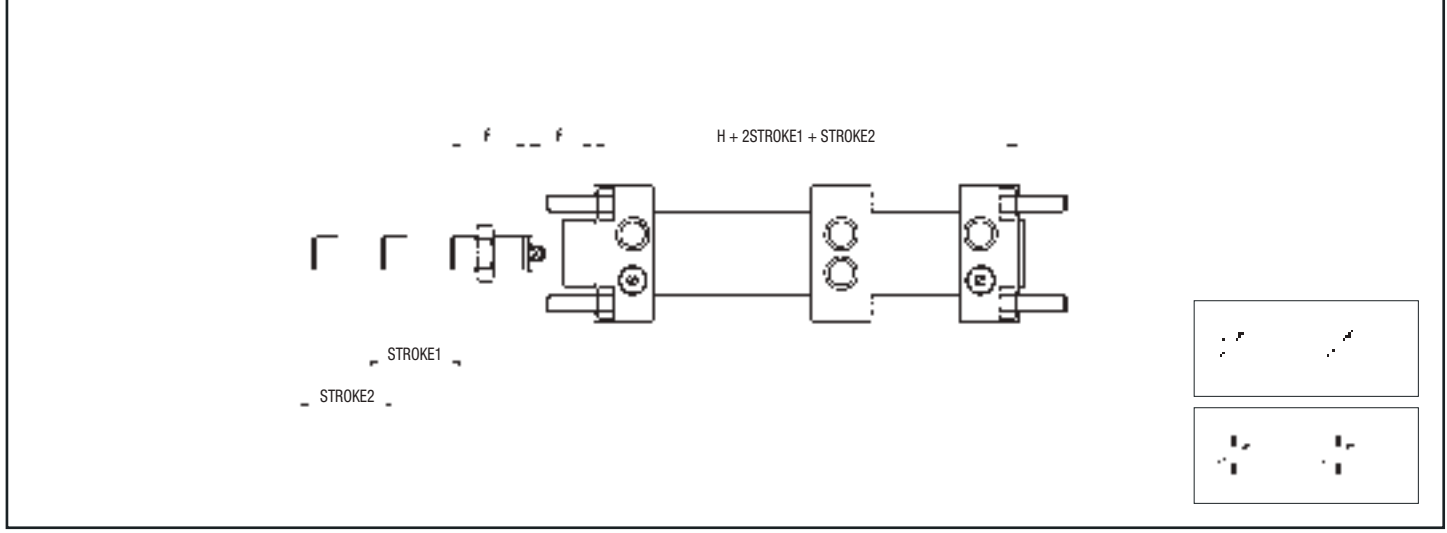

P.S.: Rod nut supplied as standard

OPPOSED TANDEM

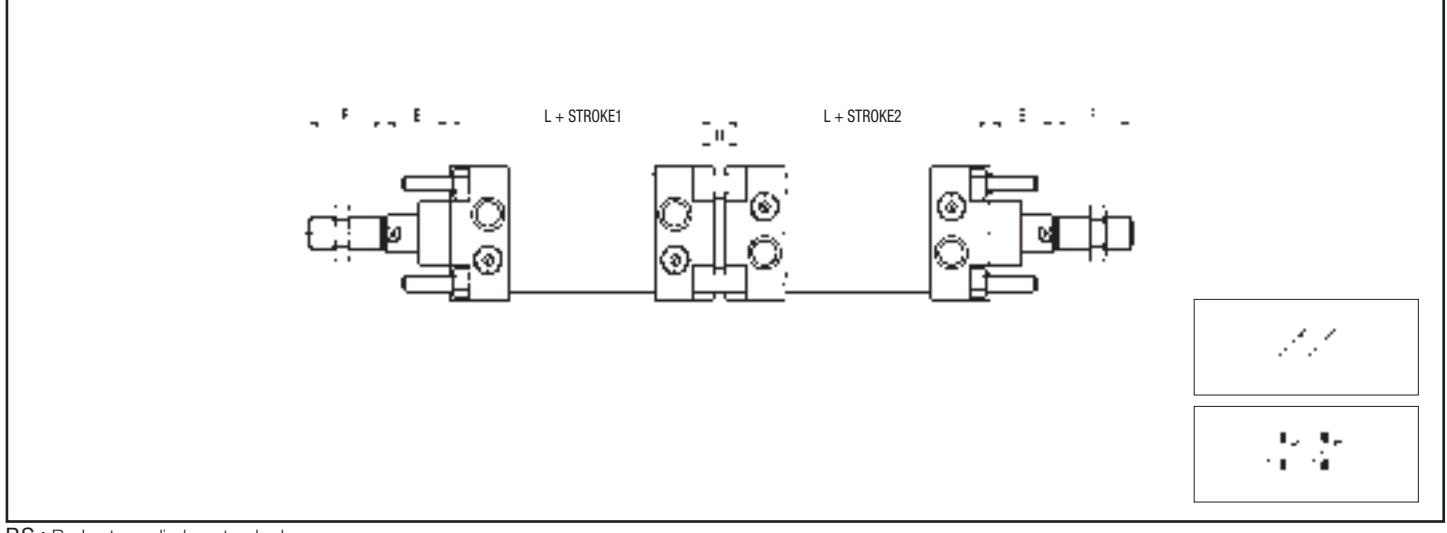

P.S.: Rod nut supplied as standard

series CX-CXL

Accessories Fixings for cylinders to AFNOR NF E49-001 (ex CNOMO) standard

1

FLANGE - STEEL - CX/F Ø

Ø	A	B	D H13	E	G	LE	LF
32	68	80	9	33	8	17	113
40	78	90	9	40	8	26	152
50	94	110	11	49	10	24	154
63	104	120	11	59	10	29	174
80	130	150	14	75	12	27	176
100	150	170	14	90	12	35	204
125	180	205	18	110	16	31	208
160	228	260	22	140	20	30	250
200	268	300	22	170	20	30	250

Ø	M	WEIGHT (g)
32	45	158
40	52	206
50	65	424
63	75	504
80	95	1046
100	115	1480
125	140	3000
160	180	6300
200	220	9300

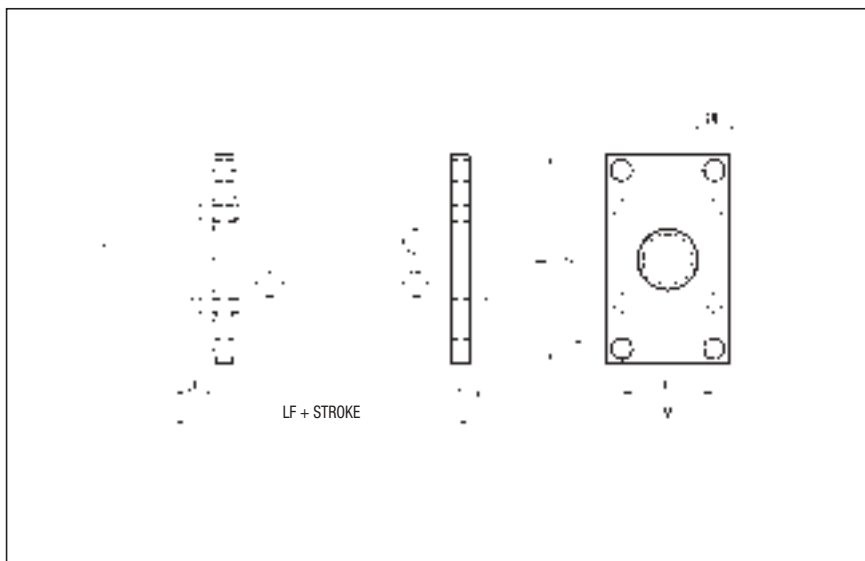

HIGH FOOT - ALUMINIUM - CX/P Ø

Ø	A	D H13	F	G	H	LA	LW
32	28	9	32	8	35	134	132
40	36	9	36	8	35	164	171
50	45	11	45	10	45	180	179
63	55	11	50	10	45	195	199
80	70	14	63	12	55	211	207
100	90	14	73	12	55	231	235
125	100	18	91	16	68	249	244
160	130	22	115	20	82	304	292
200	170	22	135	20	92	304	292

Ø	M	O	WEIGHT (g)
32	45	27	54
40	52	27	70
50	65	35	150
63	75	35	170
80	95	43	354
100	115	43	470
125	140	52	918
160	180	62	2300
200	220	62	3450

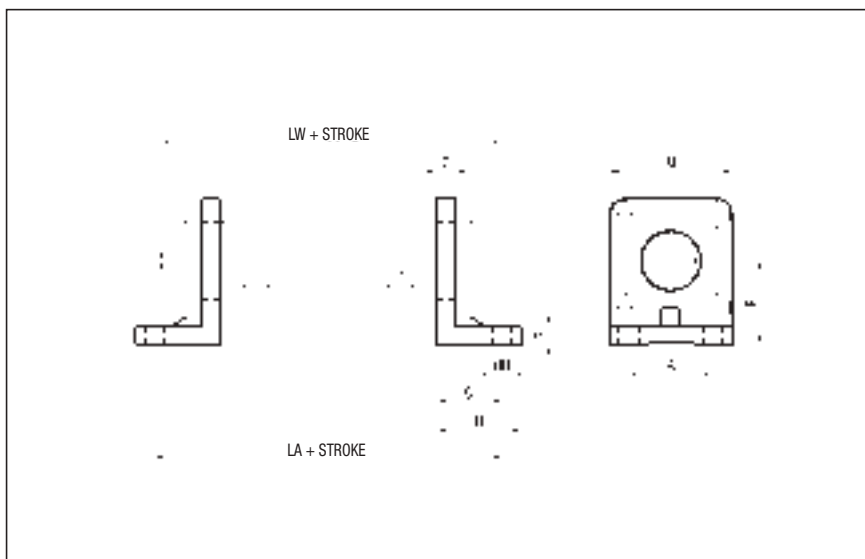

LARGE HIGH FOOT - ALUMINIUM - CX/PL Ø

Ø	A	B	D H13	F	G	H	LC
32	65	82	9	32	8	35	116
40	72	90	9	36	8	35	146
50	90	110	11	45	10	45	154
63	100	120	11	50	10	45	169
80	126	154	14	63	12	55	181
100	148	180	14	73	12	55	201
125	180	216	18	91	16	67,5	209
160	230	275	22	115	20	80	260
200	270	318	22	135	20	80	260

Ø	LD	LP	LQ	M	O	P	WEIGHT (g)
32	60	95	123	45	18	54,5	76
40	90	134	162	52	18	62	90
50	86	132	166	65	22	77,5	188
63	101	152	186	75	22	87,5	206
80	93	148	192	95	28	110	410
100	113	176	220	115	28	130	576
125	113	176	224	140	32	161	1058
160	140	210	270	180	40	206	2350
200	140	210	270	220	40	246	3100

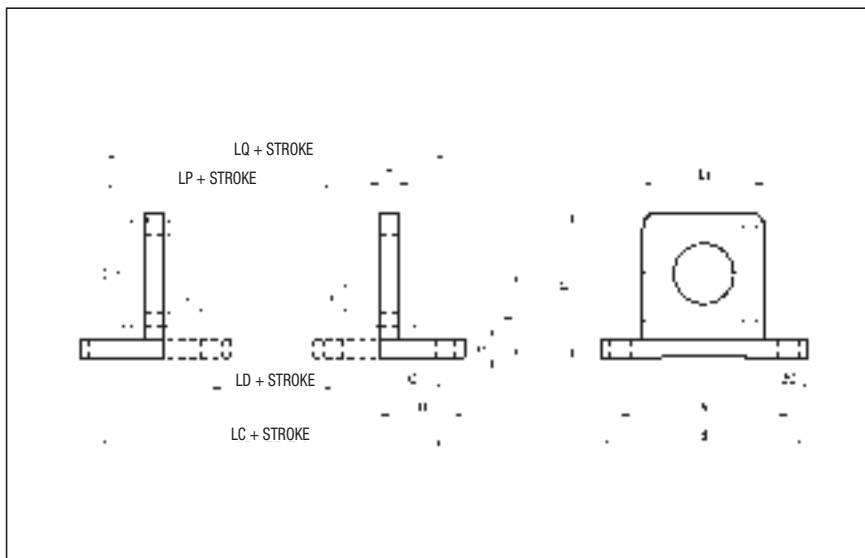

LOW FOOT - STEEL - CX/PB Ø

Ø	A	D	E	F	H	LA	LW
32	28	45	15,5	32	35	134	132
40	36	52	16	36	36	164	171
50	45	65	20,5	45	45	180	179
63	55	75	20,5	50	45	195	199
80	70	95	25,5	63	55	211	207
100	90	115	27	73	56	231	235
125	100	140	36	91	70	249	244
160	130	180	45	115	75	304	292
200	170	220	47	135	100	304	292

Ø	M H13	O	S	WEIGHT (g)
32	4,5	27	4	66
40	4,5	27	4	78
50	5,5	35	5	168
63	5,5	35	5	190
80	7	43	6	382
100	7	43	6	452
125	9	52	8	1090
160	11	62	10	1180
200	11	62	12	3450

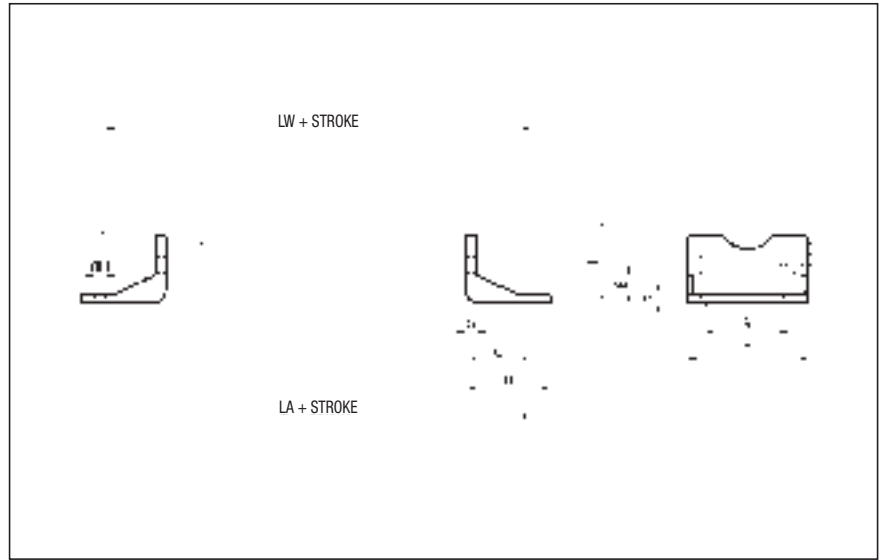

FEMALE HINGE - ALUMINIUM - CX/CF Ø

Ø	G	K	LY	M	O	R	S H9
32	8	18	123	45	26	8	8
40	8	24	168	52	33	12	12
50	10	26	170	65	33	12	12
63	10	30	194	75	47	16	16
80	12	32	196	95	47	16	16
100	12	37	229	115	57	20	20
125	16	41	233	140	57	21	20
160	20	55	285	180	72	25	25
200	20	55	285	220	72	25	25

Ø	WEIGHT (g)
32	38
40	58
50	118
63	146
80	324
100	492
125	978
160	1872
200	2800

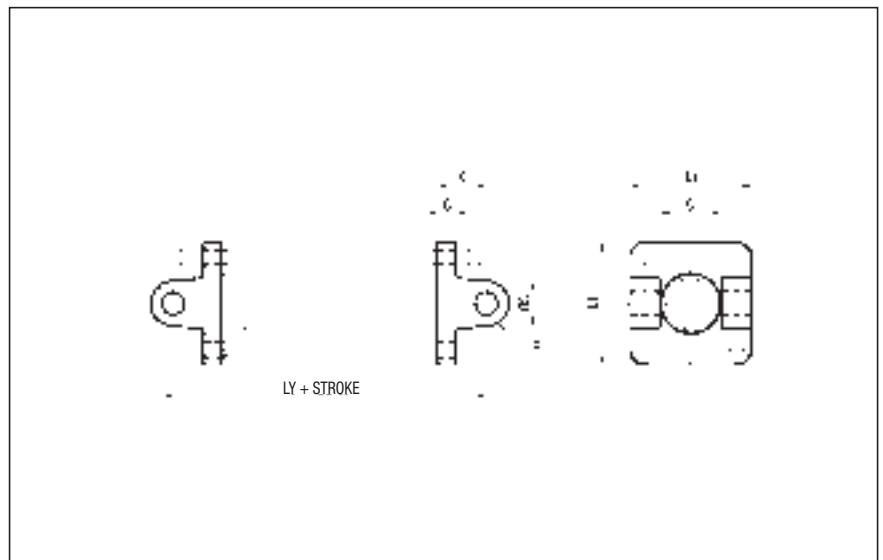

PIVOT FOR REAR FEMALE HINGE - ZINC-PLATED STEEL - CX/SEC Ø

Ø	EK f7	EL	BU	WEIGHT (g)
32	8	46	53	21
40	12	53	60	52
50	12	66	73	64
63	16	76	83	130
80	16	96	103	160
100	20	117	124	304
125	20	142	149	364
160	25	182	189	720
200	25	222	229	872

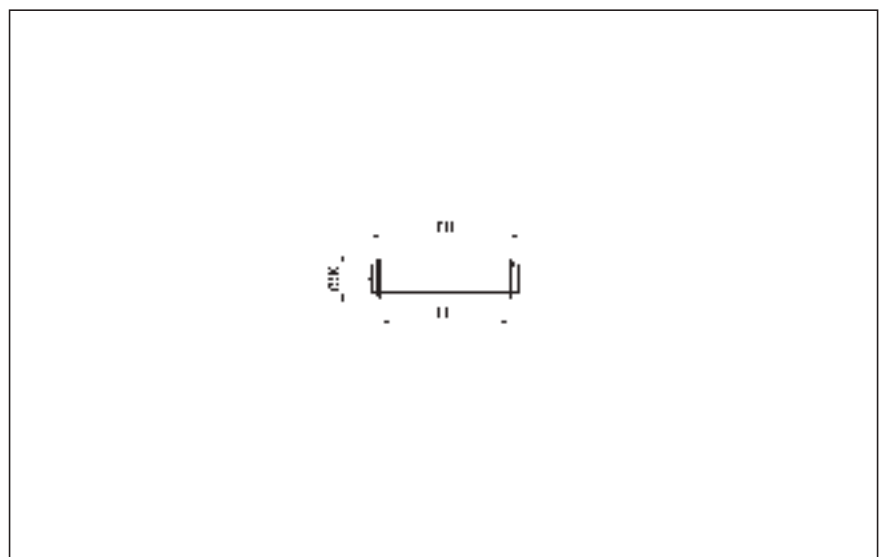

series CX-CXL

Accessories Fixings for cylinders to AFNOR NF E49-001 (ex CNOMO) standard

1

NORMAL ARTICULATED JOINT - ALUMINIUM - CX/AN Ø

Ø	A	B	D	E	F	H	LY
32	25	0	40	28	7	26	123
40	32	16	52	38	9	38	168
50	32	16	52	38	9	38	170
63	46	25	75	54	11	52	194
80	46	25	75	54	11	52	196
100	56	32	115	90	14	61	229
125	56	32	115	90	14	61	233
160	71	43	180	150	18	80	285
200	71	43	180	150	18	80	285

Ø	P	S H9	T	WEIGHT (g)
32	18	8	8	26
40	26	12	10	56
50	26	12	10	56
63	34	16	12	176
80	34	16	12	176
100	41	20	16	376
125	41	20	16	376
160	55	25	20	924
200	55	25	20	924

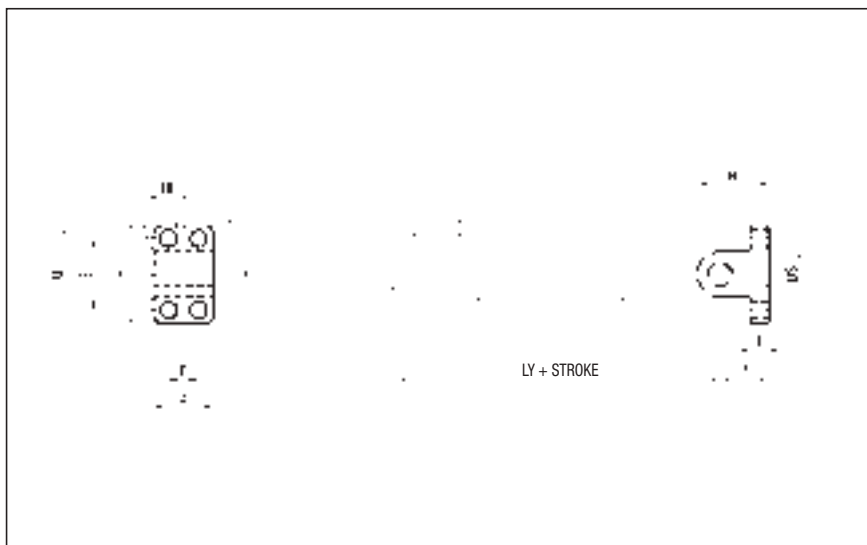

SQUARE JOINT - ALUMINIUM- CX/AS Ø/SQ

Ø	A	B	BG	D	F H13	H	LY
32	25	25	20	37	7	18	123
40	32	32	32	54	9	25	168
50	32	32	32	54	9	25	170
63	46	40	50	75	11	32	194
80	46	40	50	75	11	32	196
100	56	50	70	103	14	40	229
125	56	50	70	103	14	40	233
160	70	63	110	154	18	50	285
200	70	63	110	154	18	50	285

Ø	P	R	S H9	T	V	WEIGHT (g)
32	32	19,5	8	8	41	58
40	45	26	12	10	52	144
50	45	26	12	10	52	144
63	63	32	16	13	63	300
80	63	32	16	13	63	300
100	90	42	20	17	80	649
125	90	42	20	17	80	649
160	140	54	25	20	111	1922
200	140	54	25	20	111	1922

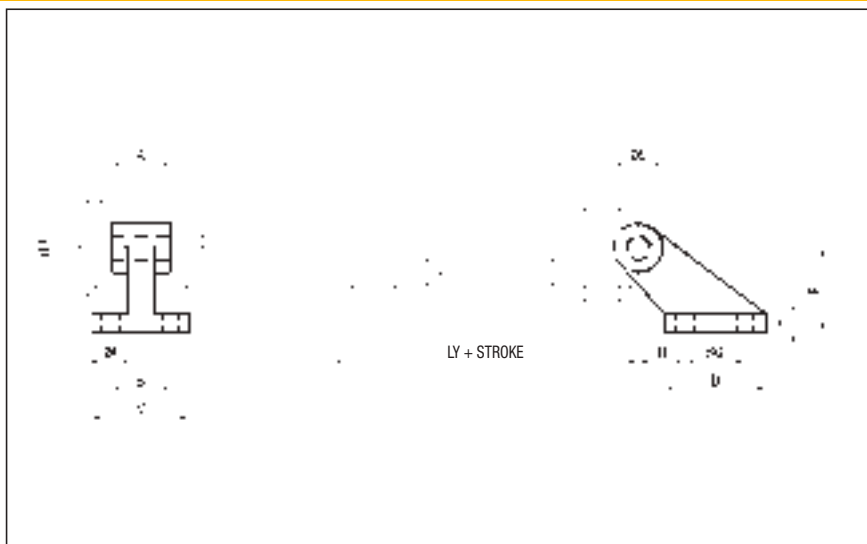

INTERMEDIATE HINGE (Supplied with dowels)

- STEEL - CX/CPU/CT - Ø 32 ÷ 100
- STEEL - CX/CPU/CT - Ø 125 ÷ 200

Ø	A	B h14	D e9	E h14	G	M	Q min
32	46	50	12	12	15	6,25	58,5
40	59	63	16	16	20	6,25	73
50	69	73	16	16	20	8,25	73
63	84	90	20	20	25	8,25	85,5
80	102	108	20	20	25	10,25	86,5
100	125	131	25	25	30	10,25	101
125	155	160	25	25	32	12,25	105
160	190	200	32	32	40	16,25	120
200	240	250	32	32	40	16,25	120

Ø	Q max	WEIGHT (g)
32	71,5	110
40	105	290
50	105	330
63	117,5	650
80	116,5	830
100	138	1560
125	134	2450
160	160	4150
200	160	7300

PS.: - ADJUSTABLE POSITION
(fixing through dowels)

ASSEMBLY:
CX/CPU/CT Ø + cylinder CX type M/CX/CPU/CT Ø
- FIXED POSITION
(specify dimension "Q"; fixed on cylinder with
completed threaded and galvanized tie rods type "S6")
Ø32 ÷ 63 require stainless steel tube.
Please contact our sales offices.

ASSEMBLY:
CX/CPU/CT Ø or CX/CPU/CT Ø
+ cylinder CX S6 type MF/CX/CPU/CT Ø

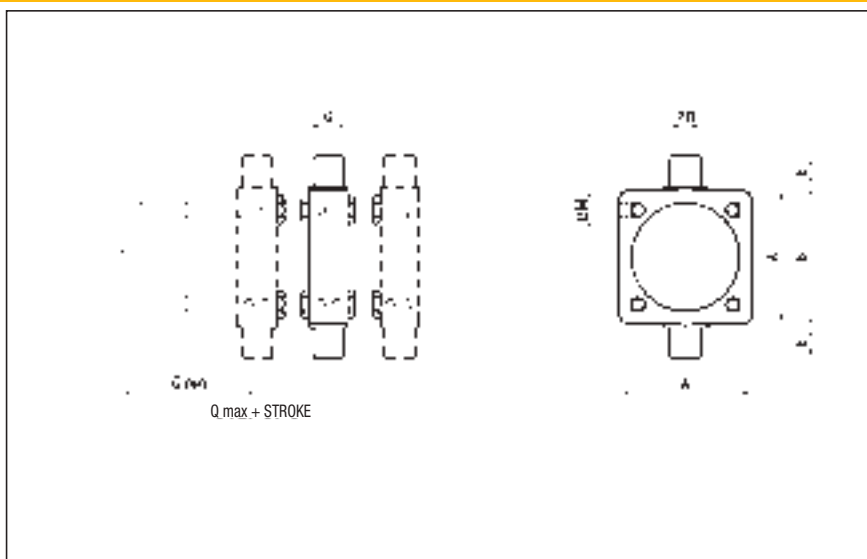

Cylinders to ex CETOP RP 43 P standard

series CPU

DESCRIPTION

Cylinders series "CPU" comply with ex CETOP RP 43 P standard. The versions with magnetic piston type can be supplied with magnetic sensors.

TECHNICAL DATA

Operating pressure	1 ÷ 10 bar
Working temperature	0 ÷ +80 °C (-20 °C with dry air) 0 ÷ +150 °C with seals for high temperatures (-10 °C with dry air)
Fluid	Filtered, unlubricated, continuous lubricated or dry compressed air
Versioni	Double acting, Single acting front spring, Single acting rear spring, Through rod
Bore	Ø 32, 40, 50, 63, 80, 100
Port size	Ø 32 = G 1/8 Ø 40 - 50 = G 1/4 Ø 63 - 80 = G 3/8 Ø 100 = G 1/2
Standard strokes (mm)*	25, 50, 75, 100, 125, 150, 200, 250, 300, 350, 400, 500, 600, 700, 800, 900, 1000
Decelerators length	Ø 32 40 50 63 80 100 mm 25 30 30 35 35 40
Maximum strokes (mm)	Ø 32 ÷ 100 = 3000
Max. strokes single acting (mm)	Ø 32 ÷ 100 = 50

*Cylinders, with strokes shorter than the decelerators lengths, are NOT cushioned as standard.

ORDER KEY

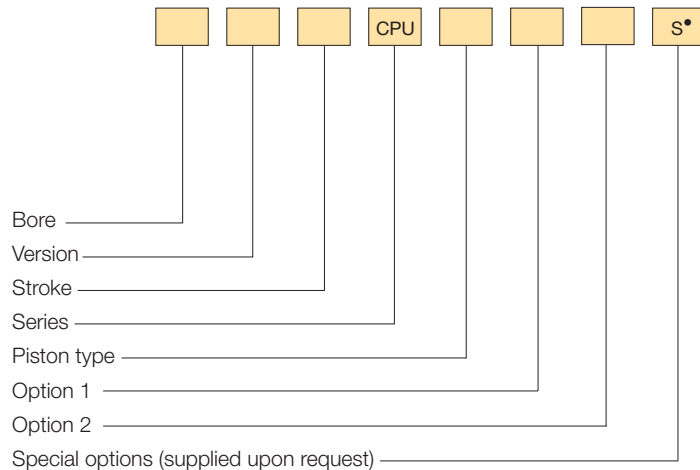

• See Chapter 1, page 1.1.

ORDER EXAMPLES

Cylinder Ø 50, double acting, 100 mm stroke, non-magnetic piston type: **50/100 CPU**

Cylinder Ø 63, through rod, 150 stroke, magnetic piston type, stainless steel piston rod: **63R150 CPU/FM1**



MATERIALS

End caps	Anodized aluminium alloy
Cylinder barrel	Extruded tube, anodized aluminium alloy
Tie rods, tie and rod nuts	Steel Stainless steel (supplied upon request for tie rods and tie nuts)
Piston rod	C45 chromium-plated steel AISI 303 rolled stainless steel
Piston rod bearing	Bronze-iron 20%, sintered, self-lubricating
Decelerators ogives	Aluminium alloy
Piston	NBR rubber block (supplied with and without magnet) FKM (Viton®) supplied only with non-magnetic piston
Seals	NBR rubber FKM (Viton®)
Spring	Spring steel

VERSION

/ Double acting	Y	Single acting rear spring
S Single acting front spring	R	Through rod

PISTON TYPE

Non-magnetic	/FM	Magnetic*
--------------	-----	-----------

OPTION 1

1 Stainless steel piston rod and rod nut	3	Stainless steel piston rod and rod nut and seals for high temperatures
2 Seals for high temperatures		

OPTION 2

4 Brass cylinder barrel**	6	Inner chromium-plated steel cylinder barrel**
---------------------------	---	---

* Available even with "FKM" (Viton®) seals but just for applications where is needed a chemical compatibility; not available for high temperatures.

**Supplied from Ø 50 ÷ 100

SPARE PARTS

SEALS KIT		
Non-magnetic piston type	NBR	Ø/SG/CPU
	Through rod NBR	Ø/SG/R/CPU
	For high temperatures	Ø/SG/CPU2
	Through rod for high temperatures	Ø/SG/R/CPU2
Magnetic piston type	NBR	Ø/SG/CPU/FM
	Through rod NBR	Ø/SG/R/CPU/FM

CPU BASIC CYLINDER

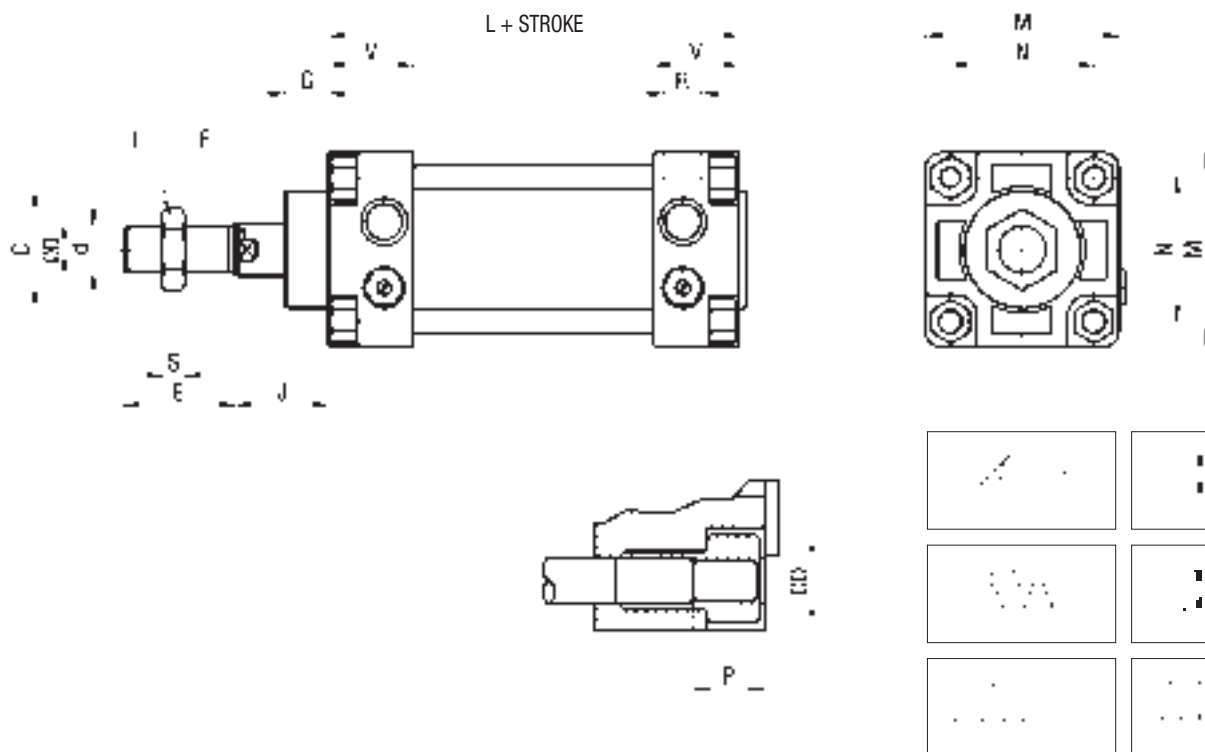

P.S.: Rod nut supplied as standard

DIMENSIONS AND WEIGHTS BASIC CYLINDER

Ø	C	d	D	DD	E	F	G	J	L	M	N	P	R	S	T	V	WEIGHT (g)	INCR. (g) x 10 mm
32	M30x1,5	M10x1,25	12	M6	20	10	15	24	98	45	33	14	G 1/8	6	17	26	517	21
40	M35x1,5	M12x1,25	18	M6	24	13	18	28	110	52	40	14	G 1/4	7	19	29	810	36
50	M40x1,5	M16x1,5	18	M8	32	16	20	35	110	65	49	15	G 1/4	8	24	29	1210	44
63	M40x1,5	M16x1,5	22	M8	32	17	20	35	125	75	59	15	G 3/8	8	24	34	1727	61
80	M45x1,5	M20x1,5	22	M10	40	20	20	42	136	95	75	16	G 3/8	9	30	35	2590	64
100	M55x2	M20x1,5	25	M10	40	22	28	47	145	115	90	16	G 1/2	9	30	39	3970	76

THROUGH ROD

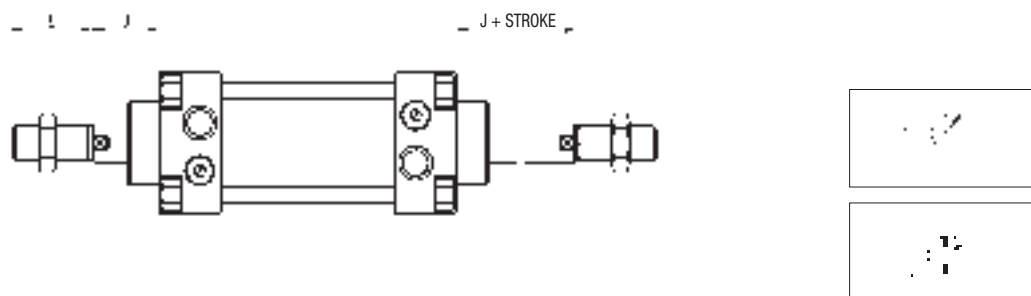

P.S.: Rod nut supplied as standard

FLANGE - STEEL - CPU/F Ø (Supplied with screws)

Ø	A	B	C	F	G	Q	M
32	32	80	45	7	8	16	130
40	36	90	52	9	8	20	146
50	45	110	65	9	10	25	155
63	50	120	75	9	10	25	170
80	63	150	95	12	12	30	190
100	75	170	115	14	12	35	204

Ø	O	WEIGHT (g)
32	64	145
40	72	195
50	90	390
63	100	530
80	126	1045
100	150	1450

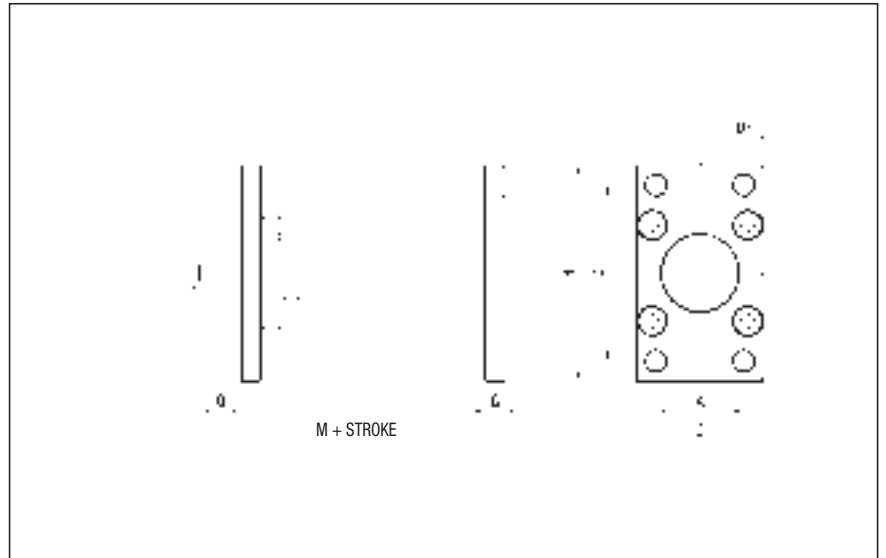

HIGH FOOT - ALUMINIUM - CPU/P Ø (Supplied with screws)

Ø	A	B	C	F	G	H	L
32	32	144	142	7	32	35	22
40	36	164	162	9	36	35	26
50	45	173	166	9	45	43	28
63	50	190	185	9	50	45	30
80	63	215	210	12	63	55	37
100	75	229	219	14	71	55	37

Ø	M	S	WEIGHT (g)
32	45	8	55
40	52	8	65
50	65	10	140
63	75	10	190
80	95	12	370
100	115	12	500

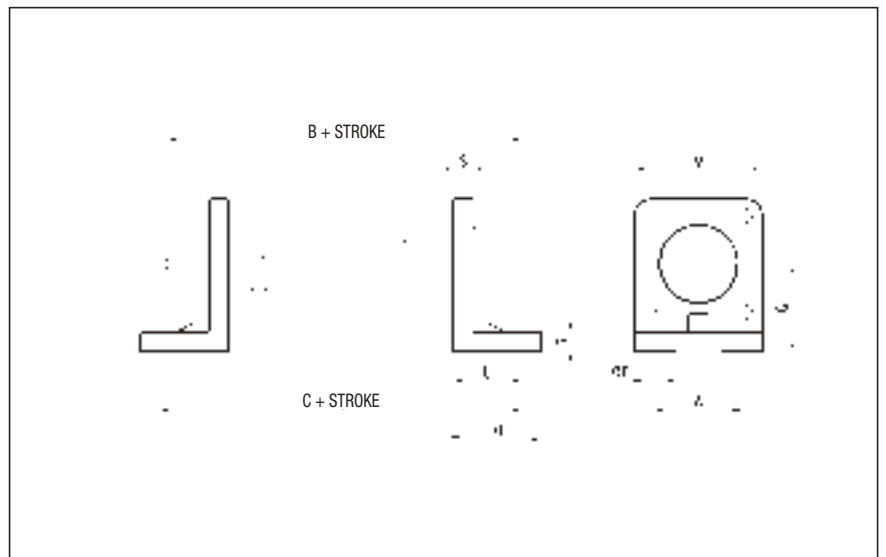

REAR FEMALE HINGE - ALUMINIUM - CPU/CF Ø (Supplied with screws)

Ø	F	I	H	J	k	L	M
32	9	12	142	10	26	45	45
40	12	15	161	12	28	52	52
50	12	17	172	12	32	60	65
63	17	20	190	16	40	70	75
80	17	20	210	16	50	90	95
100	21	25	229	20	60	110	115

Ø	X	WEIGHT (g)
32	20	35
40	23	55
50	27	105
63	30	170
80	32	300
100	37	455

PS.:
 This hinge can be used also
 with square joint of series
 "X" and "XT"(see page 1.35)

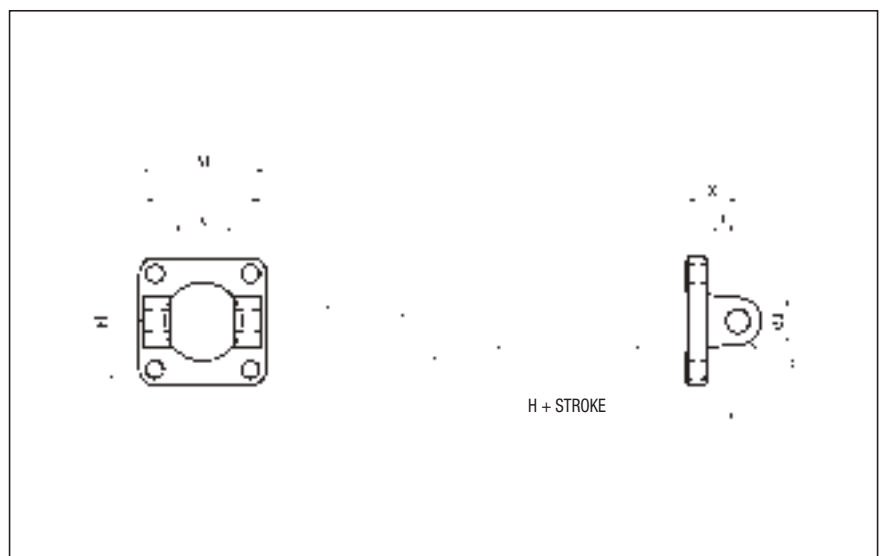

1

PIVOT FOR REAR FEMALE HINGE - ZINC-PLATED STEEL - CPU/CPUI/SEC Ø

Ø	BU	EK f7	EL	WEIGHT (g)
32	53	10	46	32
40	60	12	53	52
50	68	12	61	60
63	78	16	71	122
80	98	16	91	152
100	118	20	111	290

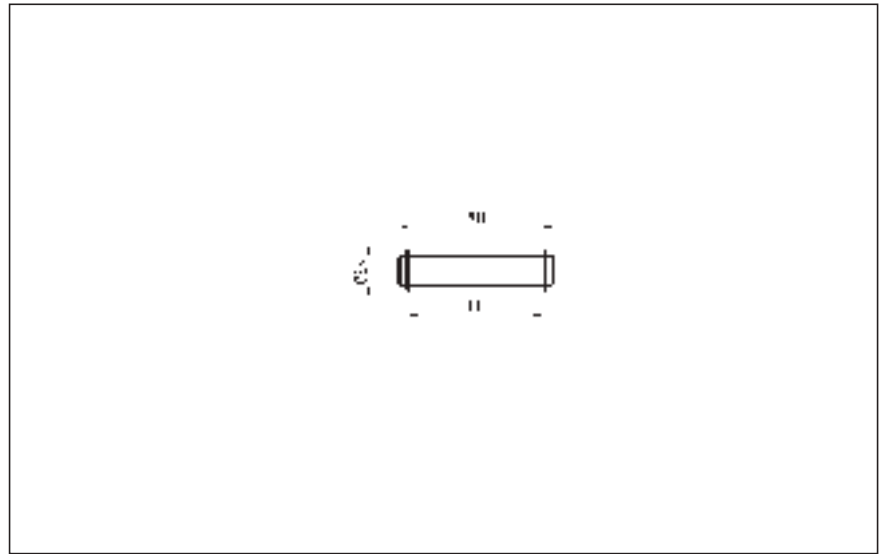

MALE HINGE - ALUMINIUM - CPU/CM Ø

Ø	F	I	H	J H9	M	O	X
32	10	12	142	10	45	26	20
40	12	15	161	12	52	28	23
50	12	17	172	12	65	32	27
63	16	20	190	16	75	40	30
80	16	20	210	16	95	50	32
100	20	25	229	20	115	60	37

Ø	WEIGHT (g)
32	50
40	70
50	140
63	210
80	350
100	565

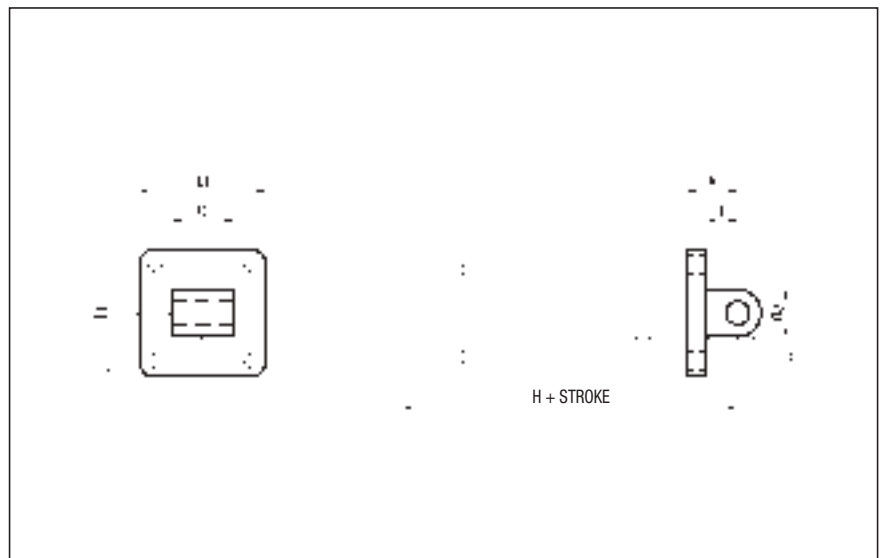

INTERMEDIATE HINGE - STEEL - CX/CPU/CT Ø (Supplied with dowels)

Ø	A	B h14	D e9	E h14	G	M	Q min
32	46	50	12	12	15	6,25	57,5
40	59	63	16	16	20	6,25	67
50	69	73	16	16	20	8,25	74
63	84	90	20	20	25	8,25	81,5
80	102	108	20	20	25	10,25	89,5
100	125	131	25	25	30	10,25	101

Ø	Q max	WEIGHT (g)
32	88,5	110
40	99	290
50	106	330
63	113,5	650
80	130,5	830
100	138	1560

P.S.:
 - ADJUSTABLE POSITION
 (fixing through dowels)

ASSEMBLY:
 CX/CPU/CT Ø + cylinder CPU type M/CX/CPU/CT Ø

- FIXED POSITION
 (specify dimension "Q"; fixed on cylinder with completed threaded and galvanized tie rods type "S6")
 Ø32 ÷ 63 require stainless steel tube.
 Please contact our sales offices.

ASSEMBLY:
 CX/CPU/CT Ø + cylinder CPU S6
 type MF/CX/CPU/CT Ø

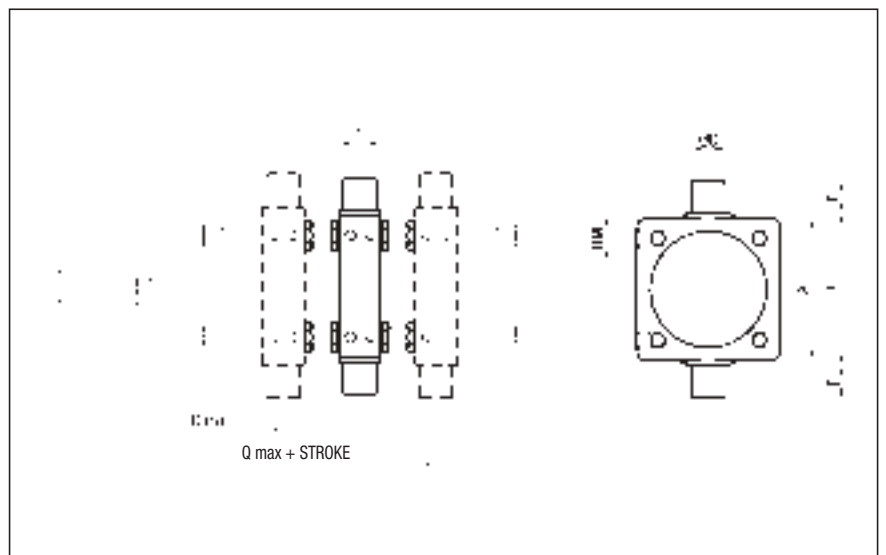

Compact cylinders to ISO 21287 standard

series BX

1

DESCRIPTION

Cylinders series "BX" comply with ISO 21287 standard and they are available from Ø 20 to Ø 100, and they are supplied with magnetic piston type as standard. The barrel, in extruded aluminium alloy, has some TEE-slots on the sides that can host directly the magnetic sensors series "FM100".



TECHNICAL DATA

Operating pressure	Single acting 2÷10 bar - Double acting 1÷10 bar
Working temperature	0 ÷ +80 °C (-20 °C with dry air)
Fluid	Filtered, un lubricated, continuous lubricated, or dry compressed air
Versions	Double acting, Single acting front spring, Single acting rear spring, Through rod, Double push tandem, Double stroke tandem, Opposed tandem, Non rotating piston rod device
Bore	Ø 20, 25, 32, 40, 50, 63, 80, 100
Port size	Ø 20 - 25 = M5; Ø 32 ÷ 100 = G 1/8
Standard strokes (mm)	Ø 20 - 25 = 5, 10, 15, 20, 25, 30, 40, 50, 60, 80, 100, 125, 150 Ø 32 ÷ 63 = 5, 10, 15, 20, 25, 30, 40, 50, 60, 80, 100, 125, 150, 200, 250, 300 Ø 80 ÷ 100 = 5, 10, 15, 20, 25, 30, 40, 50, 60, 80, 100, 125, 150, 200, 250, 300, 350, 400
Max. stroke single acting (mm)	Ø 20 ÷ 100 = 25
Max. stroke no rotating (mm)	Ø 20 - 25 = 40; Ø 32 ÷ 100 = 80
Spring theoretical tractive force	See technical data on page 0.13

ORDER KEY

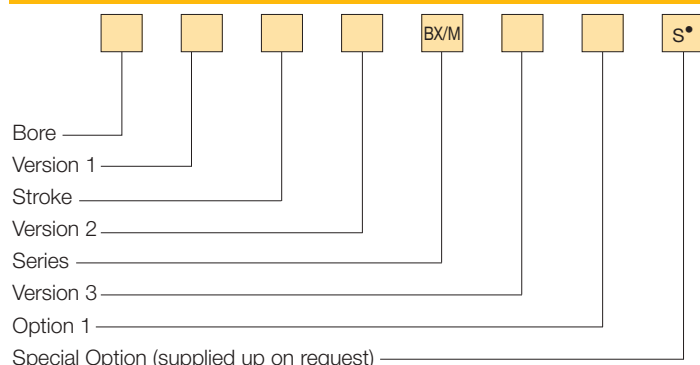

• See Chapter 1 on page 1.1.

ORDER EXAMPLES

Basic cylinder Ø 50, 50 mm stroke, double acting, magnetic piston type, female threaded piston rod: **50/50 DBX/M8**

Cylinder Ø 63, through rod, 80 mm stroke, double acting, magnetic piston type, stainless steel rod and male threaded piston rod: **63R80 DBX/M17**

Cylinder Ø 80, double stroke push tandem, 50 mm stroke 1 + 100 mm stroke 2, double acting, magnetic piston type, female threaded piston rod: **80P50+100 DBX/M8**

MATERIALS

End Caps	Die-cast aluminium alloy
Cylinder barrel	Extruded profile, 20 µm anodized aluminium alloy
Screws	Steel
Piston rod	AISI 303 rolled stainless steel
Rod nut	Steel Stainless steel
Piston rod bearing	Self lubricating sintered bronze
Piston	NBR rubber block (supplied with magnet)
Seals	NBR rubber Polyurethane
Springs	Springs steel

VERSION 1

/ Basic cylinder	V Opposed tandem
R Through rod	P Double stroke tandem
T Double push tandem	

VERSION 2

D Double acting	Y Single acting rear spring
S Single acting front spring	

VERSION 3

A Non-rotating piston rod device (supplied only with female threaded piston option)

OPTION 1

7 Male threaded piston rod	8 Female threaded piston rod
----------------------------	------------------------------

SPARE PARTS

SEALS KIT	
Polyurethane - NBR	Ø/SG/BX
Through rod polyurethane - NBR	Ø/SG/R/BX

POSITION OF THE SLOTS FOR MAGNETIC SENSORS

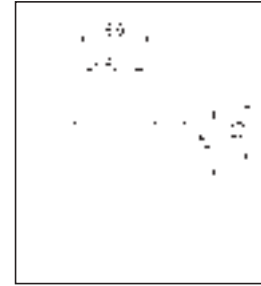
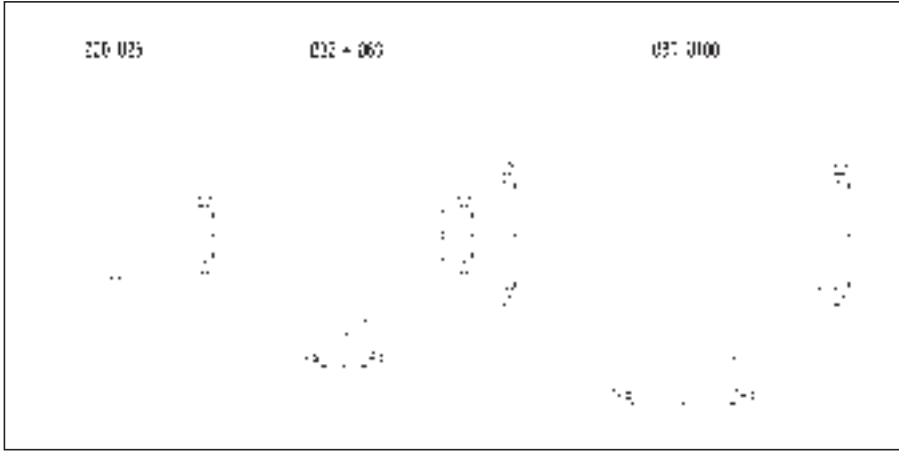

BX BASIC CYLINDER

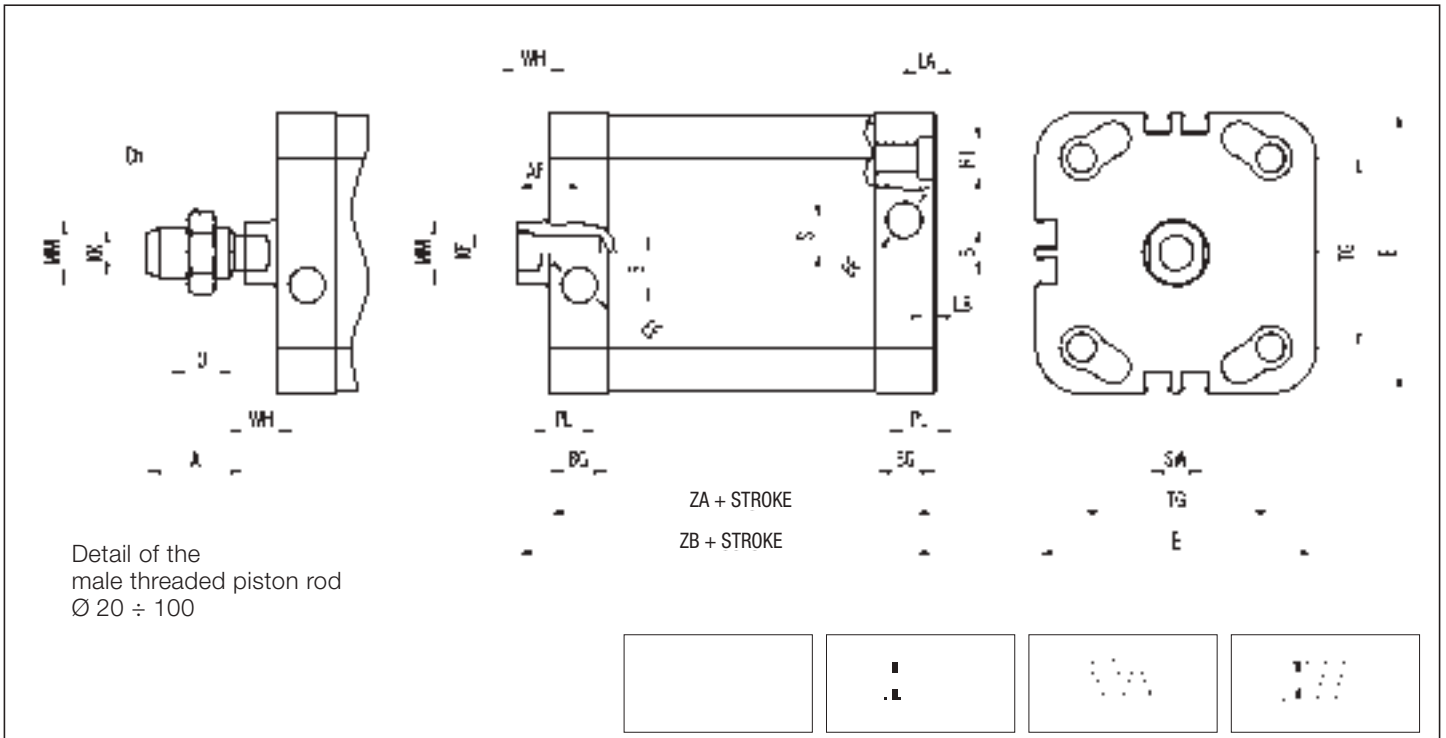

P.S.: Rod nut supplied as standard

DIMENSIONS AND WEIGHTS BASIC CYLINDER

Ø	A	AF	B	BG*	CH	E	EE	KF	KK	LA	LB	MM	O	PL	RT	S	SW	TG	WH	ZA	ZB	ZT	WEIGHT (g)		INCR. (g) x 5 mm
																							A	AF	
20	16	10	9	14,25	13	36	M5	M6	M8	3	2,1	10	5	7	M5	2,5	9	22	6	37	43	74	123	115	10
25	16	10	9	14	13	39,5	M5	M6	M8	3	2,1	10	5	7	M5	2,5	9	26	6	39	45	78	150	142	11
32	19	12	9	15,5	17	49,5	G 1/8	M8	M10 X 1,25	3,5	2,1	12	6	7,75	M6	6	10	32,5	7	44	51	88	256	240	16,5
40	19	12	9	15,5	17	54	G 1/8	M8	M10 X 1,25	3,5	2,1	12	6	7,75	M6	8	10	38	7	45	52	90	296	280	16
50	22	16	12	14,5	19	69	G 1/8	M10	M12 X 1,25	4	2,6	16	7	7,5	M8	8	13	46,5	8	45	53	90	501	473	26
63	22	16	12	15,5	19	79	G 1/8	M10	M12 X 1,25	4	2,6	16	7	7,75	M8	11,5	13	56,5	8	49	57	98	703	676	28
80	28	20	12	17,5	24	94,5	G 1/8	M12	M16 X 1,5	5	2,6	20	8	8,75	M10	11,5	17	72	10	54	64	108	1147	1089	40
100	28	20	12	21	24	114,5	G 1/8	M12	M16 X 1,5	5	2,6	25	8	10,5	M10	20	21	89	10	67	77	134	2164	2068	56

**SINGLE ACTING
REAR SPRING**

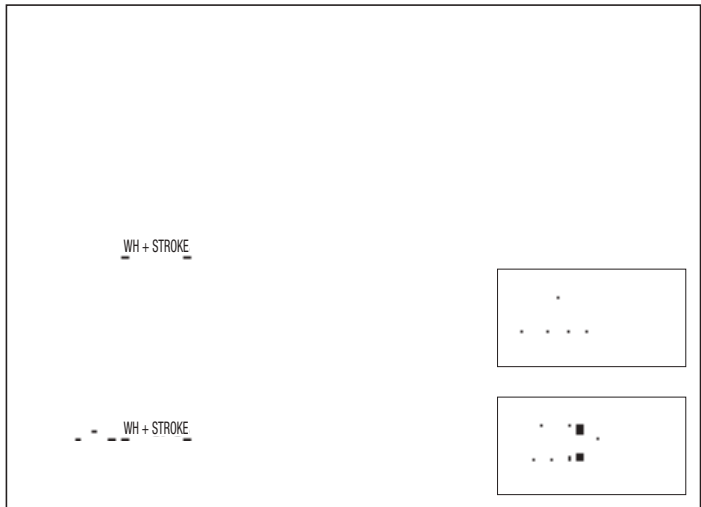

P.S.: Rod nut supplied as standard

**THROUGH ROD AND
SINGLE ACTING THROUGH ROD**

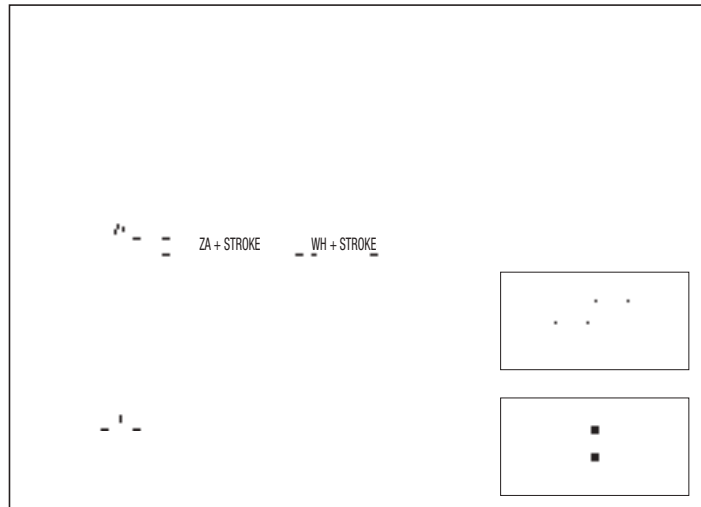

P.S.: Rod nut supplied as standard

**DOUBLE PUSH
TANDEM**

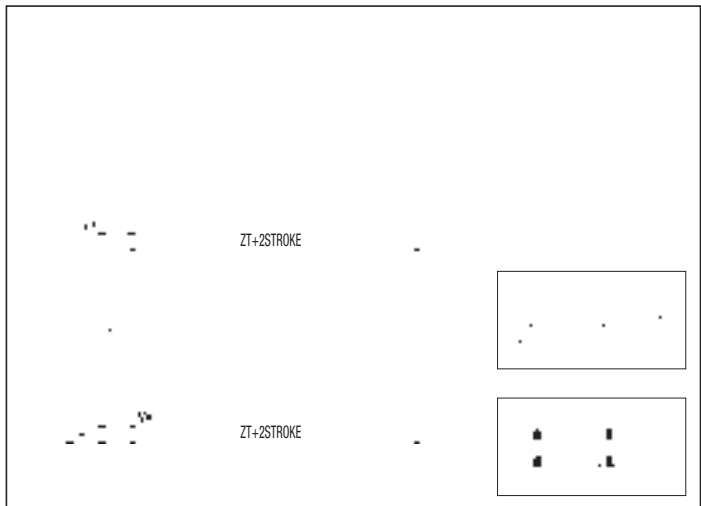

P.S.: Rod nut supplied as standard

**DOUBLE STROKE
TANDEM**

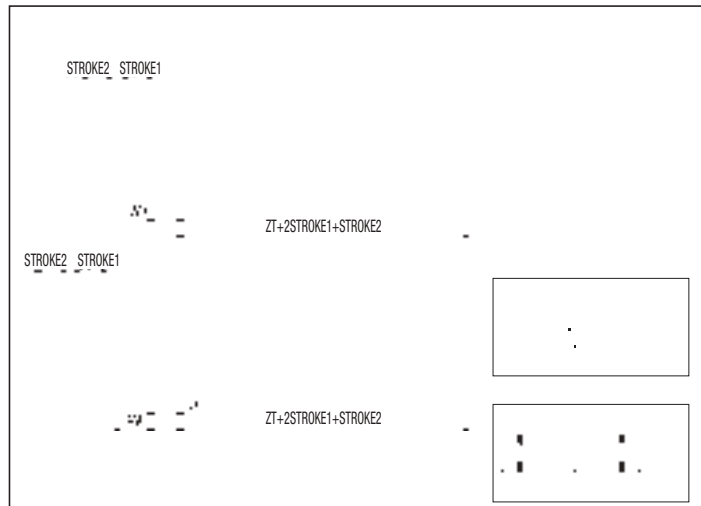

**OPPOSED
TANDEM**



P.S.: Rod nut supplied as standard

BX NON-ROTATING BASIC CYLINDER

1

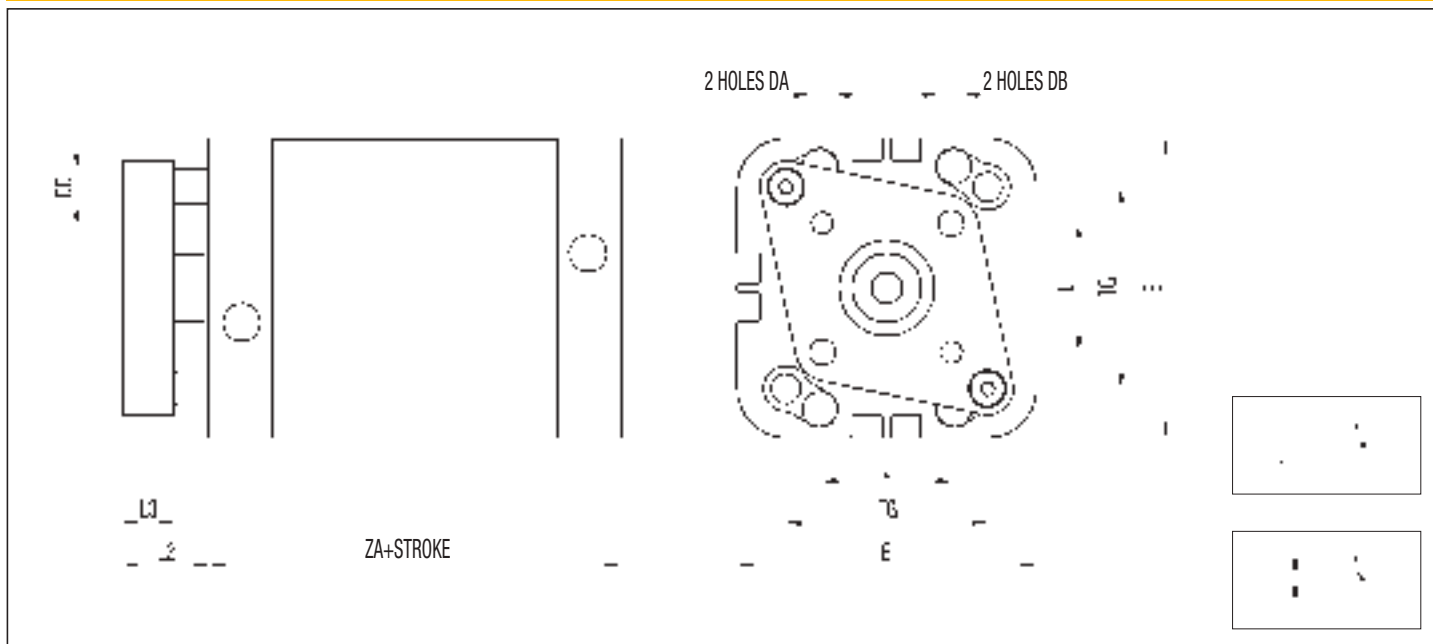

DIMENSIONS AND WEIGHTS

Ø	DA	DB	DC	E	L	L2	L3	TG	ZA	WEIGHT (g)	INCR. (g) x 5 mm
20	M4	4	5	36	12	14	8	22	37	139	10
25	M5	5	5	39,5	15,5	14	8	26	39	165	11
32	M5	5	5	49,5	19,8	17	10	32,5	44	287	16,5
40	M5	5	6	54	23,3	17	10	38	45	336	16
50	M6	6	8	69	29,7	20	12	46,5	45	574	26
63	M6	6	8	79	35,4	20	12	56,5	49	804	28
80	M8	8	10	94,5	46	24	14	72	54	1363	40
100	M10 X 1,25	10	10	114,5	56,6	24	14	89	67	2446	56

MAX PERMISSIBLE LOAD - NON ROTATING BX

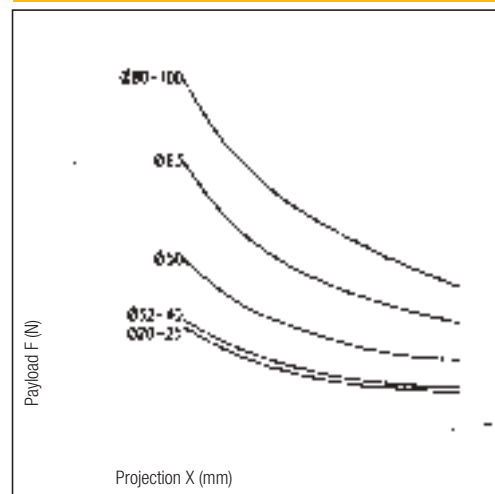

Accessories

BX - Fixings for compact cylinders to ISO 21287 standards

FLANGE Ø 20-25 - ALUMINIUM - BX/F Ø
(Supplied with screws) - STEEL - BX/F Ø AC

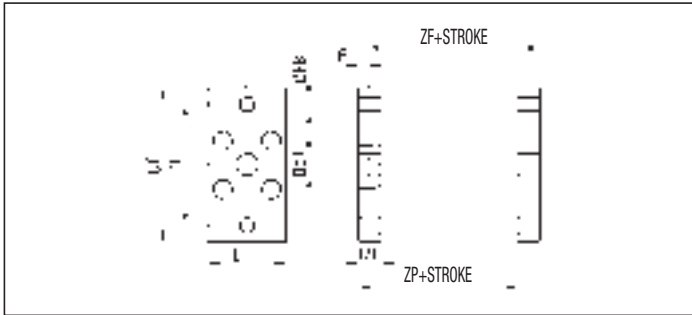

Ø	d1 H11	E	FB H13	MF	P	R	TF	UF	ZF	ZP	WEIGHT ALL (g)	WEIGHT STEEL (g)
20	12	36	6,6	10	4	-	55	70	53	47	70	160
25	12	40	6,6	10	4	-	60	76	55	49	80	200

LOW FOOT - STEEL - BX/PB Ø (Supplied with screws)

Ø	AB H13	AH	AU	AT	E	F	SA	TR	WEIGHT (g)
20	6,6	27	16	4	36	22	69	22	32
25	6,6	30	16	4	40	22	71	26	38

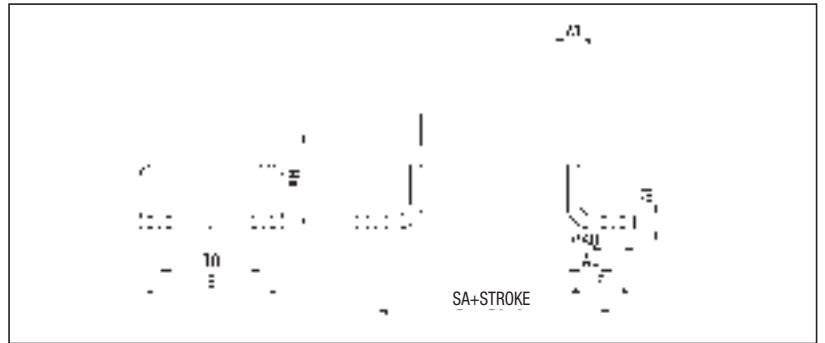

REAR MALE HINGE - ALUMINIUM - BX/CM Ø
(Supplied with screws) - STEEL - BX/CM Ø AC

Ø	CD H9	E	EW h14	FL	L	L2	XD	WEIGHT ALL (g)	WEIGHT STEEL (g)
20	8	34	16	20	14	2,6	63	21	80
25	8	38	16	20	14	2,6	65	27	85

PS.: THIS MOUNTING CAN BE USED WITH THE REAR HINGE MOUNTING OF CYLINDERS SERIES "U" (SEE ON PAGE 1.6)

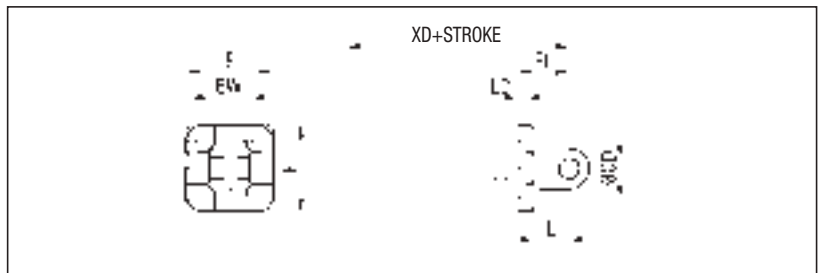

FLOATING HINGE - STEEL - BX/CTA Ø (Supplied with screws)

Ø	L1	P	TD e9	TL h14	TM h14	UW	XV	WEIGHT (g)
20	14	8	12	12	38	35	57	100
25	14	8	12	12	42	39	59	114

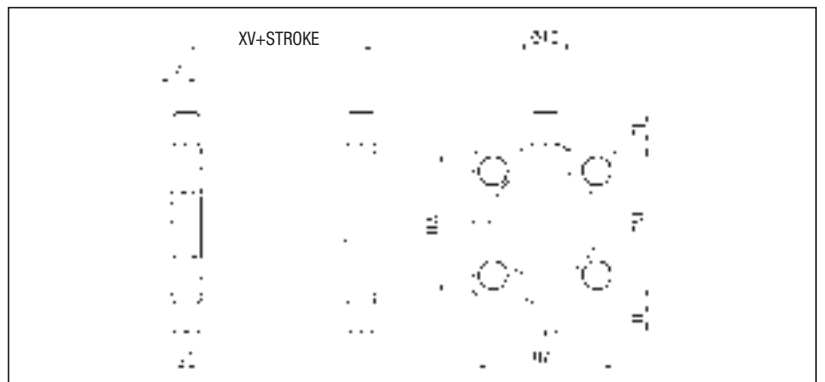

PS.: Only for Ø 32 ÷ 100 use the accessories of the series CPUI. See from page 1.33.

series ABX

Stainless steel
compact cylinders
to ISO 21287 standard

DESCRIPTION

Stainless steel compact cylinders series "ABX" comply with ISO 21287 standard and they are available from Ø20 to Ø100. Besides from Ø125 to Ø200 they are available with end caps distance between centers to ISO 15552 standard. Cylinders series "ABX" have magnetic piston as standard and so they can be supplied with magnetic sensors.



TECHNICAL DATA

Operating pressure	Single acting: 2 ÷ 10 bar Double acting: 1 ÷ 10 bar
Working temperature	0 ÷ +80 °C (with dry air -30 °C) 0 ÷ +200 °C with seals for high temperature (with dry air -10 °C)
Fluid	Compressed air, filtered, continuous lubricated, unlubricated or dry lubricated
Versions	Double acting, Single acting front spring, Single acting rear spring, Through rod
Bore	Ø 20, 25, 32, 40, 50, 63, 80, 100, 125, 160, 200
Port size	Ø 20 - 25 = M5 Ø 32 - 100 = G 1/8 Ø 125 = G 1/4 Ø 160 - 200 = G 3/8
Standard strokes (mm)	10, 25, 50, 75, 100, 125, 160, 200, 250, 300
Maximum strokes (mm)	Ø 20 - 25 = 200 Ø 32 - 40 = 250 Ø 50 ÷ 200 = 300
Max. strokes single acting (mm)	Ø 20 ÷ 100 = 25

MATERIALS

End caps	Ø 20 ÷ 100 = AISI 316 stainless steel Ø 125 ÷ 200 = AISI 304 stainless steel
Cylinder barrel	Ø 20 ÷ 100 = AISI 316 stainless steel extruded tube Ø 125 ÷ 200 = AISI 304 stainless steel extruded tube
Tie rods, tie and rod nuts	Ø 20 ÷ 100 = AISI 316 stainless steel Ø 125 ÷ 200 = AISI 304 stainless steel
Piston rod	Ø 20 ÷ 100 = AISI 316 stainless steel Ø 125 ÷ 200 = AISI 304 stainless steel
Rod nut	Ø 20 ÷ 100 = AISI 316 stainless steel Ø 125 ÷ 200 = AISI 304 stainless steel
Piston rod bearing	Bronze + PTFE
Piston	Aluminium alloy
Seals	Poliurethane FKM (Viton®)
Springs	Zinc-plated springs steel

ORDER KEY

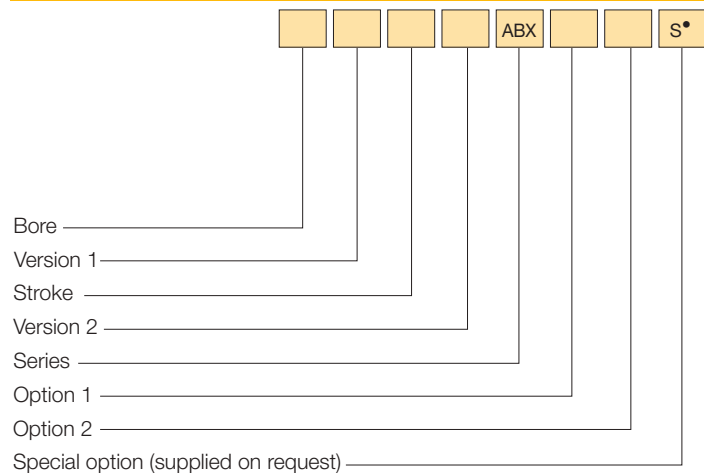

• See Chapter 1, page 1.1.

VERSION 1

/ Basic cylinder R Through rod

VERSION 2

D Double acting Y Single acting rear spring*
S Double acting front spring*

OPTION 1

2 Seals for high temperature**

OPTION 2

7 Male threaded piston rod 8 Female threaded piston rod

* Supplied from Ø 20 ÷ 100.

** Available even with FKM (Viton®) seals but just for application where is needed a chemical compatibility; not available for high temperature.

ORDERS EXAMPLES

Basic cylinder Ø 50, 50 mm stroke, double acting, female threaded piston rod: **50/50 DABX8**

Basic cylinder Ø 32, 25 mm stroke, simple acting front spring, male threaded piston rod: **35/25 SABX7**

SPARE PARTS

SEALS KIT

Polyurethane
Through rod, polyurethane
For high temperature
Through rod for high temperature

Ø/SG/ABX
Ø/SG/R/ABX
Ø/SG/ABX2
Ø/SG/R/ABX2

ABX BASIC CYLINDER

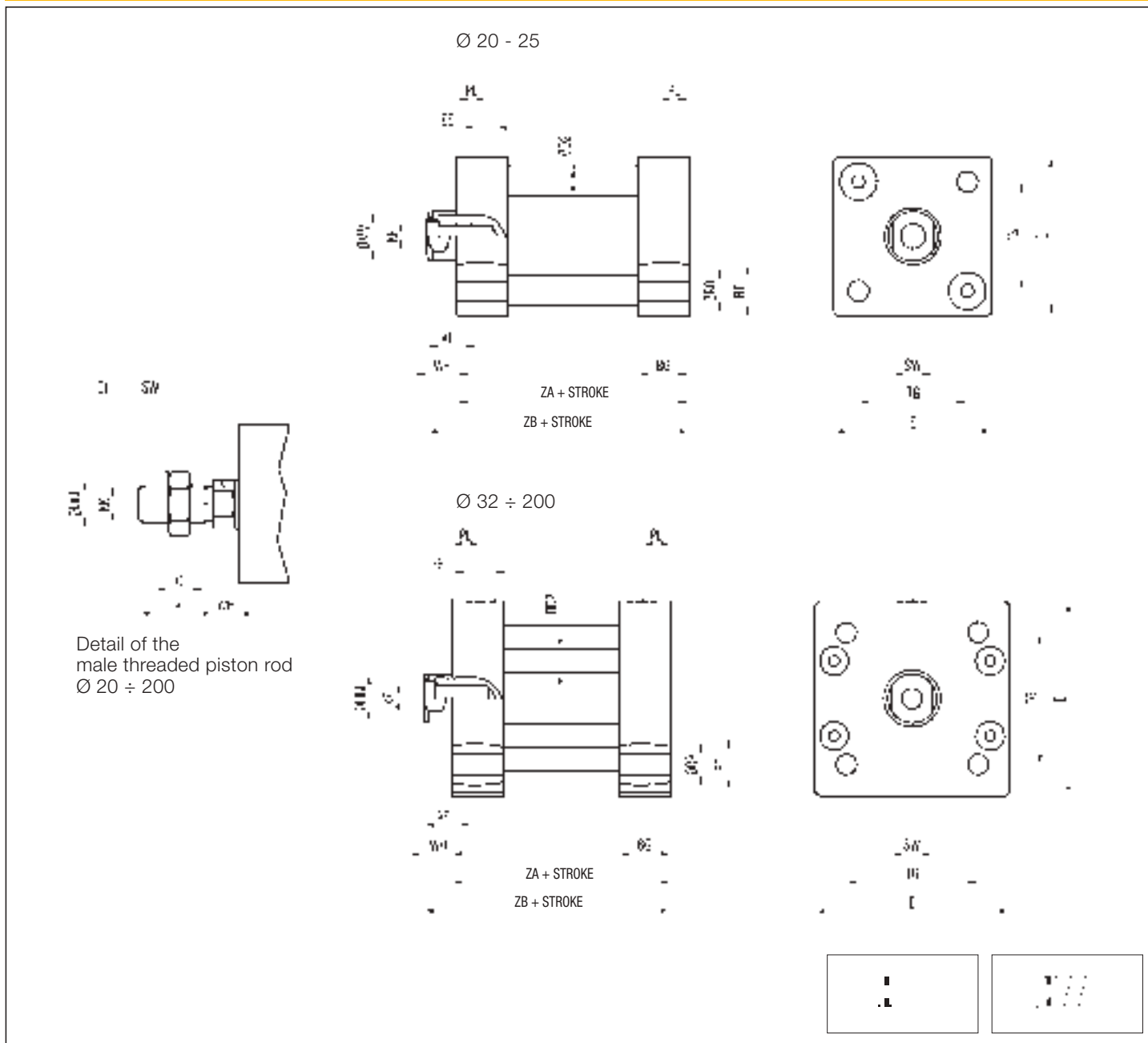

P.S.: Rod nut supplied as standard

DIMENSIONS AND WEIGHTS BASIC CYLINDER

Ø	A	AF	BG	CH	D2	DT	E	EE	KF	KK	LA	MM	O	PL	RR	RT	SW	TG	WH	ZA	ZB	WEIGHT (g)		INCR. (g) x 5 mm
																						A	AF	
20	16	10	10,4	13	6	7,5	32	M5	M6	M8	4,5	10	5	6	4,2	M5	8	22	6	37	43	295	289	8
25	16	10	10,4	13	6	7,5	32	M5	M6	M8	4,5	10	5	6	4,2	M5	8	26	6	39	45	349	343	13,5
32	19	12	12,9	17	6	-	49	G 1/8	M8	M10x1,25	-	12	6	7	5,3	M6	10	32,5	7	44	51	693	674	17,5
40	19	12	13,2	17	6	-	56	G 1/8	M8	M10x1,25	-	12	6	7	5,2	M6	10	38	7	45	52	901	882	19
50	22	16	13,2	19	7	-	66	G 1/8	M10	M12x1,25	-	16	7	7	6,7	M8	13	46,5	8	45	53	1238	1204	27
63	22	16	13,2	19	7	-	78	G 1/8	M10	M12x1,25	-	16	7	7	6,7	M8	13	56,5	8	49	57	1911	1877	38
80	28	20	13,3	30	10	-	98	G 1/8	M12	M12x1,25	-	20	8	7,5	8,5	M10	17	72	10	54	64	2702	2660	57
100	28	24	17,6	30	10	-	116	G 1/8	M12	M16x1,5	-	25	8	9,5	8,5	M10	21	89	10	67	77	4842	4760	72
125	54	25	22	41	10	-	140	G 1/4	M14	M27x2	-	30	12	10	10,2	M12	28	110	10	78	88	8243	7890	97
160	72	30	26	55	12	-	180	G 3/8	M20	M36x2	-	40	14	12	14,2	M16	36	140	12	87	99	16100	15290	147,5
200	72	30	26	55	14	-	220	G 3/8	M20	M36x2	-	40	14	12	14,2	M16	36	175	12	87	99	24250	23440	225

1

SINGLE ACTING REAR SPRING

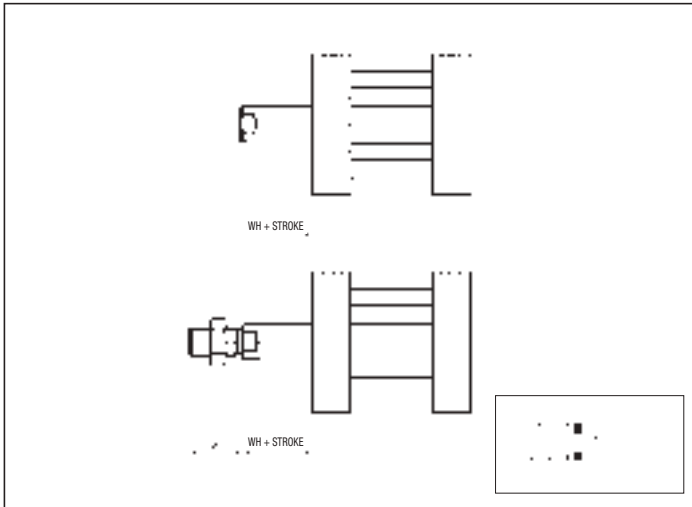

P.S.: Rod nut supplied as standard

THROUGH ROD

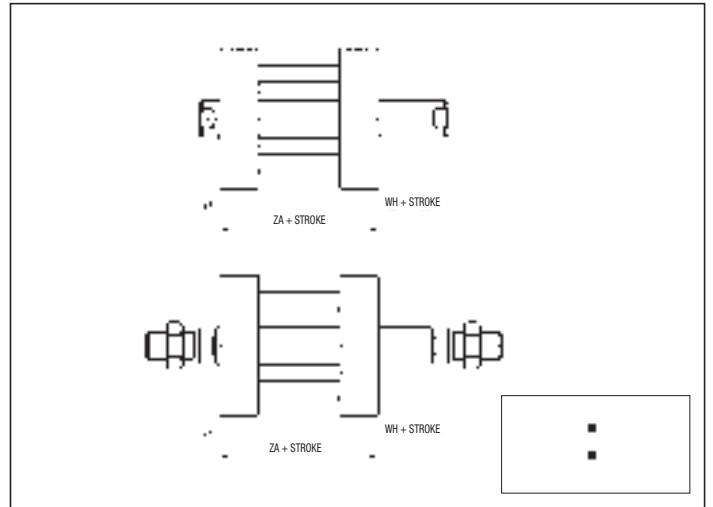

P.S.: Rod nut supplied as standard

P.S.: accessories for series **AX** can just be used for $\varnothing 32 \div 200$. - See from page 1.52.

Compact cylinders to AFNOR NF E49-004-1 and NF E49-004-2 standards

series BU

DESCRIPTION

Cylinders series "BU" are available from Ø 20 to Ø 100 and, complying with AFNOR NF E49-004-1 and NF E49-004-2 standards, they are interchangeable also without using the fixing accessories. The extruded aluminium alloy barrel has some TEE-slots on the sides where it's possible to mount directly the magnetic sensors series "FM100". Upon request, cylinders series "BU" comply with ATEX directive, 2GD category.

TECHNICAL DATA

Operating pressure	Single acting 2 ÷ 10 bar - Double acting 1 ÷ 10 bar
Working temperatures	0 ÷ +80 °C (-20 °C with dry air) 0 ÷ +130 °C with seals for high temperatures (-10 °C with dry air; for single acting versions: max 100 °C)
Fluid	Filtered, unlubricated or continuous lubricated compressed air
Versions	Double acting, Single acting front spring, Single acting rear spring, Through rod, Double push tandem, Double stroke tandem, Opposed tandem, Non-rotating piston rod device, Hollow through rod, Distance between centers to ISO standard
Bore	Ø 20, 25, 32, 40, 50, 63, 80, 100
Port size	Ø 20 - 25 = M5; Ø 32 ÷ 100 = G 1/8
Standard strokes (mm)	5, 10, 15, 20, 25, 30, 35, 40, 45, 50, 55, 60, 65, 70, 75, 80, 100, 125, 150, 160, 200, 250, 300, 320, 350, 400
Maximum strokes (mm)	Ø 20 - 25 = 200; Ø 32 ÷ 63 = 300; Ø 80 - 100 = 400
Max. strokes single acting (mm)	Ø 20 ÷ 100 = 25
Max. strokes hollow through rod (mm)	Ø 20 ÷ 32 = 40; Ø 40 ÷ 63 = 60; Ø 80 - 100 = 80
Max. strokes non-rotating (mm)	Ø 20 - 25 = 40; Ø 32 ÷ 100 = 80
Spring theoretical tractive force	See technical data on page 0.13

ORDER KEY

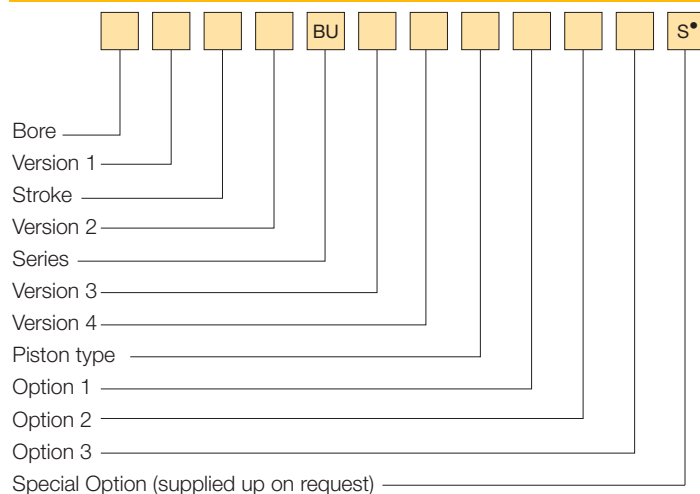

• See Chapter 1 on page 1.1.

ORDER EXAMPLES

Basic cylinder Ø 50, 50 mm stroke, double acting, magnetic piston type, female threaded piston rod: **50/50 DBU/M8**.

Cylinder Ø 63, through rod, 80 mm stroke, double acting, magnetic piston type, stainless steel and male threaded piston rod, ATEX: **63R80 DBU/M17/EX**.

Cylinder Ø 80, double stroke tandem, 50 mm stroke 1 + 100 mm stroke 2, double acting, magnetic piston type, female threaded piston rod: **80P50 + 100 DBU/M8**.



MATERIALS

End caps	Extruded profile, anodized aluminium alloy
Cylinder barrel	Extruded profile, 20 µm anodized aluminium alloy
Screws	Steel
Piston rod	Ø 20 - 25 = AISI 303 rolled stainless steel Ø 32 ÷ 100 = C45 chromium-plated steel
Rod nut	Steel Stainless steel
Piston rod bearing	Self-lubricating sintered bronze
Piston	Ø 20 - 25 = zinc-plated steel (supplied with and without magnet) Ø 32 ÷ 100 = aluminium alloy (supplied with and without magnet)
Seals	Polyurethane
Springs	Springs steel

VERSION 1

/ Basic cylinder	T Double push tandem
R Through rod	P Double stroke tandem
F Hollow through rod	V Opposed tandem

VERSION 2

D Double acting	Y Single acting rear spring
S Single acting front spring	

VERSION 3

I End caps distance between centers to ISO 15552 standard (Ø32÷100)

VERSION 4

A Non-rotating piston rod device (supplied only with female threaded piston rod option)

PISTON TYPE

Non-magnetic	/M Magnetic
--------------	-------------

OPTION 1

1 Stainless steel piston rod and rod nut*	3 Stainless steel piston rod and rod nut and seals for high temperatures**
2 Seals for high temperatures**	

OPTION 2

7 Male threaded piston rod	8 Female threaded piston rod
----------------------------	------------------------------

OPTION 3

/EX Consistent with the ATEX directive II 2GD c T5 T100°C -20°C<Ta<80°C

* Supplied only from Ø 20 and Ø 25

** Supplied only with non-magnetic piston type

SPARE PARTS

SEALS KIT			
Polyurethane	Ø/SG/BU	Through rod, polyurethane	Ø/SG/R/BU
For high temperatures	Ø/SG/BU2	Through rod, for high temperatures	Ø/SG/R/BU2

series BU

Compact cylinders
to AFNOR NF E49-004-1
and NF E49-004-2 standards

DISPOSITION OF THE SLOTS FOR MAGNETIC SENSORS AND DIMENSION LD

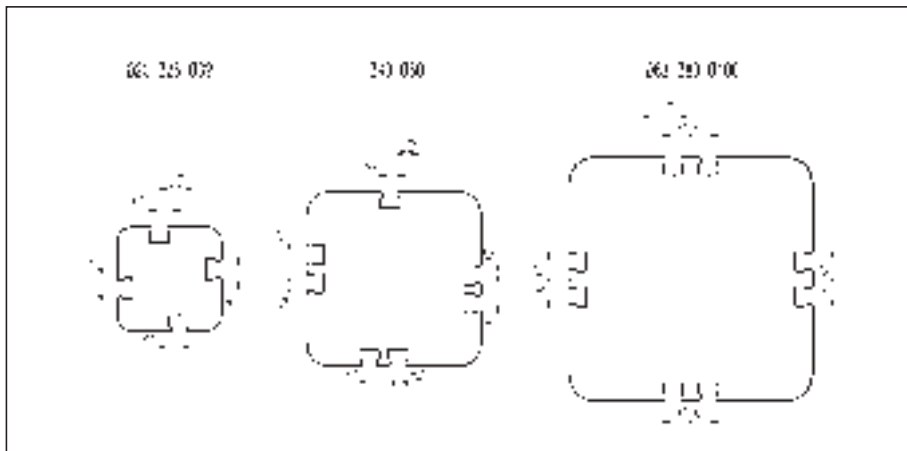

Ø	K1	K2
20	3,4	-
25	4	-
32	4	-
40	8,4	1,4
50	7,6	3,2
63	6	-
80	8	-
100	8	-

1

BU BASIC CYLINDER

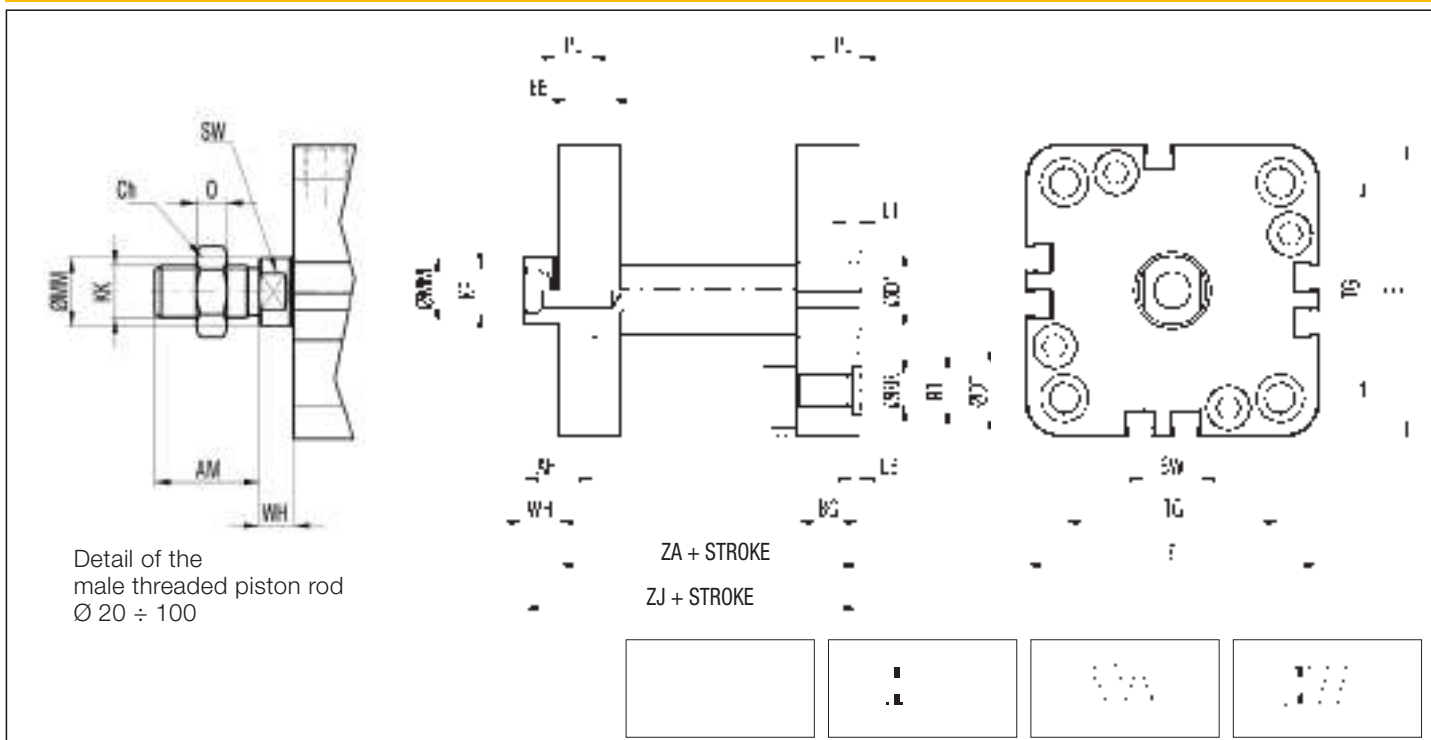

P.S.: Rod nut supplied as standard

DIMENSIONS AND WEIGHTS BASIC CYLINDER

Ø	AF	AM	BG*	CH	D	D1 H11	DT H13	E	EE	KF	KK	LB	LD	L1	MM	O	PL	RR	RT	SW	TG		WH	ZA	ZB	ZJ	WEIGHT (g)		INCR. (g) x 5 mm
																					A	I					AF	AM	
20	11,5	22	12	17	3,8	12	8	36	M5	M6	M10x1,25	4,4	4,5	2,5	10	6	7	4,3	M5	8	22	-	6	37	62	43	130	150	10
25	11,5	22	13	17	3,8	12	8	40	M5	M6	M10x1,25	4,4	4,5	2,5	10	6	8	4,3	M5	8	26	-	6	39	65	45	160	180	11
32	13	22	14,5	17	4,5	14	10,5	50	G1/8	M8	M10x1,25	5,4	5	2,5	12	6	7,5	5,3	M6	10	32	32,5	7	44	73,5	51	215	240	16
40	13	22	14,5	17	4,5	14	10,5	60	G1/8	M8	M10x1,25	5,4	9,5	2,5	12	6	7,5	5,3	M6	10	42	38	7	45	75,5	52	330	355	20
50	16,5	24	14,5	19	6	18	11	68	G1/8	M10	M12x1,25	1,7	8,5	2,5	16	7	7,5	6,4	M8	13	50	46,5	8	45	75,5	53	470	505	25
63	16,5	24	14,5	19	6	18	11	84	G1/8	M10	M12x1,25	1,7	17,5	2,5	16	7	7,5	6,4	M8	13	62	65,5	8	50	85,5	58	710	745	37
80	21	32	16,5	24	8	23	15	102	G1/8	M12	M16x1,5	1	21	3	20	8	8,5	8,4	M10	16	82	72	8	56	95,5	64	1295	1360	50
100	24,5	40	19,5	30	10	28	15	123	G1/8	M16	M20x1,5	3,5	25	3	25	9	10	8,4	M10	21	103	89	10	67	114,5	77	2250	2390	70

* IN THE TANDEM VERSIONS (T, P, V), DIMENSION (BG - LB) IS REDUCED OF 5 mm

**SINGLE ACTING
REAR SPRING**

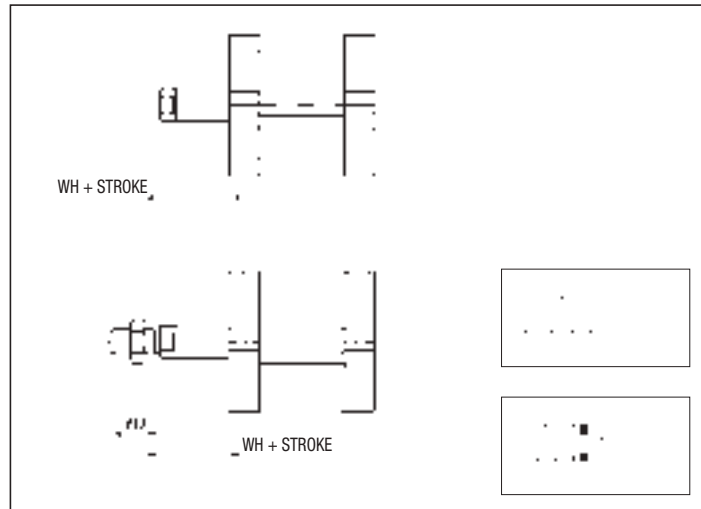

P.S.: Rod nut supplied as standard

**THROUGH ROD
AND SINGLE ACTING THROUGH ROD**

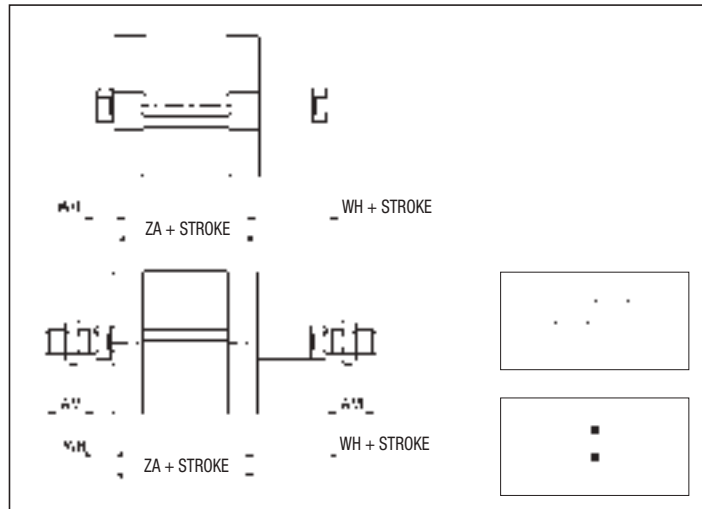

P.S.: Rod nut supplied as standard

**HOLLOW THROUGH ROD
AND SINGLE ACTING HOLLOW THROUGH ROD**

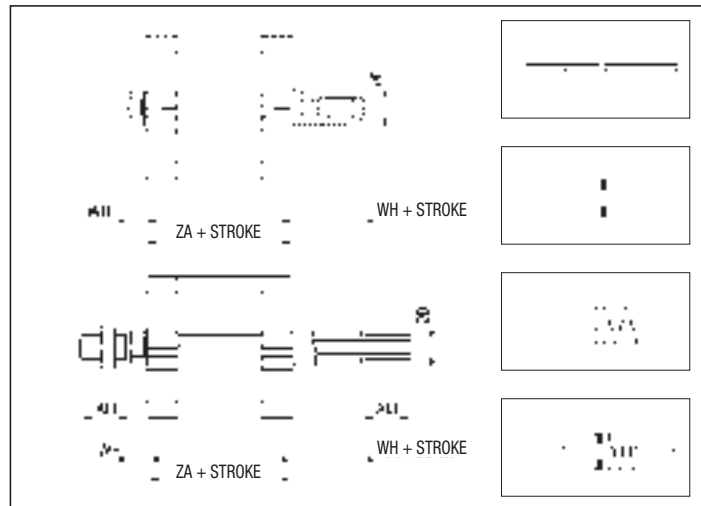

P.S.: Rod nut supplied as standard

**DOUBLE PUSH
TANDEM**

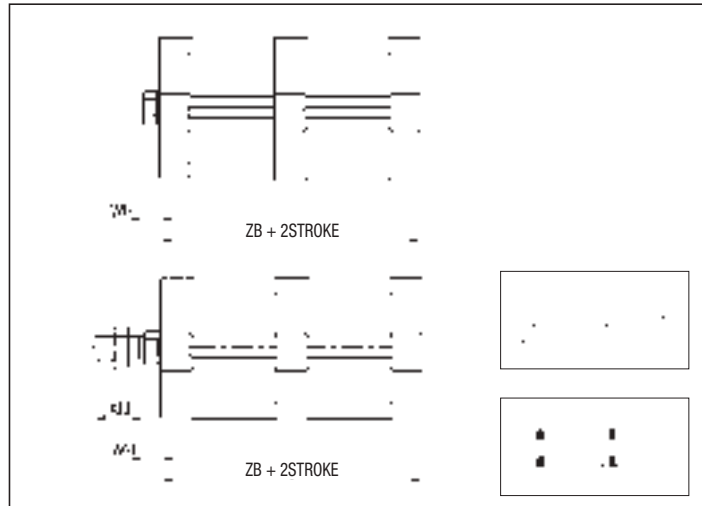

P.S.: Rod nut supplied as standard

**DOUBLE STROKE
TANDEM**

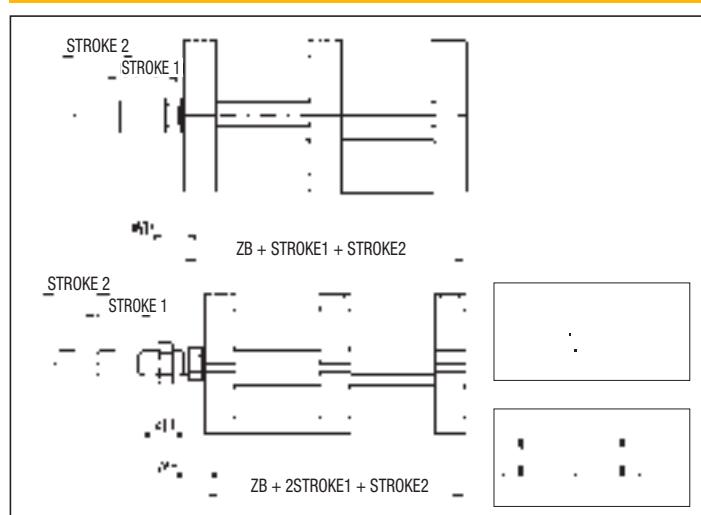

**OPPOSED
TANDEM**

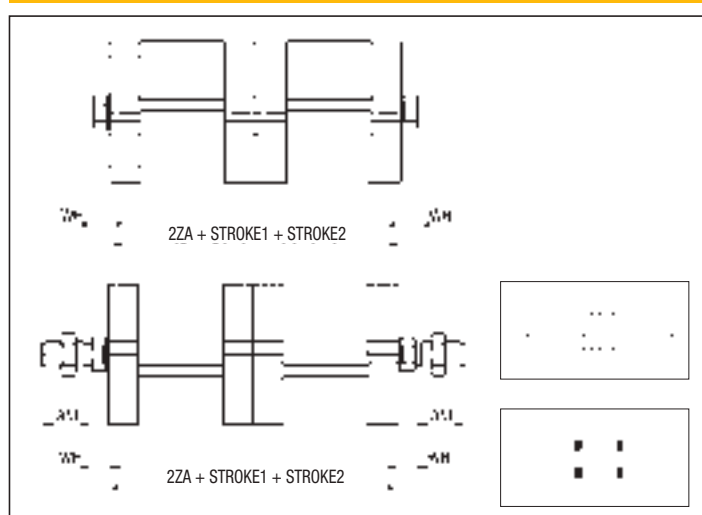

P.S.: Rod nut supplied as standard

BU NON-ROTATING BASIC CYLINDER

1

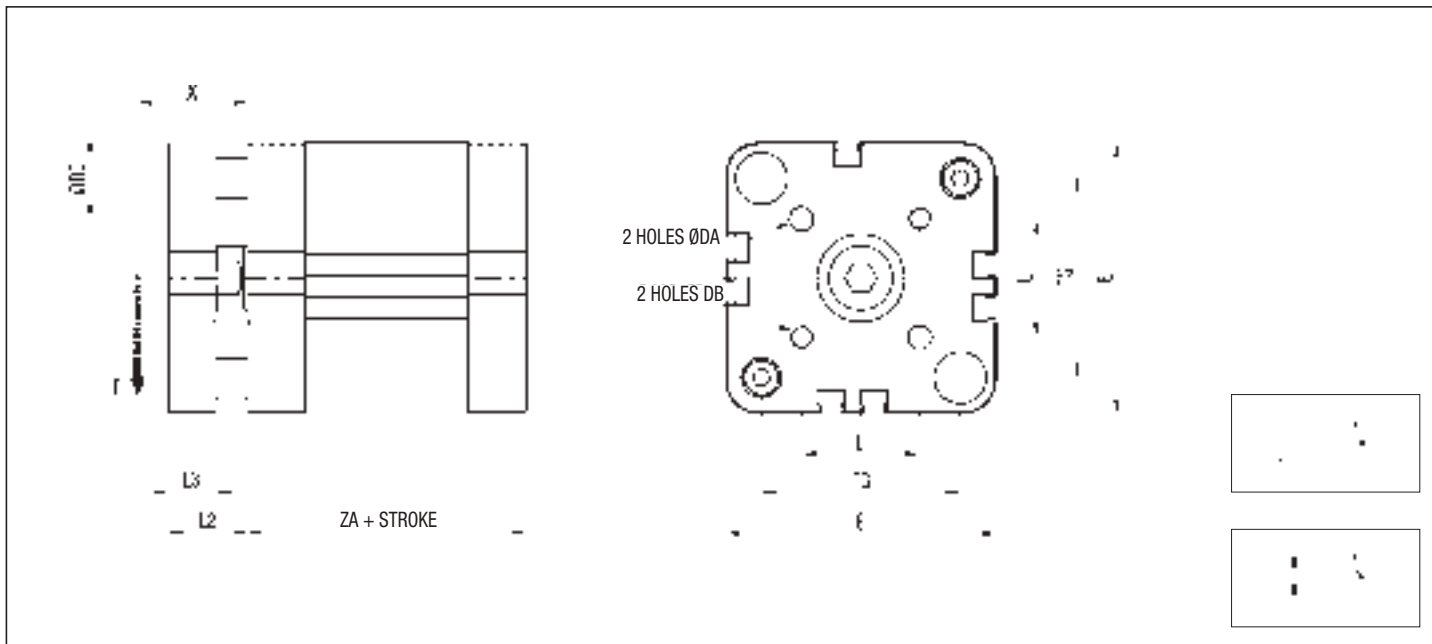

DIMENSIONS AND WEIGHTS

Ø	DA	DB	DC	E	L	L2	L3	TG	ZA	WEIGHT (g)	INCR. (g) x 5 mm
20	4	M4	6	36	12	14	8	22	37	170	15
25	5	M5	6	40	15,6	14	8	26	39	210	16
32	5	M5	8	50	19,8	17	10	32	44	300	25
40	5	M5	8	60	23,3	17	10	42	45	440	30
50	6	M6	10	68	29,7	20	12	50	45	610	40
63	6	M6	10	84	35,4	20	12	62	50	930	55
80	8	M8	12	102	46	22	14	82	56	1690	75
100	10	M10	12	123	56,6	24	14	103	67	2950	105

MAX. PERMISSIBLE LOAD - NON-ROTATING BU

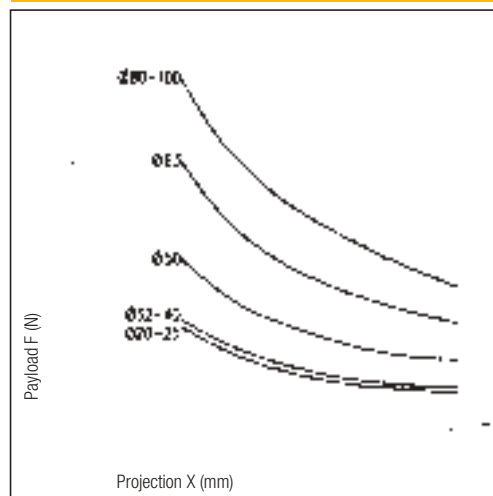

Accessories Fixings for compact cylinders to AFNOR NF E49-004-1 and NF E49-004-2 standards

series BU

1

FLANGE Ø 20-25 - ALUMINIUM - BU/F Ø
(Supplied with screws) - STEEL - BU/F Ø AC

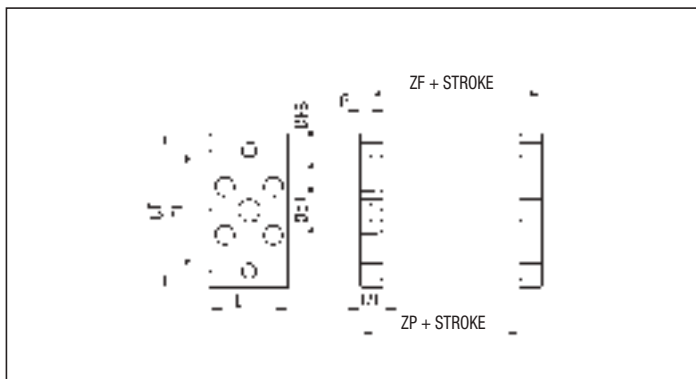

FLANGE Ø 32 ÷ 100 - ALUMINIUM - BU/F Ø
(Supplied with screws) - STEEL - BU/F Ø AC

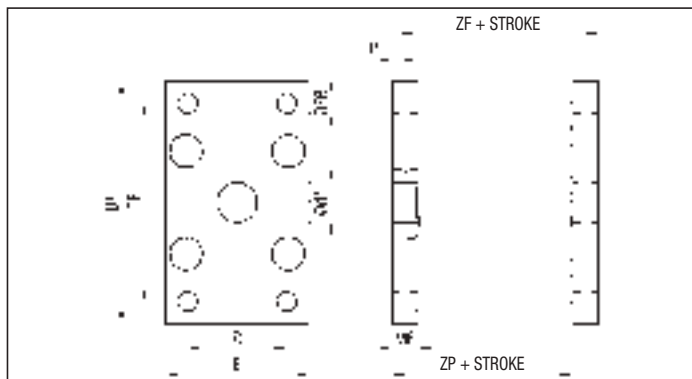

Ø	d1 H11	E	FB H13	MF	P	R	TF	UF	ZF	ZP	WEIGHT ALL (g)	WEIGHT STEEL (g)
20	12	36	6,6	10	4	-	55	70	53	47	70	160
25	12	40	6,6	10	4	-	60	76	55	49	80	200
32	14	50	7	10	3	32	65	80	61	54	100	260
40	14	60	9	10	3	36	82	102	62	55	160	420
50	18	68	9	12	4	45	90	110	65	57	240	600
63	18	87	9	15	7	50	110	130	73	65	450	1200
80	23	107	12	15	7	63	135	160	79	71	690	1800
100	28	128	14	15	5	75	163	190	92	82	980	2550

IN THE TANDEM VERSIONS (T, P, V), ADD THE READING "TANDEM" TO THE CODE.
EXAMPLE: BU/F Ø TANDEM

LOW FOOT - STEEL - BU/PB Ø (Supplied with screws)

Ø	AB H13	AH	AU	AT	E	F	SA	TR	WEIGHT (g)
20	6,6	27	16	4	36	22	69	22	32
25	6,6	30	16	4	40	22	71	26	38
32	6,6	32	18	5	50	26	80	32	66
40	9	42,5	20	5	60	28	85	42	100
50	9	47	24	6	68	32	93	50	150
63	11	59,5	27	6	84	39	104	62	250
80	11	65,5	30	8	102	42	116	82	380
100	13,5	78,5	33	8	123	45	133	103	500

IN THE TANDEM VERSIONS (T, P, V), ADD THE READING "TANDEM" TO THE CODE.
EXAMPLE: BU/PB Ø TANDEM

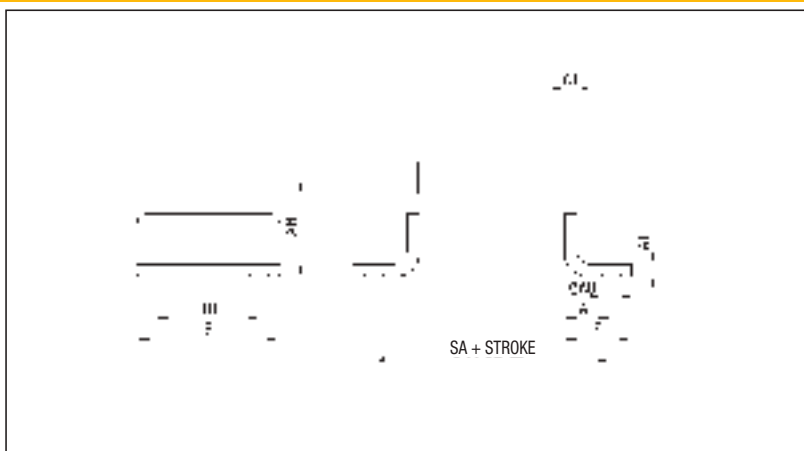

REAR MALE HINGE - ALUMINIUM - BU/CM Ø
(Supplied with screws) - STEEL - BU/CM Ø AC

Ø	CD H9	E	EW h14	FL	L	L2	XD	WEIGHT ALL (g)	WEIGHT STEEL (g)
20	8	34	16	20	14	2,6	63	21	80
25	8	38	16	20	14	2,6	65	27	85

PS.: THIS MOUNTING CAN BE USED WITH THE REAR HINGE MOUNTING OF CYLINDERS SERIES "U" (SEE ON PAGE 1.6)

IN THE TANDEM VERSIONS (T, P), ADD THE READING "TANDEM" TO THE CODE.
EXAMPLE: BU/CM Ø AC TANDEM

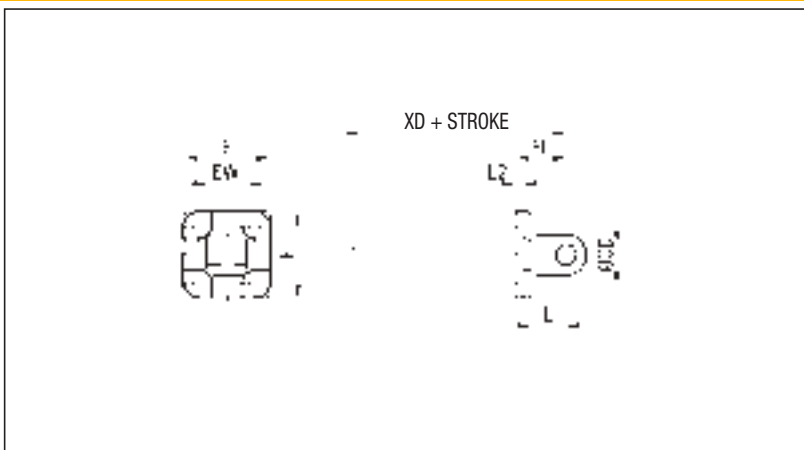

1

REAR FEMALE HINGE (Supplied with screws)

- ALUMINIUM - BU/CF Ø
- STEEL - BU/CF Ø AC

Ø	CB H14	CD H9	E	FL	L	L2	UB h14	XD	WEIGHT ALL (g)	WEIGHT STEEL (g)
32	26	10	48	22	13	5,5	45	73	60	170
40	28	12	58	25	16	5,5	52	77	104	270
50	32	12	66	27	16	6,5	60	80	142	378
63	40	16	83	32	21	6,5	70	90	240	645
80	50	16	102	36	23	10	90	100	420	1070
100	60	20	123	41	26	10	110	118	721	1730

P.S.: THIS HINGE CAN BE USED ALSO WITH PIVOT AND MALE HINGE OR SQUARE JOINT OF THE SERIES CPUI FIXINGS (SEE FROM PAGE 1.33)

IN THE TANDEM VERSIONS (T, P, V),
ADD THE READING "TANDEM" TO THE CODE.
EXAMPLE: BU/CF Ø TANDEM

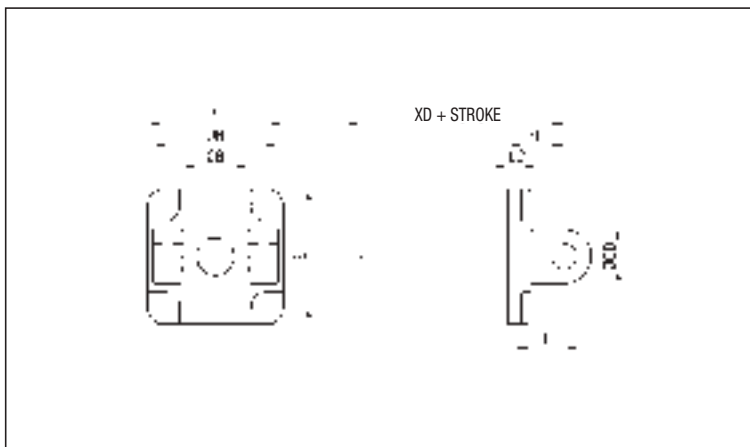

FLOATING HINGE - STEEL - BU/CTA Ø (Supplied with screws)

Ø	L1	P	TD e9	TL h14	TM h14	UW	XV	WEIGHT (g)
20	14	8	12	12	38	35	57	100
25	14	8	12	12	42	39	59	114
32	14	7	12	12	52	46	65	132
40	19	12	16	16	63	59	71	278
50	19	11	16	16	75	69	72	362
63	24	16	20	20	90	84	82	624
80	24	16	20	20	110	102	88	765
100	29	19	25	25	132	125	106	1464

IN THE TANDEM VERSIONS (T, P, V),
ADD THE READING "TANDEM" TO THE CODE.
EXAMPLE: BU/CTA Ø TANDEM

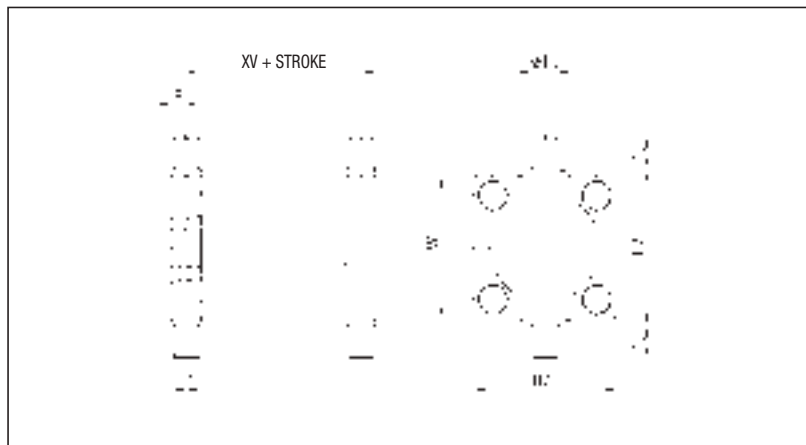

DESCRIPTION

Cylinders series "B" are widely used in locking applications thanks to compact design and to easy mounting through holes on cylinder body. In the version with magnetic piston type, cylinders series "B" are supplied with magnetic sensors.

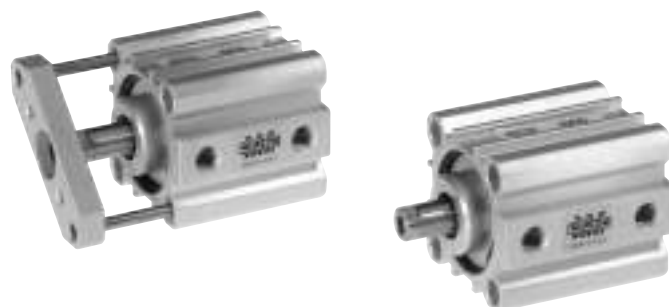

TECHNICAL DATA

Operating pressure	1 ÷ 10 bar
Working temperature	0 ÷ +80 °C (-20 °C with dry air) 0 ÷ +150 °C with seals for high temperatures (-10 °C with dry air)
Fluid	Filtered, unlubricated or continuous lubricated compressed air
Versions	Double acting, Single acting front spring, Single acting rear spring, Through rod, Non-rotating piston rod device
Bore	Ø 12, 16, 20, 25, 32, 40, 50, 63, 80, 100
Port size	Ø 12 ÷ 20 = M5 Ø 25 ÷ 63 = G 1/8 Ø 80 - 100 = G 1/4
Standard strokes	See tables
Spring theoretical tractive force	See technical data on page 0.13

MATERIALS

Front end cap	Ø 12 ÷ 25: Brass Ø 32 ÷ 100: Aluminium
Rear end cap	Anodized aluminium alloy
Cylinder barrel	Extruded profile, 15 µm anodized aluminium alloy
Piston rod	AISI 303 stainless steel
Piston rod bearing	Bronze + PTFE
Piston	Ø 12 ÷ 32: Delrin (supplied with and without magnet) Ø 40 ÷ 100: Aluminium (supplied with and without magnet)
Seals	Ø 12 ÷ 32: NBR rubber Ø 40 ÷ 100: Polyurethane Ø 12 ÷ 100: Viton®
Cushioning washer	Vulkollan
Spring	Stainless steel

ORDER KEY

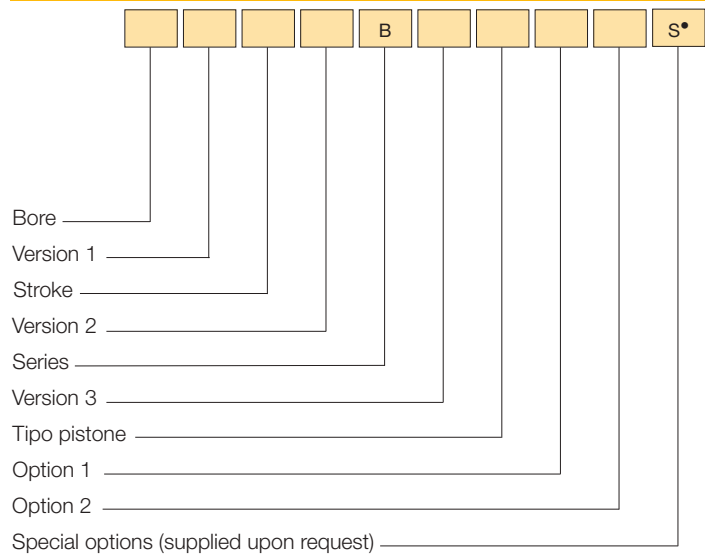

• See Chapter 1 on page 1.1.

VERSION 1

/ Basic cylinder R Through rod

VERSION 2

D Double acting Y Single acting rear spring
S Single acting front spring

VERSION 3

A Non-rotating piston rod device*

PISTON TYPE

Non-magnetic /M Magnetic

OPTION 1

1 Male hinge mounting

OPTION 2

2 Seals for high temperatures

* Supplied only from Ø 20 to Ø 100

ORDER EXAMPLES

Basic cylinder Ø 16, 50 mm stroke, double acting, non-magnetic piston type: **16/50 DB**

Basic cylinder Ø 20, 60 mm stroke, double acting, non-magnetic piston type, seals for high temperatures: **20/60 DB2**

Cylinder Ø32, through rod, 80 mm stroke, double acting, magnetic piston type: **32R80 DB/M**

SPARE PARTS

Contact the commercial office

SINGLE ACTING, DOUBLE ACTING AND SINGLE ACTING MAGNETIC

1

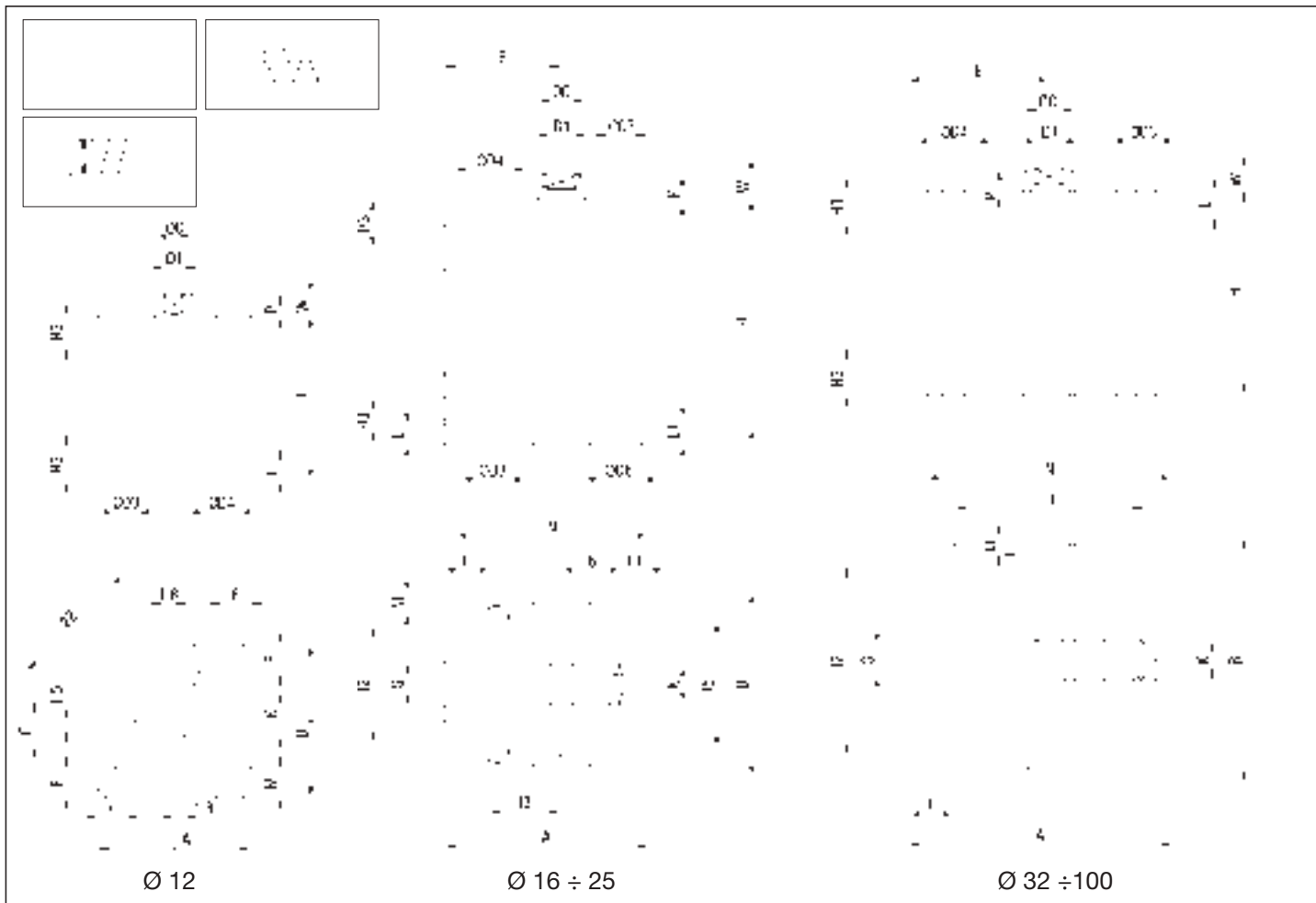

DIMENSIONS AND WEIGHTS

Ø	A	B	D	D1	D3	D4	D7	D8	E	F	F1	G	H3	I1	I2	I3	I5	I6	K	L	L1	M	N	P	W	WEIGHT (g)	INCR. (g) x10 mm
12	25	25	6	M3	3,7	5,6	-	-	-	4,7	-	M5	5,5	-	-	-	-	-	5	3,5	-	4,7	-	6	3,5	33,5	11,5
16	34	30	8	M4	4,7	7,5	3,7	5,6	19	7	5	M5	8	-	18	12	20	10	6	4,6	3,5	4	32	8	4,5	74	16,5
20	40	36	10	M5	5,8	9	5,8	9	22	7	5,2	M5	8	-	20	15	25,5	12,7	8	5,7	5,7	5,7	38,5	10	5	106	24,5
25	44,5	40	10	M5	5,8	9	5,8	9	24,5	9	6	G1/8	10,5	-	26	15,5	28	14	8	5,7	5,7	4,5	42	10	5,5	145	32
32	51	46	12	M6	5,8	9	-	-	27	9	-	G1/8	11,5	36	32	-	-	-	10	5,7	-	4	48	12	6	172	36
40	58	55	12	M6	5,8	9	-	-	30,5	9,5	-	G1/8	11	42	42	-	-	-	10	5,7	-	4	55	12	6	225	40
50	70	65	16	M8	6,8	11	-	-	37,5	12,5	-	G1/8	11,5	50	50	-	-	-	13	6,8	-	4	65	12	7,5	359	63
63	86	80	16	M8	9	14	-	-	46	15	-	G1/8	11	62	62	-	-	-	13	8,8	-	5	80	14	7	552	70
80	105	100	20	M10	9	14	-	-	55	14	-	G1/4	14	82	82	-	-	-	17	9	-	6	100	15	8	1072	105
100	131	124	25	M12	11	17,2	-	-	69	17,5	-	G1/4	16	103	103	-	-	-	22	11	-	7,5	124	20	10	1920	160

H DIMENSION DOUBLE ACTING

Ø	STROKE (mm)										
	5	10	15	20	25	30	40	50	60	80	100
12	22	27	32	37	42	47	57	-	-	-	-
16	32	37	42	47	52	58	68	78	-	-	-
20	32	37	42	47	52	58	68	78	-	-	-
25	33,5	38,5	43,5	48,5	53,5	58,5	69,5	79,5	-	-	-
32	34,5	39,5	44,5	49,5	54,5	59,5	69,5	79,5	89,5	109,5	129,5
40	34,5	39,5	44,5	49,5	54,5	59,5	69,5	79,5	89,5	109,5	129,5
50	-	44,5	49,5	54,5	59,5	64,5	74,5	84,5	94,5	114,5	134,5
63	-	47	52	57	62	67	77	87	97	117	137
80	-	56	61	66	71	76	86	96	106	126	146
100	-	66	71	76	81	86	96	106	116	136	156

H DIMENSION SINGLE ACTING

Ø	STROKE (mm)					
	5	10	15	20	25	30
12	22	27	-	-	-	-
16	32	37	42	47	52	-
20	32	37	42	47	52	-
25	33,5	38,5	43,5	48,5	53,5	-
32	34,5	39,5	44,5	49,5	54,5	59,5
40	34,5	39,5	44,5	49,5	54,5	59,5
50	-	44,5	49,5	54,5	59,5	64,5
63	-	47	52	57	62	67
80	-	56	61	66	71	76
100	-	66	71	76	81	86

H DIMENSION SINGLE ACTING MAGNETIC

Ø	STROKE (mm)					
	5	10	15	20	25	30
12	32	37	-	-	-	-
16	37	42	47	52	63	-
20	37	42	47	52	63	-
25	43,5	48,5	53,5	58,5	64,5	-
32	44,5	49,5	54,5	59,5	64,5	69,5
40	44,5	49,5	54,5	59,5	64,5	69,5
50	-	49,5	54,5	59,5	64,5	69,5
63	-	52	57	62	67	72
80	-	56	61	66	71	76
100	-	66	71	76	81	86

DOUBLE ACTING MAGNETIC

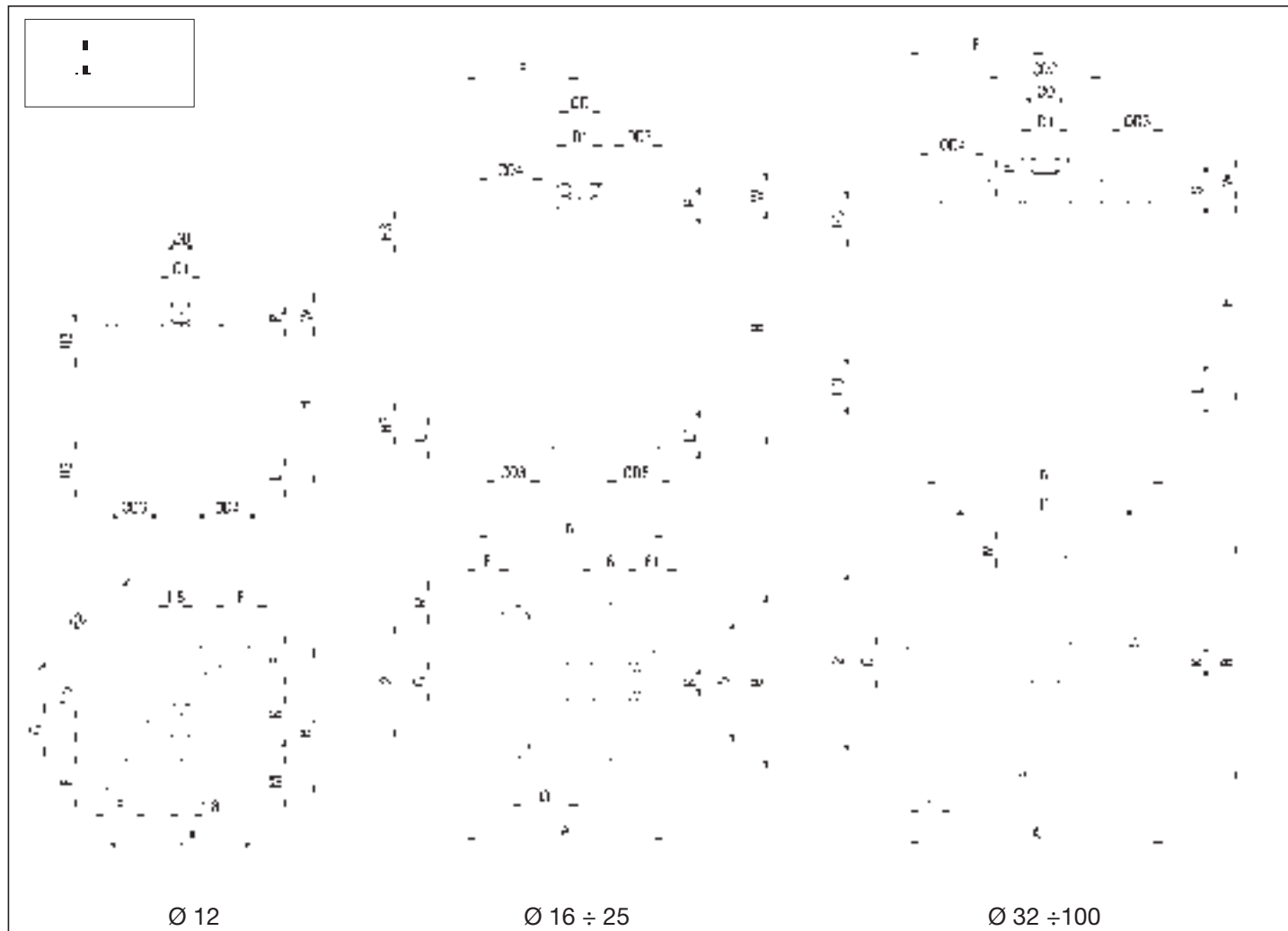

DIMENSIONS AND WEIGHTS

Ø	A	B	D	D1	D2	D3	D4	D7	D8	E	F	F1	G	H3	I1	I2	I3	I5	I6	K	L	L1	M	N	P	S	W	WEIGHT (g)	INCR. (g) x10 mm
12	25	25	6	M3	-	3,7	5,6	-	-	-	4,7	-	M5	5,5	-	-	-	-	-	5	3,5	-	4,7	-	6	-	3,5	33,5	11,5
16	34	30	8	M4	-	4,7	7,5	3,7	5,6	19	7	5	M5	8	-	18	12	20	10	6	4,6	3,5	4	32	8	-	4,5	74	16,5
20	40	36	10	M5	-	5,8	9	5,8	9	22	7	5,2	M5	8	-	20	15	25,5	12,7	8	5,7	5,7	5,7	38,5	10	-	5	106	24,5
25	44,5	40	10	M5	-	5,8	9	5,8	9	24,5	9	6	G1/8	10,5	-	26	15,5	28	14	8	5,7	5,7	4,5	42	10	-	5,5	145	32
32	51	46	12	M6	24,5	5,8	9	-	-	27	9	-	G1/8	11,5	36	32	-	-	-	10	5,7	-	4	48	12	5	11	172	36
40	58	55	12	M6	28	5,8	9	-	-	30,5	9,5	-	G1/8	11	42	42	-	-	-	10	5,7	-	4	55	12	6	12,5	225	40
50	70	65	16	M8	34	6,8	11	-	-	37,5	12,5	-	G1/8	11,5	50	50	-	-	-	13	6,8	-	4	65	12	6	13,5	359	63
63	86	80	16	M8	38,5	9	14	-	-	46	15	-	G1/8	11	62	62	-	-	-	13	8,8	-	5	80	14	7	15	552	70
80	105	100	20	M10	44	9	14	-	-	55	14	-	G1/4	14	82	82	-	-	-	17	9	-	6	100	15	8	18	1072	105
100	131	124	25	M12	56	11	17,2	-	-	69	17,5	-	G1/4	16	103	103	-	-	-	22	11	-	7,5	124	20	10	20,5	1920	160

H DIMENSION

Ø	STROKE (mm)														
	5	10	15	20	25	30	40	50	60	80	100	125	160	200	250
12	32	37	42	47	52	57	-	-	-	-	-	-	-	-	-
16	37	42	47	52	63	68	78	88	98	118	138	-	-	-	-
20	37	42	47	52	63	68	78	88	98	118	138	163	-	-	-
25	43,5	48,5	53,5	58,5	64,5	69,5	79,5	89,5	99,5	119,5	139,5	164,5	-	-	-
32	44,5	49,5	54,5	59,5	64,5	69,5	79,5	89,5	99,5	119,5	139,5	164,5	199,5	-	-
40	44,5	49,5	54,5	59,5	64,5	69,5	79,5	89,5	99,5	119,5	139,5	164,5	199,5	-	-
50	-	49,5	54,5	59,5	64,5	69,5	79,5	89,5	99,5	119,5	139,5	164,5	199,5	239,5	-
63	-	52	57	62	67	72	82	92	102	122	142	167	202	242	-
80	-	56	61	66	71	76	86	96	106	126	146	171	206	246	296
100	-	66	71	76	81	86	96	106	116	136	156	181	216	256	306

SINGLE ACTING, EXTENDED ROD AND SINGLE ACTING MAGNETIC, EXTENDED ROD

1

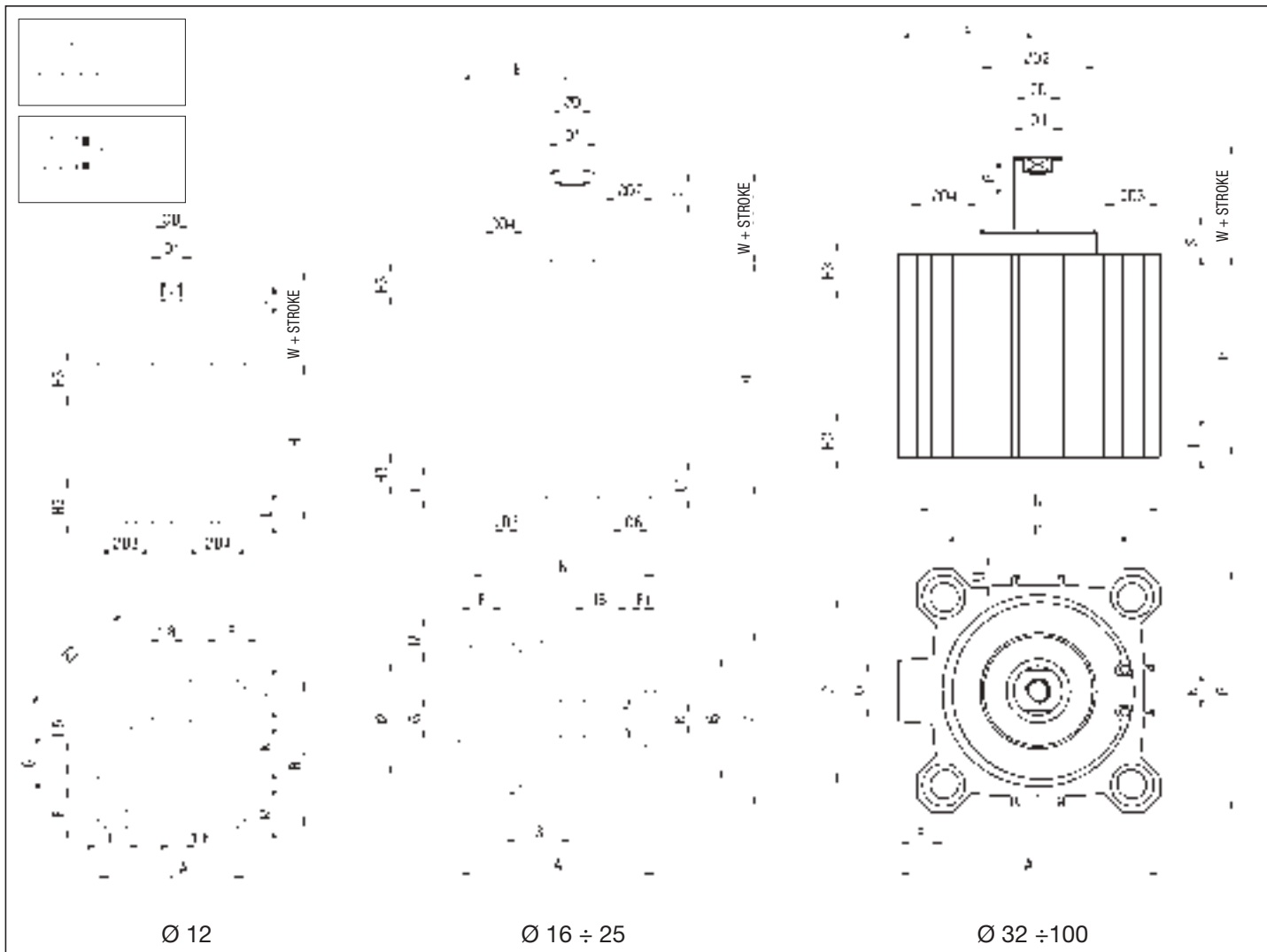

DIMENSIONS AND WEIGHTS

Ø	A	B	D	D1	D2	D3	D4	D7	D8	E	F	F1	G	H3	I1	I2	I3	I5	I6	K	L	L1	M	N	P	S	W	WEIGHT (g)	INCR. (g) x10 mm
12	25	25	6	M3	-	3,7	5,6	-	-	-	4,7	-	M5	5,5	-	-	-	-	-	5	3,5	-	4,7	-	6	-	3,5	33,5	11,5
16	34	30	8	M4	-	4,7	7,5	3,7	5,6	19	7	5	M5	8	-	18	12	20	10	6	4,6	3,5	4	32	8	-	4,5	74	16,5
20	40	36	10	M5	-	5,8	9	5,8	9	22	7	5,2	M5	8	-	20	15	25,5	12,7	8	5,7	5,7	5,7	38,5	10	-	4,5	106	24,5
25	44,5	40	10	M5	-	5,8	9	5,8	9	24,5	9	6	G 1/8	10,5	-	26	15,5	28	14	8	5,7	5,7	4,5	42	10	-	5,5	145	32
32	51	46	12	M6	24,5	5,8	9	-	-	27	9	-	G 1/8	11,5	36	32	-	-	-	10	5,7	-	4	48	12	5	11	172	36
40	58	55	12	M6	28	5,8	9	-	-	30,5	9,5	-	G 1/8	11	42	42	-	-	-	10	5,7	-	4	55	12	6	12,5	225	40
50	70	65	16	M8	34	6,8	11	-	-	37,5	12,5	-	G 1/8	11,5	50	50	-	-	-	13	6,8	-	4	65	12	6	13,5	359	63
63	86	80	16	M8	38,5	9	14	-	-	46	15	-	G 1/8	11	62	62	-	-	-	13	8,8	-	5	80	14	8	15	552	70

H DIMENSION

Ø	STROKE (mm)						
		5	10	15	20	25	30
12	-	22	27	-	-	-	-
-	12 magn	32	37	-	-	-	-
16	16 magn	37	42	47	-	-	-
20	20 magn	37	42	47	63	68	-
25	25 magn	43,5	48,5	53,5	64,5	69,5	-
32	32 magn	44,5	49,5	54,5	64,5	69,5	79,5
40	40 magn	-	49,5	54,5	59,5	64,5	69,5
50	50 magn	-	49,5	54,5	59,5	64,5	69,5
63	63 magn	-	52	57	62	67	72

DOUBLE ACTING, THROUGH ROD AND DOUBLE ACTING MAGNETIC, THROUGH ROD

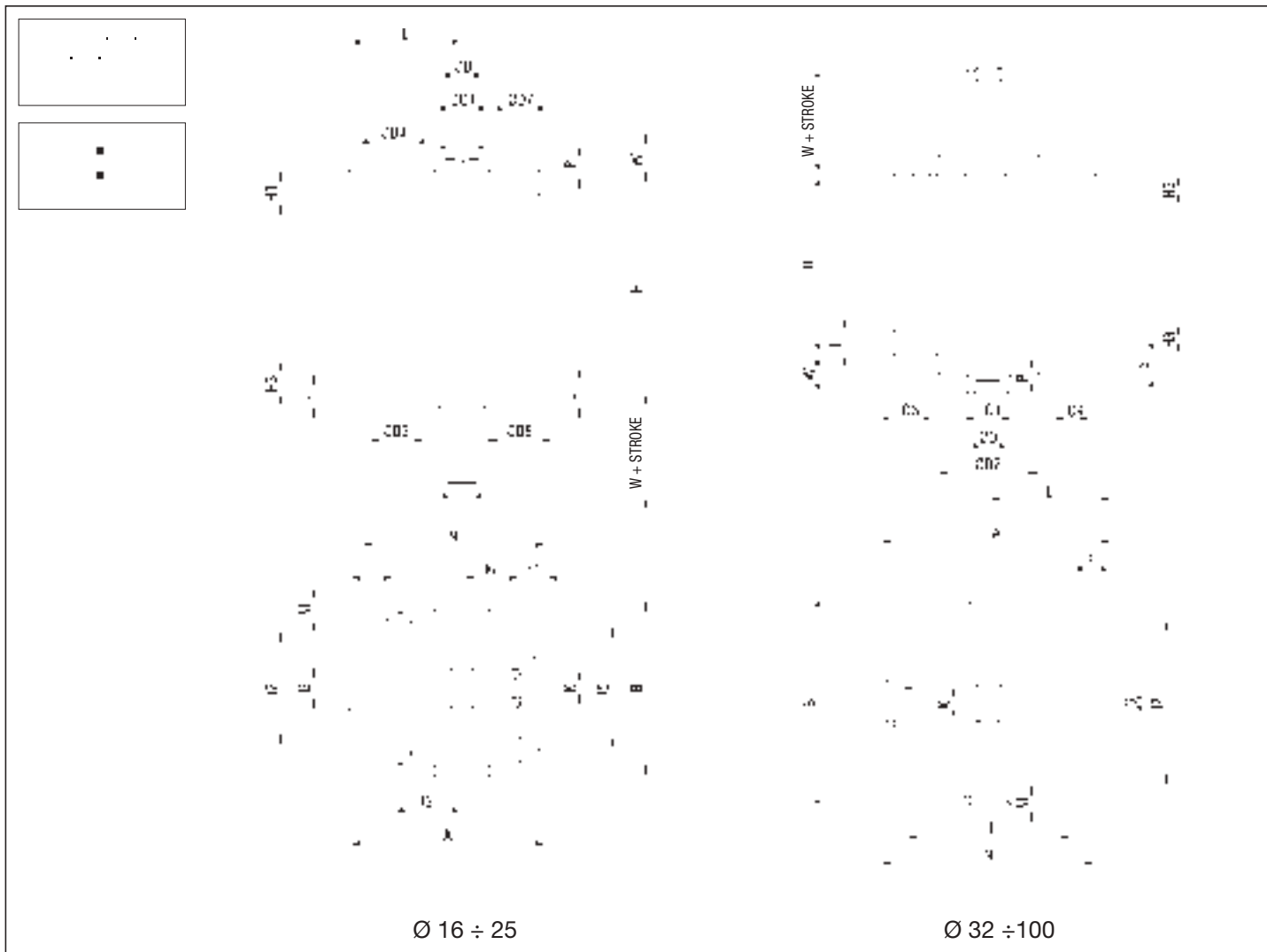

DIMENSIONS AND WEIGHTS

Ø	A	B	D	D1	D2	D3	D4	D7	D8	E	F	F1	G	H3	I1	I2	I3	I5	I6	K	L	L1	M	N	P	S	W	WEIGHT (g)	INCR. (g) x 10mm
16	34	30	8	M4	-	4,7	7,5	3,7	5,6	19	7	5	M5	8	-	18	12	20	10	6	4,6	3,5	4	32	8	-	4,5	130	19
20	40	36	10	M5	-	5,8	9	5,8	9	22	7	5,2	M5	8	-	20	15	25,5	12,7	8	5,7	5,7	5,7	38,5	10	-	4,5	150	28
25	44,5	40	10	M5	-	5,8	9	5,8	9	24,5	9	6	G 1/8	10,5	-	26	15,5	28	14	8	5,7	5,7	4,5	42	10	-	5,5	185	35,5
32	51	46	12	M6	24,5	5,8	9	-	-	27	9	-	G 1/8	11,5	36	32	-	-	-	10	5,7	-	4	48	12	5	11	282	39,5
40	58	55	12	M6	28	5,8	9	-	-	30,5	9,5	-	G 1/8	11	42	42	-	-	-	10	5,7	-	4	55	12	6	12,5	366	43,5
50	70	65	16	M8	34	6,8	11	-	-	37,5	12,5	-	G 1/8	11,5	50	50	-	-	-	13	6,8	-	4	65	12	6	13,5	521	68
63	86	80	16	M8	38,5	9	14	-	-	46	15	-	G 1/8	11	62	62	-	-	-	13	8,8	-	5	80	14	8	15	717	75
80	105	100	20	M10	44	9	14	-	-	55	14	-	G 1/4	14	82	82	-	-	-	17	9	-	6	100	15	10	18	1434	114
100	131	124	25	M12	56	11	17,2	-	-	69	17,5	-	G 1/4	16	103	103	-	-	-	22	11	-	7,5	124	20	10,5	20,5	2435	174

H DIMENSION

Ø	STROKE (mm)														
	5	10	15	20	25	30	40	50	60	80	100	125	160	200	250
16	37	42	47	52	63	68	78	88	98	118	138	-	-	-	-
20	37	42	47	52	63	68	78	88	98	118	138	163	-	-	-
25	43,5	48,5	53,5	58,5	64,5	69,5	79,5	89,5	99,5	119,5	139,5	164,5	-	-	-
32	44,5	49,5	54,5	59,5	64,5	69,5	79,5	89,5	99,5	119,5	139,5	164,5	199,5	-	-
40	44,5	49,5	54,5	59,5	64,5	69,5	79,5	89,5	99,5	119,5	139,5	164,5	199,5	-	-
50	-	49,5	54,5	59,5	64,5	69,5	79,5	89,5	99,5	119,5	139,5	164,5	199,5	239,5	-
63	-	52	57	62	67	72	82	92	102	122	142	167	202	242	-
80	-	56	61	66	71	76	86	96	106	126	146	171	206	246	296
100	-	66	71	76	81	86	96	106	116	136	156	181	216	256	306

NON ROTATING DOUBLE ACTING AND NON ROTATING DOUBLE ACTING MAGNETIC

1

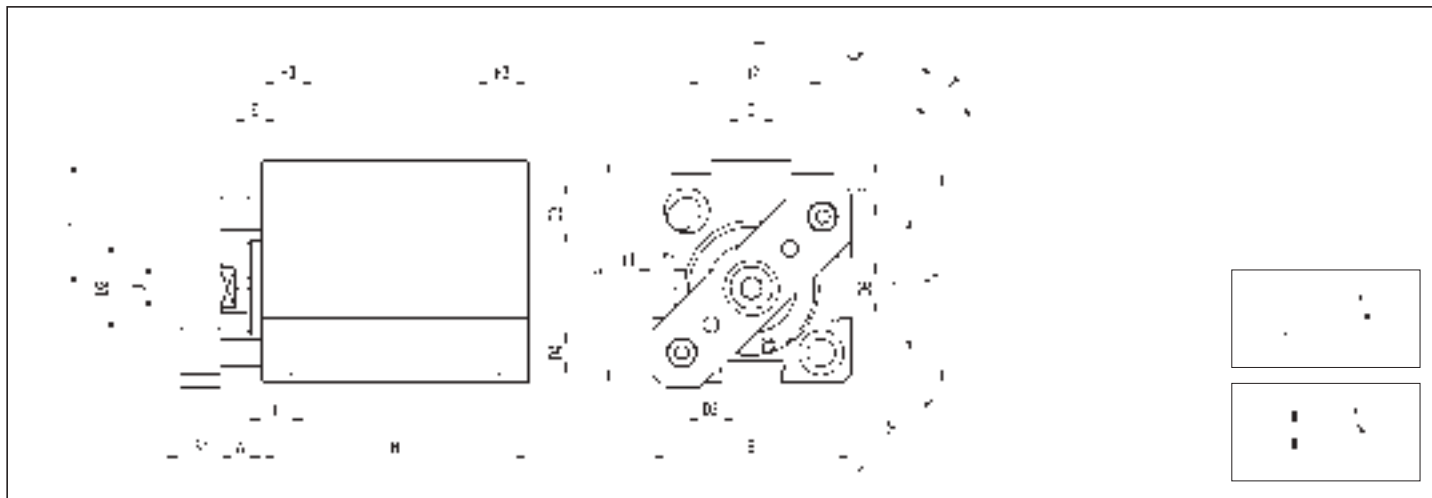

DIMENSIONS AND WEIGHTS

Ø	A	B	α	D	D2	D3	D4	D5	D6	E	F	G	H3	I1	I2	I4	L	M	N	S	S1	T	W	WEIGHT (g)	INCR. (g) x10 mm
20	40	36	45°	10	-	5,8	9,2	M4	11	22	9,3	M5	8	25,5	25,5	20	5,7	5,7	38,5	-	8	15	4,5	150	28
25	44,5	40	45°	10	-	5,8	9,2	M4	11	24,5	10,5	G 1/8	11	28	28	22	5,7	4,5	42	-	8	15	5,5	185	35,5
32	51	46	41,5°	12	24,5	5,8	9,2	M5	17	27	9	G 1/8	11,5	36	32	28	5,7	4	48	5	10	20	11	282	39,5
40	58	55	45°	12	28	5,8	9,2	M5	17	30,5	9,5	G 1/8	11,5	42	42	33	5,7	4	55	6	10	20	12,5	366	43,5
50	70	65	45°	16	34	6,8	11	M6	22	37,5	12,5	G 1/8	11,5	50	50	42	6,8	4	65	6	12	30	13,5	521	68
63	86	80	45°	16	38,5	9	14	M6	22	46	15	G 1/8	12	62	62	50	8,8	5	80	8	12	30	15	717	75
80	105	100	45°	20	44	9	14	M8	28	55	14	G 1/4	14	82	82	65	9	6	100	10	14	50	18	1434	114
100	131	124	45°	25	56	11	17,2	M10	30	69	17,5	G 1/4	16	103	103	80	11	7,5	124	10,5	14	50	20,5	2435	174

H DIMENSION

Ø	STROKE (mm)													
	5	10	15	20	25	30	40	50	60	80	100	125	160	
20	37	42	47	52	63	68	78	88	98	118	138	-	-	
25	43,5	48,5	53,5	58,5	64,5	69,5	79,5	89,5	99,5	119,5	139,5	-	-	
32	44,5	49,5	54,5	59,5	64,5	69,5	79,5	89,5	99,5	119,5	139,5	-	-	
40	44,5	49,5	54,5	59,5	64,5	69,5	79,5	89,5	99,5	119,5	139,5	-	-	
50	-	49,5	54,5	59,5	64,5	69,5	79,5	89,5	99,5	119,5	139,5	164,5	-	
63	-	52	57	62	67	72	82	92	102	122	142	167	202	
80	-	56	61	66	71	76	86	96	106	126	146	171	206	
100	-	66	71	76	81	86	96	106	116	136	156	181	216	

FEET (pair) - ALUMINIUM - B/PB Ø

Ø	A2	B2	C	D9	E1	F2	I6
16	5	10	10	3,5	17	5	30
20	5	10	10	3,5	18	5	40
25	6	12	12	5,5	20	7,5	45
32	6	12	12	5,5	24	5	50
40	6	12	12	5,5	27,5	5	60
50	7,5	15	15	6,5	32,5	5	70
63	7,5	15	15	8,5	40	7,5	85
80	10	20	20	8,5	50	20	60
100	10	20	20	10,5	62	22	80

Ø	L2	M1	N1	R	WEIGHT (g)
16	H+10	2,4	40	M3	10
20	H+10	4	50	M5	10,1
25	H+12	4	60	M5	20,4
32	H+12	4	60	M5	20,4
40	H+12	4	70	M5	24,7
50	H+15	5	80	M6	44,7
63	H+15	6,5	100	M8	53
80	H+20	6,5	100	M8	99
100	H+20	8	124	M10	120

*DIMENSION "H" IS OBTAINABLE FROM THE TABLES OF THE SINGLE VERSION

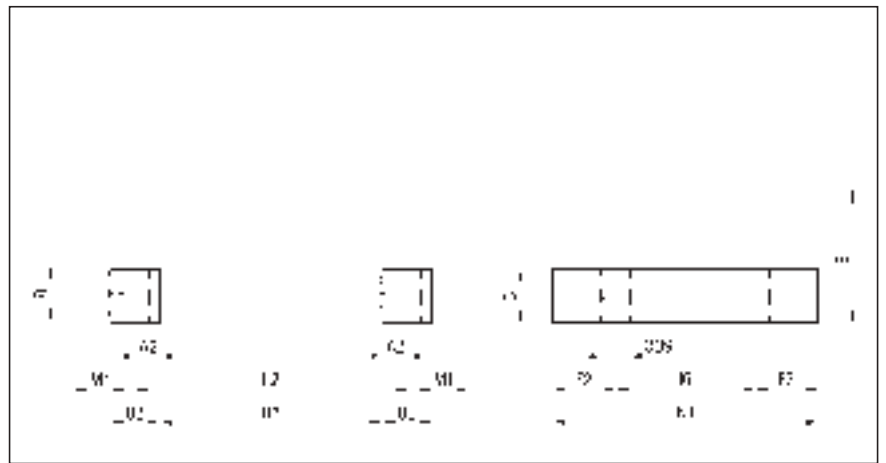
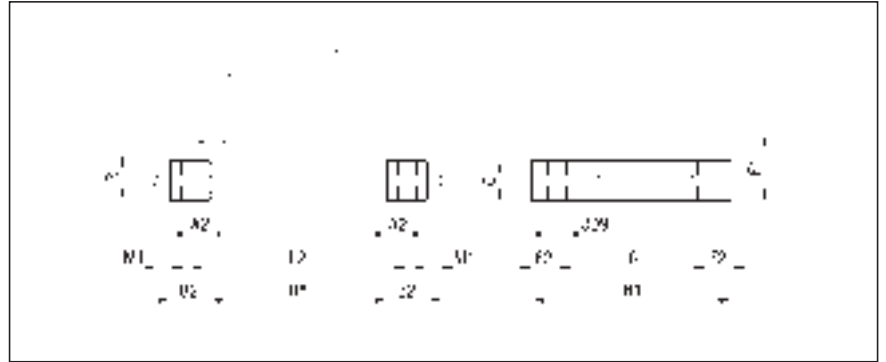

MALE HINGE MOUNTING

Ø	A1	B	E2 H8	H5	Z	B1
16	8	6	6	12	7	14
20	10	8	8	16	9	18
25	10	8	8	16	9	18
32	13	10	10	20	14	23
40	15	12	12	24	16	27
50	15	12	12	24	17	27
63	19	16	16	32	22	35
80	19	16	16	32	22	35
100	23	20	20	40	26	43

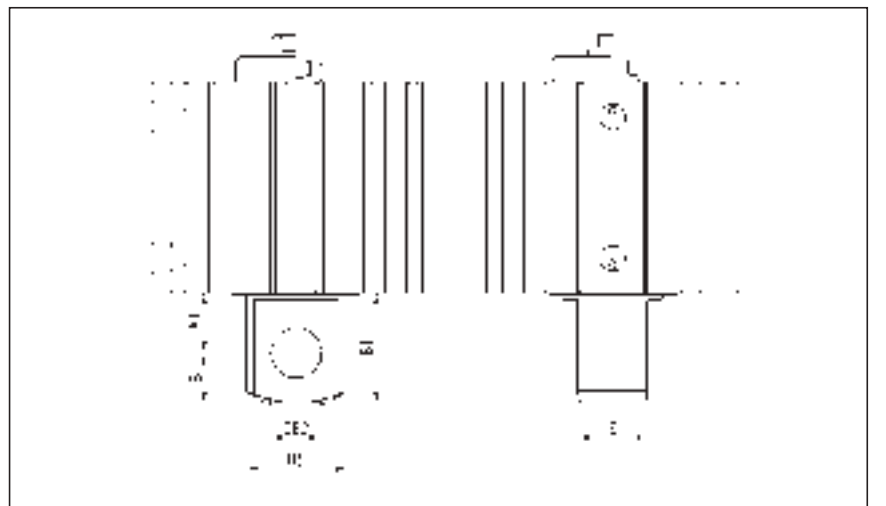

ROD NIPPLE WITH THREAD TO ISO STANDARD - STEEL - NB Ø

Ø	D	D1	A	B	C	WEIGHT (g)
12	M6x1	M3	16	6,5	22,5	3
16	M6x1	M4	15	8	23	3,2
20-25	M8x1,25	M5	20	10	30	7,2
32-40	M10x1,25	M6	22	12	34	13,1
50-63	M12x1,25	M8	24	14	38	23
G50-63	M16x1,5	M8	32	14	46	47,6
80	M16x1,5	M10	32	15	47	50,5
100	M20x1,5	M12	40	20	60	101

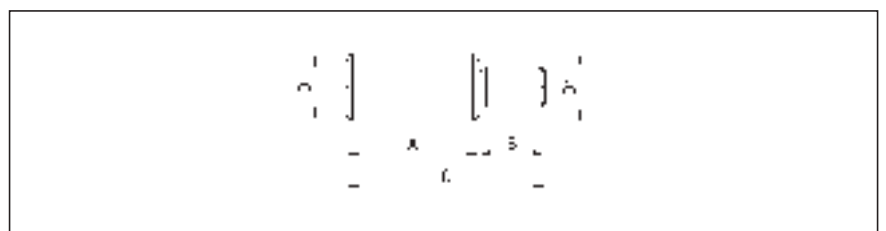

DESCRIPTION

Compact guided cylinders series "BG" have reduced dimensions and high precision movement. These cylinders assure great strenght to transversal forces thanks to stout bars guided on bushings or sleeves. Cylinders series "BG" are double acting and they have the magnetic piston type and the steel plate as standard, so they can be supplied with magnetic sensors.

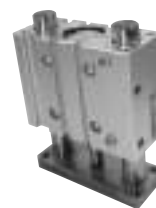

TECHNICAL DATA

Operating pressure	1 ÷ 10 bar
Working temperature	0 ÷ +80 °C (-20 °C with dry air)
Fluid	Filtered, unlubricated, continuous lubricated or dry compressed air
Bore	Ø 16, 20, 25, 32, 40, 50, 63
Port size	Ø 16 = M 5 Ø 20 ÷ 40 = G 1/8 Ø 50 - 63 = G 1/4
Standard strokes (mm)*	Ø 16 = 10, 20, 30, 40, 50, 75, 100 Ø 20 = 20, 30, 40, 50, 75, 100, 125, 150, 175, 200 Ø 25 = 20, 25, 30, 40, 50, 75, 100, 125, 150, 175, 200 Ø 32 ÷ 63 = 25, 50, 75, 100, 125, 150, 175, 200

Cylinders with intermediate strokes have the same dimensions of the ones referring to the right higher standard stroke; e.g.: Ø32, 45 mm stroke cylinder has the same dimensions of the cylinder with 50 mm stroke.

ORDER KEY

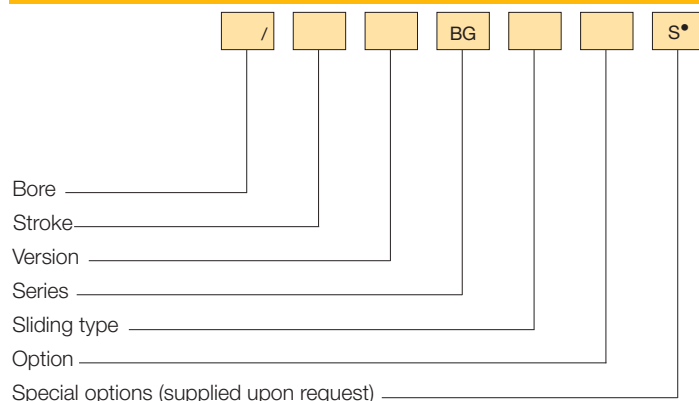

• See Chapter 1 on page 1.1.

MATERIALS

End caps	Anodized aluminium alloy
Corpo	Anodized aluminium alloy
Piston rod	Ø16 ÷ 25 AISI 303 stainless steel Ø32 ÷ 63 C45 chromium-plated steel
Piston	Aluminium alloy with magnet
Guide bars	C45 chromium-plated steel (bushings sliding type) Hardened steel (recirculating ball bearing sleeves sliding type)
Plate	Nickel-plated steel
Bushings	Self-lubricating sintered bronze with wiper ring (No.2 pcs. for strokes 20 ÷ 50 mm; No.4 pcs. for strokes 75 ÷ 200 mm)
Sleeves	Recirculating ball bearings with wiper ring (No.2 pcs. for strokes 20 ÷ 50 mm; No.4 pcs. for strokes 75 ÷ 200 mm)
Seals	Polyurethane

VERSION

D Double acting

SLIDING TYPE

B On bushing

M With sleeves

OPTION

Single steel plate

D Double steel plate

ORDER EXAMPLES

Cylinder Ø 50, double acting, 50 mm stroke, with sleeves, double steel plate:
50/50 DBGMD

SPARE PARTS

SEALS KIT

Polyurethane (Bushing sliding type)

Ø/SG/BGB

Polyurethane (Recirculating ball bearing sleeves sliding type)

Ø/SG/BGM

TECHNICAL DATA

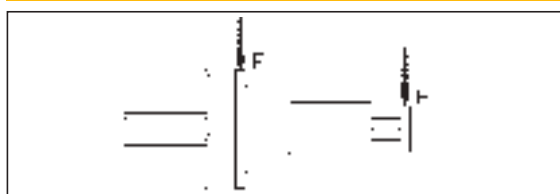

MAXIMUM PERMISSIBLE TRANSVERSE FORCE "F" (N)

Ø	Sliding type	STROKE (mm)								
		10	20	25	30	40	50	75	100	
16	B	41	32	-	26	23	20	27	22	
	M	44	34	-	27	23	21	27	22	
20	B	-	53	-	45	38	34	52	42	
	M	-	62	-	50	42	36	53	44	
25	B	-	93	-	78	68	60	81	67	
	M	-	94	-	79	68	60	59	51	
32	B	-	-	168	-	-	131	163	138	
	M	-	-	84	-	-	58	270	213	
40	B	-	-	168	-	-	131	163	138	
	M	-	-	92	-	-	64	270	213	
50	B	-	-	240	-	-	189	243	208	
	M	-	-	117	-	-	81	370	312	
63	B	-	-	250	-	-	190	265	227	
	M	-	-	117	-	-	81	370	312	

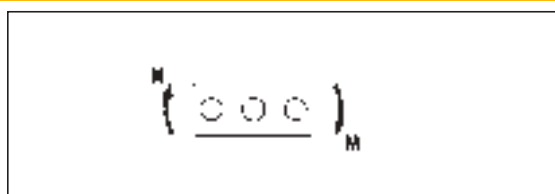

MAXIMUM PERMISSIBLE TORQUE "M" (Nm)

Ø	Sliding type	STROKE (mm)								
		10	20	25	30	40	50	75	100	
16	B	0,65	0,51	-	0,42	0,36	0,32	-	-	
	M	0,83	0,65	-	0,52	0,44	0,40	-	-	
20	B	-	0,99	-	0,84	0,71	0,64	0,97	0,78	
	M	-	1,20	-	0,96	0,81	0,69	1,02	0,85	
25	B	-	1,98	-	1,67	1,45	1,28	1,73	1,43	
	M	-	2,00	-	1,69	1,45	1,28	1,26	1,09	
32	B	-	-	4,10	-	-	3,19	3,97	3,36	
	M	-	-	2,04	-	-	1,41	6,58	5,19	
40	B	-	-	4,51	-	-	3,51	4,38	3,70	
	M	-	-	2,47	-	-	1,72	7,25	5,72	
50	B	-	-	6,60	-	-	5,19	6,68	5,72	
	M	-	-	3,22	-	-	2,22	10,17	8,58	
63	B	-	-	6,60	-	-	5,19	6,68	5,72	
	M	-	-	3,22	-	-	2,22	10,17	8,58	

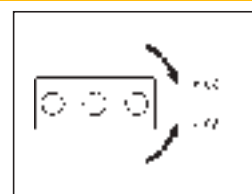

ANTI-ROLL ACCURACY α

Ø	Sliding type	
	B	M
16	±0,08°	±0,10°
20	±0,07°	±0,09°
25	±0,07°	±0,09°
32	±0,06°	±0,08°
40	±0,06°	±0,08°
50	±0,05°	±0,06°
63	±0,05°	±0,06°

B - Bushing
M - Sleeves

COMPACT GUIDED CYLINDER

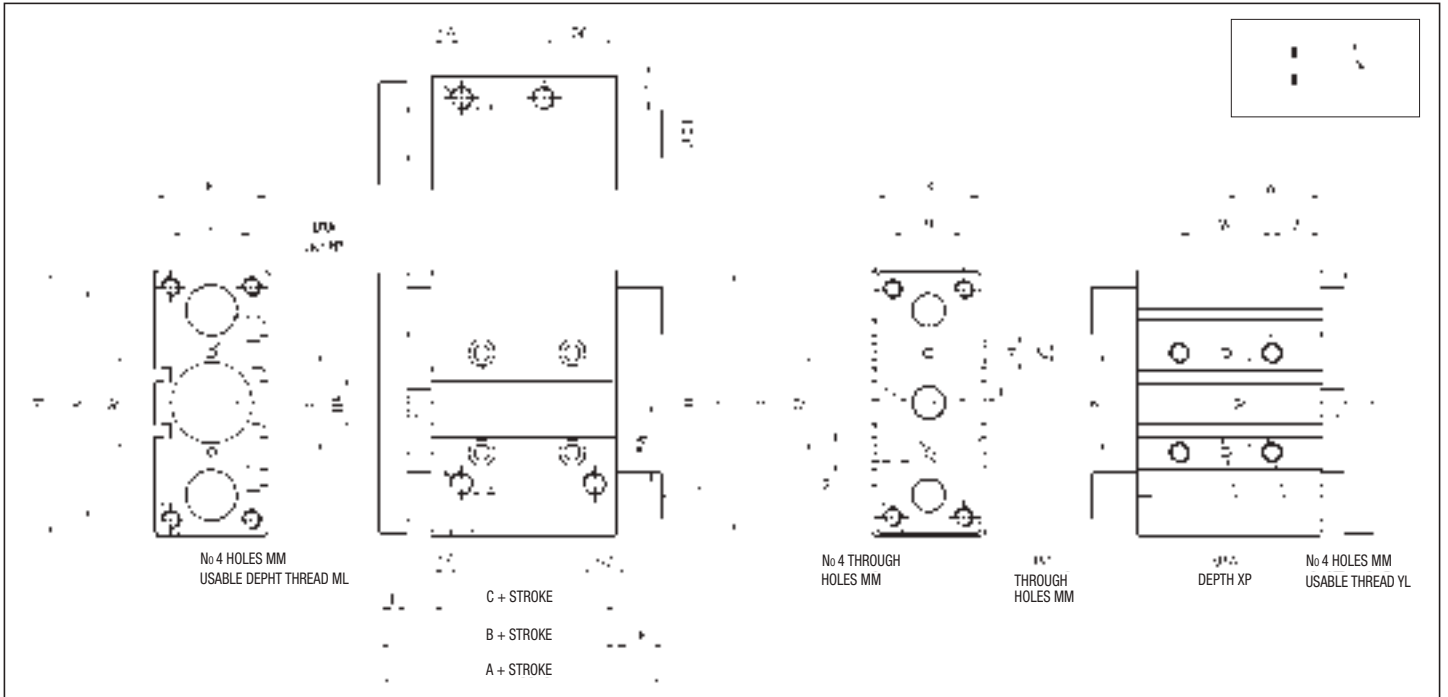

DIMENSIONS AND WEIGHTS BASIC CYLINDER

Ø	B	C	DA	F	GA	GB	GC	H	J	K	L	MM	ML	NN	P	PW	Q	R	S	T	U	V	X	YY	YL	YE	YH	YI	Z	XF	XA	XP	XB
16	46	33	8	8	11	8	18	64	5	30	22	M5	12	M5	M5	19	16	54	25	62	46	56	24	M5	10	8	4,5	4,3	5	24	3	6	3,5
20	5	37	10	10	10,5	8,5	24,5	83	6,5	36	24	M5	13	M5	G1/8	25	18	70	30	81	54	72	28	M6	12	9,5	5,5	5,6	17	28	3	6	3,5
25	53,5	37,5	10	10	11,5	9	25	93	7,5	42	30	M6	15	M6	G1/8	28,5	26	78	38	91	64	82	34	M6	12	9,5	5,5	5,6	17	34	4	6	4,5
32	59,5	37,5	12	12	12,5	9	30,5	112	9	48	34	M8	20	M8	G1/8	34	30	96	44	110	78	98	42	M8	16	11	7,5	6,6	21	42	4	6	4,5
40	66	44	12	12	14	10	31	120	9	54	40	M8	20	M8	G1/8	38	30	104	44	118	86	106	50	M8	16	11	7,5	6,6	22	50	4	6	4,5
50	72	44	16	16	14	11	35	148	9,5	64	46	M10	22	M10	G1/4	47	40	130	60	146	110	130	66	M10	20	14	9	8,6	24	66	5	8	6
63	77	49	16	16	16,5	13,5	35	162	11	78	58	M10	22	M10	G1/4	55	50	130	70	158	124	142	80	M10	20	14	9	8,6	24	80	5	8	6

DIMENSIONS: W - W1 - A - E (VERSION WITH SLEEVES)

Ø stroke	W					W1					A			E			DB		
	10÷30	40÷100	125÷200	250÷300		10÷30	40÷100	125÷200	250÷300		10÷30	40÷100	125÷250	10÷30	40÷100	125÷250			
16	24	44	110	200		17	27	60	105		46	66	95	0	20	49	8		
Ø stroke	W					W1					A			E			DB		
	20÷30	40÷100	125÷200	250÷300	350÷400	20÷30	40÷100	125÷200	250÷300	350÷400	20÷30	40÷200	250÷400	20÷30	40÷200	250÷400			
20	24	44	120	200	300	29	39	77	117	167	53	85,5	122	0	32,5	69	12		
25	24	44	120	200	300	29	39	77	117	167	53,5	86	122	0	32,5	68,5	12		
Ø stroke	W					W1					A			E			DB		
	25	50÷100	125÷200	250÷300	350÷400	25	50÷100	125÷200	250÷300	350÷400	25	50	75÷200	250÷400	25	50		75÷200	250÷400
32	24	48	124	200	300	33	45	83	121	171	97	97	107	140	37,5	37,5	47,5	85,5	20
40	24	48	124	200	300	34	46	84	122	172	97	97	107	140	31	31	41	79	20
50	24	48	124	200	300	36	48	86	124	174	106,5	114	118	161	34,5	42	46	89	25
63	28	52	128	200	300	38	50	88	124	174	106,5	114	118	161	29,5	37	41	84	25

DIMENSIONS: A - E (VERSIONS WITH BUSHING)

Ø stroke	A			E			DB
	10÷50	75÷100	125÷200	10÷50	75÷100	125÷250	
16	46	64,5	95	0	18,5	49	10
Ø stroke	A			E			DB
	20÷50	75÷200	250÷400	20÷50	75÷200	250÷400	
20	53	84,5	122	0	31,5	69	12
25	53,5	85	122	0	31,5	68,5	16
Ø stroke	A			E			DB
	20÷50	75÷200	250÷400	20÷50	75÷200	250÷400	
32	97	107	140	37,5	47,5	80,5	20
40	97	107	140	31	41	79	20
50	106,5	118	161	34,5	46	89	25
63	106,5	118	161	29,5	41	84	25

1

DOUBLE STEEL PLATE COMPACT GUIDED CYLINDER

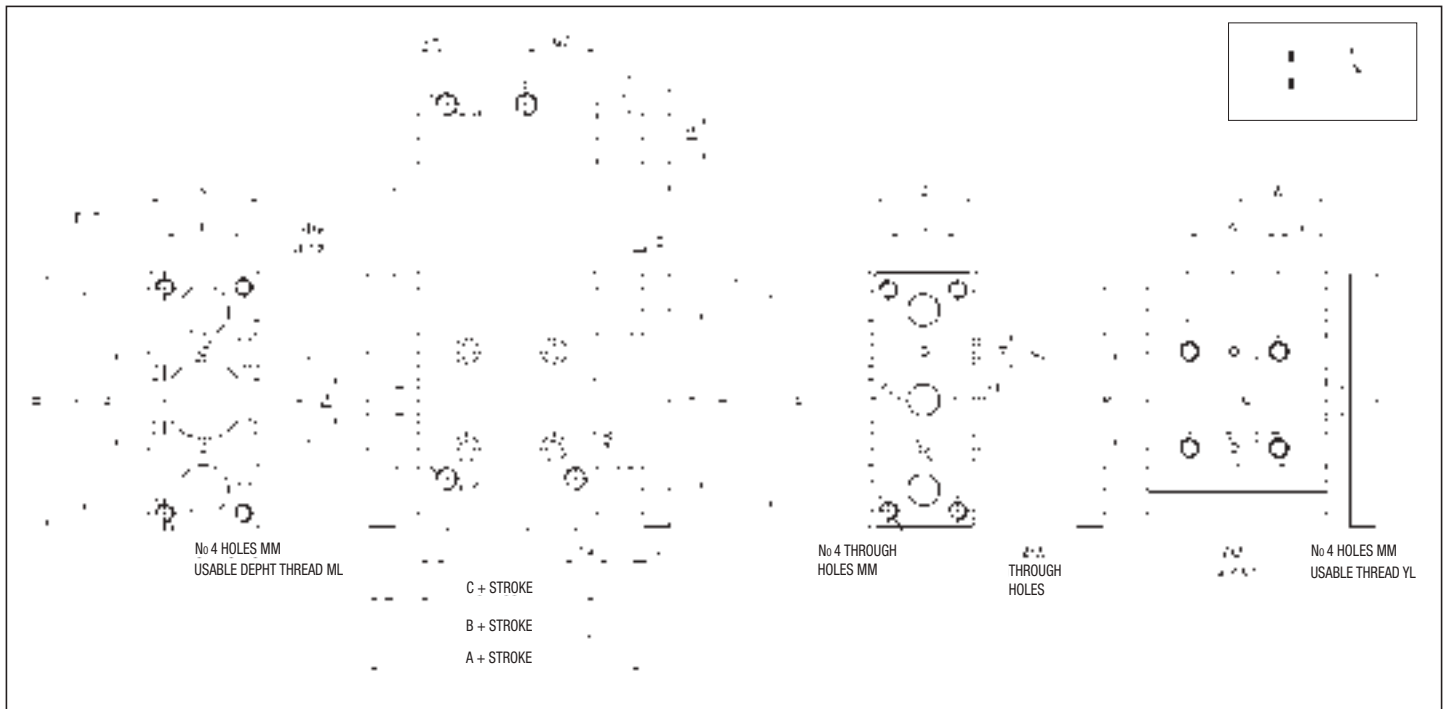

DIMENSIONS AND WEIGHTS BASIC CYLINDER

Ø	A	B	C	DA	F	GA	GB	GC	H	J	K	L	MM	ML	NN	P	PW	Q	R	S	T	U	V	X	XF	XA	XP	YY	YL	YE	YH	YI	Z	XF	XA	XP	XB
16	59	46	33	8	8	11	8	18	64	5	30	22	M5	12	M5	M5	19	16	54	25	62	46	56	24	24	3	6	M5	10	8	4,5	4,3	5	24	3	6	3,5
20	69	5	37	10	10	10,5	8,5	24,5	83	6,5	36	24	M5	13	M5	G1/8	25	18	70	30	81	54	72	28	28	3	6	M6	12	9,5	5,5	5,6	17	28	3	6	3,5
25	69,5	53,5	37,5	10	10	11,5	9	25	93	7,5	42	30	M6	15	M6	G1/8	28,5	26	78	38	91	64	82	34	34	4	6	M6	12	9,5	5,5	5,6	17	34	4	6	4,5
32	81,5	59,5	37,5	12	12	12,5	9	30,5	112	9	48	34	M8	20	M8	G1/8	34	30	96	44	110	78	98	42	42	4	6	M8	16	11	7,5	6,6	21	42	4	6	4,5
40	88	66	44	12	12	14	10	31	120	9	54	40	M8	20	M8	G1/8	38	30	104	44	118	86	106	50	50	4	6	M8	16	11	7,5	6,6	22	50	4	6	4,5
50	100	72	44	16	16	14	11	35	148	9,5	64	46	M10	22	M10	G1/4	47	40	130	60	146	110	130	66	66	5	8	M10	20	14	9	8,6	24	66	5	8	6
63	105	77	49	16	16	16,5	13,5	35	162	11	78	58	M10	22	M10	G1/4	55	50	130	70	158	124	142	80	80	5	8	M10	20	14	9	8,6	24	80	5	8	6

DIMENSIONS: W - W1 (VERSION WITH SLEEVES)

Ø stroke	W			W1			
	10÷30	40÷100		10÷30	40÷100		
16	24	44		17	27		
Ø stroke	W			W1			
	20÷30	40÷100	125÷200	20÷30	40÷100	125÷200	
	20	24	44	120	29	39	77
25	24	44	120	29	39	77	
Ø stroke	W			W1			
	25	50÷100	125÷200	25	50÷100	125÷200	
	32	24	48	124	33	45	83
	40	24	48	124	34	46	84
50	24	48	124	36	48	86	
63	28	52	128	38	50	88	

DIMENSION: DB

Ø	DB Bushing	DB Sleeves
16	10	8
20	12	12
25	16	12
32	20	20
40	20	20
50	25	25
63	25	25

SLOTS FIXING PLATE - STEEL - BG/PF Ø

Ø	A	B	C	D	CH	WEIGHT (g)
16	7	10	M4	3,5	1,5	2
20 - 25	8	15	M5	4	2	3,5
32 - 40	10	20	M6	5	2,5	7,5
50 - 63	13	25	M8	7	3	17

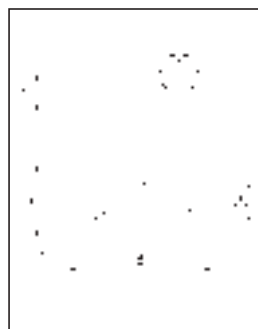

FIXING EXAMPLE



DESCRIPTION

Twin rod cylinders series "CPA", and their fixing accessories, act as devices against rotation in the presence of torques. They have been designed to be interchangeable with cylinders that comply with ISO 15552 standard (series "X" and "XT") and so they can be used with those standardized rear mountings. The cylinders series "CPA" are supplied cushioned at both ends and with magnetic piston type as standard and, upon request, they comply with ATEX directive, 2GD category.



1

TECHNICAL DATA

Operating pressure	1 ÷ 10 bar
Working temperature	0 ÷ +80 °C (-20 °C with dry air)
Fluid	Filtered, unlubricated, continuous lubricated or dry compressed air
Versions	Double acting, Through rod to ISO
Bore	Ø 32, 40, 50, 63, 80, 100
Port size	Ø 32 = G 1/8 Ø 40 - 50 = G 1/4 Ø 63 - 80 = G 3/8 Ø 100 = G 1/2
Standard strokes (mm)	25, 50, 75, 80, 100, 125, 150, 160, 175, 200, 250, 300, 320, 350, 400, 500
Decelerators length	Ø 32 40 50 63 80 100 mm 25 25 25 30 35 35
Maximum strokes (mm)	Ø 32 - 40 = 200; Ø 50 - 63 = 350; Ø 80 - 100 = 500

*Cylinders, with strokes shorter than the decelerators lengths, are NOT cushioned as standard.

MATERIALS

End caps	Anodized aluminium alloy
Cylinder barrel	Extruded profile, 20µm anodized aluminium alloy
Tie rods and nuts	Steel
Flange	Anodized aluminium alloy
Piston rod	C45 chromium-plated steel AISI 303 rolled stainless steel
Piston rod bearing	Bronze, sintered, self-lubricating
Decelerators ogives	Brass/aluminium alloy
Piston	Aluminium alloy, Dering with magnet
Seals	Polyurethane

ORDER KEY

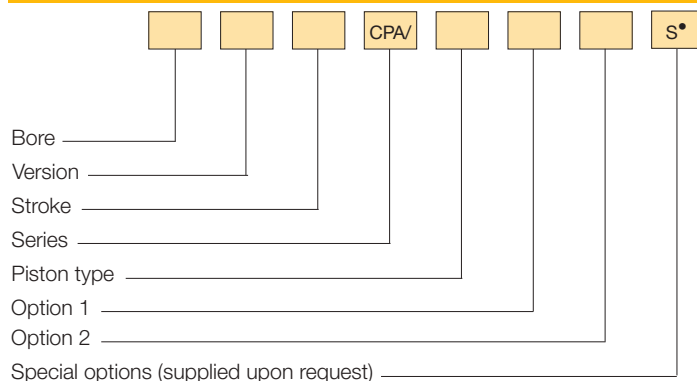

• See Chapter 1 on page 1.1.

VERSION

/ Double acting **RA** Through rod to ISO

PISTON TYPE

M Magnetic

OPTION 1

1 Stainless steel piston rods

OPTION 2

/EX Consistent with the ATEX directive II 2GD c T5 T100°C -20°C<Ta<80°C

SPARE PARTS

SEALS KIT

Polyurethane
Through rod to ISO, polyurethane

Ø/SG/CPA/M
Ø/SG/RA/CPA/M

TECHNICAL DATA

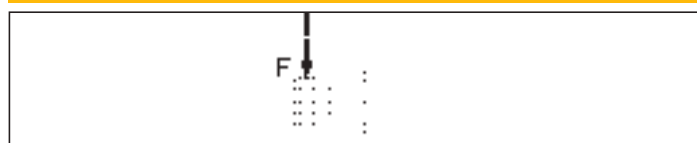

MAXIMUM PERMISSIBLE TRANSVERSE FORCE "F" (N)

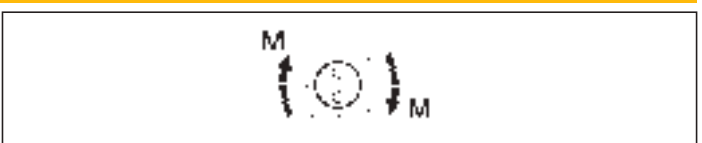
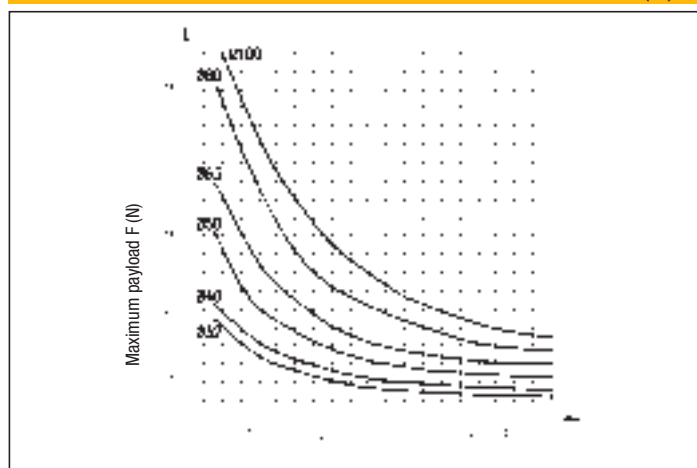

MAXIMUM PERMISSIBLE TORQUE "M" (Nm)

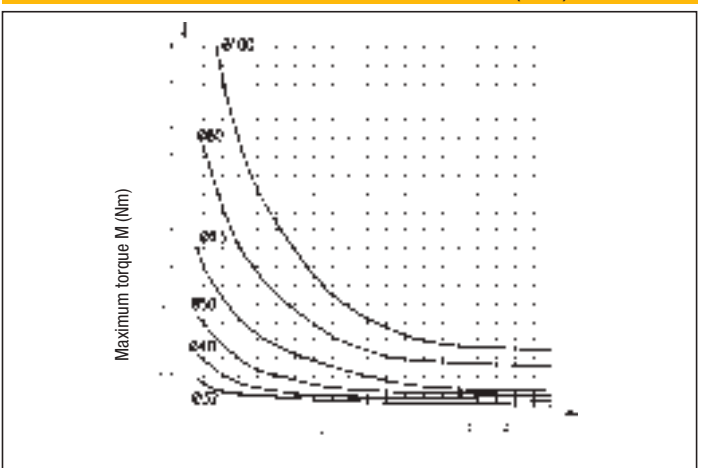

CPA BASIC CYLINDER

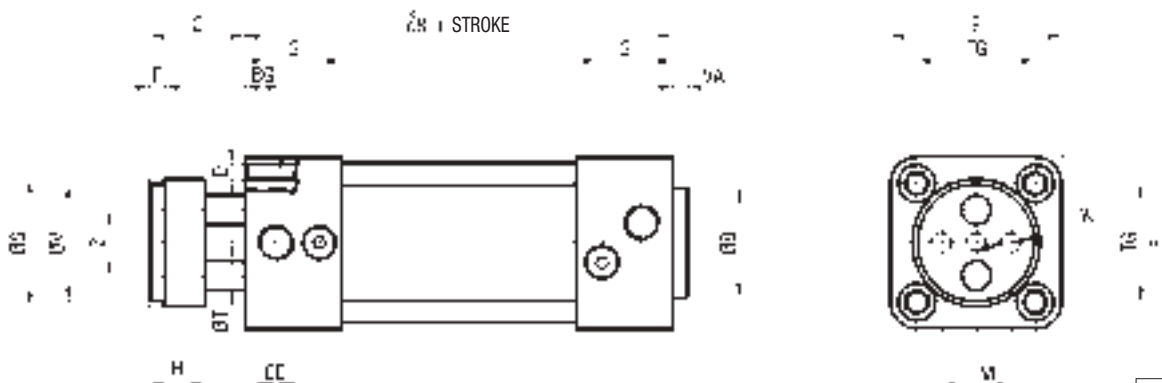

DIMENSIONS AND WEIGHTS BASIC CYLINDER

Ø	B	BG	C	D	E	EE	F	F1	G	H	K	∅8	M	S	T	TG	V	VA	Z	WEIGHT (g)	INCR (g) x 10 mm
32	30	16	26	M6	47	G1/8	4	48	28	15	M6	94	19	35	8	32,5	32	4	18	770	30
40	35	16	30	M6	53	G1/4	4	54	31,5	15	M8	105	22,5	45	10	38	40	4	22	980	43
50	40	16	37	M8	65	G1/4	5	69	31,5	18	M8	106	30	55	12	46,5	50	4	26	1570	70
63	45	16	37	M8	75	G3/8	5	69	35	22	M10	121	38	70	16	56,5	63	4	35	2320	128
80	45	16	46	M10	95	G3/8	5	86	36	22	M12	128	50	85	20	72	80	4	40	3830	132
100	55	16	51	M10	115	G1/2	5	91	41	22	M12	138	70	105	20	89	100	4	50	5600	139

THROUGH ISO ROD

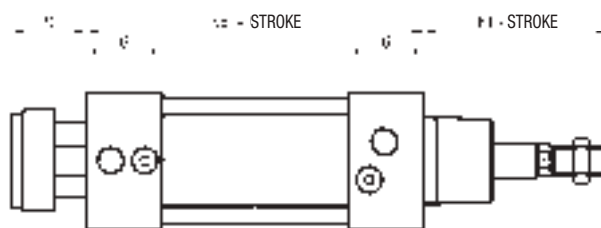

P.S.: Rod nut supplied as standard

FLANGE - STEEL - Ø 32 ÷ 50 - CPUI/F Ø
(Supplied with screws) - Ø 63 ÷ 100 - CPA/F Ø

Ø	FB H13	E	MF JS14	R JS14	TF JS14	UF	W
32	7	45	10	32	64	80	16
40	9	52	10	36	72	90	20
50	9	65	12	45	90	110	25
63	9	75	12	50	100	120	25
80	12	95	16	63	126	150	30
100	14	115	16	75	150	170	35

Ø	ZF	WEIGHT (g)
32	130	190
40	145	246
50	155	478
63	170	622
80	190	1430
100	205	1986

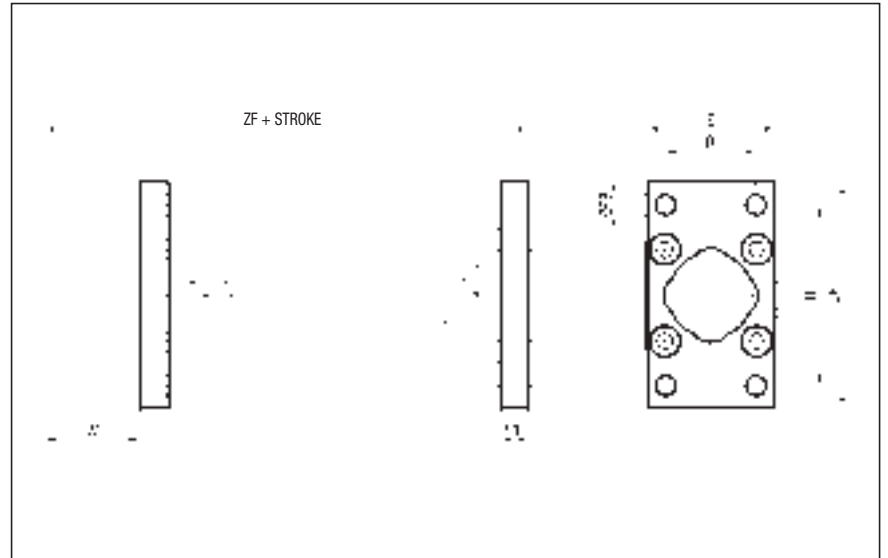

1

FOOT - STEEL - Ø 32 ÷ 50 - CPUI/PB Ø
(Supplied with screws) - Ø 63 ÷ 100 - CPA/PB Ø

Ø	AB H14	AH JS15	AT	AU	E	F	SA
32	7	32	4	24	45	35	142
40	9	36	4	28	52	36	161
50	9	45	5	32	65	47	170
63	9	50	5	32	75	45	185
80	12	63	6	41	95	55	210
100	14	71	6	41	115	57	220

Ø	SB	TR JS14	WEIGHT (g)
32	144	32	66
40	163	36	78
50	175	45	168
63	190	50	190
80	215	63	382
100	230	75	452

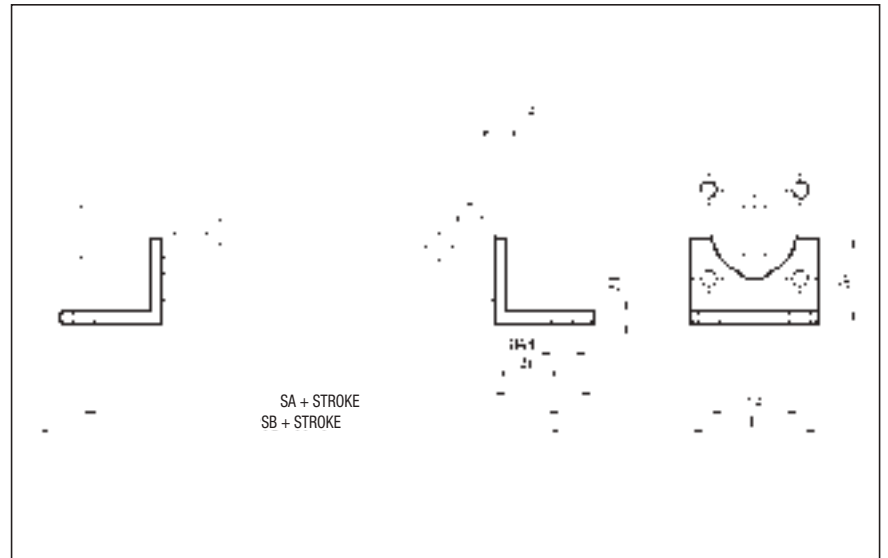

P.S.: REAR MOUNTINGS ACCESSORIES SAME OF THE CYLINDERS SERIES "X" AND "XT" ACCORDING TO ISO 15552 STANDARD (see from page 1.33)

1

DESCRIPTION

Rodless cylinders series "Z" are suitable for applications where long strokes are required, as they have been designed with reduced overall dimensions if compared to the standard cylinders with external rod. The short cylinder (version "K") has a basic length (0-stroke) up to 40% shorter than the "S" standard version. The guided versions (options "F" & "FF") allow the translation of non-guided loads and offer great resistance to transversal forces. Cylinders series "Z" are supplied with magnetic piston type as standard and, upon request, comply with ATEX directive, 2G category.



TECHNICAL DATA

Operating pressure	2 ÷ 8 bar
Working temperature	0 ÷ +80 °C (-20 °C with dry air)
Fluid	Filtered, unlubricated, continuous lubricated or dry compressed air
Versions	Standard yoke, short yoke
Bore	Ø 18, 25, 32, 40, 50, 63
Port size	Ø 18 = M5 Ø 25 - 32 = G 1/8 Ø 40 - 50 = G 1/4 Ø 63 = G 3/8
Decelerators length	Ø 18 25 32 40 50 63 mm 15 18 24 34 40 49
Maximum strokes (mm)	Ø 18 ÷ 63 = 6000

P.S.: in the Ø 18 size, it's not possible to mount the magnetic sensors series "FM100" in the opposite side of the yoke.

MATERIALS

End caps	Anodized aluminium alloy
Cylinder barrel	Extruded profile, anodized aluminium alloy
Sealing strip	Polyamide
Cover strip	AISI 304 stainless steel
Head wiper	Acetal resin
Piston	Aluminium alloy with piston seal in acetal resin
Yoke	Anodized aluminium alloy
Decelerators ogives	Brass
Seals	Polyurethane

ORDER KEY

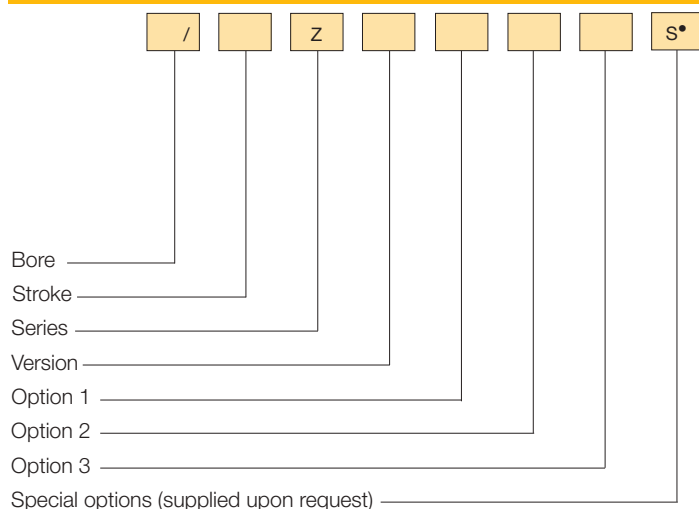

• See Chapter 1 on page 1.1.

ORDER EXAMPLES

Rodless cylinder Ø 50, 500 mm stroke, with standard yoke and ports:
50/500 ZS

Rodless cylinder Ø 40, 1000 mm stroke, short yoke, single guide, one side ports: **40/1000 ZKF1**

Rodless cylinder Ø 32, 1000 mm stroke, short yoke, double guide, one side ports, ATEX: **32/1000 ZKFF1**

VERSION

S Standard yoke **K** Short yoke

OPTION 1

F Single guide **FF** Double guide*

OPTION 2

1 One side ports** **2** Bottom ported**

OPTION 3

/EX Consistent with the ATEX directive  II 2G c T5 -20°C<Ta<80°C

** Supplied only for "S" version

** Supplied from Ø 25 to Ø 63

SPARE PARTS

Seals kit - Polyurethane	Ø/SG/Z
Sealing strip (min. 500 mm)	Ø/BP/Z/mm
Cover strip (min. 500 mm)	Ø/BM/Z/mm

TECHNICAL INFORMATION

MAXIMUM PERMISSIBLE FORCES

Ø	F x in (N) a 6 bar - speed ≤ 0,35 m/s					F z in (N) - speed ≤ 0,35 m/s					F y in (N) - speed ≤ 0,35 m/s				
	ZS	ZK	ZSF	ZSFF	ZKF	ZS	ZK	ZSF	ZSFF	ZKF	ZS	ZK	ZSF	ZSFF	ZKF
18	140	140	140	140	140	300	140	370	550	150	80	40	370	550	150
25	270	270	270	270	270	480	230	800	1200	250	110	55	800	1200	250
32	440	440	440	440	440	650	320	1200	1800	450	165	70	1200	1800	450
40	680	680	680	680	680	800	400	1600	2400	600	225	100	1600	2400	600
50	1060	1060	1060	1060	1060	1060	480	2100	3200	900	325	140	2100	3200	900
63	1680	1680	1680	1680	1680	1680	590	2800	4200	1100	435	180	2800	4200	1100

Ø	Resultant Force Ft (N)														
	Speed = 0,75 m/s					Speed = 1 m/s					Speed = 1,5 m/s				
	ZS	ZK	ZSF	ZSFF	ZKF	ZS	ZK	ZSF	ZSFF	ZKF	ZS	ZK	ZSF	ZSFF	ZKF
18	80	40	100	150	50	40	25	58	80	30	20	10	26	20	12
25	155	90	280	420	100	90	50	160	210	60	40	25	65	80	30
32	280	200	510	750	250	155	110	300	400	135	70	45	140	170	65
40	500	420	1000	1500	480	290	240	550	750	280	125	110	250	300	140
50	790	750	1500	2200	800	420	440	850	1150	480	195	190	380	460	220
63	1500	1500	2500	3700	1500	850	850	1400	1900	950	370	380	610	740	400

P.S.: $\Sigma F = \text{Resultant force} = \sqrt{F_x^2 + F_z^2 + F_y^2}$

MAXIMUM PERMISSIBLE TORQUE

Ø	M x in (Nm)					M z in (Nm)					M y in (Nm)				
	ZS	ZK	ZSF	ZSFF	ZKF	ZS	ZK	ZSF	ZSFF	ZKF	ZS	ZK	ZSF	ZSFF	ZKF
18	1	0,4	3,5	5,2	1,8	3	1,7	6	9	1,8	3	1,7	6	9	1,8
25	2	0,7	10	15	4	13	2,7	20	30	4	13	2,7	20	30	4
32	3,5	1	25	37	10	25	5	45	67	10	25	5	45	67	10
40	5,5	2	40	60	16	40	8,5	75	110	16	40	8,5	75	110	16
50	10	3,5	80	120	30	65	13	150	220	30	65	13	150	220	30
63	16	5	110	170	45	100	18	250	370	45	100	18	250	370	45

MAXIMUM PERMISSIBLE FORCE "Fz" (as a function of the distance "L" between supports and of the deflection request)

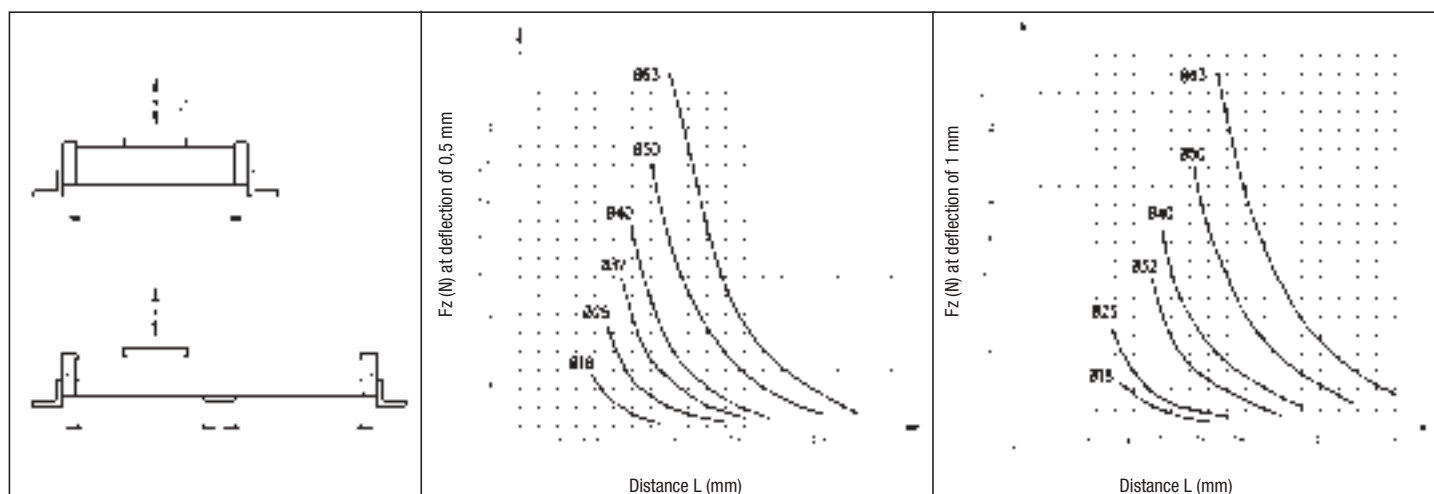

1

ZS BASIC CYLINDER WITH STANDARD YOKE

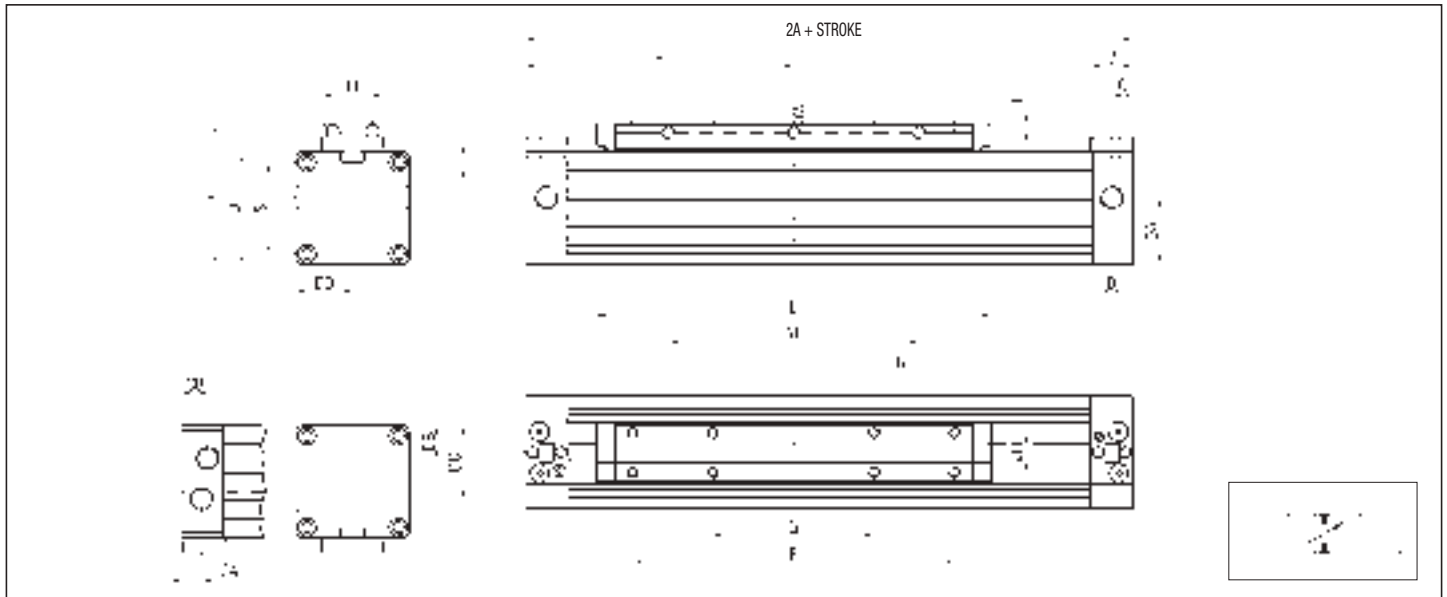

DIMENSIONS AND WEIGHTS ZS BASIC CYLINDER

Ø	A	AF	AM	B	C	CA	CB	D	DA	DB	DC	DD	E	F	G	J	M	N	O	S	T	U	W	WEIGHT (g)	INCR. (g) x10 mm
18	80	50	10	16,5	6,5	-	-	M5	17,5	-	-	15	103	75	-	3	15,5	M3x6	3,5	23,5	M3x7	30	39	300	15
25	100	70	13	20	8,5	7	13	G1/8	25,5	14	28	21	131	100	50	3,5	20	M4x7	4,5	33	M4x9	42	53	600	26
32	120	100	16	20	8,5	7	13	G1/8	32	17,5	34,5	26	171	140	70	4,5	25	M5x9	5,5	41	M5x10	52	65	1100	36
40	150	140	22	24	11	9,5	14,5	G1/4	37,5	20	42	31,5	220	180	90	5	33	M6x10	7	51	M6x12	63	79	1800	48
50	180	180	29	24	11	9,5	14,5	G1/4	47,5	26	52	39	280	220	110	6,5	42	M8x12,5	7	63	M8x12	78	96	3200	74
63	215	230	40	30	14,5	11	18,5	G3/8	59,5	30	62	46,5	333	280	140	8	54	M8x15	9	78	M8x12	93	113,5	5600	100

ZK BASIC CYLINDER WITH SHORT YOKE

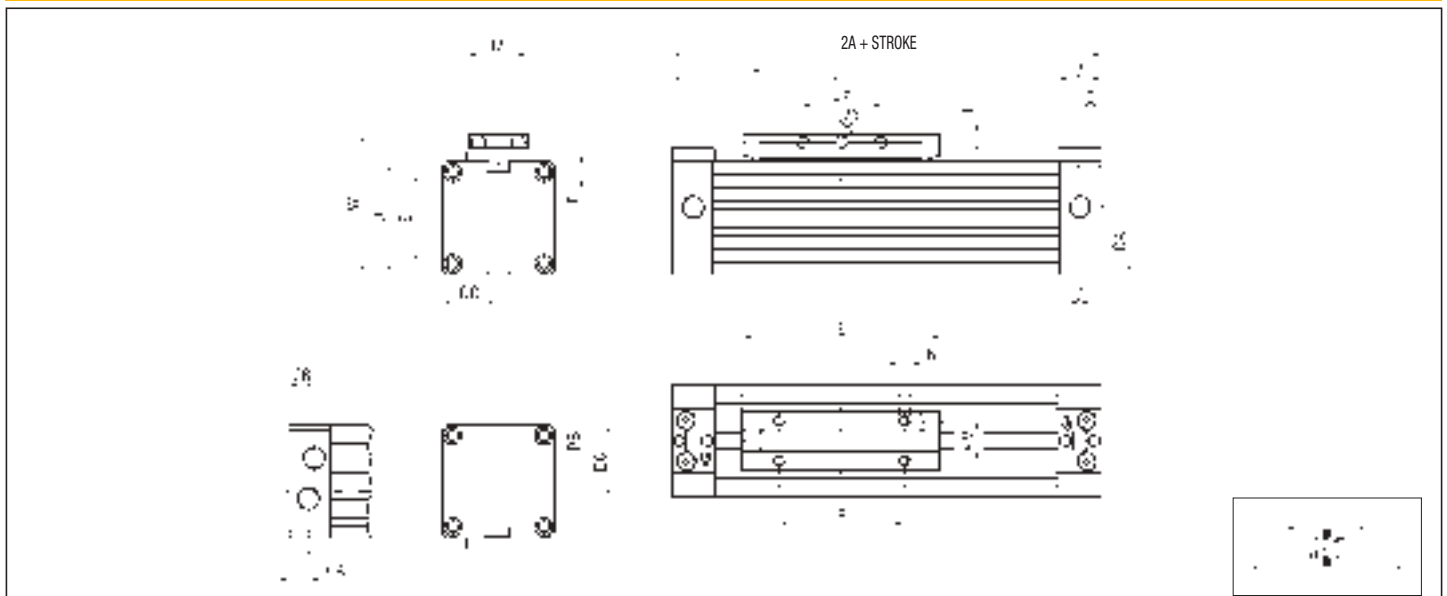

DIMENSIONS AND WEIGHTS ZK BASIC CYLINDER

Ø	A	AM	B	C	CA	CB	D	DA	DB	DC	DD	E	F	J	M	N	O	S	T	U	W	WEIGHT (g)	INCR. (g) x10 mm
18	57,5	10	16,5	6,5	-	-	M5	17,5	-	-	15	58	30	3	15,5	M3x6	3,5	23,5	M3x7	30	39	200	15
25	67,5	13	20	8,5	7	13	G1/8	25,5	14	28	21	66	35	3,5	20	M4x7	4,5	33	M4x9	42	53	400	26
32	77,5	16	20	8,5	7	13	G1/8	32	17,5	34,5	26	86	55	4,5	25	M5x9	5,5	41	M5x10	52	65	700	36
40	95	22	24	11	9,5	14,5	G1/4	37,5	20	42	31,5	110	70	5	33	M6x10	7	51	M6x12	63	79	1200	48
50	105	29	24	11	9,5	14,5	G1/4	47,5	26	52	39	130	70	6,5	42	M8x12,5	7	63	M8x12	78	96	2000	74
63	125	40	30	14,5	11	18,5	G3/8	59,5	30	62	46,5	153	100	8	54	M8x15	9	78	M8x12	93	113,5	3200	100

ZSF BASIC CYLINDER WITH STANDARD YOKE AND SINGLE GUIDE

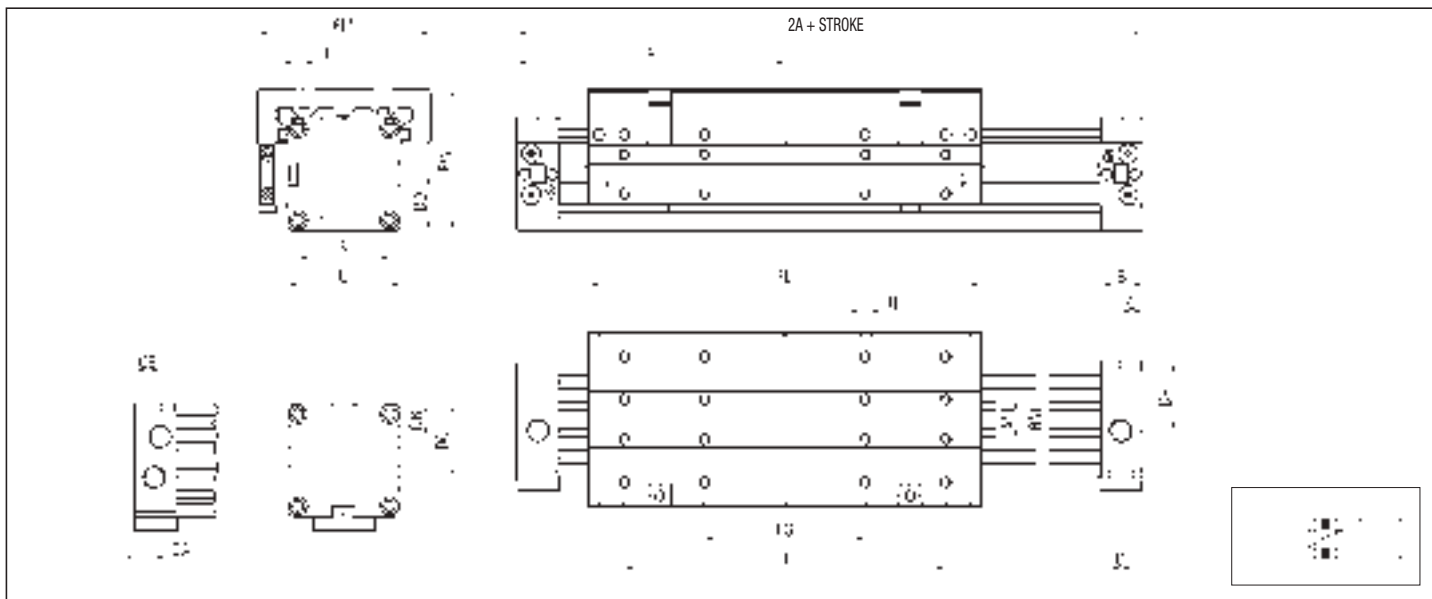

DIMENSIONS AND WEIGHTS ZSF BASIC CYLINDER

Ø	A	AM	B	BM	C	CA	CB	D	DA	DB	DC	DD	FE	FF	FG	FM	FW	N	S	T	U	WEIGHT (g)	INCR. (g) x10 mm
18	80	10	16,5	35	6,5	-	-	M5	17,5	-	-	15	103	75	-	50	39	M4x7,5	23,5	M3x7	30	400	15
25	100	13	20	45	8,5	7	13	G1/8	25,5	14	28	21	131	100	50	66	53	M4x8	33	M4x9	42	900	26
32	120	16	20	55	8,5	7	13	G1/8	32	17,5	34,5	26	171	140	70	80	65	M5x10	41	M5x10	52	1500	36
40	150	22	24	70	11	9,5	14,5	G1/4	37,5	20	42	31,5	220	180	90	97	79	M6x12	51	M6x12	63	2800	48
50	180	29	24	85	11	9,5	14,5	G1/4	47,5	26	52	39	280	220	110	116	96	M8x16	63	M8x12	78	4900	74
63	215	40	30	105	14,5	11	18,5	G3/8	59,5	30	62	46,5	333	280	140	136	113,5	M8x16	78	M8x12	93	8000	100

ZSFF BASIC CYLINDER WITH STANDARD YOKE AND DOUBLE GUIDE

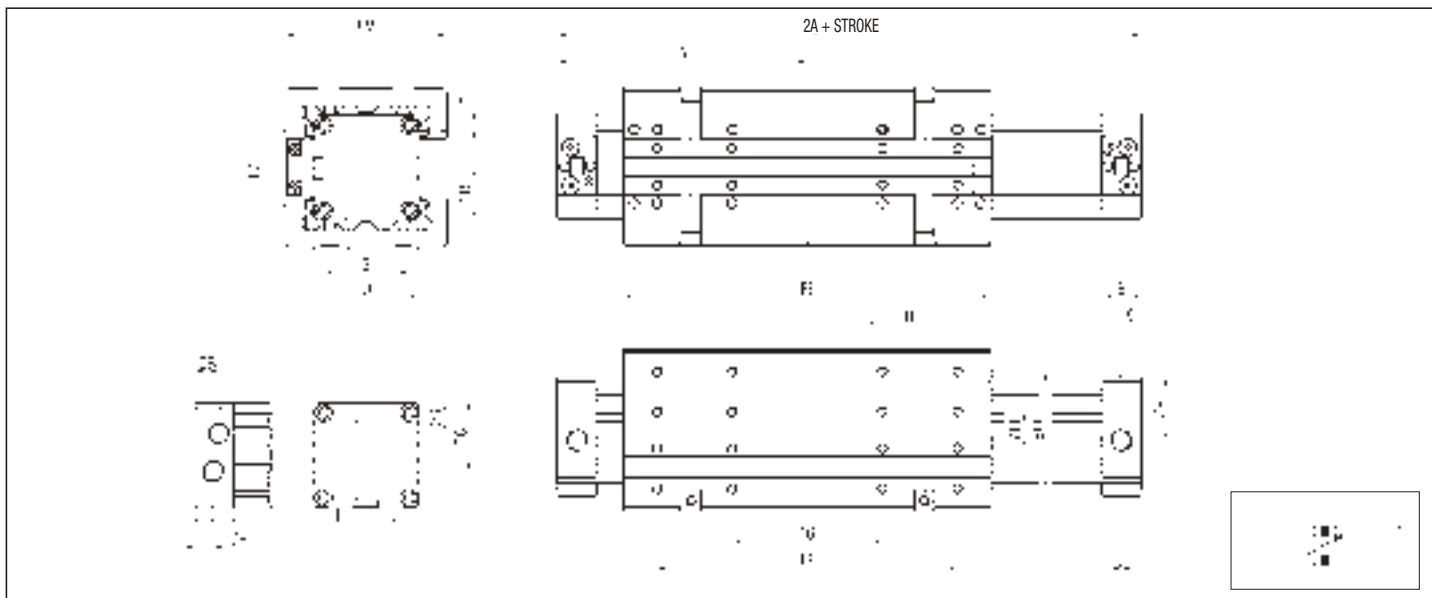

DIMENSIONS AND WEIGHTS ZSFF BASIC CYLINDER

Ø	A	AM	B	BM	C	CA	CB	D	DA	DB	DC	DD	FE	FF	FG	FM	FW	N	S	T	U	WEIGHT (g)	INCR. (g) x10 mm
18	80	10	16,5	35	6,5	-	-	M5	17,5	-	-	15	103	75	-	50	50	M4x7,5	23,5	M3x7	30	500	15
25	100	13	20	45	8,5	7	13	G1/8	25,5	14	28	21	131	100	50	66	64	M4x8	33	M4x9	42	1200	26
32	120	16	20	55	8,5	7	13	G1/8	32	17,5	34,5	26	171	140	70	80	78	M5x10	41	M5x10	52	1900	36
40	150	22	24	70	11	9,5	14,5	G1/4	37,5	20	42	31,5	220	180	90	97	95	M6x12	51	M6x12	63	3800	48
50	180	29	24	85	11	9,5	14,5	G1/4	47,5	26	52	39	280	220	110	116	114	M8x16	63	M8x12	78	6600	74
63	215	40	30	105	14,5	11	18,5	G3/8	59,5	30	62	46,5	333	280	140	136	134	M8x16	78	M8x12	93	10400	100

ZKF BASIC CYLINDER WITH SHORT YOKE AND SINGLE GUIDE

1

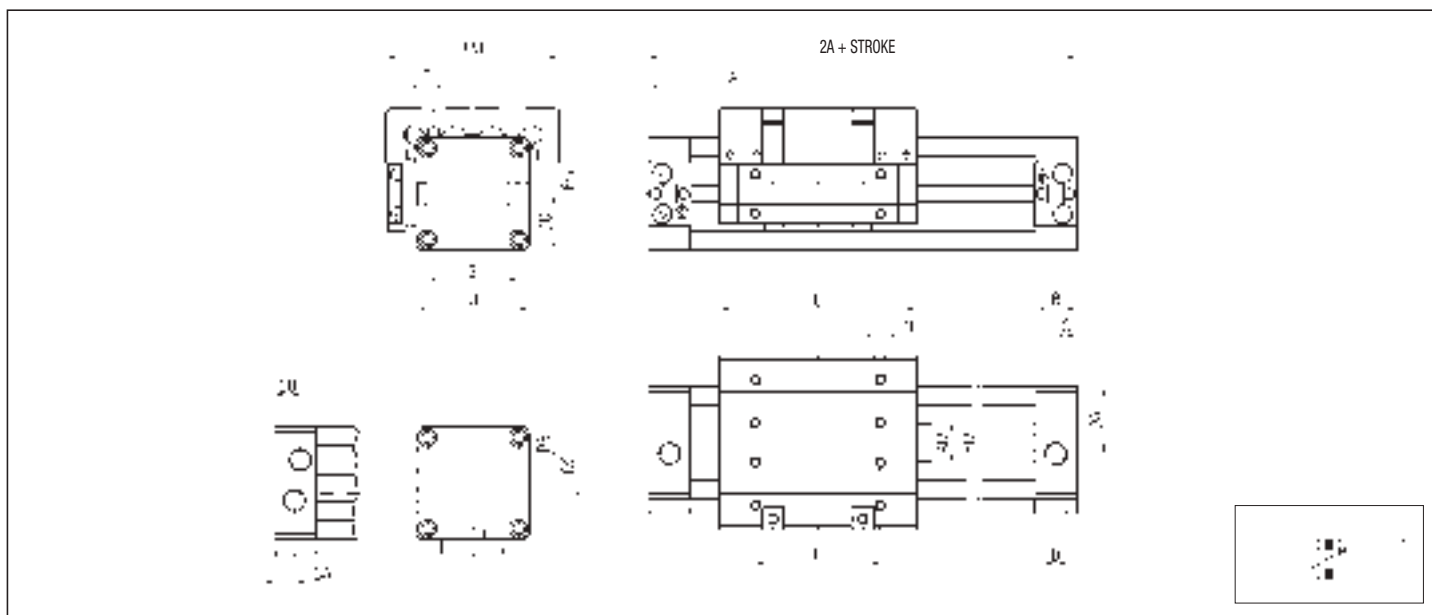

DIMENSIONS AND WEIGHTS ZKF BASIC CYLINDER

Ø	A	AM	B	BM	C	CA	CB	D	DA	DB	DC	DD	E	F	FM	FW	N	S	T	U	WEIGHT (g)	INCR. (g) x10 mm
18	57,5	10	16,5	35	6,5	-	-	M5	17,5	-	-	15	58	30	50	39	M4x7,5	23,5	M3x7	30	300	15
25	67,5	13	20	45	8,5	7	13	G1/8	25,5	14	28	21	66	35	66	53	M4x8	33	M4x9	42	600	26
32	77,5	16	20	55	8,5	7	13	G1/8	32	17,5	34,5	26	86	55	80	65	M5x10	41	M5x10	52	1150	36
40	95	22	24	70	11	9,5	14,5	G1/4	37,5	20	42	31,5	110	70	97	79	M6x12	51	M6x12	63	2000	48
50	105	29	24	85	11	9,5	14,5	G1/4	47,5	26	52	39	130	70	116	96	M8x16	63	M8x12	78	3200	74
63	125	40	30	105	14,5	11	18,5	G3/8	59,5	30	62	46,5	153	100	136	113,5	M8x16	78	M8x12	93	6400	100

FEET (PAIR) - ALUMINIUM - ZPB Ø

Ø	AA	AB	AC	AD	AE	AH	WEIGHT (g)
18	15	2	10	20	6	2	35
25	18	2	12,5	30	6	2	40
32	20	2,5	13,5	40	7	3	75
40	25	2,5	17,5	50	9	3	115
50	28	3	20	60	9	3	225
63	30	3	21	75	11	4,5	280



MIDDLE SUPPORTS (PAIR) - ALUMINIUM - ZTI Ø

Ø	AE	AH	BA	BB	BC	BD	BE	BF	WEIGHT (g)
18	6	2	56	46	36,5	23	2,5	8,25	10
25	6	2	70	60	50	28	3,5	11	15
32	7	3	85	73	61,5	33	4	13,8	30
40	9	3	105	90	75	38	4,5	16	45
50	9	3	122	106	91	43	5	19	60
63	11	4,5	144	125	107	48	6	22	80

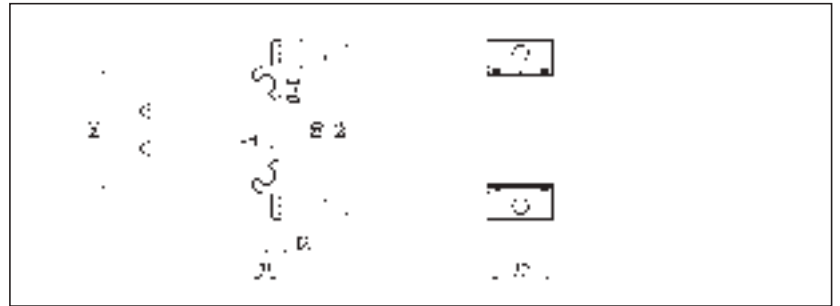

NARROW SWINGING BRIDGE - ALUMINIUM - ZCS Ø

Ø	CA	CB	CC	CD	CE	CF	CG	CK
18	50	25,5	30	9	M5	54	2,5	M4
25	60	30	40	14	M5	70	3	M4
32	70	37	50	16	M6	86	3,5	M5
40	80	47	60	22	M8	107	4,5	M6
50	90	56	70	30	M8	123	4,5	M6
63	100	73	80	40	M10	145,5	5	M8

Ø	CJ	CH	WEIGHT (g)
18	4	4	45
25	4	4	60
32	6	6	115
40	8	8	220
50	8	8	275
63	8	8	470

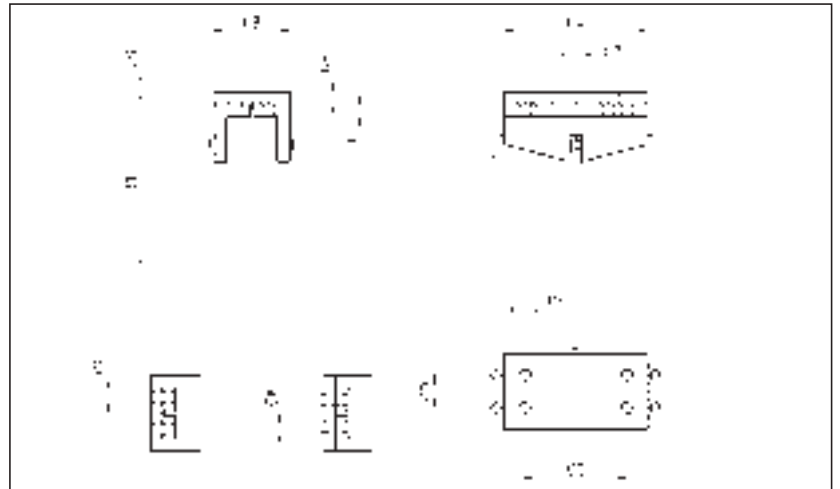

LARGE SWINGING BRIDGE - ALUMINIUM - ZCL Ø

Ø	CA	CB	CC	CD	CE	CF	CG	CK
18	50	41,5	30	34	M5	54	2,5	M4
25	60	50	40	38	M5	70	3	M4
32	70	60	50	48	M6	86	3,5	M5
40	80	80	60	60	M8	107	4,5	M6
50	90	95	70	70	M8	123	4,5	M6
63	100	120	80	80	M10	145,5	5	M8

Ø	CJ	CH	WEIGHT (g)
18	4	4	50
25	4	4	80
32	6	6	145
40	8	8	275
50	8	8	350
63	8	8	575

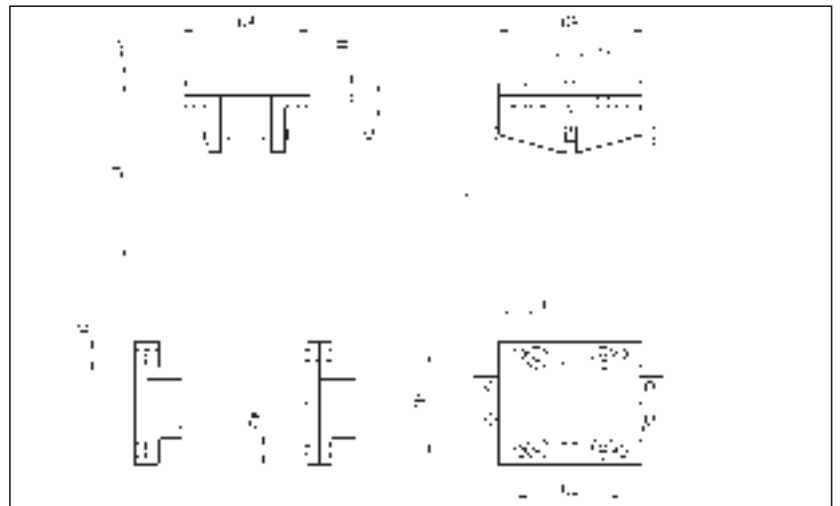

1

DESCRIPTION

Cylinders series "HB" are manufactured to be fixed directly on the machinery without the use of fixings accessories. In fact the end caps act as a mounting device in the versions: hinge-mounted, screw-mounted, feet-mounted, front flange-mounted, rear flange-mounted. The double acting hinge-mounted versions and rear flange-mounted are available with reduced end caps. Upon request, cylinders series "HB" comply with ATEX directive, 2GD category.

TECHNICAL DATA

Operating pressure	1,5 ÷ 10 bar
Working temperature	0 ÷ +80 °C (-20 °C with dry air) 0 ÷ +150 °C with seals for high temperatures (-20 °C with dry air)
Fluid	Filtered, unlubricated, continuous lubricated or dry compressed air
Versions	Double acting; Single acting front spring; Single acting rear spring; Through rod
Bore	Ø 20, 27, 35, 40, 50, 58, 70, 85, 100
Port size	Ø 20 ÷ 50 = G 1/8 Ø 58 ÷ 100 = G 1/4
Standard strokes (mm)	10, 15, 20, 30, 40, 50, 60, 70, 80, 90, 100, 150, 200, 250
Max. strokes double acting (mm)	Ø 20 ÷ 58 = 2000; Ø 70 ÷ 100 = 1000
Maximum strokes single acting	Ø 20 27 35 40 50 58 70 85 100 mm 20 25 35 60 70 60 70 90 100
Maximum strokes single acting (version "S") with spacers	Ø 20 27 35 40 50 58 70 85 100 mm 60 75 105 180 210 180 210 270 300
Spring theoretical tractive force	See technical data on page 0.13

ORDER KEY

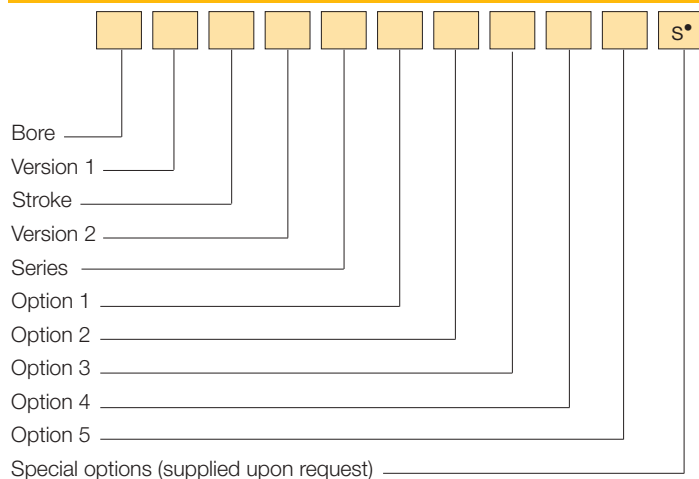

• See Chapter 1 on page 1.1.

ORDER EXAMPLES

Basic cylinder Ø 27, 25 mm stroke, single acting front spring, feet-mounted: **27/25 SPB**

Cylinder Ø 20, through rod, 100 mm stroke, double acting, feet-mounted: **20R100 DPB**

Basic cylinder Ø 58, 50 mm stroke, double acting, hinge-mounted, stainless steel piston rod, brass cylinder barrel: **58/50 DVB 14**

Basic cylinder Ø 35, 70 mm stroke, double acting, hinge-mounted, reduced end cap: **35/70 DCBC**

Basic cylinder Ø 40, 50 mm stroke, double acting, hinge-mounted, ATEX: **40/50 DCB/EX**



MATERIALS

End caps	Aluminium alloy
Cylinder barrel	Ø 20 ÷ 100: Extruded tube, anodized aluminium alloy; Extruded tube, brass (supplied upon request)
Piston rod	C45 chromium-plated steel AISI 303 rolled stainless steel
End cap nut	Steel
Piston rod bearing	Bronze-iron 20%, sintered, self-lubricating
Piston guide shoe	Acetal resin
Piston	Aluminium alloy
Seals	NBR rubber Viton®
Springs	Springs steel

VERSION 1

/ Basic cylinder **R** Through rod*

VERSION 2

D Double acting **Y** Single acting front spring**
S Single acting front spring

SERIES

CB Hinge-mounted **FAB** Front flange-mounted
VB Screw-mounted **FPB** Rear flange-mounted
PB Feet-mounted

OPTION 1

C Reduced end cap***

OPTION 2

1 Stainless steel piston rod **3** Stainless steel piston rod and seals for high temperatures
2 Seals for high temperatures

OPTION 3

4 Brass cylinder barrel

OPTION 4

5 Rod wipers (supplied as standard from Ø 20 ÷ 70 with option "C" - reduced end cap)

OPTION 5

/EX Consistent with the ATEX directive II 2GD c T5 T100°C < Ta < 80°C

* Series "FPB" excluded

** Dimensions are different from the versions "D" and "S"

*** Supplied only with series "DCB", "YCB", "DFPB", "YFPB" and with the version "R" of series "DFAB" and "DVB"

SPARE PARTS

SEALS KIT			
NBR	Ø/SG/HB	For high temperatures	Ø/SG/HB2
Through rod NBR	Ø/SG/R/HB	Through rod, for high temperatures	Ø/SG/R/HB2

BASIC CYLINDER HINGE-MOUNTED - CB

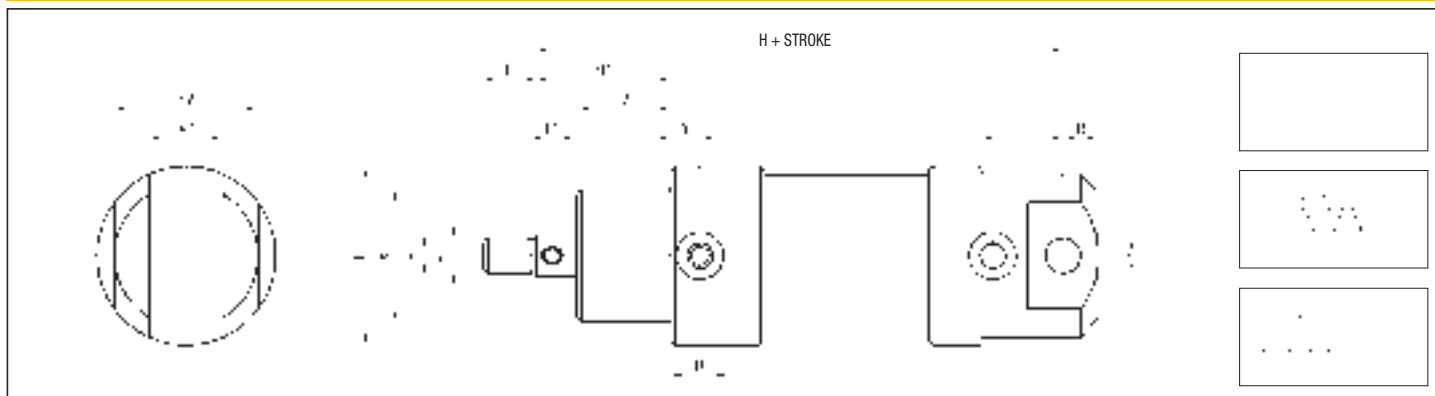

REDUCED END CAP

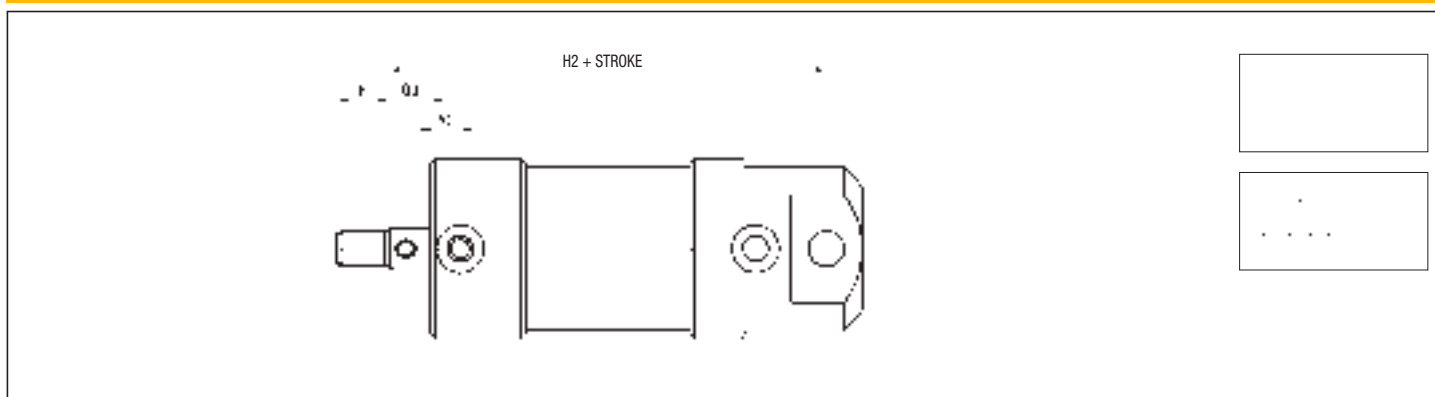

DIMENSIONS AND WEIGHTS BASIC CYLINDER CB

Ø	D	D1	E	F1	H	H2	I	J H8	K1 0/+0,2	K2 0/-0,2	L	M	N	Q1	Q3	R	S	Y	Y2	WEIGHT (g)	INCREM. (g) every 10 mm
20	8	M6	9	3	85	72	10	5	8	22	30	16	6	24	8	G 1/8	24	10	11,5	200	15
27	10	M8	12	4	96	76	21	6	9	25	35	20	7	30	10	G 1/8	28	9,5	11,5	289	20
35	12	M10	15	4	106	84	23	8	12	32	45	24	9	36	12	G 1/8	32	9,5	10	396	32
40	12	M10	15	4	121	90	26	10	18	40	50	32	10	44	12	G 1/8	36	10	10	503	35
50	14	M12	18	5	130	101	28	12	25	49	61	32	12	46	14	G 1/8	42	10	10	793	44
58	16	M14	21	5	140	110	33	14	26	54	70	32	14	48	16	G 1/4	45	12	14	1181	53
70	18	M16	24	5	151	122	35	16	35	67	82	35	16	53	18	G 1/4	50	14	16	1474	64
85	20	M18	27	6	168	128	36	18	40	76	98	44,5	18	64,5	20	G 1/4	60	12,5	14	2033	89
100	24	M20	30	6	191	142	45	20	40	80	114	50	20	74	24	G 1/4	70	14	19	3250	110

ACCESSORIES

PIVOT FOR FEMALE REAR HINGE - STEEL - HB/SEC Ø

Ø	BU	EK f7	EL	WEIGHT (g)
20	28	5	23	4,5
27	31	6	26	7
35	38	8	33	15
40	47	10	41	29
50	56	12	50	50
58	62	14	55	76
70	75	16	68	118
85	84	18	77	168
100	88	20	81	217

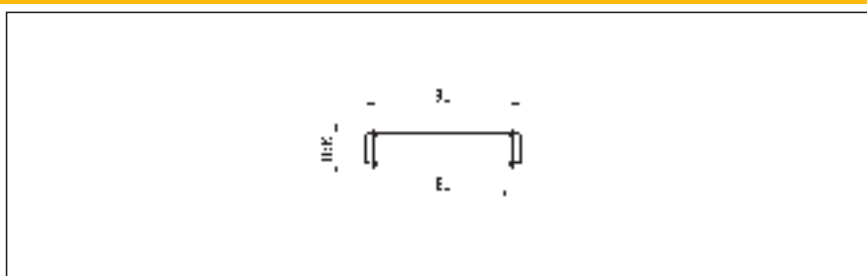

1

BASIC CYLINDER SCREW-MOUNTED - VB

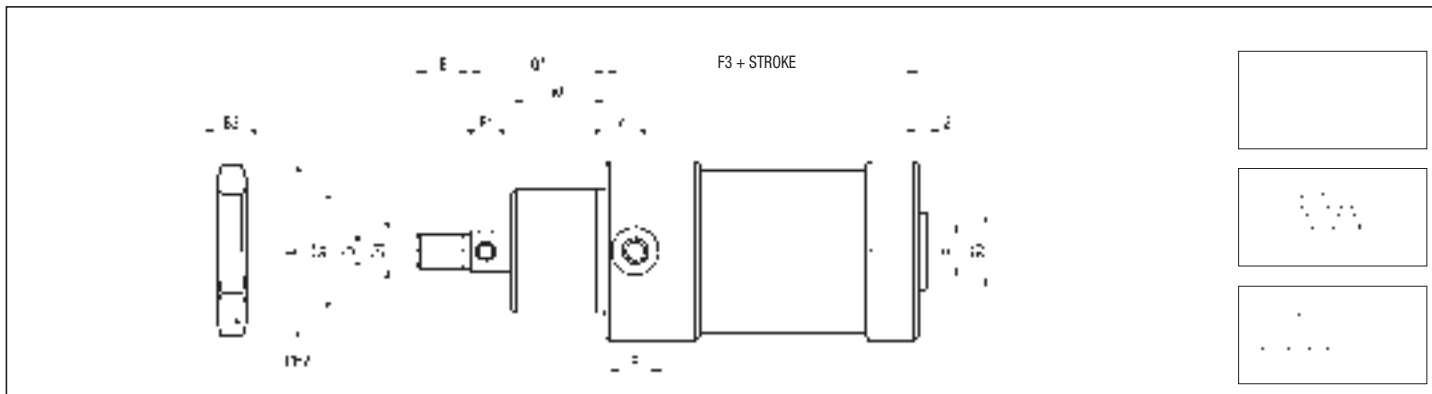

P.S.: End cap nut (HB/DT Ø) supplied as standard. Contact the commercial office for further nuts.

THROUGH ROD

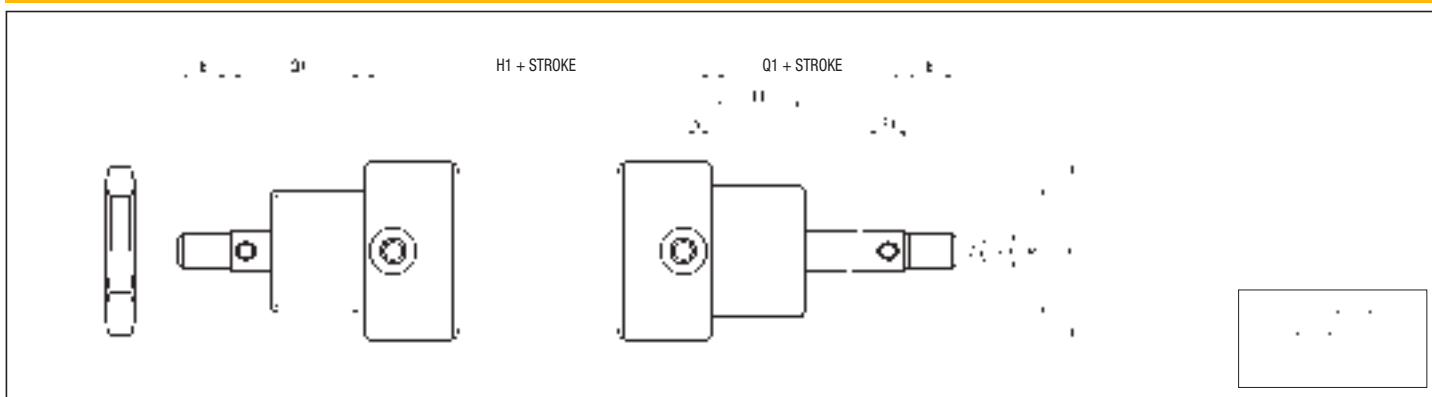

P.S.: End cap nut (HB/DT Ø) supplied as standard. Contact the commercial office for further nuts.

THROUGH ROD, REDUCED END CAP

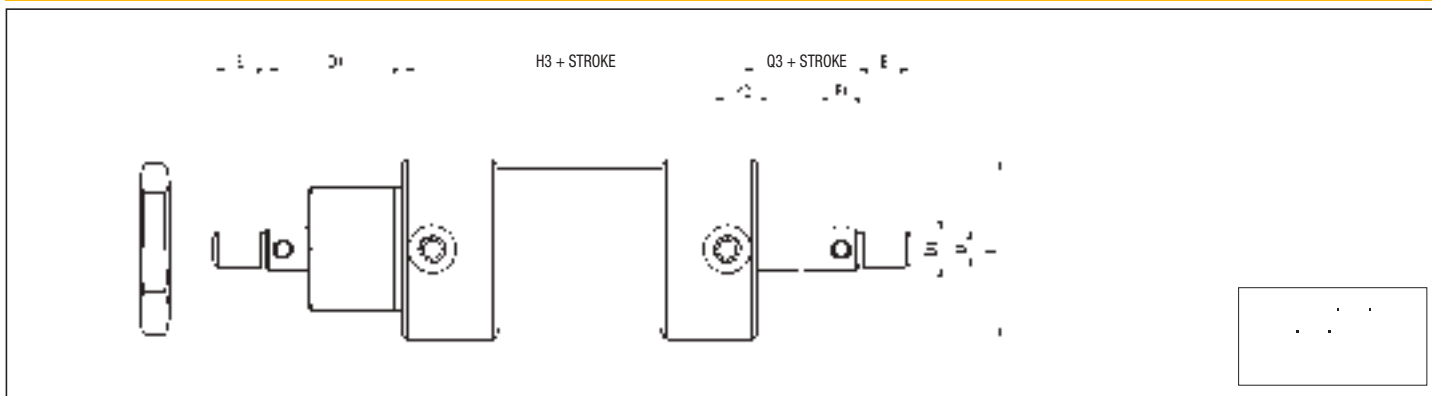

P.S.: End cap nut (HB/DT Ø) supplied as standard. Contact the commercial office for further nuts.

DIMENSIONS AND WEIGHTS BASIC CYLINDER VB

Ø	B2	CH2	D	D1	E	F1	F3	H1	H3	I2	L	M	Q1	Q3	R	S	S5	S7	Y	Y2	WEIGHT (g)	INCREM. (g) every 10 mm
20	5	32	8	M6	9	3	41	58	61	3,5	30	16	24	8	G 1/8	24	14	M24x2	10	11,5	129	15
27	6	35	10	M8	12	4	45,5	60,5	62,5	3,5	35	20	30	10	G 1/8	28	14	M28x2	9,5	11,5	160	20
35	7	40	12	M10	15	4	47,5	61,5	63,5	3,5	45	24	36	12	G 1/8	32	18	M32x2	9,5	10	299,5	32
40	8	45	12	M10	15	4	51	68	69	3	50	32	44	12	G 1/8	36	24	M36x3	10	10	416	35
50	10	50	14	M12	18	5	56	70	73	3	61	32	46	14	G 1/8	42	26	M42x3	10	10	691	44
58	10	55	16	M14	21	5	59	75	77	4	70	32	48	16	G 1/4	45	30	M45x3	12	14	1028	53
70	10	60	18	M16	24	5	63	80	86	4	82	35	53	18	G 1/4	50	30	M50x3	14	16	1388	64
85	12	70	20	M18	27	6	67,5	84	88,5	4	98	44,5	64,5	20	G 1/4	60	40	M60x4	12,5	14	2024	89
100	14	85	24	M20	30	6	72	89	90	4	114	50	74	24	G 1/4	70	40	M70x4	14	19	3060	110

BASIC CYLINDER FEET-MOUNTED - PB

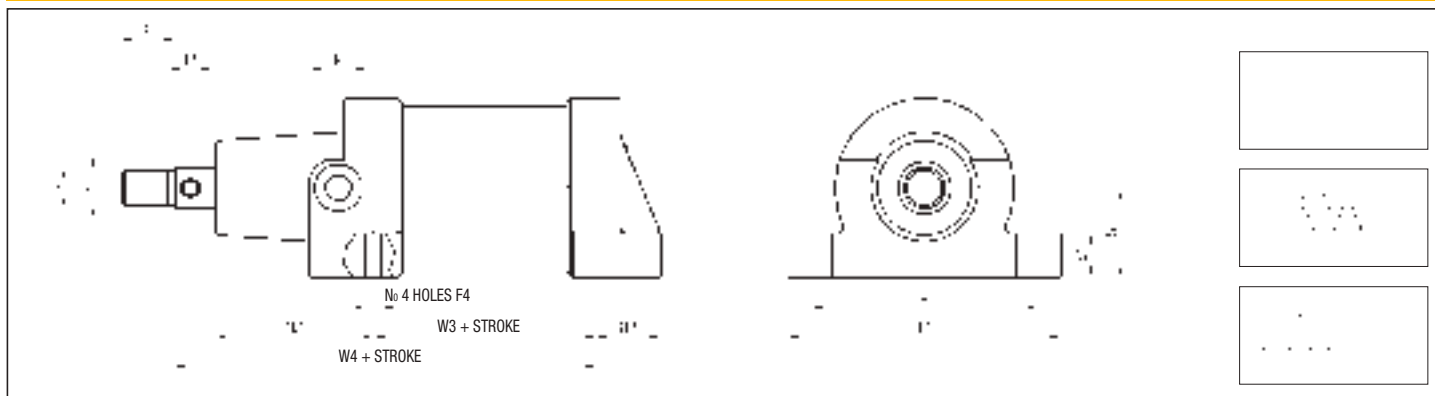

THROUGH ROD

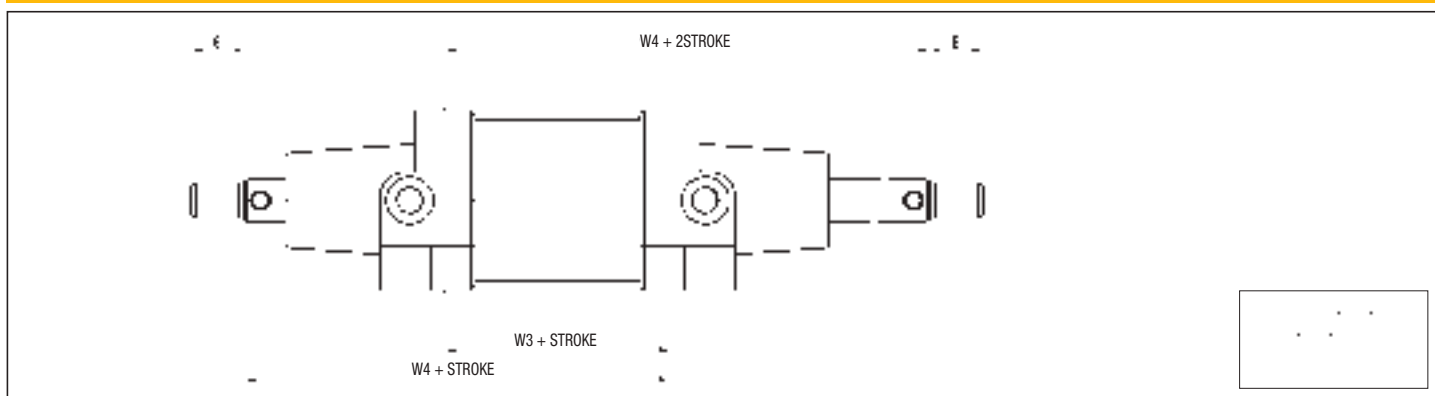

DIMENSIONS AND WEIGHTS BASIC CYLINDER PB

Ø	A	D	D1	E	F1	F4	G	L1	N2	Q2	R	S1	W3	W4	WEIGHT (g)	INCREMENT (g) every 10 mm
20	42	8	M6	9	3	4,25	17	52	13	36	G 1/8	8	18	62	181	15
27	45	10	M8	12	4	4,5	19,5	55	17	40	G 1/8	10	20	70	269	20
35	57	12	M10	15	4	5,5	22,5	69	17	44	G 1/8	12	21	77	359	32
40	64	12	M10	15	4	5,5	25	78	22	56	G 1/8	14	20	88	502	35
50	77	14	M12	18	5	5,5	30,5	93	22	54	G 1/8	16	26	94	743	44
58	86	16	M14	21	5	6,5	35	102	25	56	G 1/4	16	27	99	996	53
70	100	18	M16	24	5	6,5	41	118	26	61	G 1/4	18	28	107	1363	64
85	118	20	M18	27	6	8,5	49	138	27	72	G 1/4	20	30	122	2043	89
100	136	24	M20	30	6	8,5	57	158	28	76	G 1/4	22	33	133	3019	110

1

BASIC CYLINDER FRONT FLANGE-MOUNTED - FAB

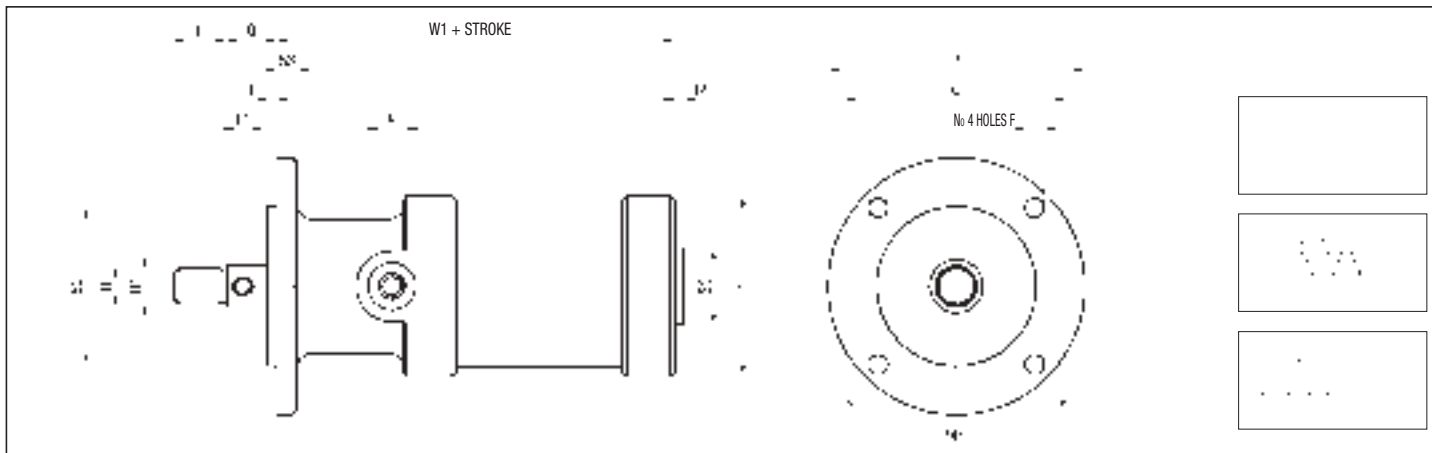

THROUGH ROD

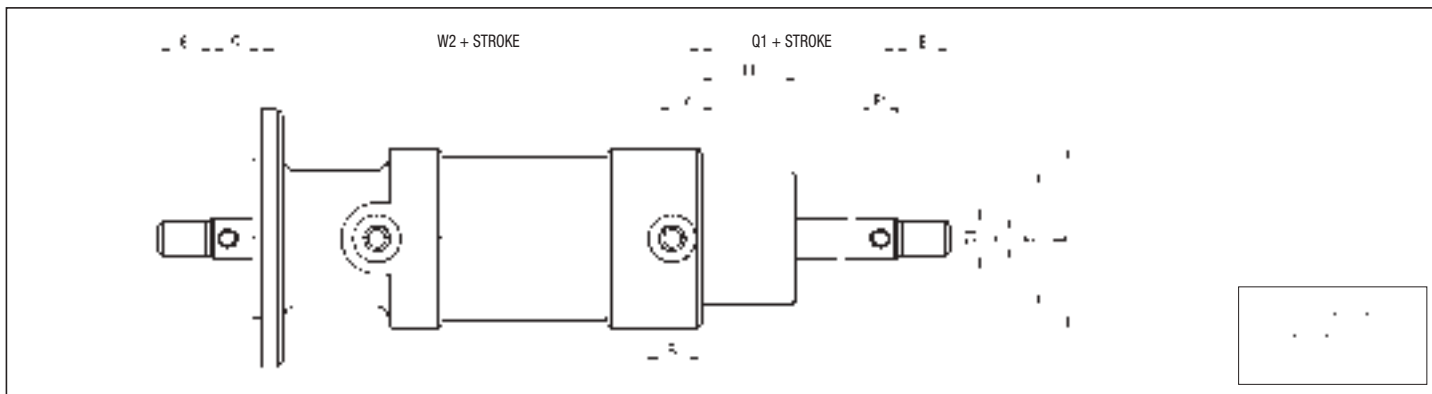

THROUGH ROD, REDUCED END CAP

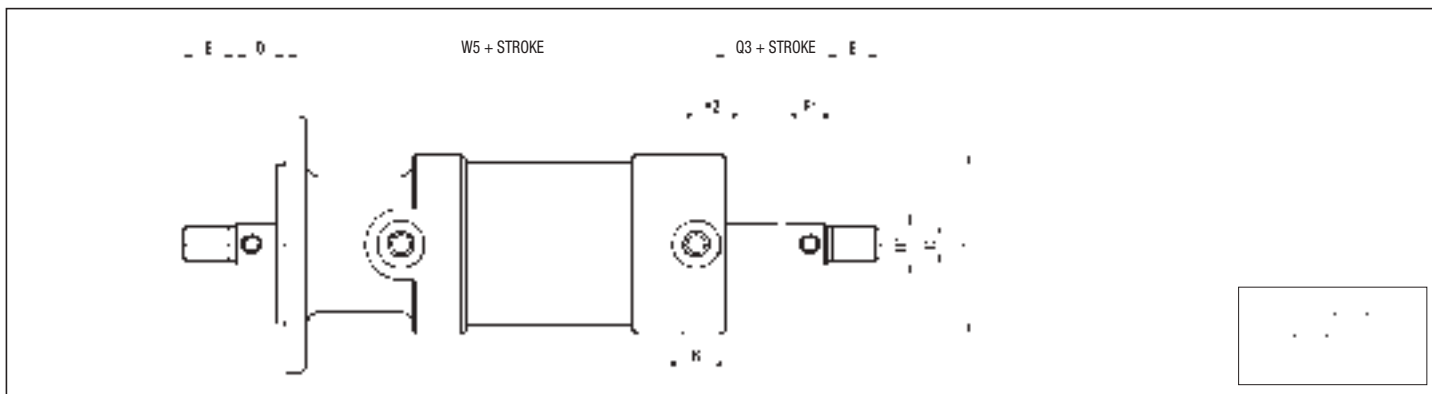

DIMENSIONS AND WEIGHTS BASIC CYLINDER - FAB

Ø	D	D1	E	F	F1	I	I2	L	M	O	P	Q	Q1	Q3	R	S	S2	S3	S5	W1	W2	W5	Y	Y2	WEIGHT (g)	INCREM. (g) every 10 mm
20	8	M6	9	4,2	3	2	3,5	30	16	39	50	10	24	8	G 1/8	24	23	4	14	55	72	75	10	11,5	91	15
27	10	M8	12	4,5	4	2	3,5	35	20	48	58	12	30	10	G 1/8	28	30	6	14	63,5	78,5	80,5	9,5	11,5	178	20
35	12	M10	15	5,5	4	2	3,5	45	24	54	66	14	36	12	G 1/8	32	36	6	18	69,5	83,5	85,5	9,5	10	317	32
40	12	M10	15	6,5	4	3	3	50	32	57	69	15	44	12	G 1/8	36	40	7	24	80	97	98	10	10	427	35
50	14	M12	18	6,5	5	3	3	61	32	75	87	17	46	14	G 1/8	42	54	7	26	85	99	102	10	10	689	44
58	16	M14	21	6,5	5	3	4	70	32	82	100	19	48	16	G 1/4	45	60	8	30	88	104	106	12	14	915	53
70	18	M16	24	8,5	5	4	4	82	35	100	119	22	53	18	G 1/4	50	70	10	30	94	111	117	14	16	1244	64
85	20	M18	27	10,5	6	4	4	98	44,5	120	140	24	64,5	20	G 1/4	60	80	11	40	103	119,5	124	12,5	14	2113	89
100	24	M20	30	10,5	6	4	4	114	50	137	160	28	74	24	G 1/4	70	88	12	40	118	135	136	14	19	3200	110

BASIC CYLINDER REAR FLANGE-MOUNTED - FPB

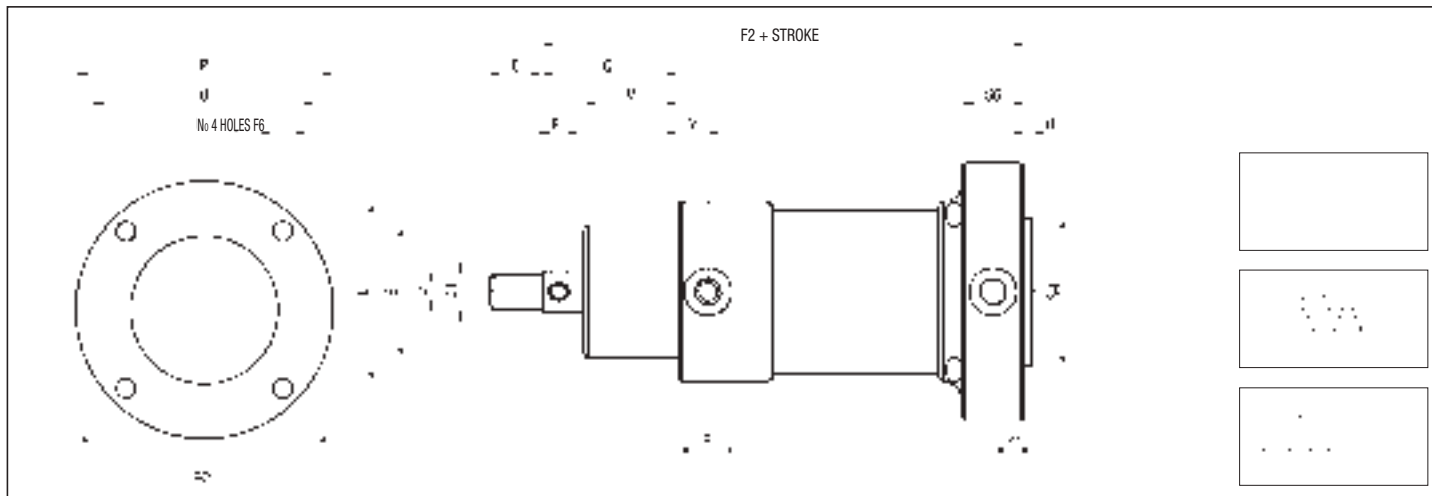

REDUCED END CAP

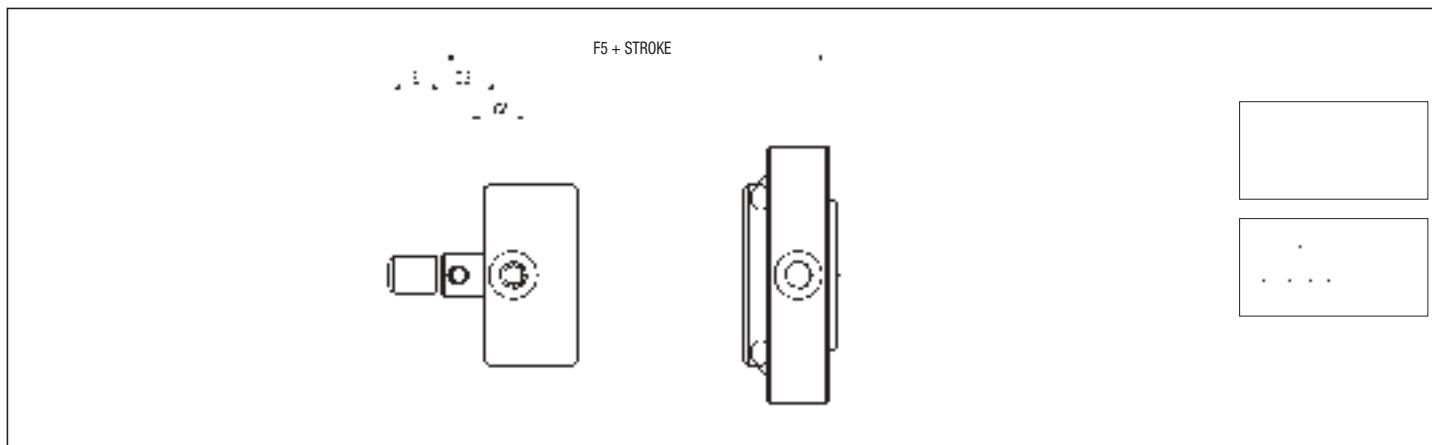

DIMENSIONS AND WEIGHTS BASIC CYLINDER FPB

Ø	D	D1	E	F1	F2	F5	F6	I1	L	M	O	P	Q1	Q3	R	S	S4	S6	Y	Y1	Y2	WEIGHT (g)	INCREM. (g) every 10 mm
20	8	M6	9	3	78	65	4,2	2	30	16	39	50	24	8	G 1/8	24	23	18	10	11	11,5	91	15
27	10	M8	12	4	89	69	4,5	2	35	20	48	58	30	10	G 1/8	28	30	19	9,5	11,5	11,5	178	20
35	12	M10	15	4	97	75	5,5	2	45	24	59	69	36	12	G 1/8	32	38	19	9,5	11,5	10	317	32
40	12	M10	15	4	109	78	5,5	3	50	32	62	74	44	12	G 1/8	36	40	21	10	13,5	10	427	35
50	14	M12	18	5	113	84	6,5	3	61	32	75	87	46	14	G 1/8	42	50	21	10	13,5	10	689	44
58	16	M14	21	5	122	92	8,5	3	70	32	86	100	48	16	G 1/4	45	62	24	12	15	14	915	53
70	18	M16	24	5	131	102	8,5	4	82	35	100	119	53	18	G 1/4	50	72	22	14	15	16	1244	64
85	20	M18	27	6	147	107	10,5	4	98	44,5	120	140	64,5	20	G 1/4	60	80	25	12,5	16,5	14	2113	89
100	24	M20	30	6	164	115	10,5	4	114	50	137	160	74	24	G 1/4	70	88	28	14	18	19	3200	110

DESCRIPTION

Steel and AISI 303 stainless steel cylinders piston rod attachments, produced according to standards that regulate cylinders manufacturing, allow the cylinder piston rod to couple with the corresponding system that has to be enlivened.



FEMALE PISTON ROD CLEVIS WITH CLIPS TO ISO 8140 STEEL/STAINLESS STEEL - M4 ÷ M20 X 1,5

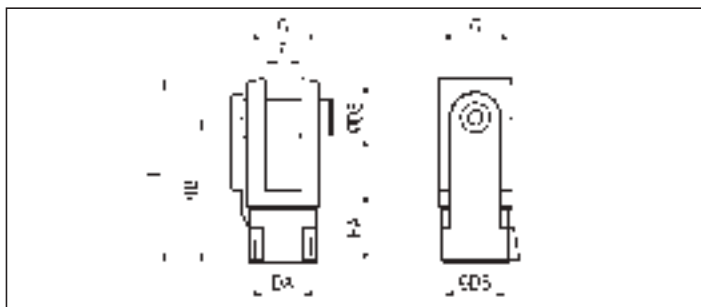

FEMALE PISTON ROD CLEVIS WITH PIN AND SNAP RING TO ISO 8140 - STEEL/STAINLESS STEEL - M4 ÷ M36 X 2

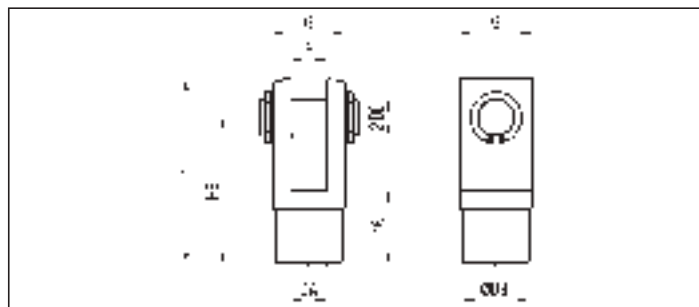

DIMENSIONS AND WEIGHTS

DA	DB	DE	F B12	G	HA	HB	L	WEIGHT (g)	CYLINDER SERIES and Ø				STEEL TYPE WITH CLIPS	STEEL TYPE WITH PIN	STAINLESS STEEL TYPE WITH PIN	
									U-AU	P-AP	BX-ABX-BU	CPU-AX-X-XT				XL
M4	8	4	4	8	8	16	21	10	8-10					FF4		
M6	10	6	6	12	12	24	31	18	12-16					FF6	FFP6	A/FFP6
M8	14	8	8	16	16	32	42	20						FF8	FFP8	A/FFP8
M10x1,25	18	10	10	20	20	40	52	90	25	32	20÷40	32		FF10x1,25	FFP10x1,25	A/FFP10x1,25
M12x1,25	20	12	12	24	24	48	62	130		40	50-63	40		FF12x1,25	FFP12x1,25	A/FFP12x1,25
M16x1,5	26	16	16	32	32	64	83	330		50-63	80	50-63		FF16x1,5	FFP16x1,5	A/FFP16x1,5
M20x1,5	34	20	20	40	40	80	105	650			100	80-100		FF20x1,5	FFP20x1,5	A/FFP20x1,5
M27x2	48	30	30	55	54	110	148	2100					125		FFP27x2	A/FFP27x2
M36x2	60	35	35	70	72	144	188	3900					160-200		FFP36x2	A/FFP36x2
M42x2	70	40	40	85	84	168	232	5300					250		FFP42x2	
M48x2	82	50	50	96	96	192	265	7900					320		FFP48x2	

SELF-LUBRICATING PISTON ROD EYE TO DIN ISO 12240 STANDARD - STEEL

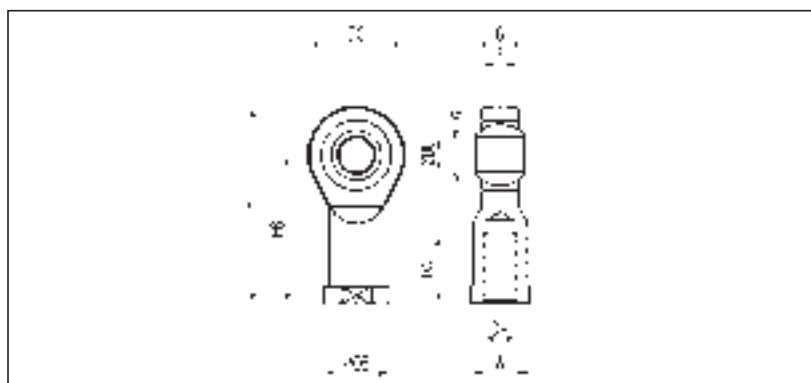

DIMENSIONS AND WEIGHTS

DA	DB	DC H7	DE	F	G	HA	HB	L	W	α	WEIGHT (g)	CYLINDER SERIES and Ø				STEEL TYPE
												U-AU	P-AP	BX-ABX-BU	CPU-AX-X-XT	
M4	11	18	5	6	8	10	27	36	9	13	18	8-10				FF4/SS*
M6	13	20	6	6,75	9	12	30	40	11	13	26	12-16				FF6/SS*
M8	16	24	8	9	12	16	36	48	14	14	46	20				FF8/SS*
M10x1,25	19	28	10	10,5	14	20	43	57	17	13	76	25	32	20÷40	32	FF10x1,25/SS*
M12x1,25	22	32	12	12	16	22	50	66	19	13	110		40	50-63	40	FF12x1,25/SS*
M16x1,5	27	42	16	15	21	28	64	85	22	15	220		50-63	80	50-63	FF16x1,5/SS*
M20x1,5	34	50	20	18	25	33	77	102	30	14	409			100	80-100	FF20x1,5/SS*
M27x2	50	70	30	25	37	51	110	145	41	17	1200				125	FF27x2/SS
M36x2	58	80	35	28	43	56	125	165	50	16	1600				160-200	FF36x2/SS
M42x2	65	91	40	33	49	60	142	187	55	17	2400				250	FF42x2/SS
M48x2	75	117	50	45	60	65	160	218	65	12	5000				320	FF48x2/SS

SELF-ALIGNING ROD COUPLER - ZINC-PLATED STEEL

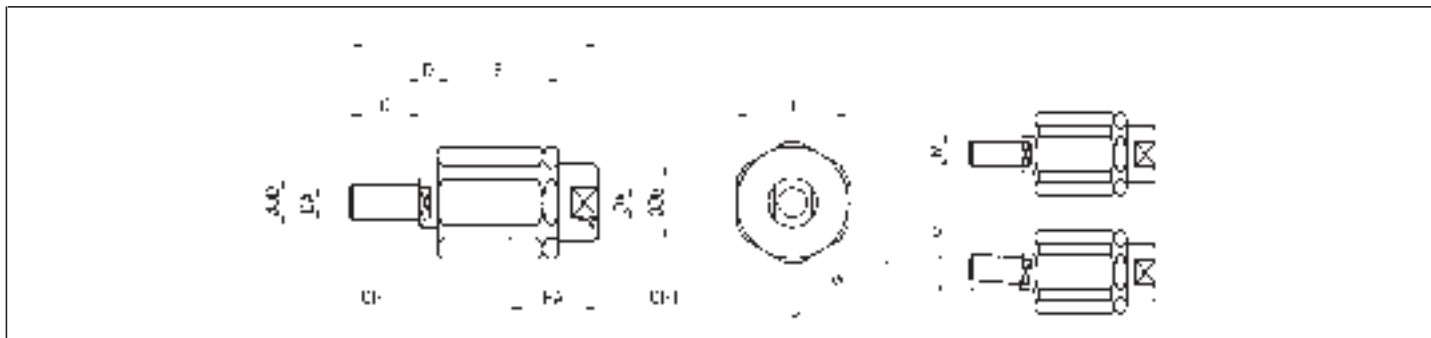

DIMENSIONS AND WEIGHTS

DA	C	CH	CH1	D	DB	DD	E	H	HA	I	L	M	α	WEIGHT (g)	CYLINDER SERIES and Ø				TYPE	
															U	P	BX-BU	CPU-X-XT		XL
M6	11	5	7	2,5	8,5	6	17,5	14,5	12,5	13	35	1	6	25	12-16					FF6/SA
M8	21	7	11	5	12,5	8	26,5	19	16	17	57	2	8	60	20					FF8/SA
M10x1,25	20	12	19	7,5	22	14	35	32	22	30	71,5	2	8	220	25	32	20÷40	32		FF10x1,25/SA
M12x1,25	24	12	19	7,5	22	14	35	32	22	30	75,5	2	8	230		40	50-63	40		FF12x1,25/SA
M16x1,5	32	20	27	10	32	22	53	45	30	41	104	2	6	660		50-63	80	50-63		FF16x1,5/SA
M20x1,5	40	20	27	10	32	22	53	45	37	41	119	2	6	700			100	80-100		FF20x1,5/SA
M27x2	54	24	54	10	57	32	60	70	48	65	147	2	8	2600					125	FF27x2/SA
M36x2	72	32	54	15,5	57	39	77	75	68	70	190	2	8	3110					160-200	FF36x2/SA

FEMALE PISTON ROD CLEVIS WITH CLIPS FOR CYLINDER SERIES HB TO DIN 71752 STANDARD - STEEL

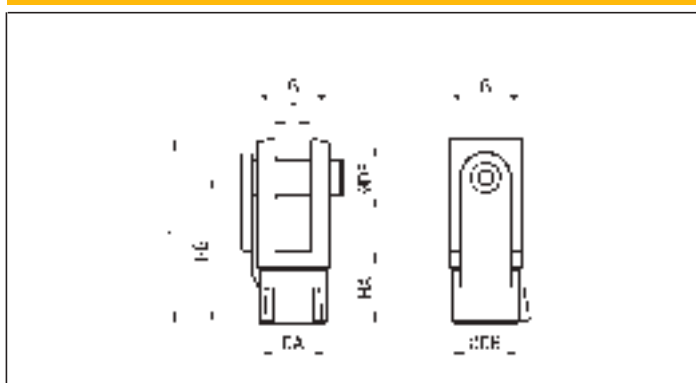

DIMENSIONS AND WEIGHTS

DA	DB	DE	F B12	G	HA	HB	L	WEIGHT (g)	CYLINDER SERIES HB	TYPE WITH CLIPS
									Ø	
M6	10	6	6	12	12	24	31	18	20	FF6
M8	14	8	8	16	16	32	42	42	27	FF8
M10	18	10	10	20	20	40	52	90	35-40	HB/FF10
M12	20	12	12	24	24	48	62	130	50	HB/FF12
M14	24	14	14	27	28	56	72	230	58	HB/FF14
M16	26	16	16	32	32	64	83	330	70	HB/FF16
M18	26	16	16	32	32	64	83	330	85	HB/FF18
M20	34	20	20	40	40	80	105	650	100	HB/FF20

1

**FEMALE PISTON ROD CLEVIS WITH CLIPS
TO EX CNOMO 06 07 14 STANDARD - STEEL - M 10 ÷ M 27 X 2**

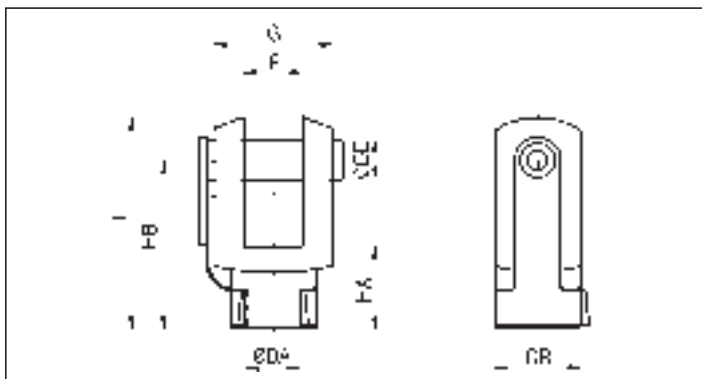

**FEMALE PISTON ROD CLEVIS WITH PIN AND SNAP RING
TO EX CNOMO 06 07 14 STANDARD - STEEL - M 10 ÷ M 36 X 2**

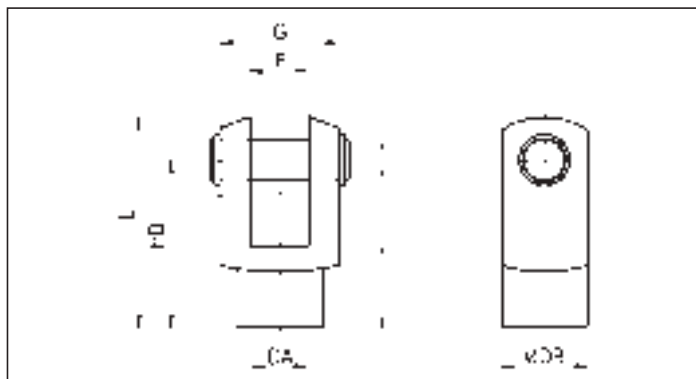

DIMENSIONS AND WEIGHTS

DA	DB	DE	F B12	G	HA	HB	L	WEIGHT (g)	CYLINDER SERIES CX Ø	TYPE WITH CLIPS	TYPE CON PIN
M10	18	8	11	22	20	36	45	80	32	CX/FF10	CX/FFP10
M16x1,5	26	12	18	36	26	51	64	210	40-50	CX/FF16x1,5	CX/FFP16x1,5
M20x1,5	34	16	22	45	30	63	80	440	63-80	CX/FF20x1,5	CX/FFP20x1,5
M27x2	42	20	30	63	45	85	105	910	100-125	CX/FF27x2	CX/FFP27x2
M36x2	50	25	40	80	75	115	140	1800	160-200	-	CX/FFP36x2

MALE PISTON ROD CLEVIS TO ex CNOMO 06 07 15 STANDARD - STEEL

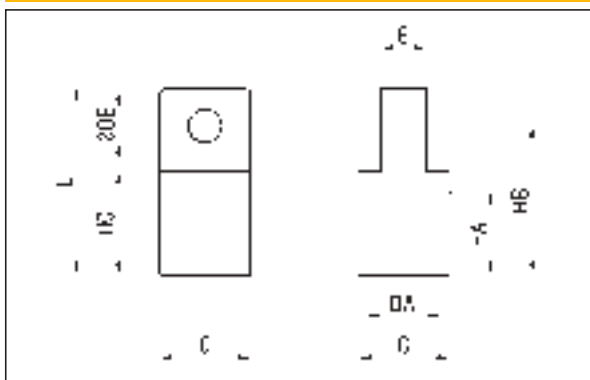

DIMENSIONS AND WEIGHTS

C	DA	DE H8	E f8	HA	HB H13	HC	L	WEIGHT (g)	CYLINDER SERIES CX Ø	TYPE
22	M10	8	11	20	36	25	45	30	32	CX/FM10
32	M16x1,5	12	18	30	51	34	64	100	40-50	CX/FM16x1,5
36	M20x1,5	16	22	36	63	41	80	140	63-80	CX/FM20x1,5
45	M27x2	20	30	50	85	58	105	320	100-125	CX/FM27x2
63	M36x2	25	40	70	115	81	140	870	160-200	CX/FM36x2

**ROD NUT
STEEL/STAINLESS STEEL**

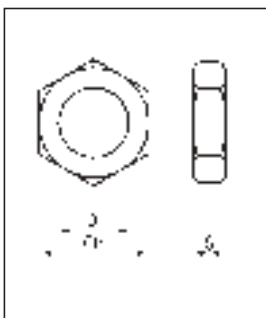

DIMENSIONS AND WEIGHTS

DI	CH	S	WEIGHT (g)	CYLINDERS SERIES and Ø							TYPE STEEL	TYPE STAINLESS STEEL	
				U-AU	P-AP	BX-ABX-BU	CX	CPU-AX-X-XT	XL	B+NIPLO			
M4	7	3	0,8	8-10								DST4	DSTI4
M6	10	4	1,48	12-16						12-16		DST6	DSTI6
M8	13	5	4	20						20-25		DST8	DSTI8
M10x1,25	17	6	8,6	25	32	20÷40				32-40		DST10x1,25	DSTI10x1,25
M10	17	6	8,6				32					DST10	DSTI10
M12x1,25	19	7	12,1		40	50-63		40		50-63		DST12x1,25	DSTI12x1,25
M16x1,5	24	8	20,1		50-63	80	40-50	50-63	50-63	G50÷80		DST16x1,5	UPDT16
M20x1,5	30	9	36,3			100	63-80	80-100	80-100	100		DST20x1,5	DSTI20x1,5
M27x2	41	12	90				100-125			125		DST27x2	DSTI27x2
M36x2	55	15	190				160-200			160-200		DST36x2	DSTI36x2
M42x2	65	16	307							250		DST42x2	
M48x2	75	18	460							320		DST48x2	

DESCRIPTION

Magnetic sensors series "FM" allow to detect the magnetic piston position inside the cylinders. The magnetic field generated by the magnet is used to signal electrical circuits as required. It's possible to choose between two types of switches:

- Reed switch (electromechanical switch that can work with both AC or DC circuits)
- Magnetoresistive (electronic switch suitable for DC circuit only).

Magnetic sensors have a LED that signals the insertion as standard and the type "FM100/EX" comply with ATEX directive, categories 1GD and 3GD.

WARNINGS

The magnetic sensor is a switch that has to be assembled in series with a load (inductive, resistive or capacitive). Use the shortest possible connection cable to reduce self-capacitance to a minimum. In borderline cases, measures should be taken to cancel the effect of cable capacitance using a repetition relay (4 W) in series. Avoid close proximity to external magnetic fields such as electric motors or large iron masses, as they could affect the switch. The sensors are able to detect a magnetic signal at speeds of the piston up to 1 m/s.

MAGNETIC SENSORS SERIES FM100

TECHNICAL DATA

TYPE	FM100	FM100R	FM100N	FM100E	FM100EN
	FM100/C*	FM100R/C	FM100N/C*	FM100E/C	FM100EN/C
Working temperature	-10 ÷ +70 °C				
Protection class	IP 67				
Model	REED SWITCH			HALL EFFECT	
Contacts	N.O.		N.C.	PNP	NPN
Voltage AC/DC	3 ÷ 230 V 3 ÷ 30 V*	3 ÷ 30 V	5 ÷ 120 V 3 ÷ 30 V*	6 ÷ 30 V	
Max voltage drop	3 V	-	3,5 V	1 V	
Max exchange current	500mA 200mA*	200mA	100 mA	200mA	
Max power	10 W 6 W*	6 W	10 W	6 W	
Operating frequency	200 Hz	500 Hz	200 Hz	200 KHz	

MATERIALS

Body	Polyamide, stainless steel and brass
Cable	Polyvinylchloride
Connector	Polyurethane and gold-plated brass

FM100 - FM100R - FM100N - FM100E - FM100EN

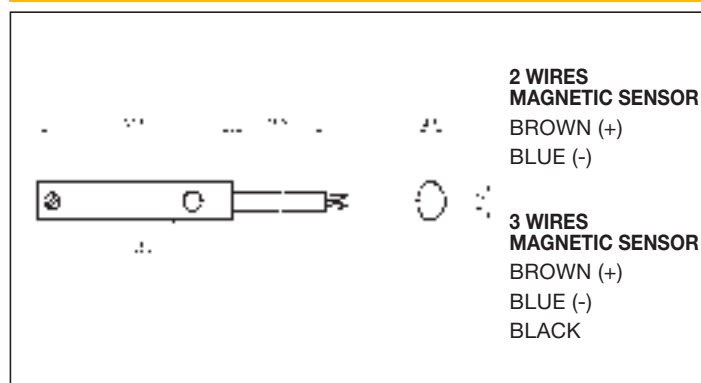

DESCRIPTION	WEIGHT (g)	TYPE
N.O. reed switch with LED and 2 wires cable 3 m length	33	FM100
N.O. reed switch with LED and 3 wires cable 3 m length	33	FM100R
N.C. reed switch with LED and 2 wires cable 3 m length	33	FM100N
Hall effect switch version PNP with LED and 3 wires cable 3 m length	37	FM100E
Hall effect switch version NPN with LED and 3 wires cable 3 m length	37	FM100EN



FM100/C - FM100R/C - FM100N/C - FM100E/C - FM100EN/C

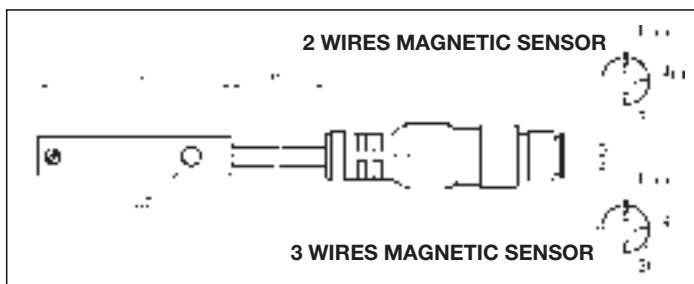

DESCRIPTION	WEIGHT (g)	TYPE
N.O. reed switch with LED and 2 wires ring nut connector M8	45	FM100/C
N.O. reed switch with LED and 3 wires ring nut connector M8	45	FM100R/C
N.C. reed switch with LED and 2 wires ring nut connector M8	45	FM100N/C
Hall effect switch version PNP with LED and 3 wires ring nut connector M8	49	FM100E/C
Hall effect switch version NPN with LED and 3 wires ring nut connector M8	49	FM100EN/C

EXTENSION WITH FEMALE CONNECTOR M8

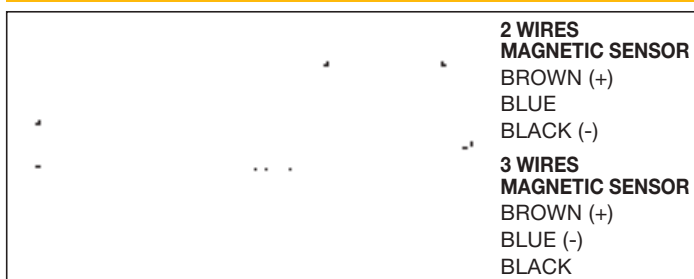

DESCRIPTION	WEIGHT (g)	L (m)	TYPE
Extension 3 m length with female connector M8	40	3	CNT3
Extension 5 m length with female connector M8	60	5	CNT5

MAGNETIC SENSORS SERIES FM157

TECHNICAL DATA

TYPE	FM157 - FM157/C	FM157E - FM157E/C
Working temperature	-10 ÷ +70 °C	
Protection class	IP67	
Model	REED SWITCH	HALL EFFECT
Contacts	N.A.	PNP
Voltage AC/DC	3 ÷ 250 V	6 ÷ 30 V
Max voltage drop	3 V	1 V
Max exchange current	1500 mA	250 mA
Max power	10 W	6 W
Operating frequency	500 Hz	200 KHz



MATERIALS

Body	Polyamide, stainless steel and brass
Cable	Polyvinylchloride
Connector	Polyurethane and gold-plated brass

FM157/C - FM157E/C

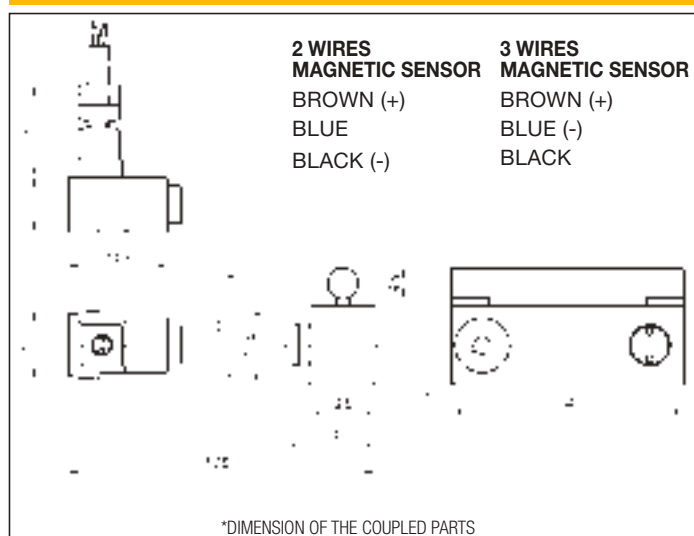

FM157 - FM157E

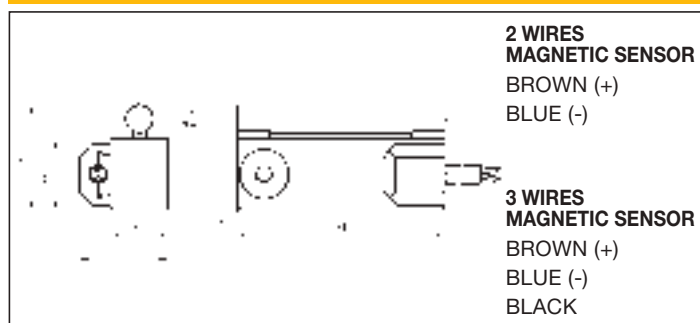

DESCRIPTION	WEIGHT (g)	TYPE
Reed switch with LED and 2 wires cable 2,5 m length	55	FM157
Hall effect switch version PNP with LED and 3 wires cable 2,5 m length	58	FM157E

DESCRIPTION	WEIGHT (g)	TYPE
Reed switch with LED, connector M8 and 2 wires cable 2,5 m length	58	FM157/C
Hall effect switch version PNP with LED, connector M8 and 3 wires cable 2,5 m length	61	FM157E/C

ELECTRIC CIRCUIT REED SWITCH

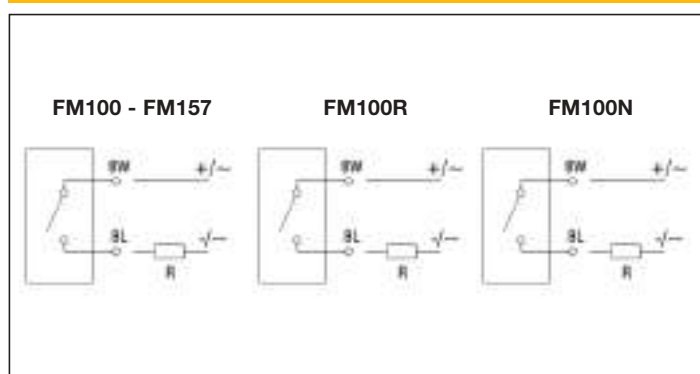

ELECTRIC CIRCUIT HALL EFFECT SWITCH

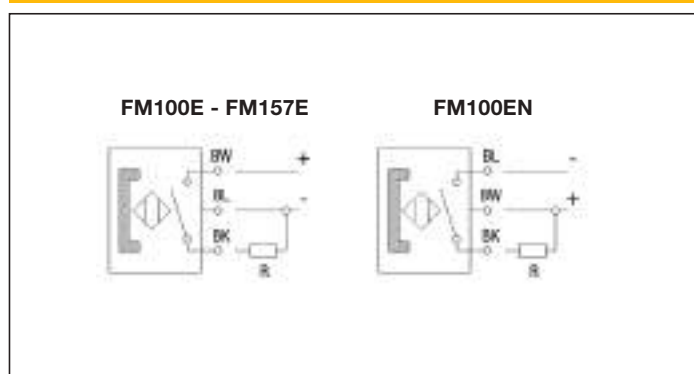

POSITIONING INSIDE "TEE-SLOT"

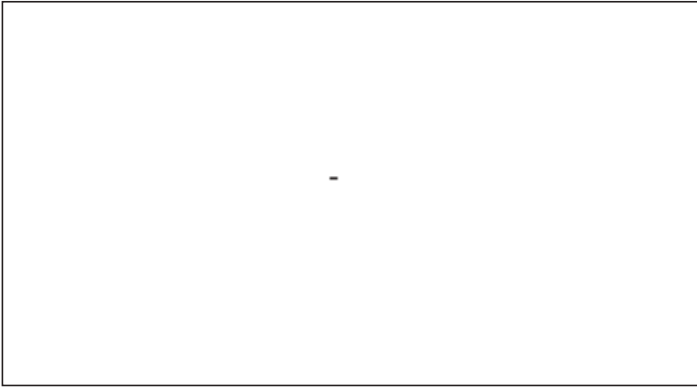

FIXING ADAPTER - PLASTIC - SQB12 - SQB

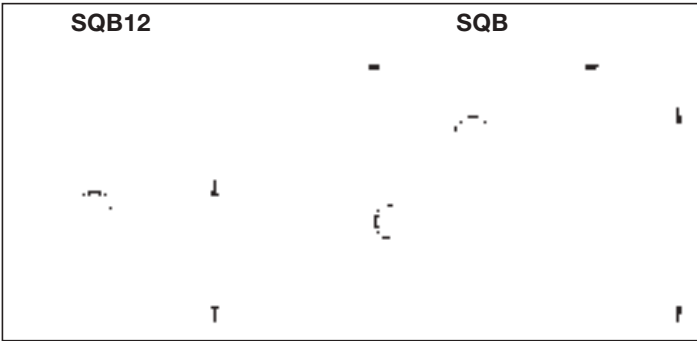

SENSOR FIXING BRACKETS - ALUMINIUM- SQZ

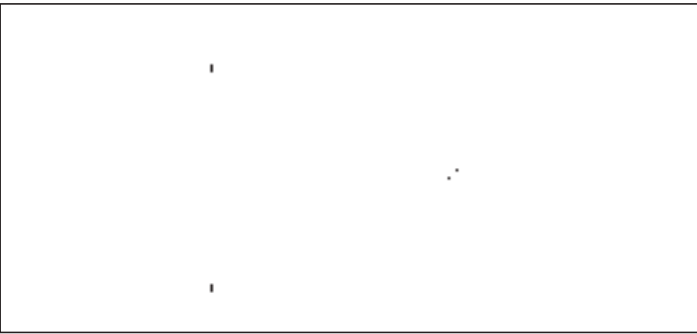

SENSOR FIXING BRACKETS WITH TIE RODS - AISI 304 STAINLESS STEEL - IFS



MAXIMUM DIMENSIONS WITH CYLINDERS SERIES B

H	L	Ø CYLINDER	TYPE
27	-	12	SQB12
32	36	16	SQB
37	41	20	
49	53	32	
58	61	40	
68	73	50	
81	89	63	
101	107	80	
124	132	100	

MAXIMUM DIMENSIONS WITH CYLINDERS SERIES Z

L	Ø CYLINDER	TYPE
36,6	18	SQZ
48,6	25	
58,6	32	
69,6	40	
84,6	50	
99,6	63	

P.S.: Sensor fixing brackets type "SQZ" can be used to mount the magnetic sensors "FM100" in the swallow-tailed slots.

P.S.: For Ø 18 it is not possible to mount the magnetic sensors in the opposite side of the yoke.

MAXIMUM DIMENSIONS WITH CYLINDERS SERIES AX

Ø CYLINDER	TYPE
32	IFS1
40	
50	
63	
80	
100	IFS2
125	
160	
200	

1

FIXING BRACKETS - PLASTIC - FG

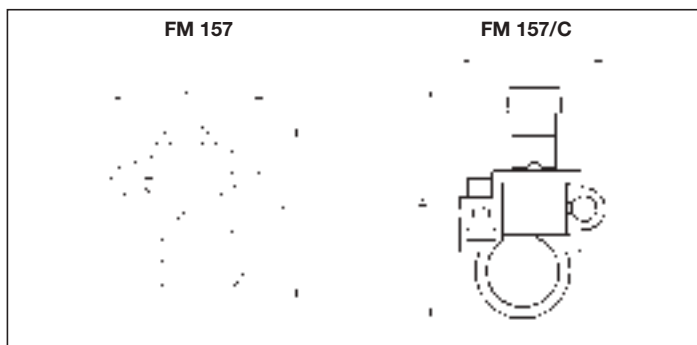

MAXIMUM DIMENSIONS WITH CYLINDERS

H1	H	L	CYLINDER SERIES and Ø		TYPE*
			U	P	
26	38	23	8	-	FG/050
28	40	28	10	-	FG/051
31	42	27	12	-	FG/052
33	45	28,5	16	-	FG/053
38	52	32	20	-	FG/054
43	58	32	25	-	FG/055
51	65	32	-	32	FG/056
60	73	32	-	40	FG/057
70	83	32,5	-	50	FG/058
84	97	32,5	-	63	FG/059

* Supplied with the adapter for "FM100".

FIXING BRACKETS - ALUMINIUM - ST

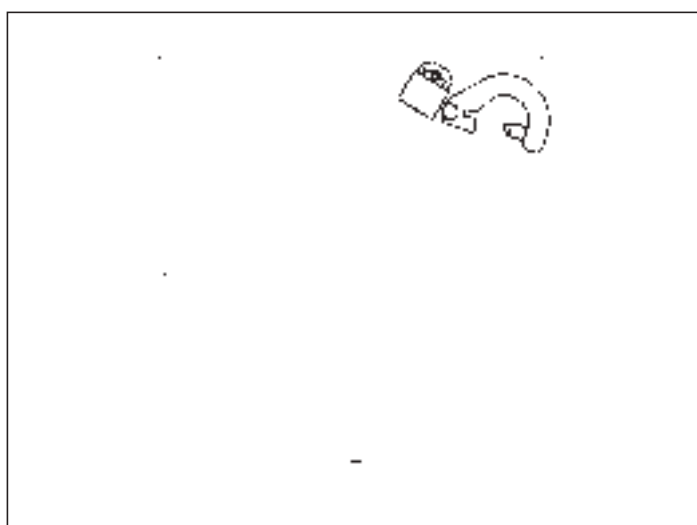

MAXIMUM DIMENSIONS WITH CYLINDERS

H	L	CYLINDER SERIES and Ø			TYPE*
		XL	CPU	CX	
33	33	-	32	32	ST3456
37,5	33	-	40	40	
40	35	-	50	50	
49	39	-	63	63	
56	48	-	80	80	SQ32-40A
61	54	-	100	100	
71	69	125	-	125	SQ80-100A
92	90	160	-	160	
120	118	200	-	200	

* Supplied with the adapter for "FM100".

FIXING BRACKETS - ALUMINIUM - ST

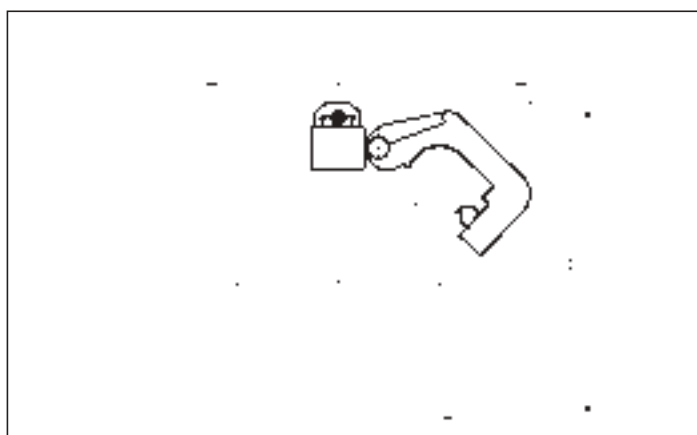

MAXIMUM DIMENSIONS WITH CYLINDERS SERIES CPA - WR

H	L	Ø CYLINDER	TYPE*
55	63	32	ST34
65	60	40	
77	72	50	ST56
87	82	63	
102	101	80	ST80
120	117	100	
147	131	125	ST102



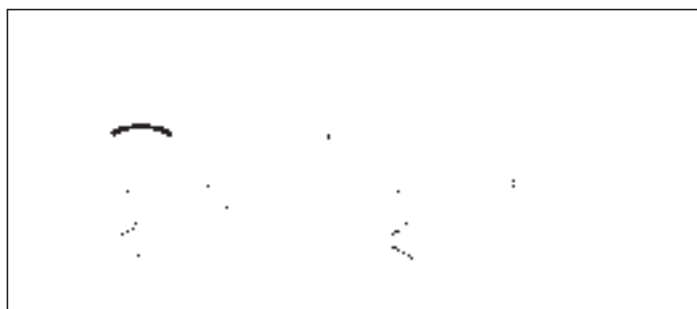

* Supplied with the adapter for "FM100".

ADAPTER FOR SERIES FM100 (SUPPLIED WITH FIXING BRACKETS)



MAGNETIC SENSORS SERIES FM100/EX

TECHNICAL DATA

TYPE	FM100/EX 3GD	FM100/EX 1GD
Working temperature	-20 ÷ +60 °C	-25 ÷ +70 °C
Protection class	P 65 / IP 67	
Model	HALL EFFECT	
Contacts	PNP N.A.	*
Voltage DC	10 ÷ 30 V	8.2 V
Max voltage drop	2,5 V	-
Max exchange current	100 mA	-
Operating frequency	6000 Hz	2000 Hz
Marking	 II 3D Ex tc IIC T125 °C Dc X  II 3G Ex nA IIC T4 Gc X	 II 1D Ex ia IIC T135 °C Da  II 1G Ex ia IIC T4 Ga

* Connection to certified intrinsically safe electric circuits with maximum values:
U=15V, I=50mA, P=120mW

MATERIALS

Body	Polyamide
Cable	PVC
Eccentric fixing	Stainless steel

FM100/EX 1GD - FM100/EX 3GD

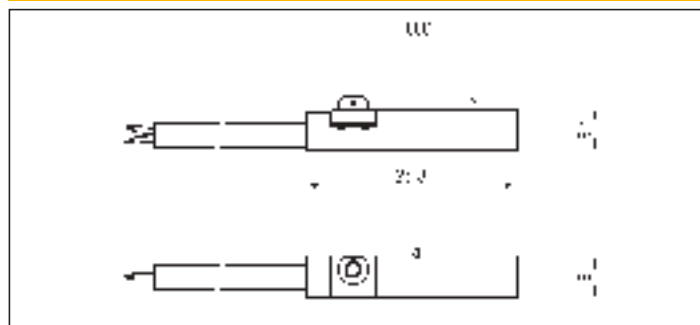

DESCRIPTION	WEIGHT (g)	TYPE
Magneto-resistive 3GD switch, version PNP with LED and 3 wires cable 6 m length	104	FM100/EX 3GD
Magneto-resistive 1GD switch, version PNP with LED and 2 wires cable 6 m length	86	FM100/EX 1GD

FIXING BRACKETS

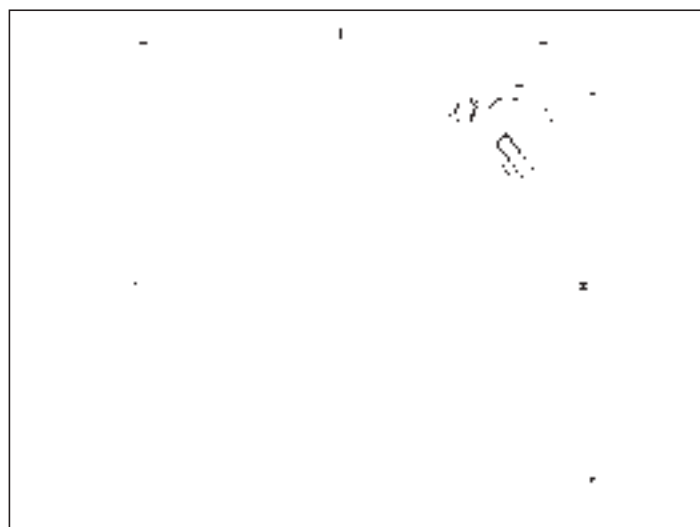

MAXIMUM DIMENSIONS WITH CYLINDERS

L	H	CYLINDER SERIES and Ø		TYPE
		XL	CX	
135	131	125		FS125
170	166	160		FS162
210	205	200		



ELECTRIC CIRCUIT HALL EFFECT SWITCH

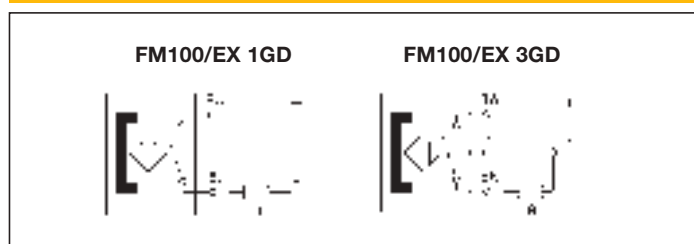

TEE-SLOTS

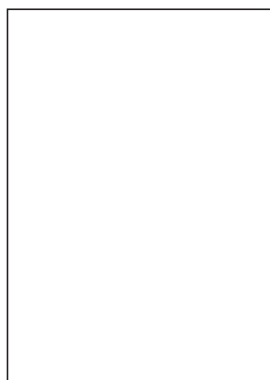

PROTECTION FM100/EX 3GD



FIXING BRACKETS

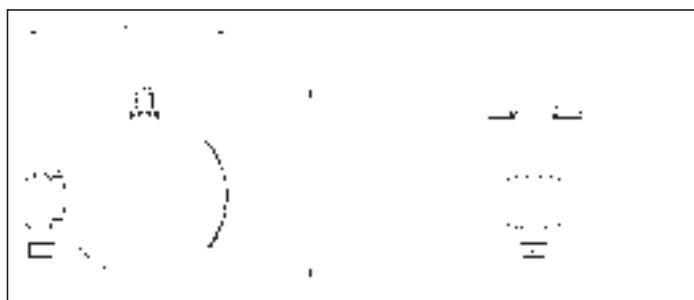

MAXIMUM DIMENSIONS WITH CYLINDERS

L	H	CYLINDER SERIES and Ø		TYPE
		U	P	
18	17	8	-	F1
20	19	10	-	
22	21	12	-	
26	25	16	-	F2
30	29	20	-	F3
35	34	25	-	
42	41	-	32	F4
50	49	-	40	
61	60	-	50	F5

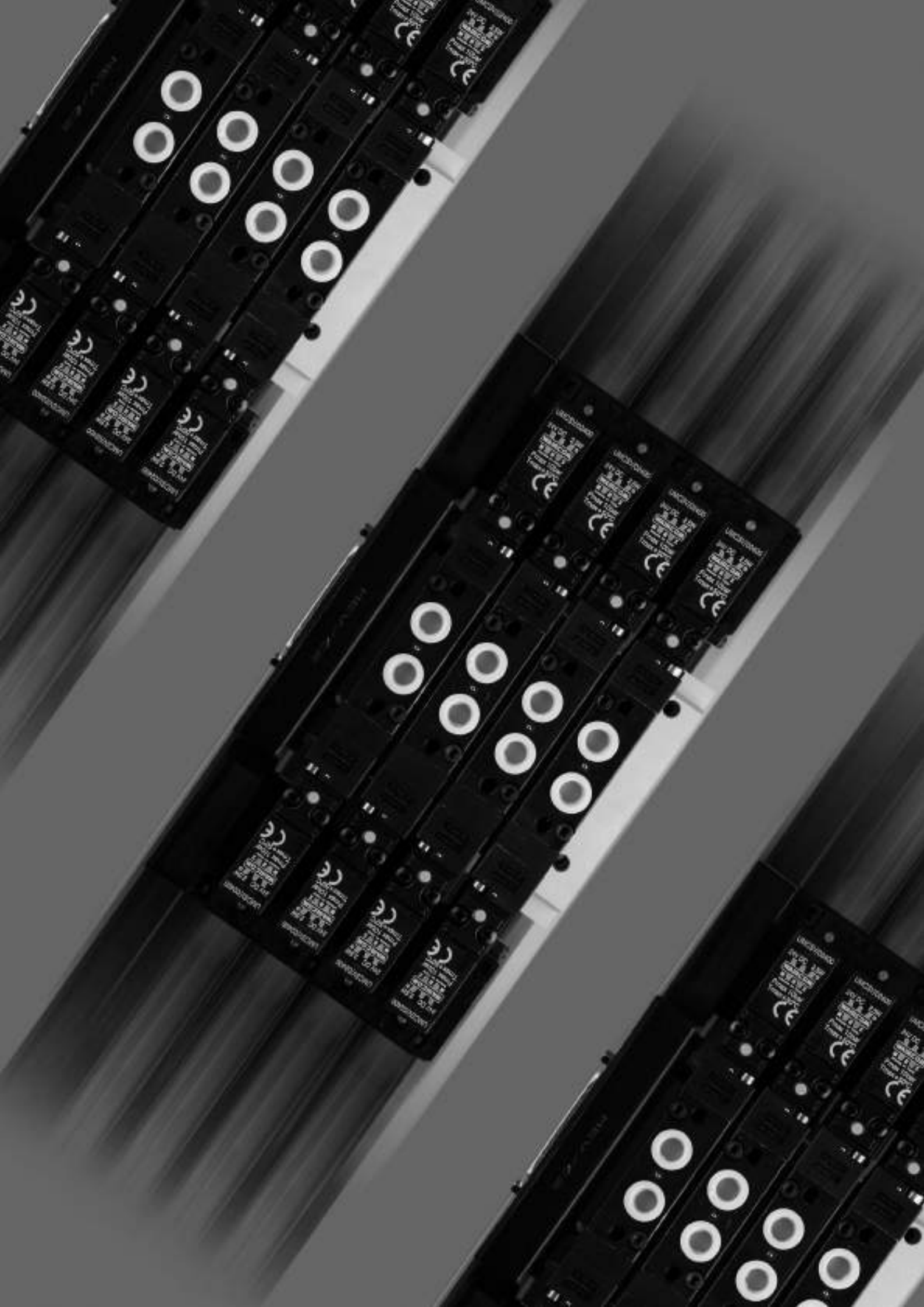

Series DM	
Direct acting solenoid valves 10 mm	page 2.2
Series UM	
Direct acting solenoid valves 15 mm	page 2.5
Series CN	
Connectors for solenoid valves 10 mm and 15 mm	page 2.6
Series UL	
Direct acting solenoid valves side 32 mm	page 2.8
Accessories: bases	page 2.10
Series C/	
Direct acting solenoid valves with sleeve Ø 9 mm	page 2.12
Series USB/USBG	
Coils for solenoid valves with sleeve Ø 9 mm	page 2.17
Series USBG2/EX	
Coils for solenoid valves side 30 mm with sleeve Ø 9 mm conform to ATEX 2GD directive	page 2.17
Series MEK192/N	
Connectors DIN 43650-C for solenoid valves side 15 mm series UM	page 2.18
Series USR102/N9	
Connectors DIN 43650-B for coils side 22 mm series USB and series WE (3A)	page 2.18
Series ULR1B	
Connectors DIN 43650-A for solenoid valves side 30 mm series UL and coils series USBG and series WE (2A, 5A)	page 2.18
Series SK	
Spool compact valves pilot and solenoid actuated G1/8	page 2.19
Accessories: bases G 1/8	page 2.28
Series MEV	
Spool compact valves pilot and solenoid actuated G 1/8 and to ISO 15407-2 standard (VDMA 24563) size 02	page 2.30
Accessories: bases G 1/8	page 2.35
single and manifold bases to ISO 15407-2 standard (VDMA 24563) size 02	page 2.40
multi-pin connection with solenoid valves versions MEVX 8 and MEVX 18	page 2.42
Assembling examples: Multi-pin connection with solenoid valves versions MEVX 8 and MEVX 18	page 2.44
Series MEK	
Spool compact valves pilot and solenoid actuated G 1/8 - G 1/4	page 2.46
Accessories: bases G 1/8	page 2.50
bases G 1/4	page 2.56
Series EK	
Spool valves pilot and solenoid actuated G 1/8 - G 1/4 - G 1/2	page 2.57
Accessories: bases G 1/8	page 2.62
bases G 1/4	page 2.69
Series EK30 G1/4 5 port	page 2.70
90° solenoid actuated valves	page 2.74
Series UK	
Poppet valves pilot and solenoid actuated G 1/8 - G 1/4 - G 1/2 - G 1	page 2.76
Accessories: bases G 1/8	page 2.81
bases G 1/4	page 2.84
bases G 1/2	page 2.87
Series UDS ISO	
Valves to ISO 5599/1 standard pilot and solenoid actuated sizes 1 - 2 - 3	page 2.90
Accessories: single bases to ISO 5599/1 standard sizes 1-2-3 obtained from drawn light alloy	page 2.97
manifold bases to ISO 5599/1 standard size 1 obtained from die-cast light alloy	page 2.100
manifold bases to ISO 5599/1 standard size 2 obtained from die-cast light alloy	page 2.101
Series UDS CETOP	
Valves to ex CETOP RP 32 P standard pilot and solenoid actuated sizes 05 - 12 - 35	page 2.102
Series W	
Solenoid valves for industrial media G 1/8 ÷ G 2	page 2.107
Series EV	
Valves for vacuum solenoid pilot assisted actuated G 1/8 ÷ G 2	page 2.110
Series VM	
Vacuum generators G 1/8 ÷ G 1	page 2.112

series DM

Direct acting solenoid valves 10 mm

DESCRIPTION

The direct acting solenoid valves series "DM" are produced in the 3/2 N.C. pneumatic function with the interface to ISO 15218 and in the 3/2 N.O. and 2/2 N.C. pneumatic functions with not standardized interface. These valves can be used with all the fluids that can match the constructive materials. The versions with nominal diameter of 1.1 mm are equipped with "CRP" (Power Reduction Circuit, see below). They can comply with ATEX directive, 3GD category, upon request.

TECHNICAL DATA

Nominal diameter	0,7 mm (standard coil)	1,1 mm (coil with "CRP")
Flow rate 1-2 at 6 bar $\Delta p=1$	14 NI/min	24 NI/min
Flow rate 2-3 at 6 bar $\Delta p=1$	22 NI/min	30 NI/min
Interface	to ISO 15218 or not standardized	
Operating pressure	0 ÷ 7 bar	
Working temperature	-5 ÷ +50 °C	
Fluid	Compressed air, filtered, continuous lubricated, unlubricated or dry lubricated	
Max. operating frequency	≤40 Hz	
Coil	Adjustable	
Voltages	DC: 6 - 12 - 24 V AC: 24 V	DC: 12 - 24 V
Power consumption	DC: 1.3 W	DC: 3.5 W - 0.9 W
Voltage tolerance	-5 ÷ +10%	
Protection class	IP 51 - IP 65 (only versions with embedded cables)	
Insulation class	F (155 °C)	
Duty cycle	Continuous rating (ED 100%)	
Energized	Solenoid with response time = 8 ms	
De-energized	Mechanical spring with response time = 10 ms	
Electric connector	With 90° and in-line connectors: series CN - see chapter connectors on page 2.6	

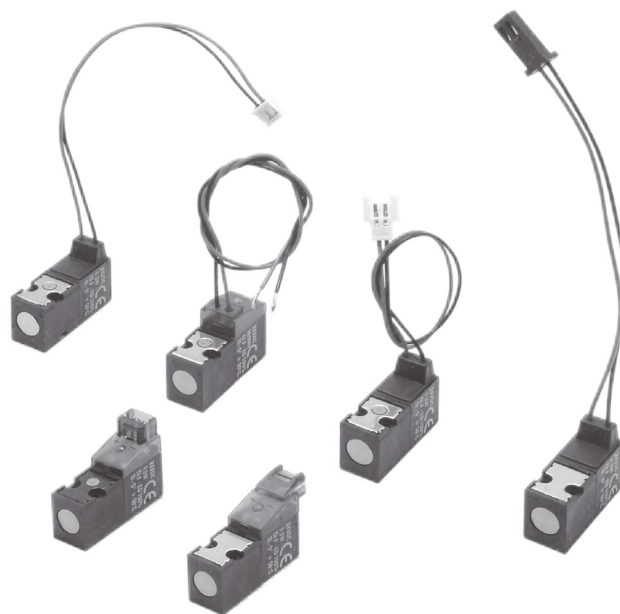

MATERIALS

Core	Stainless steel
Body and manual override	PA and POM
Springs	Stainless steel
Seals	NBR and FKM rubber

ORDER KEY

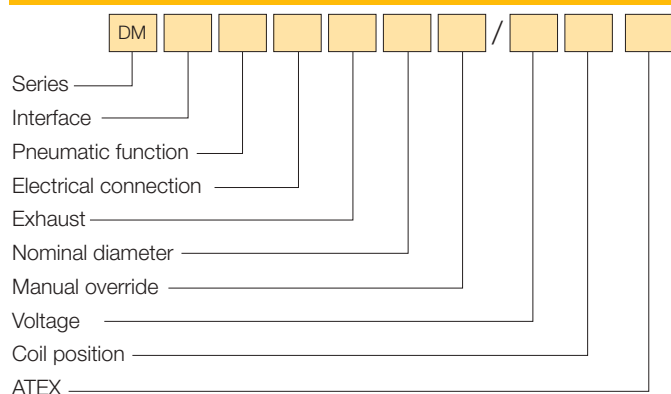

POWER REDUCTION CIRCUIT (CRP)

The small size and the high power required to switch the solenoid valves with a nominal diameter of 1.1 mm, would not allow the coil to dissipate the heat it generates. The power reduction circuit ("CRP") prevents this effect. When energized, the coil produces an output of 3.5 W for the short period of 15 ms needed to switch the valve. Subsequently, the "CRP" acts by reducing the coil power to 0.35 W while maintaining the solenoid valve switched to the end of insertion. At full capacity the entire circuit, including LED indicators, absorbs 0.9 W.

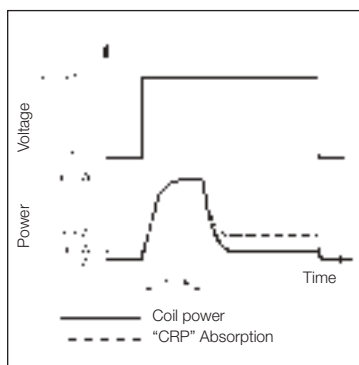

ORDER EXAMPLE

1 0 mm valve with not standardized interface, 3/2 N.C., with 90° connector, without LED, free exhaust, nominal diameter 0.7 mm, monostable push button and 24 V DC coil: **DMC4L/02400**

* Only with: in-line connector + LED, or 90° connector + LED

** Only with cable 300 mm length

INTERFACE

Not standardized | ISO 15218 (only 3/2 N.C.)

PNEUMATIC FUNCTION

2C 2/2 N.C. **C** 3/2 N.C.
A 3/2 N.O.

ELECTRICAL CONNECTION

- 90° connector + bipolar LED and diode
- Cable 300 mm length
- In-line connector + bipolar LED and diode
- 90° connector
- In-line connector

OPTIONS

- Cable 100 mm length + Molex® male connector code 51 006-0200
- Cable 100 mm length + Tyco® MODU II connector code 280358-0
- Cable 100 mm length + Molex® female connector code 51 065-0200
- 88 Pair of solenoid valves with cables 100 mm length + Molex® single female connector code 51 065-0400

EXHAUST

Channeled (standard) | **L** Free (with not standardized interface 3/2 N.C.)

NOMINAL DIAMETER

0.7 mm (standard) | **B** 1.1 mm (only 12 o 24 V DC + CRP)

MANUAL OVERRIDE

Push monostable (standard) | **1** Manual bistable override
2 Without manual override

VOLTAGE

00600	6V DC	01200	12V DC
02400	24V DC	02450-60	24V AC
01200CRP	12V DC*	02400CRP	24V DC*

COIL POSITION

Standard | **180** Rotated 180°

ATEX**

/EX Consistent with the ATEX directive II 3G c Ex nA IIC T5 Gc -5°C ≤ Ta ≤ 50°C
II 3D c Ex tc IIIC T100°C IP65 Dc

PNEUMATIC FUNCTIONS WITH NOT STANDARDIZED INTERFACE

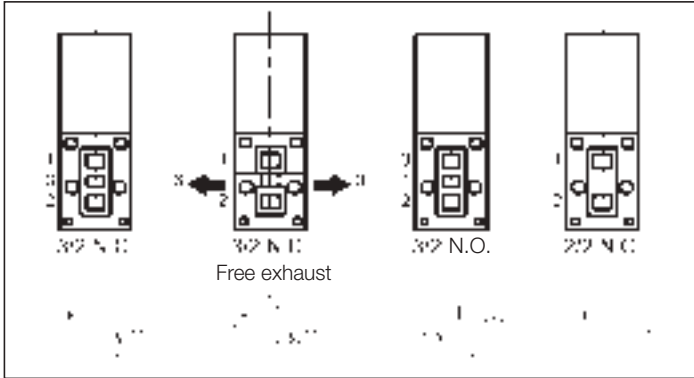

PNEUMATIC FUNCTION WITH INTERFACE TO ISO 15218

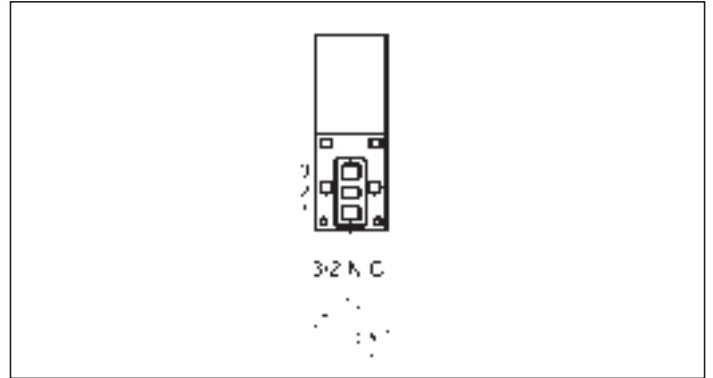

DIMENSIONS

WITH 90° CONNECTOR

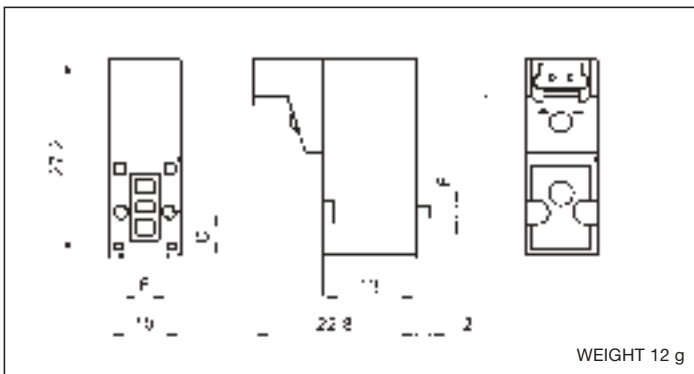

WITH IN-LINE CONNECTOR

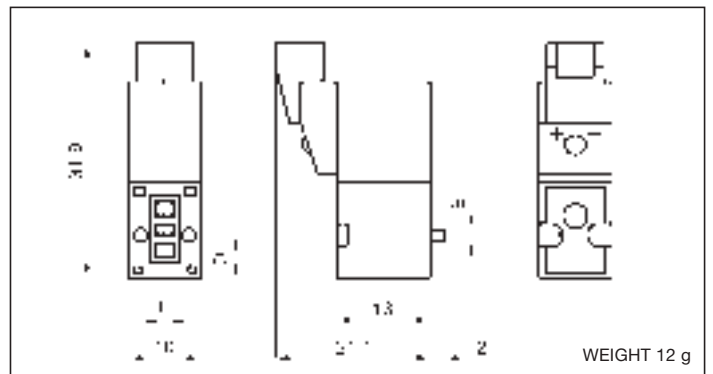

WITH CABLES

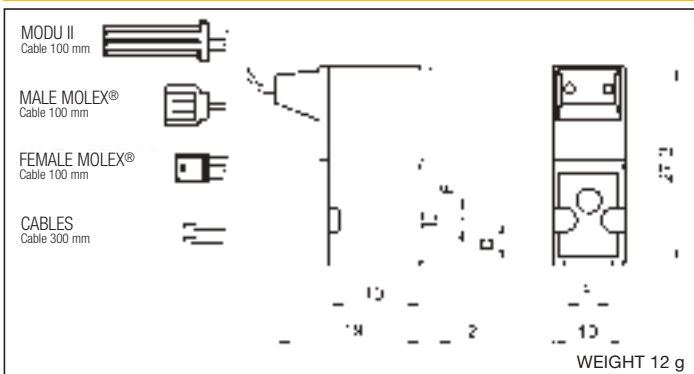

Dimensions	Non-standardized interface	Interface ISO 15218
D	6	6.2
E	M1.7 x 0.35	M1.6 x 0.35
F	6.6	6.8

DIMENSIONS OF THE NOT STANDARDIZED INTERFACE

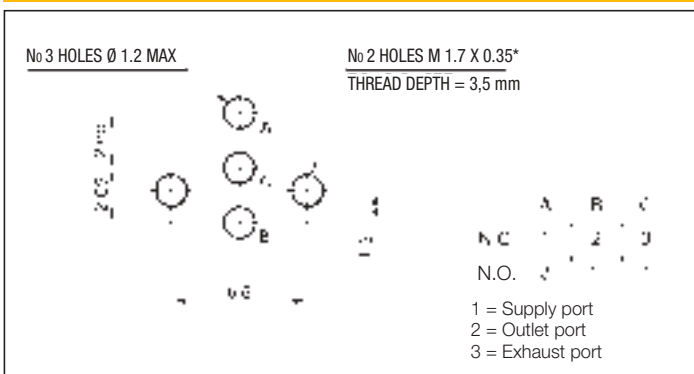

DIMENSIONS OF THE INTERFACE TO ISO 15218

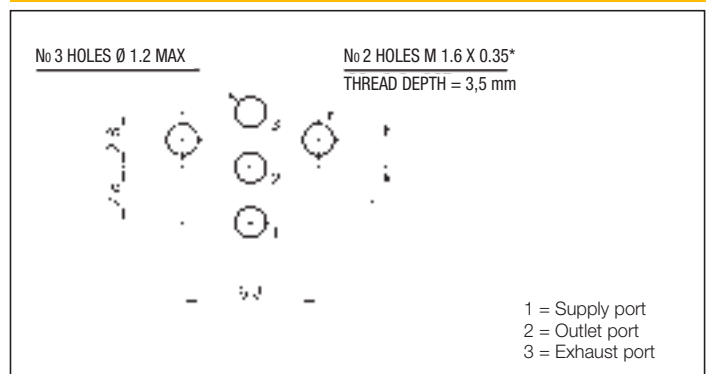

*Self-tapping screws for plastic available. See on page 2.7

*Self-tapping screws for plastic available. See on page 2.7

2

SINGLE BASE WITH NOT STANDARDIZED INTERFACE - DMP5/1

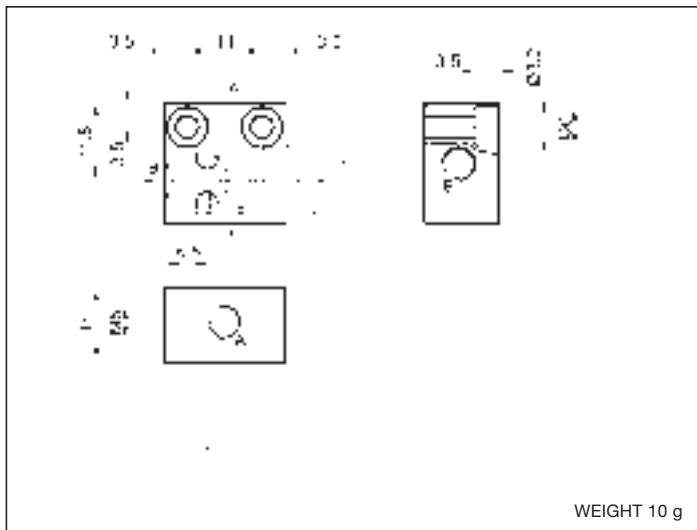

SINGLE BASE WITH INTERFACE TO ISO 15218 - DMIP5/1

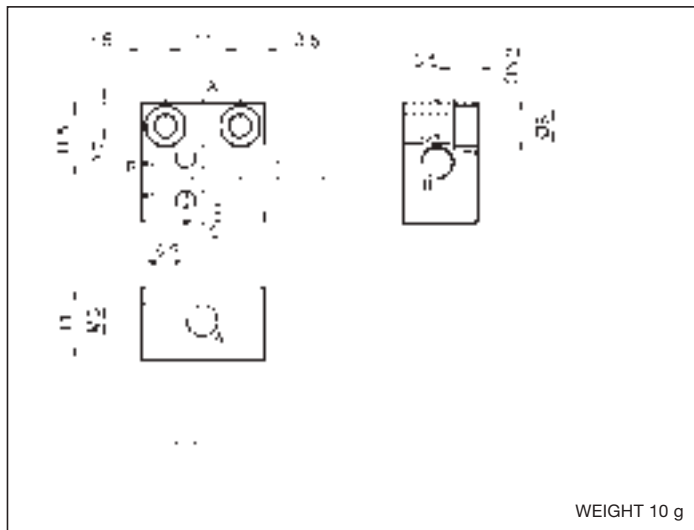

MULTI-STATION BASE WITH NOT STANDARDIZED INTERFACE - DMPM5

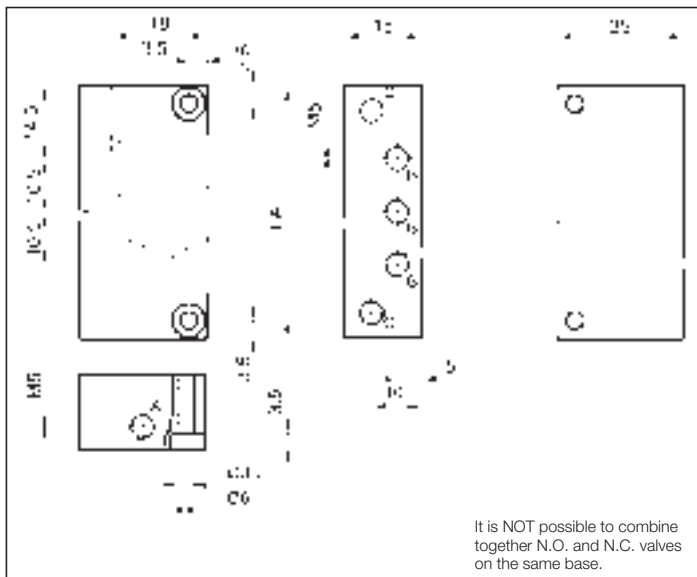

MULTI-STATION BASE WITH INTERFACE TO ISO 15218 - DMIPM5

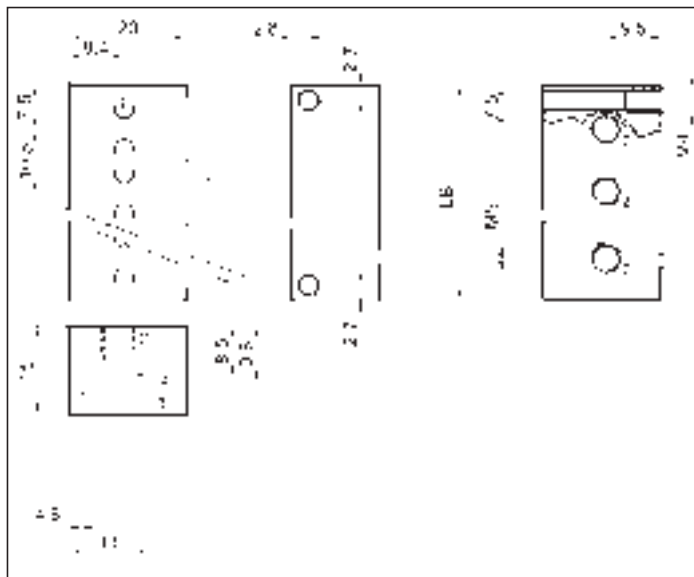

No of stations	2	3	4	5	6	7	8	9	10
LA	39.5	50	60.5	71	81.5	92	102.5	113	123.5
LB	25.5	36	46.5	57	67.5	78	88.5	99	109.5
Weight (g)	43	54	65	76	87	98	109	120	131
TYPE	DMPM5/2	DMPM5/3	DMPM5/4	DMPM5/5	DMPM5/6	DMPM5/7	DMPM5/8	DMPM5/9	DMPM5/10
Weight (g)	22	30	38	46	54	62	70	78	86
TYPE	DMIPM5/2	DMIPM5/3	DMIPM5/4	DMIPM5/5	DMIPM5/6	DMIPM5/7	DMIPM5/8	DMIPM5/9	DMIPM5/10

CLOSING PLATE FOR NOT STANDARDIZED INTERFACE - KIT/PC/DM

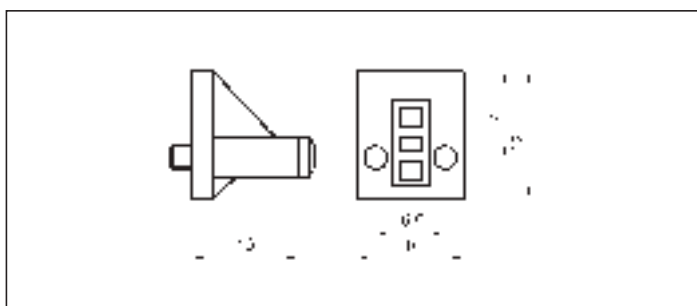

CLOSING PLATE FOR INTERFACE TO ISO 15218 - KIT/PC/DMI

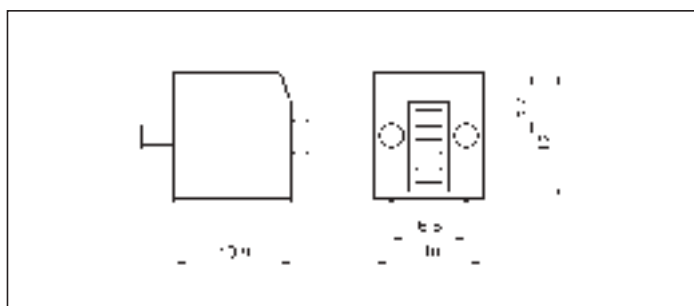

DESCRIPTION

The direct acting solenoid valves series "UM" are produced in the 3/2 and 2/2 N.C. /N.O. pneumatic functions. They are used as power valves if mounted on single and multi-station base, or as control valves if mounted, in the 3/2 pneumatic function, on body valves series "SK", "MEV", "MEK", or "UK". These valves can be used with all the fluids that can match the constructive materials. The multi-station bases support both the 3/2 N.O. than the 3/2 N.C. pneumatic functions. They can comply with ATEX directive, 3GD category, upon request.

TECHNICAL DATA

Nominal diameter	0,8 mm	1.1 mm (standard)	1.6 mm
Flow rate 1 -2 at 6 bar Δp=1	20 NI/min	30 NI/min	50 NI/min
Flow rate 2-3 at 6 bar Δp=1	30 NI/min	30 NI/min	50 NI/min
Operating pressure	0 ÷ 10 bar N.C. Not available for N.O.	0 ÷ 10 bar N.C. 0 ÷ 7 bar N.O.	0 ÷ 7 bar DC only N.C. 0 ÷ 5 bar AC (N.O. and N.C.)
Working temperature	-5 ÷ +50 °C		
Fluid	Compressed air, filtered, continuous lubricated, unlubricated or dry lubricated		
Max. operating frequency	≤30 Hz		
Coil	Adjustable		
Voltages	DC: 24 V	DC: 12 - 24 V AC: 24 110 - 220 V	
Power consumption	DC: 1 W	DC: 2.5 W AC: 2.8 VA (inrush) - 2.5 VA (holding)	
Voltage tolerance	-5 ÷ +10%		
Protection class	IP 51 - IP 65 (versions: with embedded cables or standard + connector MEK192/N)		
Insulation class	F (155 °C)		
Duty cycle	Continuous rating (ED 100%)		
Energized	Solenoid with response time = 5 ms		
De-energized	Mechanical spring with response time = 10 ms		
Electric connectors	With faston: series MEK1 92/N - see chapter connectors on page 2.18 With 90° and in-line connectors: series CN - see chapter connectors on page 2.6		



2

MATERIALS

Core	Stainless steel
Body and manual override	PA and POM
Springs	Stainless steel
Seals	NBR and FKM rubber

ORDER KEY

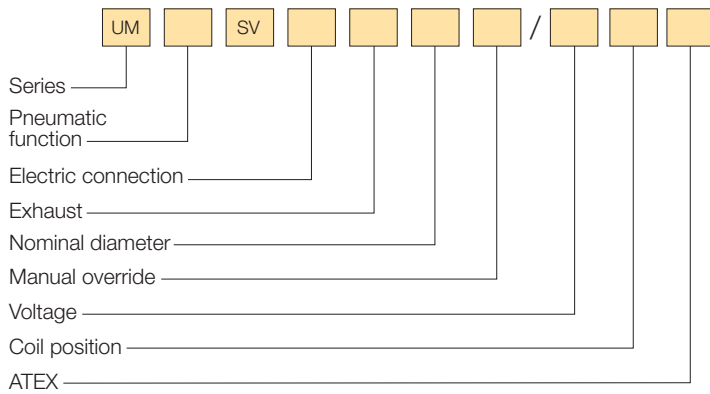

PNEUMATIC FUNCTION

2A	2/2 N.O.	2C	2/2 N.C.
A	3/2 N.O.	C	3/2 N.C.

ELECTRIC CONNECTION

With faston (standard)

OPTIONS

- 1 90° connector + bipolar LED and diode
- 2 Cable length 300 mm
- 3 Line connector + bipolar LED and diode
- 4 90° Connector
- 5 Line connector
- 7 Cable length 100 mm + Tyco® MODU II connector code 280358-0

EXHAUST

Channeled (standard)	L Free (only 3/2 N.C.)
----------------------	------------------------

NOMINAL DIAMETER

D	1.1 mm (standard) 0.8 mm exhaust 1.1 mm (only N.C.)	B	1.6 mm
---	--	---	--------

MANUAL OVERRIDE

F	Monostable push button (standard)	E	Without manual override and M3 insert
H	Without manual override	G	Without M3 insert
	Bistable screw driver slot		

VOLTAGE

01200	12V DC	02400	24V DC
02450-60	24V AC	11050-60	110V AC
22050-60	220V AC		

COIL POSITION

Standard	180 Rotated 180°
----------	------------------

ATEX*

/EX Consistent with the ATEX directive  II 3G c Ex nA IIC T5 Gc -5°C ≤ Ta ≤ 50°C
II 3D c Ex tc IIIC T100°C IP65 Dc

* Only with: cable 300 mm length and faston

series UM

Direct acting solenoid valves 15 mm

2

PNEUMATIC FUNCTIONS

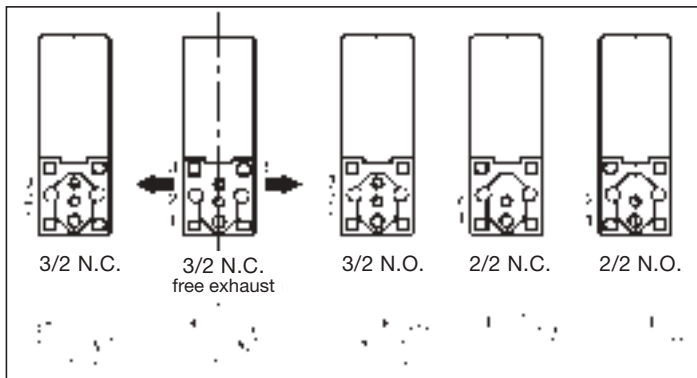

INTERFACE DIMENSIONS

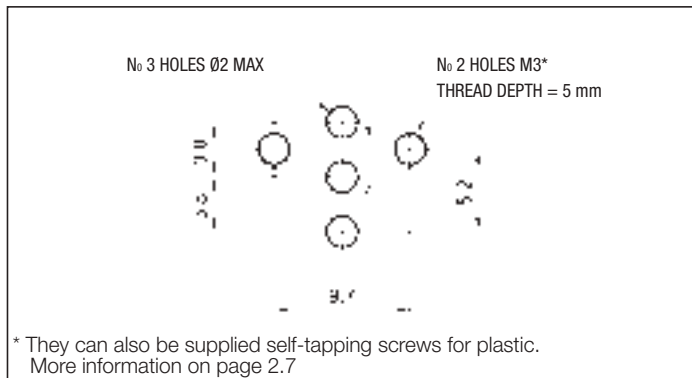

DIMENSIONS

WITH FASTON FOR MEK1 92/N CONNECTOR

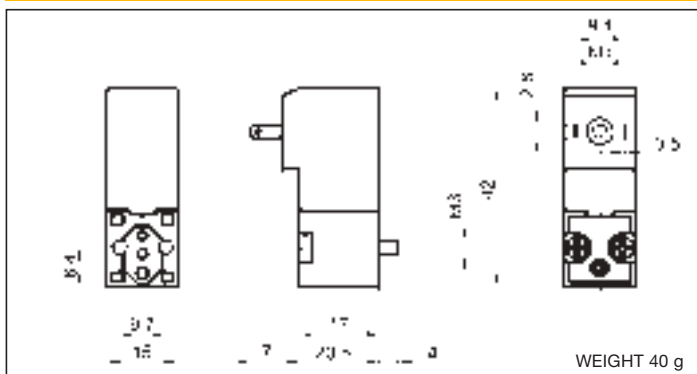

WITH CABLES

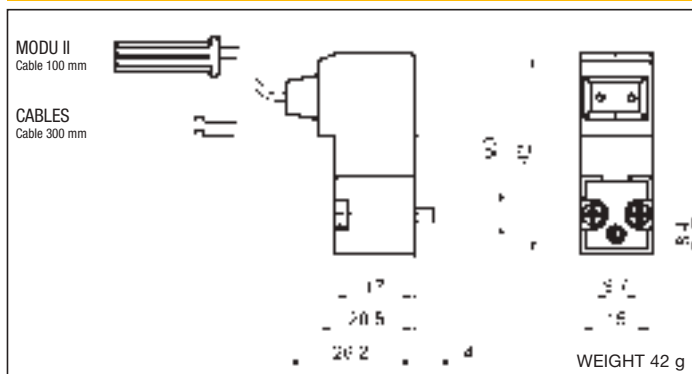

WITH 90° CONNECTOR

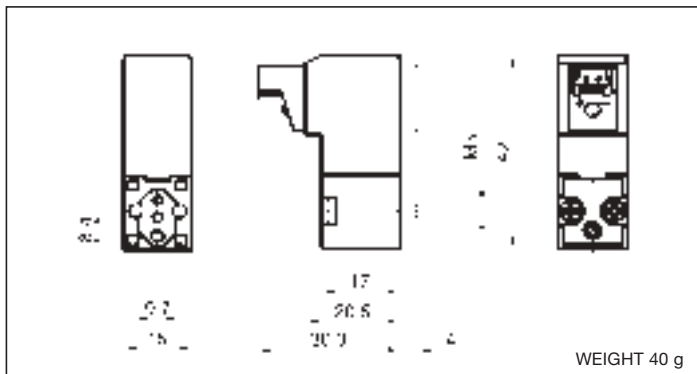

WITH IN-LINE CONNECTOR

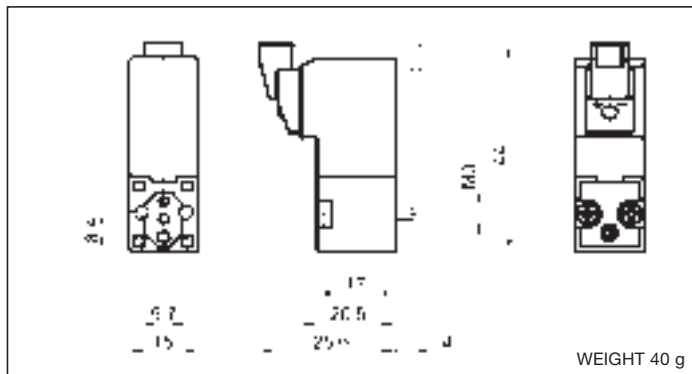

series CN

Connectors for solenoid valves 10 mm and 15 mm

CONNECTOR FOR SOLENOID VALVES WITH 90° CONNECTION OR IN-LINE CONNECTION

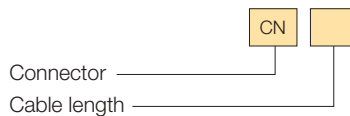
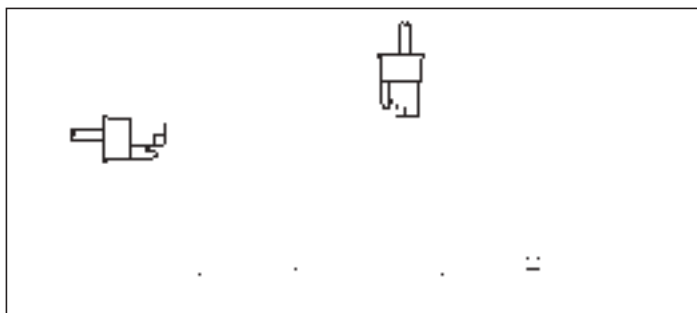

CABLE LENGTH

- 300 Cable length 300 mm
- 500 Cable length 500 mm
- 1000 Cable length 1000 mm

CLOSING PLATE - KIT/PC/UM

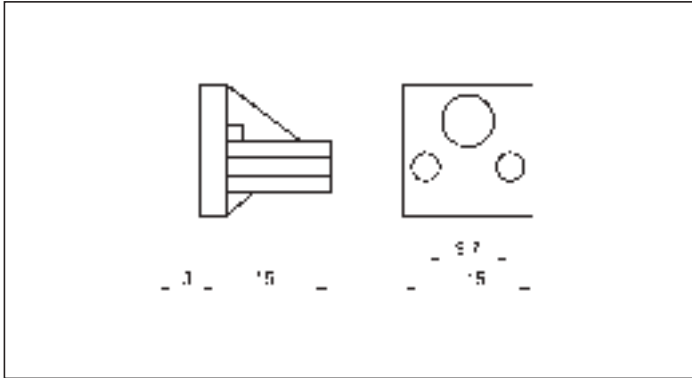

SINGLE BASE M5 - UMP5/1



MULTI -STATION BASE M5 - UMPM5

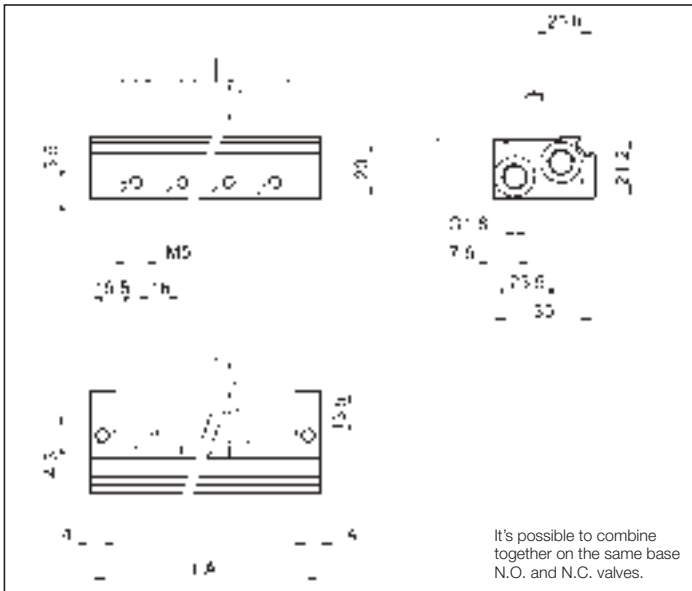

MULTI -STATION BASE WITH CARTRIDGE Ø4 mm UMP4-2

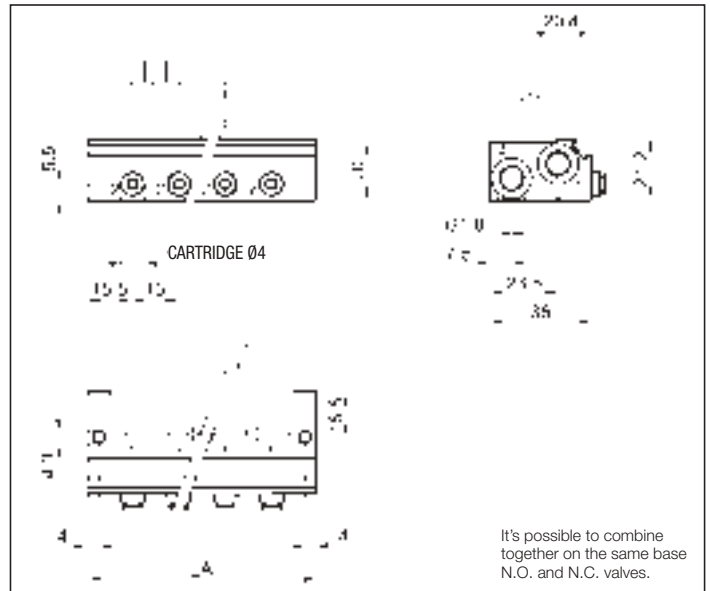

No. of stations	2	3	4	5	6	7	8	9	10
LA	47	63	79	95	111	127	143	159	175
Weight (g)	70	95	120	145	170	195	220	245	270
TYPE	UMPM5/2	UMPM5/3	UMPM5/4	UMPM5/5	UMPM5/6	UMPM5/7	UMPM5/8	UMPM5/9	UMPM5/10
Weight (g)	75	100	125	150	175	200	225	250	275
TYPE	UMP4-2/2	UMP4-2/3	UMP4-2/4	UMP4-2/5	UMP4-2/6	UMP4-2/7	UMP4-2/8	UMP4-2/9	UMP4-2/10

SELF-TAPPING SCREWS FOR PLASTIC

DESCRIPTION

It's possible to order the solenoid valves with self-tapping screws for plastic instead of the standard screws (metric). Drilling fixing dimensions are approximate and we always recommend to run some assembly test. To order valves with self-tapping screws, specify it when ordering by adding the suffix **"P"** to the order key of the **DM** and **UM** series. Only for DM series: to order valves with thread forming screws, specify it when ordering by adding the suffix **"T"** to the order key.

DRILLING SCHEME

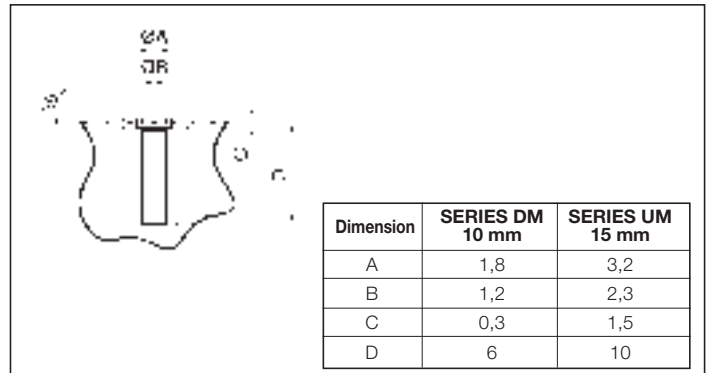

DESCRIPTION

The direct acting solenoid valves series "UL" are produced in the 3/2 N.O. (with feed from the exhaust "3") and 3/2 N.C. pneumatic functions. The function 2/2 is obtainable closing exhaust "3". Besides are available the versions with ports G 1/8, suitable for single use, and with interface for multi-station base mounting or for mounting on poppet and to ex CETOP RP 32 P (with fixed position) valve bodies. They can comply with ATEX directive, 3GD category, upon request.

2

TECHNICAL DATA

Operating pressure	0 ÷ 10 bar
Working temperature	0 ÷ +50 °C (-20 °C with dry air)
Fluid	Compressed air, filtered, continuous lubricated, unlubricated or dry lubricated
Nominal diameter	2 mm
Max. operating frequency	≤13 Hz
Coil	Integrated in the body
Voltages	DC: 24 V AC: 24 - 110 - 220 V
Apparent power	DC: 7 W AC: 17 VA (in rush) - 10 VA (holding)
Voltage tolerance	-15% +15%
Protection class	IP 65
Insulation class	F (155 °C)
Solenoid rating	ED 100%
Electric connector	ULR1B - see chapter connectors on page 2.18

MATERIALS

Core	IMRE
Body ported G 1/8	Zamak
Body with interface	Glass stiffened polyamide (zamak upon request)
Springs	Stainless steel
Seals	Viton®
Manual override	Acetal resin



FLOW CHART - UL

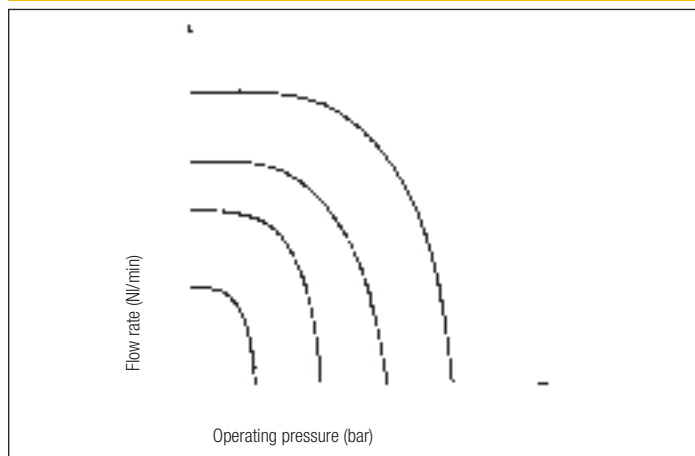

3 PORT G 1/8 ZAMAK - UL.../R

Symbol	Function	Controls		Response time at 6 bar (ms)		Flow rate P.A. 6 bar ΔP = 1 bar (NL/min)	Manual override	Weight (g)	TYPE*
		Pilot	Return	Pilot	Return				
	3/2 N.O.	Solenoid	Mechanical spring	15	20	80	-	240	ULARG/R
	3/2 N.C.	Solenoid	Mechanical spring	15	20	80	-	240	ULCRG/R
	3/2 N.O.	Solenoid	Mechanical spring	15	20	80	Manual bistable	240	ULARV/R
	3/2 N.C.	Solenoid	Mechanical spring	15	20	80	Manual bistable	240	ULCRV/R

* SPECIFY THE VOLTAGE IN THE ORDER

E.G.: **ULARG/R02450-60**

02400 = 24 V DC

02450-60 = 24 V AC

11050-60 = 110 V AC

22050-60 = 220 V AC

/EX Consistent with the ATEX directive II 3G c Ex nA IIC T4 Gc -5°C≤Ta≤50°C



II 3D c Ex tc IIIC T135°C IP65 Dc

E.G.: **ULCRV/R02400/EX**

3 PORT G 1/8 ZAMAK - UL...R./R

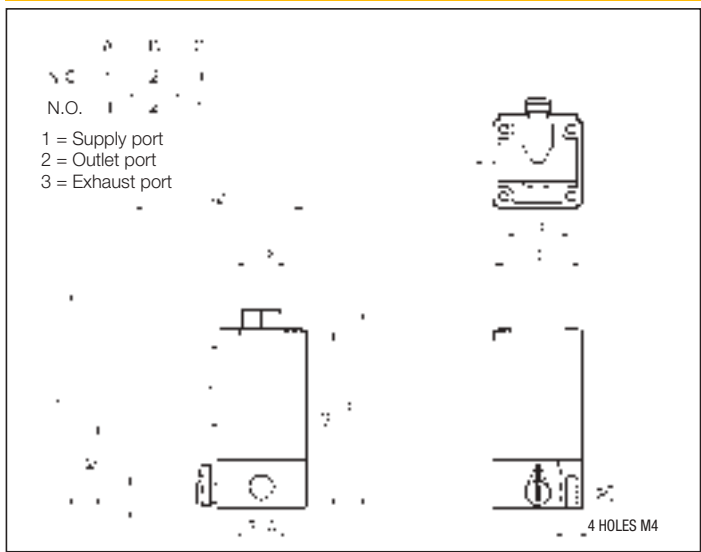

3 PORT WITH UNIVERSAL PLASTIC INTERFACE STRIP- UL.../U

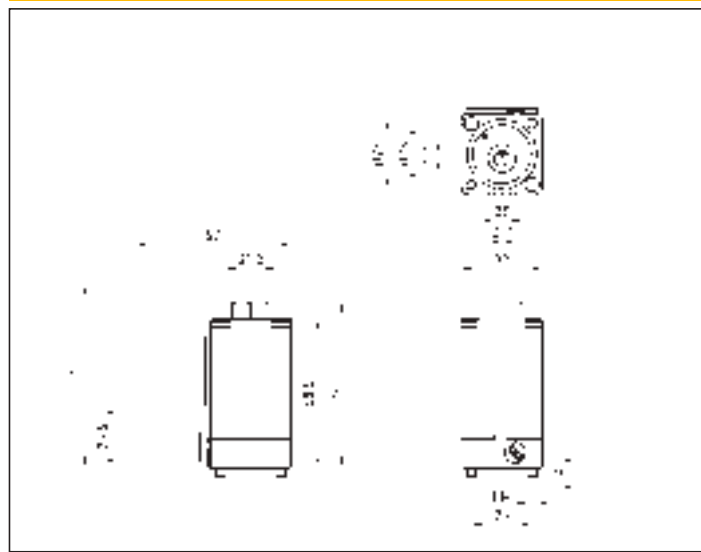

3 PORT WITH INTERFACE FOR MULTI-STATION BASES AND POPPET / EX CETOP VALVES (WITH FIXED POSITION)

Symbol	Function	Controls		Response time at 6 bar (ms)		Flow rate P.A. 6 bar ΔP = 1 bar (Nl/min)	Manual override	Weight (g)	TYPE*
		Pilot	Return	Energized	De-energized				
	3/2 N.O.	Solenoid	Mechanical spring	15	20	80	-	200	ULASG/R
	3/2 N.C.	Solenoid	Mechanical spring	15	20	80	-	200	ULCSG/R
	3/2 N.O.	Solenoid	Mechanical spring	15	20	80	Manual bistable	200	ULASV/R
	3/2 N.C.	Solenoid	Mechanical spring	15	20	80	Manual bistable	200	ULCSV/R

* SPECIFY THE VOLTAGE IN THE ORDER
 E.G.: **ULARG/R02450-60**
 02400 = 24 V DC 11050-60 = 110 V AC
 02450-60 = 24 V AC 22050-60 = 220 V AC
 /EX Consistent with the ATEX directive II 3G c Ex nA IIC T4 Gc -5°C ≤ Ta ≤ 50°C
 E.G.: **ULCSV/R02400/EX** II 3D c Ex tc IIIC T135°C IP65 Dc

P.S. 1: For body valve in zamak add the letter "A" to the type.
 E.G.: 3/2 N.C. with manual override, body in zamak **ULCSV/RA** + voltage.
 P.S. 2: For body valve in plastic and universal interface strip change the letter "R" of the type with the letter "U".
 E.G.: 3/2 N.C. with manual override, body in plastic **ULCSV/U** + voltage.

3 PORT WITH PLASTIC INTERFACE STRIP - UL...S./R

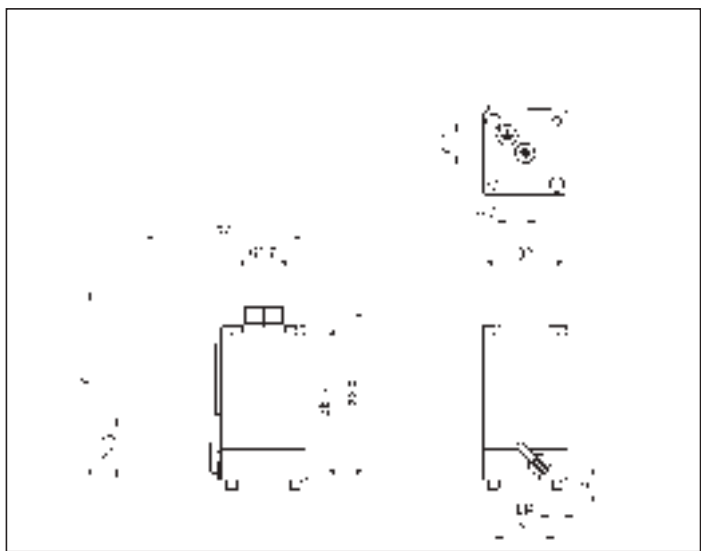

3 PORT WITH ZAMAK INTERFACE STRIP - UL.../RA

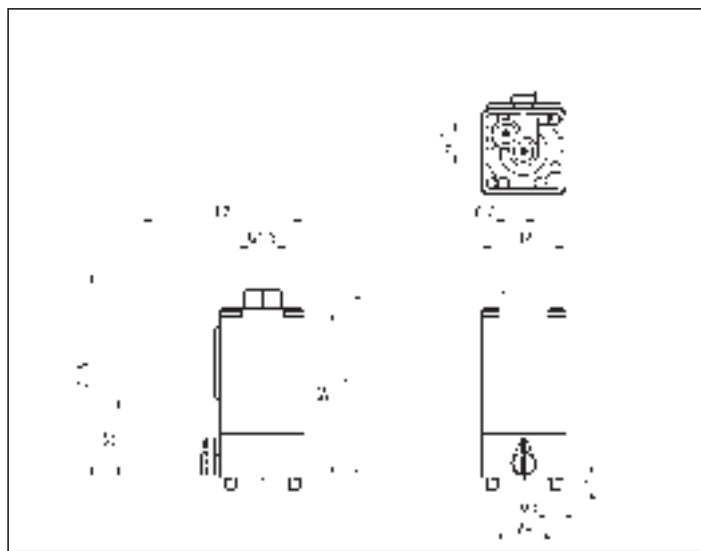

2

MULTI-STATION BOTTOM PORTED BASE G 1/8 - ULP8B

No of stations	2	3	5
LA	68	102	170
LB	59	93	161
LC	-	34	34
Weight (g)	85	130	220
TYPE	ULP8B/2	ULP8B/3	ULP8B/5

It is NOT possible to combine together N.O. & N.C. solenoid valves on the same manifold base.

P.S.: Base is supplied complete with plug, tubing and junction seals.

MULTI-STATION SIDE PORTED BASE G 1/8 - ULP8S

No of stations	2	3	5
LA	68	102	170
LB	59	93	161
Weight (g)	85	130	220
TYPE	ULP8S/2	ULP8S/3	ULP8S/5

It is NOT possible to combine together N.O. & N.C. solenoid valves on the same manifold base.

P.S.: Base is supplied complete with plug, tubing and junction seals.

SINGLE BASE G 1/8 - XVB

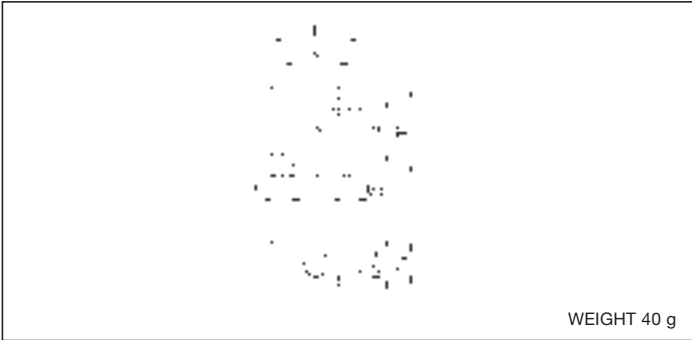

BLANKING PLATE - KIT/PC/UL



2

EXAMPLE OF BASES ASSEMBLY

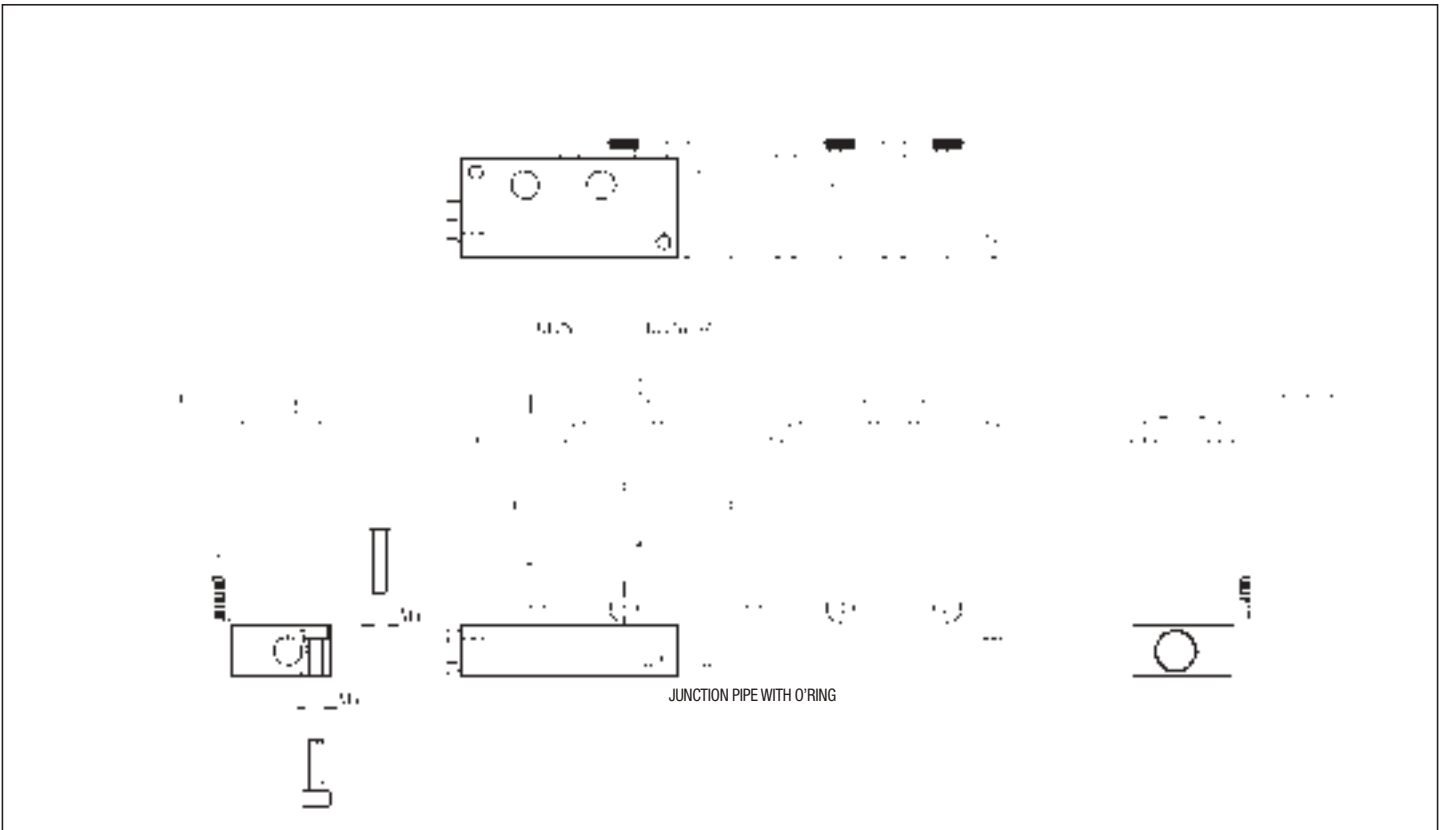

P.S.: The connection nipple is supplied as standard with the multi-station base

DESCRIPTION

The direct acting solenoid valves series "C/" are produced in the 3/2 N.O. and 3/2 N.C. pneumatic functions. Using the same mechanic, it is possible to obtain four standard versions: side 22 mm - body ported, side 22 mm - body with interface, side 30 mm - body with ex CNOMO interface and body with interface for mounting on poppet and ex CETOP (with fixed position and rotatable coil) valves. All the solenoid valves with interface can be mounted on single modular bases. The version side 30 mm with ex CNOMO interface, in the 3/2 N.C. pneumatic function, has two different manual overrides as standard: bistable screwdriver and monostable push button. They can comply with ATEX directive, 2GD category, upon request.

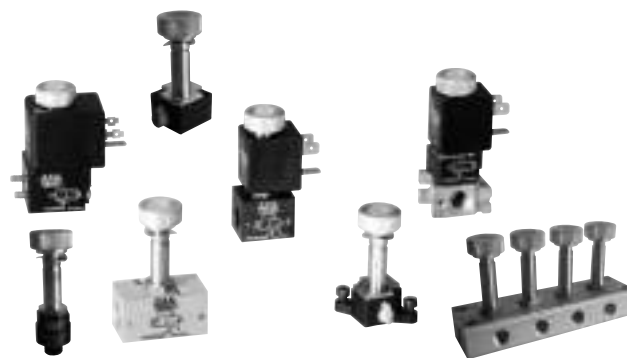

TECHNICAL DATA

Operating pressure	0 ÷ 10 bar N.C. 0 ÷ 8 bar N.O.
Working temperature	0 ÷ +50 °C (-20 °C with dry air)
Fluid	Compressed air, filtered, continuous lubricated, unlubricated or dry lubricated
Sleeve	Ø 9 mm
Nominal diameter	1,1 mm
Max. operating frequency	≤13 Hz
Coils	USB - see chapter Coils on page 2.17 USBG - see chapter Coils on page 2.17 USBG2 - see chapter Coils on page 2.17
Electric connectors	USR102/N9 - see chapter Connectors on page 2.18 ULR1B - see chapter Connectors on page 2.18

MATERIALS

Sleeve	Nickel-plated brass
Core	IMRE
Body ported G 1/8 - G 1/4	Aluminium
Body and manual override	Acetal resin
Locking ring nut	Plastic
Springs	Stainless steel
Seals	Viton®

FLOW CHART - C/

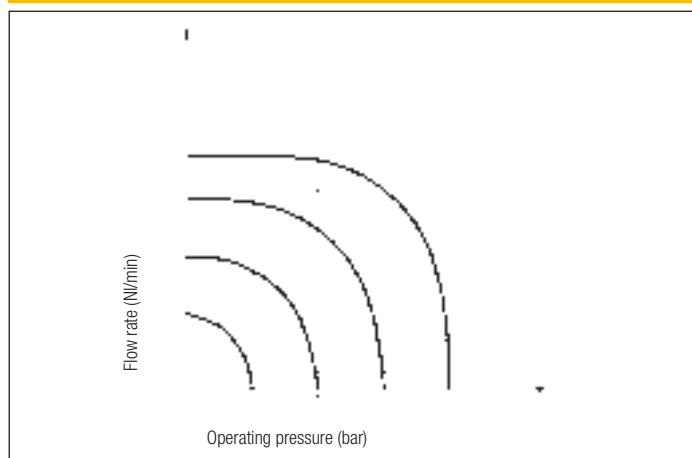

3 PORT G 1/8 - G 1/4 SIDE 22 mm

Symbol	Function	Controls		Response time at 6 bar (ms)		Flow rate at 6 bar ΔP = 1 bar (Nl/min)	Size	Manual override	Weight (g)	TYPE*
		Pilot	Return	Energized	De-energized					
	3/2 N.O.	Solenoid	Mechanical spring	10	20	48	G 1/8	-	46	C8/USASGG
	3/2 N.O.	Solenoid	Mechanical spring	10	20	48	G 1/4	-	46	C4/USASGG
	3/2 N.C.	Solenoid	Mechanical spring	10	20	36	G 1/8	-	65	C8/USCSGG
	3/2 N.C.	Solenoid	Mechanical spring	10	20	36	G 1/4	-	80	C4/USCSGG

* THE TYPES OF THE SOLENOID VALVES DO NOT INCLUDE COILS

/EX Consistent with the ATEX directive II 2GD c T5 T100°C -20°C ≤ Ta ≤ 50°C E.G.: C8/USASGG/EX

3 PORT G 1/8

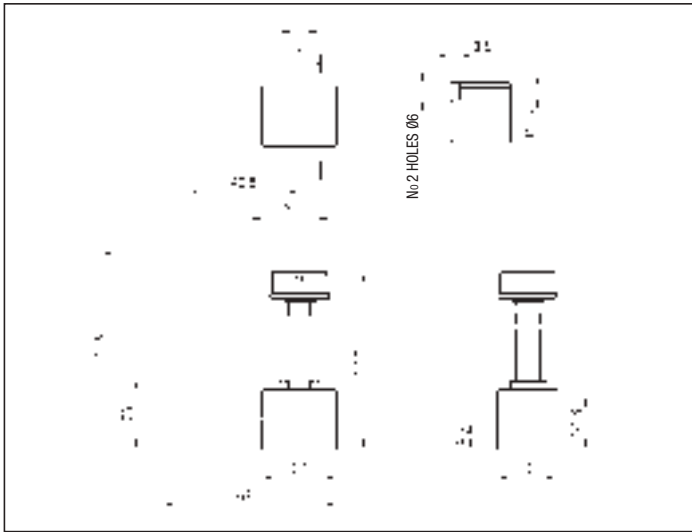

3 PORT G 1/4

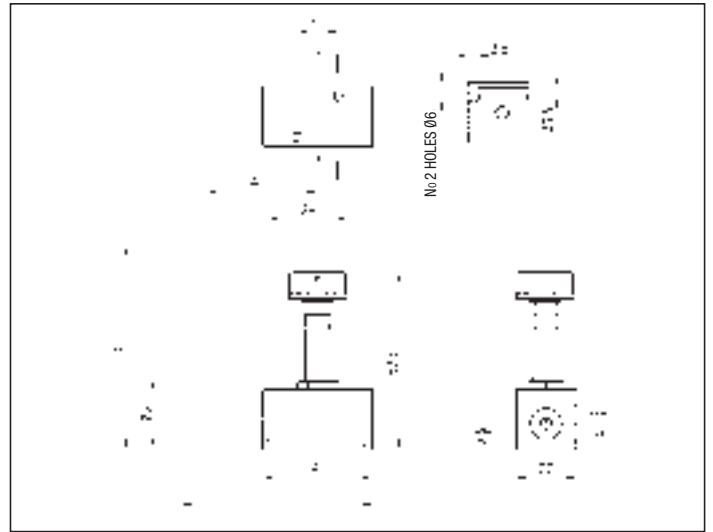

2

MANIFOLD BASE OF SOLENOID VALVES SIDE PORTED G 1/8 N.C. - C8/USCP AND N.O. - C8/USAP

No of stations	4	6	8
LA	115	165	215
LB	105	155	205
Weight (g)	172	258	344
TYPE N.C.	C8/USCP/4	C8/USCP/6	C8/USCP/8
TYPE N.O.	C8/USAP/4	C8/USAP/6	C8/USAP/8

It is possible to install N.O. solenoid valves with N.C. solenoid valves on the same modular base. Combination on request.

2

3 PORT WITH INTERFACE FOR MODULAR BASES AND SPOOL VALVES SIDE 22 mm

Symbol	Function	Controls		Response time at 6 bar (ms)		Flow rate at 6 bar ΔP = 1 bar (Nl/min)	Manual override	Weight (g)	TYPE*
		Pilot	Return	Energized	De-energized				
	3/2 N.O.	Solenoid	Mechanical spring	10	25	36	Manual monostable	45	C/USASVP
	3/2 N.O.	Solenoid	Mechanical spring	10	25	36	-	30	C/USASGP
	3/2 N.C.	Solenoid	Mechanical spring	10	25	36	Manual bistable	30	C/USCSVP
	3/2 N.C.	Solenoid	Mechanical spring	10	25	36	-	30	C/USCSGP

* THE TYPES OF THE SOLENOID VALVES DO NOT INCLUDE COILS /EX Consistent with the ATEX directive II 2GD c T5 T100°C -20°C≤Tas≤50°C ES.:C/USASVP/EX

C/USCSVP



C/USASVP - C/USASGP

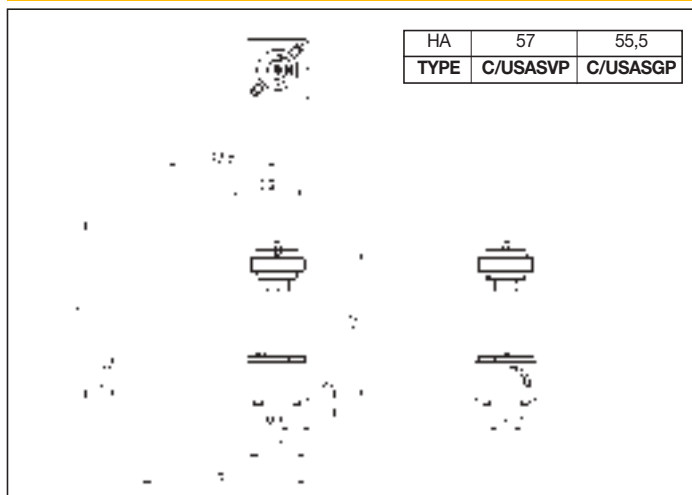

MODULAR BASE SIDE PORTED G 1/8 - ELPP8S

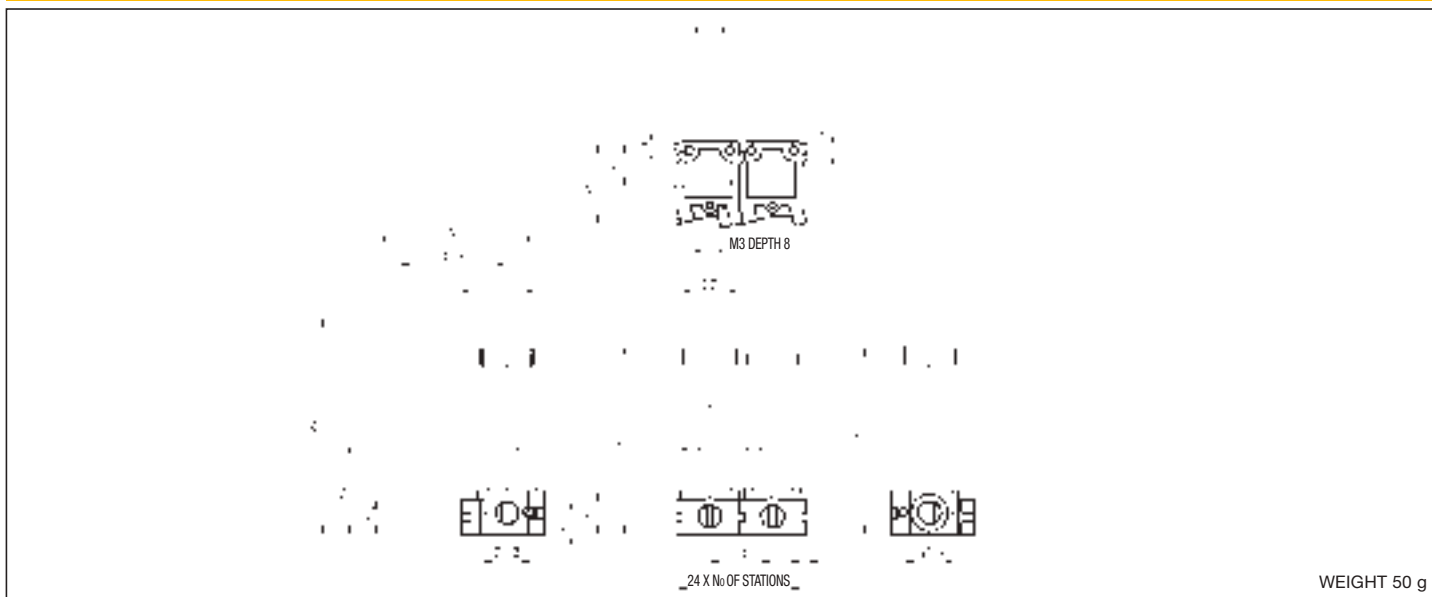

HOW TO ORDER A SOLENOID VALVE COMPLETE OF COIL AND BASE
Example: 3/2 N.C. solenoid valve base mounted (with manual override) + coil 24 V D.C. - ELPP8S/P/USB/02400

DESCRIPTION	TYPE
3/2 N.O. + base + coil (with manual override)	ELPP8S/PAV/USB/voltage
3/2 N.O. + base + coil (without manual override)	ELPP8S/PAG/USB/voltage
3/2 N.C. + base + coil (with manual override)	ELPP8S/P/USB/voltage

3 PORT WITH EX CNOMO INTERFACE FOR MODULAR BASES AND VALVES TO ISO 5599/1

Symbol	Function	Controls		Response time at 6 bar (ms)		Flow rate at 6 bar ΔP = 1 bar (Nl/min)	Manual override	Weight (g)	TYPE*
		Pilot	Return	Energized	De-energized				
	3/2 N.O.	Solenoid	Mechanical spring	13	23	36	Manual monostable	60	C/UEASVB
	3/2 N.O.	Solenoid	Mechanical spring	13	23	36	-	45	C/UEASGB
	3/2 N.C.	Solenoid	Mechanical spring	10	25	36	Bistable screw driver slot	45	C/UECSVB
	3/2 N.C.	Solenoid	Mechanical spring	10	25	36	Monostable push button	45	C/UECSPB

* THE TYPES OF THE SOLENOID VALVES DO NOT INCLUDE COILS /EX Consistent with the ATEX directive II 2GD c T5 T100°C -20°C≤Ta≤50°C ES.:C/UEASVB/EX

C/UECSVB - C/UECSPB

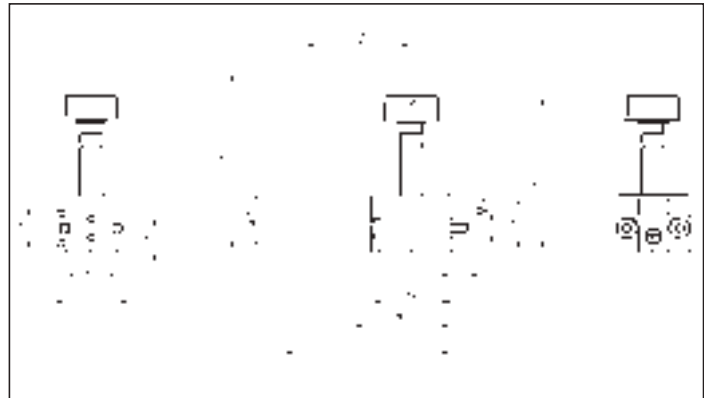

C/UEASVB - C/UEASGB

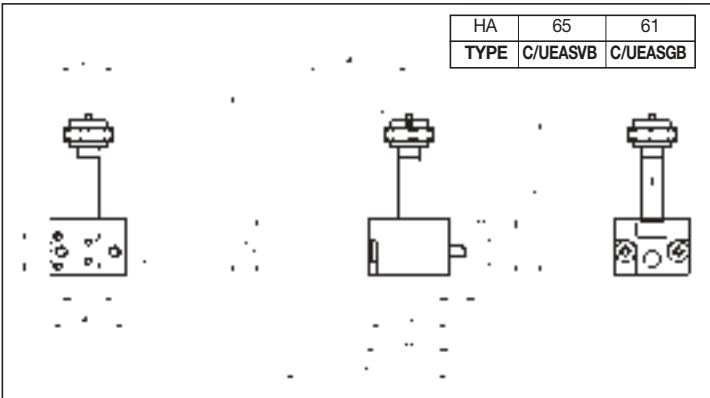

EX CNOMO MODULAR BASE SIDE PORTED G 1/8 - ELPG8S

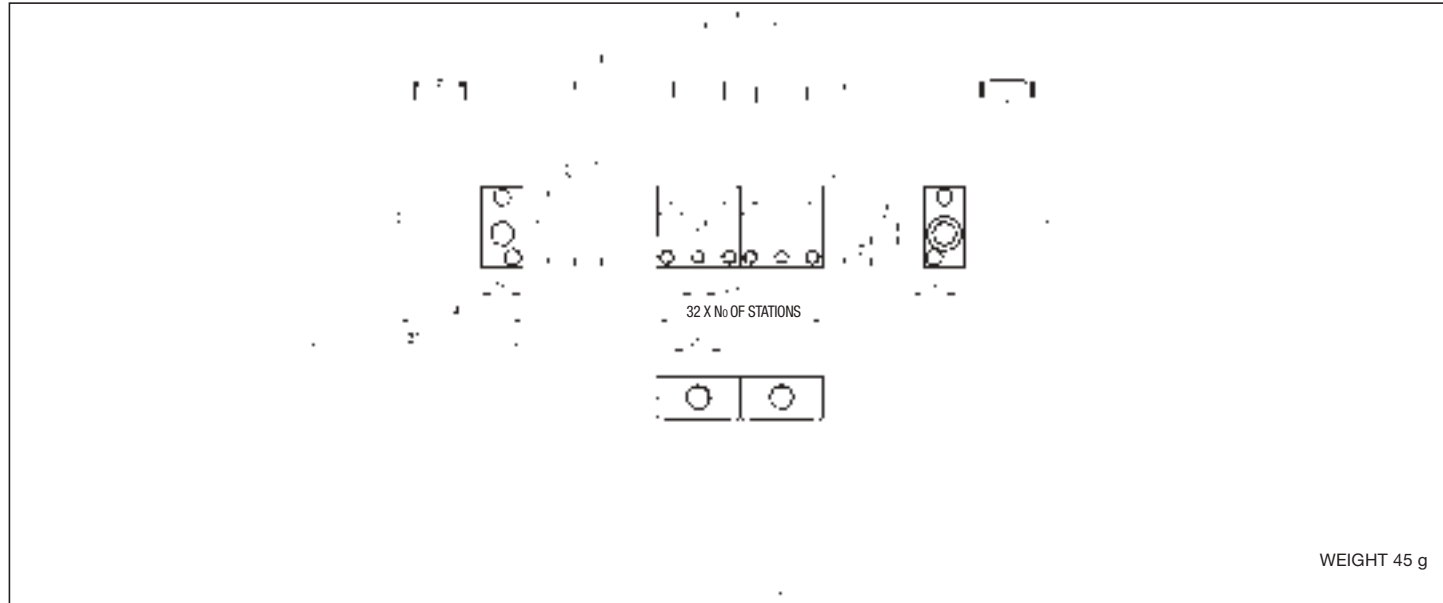

P.S.: Base includes the coupling pin with grains and seals.

HOW TO ORDER A SOLENOID VALVE COMPLETE OF COIL AND BASE
 Example: 3/2 N.O. solenoid valve base mounted (with manual override)
 + coil 24 V DC **ELPG8S/BAV/USBG/02400**

DESCRIPTION	TYPE
3/2 N.O. + base + coil (with manual override)	ELPG8S/BAV/USBG/voltage
3/2 N.O. + base + coil (without manual override)	ELPG8S/BAG/USBG/voltage
3/2 N.C. + base + coil (with manual override)	ELPG8S/B/USBG/voltage
3/2 N.C. base + coil (with push button manual override)	ELPG8S/BP/USBG/voltage

3 PORT WITH INTERFACE FOR POPPET AND EX CETOP (WITH FIXED POSITION AND ROTATABLE COIL) VALVES

Symbol	Function	Controls		Response time at 6 bar (ms)		Flow rate at 6 bar $\Delta P = 1 \text{ bar (Nl/min)}$	Manual override	Weight (g)	TYPE*
		Pilot	Return	Energized	De-energized				
	3/2 N.C.	Solenoid	Mechanical spring	10	25	36	Manual bistable	30	C/USCSVG

2

* THE TYPES OF THE SOLENOID VALVES DO NOT INCLUDE COILS /EX Consistent with the ATEX directive II 2GD c T5 T100°C -20°C ≤ Ta ≤ 50°C ES.:C/USCSVG/EX

C/USCSVG

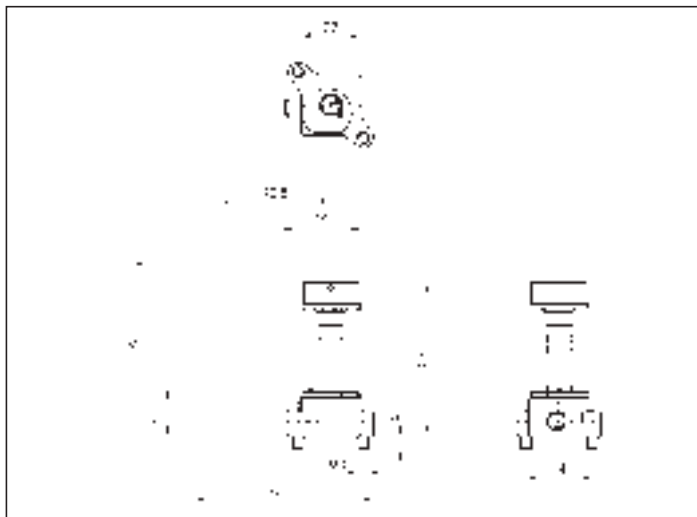

3 PORT BODY PORTED G 1/8 FOR DIRECT MOUNTING

This solenoid valve has been specifically designed to pilot single acting small cylinders and pneumatic valves. The input connection is M5 while the output has a male thread G1/8 that allows the direct assembling of the solenoid valve on the component.

Symbol	Function	Controls		Response time at 6 bar (ms)		Flow rate at 6 bar $\Delta P = 1 \text{ bar (Nl/min)}$	Manual override	Weight (g)	TYPE*
		Pilot	Return	Energized	De-energized				
	3/2 N.O.	Solenoid	Mechanical spring	10	20	36	-	46	A/ELP8M
	3/2 N.C.	Solenoid	Mechanical spring	10	20	36	-	46	C/ELP8M

* THE TYPES OF THE SOLENOID VALVES DO NOT INCLUDE COILS /EX Consistent with the ATEX directive II 2GD c T5 T100°C -20°C ≤ Ta ≤ 50°C ES.:C/ELP8M/EX

C/ELP8M

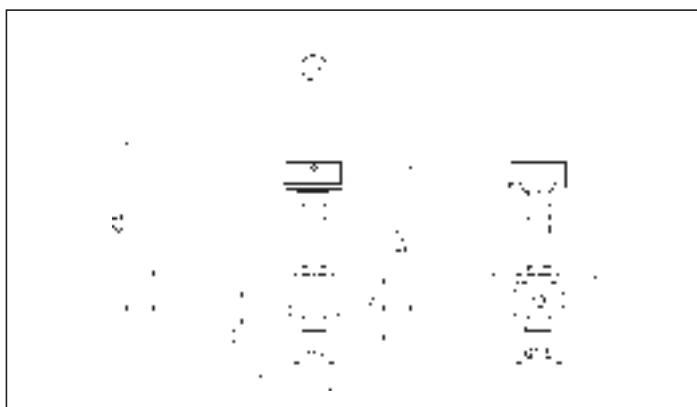

Coils for solenoid valves with sleeve Ø 9 mm

series USB/USBG

TECHNICAL DATA USB - USBG

Voltages	DC: 24 V AC: 24 - 110 - 220 V
Working temperature	-30 ÷ +40 °C basic version -30 ÷ +70 °C low absorption version
Versions	Basic version DC: 5 W AC: 11 VA (inrush) - 8 VA (holding) Low absorption version DC: 3 W AC: 5,6 VA (inrush) - 2,5 VA (holding)
Standard frequencies	AC 50 - 60 Hz
Voltage tolerance	-10% +10%
Coil insulation class	H (180 °C)
Solenoid rating	ED 100%
Electrical connection	Fit for connector to DIN 46244 standard See chapter Connectors on page 2.18
Protection class with connector	IP 65 EN 60529

MATERIALS USB - USBG

Body	Glass stiffened polyamide
Coil winding	Copper wire

USBG



USB

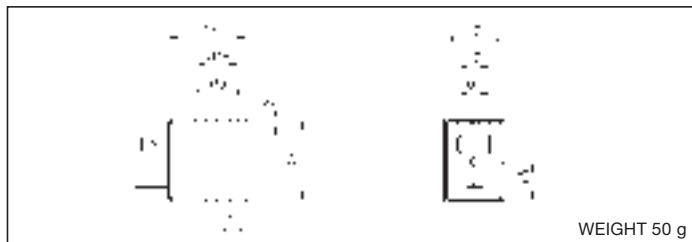

DESCRIPTION	TYPE*
Coil 22 mm 24 V DC	USB/02400
Coil 22 mm 24 V AC	USB/02450-60
Coil 22 mm 110 V AC	USB/11050-60
Coil 22 mm 220 V AC	USB/22050-60
OTHER VOLTAGES	USB/...

***/EX** Consistent with the ATEX directive II 3G Ex nA IIC T4 Gc -30°C≤Ta≤40°C
II 3D Ex tc IIIC T135°C IP65 Dc

E.G.: **USB/02400/EX**

P.S.: ADD THE SUFFIX "-BA" JUST AFTER THE USB TYPE, TO ORDER THE LOW ABSORPTION VERSION COILS. E.G.: **USB-BA/02400**

DESCRIPTION	TYPE*
Coil 30 mm 24 V DC	USBG/02400
Coil 30 mm 24 V AC	USBG/02450-60
Coil 30 mm 110 V AC	USBG/11050-60
Coil 30 mm 220 V AC	USBG/22050-60
OTHER VOLTAGES	USBG/...

***/EX** Consistent with the ATEX directive II 3G Ex nA IIC T4 Gc -30°C≤Ta≤40°C
II 3D Ex tc IIIC T135°C IP65 Dc

E.G.: **USBG/02400/EX**

P.S.: ADD THE SUFFIX "-BA" JUST AFTER THE USBG TYPE, TO ORDER THE LOW ABSORPTION VERSION COILS. E.G.: **USBG-BA/02400**

Coils for solenoid valves side 30 mm with sleeve Ø 9 mm conform to ATEX 2GD directive

series USBG2/EX

TECHNICAL DATA

Voltages	DC: 24 V AC: 24 V
Working temperature	-50 ÷ +50 °C
Versions	DC: 3 W AC: 4,8 VA (inrush) - 3,2 VA (holding)
Standard frequencies	AC 50 - 60 Hz
Voltage tolerance	-10% +10%
Coil insulation class	H (180 °C)
Solenoid rating	ED 100%
Connectors	3 m long emerging cable
Protection class	IP 66

MATERIALS

Body	Glass stiffened polyamide
Coil winding	Copper wire

USBG 2 - ATEX 2GD

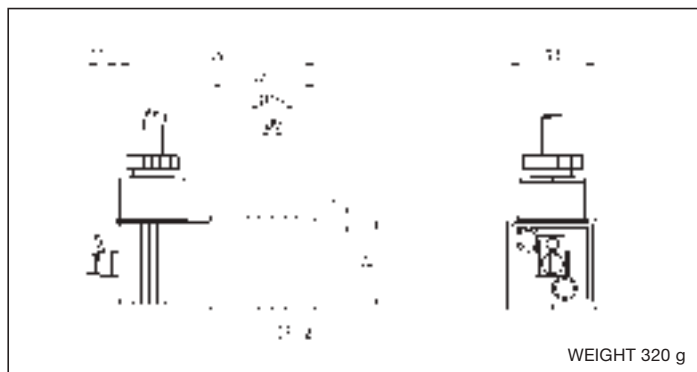

DESCRIPTION	TYPE*
Coil 30 mm 24 V DC	USBG2/02400/EX
Coil 30 mm 24 V AC	USBG2/02450-60/EX

***/EX** Consistent with the ATEX directive II 2G Ex mb IIC T5 Gb -50°C≤Ta≤40°C
II 2D Ex tb IIIC T95°C IP65 Db

E.G.: **USBG2/02400/EX**

P.S.: For different voltages, please contact our commercial office

series MEK192/N

Connectors DIN 43650-C
for solenoid valves
side 15 mm series UM

TECHNICAL DATA

Voltages	DC: MAX 300 V AC: MAX 250 V
Working temperature	-40 ÷ +90 °C
Versions	Basic With indicator light (LED) With indicator light (LED) and varistat (VDR) as electrical protection
Number of pins	2 + earthed
Nominal current	6 A
Maximum current	10 A
Contacts resistance	≤ 4 mOhm
Protection class	IP 65 EN 60529
Connector insulation class	IEC 664 / VDE 0110-1/89

***EX** Consistent with the ATEX directive  II 2G IIC T6 Gb
II 2D Ex tb IIIC T85°C Db IP65/IP67

E.G.: **MEK192/N/EX**

MEK192/N

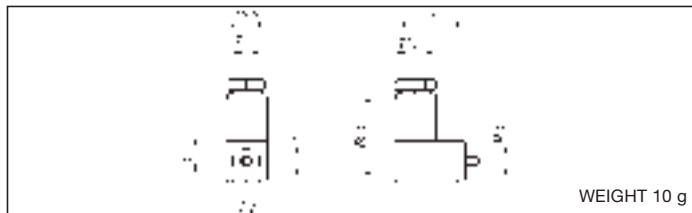

WEIGHT 10 g

DESCRIPTION	TYPE
Basic connector	MEK192/N*
Connector with led + VDR as protection 24 V DC/AC	MEK192/NVD 24 V CC/CA
Connector with led + VDR as protection 110 V DC/AC	MEK192/NVD 110 V CC/CA
Connector with led + VDR as protection 220 V DC/AC	MEK192/NVD 220 V CC/CA
Connector with led 24 V DC/AC	MEK192/NLED 24 V CC/CA
Connector with led 110/220 V DC/AC	MEK192/NLED 110/220 V CC/CA

series USR102/N9

Connectors DIN 43650-B
for coils side 22 mm series
USB and series WE (3A)

TECHNICAL DATA

Voltages	DC: MAX 300 V AC: MAX 250 V
Working temperature	-40 ÷ +90 °C
Versions	Basic With indicator light (LED) With indicator light (LED) and varistat (VDR) as electrical protection
Number of pins	2 + earthed
Nominal current	10 A
Maximum current	16 A
Contacts resistance	≤ 4 mOhm
Protection class	IP 65 EN 60529
Connector insulation class	IEC 664 / VDE 0110-1/89

***EX** Consistent with the ATEX directive  II 2G IIC T6 Gb
II 2D Ex tb IIIC T85°C Db IP65/IP67

E.G.: **USR102/N9/EX**

USR102/N9

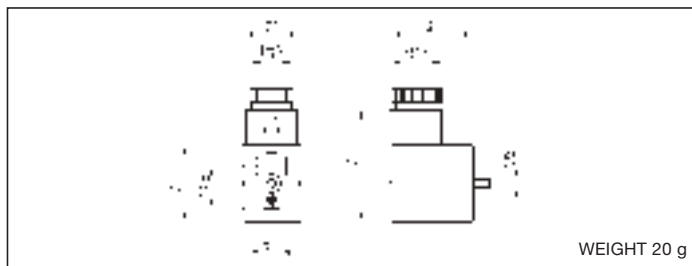

WEIGHT 20 g

DESCRIPTION	TYPE
Basic connector	USR102/N9*
Connector with led + VDR as protection 24 V DC/AC	USR102/N9VD 24 V CC/CA
Connector with led + VDR as protection 110 V DC/AC	USR102/N9VD 110 V CC/CA
Connector with led + VDR as protection 220 V DC/AC	USR102/N9VD 220 V CC/CA
Connector with led 24 V DC/AC	USR102/N9LED 24 V CC/CA
Connector with led 110/220 V DC/AC	USR102/N9LED 110/220 V CC/CA

series ULR1B

Connectors DIN 43650-A for
solenoid valves side 30 mm series UL and
coils series USBG and series WE (2A, 5A)

TECHNICAL DATA

Voltages	DC: MAX 300 V AC: MAX 250 V
Working temperature	-40 ÷ +90 °C
Versions	Basic With indicator light (LED) With indicator light (LED) and varistat (VDR) as electrical protection
Number of pins	2 + earthed
Nominal current	10 A
Maximum current	16 A
Contacts resistance	≤ 4 mOhm
Protection class	IP 65 EN 60529
Connector insulation class	IEC 664 / VDE 0110-1/89

***EX** Consistent with the ATEX directive  II 2G IIC T6 Gb
II 2D Ex tb IIIC T85°C Db IP65/IP67

E.G.: **ULR1B/EX**

ULR1B

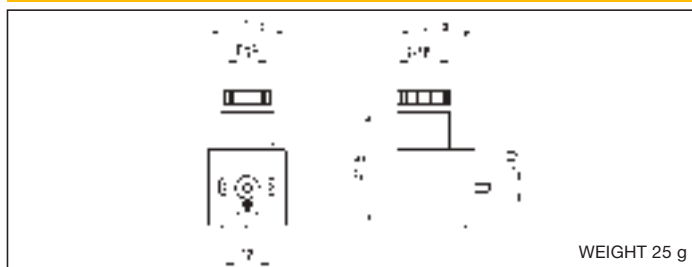

WEIGHT 25 g

DESCRIPTION	TYPE
Basic connector	ULR1B*
Connector with led + VDR as protection 24 V DC/AC	ULR1B/VD 24 V CC/CA
Connector with led + VDR as protection 110 V DC/AC	ULR1B/VD 110 V CC/CA
Connector with led + VDR as protection 220 V DC/AC	ULR1B/VD 220 V CC/CA
Connector with led 24 V DC/AC	ULR1B/LED 24 V CC/CA
Connector with led 110/220 V DC/AC	ULR1B/LED 110/220 V CC/CA

DESCRIPTION

Valves series "SK" are produced the size G1/8 in the following pneumatic functions: 3/2, 5/2, 5/3 and "3/2+3/2". The electrical version can mount two kinds of piloting solenoid valves: the 15 mm one (type "SK815") or the 22 mm integrated one (type "SK822"). Valves series "SK" can be used single or in manifold mounting, regardless the pneumatic functions: 5/3, 5/2 and 3/2, the last one using the adapter type "KIT/A/SK8". The version "3/2+3/2" includes No. 2-3/2 valves in a single body, so with a very compact overall dimensions compared to the No. 2 valves it's replacing in terms of pneumatic function, as well as compared to the pressure or open center versions. Upon request, they can be supplied in compliance with ATEX directive, category 3GD for electrical version with 15mm piloting solenoid valve and category 2GD for other versions.



TECHNICAL DATA

Operating pressure	Monostable: 2,5 ÷ 8 bar Bistable: 1,5 ÷ 8 bar
Working temperature	0 ÷ +60 °C (-10 °C with dry air)
Fluid	Compressed air, filtered, continuous lubricated, unlubricated or dry lubricated
Port size	G 1/8
Pneumatic piloting port size	M5
Nominal diameter	G 1/8 = 6 mm
Piloting solenoid valve	15 mm: UMCSV - see on page 2.5 22 mm integrated in the bottom
Coils	USB - see chapter Coils on page 2.17 USBG - see chapter Coils on page 2.17* USBG2 - see chapter Coils on page 2.17*
Electric connectors	MEK192/N with UMCSV USR102/N9 with C/USCSVP ULR1B with C/USCSVP* see chapter Connectors on page 2.18

* Just for the valve single used (coil and connector protrude from the dimension of the valves).

MATERIALS

Bottoms	Technopolymer
Body	Cast painted aluminium alloy
Distance ring	Acetal resin-brass
Springs	Stainless steel
Seals	NBR rubber
Spools	Nickel-plated steel
Piston	Anodized aluminium alloy

SPARE PARTS

SEALS KIT	
3/2 - G 1/8	SK/SG/8
5/2 - G 1/8	SKCA/SG/8
5/3 - G 1/8	SKCA/SG/8 - 5/3
3/2 + 3/2 - G 1/8	SK/SG/8 - 2 x 3/2

FLOW CHART SK G 1/8

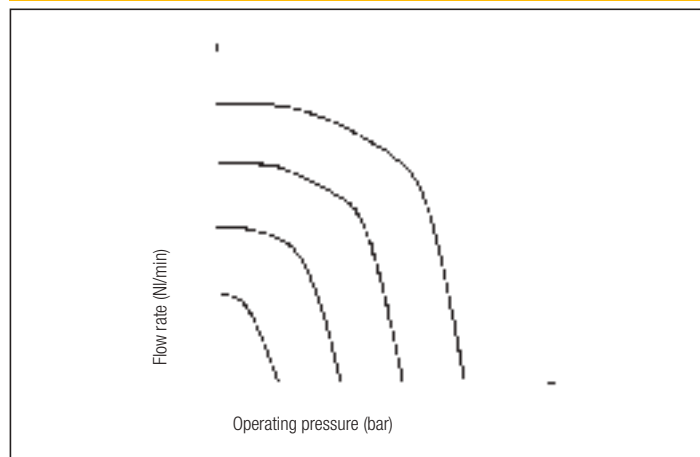

PILOTING CHART SK G 1/8

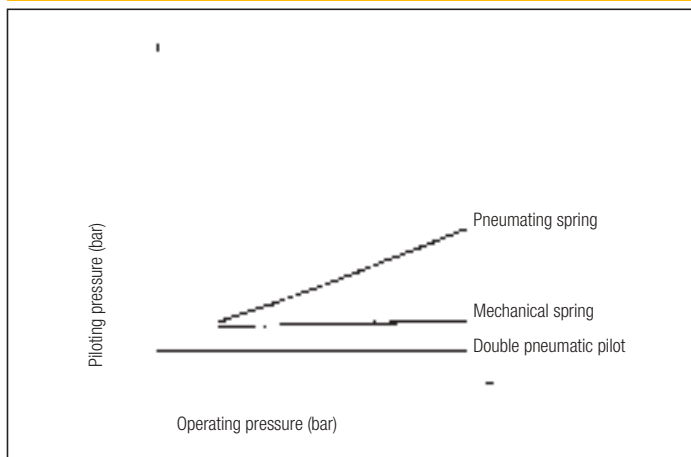

2

PILOT ACTUATED VALVE G 1/8 - 3 and 5 PORT

Symbol	Function	Controls		Response time at 6 bar (ms)		Flow rate at 6 bar $\Delta P = 1 \text{ bar (Nl/min)}$	Weight (g)	TYPE*
		Pilot	Return	Energized	De-energized			
	3/2 N.O. monostable	Pneumatic	Pneumomechanical spring	11	35	650	80	SKA8 KR/ZQ
		Pneumatic	Pneumatic spring	11	35	650	80	SKA8 KR/TQ
	3/2 N.C. monostable	Pneumatic	Pneumomechanical spring	11	35	650	80	SKC8 KR/ZQ
		Pneumatic	Pneumatic spring	11	35	650	80	SKC8 KR/TQ
	3/2 bistable	Pneumatic	Pneumatic	12	12	650	80	SK8 KR/KR
		Big pneumatic	Small pneumatic	12	14	650	80	SK8 KR/TR
	5/2 monostable	Pneumatic	Pneumomechanical spring	13	38	750	100	SKCA8 KR/ZQ
		Pneumatic	Pneumatic spring	13	38	750	100	SKCA8 KR/TQ
	5/2 bistable	Pneumatic	Pneumatic	11	11	750	100	SKCA8 KR/KR
		Big pneumatic	Small pneumatic	11	15	750	100	SKCA8 KR/TR
	5/3 closed centre	Pneumatic	Pneumatic spring	15	17	600	105	SKCA8 SR/SR
	3/2 N.O. + 3/2 N.O. monostable	Pneumatic	Pneumatic spring	15	17	600	105	SKA+A8 KR/ZR
	3/2 N.O. + 3/2 N.C. monostable	Pneumatic	Pneumatic spring	15	17	600	105	SKA+C8 KR/ZR
	3/2 N.C. + 3/2 N.O. monostable	Pneumatic	Pneumatic spring	15	17	600	105	SKC+A8 KR/ZR
	3/2 N.C. + 3/2 N.C. monostable	Pneumatic	Pneumatic spring	15	17	600	105	SKC+C8 KR/ZR

*/EX Consistent with the ATEX directive II 2GD c T5 T100°C -10°C ≤ T_a ≤ 60°C E.G.: SKA8 KR/ZQ/EX

3 PORT MONOSTABLE AND BISTABLE

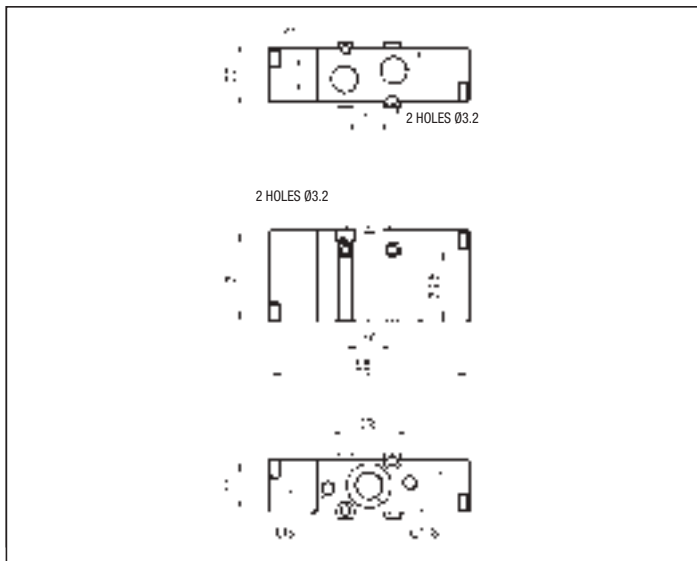

3+3 AND 5 PORT MONOSTABLE AND BISTABLE

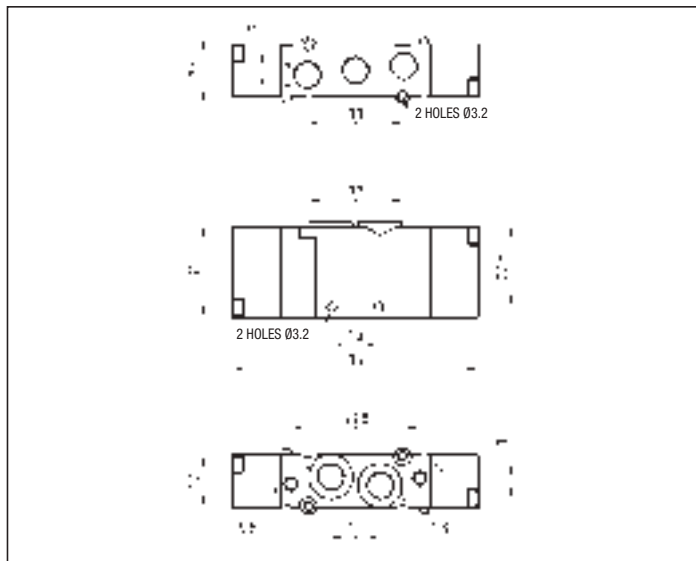

2

2

SOLENOID ACTUATED VALVES WITH 15 mm COIL G 1/8 - 3 PORT

Symbol	Function	Controls		Response time at 6 bar (ms)		Flow rate at 6 bar $\Delta P = 1$ bar (l/min)	Weight (g)	TYPE*
		Pilot	Return	Energized	De-energized			
	3/2 N.O. monostable	Solenoid	Pneumomechanical spring	11	35	650	116	SKA815 KUC/ZQ
		Solenoid	Pneumatic spring	11	35	650	116	SKA815 KUC/TQ
		Solenoid pilot assisted	Pneumomechanical spring	11	35	650	116	SKA815 KUR/ZQ
	3/2 N.C. monostable	Solenoid	Pneumomechanical spring	11	35	650	116	SKC815 KUC/ZQ
		Solenoid	Pneumatic spring	11	35	650	116	SKC815 KUC/TQ
		Solenoid pilot assisted	Pneumomechanical spring	11	35	650	116	SKC815 KUR/ZQ
	3/2 bistable	Solenoid	Solenoid	12	12	650	150	SK815 KUC/KUC
		Solenoid pilot assisted	Solenoid pilot assisted	11	11	650	150	SK815 KUR/KUR

* SPECIFY THE VOLTAGE IN THE ORDER - E.G.: **SKA815 KUC/ZQ 02450-60**

02400 = 24 V DC
02450-60 = 24 V AC

11050-60 = 110 V AC
22050-60 = 220 V AC

/EX Consistent with the ATEX directive II 3G c Ex nA IIC T5 Gc -5°C ≤ Ta ≤ 50°C
II 3D c Ex tc IIIC T100°C IP65 Dc

E.G.: **SKA815 KUC/ZQ 02450-60/EX**

3 PORT MONOSTABLE

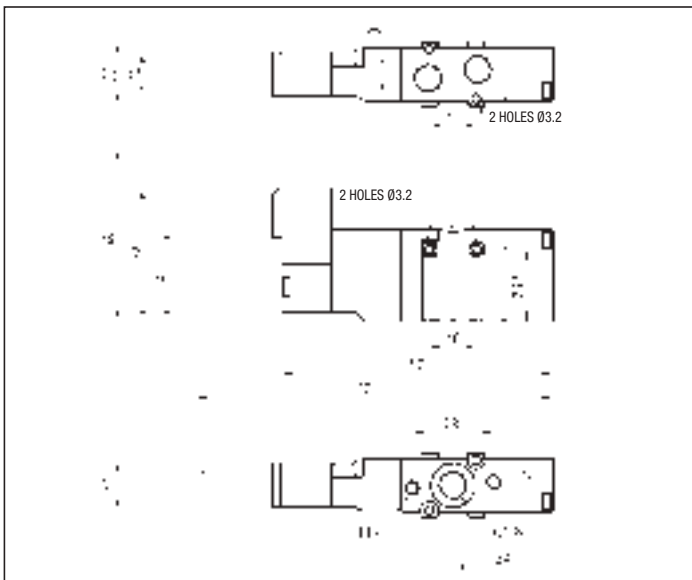

3 PORT BISTABLE

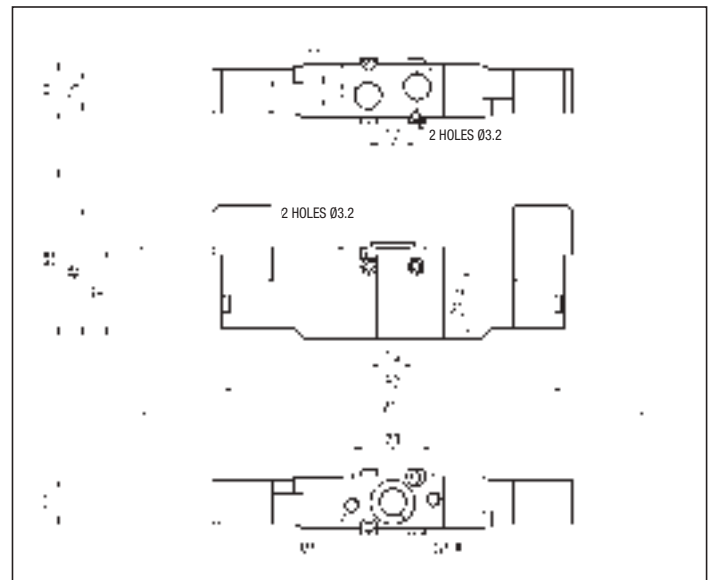

SOLENOID ACTUATED VALVES WITH Ø 9 mm SLEEVE G 1/8 - 3 PORT

Symbol	Function	Controls		Response time at 6 bar (ms)		Flow rate at 6 bar $\Delta P = 1$ bar (l/min)	Weight (g)	TYPE*
		Pilot	Return	Energized	De-energized			
	3/2 N.O. monostable	Solenoid	Pneumomechanical spring	11	35	650	110	SKA822 KUC/ZQ
		Solenoid	Pneumatic spring	11	35	650	110	SKA822 KUC/TQ
		Solenoid pilot assisted	Pneumomechanical spring	11	35	650	110	SKA822 KUR/ZQ
	3/2 N.C. monostable	Solenoid	Pneumomechanical spring	11	35	650	110	SKC822 KUC/ZQ
		Solenoid	Pneumatic spring	11	35	650	110	SKC822 KUC/TQ
		Solenoid pilot assisted	Pneumomechanical spring	11	35	650	110	SKC822 KUR/ZQ
	3/2 bistable	Solenoid	Solenoid	12	12	650	140	SK822 KUC/KUC
		Solenoid pilot assisted	Solenoid pilot assisted	12	12	650	140	SK822 KUR/KUR

*THE TYPES OF THE SOLENOID VALVE DO NOT INCLUDE COILS

/EX Consistent with the ATEX directive II 2GD c T5 T100°C -10°C ≤ Ta ≤ 60°C E.G.: **SKA822 KUC/ZQ**

3 PORT MONOSTABLE

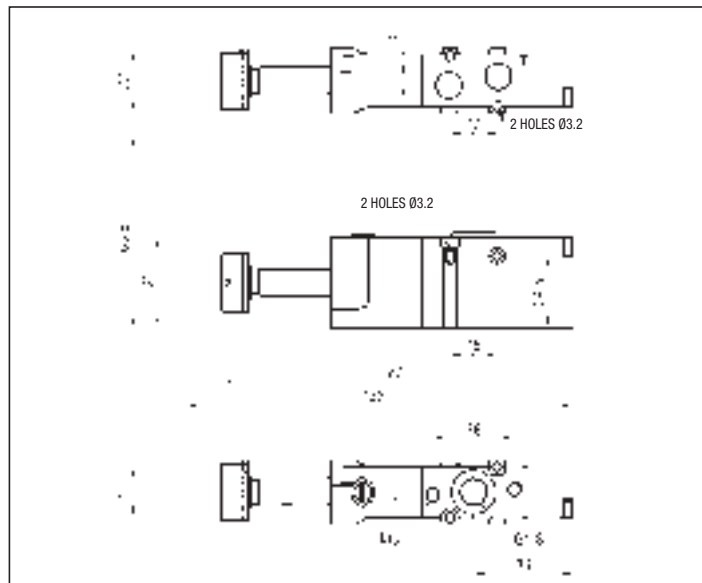

3 PORT BISTABLE

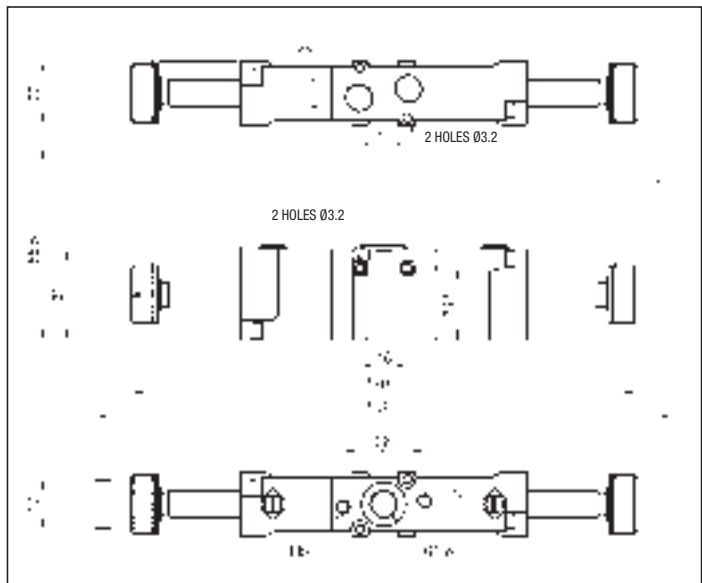

2

SOLENOID ACTUATED VALVES WITH 15 mm COIL G 1/8 - 5 PORT

Symbol	Function	Controls		Response time at 6 bar (ms)		Flow rate at 6 bar ΔP = 1 bar (l/min)	Weight (g)	TYPE*
		Pilot	Returns	Energized	De-energized			
	5/2 monostable	Solenoid	Pneumomechanical spring	13	38	750	140	SKCA815 KUC/ZQ
		Solenoid	Pneumatic spring					SKCA815 KUC/TQ
		Solenoid pilot assisted	Pneumomechanical spring					SKCA815 KUR/ZQ
	5/2 bistable	Solenoid	Solenoid	11	11	750	170	SKCA815 KUC/KUC
		Solenoid pilot assisted	Solenoid pilot assisted					SKCA815 KUR/KUR
	5/3 closed centre	Solenoid	Mechanical spring	15	17	600	184	SKCA815 SUC/SUC
		Solenoid pilot assisted	Mechanical spring					SKCA815 SUR/SUR
	3/2 N.O. + 3/2 N.O. monostable	Solenoid	Mechanical spring	15	17	600	184	SKA+A815 KUC/ZR
		Solenoid pilot assisted	Mechanical spring					SKA+A815 KUR/ZR
	3/2 N.O. + 3/2 N.C. monostable	Solenoid	Mechanical spring	15	17	600	184	SKA+C815 KUC/ZR
		Solenoid pilot assisted	Mechanical spring					SKA+C815 KUR/ZR
	3/2 N.C. + 3/2 N.O. monostable	Solenoid	Mechanical spring	15	17	600	184	SKC+A815 KUC/ZR
		Solenoid pilot assisted	Mechanical spring					SKC+A815 KUR/ZR
	3/2 N.C. + 3/2 N.C. monostable	Solenoid	Mechanical spring	15	17	600	184	SKC+C815 KUC/ZR
		Solenoid pilot assisted	Mechanical spring					SKC+C815 KUR/ZR

* SPECIFY THE VOLTAGE IN THE ORDER - E.G.: **SKCA815 KUC/ZQ 02450-60**

02400 = 24 V DC
02450-60 = 24 V AC

11050-60 = 110 V AC
22050-60 = 220 V AC

/EX Consistent with the ATEX directive II 3G c Ex nA IIC T5 Gc -5°C≤T_a≤50°C
II 3D c Ex tc IIC T100°C IP65 Dc

E.G.: **SKCA815 KUC/ZQ 02450-60/EX**

5 PORT MONOSTABLE

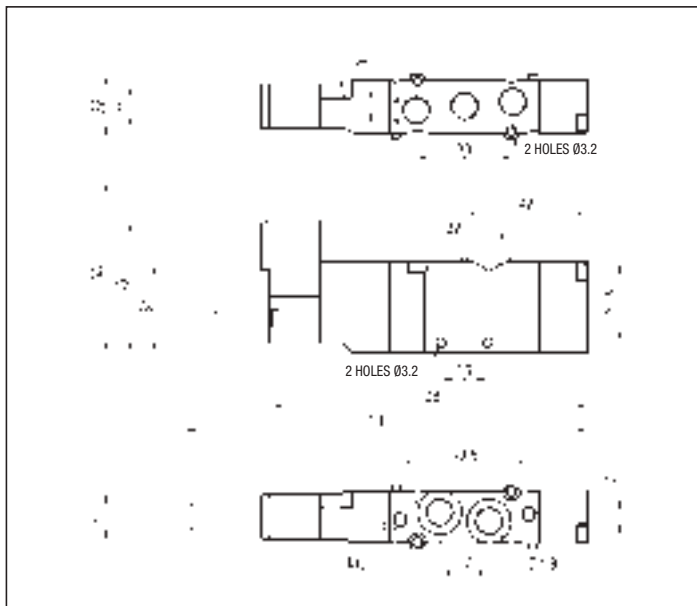

3+3 AND 5 PORT 2 AND 3 POSITIONS

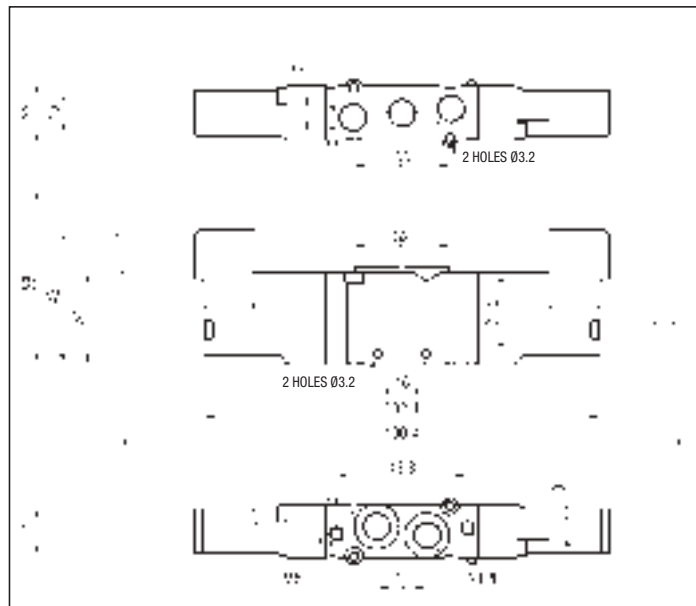

2

2

SOLENOID ACTUATED VALVES WITH Ø 9 mm SLEEVE G 1/8 - 5 PORT

Symbol	Function	Controls		Response time at 6 bar (ms)		Flow rate at 6 bar ΔP = 1 bar (Nl/min)	Weight (g)	TYPE*
		Pilot	Returns	Energized	De-energized			
	5/2 monostable	Solenoid	Pneumomechanical spring	13	38	750	130	SKCA822 KUC/ZQ
		Solenoid	Pneumatic spring					SKCA822 KUC/TQ
		Solenoid pilot assisted	Pneumomechanical spring					SKCA822 KUR/ZQ
	5/2 bistable	Solenoid	Solenoid	11	11	750	160	SKCA822 KUC/KUC
		Solenoid pilot assisted	Solenoid pilot assisted					SKCA822 KUR/KUR
	5/3 closed centre	Solenoid	Mechanical spring	15	17	600	170	SKCA822 SUC/SUC
		Solenoid pilot assisted	Mechanical spring					SKCA822 SUR/SUR
	3/2 N.O. + 3/2 N.O. monostable	Solenoid	Mechanical spring	15	17	600	170	SKA+A822 KUC/ZR
		Solenoid pilot assisted	Mechanical spring					SKA+A822 KUR/ZR
	3/2 N.O. + 3/2 N.C. monostable	Solenoid	Mechanical spring	15	17	600	170	SKA+C822 KUC/ZR
		Solenoid pilot assisted	Mechanical spring					SKA+C822 KUR/ZR
	3/2 N.C. + 3/2 N.O. monostable	Solenoid	Mechanical spring	15	17	600	170	SKC+A822 KUC/ZR
		Solenoid pilot assisted	Mechanical spring					SKC+A822 KUR/ZR
	3/2 N.C. + 3/2 N.C. monostable	Solenoid	Mechanical spring	15	17	600	170	SKC+C822 KUC/ZR
		Solenoid pilot assisted	Mechanical spring					SKC+C822 KUR/ZR

* THE TYPES OF THE SOLENOID VALVE DO NOT INCLUDE COILS

/EX Consistent with the ATEX directive II 2GD c T5 T100°C -10°C ≤ Ta ≤ 60°C E.G.: SKCA822 KUC/ZQ

5 PORT MONOSTABLE

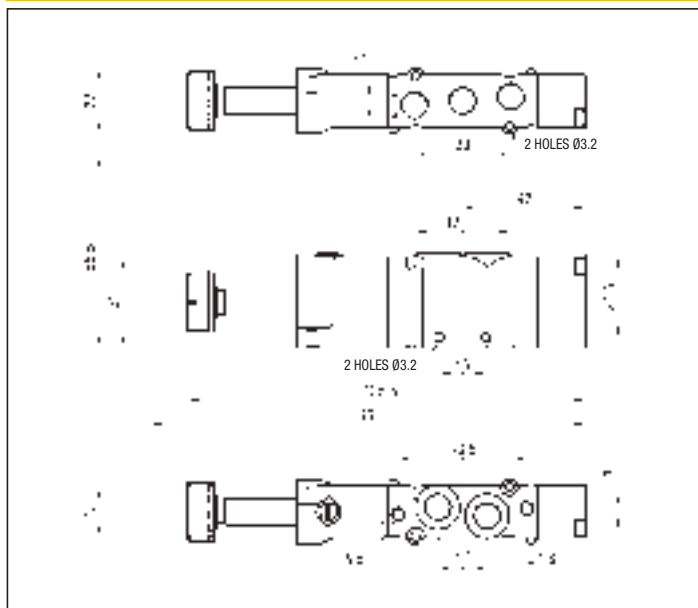

3+3 PORT, 5 PORT BISTABLE 3 POSITIONS

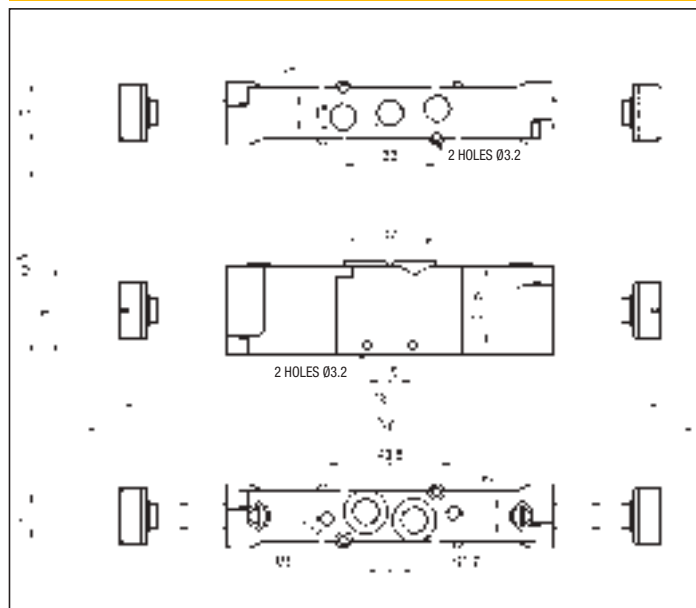

2

2

BASE FOR MANIFOLD MOUNTING OF VALVES G 1/8 - KB/SK8

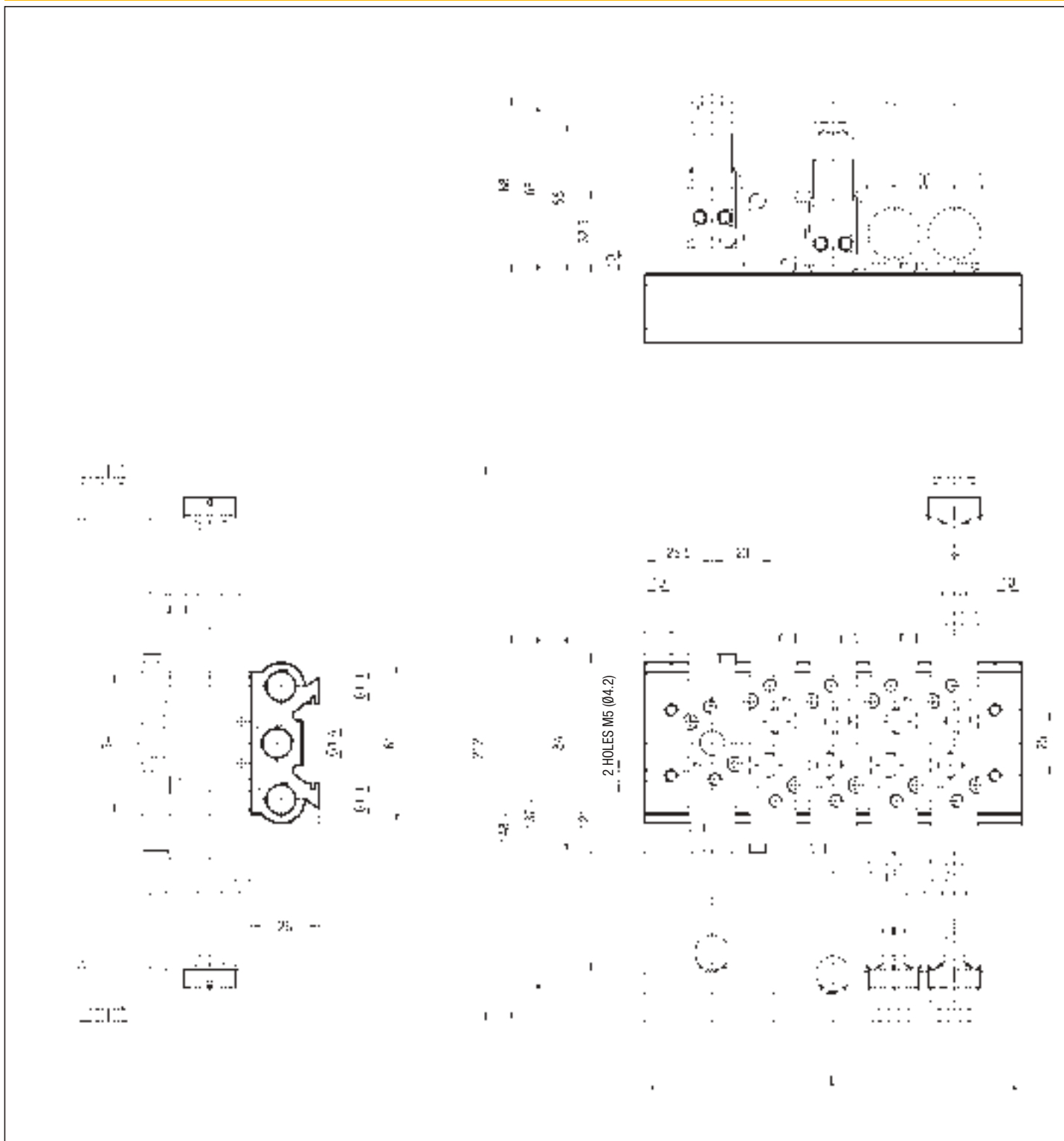

No of stations	2	3	4	5	6	8	10	12	14	16	18	20
L	74	97	120	143	166	212	258	304	350	396	442	488
Weight (g)	170	221	272	323	374	476	578	680	782	884	986	1088
TYPE*	KB/SK8/2	KB/SK8/3	KB/SK8/4	KB/SK8/5	KB/SK8/6	KB/SK8/8	KB/SK8/10	KB/SK8/12	KB/SK8/14	KB/SK8/16	KB/SK8/18	KB/SK8/20

*BASES ARE SUPPLIED COMPLETE WITH SCREWS AND SEALS

P.S.: ALSO 3 PORT VALVES ON THIS BASE CAN BE MOUNTED USING THE ADAPTER "KIT/A/SK8"

BLANKING PLATE - KIT/PC/SK8

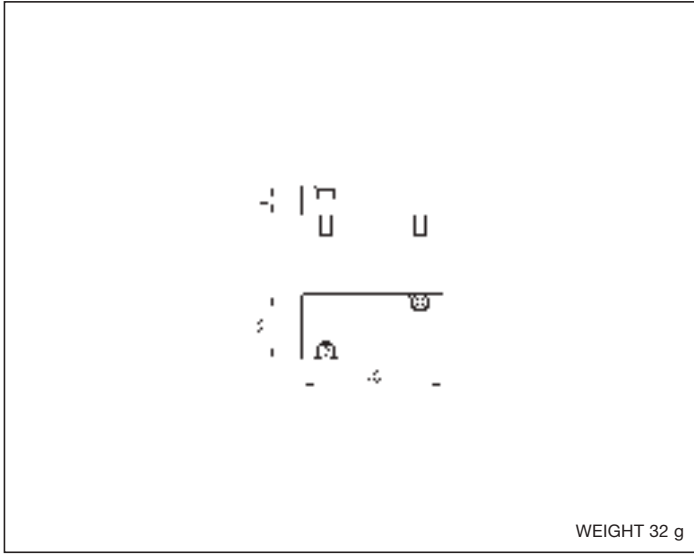

BLANKING PLATE IS SUPPLIED COMPLETE WITH SCREWS AND SEALS

ADAPTER FOR MOUNTING SK 3 PORT - KIT/A/SK8

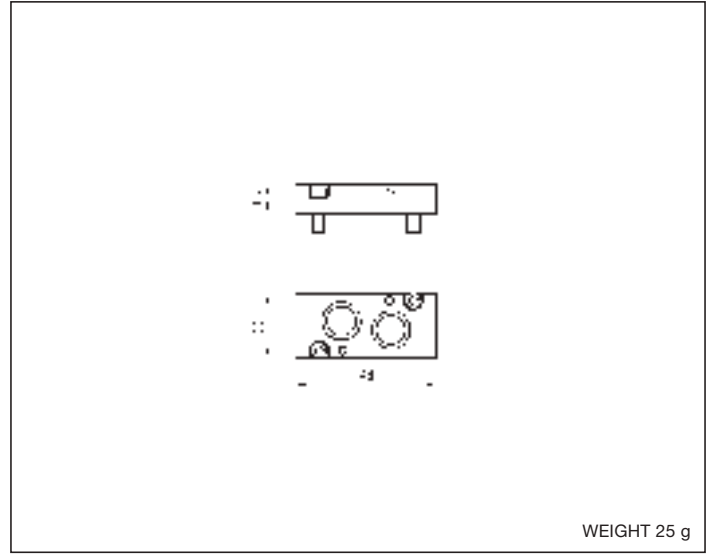

ADAPTER IS SUPPLIED COMPLETE WITH SCREWS AND SEALS

series MEV

Spool compact valves pilot and solenoid actuated G 1/8 and to ISO 15407-2 standard (VDMA 24563) size 02

DESCRIPTION

Valves series "MEV" have been designed to satisfy the need of integration between pneumatics and electronics. Their main feature is the possibility to offer valve islands complete with the electrical connection. This series, realized in the 5/2 and 5/3 pneumatic functions, is composed of two types of valves: "MEV 8", body ported G 1/8, prearranged for both single use and for mounting on multiple base with fixed stations; "MEV 18" (size 02), to ISO 15407-2 (VDMA 24563 - UNI 10528) standards, prearranged for mounting on both single and manifold bases.

Both the multiple bases (that convey the exhausts port of the solenoid actuated electropilots) and the manifold ones are fit for mounting onto rails according to DIN 46277/3. For the 24 V AC/DC solenoid actuated valves with coils toward the bottom (versions "MEVX"), are available modules with two or four stations to carry out a multi-pin connection through a 25-pin plug with protection class "IP 65" (see technical information on page 0.7). Upon request, they can be supplied in compliance with ATEX directive, category 3GD for electrical version and 2GD for pneumatic ones.



TECHNICAL DATA

Operating pressure	Monostabile: 1,8 ÷ 8 bar Bistabile: 1 ÷ 8 bar
Working temperature	0 ÷ +60 °C (-10 °C with dry air)
Fluid	Compressed air, filtered, continuous lubricated, unlubricated or dry lubricated
Port size	G 1/8 Size 02 = Interface to VDMA 24563 standard
Pneumatic piloting port size	G 1/8 = M5 Size 02 = Interface to VDMA 24563 standard
Nominal diameter	5 mm
Piloting solenoid valve	UMCSV - see chapter direct acting solenoid valves on page 2.5
Electric connectors	MEK192/N - see chapter connectors on page 2.18 see multi-pin connection on page 2.42

MATERIALS

Bottoms	Techno-polymer
Body	Anodized aluminium alloy
Springs	Stainless steel
Seals	NBR rubber
Spool	Anodized aluminium alloy
Piston	Anodized aluminium alloy

SPARE PARTS

SEALS KIT	
5/2 monostable and bistable	MEV/SG
5/3 closed centre	MEV/CC/SG
5/3 open centre	MEV/CA/SG
5/3 pressure centre	MEV/CP/SG

FLOW CHART MEV/8

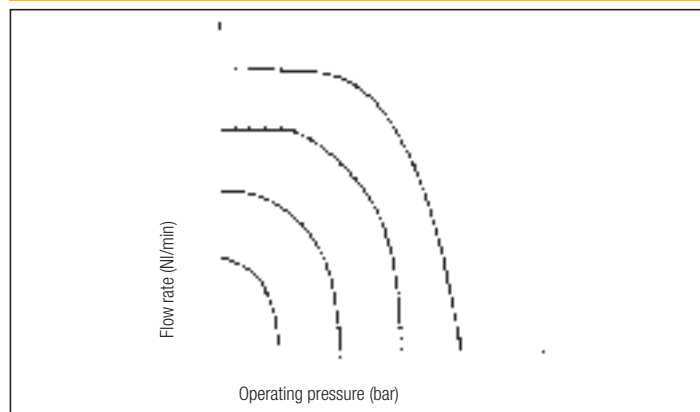

PILOTING CHART MEV/8 - MEV/18

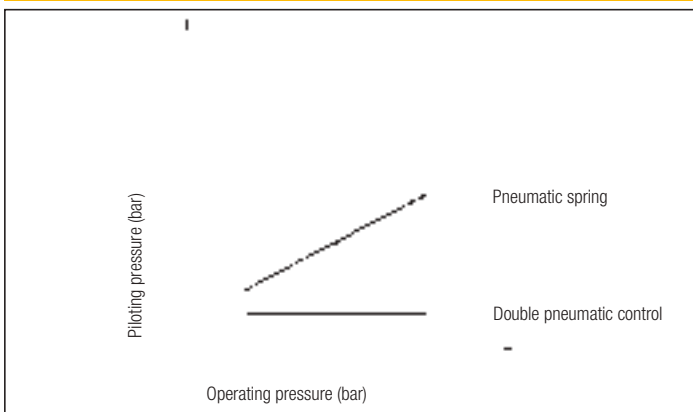

FLOW CHART MEV/18

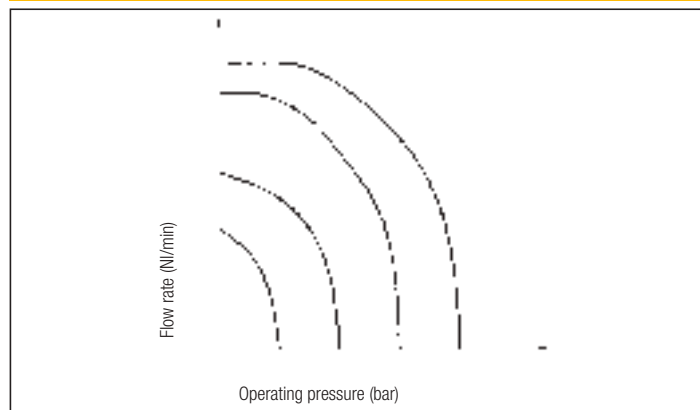

PILOT ACTUATED VALVES G 1/8 - MEV 8

Symbol	Function	Controls		Response time at 6 bar (ms)		Flow rate at 6 bar $\Delta P = 1 \text{ bar (Nl/min)}$	Weight (g)	TYPE*
		Pilot	Return	Energized	De-energized			
	5/2 monostable	Pneumatic	Pneumomechanical spring	10	10	650	100	MEV8 KR/ZQ
		Pneumatic	Pneumatic spring	12	20	650	100	MEV8 KR/TQ
	5/2 bistable	Pneumatic	Pneumatic	10	10	650	100	MEV8 KR/KR
	5/3 closed centre	Pneumatic	Mechanical spring	10	10	510	100	MEV8 SR/SR
	5/3 open centre	Pneumatic	Mechanical spring	10	10	510	100	MEV8 AR/AR
	5/3 pressure centre	Pneumatic	Mechanical spring	10	10	650	100	MEV8 PR/PR

5 PORT - MONOSTABLE

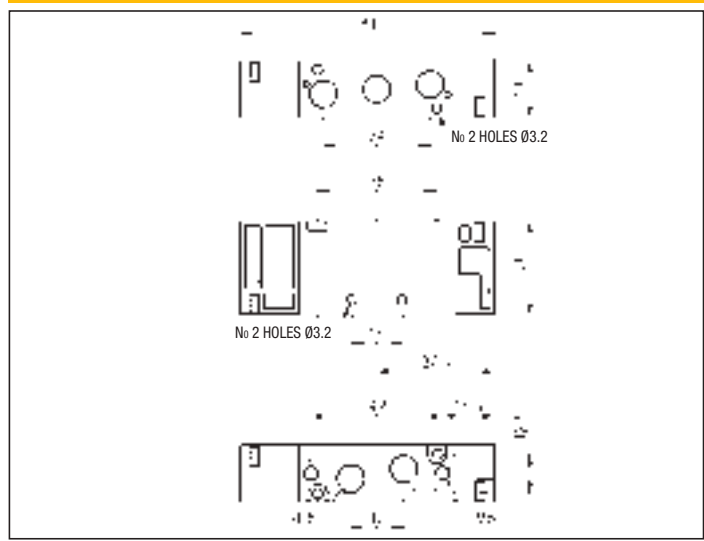

*/EX Consistent with the ATEX directive II 2GD c T5 100°C - 10°C ≤ T_a ≤ 60°C
E.G.: MEV8 KR/ZQ/EX

5 PORT - BISTABLE

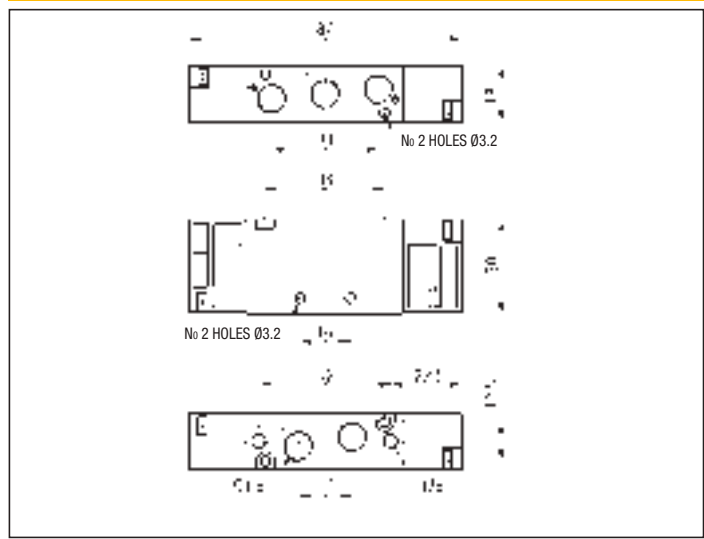

5 PORT - 3 POSITIONS

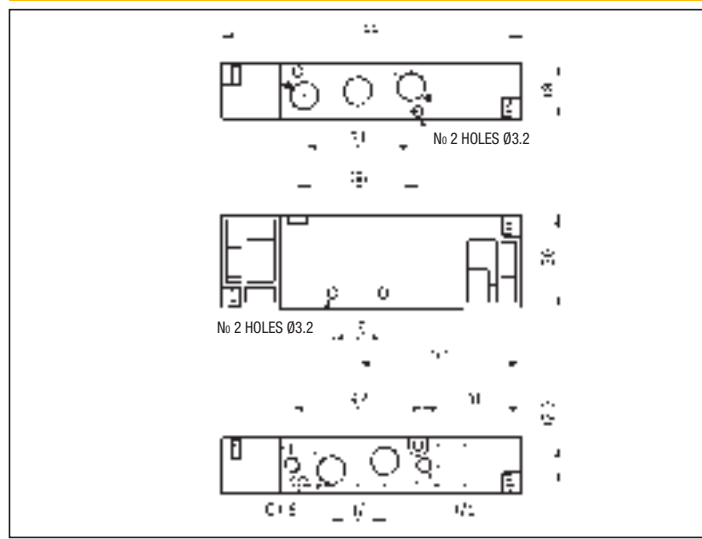

SOLENOID ACTUATED VALVES G 1/8 - MEV 8

Symbol	Function	Controls		Response time at 6 bar (ms)		Flow rate at 6 bar ΔP = 1 bar (NI/min)	Weight (g)	TYPE*
		Pilot	Return	Energized	De-energized			
	5/2 monostable	Solenoid	Pneumomechanical spring	10	30	650	130	MEV8 KUC/ZQ
		Solenoid	Pneumatic spring	10	20			MEV8 KUC/TQ
		Solenoid pilot assisted	Pneumomechanical spring	10	30			MEV8 KUR/ZQ
	5/2 bistable	Solenoid	Solenoid	10	10	650	160	MEV8 KUC/KUC
		Solenoid pilot assisted	Mechanical spring					MEV8 KUR/KUR
	5/3 closed centre	Solenoid	Mechanical spring	10	25	510	160	MEV8 SUC/SUC
		Solenoid pilot assisted	Mechanical spring					MEV8 SUR/SUR
	5/3 open centre	Solenoid	Mechanical spring	10	25	510	160	MEV8 AUC/AUC
		Solenoid pilot assisted	Mechanical spring					MEV8 AUR/AUR
	5/3 pressure centre	Solenoid	Mechanical spring	10	25	650	160	MEV8 PUC/PUC
		Solenoid pilot assisted	Mechanical spring					MEV8 PUR/PUR

* SPECIFY THE VOLTAGE IN THE ORDER - E.G.: **MEV8 KUC/ZQ 02400**

02400 = 24 V DC
02450-60 = 24 V AC

11050-60 = 110 V AC
22050-60 = 220 V AC

*/EX Consistent with the ATEX directive II 3G c Ex nA IIC T5 Gc -5°C ≤ Ta ≤ 50°C
II 3D c Ex tc IIIC T100°C IP65 Dc

E.G.: **MEV8 KUC/ZQ 02400/EX**

5 PORT - MONOSTABLE

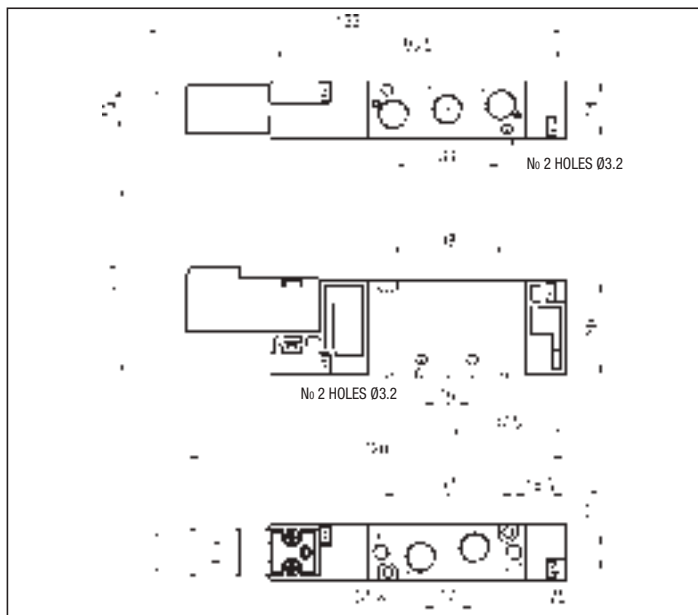

5 PORT - BISTABLE

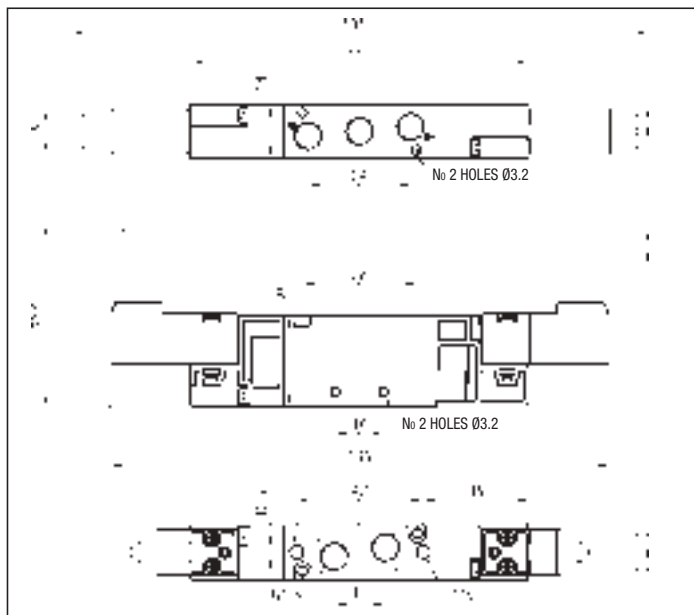

5 PORT - 3 POSITIONS

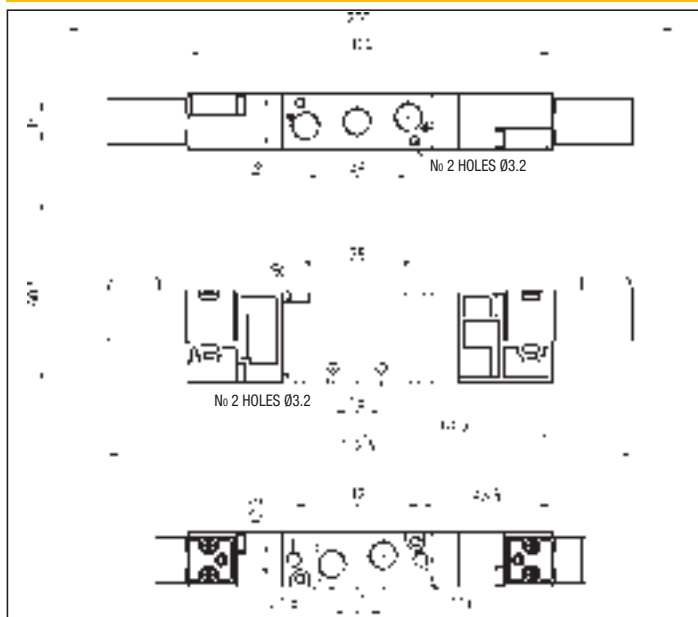

**SOLENOID ACTUATED VALVES WITH COILS TOWARD THE BOTTOM G 1/8 - MEVX 8
SUITABLE FOR SINGLE USE OR MULTI-PIN PLUG CONNECTOR**

2

Symbol	Function	Controls		Response time at 6 bar (ms)		Flow rate at 6 bar $\Delta P = 1 \text{ bar (Nl/min)}$	Weight (g)	TYPE*
		Pilot	Return	Energized	De-energized			
	5/2 monostable	Solenoid	Pneumomechanical spring	10	30	650	130	MEVX8 KUC/ZQ
		Solenoid	Pneumatic spring	10	20			MEVX8 KUC/TQ
		Solenoid pilot assisted	Pneumomechanical spring	10	30			MEVX8 KUR/ZQ
	5/2 bistable	Solenoid	Solenoid	10	10	650	175	MEVX8 KUC/KUC
		Solenoid pilot assisted	Solenoid pilot assisted					MEVX8 KUR/KUR
	5/3 closed centre	Solenoid	Mechanical spring	10	25	510	175	MEVX8 SUC/SUC
		Solenoid pilot assisted	Mechanical spring					MEVX8 SUR/SUR
	5/3 open centre	Solenoid	Mechanical spring	10	25	510	175	MEVX8 AUC/AUC
		Solenoid pilot assisted	Mechanical spring					MEVX8 AUR/AUR
	5/3 pressure centre	Solenoid	Mechanical spring	10	25	650	175	MEVX8 PUC/PUC
		Solenoid pilot assisted	Mechanical spring					MEVX8 PUR/PUR

* SPECIFY THE VOLTAGE IN THE ORDER
E.G.: MEVX8 KUC/ZR 02400

02400 = 24 V DC
02450-60 = 24 V AC

*EX Consistent with the ATEX directive
E.G.: MEVX8 KUC/ZQ 02400/EX



II 3G c Ex nA IIC T5 Gc -5°C ≤ Ta ≤ 50°C
II 3D c Ex tc IIIC T100°C IP65 Dc

5 PORT - MONOSTABLE

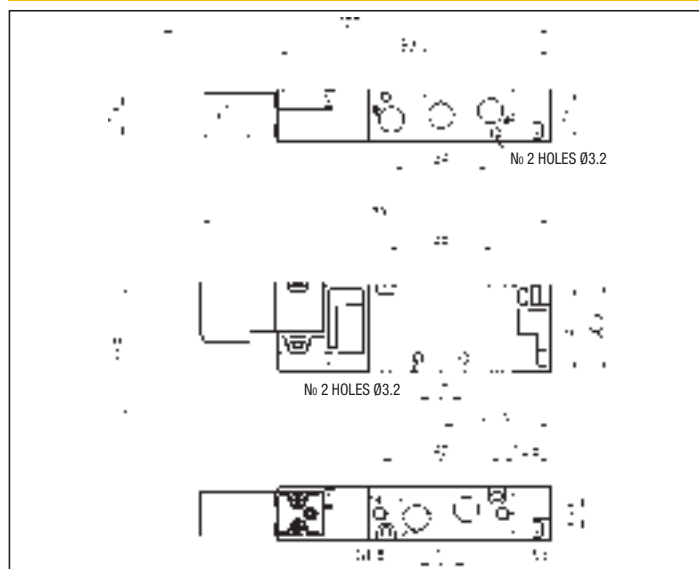

5 PORT - BISTABLE AND 5 PORT - 3 POSITIONS

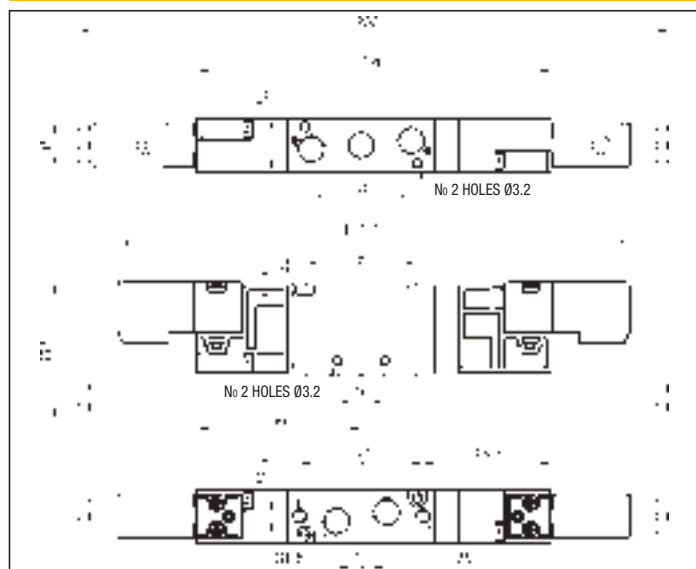

BASE FOR MANIFOLD MOUNTING OF VALVES G 1/8 - KB/MEV8 - Fit for mounting onto DIN 46277/3 rail

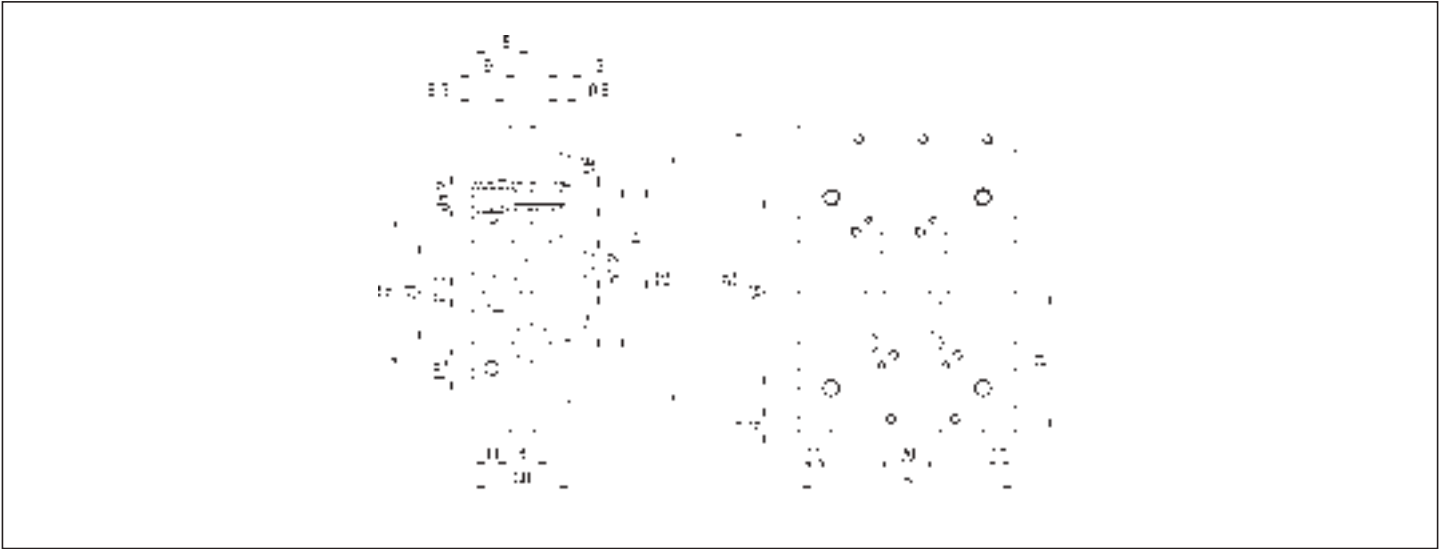

No of stations	2	3	4	5	6	8	10	12	14	16	18
A	67	87	107	127	147	187	227	267	307	347	387
Weight (g)	324	421	518	615	712	905	1098	1292	1486	1680	1873
TYPE*	KB/MEV8/2	KB/MEV8/3	KB/MEV8/4	KB/MEV8/5	KB/MEV8/6	KB/MEV8/8	KB/MEV8/10	KB/MEV8/12	KB/MEV8/14	KB/MEV8/16	KB/MEV8/18

*BASES ARE SUPPLIED COMPLETE WITH SCREWS AND SEALS

BLANKING PLATE - MEV8/PC

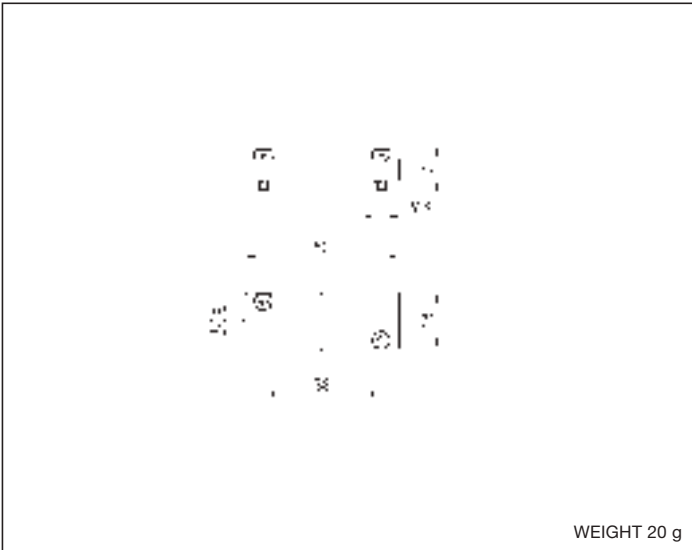

BLANKING PLATE IS SUPPLIED COMPLETE WITH SCREWS AND SEALS

FIXING PLATE FOR DIN 46277/3 RAIL - MEV8/PF

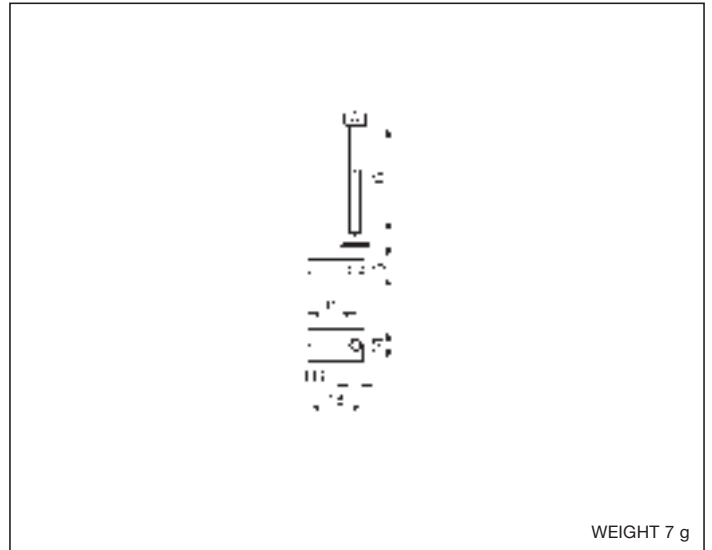

FIXING PLATE IS SUPPLIED COMPLETE WITH SCREWS

PILOT ACTUATED VALVES TO ISO 15407-2 STANDARD (VDMA 24563) SIZE 02 - MEV 18

Symbol	Function	Controls		Response time at 6 bar (ms)		Flow rate at 6 bar $\Delta P = 1$ bar (Nl/min)	Weight (g)	TYPE*
		Pilot	Return	Energized	De-energized			
	5/2 monostable	Pneumatic	Pneumomechanical spring	12	50	510	100	MEV18 KR/ZQ
		Pneumatic	Pneumatic spring	20	35	510	100	MEV18 KR/TQ
	5/2 bistable	Pneumatic	Pneumatic	12	12	510	100	MEV18 KR/KR
	5/3 closed centre	Pneumatic	Mechanical spring	15	15	420	100	MEV18 SR/SR
	5/3 open centre	Pneumatic	Mechanical spring	15	15	420	100	MEV18 AR/AR
	5/3 pressure centre	Pneumatic	Mechanical spring	15	15	500	100	MEV18 PR/PR

*EX Consistent with the ATEX directive II 2GD c T5 T100°C - 10°C ≤ Ta ≤ 60°C E.G.: MEV18 KR/ZQ/EX

5 PORT - MONOSTABLE

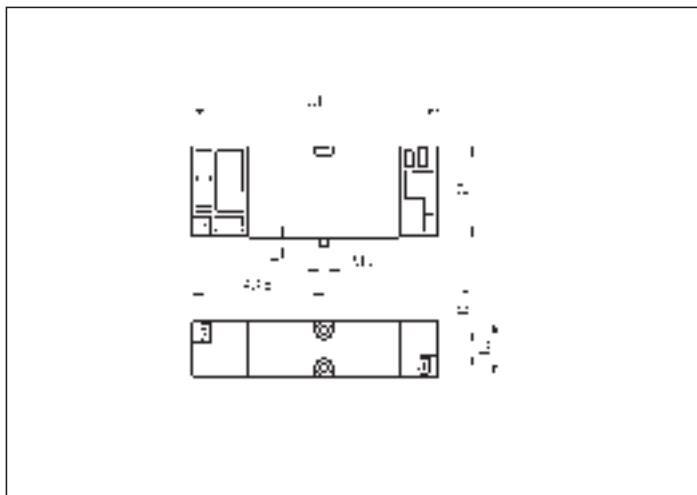

5 PORT - BISTABLE

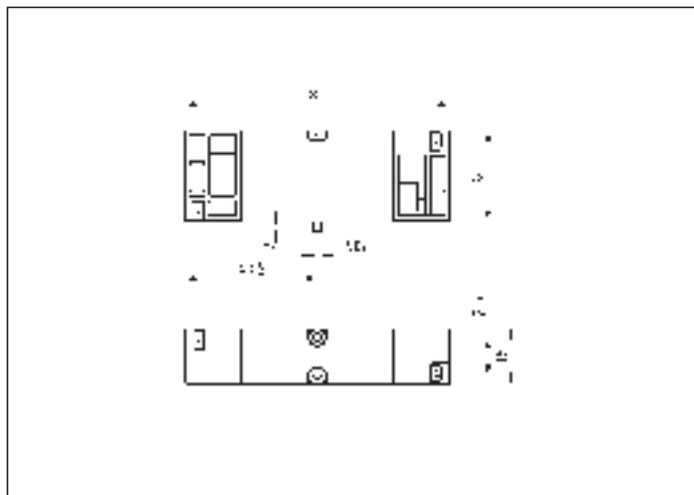

5 PORT - 3 POSITIONS

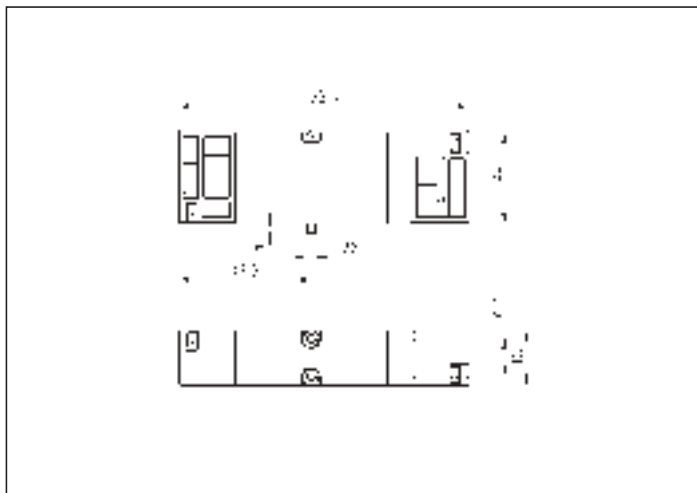

SOLENOID ACTUATED VALVES TO ISO 15407-2 STANDARD (VDMA 24563) SIZE 02 - MEV 18

Symbol	Function	Controls		Response time at 6 bar (ms)		Flow rate at 6 bar $\Delta P = 1$ bar (Nl/min)	Weight (g)	TYPE*
		Pilot	Return	Energized	De-energized			
	5/2 monostable	Solenoid	Pneumomechanical spring	10	50	510	130	MEV18 KUC/ZQ
		Solenoid	Pneumatic spring	12	35			MEV18 KUC/TQ
		Solenoid pilot assisted	Pneumomechanical spring	10	50			MEV18 KUR/ZQ
	5/2 bistable	Solenoid	Solenoid	10	10	510	160	MEV18 KUC/KUC
		Solenoid pilot assisted	Solenoid pilot assisted					MEV18 KUR/KUR
	5/3 closed centre	Solenoid	Mechanical spring	10	30	420	160	MEV18 SUC/SUC
		Solenoid pilot assisted	Mechanical spring					MEV18 SUR/SUR
	5/3 open centre	Solenoid	Mechanical spring	10	30	420	160	MEV18 AUC/AUC
		Solenoid pilot assisted	Mechanical spring					MEV18 AUR/AUR
	5/3 pressure centre	Solenoid	Mechanical spring	10	30	500	160	MEV18 PUC/PUC
		Solenoid pilot assisted	Mechanical spring					MEV18 PUR/PUR

* SPECIFY THE VOLTAGE IN THE ORDER - E.G.: **MEV18 KUC/ZQ 02400**

02400 = 24 V DC

11050-60 = 110 V AC

02450-60 = 24 V AC

22050-60 = 220 V AC

/EX Consistent with the ATEX directive II 3G c Ex nA IIC T5 Gc -5°C ≤ Ta ≤ 50°C
II 3D c Ex tc IIC T100°C IP65 Dc

E.G.: **MEV18 KUC/ZQ 02400/EX**

5 PORT - MONOSTABLE

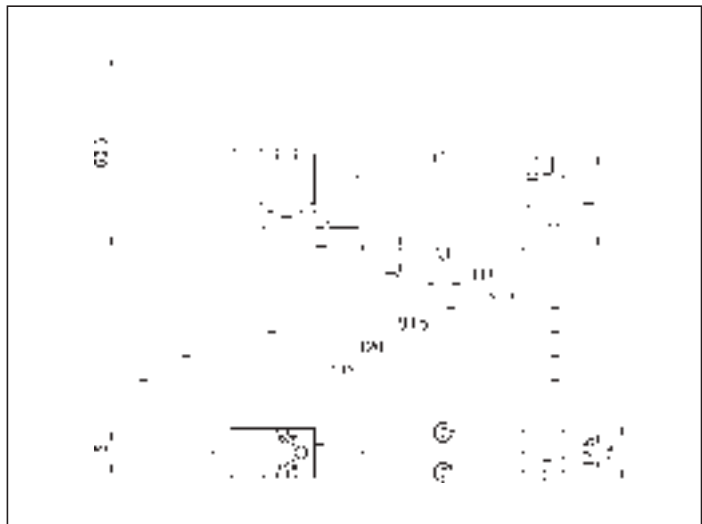

5 PORT - BISTABLE

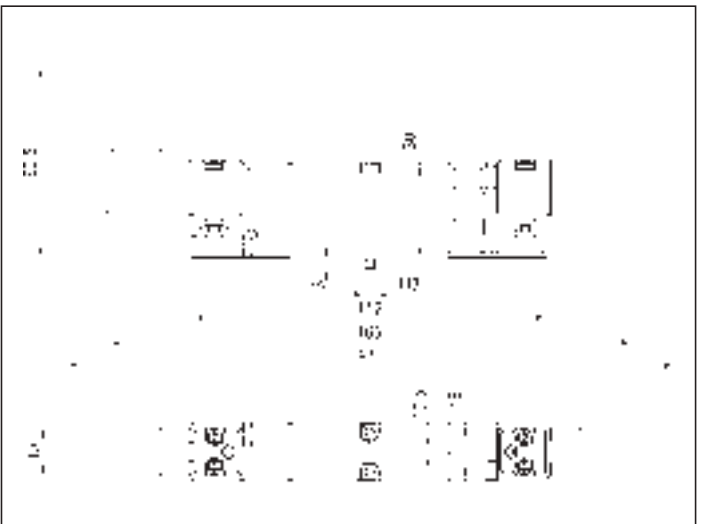

series MEV

Size 02

5 PORT - 3 POSITIONS

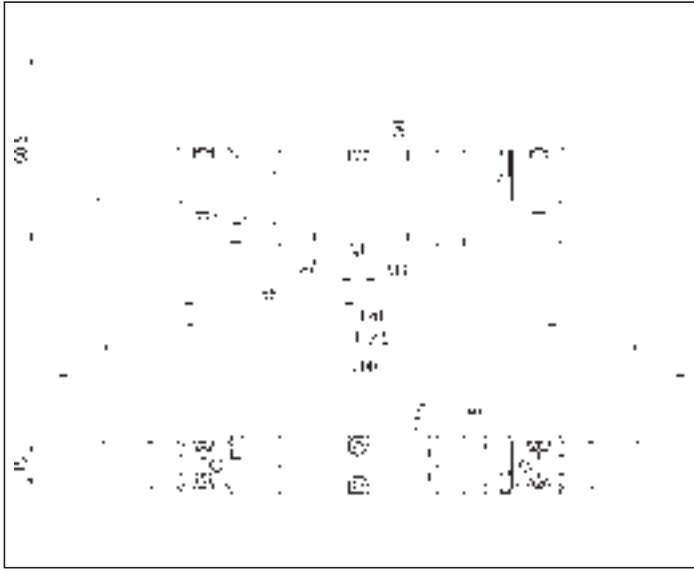

2

SOLENOID ACTUATED VALVES WITH COILS TOWARD THE BOTTOM TO ISO 15407-2 STANDARD (VDMA 24563) SIZE 02 MEVX 18 SUITABLE FOR SINGLE USE OR MULTI-PIN PLUG CONNECTOR

Symbol	Function	Controls		Response time at 6 bar (ms)		Flow rate at 6 bar $\Delta P = 1$ bar (l/min)	Weight (g)	TYPE*
		Pilot	Return	Energized	De-energized			
	5/2 monostable	Solenoid	Pneumomechanical spring	10	50	510	130	MEVX18 KUC/ZQ
		Solenoid	Pneumatic spring	12	35			MEVX18 KUC/TQ
		Solenoid pilot assisted	Pneumomechanical spring	10	50			MEVX18 KUR/ZQ
	5/2 bistable	Solenoid	Solenoid	10	10	510	175	MEVX18 KUC/KUC
		Solenoid pilot assisted	Solenoid pilot assisted					MEVX18 KUR/KUR
	5/3 closed centre	Solenoid	Mechanical spring	10	30	420	175	MEVX18 SUC/SUC
		Solenoid pilot assisted	Mechanical spring					MEVX18 SUR/SUR
	5/3 open centre	Solenoid	Mechanical spring	10	30	420	175	MEVX18 AUC/AUC
		Solenoid pilot assisted	Mechanical spring					MEVX18 AUR/AUR
	5/3 pressure centre	Solenoid	Mechanical spring	10	30	500	175	MEVX18 PUC/PUC
		Solenoid pilot assisted	Mechanical spring					MEVX18 PUR/PUR

* SPECIFY THE VOLTAGE IN THE ORDER - E.G.: **MEVX18 KUC/ZQ 02400**

02400 = 24 V DC

02450-60 = 24 V AC

/EX Consistent with the ATEX directive II 3G c Ex nA IIC T5 Gc -5°C ≤ Ta ≤ 50°C
II 3D c Ex tc IIIC T100°C IP65 Dc

E.G.: **MEVX18 KUC/ZQ 02400/EX**

5 PORT - MONOSTABLE

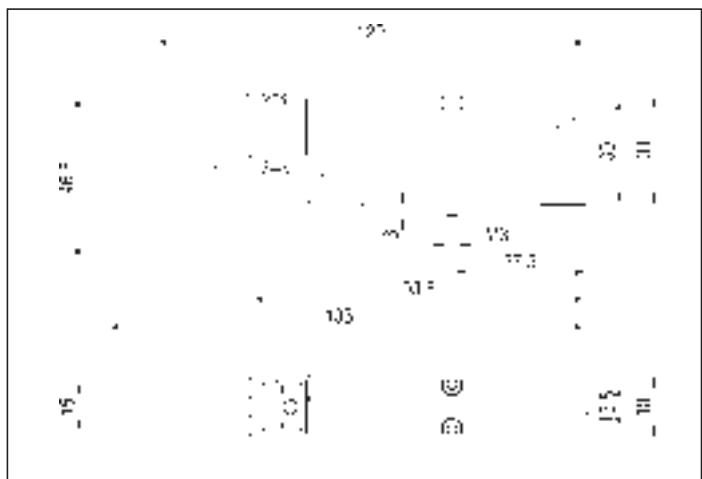

5 PORT - BISTABLE AND 5 PORT - 3 POSITIONS

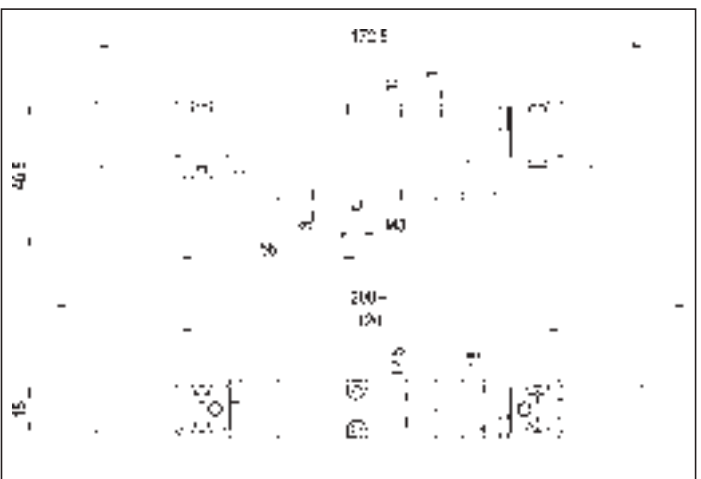

2

INPUT PLATES (PAIR) - MEV18PE

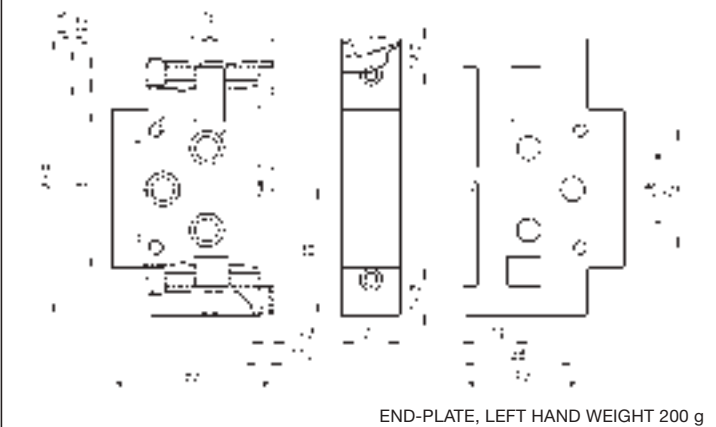

END-PLATE, LEFT HAND WEIGHT 200 g

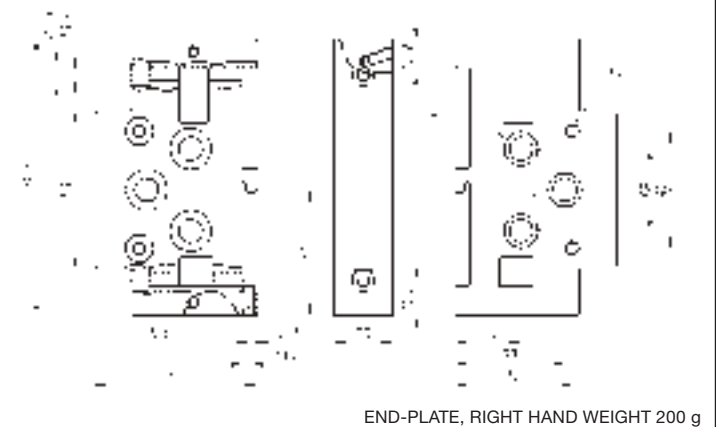

END-PLATE, RIGHT HAND WEIGHT 200 g

INPUT PLATES ARE SUPPLIED COMPLETE WITH SCREWS AND SEALS

MANIFOLD BASE, SIDE PORTED - MEV18BM

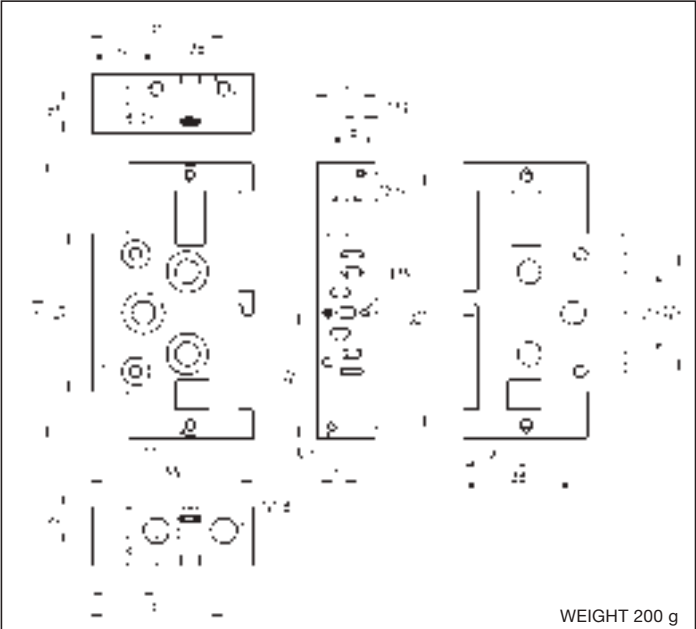

WEIGHT 200 g

MANIFOLD BASE IS SUPPLIED COMPLETE WITH SCREWS AND SEALS

INTERMEDIATE PLATE, TOP PORTED - MEV18PUS

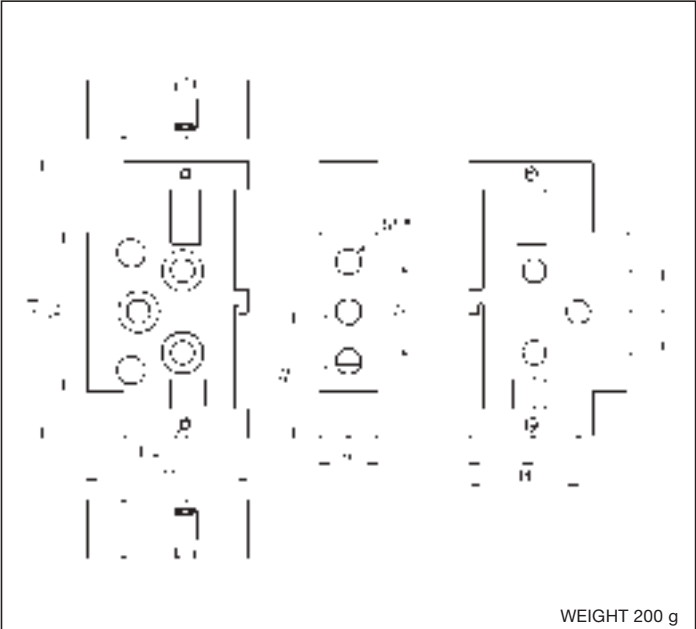

WEIGHT 200 g

INTERMEDIATE PLATE IS SUPPLIED COMPLETE WITH SCREWS AND SEALS

SINGLE BASE SIDE PORTED - MEV18BS

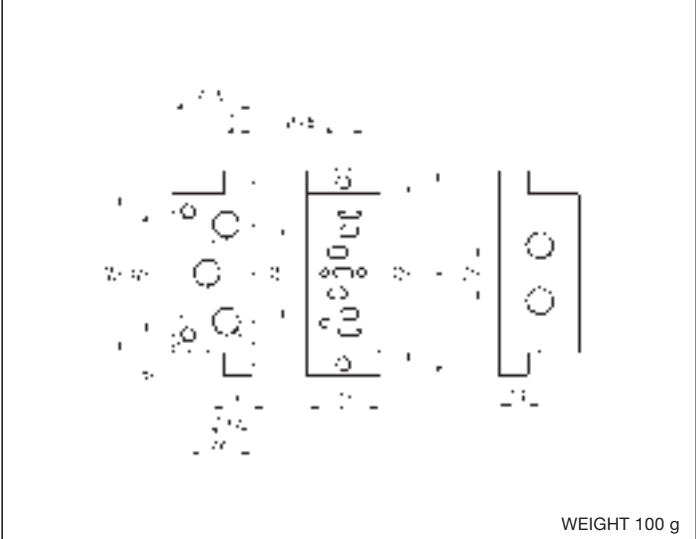

WEIGHT 100 g

BLANKING PLATE - MEV18PC

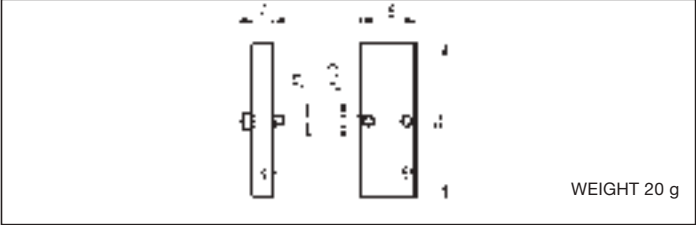

WEIGHT 20 g

BLANKING PLATE IS SUPPLIED COMPLETE WITH SCREWS AND SEALS

DIAPHRAGM - MEV18DG (No. 3 pcs)



DIAPHRAGM - MEV18DP (No. 2 pcs)

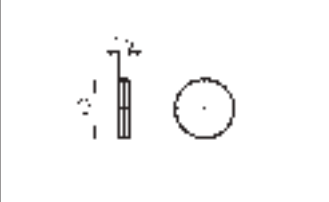

EXAMPLE OF ASSEMBLY - MEV 8 - MEVX 8

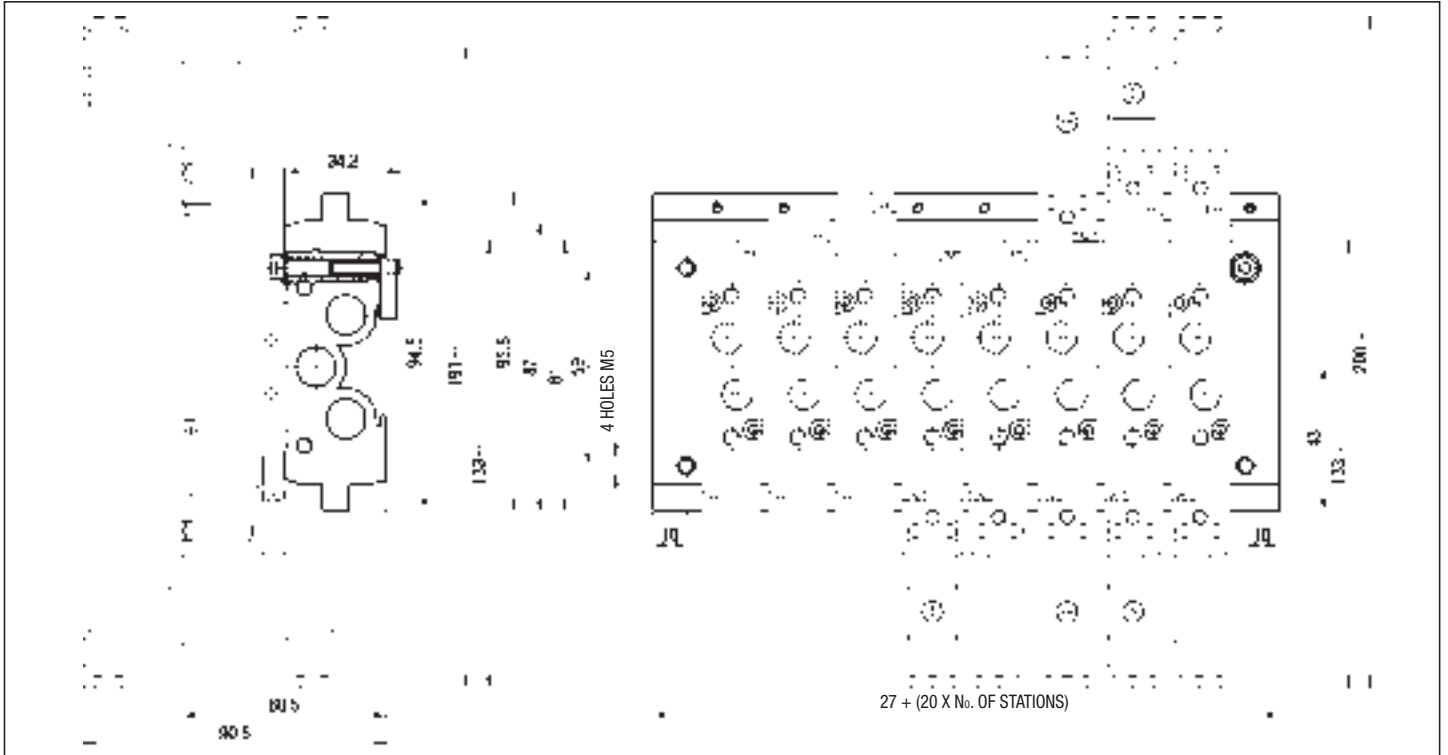

2

EXAMPLE OF ASSEMBLY - MEV 18 - MEVX 18

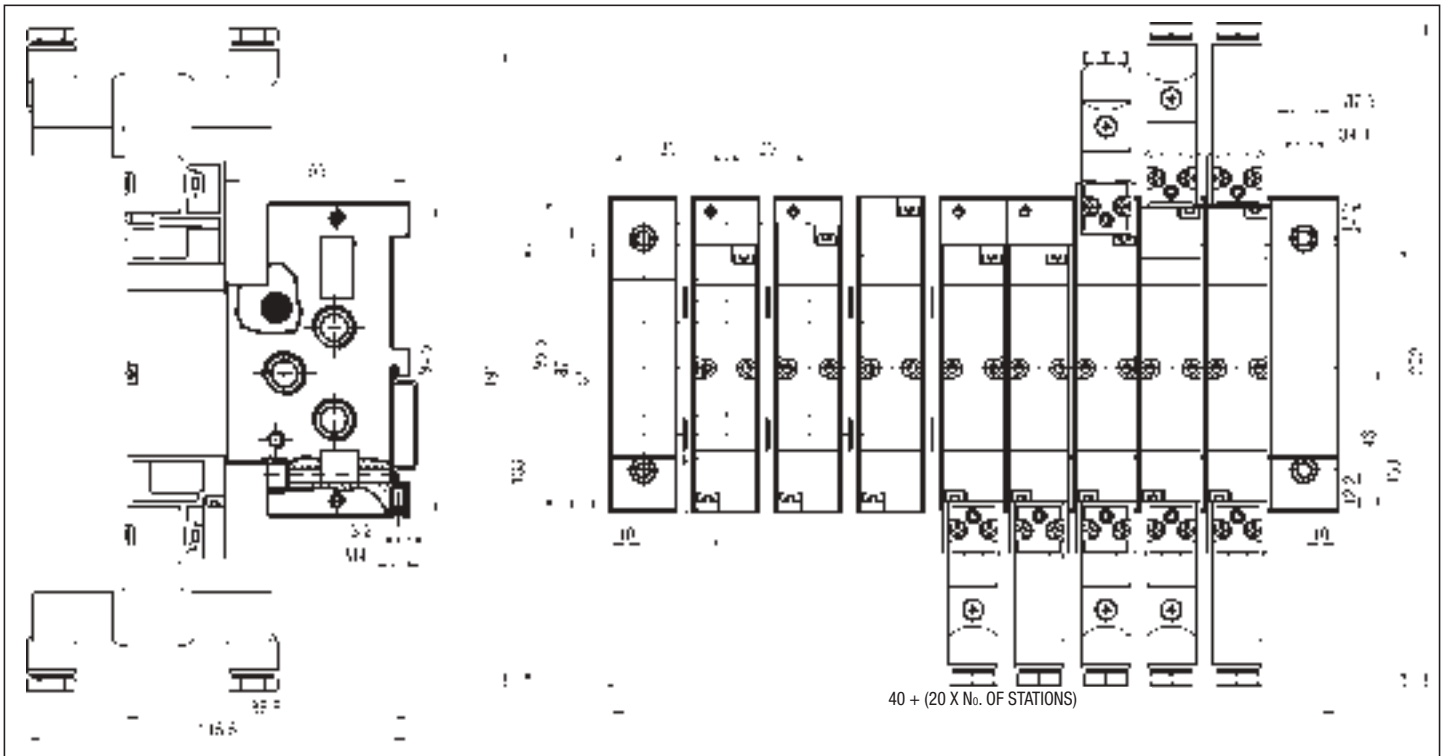

* WITH THE PILOT ACTUATED VALVES USE THE TWO DIAPHRAGMS (TYPE MEV18DP) TO EXCLUDE THE PILOTING EXHAUST (SEE ON PAGE 2.40)

2

25-PIN PLUG, SINGLE - MEV/C1

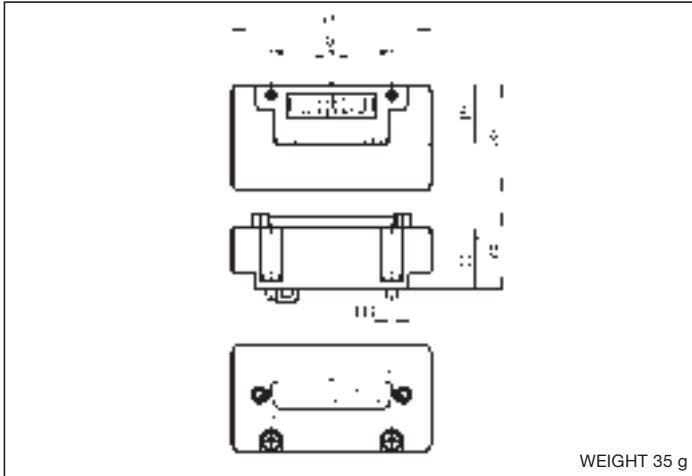

WEIGHT 35 g

25-PIN PLUG, DOUBLE - MEV/C2

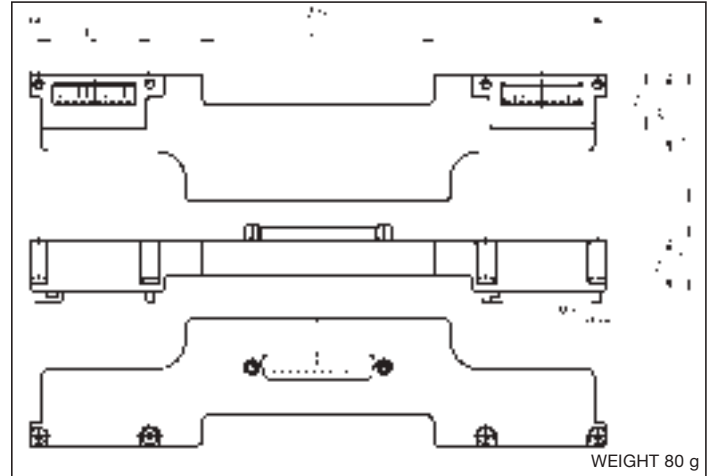

WEIGHT 80 g

TWO STATIONS MODULE, LEFT - MEV/M2S/AC or DC (24 V)

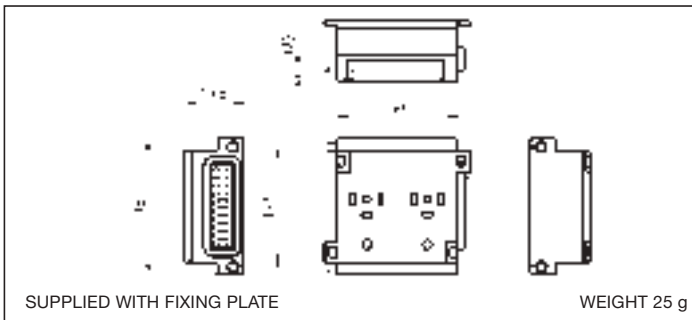

SUPPLIED WITH FIXING PLATE

WEIGHT 25 g

TWO STATIONS MODULE, RIGHT - MEV/M2D/AC or DC (24 V)

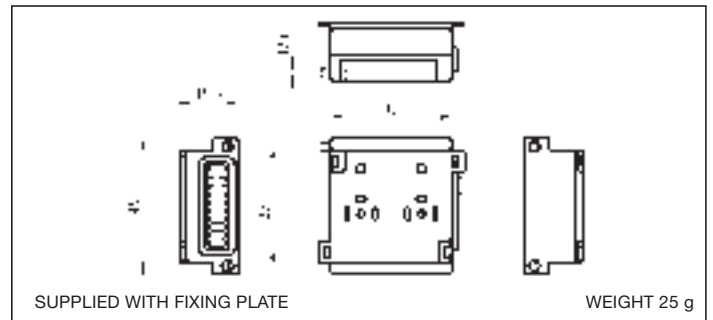

SUPPLIED WITH FIXING PLATE

WEIGHT 25 g

FOUR STATIONS MODULE, LEFT - MEV/M4S/AC or DC (24 V)

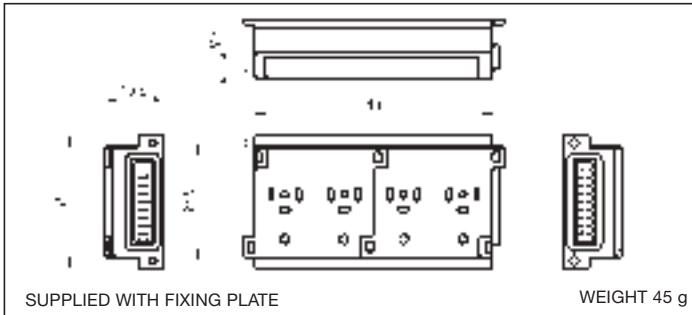

SUPPLIED WITH FIXING PLATE

WEIGHT 45 g

FOUR STATIONS MODULE, RIGHT - MEV/M4D/AC or DC (24 V)

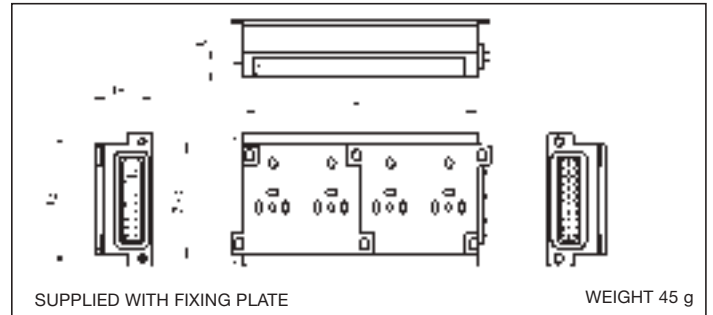

SUPPLIED WITH FIXING PLATE

WEIGHT 45 g

BLANKING CAP - MEV/C

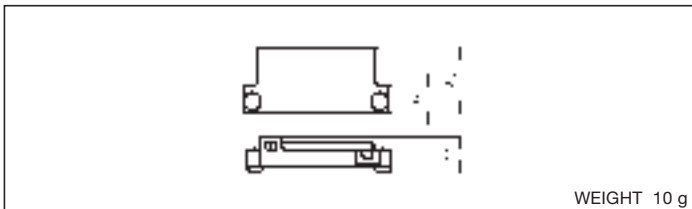

WEIGHT 10 g

PRE-ASSEMBLED MULTI-PIN CABLE "X" METERS LONG WITH 25-PIN SUB-D PLUG

3 m - MEV/CF3; 5 m - MEV/CF5; 10 m - MEV/CF10

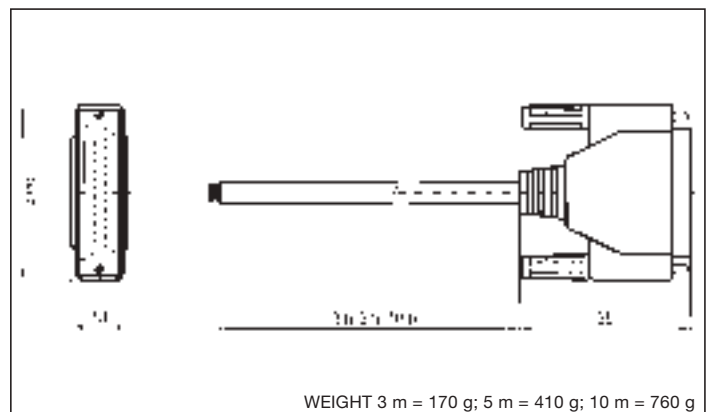

WEIGHT 3 m = 170 g; 5 m = 410 g; 10 m = 760 g

BLANKING PLATE - MEV/PM

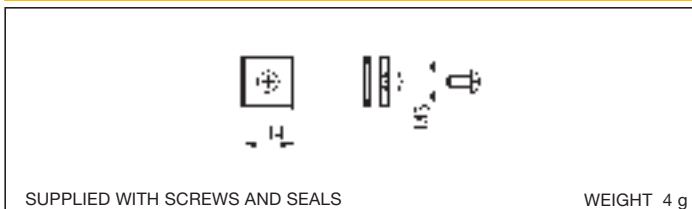

SUPPLIED WITH SCREWS AND SEALS

WEIGHT 4 g

Accessories - Multi-pin connection with solenoid valves versions MEVX 8 and MEVX 18 with cable to IEC 60304 standard

series MEV

2

TECHNICAL INFORMATION

CONNECTION WITH ONE DOUBLE 25-PIN SUB-D PLUG, FOR 2 ÷ 11 STATIONS VALVE ISLANDS

Valve	1		2		3		4		5		6		7		8		9		10		11	
Pilot coil	14(sx)	12(dx)	14(sx)	12(dx)	14(sx)	12(dx)	14(sx)	12(dx)	14(sx)	12(dx)	14(sx)	12(dx)	14(sx)	12(dx)	14(sx)	12(dx)	14(sx)	12(dx)	14(sx)	12(dx)	14(sx)	12(dx)
PIN Number	1	12	2	13	3	14	4	15	5	16	6	17	7	18	8	19	9	20	10	21	11	22
Color	white	red blue	brown	white green	green	brown green	yellow	white yellow	grey	yellow brown	pink	white grey	blue	grey brown	red	white pink	black	pink brown	purple	white blue	grey pink	brown blue

Valve	-		-	
Pilot coil	GND*	GND*	GND*	-
PIN Number	23	24	25	-
Color	white red	brown red	white black	-

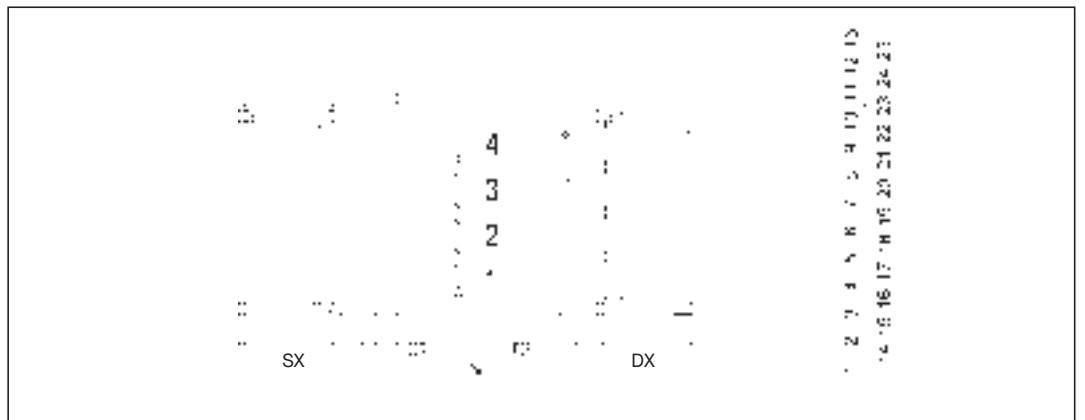

*Common cable

P.S.: For monostable solenoid valves use left modules

CONNECTION WITH TWO SINGLE 25-PIN SUB-D PLUGS, FOR 2 ÷ 16 STATIONS VALVE ISLANDS

Valve	1		2		3		4		5		6		7		8		9		10		11	
Pilot coil	14(sx)	12(dx)	14(sx)	12(dx)	14(sx)	12(dx)	14(sx)	12(dx)	14(sx)	12(dx)	14(sx)	12(dx)	14(sx)	12(dx)	14(sx)	12(dx)	14(sx)	12(dx)	14(sx)	12(dx)	14(sx)	12(dx)
PIN Number	1	1	2	2	3	3	4	4	5	5	6	6	7	7	8	8	9	9	10	10	11	11
Color	white	white	brown	brown	green	green	yellow	yellow	grey	grey	pink	pink	blue	blue	red	red	black	black	purple	purple	grey pink	grey pink

Valve	12		13		14		15		16		-		-		-		-		-	
Pilot coil	14(sx)	12(dx)	14(sx)	12(dx)	14(sx)	12(dx)	14(sx)	12(dx)	14(sx)	12(dx)	GND*	GND*	GND*	GND*	N.C.	N.C.	N.C.	N.C.	N.C.	-
PIN Number	12	12	13	13	14	14	15	15	16	16	17	18	19	20	21	22	23	24	25	-
Color	red blue	red blue	white green	white green	brown green	brown green	white yellow	white yellow	yellow brown	yellow brown	white grey	grey brown	white pink	pink brown	white blue	brown blue	white red	brown red	white black	-

*Common cable

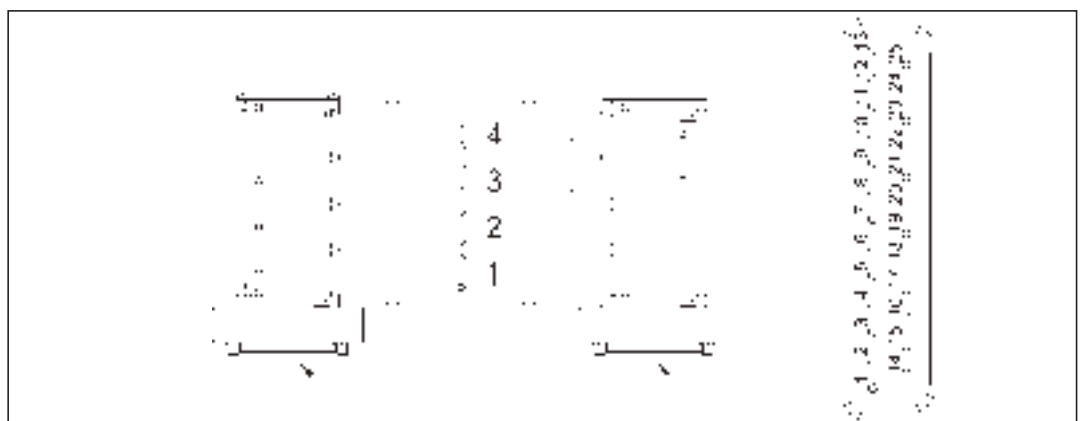

series MEV

Assembling examples Multi-pin connection with solenoid valves versions MEVX 8 and MEVX 18

2

MEVX 8 WITH DOUBLE 25-PIN SUB-D PLUG

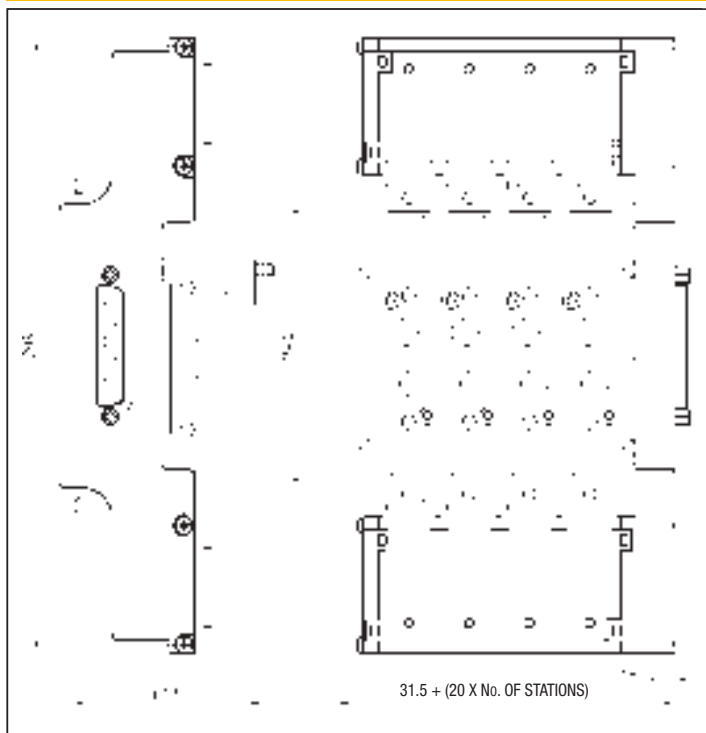

MEVX 8 WITH SINGLE 25-PIN SUB-D PLUG

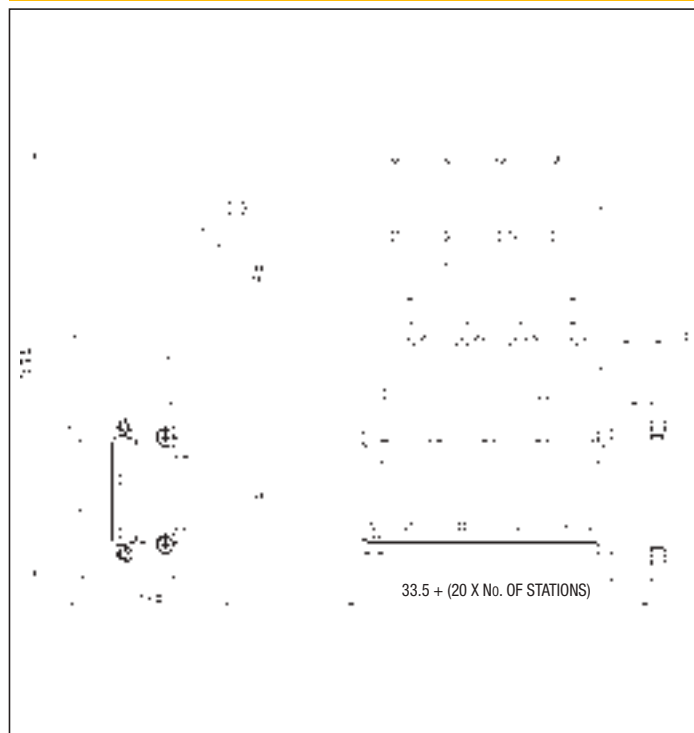

MEVX 18 WITH DOUBLE 25-PIN SUB-D PLUG

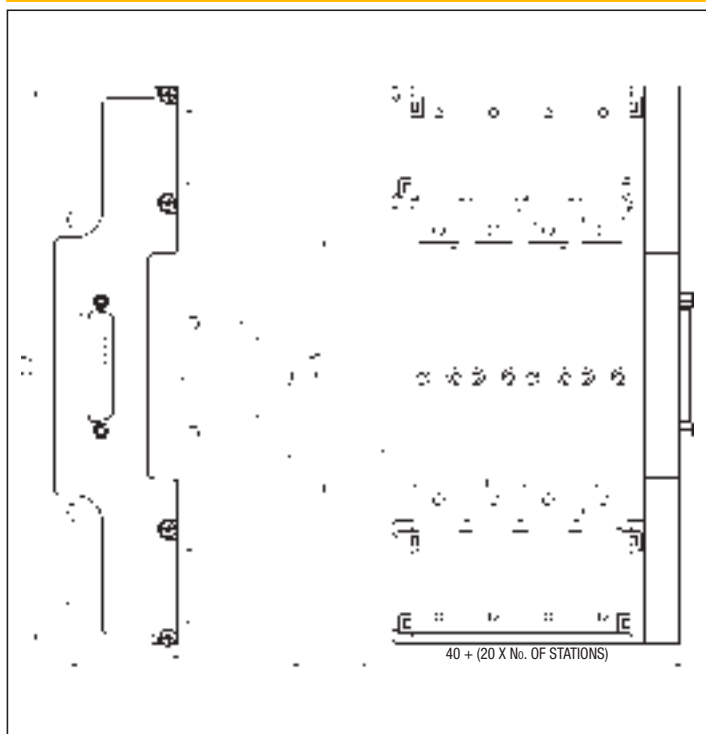

MEVX 18 SINGLE 25-PIN SUB-D PLUG

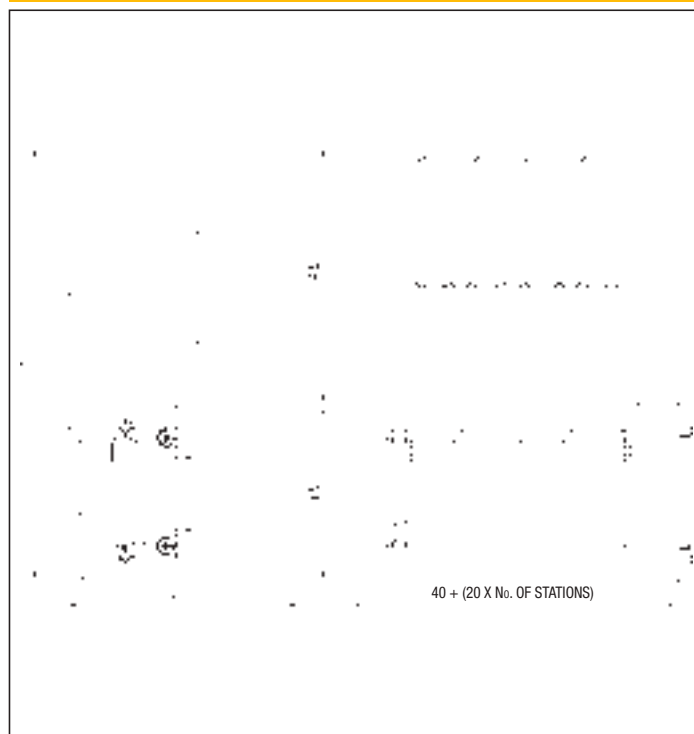

Assembling examples Multi-pin connection with solenoid valves versions MEVX 8 and MEVX 18

series MEV

2

Solenoid valves versions MEVX allow a multi-pin plug connection with the possibility of creating islands of pre-assembled solenoid valves with a number of positions chosen by the user during the assembling of the components.

The replacement of the solenoid valves can be easily made in every moment.

Connection modules are at 2 or 4 positions that can operate with 24 V AC or DC voltage.

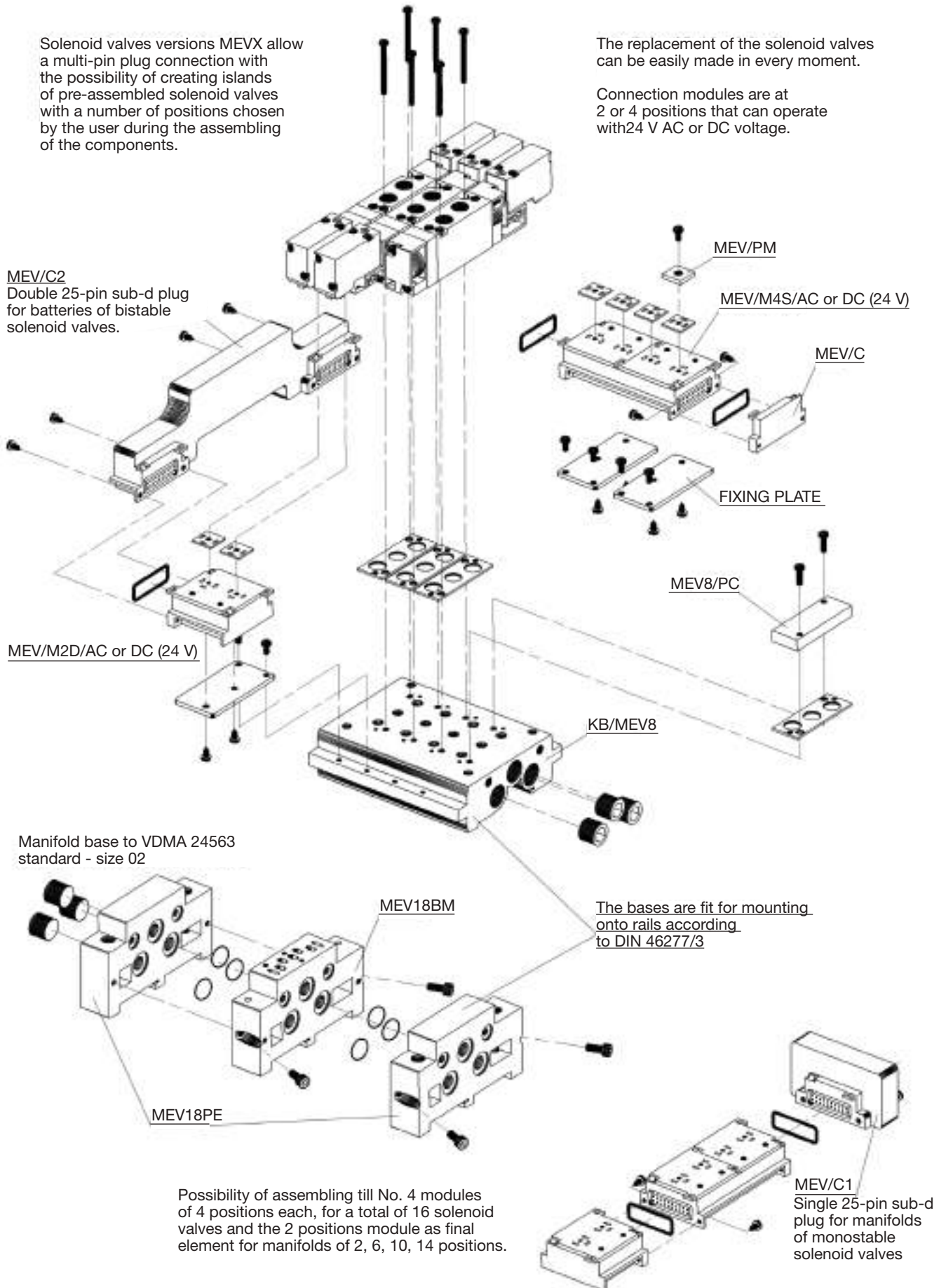

series MEK

Spool compact valves pilot and solenoid actuated G 1/8 - G 1/4

DESCRIPTION

Valves series "MEK", in the 5/2 and 5/3 pneumatic functions, have been realized with compact overall dimensions yet assuring high flow. The kind of construction is based on a balanced spool with dynamic seal thanks to antiglueing mix seals positioned on the same spool. In the solenoid control version, size G 1/8 supports 15 mm low absorption direct acting solenoid valve type UMCSV, while size G 1/4 supports both 15 than 22 mm direct acting solenoid valve type C/USCSV with sleeve Ø 9 mm. This series of valves is prearranged for manifold mounting with fixed stations and with conveyed inlet and exhausts, by means of frontal screws. The bases are fit for mounting onto rails according to DIN 46277/3. Upon request they comply with ATEX directive: 3GD category for the version with the 15 mm piloting solenoid valve and 2GD for all the other ones.



TECHNICAL DATA

Operating pressure	Monostable: 2 ÷ 8 bar Bistable: 1,5 ÷ 8 bar
Working temperature	0 ÷ +60 °C (-10 °C with dry air)
Fluid	Compressed air, filtered, continuous lubricated, unlubricated or dry lubricated
Port size	G 1/8 - G 1/4
Pneumatic piloting port size	M5
Nominal diameter	G 1/8 = 5 mm; G 1/4 = 6,5 mm
Piloting solenoid valve	15 mm: UMCSV per G 1/8 and G 1/4 - see on page 2.5 22 mm: C/USCSV for G 1/4 - see on page 2.14
Coil	USB for G 1/4 - see chapter coils on page 2.17 USBG for G 1/4 - see chapter coils on page 2.17* USBG2 for G 1/4 - see chapter coils on page 2.17*
Electric connectors	MEK192/N for G 1/8 and G 1/4 with UMCSV; USR102/N9 for G 1/4 with C/USCSV ULR1B for G 1/4 with C/USCSV* See chapter connectors on page 2.18

* Only for valve individually used (coil and connector protrude from the dimensions of the valves)

MATERIALS

Bottoms	Anodized aluminium alloy
Body	Anodized aluminium alloy
Springs	Stainless steel
Seals	NBR rubber
Spool	Anodized aluminium alloy
Piston	Anodized aluminium alloy

SPARE PARTS

SEALS KIT	
5/2 monstable and bistable - G1/8	MEK/SG/8
5/3 closed centre - G1/8	MEK/CC/SG/8
5/3 open centre - G1/8	MEK/CA/SG/8
5/3 pressure centre - G1/8	MEK/CP/SG/8
5/2 monstable e bistable - G1/4	MEK/SG/4
5/3 closed centre - G1/4	MEK/CC/SG/4
5/3 open centre - G1/4	MEK/CA/SG/4
5/3 pressure centre - G1/4	MEK/CP/SG/4

FLOW CHART - MEK G 1/8 5/2

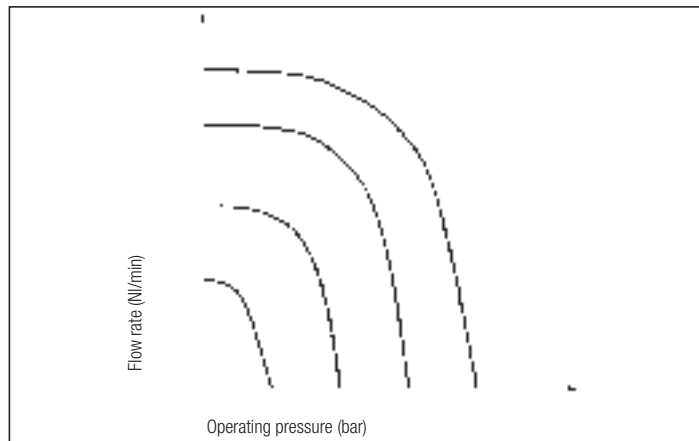

PILOTING CHART - MEK G 1/8

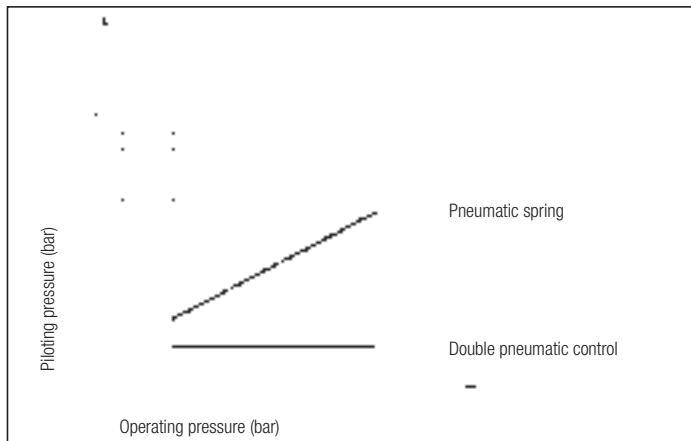

FLOW CHART - MEK G 1/4 5/2

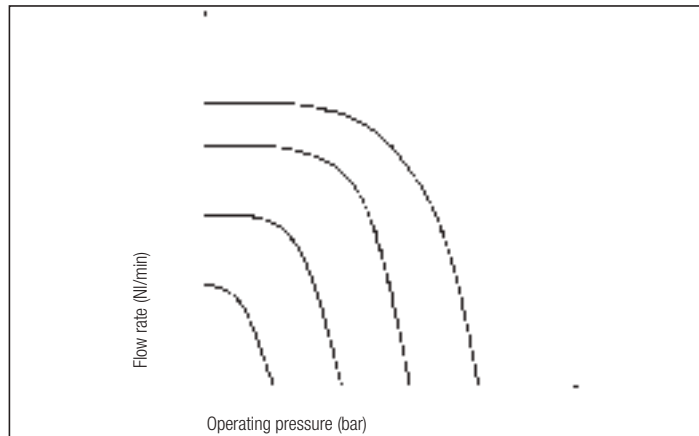

PILOTING CHART - MEK G 1/4

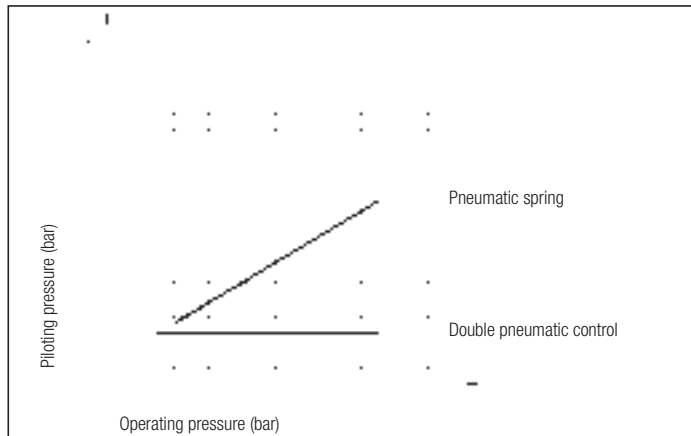

SOLENOID ACTUATED VALVES G 1/8

Symbol	Function	Controls		Response time at 6 bar (ms)		Flow rate at 6 bar $\Delta P = 1$ bar (l/min)	Weight (g)	TYPE*
		Pilot	Return	Energized	De-energized			
	5/2 monostable	Pneumatic	Pneumomechanical spring	5	10	530	110	MEKCA8 KR/ZQ
		Pneumatic	Pneumatic spring	7	5	530	110	MEKCA8 KR/TQ
	5/2 bistable	Pneumatic	Pneumatic	3	3	530	120	MEKCA8 KR/KR
	5/3 closed centre	Pneumatic	Mechanical spring	4	8	450	135	MEKCA8 SR/SR
	5/3 open centre	Pneumatic	Mechanical spring	4	8	450	135	MEKCA8 AR/AR
	5/3 pressure centre	Pneumatic	Mechanical spring	4	8	450	135	MEKCA8 PR/PR

*/EX Consistent with the ATEX directive II 2GD c T5 T100°C - 10°C ≤ Ta ≤ 60°C

ES.: MEKCA8 KR/ZQ/EX

MEKCA8 KR/ZQ

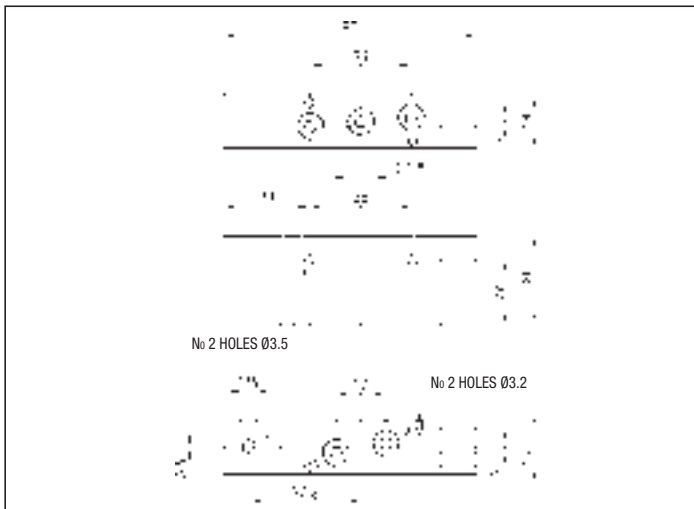

MEKCA8 KR/TQ

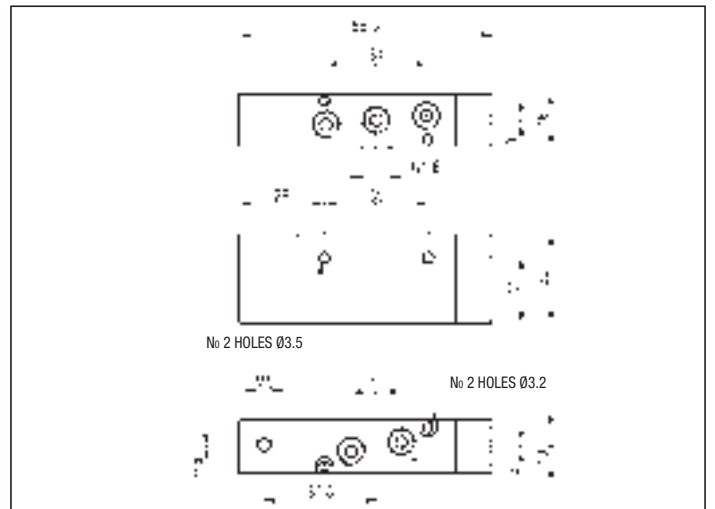

MEKCA8 KR/KR

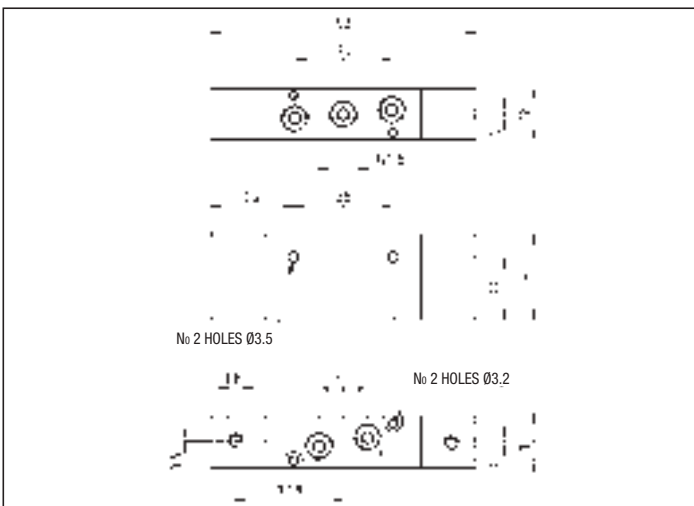

MEKCA8 SR/SR - MEKCA8 AR/AR - MEKCA8 PR/PR

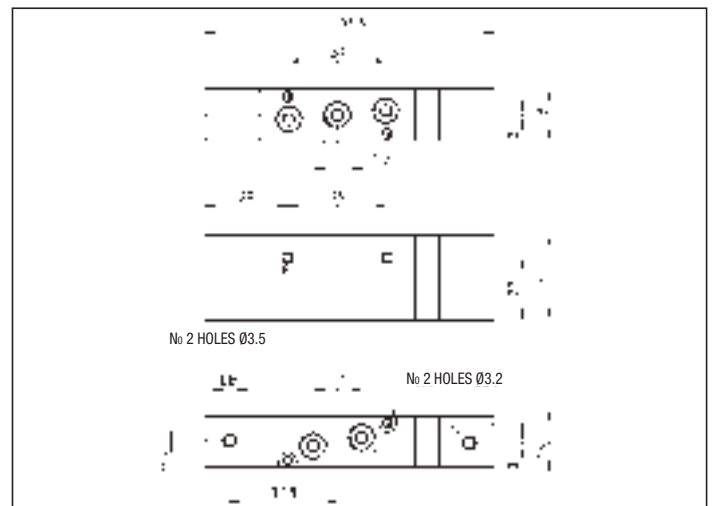

2

SOLENOID ACTUATED VALVES G 1/8

Symbol	Function	Controls		Response time at 6 bar (ms)		Flow rate at 6 bar $\Delta P = 1$ bar (l/min)	Weight (g)	TYPE*
		Pilot	Return	Energized	De-energized			
	5/2 monostable	Solenoid	Pneumomechanical spring	12	15	530	150	MEKCA8 KUC/ZQ
		Solenoid	Pneumatic spring	12	15			MEKCA8 KUC/TQ
		Solenoid pilot assisted	Pneumomechanical spring	10	20			MEKCA8 KUR/ZQ
	5/2 bistable	Solenoid	Solenoid	9	9	530	195	MEKCA8 KUC/KUC
		Solenoid pilot assisted	Solenoid pilot assisted					MEKCA8 KUR/KUR
	5/3 closed centre	Solenoid	Mechanical spring	10	25	450	210	MEKCA8 SUC/SUC
		Solenoid pilot assisted	Mechanical spring					MEKCA8 SUR/SUR
	5/3 open centre	Solenoid	Mechanical spring	10	25	450	210	MEKCA8 AUC/AUC
		Solenoid pilot assisted	Mechanical spring					MEKCA8 AUR/AUR
	5/3 pressure centre	Solenoid	Mechanical spring	10	25	450	210	MEKCA8 PUC/PUC
		Solenoid pilot assisted	Mechanical spring					MEKCA8 PUR/PUR

* SPECIFY THE VOLTAGE IN THE ORDER - E.G.: **MEKCA8 KUC/ZQ 02400**

02400 = 24 V DC

11050-60 = 110 V AC

/EX Consistent with the ATEX directive



II 3G c Ex nA IIC T5 Gc -5°C ≤ T_a ≤ 50°C
II 3D c Ex tc IIIC T100°C IP65 Dc

02450-60 = 24 V AC

22050-60 = 220 V AC

E.G.: **MEKCA8 KUC/ZQ 02400/EX**

MEKCA8 KUC/ZQ

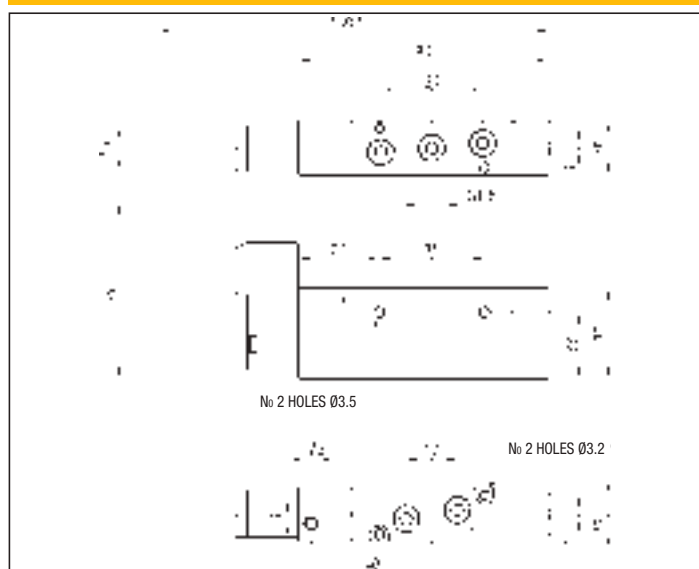

MEKCA8 KUC/TQ

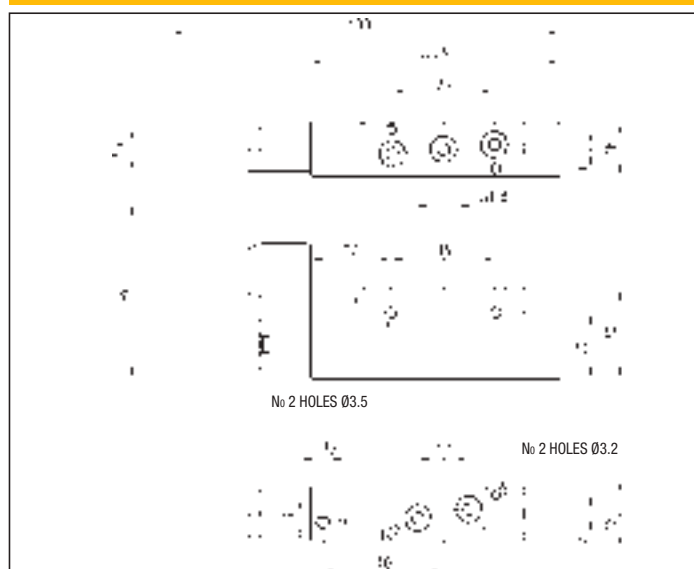

MEKCA8 KUR/ZQ

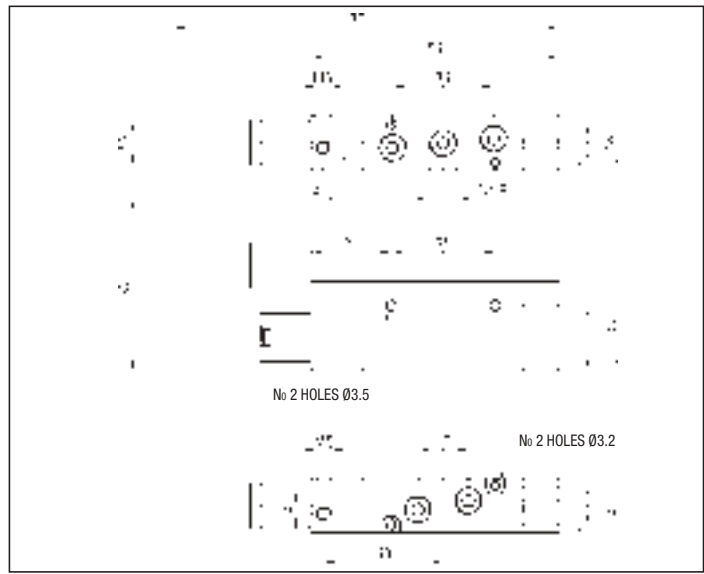

MEKCA8 KUC/KUC

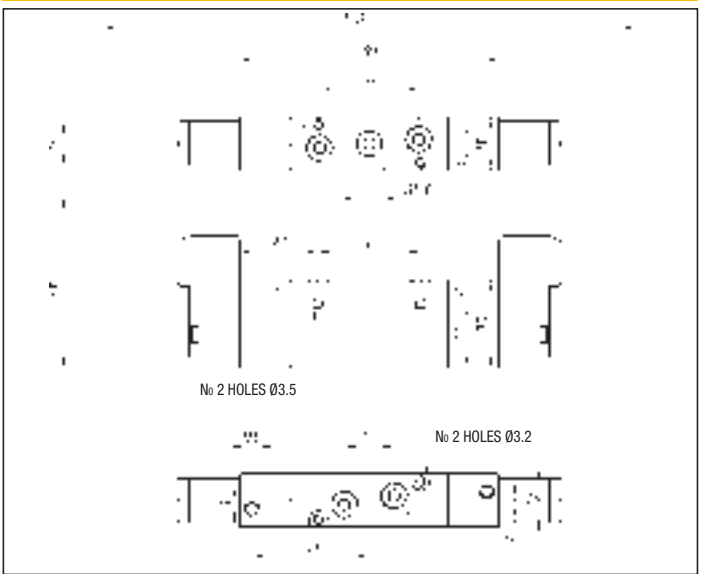

MEKCA8 KUR/KUR

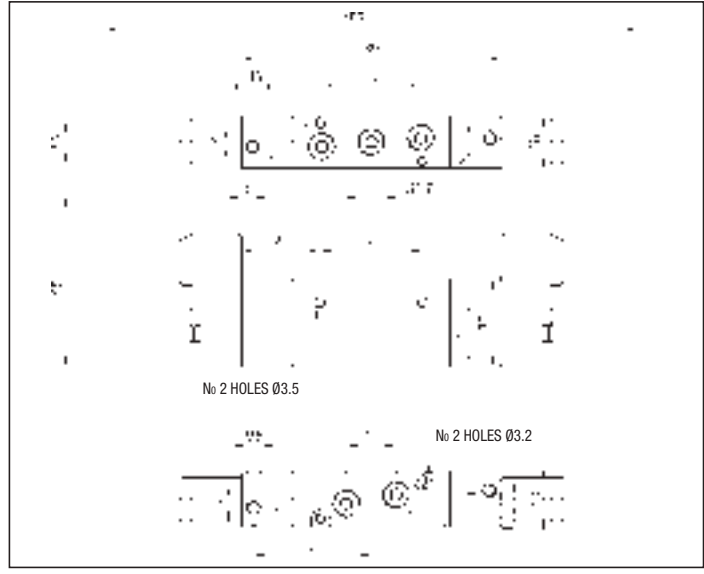

MEKCA8 SUC/SUC - MEKCA8 AUC/AUC - MEKCA8 PUC/PUC

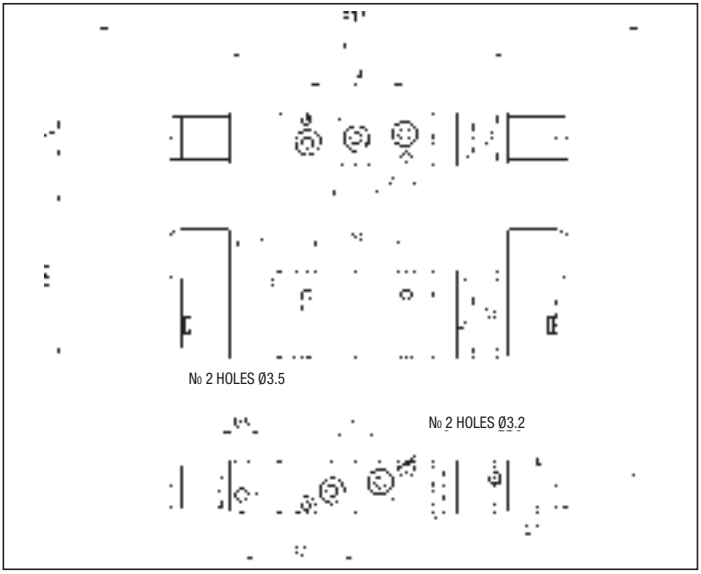

MEKCA8 SUR/SUR - MEKCA8 AUR/AUR - MEKCA8 PUR/PUR

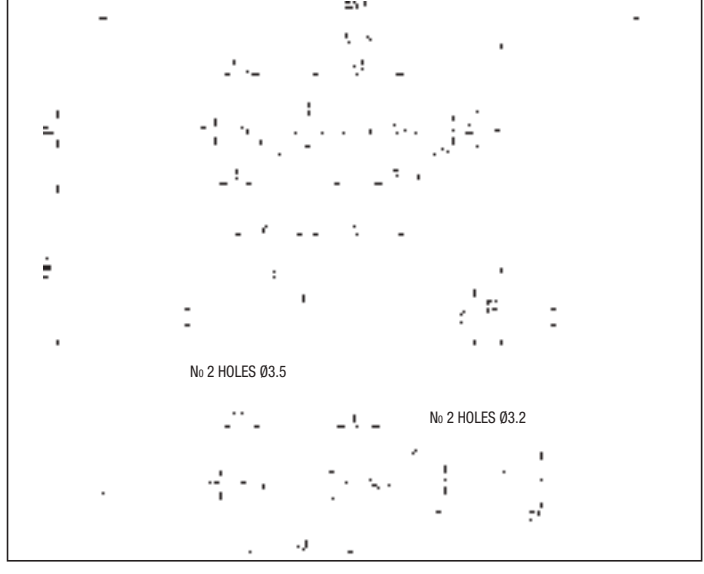

2

BASE FOR MANIFOLD MOUNTING OF VALVES G 1/8 - KB/MEK8 - Fit for mounting onto DIN 46277/3 rail

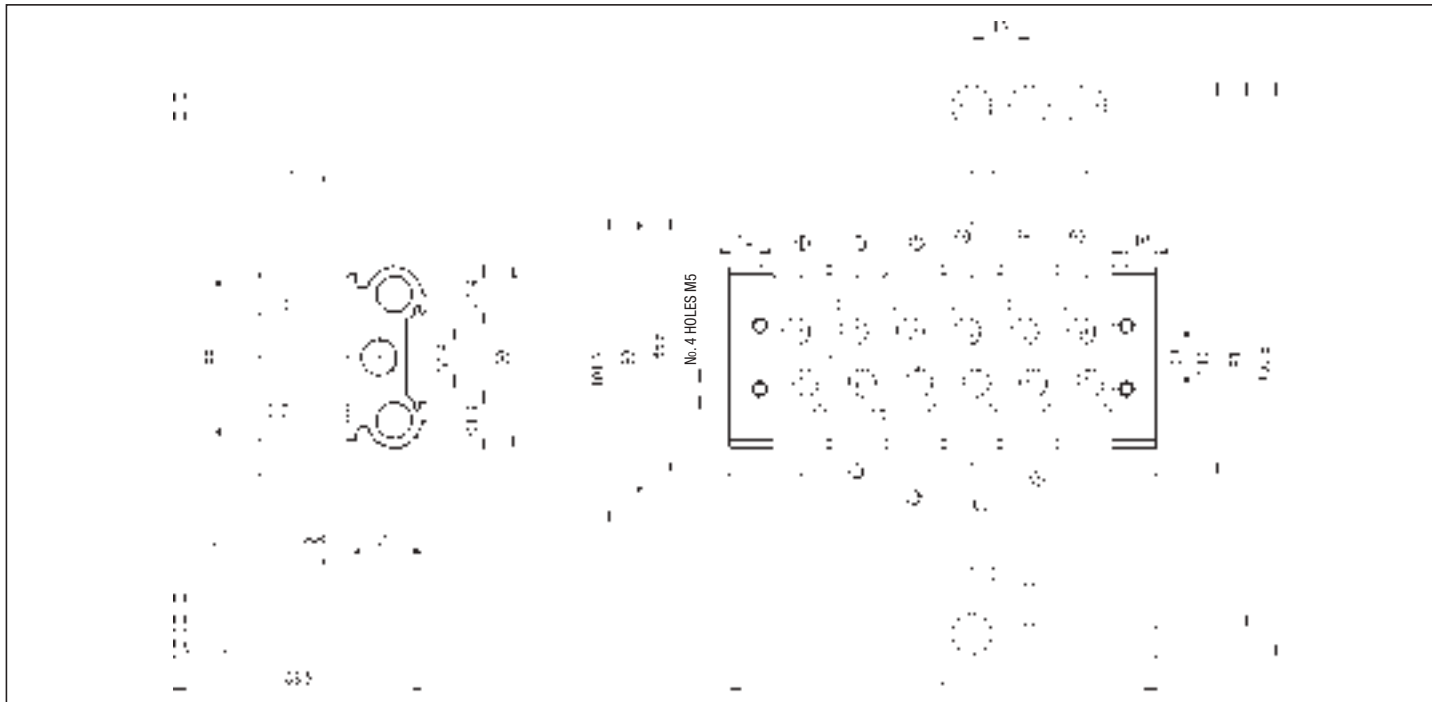

No of stations	2	3	4	5	6	8	10	12	14	16	18	20
L	66	85	104	123	142	180	218	256	294	332	370	408
Weight (g)	175	220	265	310	355	445	535	625	715	805	895	985
TYPE*	KB/MEK8/2	KB/MEK8/3	KB/MEK8/4	KB/MEK8/5	KB/MEK8/6	KB/MEK8/8	KB/MEK8/10	KB/MEK8/12	KB/MEK8/14	KB/MEK8/16	KB/MEK8/18	KB/MEK8/20

BLANKING PLATE - KIT/PC/MEK8



PLATE WITH PUSH-IN FITTING FOR PIPE Ø 6 mm - KIT/IR/MEK8

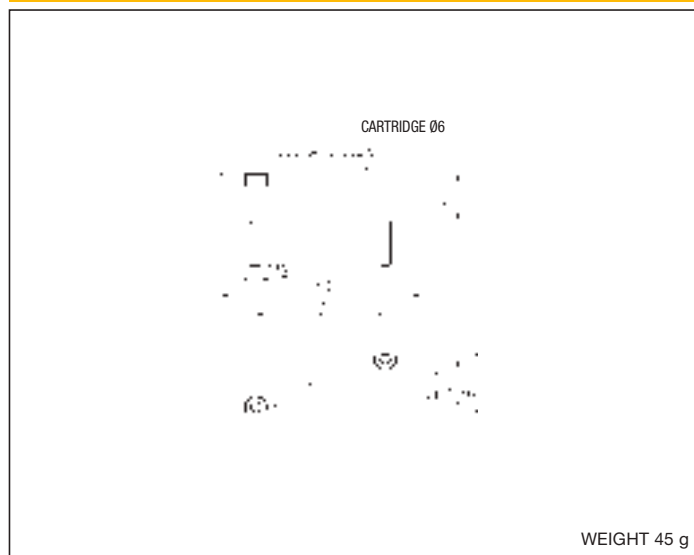

PILOT ACTUATED VALVES G 1/4

Symbol	Function	Controls		Response time at 6 bar (ms)		Flow rate at 6 bar $\Delta P = 1$ bar (l/min)	Weight (g)	TYPE*
		Pilot	Return	Energized	De-energized			
	5/2 monostable	Pneumatic	Pneumomechanical spring	7	3	900	190	MEKCA4 KR/ZQ
	5/2 bistable	Pneumatic	Pneumatic	5	5	900	215	MEKCA4 KR/KR
	5/3 closed centre	Pneumatic	Mechanical spring	5	15	600	240	MEKCA4 SR/SR
	5/3 open centre	Pneumatic	Mechanical spring	5	15	600	240	MEKCA4 AR/AR
	5/3 pressure centre	Pneumatic	Mechanical spring	5	15	600	240	MEKCA4 PR/PR

*/EX Consistent with the ATEX directive II 2GD c T5 T100°C -10°C ≤ Ta ≤ 60°C E.G.: MEKCA4 KR/ZQ/EX

MEKCA4 KR/ZQ

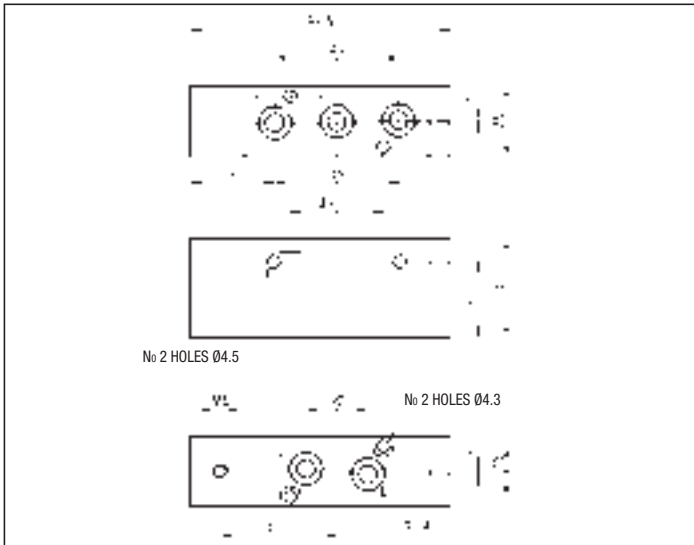

MEKCA4 KR/KR

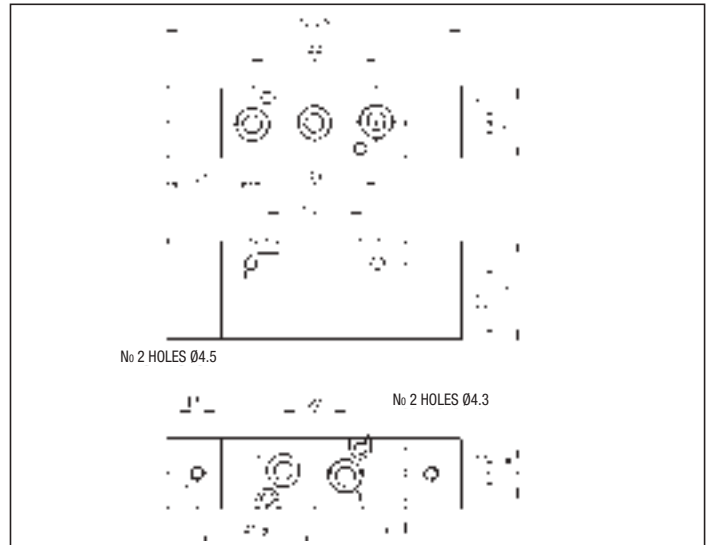

MEKCA4 SR/SR - MEKCA4 AR/AR - MEKCA4 PR/PR

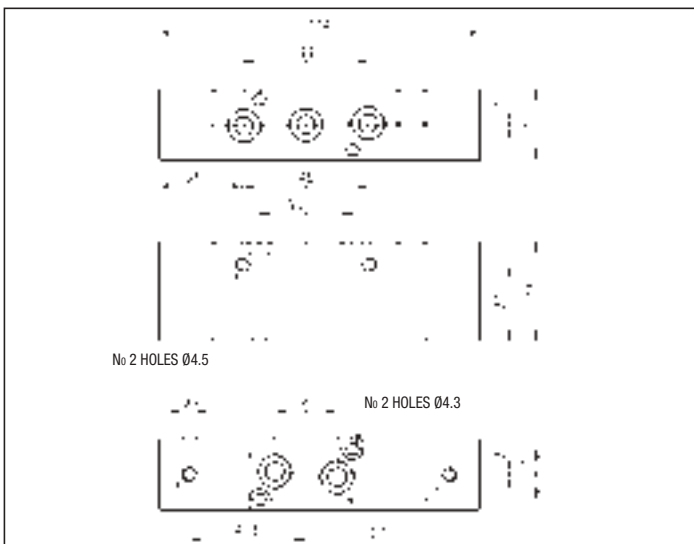

2

SOLENOID ACTUATED VALVES WITH COIL SIZE 15 mm G 1/4

Symbol	Function	Controls		Response time at 6 bar (ms)		Flow rate at 6 bar $\Delta P = 1$ bar (l/min)	Weight (g)	TYPE*
		Pilot	Return	Energized	De-energized			
	5/2 monostable	Solenoid	Pneumomechanical spring	15	20	900	225	MEKCA4 KUC/ZQ
		Solenoid pilot assisted	Pneumomechanical spring					MEKCA4 KUR/ZQ
	5/2 bistable	Solenoid	Solenoid	10	10	900	290	MEKCA4 KUC/KUC
		Solenoid pilot assisted	Solenoid pilot assisted					MEKCA4 KUR/KUR
	5/3 closed centre	Solenoid	Mechanical spring	15	30	600	315	MEKCA4 SUC/SUC
		Solenoid pilot assisted	Mechanical spring					MEKCA4 SUR/SUR
	5/3 open centre	Solenoid	Mechanical spring	12	30	600	315	MEKCA4 AUC/AUC
		Solenoid pilot assisted	Mechanical spring					MEKCA4 AUR/AUR
	5/3 pressure centre	Solenoid	Mechanical spring	10	30	600	315	MEKCA4 PUC/PUC
		Solenoid pilot assisted	Mechanical spring					MEKCA4 PUR/PUR

* SPECIFY THE VOLTAGE IN THE ORDER - E.G.: **MEKCA4 KUC/ZQ 02450-60**

02400 = 24 V DC

11050-60 = 110 V AC

02450-60 = 24 V AC

22050-60 = 220 V AC

/EX Consistent with the ATEX directive II 3G c Ex nA IIC T5 Gc -5°C ≤ Ta ≤ 50°C
II 3D c Ex tc IIIC T100°C IP65 Dc

E.G.: **MEKCA4 KUC/ZQ 02400/EX**

MEKCA4 KUC/ZQ

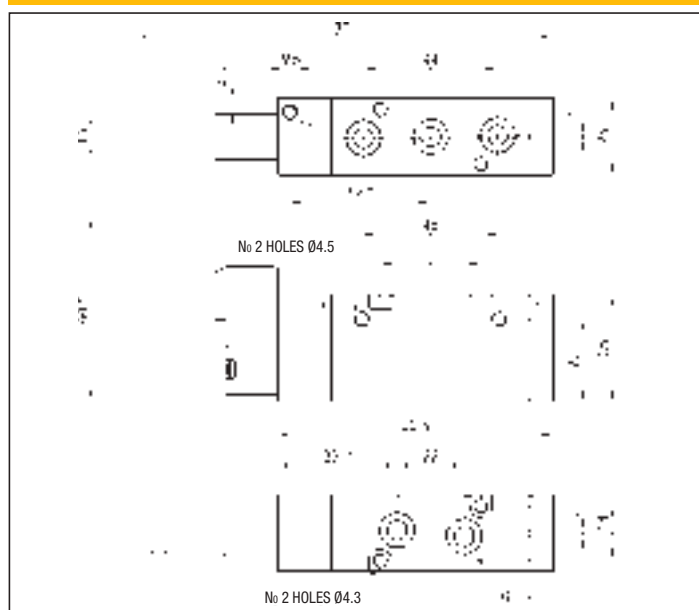

MEKCA4 KUR/ZQ

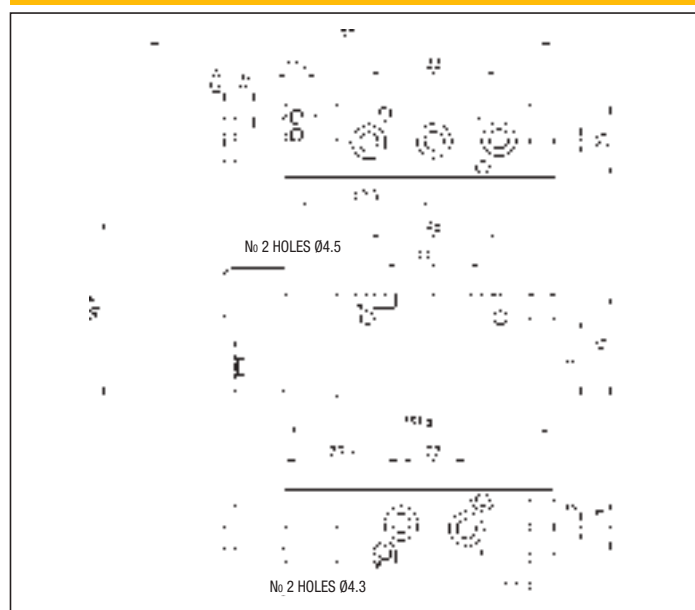

MEKCA4 KUC/KUC

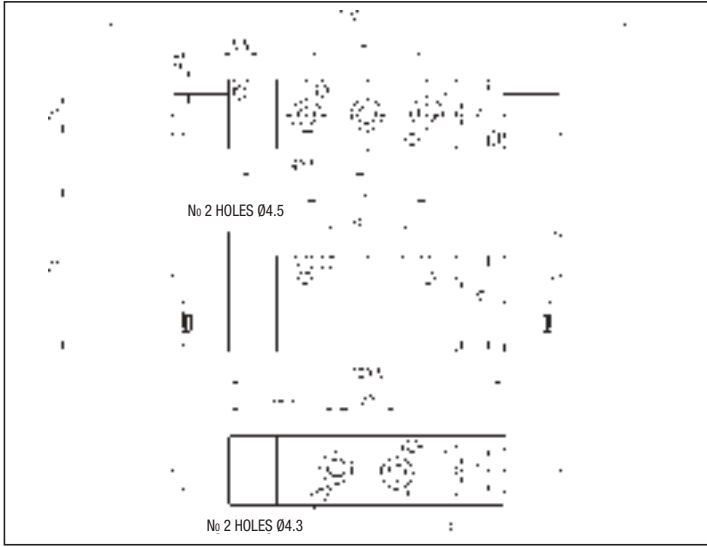

MEKCA4 KUR/KUR

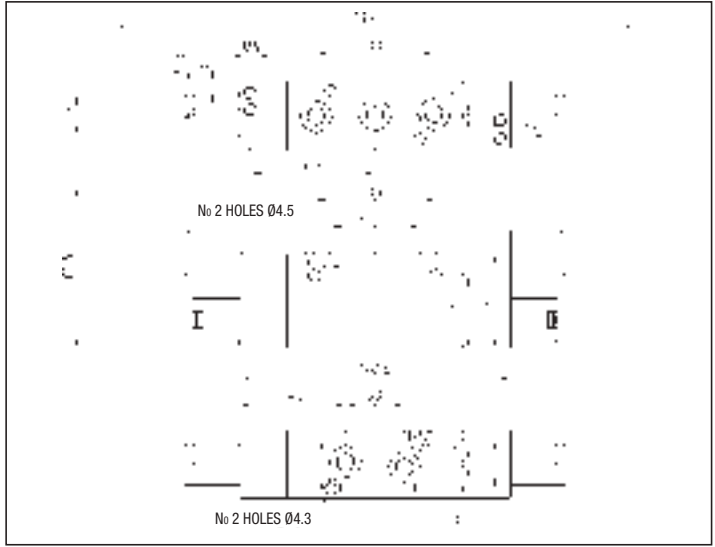

MEKCA4 SUC/SUC - MEKCA4 PUC/PUC - MEKCA4 AUC/AUC

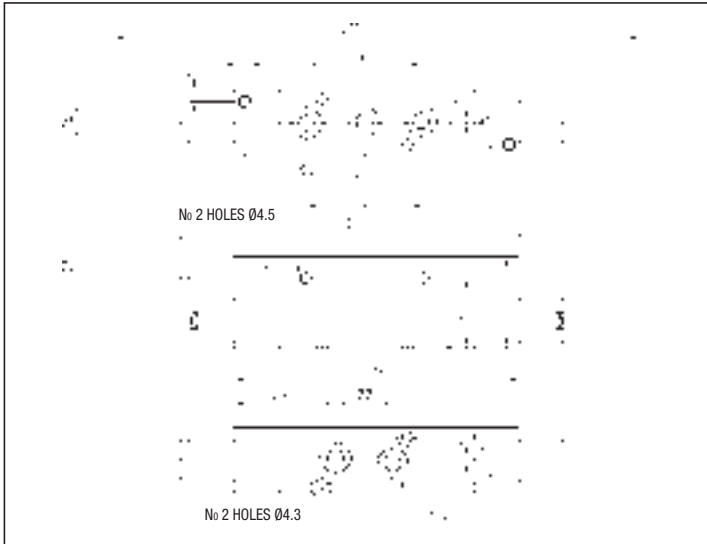

MEKCA4 SUR/SUR - MEKCA4 PUR/PUR - MEKCA4 AUR/AUR

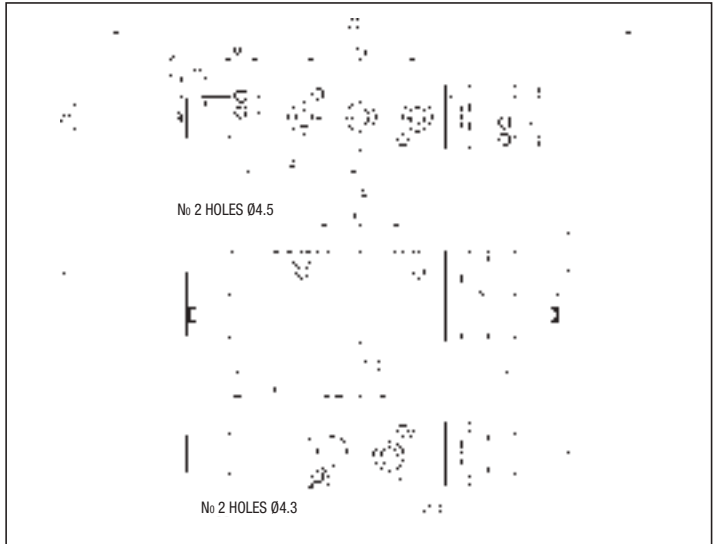

2

SOLENOID ACTUATED VALVES WITH SLEEVE Ø 9 mm G 1/4

Symbol	Function	Controls		Response time at 6 bar (ms)		Flow rate at 6 bar $\Delta P = 1$ bar (l/min)	Weight (g)	TYPE*
		Pilot	Return	Energized	De-energized			
	5/2 monostable	Solenoid	Pneumomechanical spring	22	24	900	210	MEKCA4 KUCG/ZQ
		Solenoid pilot assisted	Pneumomechanical spring					MEKCA4 KURG/ZQ
	5/2 bistable	Solenoid	Solenoid	16	16	900	260	MEKCA4 KUCG/KUCG
		Solenoid pilot assisted	Solenoid pilot assisted					MEKCA4 KURG/KURG
	5/3 closed centre	Solenoid	Mechanical spring	21	30	600	280	MEKCA4 SUCG/SUCG
		Solenoid pilot assisted	Mechanical spring					MEKCA4 SURG/SURG
	5/3 open centre	Solenoid	Mechanical spring	18	30	600	280	MEKCA4 AUCG/AUCG
		Solenoid pilot assisted	Mechanical spring					MEKCA4 AURG/AURG
	5/3 pressure centre	Solenoid	Mechanical spring	15	30	600	280	MEKCA4 PUCG/PUCG
		Solenoid pilot assisted	Mechanical spring					MEKCA4 PURG/PURG

* THE TYPES OF THE SOLENOID VALVES DO NOT INCLUDE COILS

/EX Consistent with the ATEX directive II 2GD c T5 T100°C -10°C ≤ Ta ≤ 60°C

E.G.: MEKCA4 KUCG/ZQ/EX

MEKCA4 KUCG/ZQ

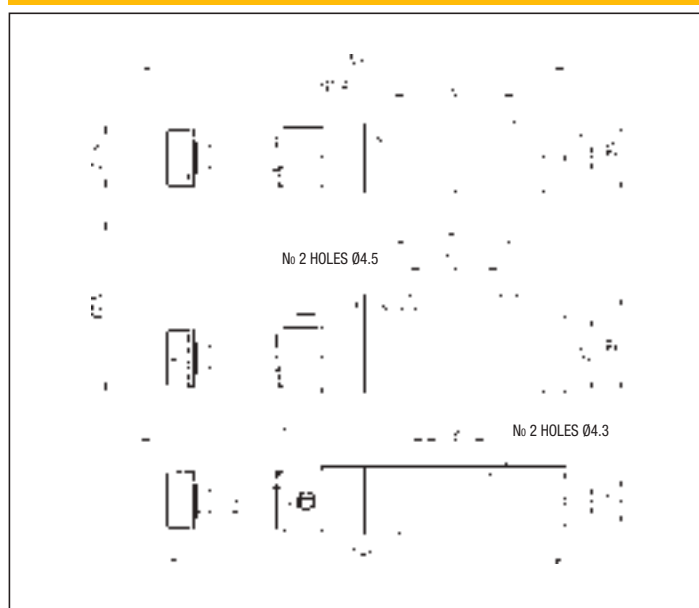

MEKCA4 KURG/ZQ

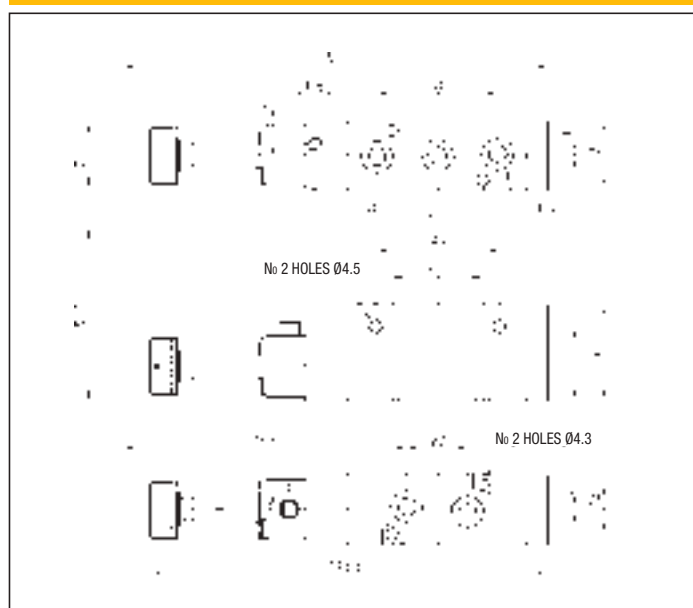

MEKCA4 KUCG/KUCG

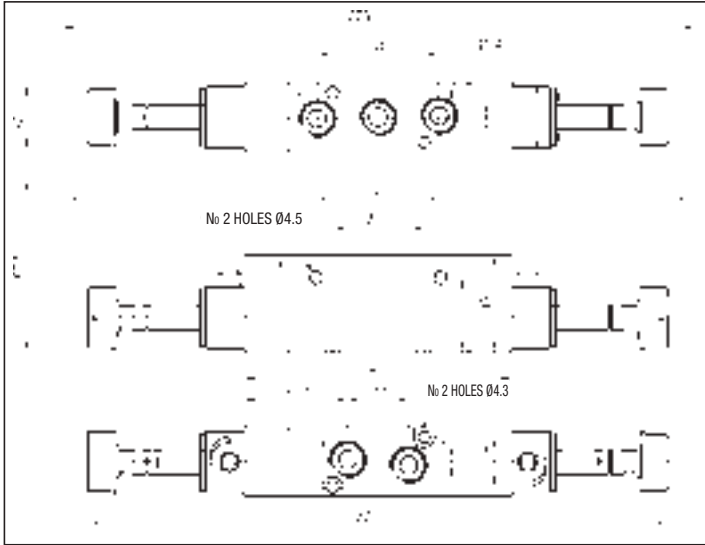

MEKCA4 KURG/KURG

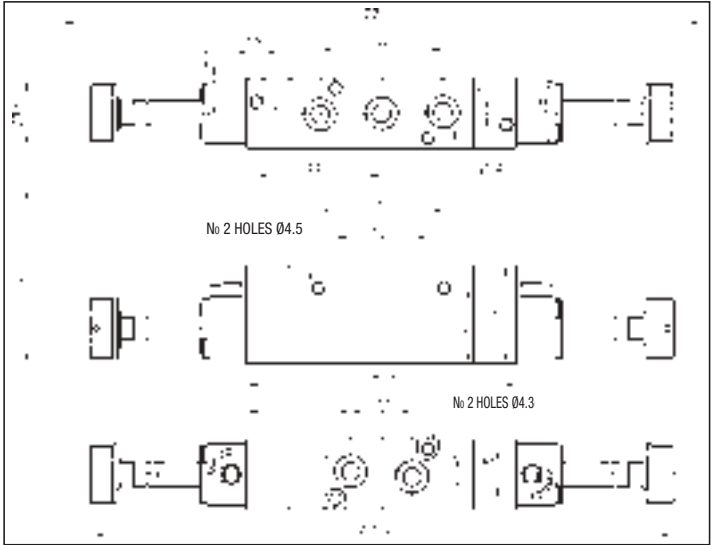

MEKCA4 SUCG/SUCG - MEKCA4 PUCG/PUCG - MEKCA4 AUCG/AUCG

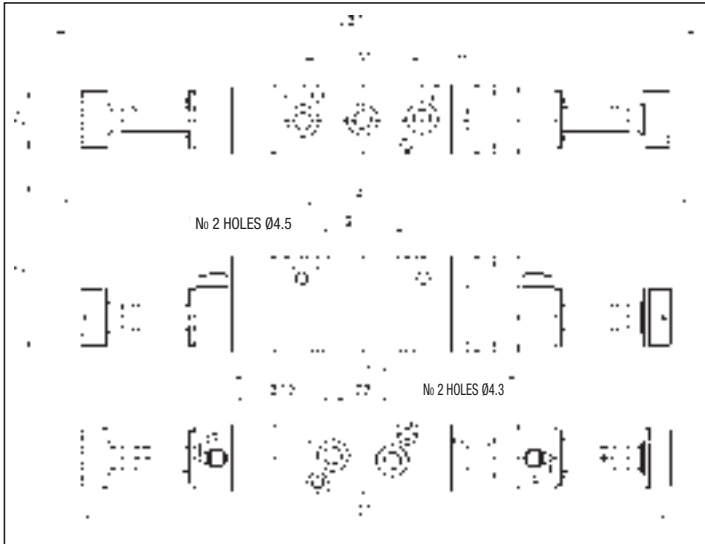

MEKCA4 SURG/SURG - MEKCA4 PURG/PURG - MEKCA4 AURG/AURG

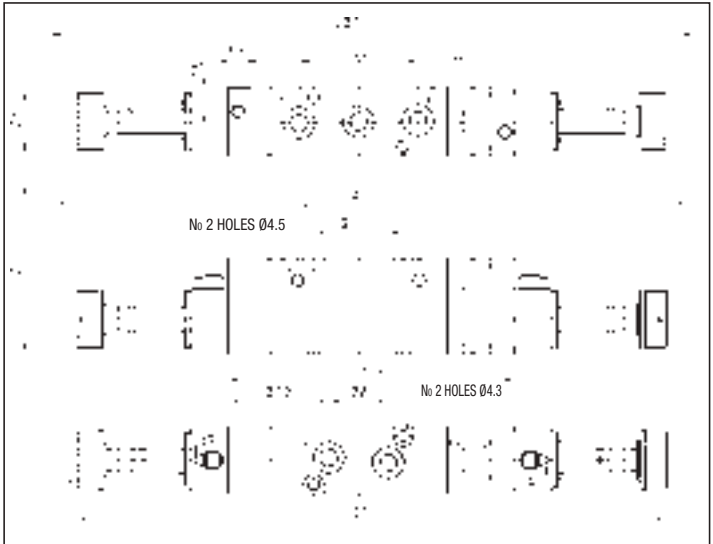

BASE FOR MANIFOLD MOUNTING OF VALVES G 1/4 - KB/MEK4 - Fit for mounting onto DIN 46277/3 rail

2

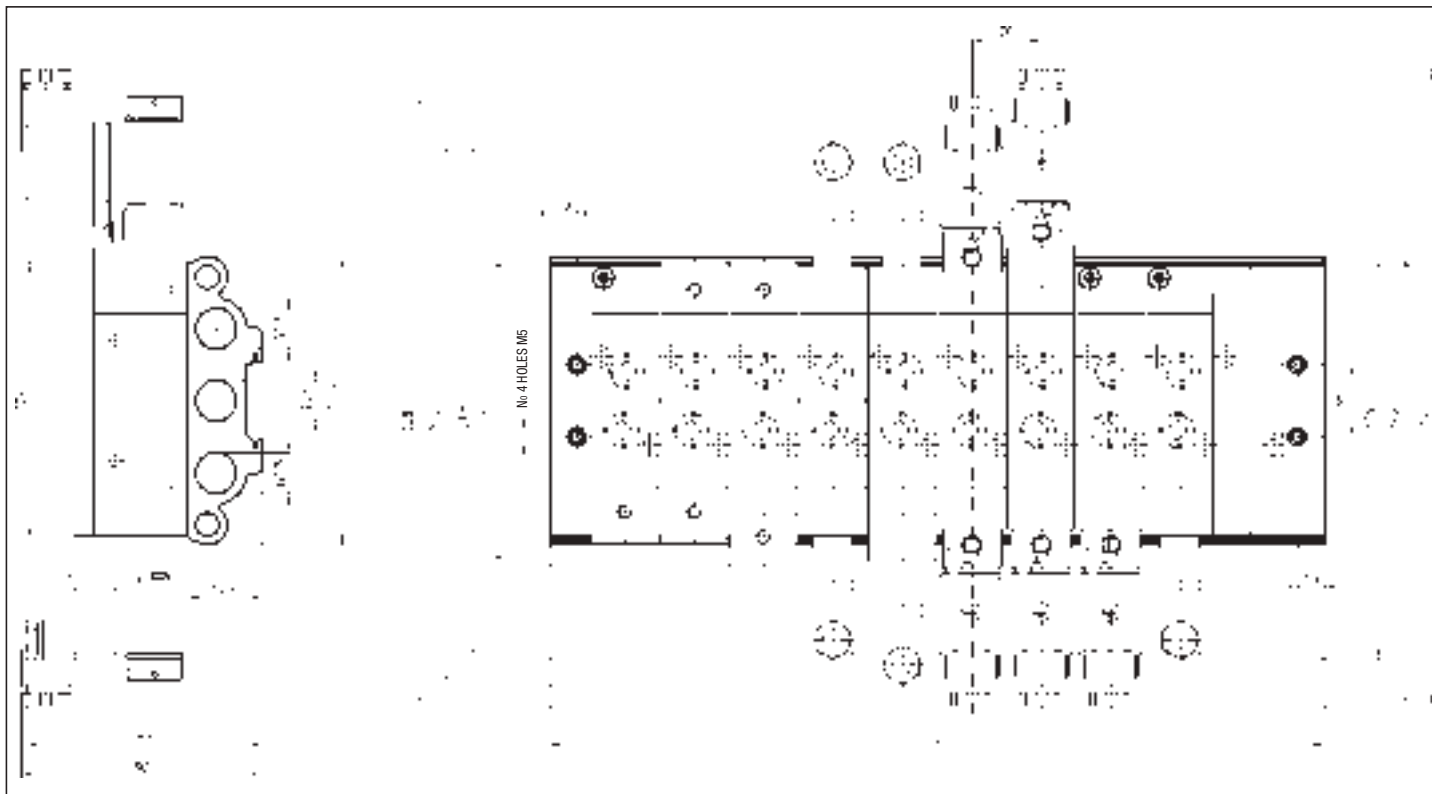

No of stations	2	3	4	5	6	8	10	12	14	16	18	20
L	82	108	134	160	186	238	290	342	394	446	498	550
Weight (g)	370	475	580	685	790	1000	1210	1220	1630	1840	2050	2260
TYPE*	KB/MEK4/2	KB/MEK4/3	KB/MEK4/4	KB/MEK4/5	KB/MEK4/6	KB/MEK4/8	KB/MEK4/10	KB/MEK4/12	KB/MEK4/14	KB/MEK4/16	KB/MEK4/18	KB/MEK4/20

*BASES ARE SUPPLIED COMPLETE WITH SCREWS AND SEALS

BLANKING PLATE - KIT/PC/MEK4

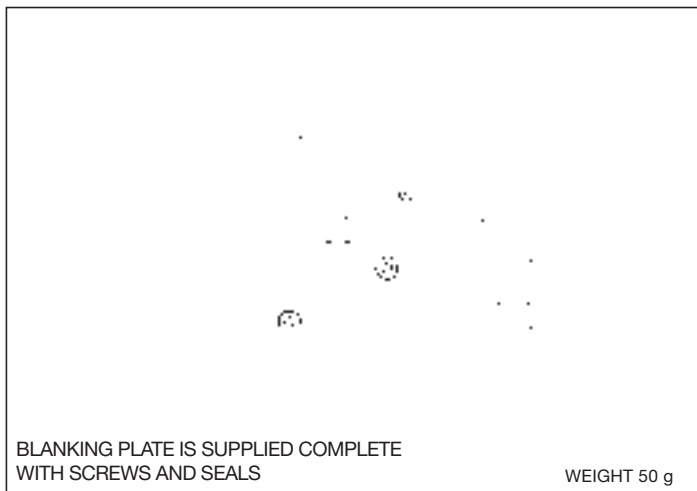
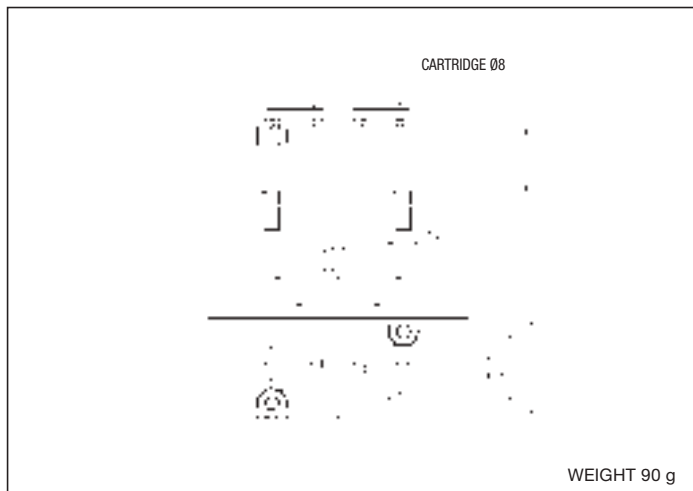

PLATE WITH PUSH-IN FITTING FOR PIPE Ø 8 mm - KIT/IR/MEK4



Spool valves pilot and solenoid actuated G 1/8 - G 1/4 - G 1/2

serie **EK**

DESCRIPTION

Valves series "EK" are produced in the 3/2, 5/2 and 5/3 pneumatic functions. The piloting solenoid valve can be assembled perpendicular respect the body valve, thanks to a suitable bracket. The kind of construction is based on a balanced spool with static seal, being the seals supported by distance rings integral to the body. This series of valves, in the size G 1/8 and G 1/4, is prearranged for both manifold mounting (conveyed inlet and exhausts), or supply rail mounting (conveyed inlet), by means of rear notch screws. The versions size G 1/4 - 5 port are available even with "Namur" port pattern or with high flow rate (see series EK30 on page 2.70). Upon request, they can be supplied in compliance with ATEX directive, category 2GD.

TECHNICAL DATA

Operating pressure	Monostable: 2,5 ÷ 10 bar Bistable: 2 ÷ 10 bar
Working temperature	0 ÷ +70 °C (-20 °C with dry air)
Fluid	Compressed air, filtered, continuous lubricated, unlubricated or dry lubricated
Port size	G 1/8 - G 1/4 - G 1/2
Pneumatic piloting port size	G 1/8
Nominal diameter	G 1/8 = 5 mm; G 1/4 = 7 mm; G 1/2 = 12 mm
Piloting solenoid valve	C/USCVP - see chapter direct acting solenoid valves on page 2.14
Coils	USB - see chapter coils on page 2.17 USBG - see chapter coils on page 2.17* USBG2 - see chapter coils on page 2.17*
Electric connectors	USR 102/N9 - see chapter connectors on page 2.18 ULR1B - see chapter connectors on page 2.18*

* Only for single valve
(coil and connector overcome the overall dimensions of the valves)

FLOW CHART - EK G 1/8 - 3/2 & 5/2

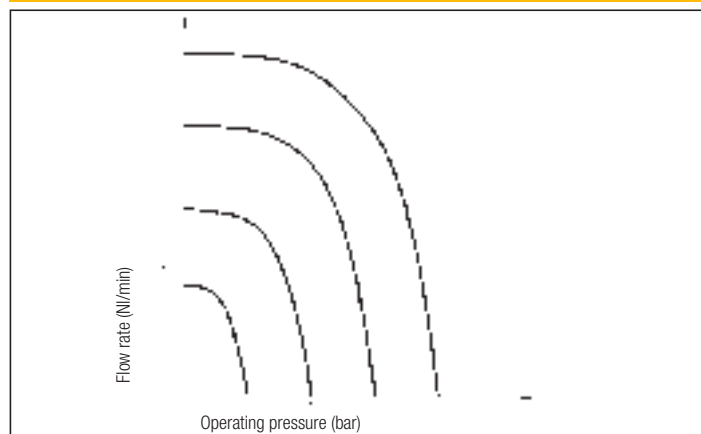

FLOW CHART - EK G 1/4 - 3/2 & 5/2

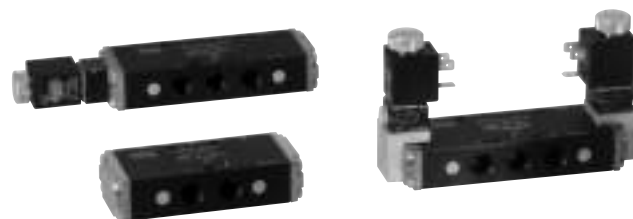
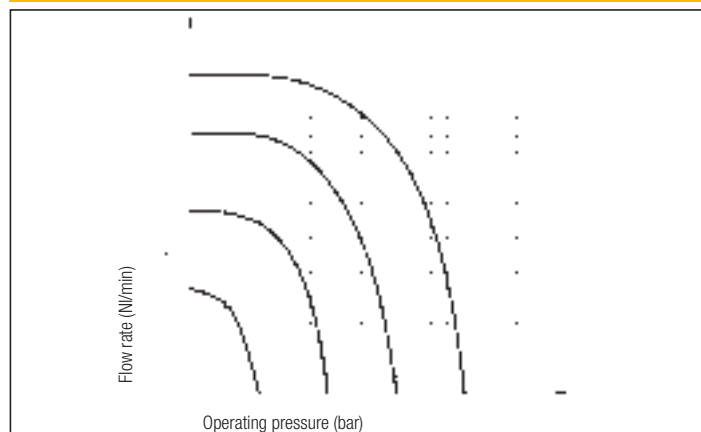

MATERIALS

Bottoms	Anodized aluminium alloy
Body	Anodized aluminium alloy
Distance rings	Acetal resin
Springs	Galvanized steel
Seals	NBR rubber
Spools	Anodized aluminium alloy
Piston	Anodized aluminium alloy

SPARE PARTS

SEALS KIT	
3/2 - G 1/8	EK/SG/8
3/2 - G 1/4	EK/SG/4
3/2 - G 1/2	EK/SG/2
5/2 - G 1/8	EKCA/SG/8
5/3 - G 1/8	EKCA/SG/8 - 5/3
5/2 - G 1/4	EKCA/SG/4
5/3 - G 1/4	EKCA/SG/4 - 5/3
5/2 - G 1/2	EKCA/SG/2
5/3 - G 1/2	EKCA/SG/2 - 5/3
5/2 - G 1/4 Namur	ENCA/SG/4
5/3 - G 1/4 Namur	ENCA/SG/4 - 5/3

PILOTING CHART - EK G 1/8

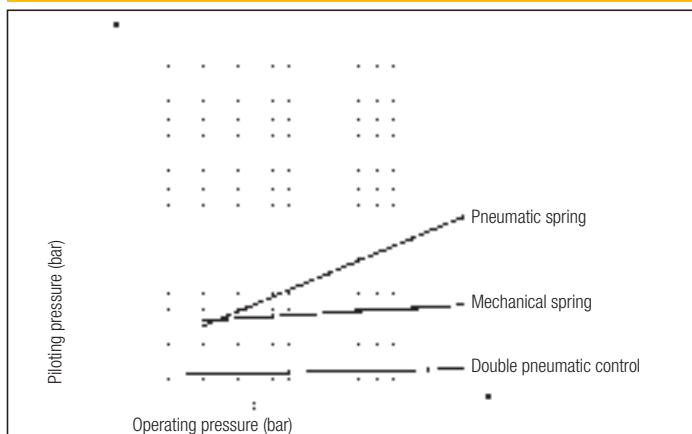

PILOTING CHART - EK G 1/4

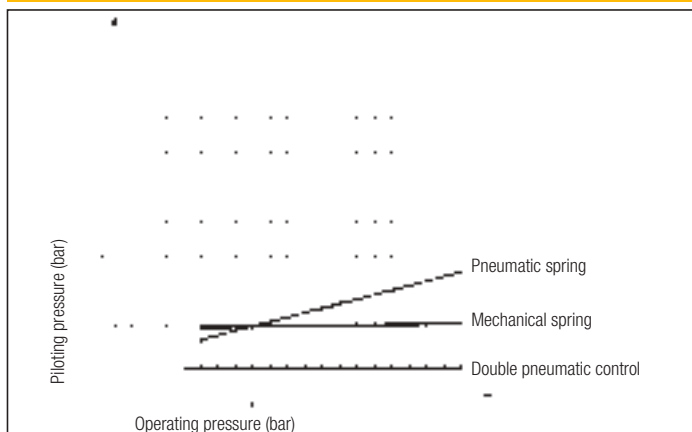

2

FLOW CHART - EK G 1/2 - 3/2 & 5/2

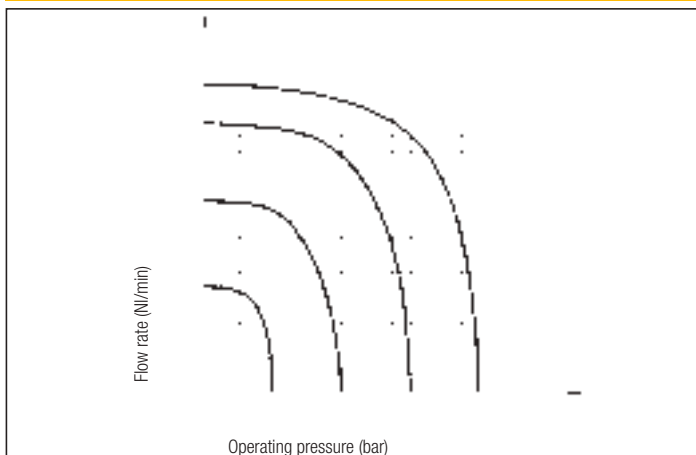

PILOTING CHART - EK G 1/2

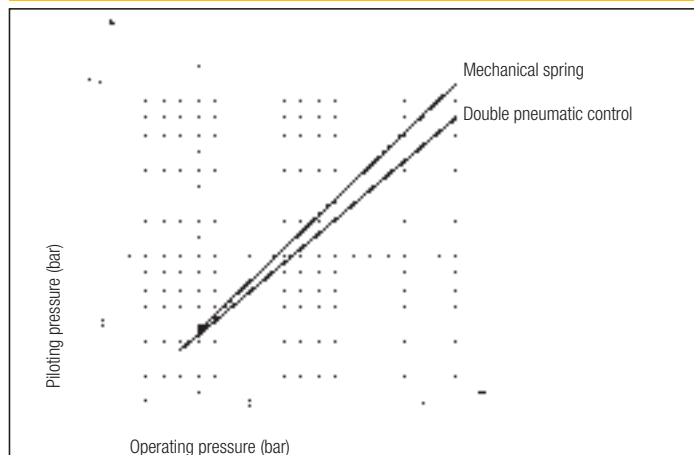

PILOT ACTUATED VALVES G 1/8 - 3 PORT

Symbol	Function	Controls		Response time at 6 bar (ms)		Flow rate at 6 bar $\Delta P = 1$ bar (NI/min)	Weight (g)	TYPE*
		Pilot	Return	Energized	De-energized			
	3/2 N.O. monostable	Pneumatic	Mechanical spring	18	10	550	220	EKA8 KR/ZR
		Pneumatic	Pneumatic spring	26	16			
	3/2 N.C. monostable	Pneumatic	Mechanical spring	14	8	550	220	EKC8 KR/ZR
		Pneumatic	Pneumatic spring	30	28			
	3/2 bistable	Pneumatic	Pneumatic	10	10	550	215	EK8 KR/KR
		Big pneumatic	Small pneumatic	10	15			

*/EX Consistent with the ATEX directive II 2GD c T5 T100°C -20°C ≤ T_a ≤ 60°C

E.G.: EKA8 KR/ZR/EX

3 PORT

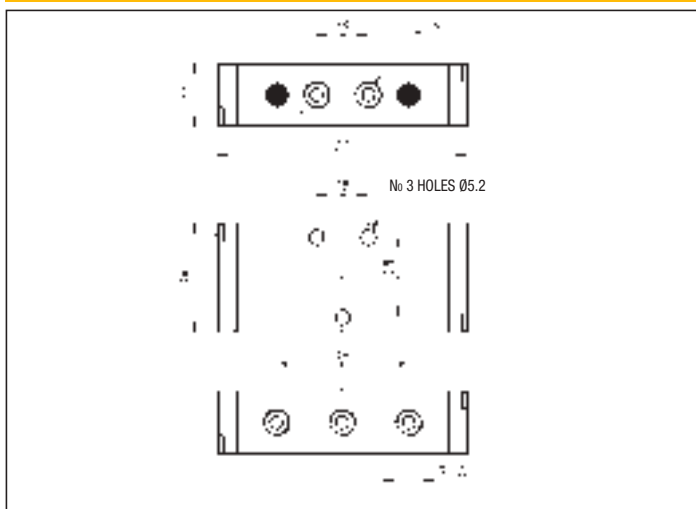

PILOT ACTUATED VALVES G 1/8 - 5 PORT

Symbol	Function	Controls		Response time at 6 bar (ms)		Flow rate at 6 bar $\Delta P = 1$ bar (l/min)	Weight (g)	TYPE*
		Pilot	Return	Energized	De-energized			
	5/2 monostable	Pneumatic	Mechanical spring	20	10	550	270	EKCA8 KR/ZR
		Pneumatic	Pneumatic spring	25	15	550	260	EKCA8 KR/TQ
	5/2 bistable	Pneumatic	Pneumatic	10	10	550	230	EKCA8 KR/KR
		Big pneumatic	Small pneumatic	12	15	550	230	EKCA8 KR/TR
	5/3 closed centre	Pneumatic	Mechanical spring	18	25	425	285	EKCA8 SR/SR
	5/3 open centre	Pneumatic	Mechanical spring	18	25	500	285	EKCA8 AR/AR
	5/3 pressure centre	Pneumatic	Mechanical spring	15	20	425	285	EKCA8 PR/PR

*EX Consistent with the ATEX directive II 2GD c T5 T100°C -20°C ≤ T_a ≤ 60°C E.G.: EKCA8 KR/ZR/EX

5 PORT

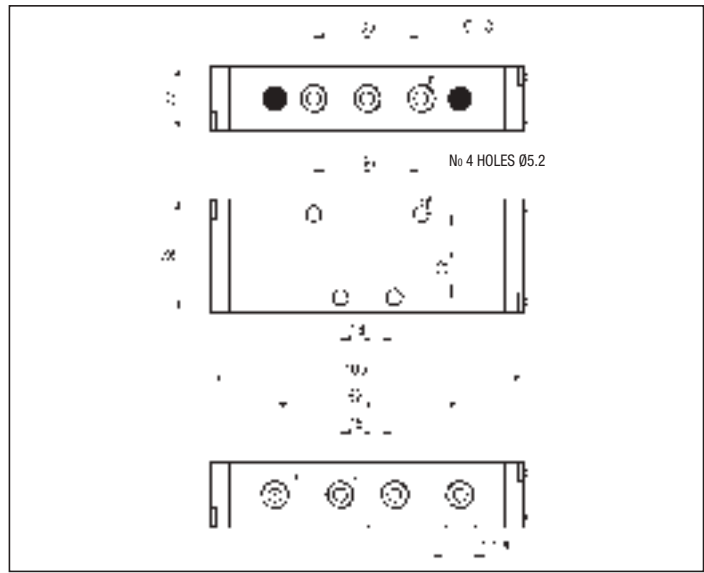

2

SOLENOID ACTUATED VALVES G 1/8 - 3 PORT

Symbol	Function	Controls		Response time at 6 bar (ms)		Flow rate at 6 bar $\Delta P = 1 \text{ bar (Nl/min)}$	Weight (g)	TYPE*
		Pilot	Return	Energized	De-energized			
	3/2 N.O. monostable	Solenoid	Mechanical spring	24	28	550	250	EKA8 KUC/ZR
		Solenoid	Pneumatic spring	18	27	550	245	EKA8 KUC/TQ
		Solenoid pilot assisted	Mechanical spring	24	28	550	250	EKA8 KUR/ZR
	3/2 N.C. monostable	Solenoid	Mechanical spring	32	31	550	250	EKC8 KUC/ZR
		Solenoid	Pneumatic spring	22	28	550	245	EKC8 KUC/TQ
		Solenoid pilot assisted	Mechanical spring	32	31	550	250	EKC8 KUR/ZR
	3/2 bistable	Solenoid	Solenoid	21	21	550	290	EK8 KUC/KUC
		Solenoid pilot assisted	Solenoid pilot assisted	21	21	550	290	EK8 KUR/KUR

P.S.: SUBSTITUTE THE LETTER "U" WITH THE LETTER "L" IN EACH SOLENOID CONTROL TYPE TO ORDER THE SOLENOID ACTUATED VALVES WITH SOLENOID AT 90° RESPECT THE BODY OF THE VALVE. E.G.: EKC8 KUC/TQ BECOMES EKC8 KLC/TQ (SEE ON PAGE 2.74 FOR THE MISSING DIMENSIONS)

*THE TYPES OF THE SOLENOID VALVES DO NOT INCLUDE COILS

/EX Consistent with the ATEX directive II 2GD c T5 T100°C -20°C ≤ T_a ≤ 60°C E.G.: EKA8 KUC/ZR/EX

3 PORT MONOSTABLE

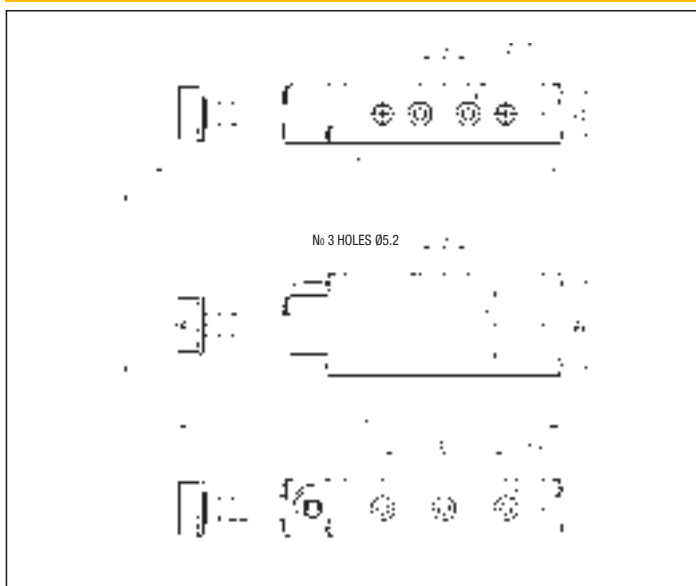

3 PORT BISTABLE

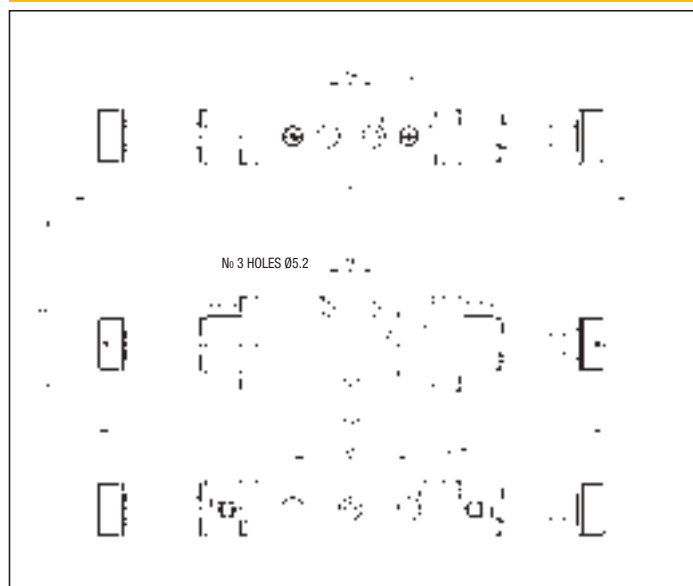

SOLENOID ACTUATED VALVES G 1/8 - 5 PORT

Symbol	Function	Controls		Response time at 6 bar (ms)		Flow rate at 6 bar $\Delta P = 1 \text{ bar (Nl/min)}$	Weight (g)	TYPE*
		Pilot	Return	Energized	De-energized			
	5/2 monostable	Solenoid	Mechanical spring	20	30	550	300	EKCA8 KUC/ZR
		Solenoid	Mechanical spring	27	39	550	300	EKCA8 KUC/TQ
		Solenoid pilot assisted	Mechanical spring	20	30	550	300	EKCA8 KUR/ZR
	5/2 bistable	Solenoid	Solenoid	18	18	550	325	EKCA8 KUC/KUC
		Solenoid pilot assisted	Solenoid pilot assisted	18	18	550	325	EKCA8 KUR/KUR
	5/3 closed centre	Solenoid	Mechanical spring	23	37	425	335	EKCA8 SUC/SUC
		Solenoid pilot assisted	Mechanical spring	23	37	425	335	EKCA8 SUR/SUR
	5/3 open centre	Solenoid	Mechanical spring	23	37	500	345	EKCA8 AUC/AUC
		Solenoid pilot assisted	Mechanical spring	23	37	500	345	EKCA8 AUR/AUR
	5/3 pressure centre	Solenoid	Mechanical spring	20	35	425	335	EKCA8 PUC/PUC
		Solenoid pilot assisted	Mechanical spring	20	25	425	335	EKCA8 PUR/PUR

P.S.: SUBSTITUTE THE LETTER "U" WITH THE LETTER "L" IN EACH SOLENOID CONTROL TYPE TO ORDER THE SOLENOID ACTUATED VALVES WITH SOLENOID AT 90° RESPECT THE BODY OF THE VALVE. E.G.: EKCA8 KUC/TQ BECOMES EKCA8 KLC/TQ (SEE ON PAGE 2.74 FOR THE MISSING DIMENSIONS)

*THE TYPES OF THE SOLENOID VALVES DO NOT INCLUDE COILS

/EX Consistent with the ATEX directive II 2GD c T5 T100°C -20°C ≤ Ta ≤ 60°C ES.: **EKCA8 KUC/ZR/EX**

5 PORT MONOSTABLE



5 PORT AND 3 POSITIONS BISTABLE

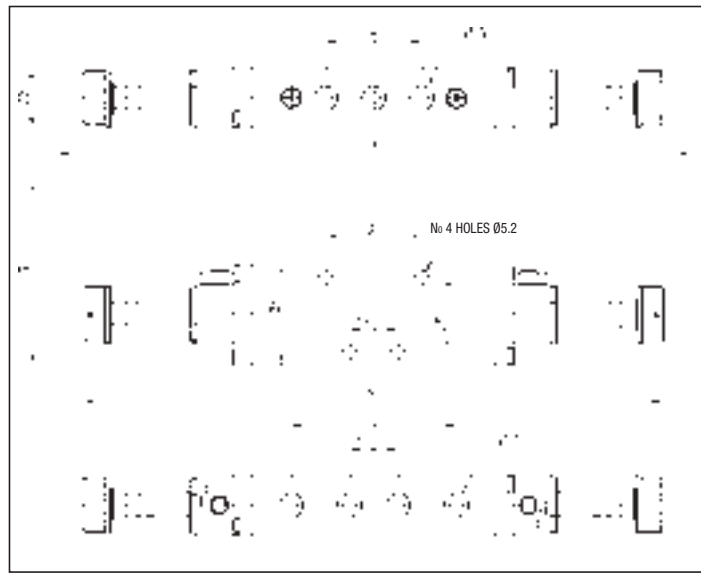

2

BASE FOR MANIFOLD MOUNTING OF VALVES G 1/8 - KB/EK8

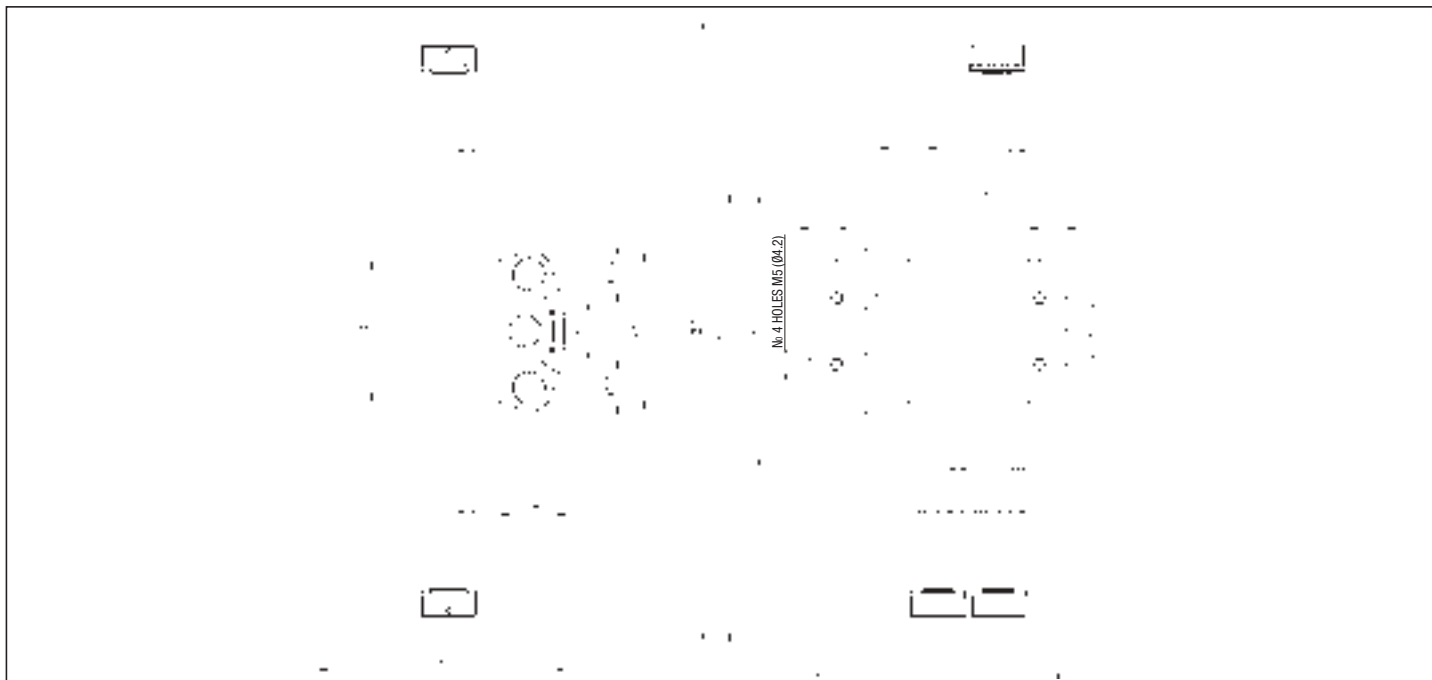

No of stations	2	3	4	5	6	8	10	12	14	16	18	20
L	74	97	120	143	166	212	258	304	350	396	442	488
Weight (g)	220	285	350	415	480	610	740	870	1000	1130	1260	1390
TYPE*	KB/EK8/2	KB/EK8/3	KB/EK8/4	KB/EK8/5	KB/EK8/6	KB/EK8/8	KB/EK8/10	KB/EK8/12	KB/EK8/14	KB/EK8/16	KB/EK8/18	KB/EK8/20

*BASES ARE SUPPLIED COMPLETE WITH HOLLOW SCREWS AND SEALS

SUPPLY RAIL FOR MANIFOLD MOUNTING OF VALVES G 1/8 - CEK8

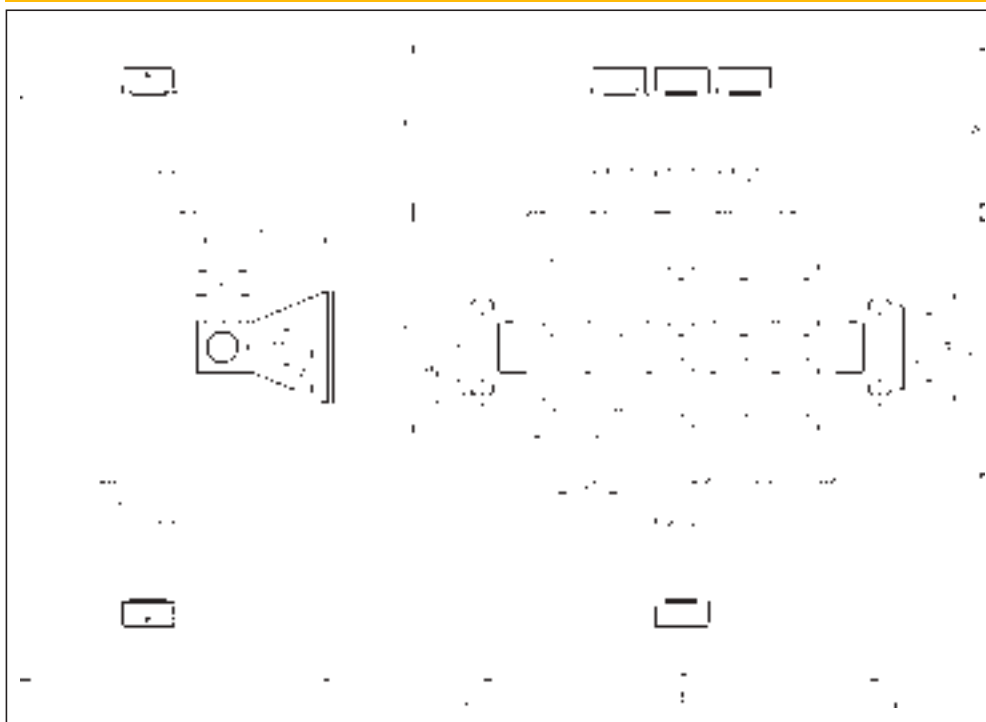

*SUPPLY RAILS ARE SUPPLIED COMPLETE WITH HOLLOW SCREWS, SEALS AND FIXING BRACKETS
P.S.: CAN BE MOUNTED ONLY SILENCERS SERIES **SS-01** (SEE THE HIDDEN SILENCERS ON PAGE 5.52)

BLANKING PLATE - KIT/PC/EK8

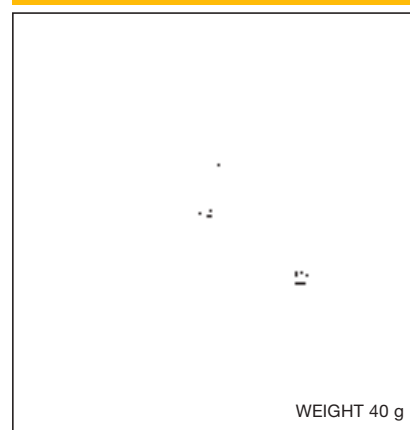

No of stations	2	3	5
LA	83	105	150
LB	101	123	168
Weight (g)	135	170	240
TYPE*	CEK8/2	CEK8/3	CEK8/5

PILOT ACTUATED VALVES G 1/4 - 3 PORT

Symbol	Function	Controls		Response time at 6 bar (ms)		Flow rate at 6 bar $\Delta P = 1 \text{ bar (l/min)}$	Weight (g)	TYPE*
		Pilot	Return	Energized	De-energized			
	3/2 N.O. monostable	Pneumatic	Mechanical spring	21	14	950	335	EKA4 KR/ZR
		Pneumatic	Pneumatic spring	28	10	950	325	EKA4 KR/TQ
	3/2 N.C. monostable	Pneumatic	Mechanical spring	21	14	950	335	EKC4 KR/ZR
		Pneumatic	Pneumatic spring	25	11	950	325	EKC4 KR/TQ
	3/2 bistable	Pneumatic	Pneumatic	11	11	950	330	EK4 KR/KR
		Pneumatic	Pneumatic differential	10	18	950	330	EK4 KR/TR

*EX Consistent with the ATEX directive II 2GD c T5 T100°C -20°C ≤ T_{as} ≤ 60°C E.G.: EKA4 KR/ZR/EX

3 PORT

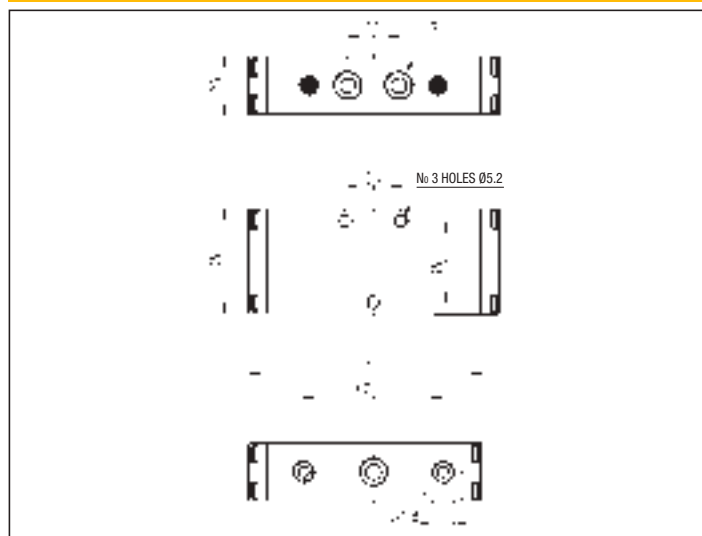

2

PILOT ACTUATED VALVES G 1/4 - 5 PORT

Symbol	Function	Controls		Response time at 6 bar (ms)		Flow rate at 6 bar $\Delta P = 1 \text{ bar (Nl/min)}$	Weight (g)	TYPE*
		Pilot	Return	Energized	De-energized			
	5/2 monostable	Pneumatic	Mechanical spring	18	14	900	385	EKCA4 KR/ZR
		Pneumatic	Pneumatic spring	25	11	900	370	EKCA4 KR/TQ
	5/2 bistable	Pneumatic	Pneumatic	11	11	900	370	EKCA4 KR/KR
		Pneumatic	Small pneumatic	10	20	900	370	EKCA4 KR/TR
	5/3 closed centre	Pneumatic	Mechanical spring	20	14	510	420	EKCA4 SR/SR
	5/3 open centre	Pneumatic	Mechanical spring	20	14	850	415	EKCA4 AR/AR
	5/3 pressure centre	Pneumatic	Mechanical spring	20	14	690	415	EKCA4 PR/PR

*/EX Consistent with the ATEX directive II 2GD c T5 T100°C -20°C ≤ T_a ≤ 60°C E.G.: EKCA4 KR/ZR/EX

5 PORT

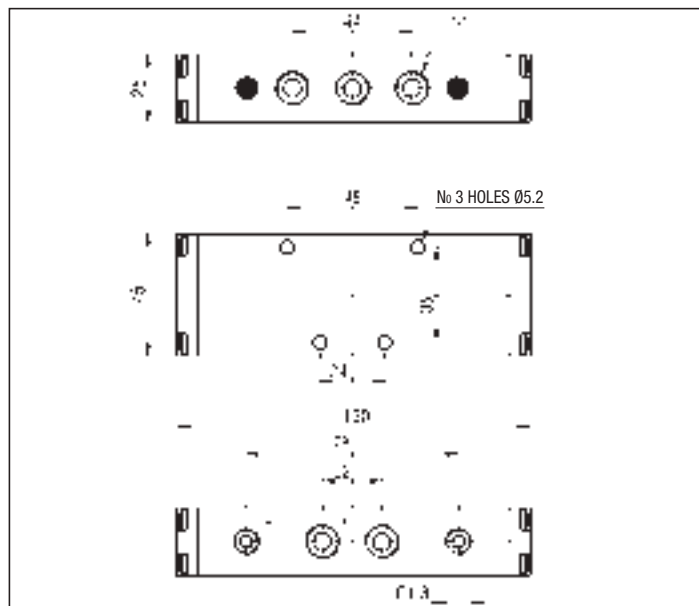

PILOT ACTUATED VALVES "NAMUR" PORT PATTERN G 1/4 - 5 PORT

Symbol	Function	Controls		Response time at 6 bar (ms)		Flow rate at 6 bar $\Delta P = 1 \text{ bar (Nl/min)}$	Weight (g)	TYPE*
		Pilot	Return	Energized	De-energized			
	5/2 monostable	Pneumatic	Mechanical spring	18	14	900	390	ENCA4 KR/ZR
		Pneumatic	Pneumatic spring	25	11	900	375	ENCA4 KR/TQ
	5/2 bistable	Pneumatic	Pneumatic	11	11	900	375	ENCA4 KR/KR
		Big pneumatic	Small pneumatic	10	20	900	375	ENCA4 KR/TR
	5/3 closed centre	Pneumatic	Mechanical spring	20	14	510	425	ENCA4 SR/SR
	5/3 open centre	Pneumatic	Mechanical spring	20	14	850	420	ENCA4 AR/AR
	5/3 pressure centre	Pneumatic	Mechanical spring	20	14	690	420	ENCA4 PR/PR

*THE VALVES ARE SUPPLIED WITH O-RING

/EX Consistent with the ATEX directive II 2GD c T5 T100°C -20°C ≤ Ta ≤ 60°C E.G.: ENCA4 KR/ZR/EX

"NAMUR" PORT PATTERN - 5 PORT

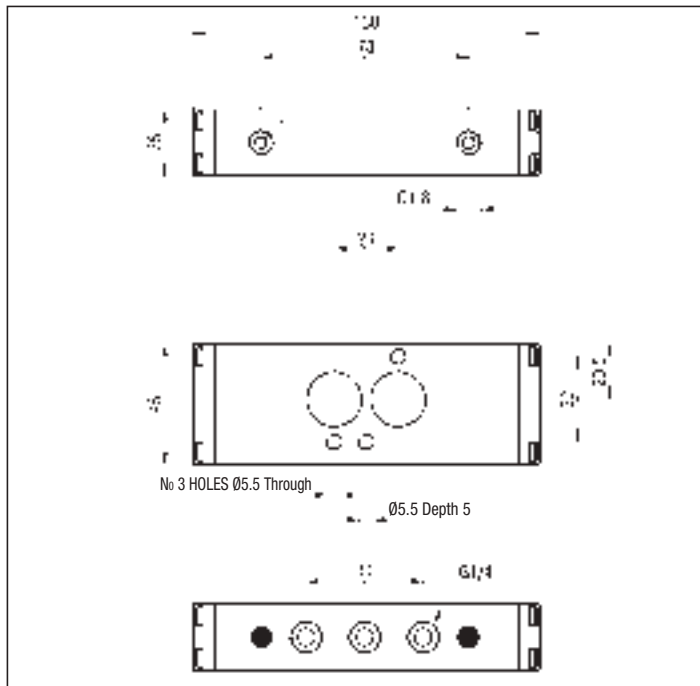

INTERFACE PLATE FOR "NAMUR"* - KIT/P/ENK

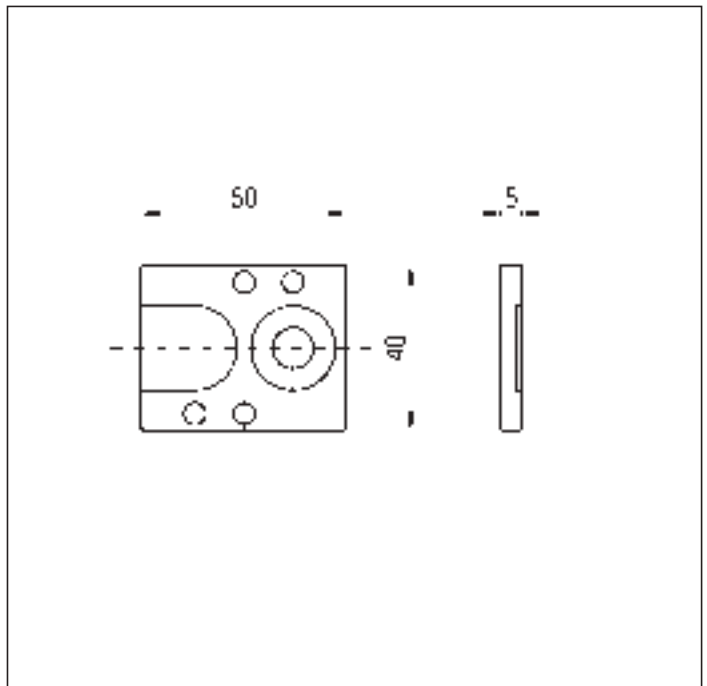

*To change the pneumatic function from 5/2 to 3/2.

2

SOLENOID ACTUATED VALVES G 1/4 - 3 PORT

Symbol	Function	Controls		Response time at 6 bar (ms)		Flow rate at 6 bar $\Delta P = 1 \text{ bar (l/min)}$	Weight (g)	TYPE*
		Pilot	Return	Energized	De-energized			
	3/2 N.O. monostable	Solenoid	Mechanical spring	22	60	950	385	EKA4 KUC/ZR
		Solenoid	Pneumatic spring	24	50	950	370	EKA4 KUC/TQ
		Solenoid pilot assisted	Mechanical spring	22	60	950	385	EKA4 KUR/ZR
	3/2 N.C. monostable	Solenoid	Mechanical spring	22	60	950	385	EKC4 KUC/ZR
		Solenoid	Pneumatic spring	24	50	950	370	EKC4 KUC/TQ
		Solenoid pilot assisted	Mechanical spring	22	60	950	385	EKC4 KUR/ZR
	3/2 bistable	Solenoid	Solenoid	23	23	950	405	EK4 KUC/KUC
		Solenoid pilot assisted	Solenoid pilot assisted	23	23	950	405	EK4 KUR/KUR

P.S.: SUBSTITUTE THE LETTER "U" WITH THE LETTER "L" IN EACH SOLENOID CONTROL TYPE TO ORDER THE SOLENOID ACTUATED VALVES WITH SOLENOID AT 90° RESPECT THE BODY OF THE VALVE. E.G.: EKC4 KUC/TQ BECOMES EKC4 KLC/TQ (SEE ON PAGE 2.74 FOR THE MISSING DIMENSIONS)
*THE TYPES OF THE SOLENOID VALVES DO NOT INCLUDE COILS

/EX Consistent with the ATEX directive II 2GD c T5 T100°C -20°C ≤ T_a ≤ 60°C E.G.: **EKA4 KUC/ZR/EX**

3 PORT MONOSTABLE

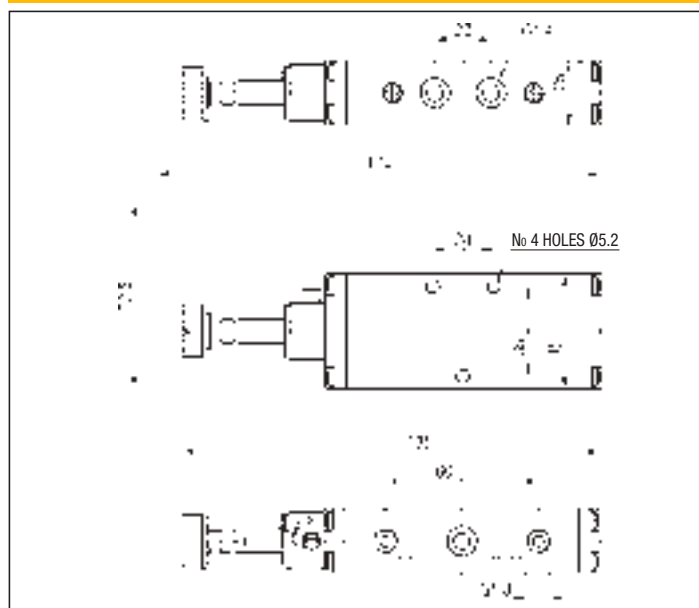

3 PORT BISTABLE

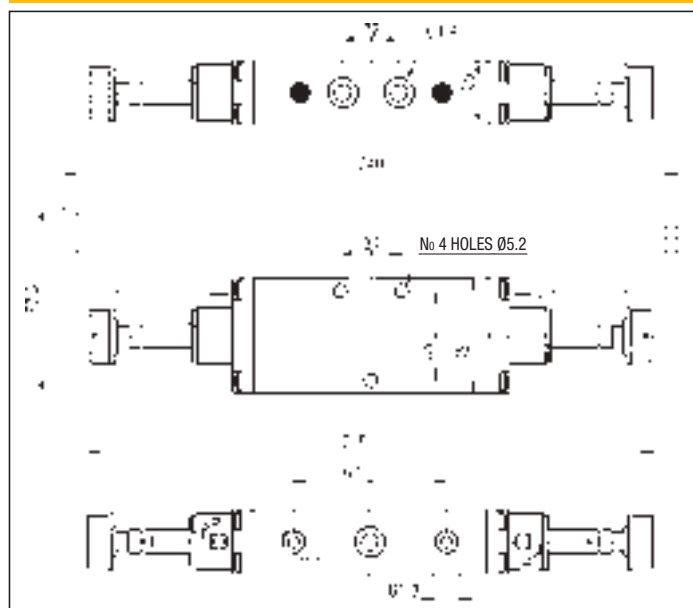

SOLENOID ACTUATED VALVES G 1/4 - 5 PORT

Symbol	Function	Controls		Response time at 6 bar (ms)		Flow rate at 6 bar $\Delta P = 1$ bar (l/min)	Weight (g)	TYPE*
		Pilot	Return	Energized	De-energized			
	5/2 monostable	Solenoid	Mechanical spring	32	65	900	430	EKCA4 KUC/ZR
		Solenoid	Pneumatic spring	32	65	900	415	EKCA4 KUC/TQ
		Solenoid pilot assisted	Mechanical spring	32	65	900	430	EKCA4 KUR/ZR
	5/2 bistable	Solenoid	Solenoid	21	21	900	475	EKCA4 KUC/KUC
		Solenoid pilot assisted	Solenoid pilot assisted	21	21	900	475	EKCA4 KUR/KUR
	5/3 closed centre	Solenoid	Mechanical spring	25	50	510	490	EKCA4 SUC/SUC
		Solenoid pilot assisted	Mechanical spring	25	50	510	490	EKCA4 SUR/SUR
	5/3 closed centre	Solenoid	Mechanical spring	25	50	850	485	EKCA4 AUC/AUC
		Solenoid pilot assisted	Mechanical spring	25	50	850	485	EKCA4 AUR/AUR
	5/3 pressure centre	Solenoid	Mechanical spring	25	50	690	490	EKCA4 PUC/PUC
		Solenoid pilot assisted	Mechanical spring	25	50	690	490	EKCA4 PUR/PUR

P.S.: SUBSTITUTE THE LETTER "U" WITH THE LETTER "L" IN EACH SOLENOID CONTROL TYPE TO ORDER THE SOLENOID ACTUATED VALVES WITH SOLENOID AT 90° RESPECT THE BODY OF THE VALVE.
 E.G.: **EKCA4 KUC/TQ** BECOMES **EKCA4 KLC/TQ** (SEE ON PAGE 2.74 FOR THE MISSING DIMENSIONS) - USE THE KIT/P/ENK TO CHANGE THE PNEUMATIC FUNCTION FROM 5/2 TO 3/2 (SEE ON PAGE 2.65).
 *THE TYPES OF THE SOLENOID VALVES DO NOT INCLUDE COILS /EX Consistent with the ATEX directive 2014/52/EU c T5 T100°C -20°C ≤ Ta ≤ 60°C E.G.: **EKCA4 KUC/ZR/EX**

5 PORT MONOSTABLE

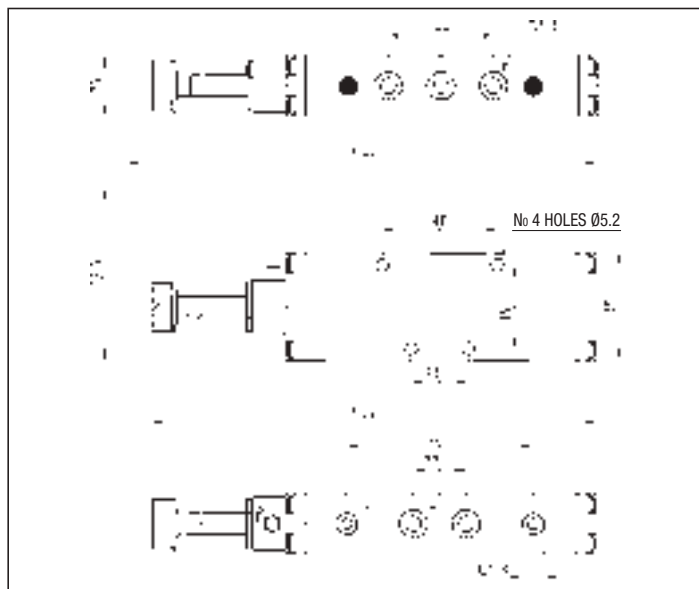

5 PORT AND 3 POSITIONS BISTABLE

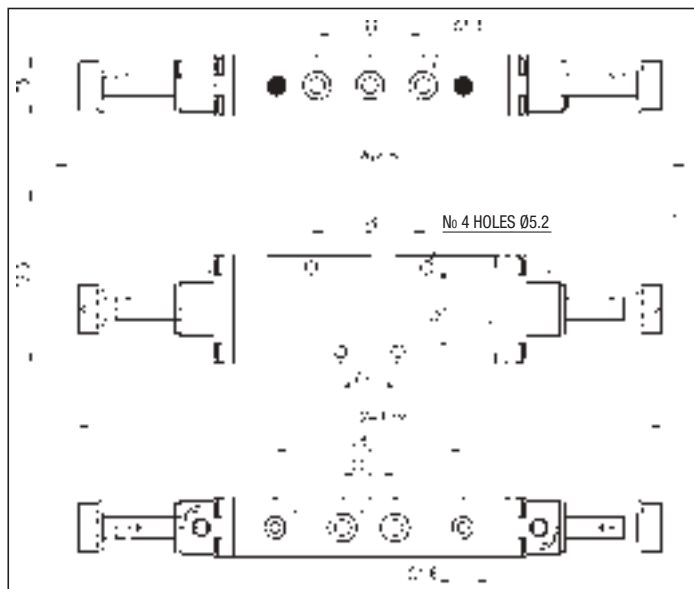

2

SOLENOID ACTUATED VALVES "NAMUR" PORT PATTERN G 1/4 - 5 PORT

Symbol	Function	Controls		Response time at 6 bar (ms)		Flow rate at 6 bar $\Delta P = 1$ bar (NI/min)	Weight (g)	TYPE*
		Pilot	Return	Energized	De-energized			
	5/2 monostable	Solenoid	Mechanical spring	32	65	900	440	ENCA4 KUC/ZR
		Solenoid	Pneumatic spring	32	65	900	425	ENCA4 KUC/TQ
		Solenoid pilot assisted	Mechanical spring	32	65	900	440	ENCA4 KUR/ZR
	5/2 bistable	Solenoid	Solenoid	21	21	900	485	ENCA4 KUC/KUC
		Solenoid pilot assisted	Solenoid pilot assisted	21	21	900	485	ENCA4 KUR/KUR
	5/3 closed centre	Solenoid	Mechanical spring	25	50	510	500	ENCA4 SUC/SUC
		Solenoid pilot assisted	Mechanical spring	25	50	510	500	ENCA4 SUR/SUR
	5/3 open centre	Solenoid	Mechanical spring	25	50	850	495	ENCA4 AUC/AUC
		Solenoid pilot assisted	Mechanical spring	25	50	850	495	ENCA4 AUR/AUR
	5/3 pressure centre	Solenoid	Mechanical spring	25	50	690	500	ENCA4 PUC/PUC
		Solenoid pilot assisted	Mechanical spring	25	50	690	500	ENCA4 PUR/PUR

PS.: SUBSTITUTE THE LETTER "U" WITH THE LETTER "L" IN EACH SOLENOID CONTROL TYPE TO ORDER THE SOLENOID ACTUATED VALVES WITH SOLENOID AT 90° RESPECT THE BODY OF THE VALVE. E.G.: **ENCA4 KUC/TQ** BECOMES **ENCA4 KLC/TQ** (SEE ON PAGE 2.74 FOR THE MISSING DIMENSIONS) *THE TYPES OF THE SOLENOID VALVES DO NOT INCLUDE COILS

/EX Consistent with the ATEX directive II 2GD c T5 T100°C -20°C ≤ Ta ≤ 60°C ES: **ENCA4 KUC/ZR/EX**

THE VALVES ARE SUPPLIED WITH O-RING

"NAMUR" PORT PATTERN - 5 PORT MONOSTABLE

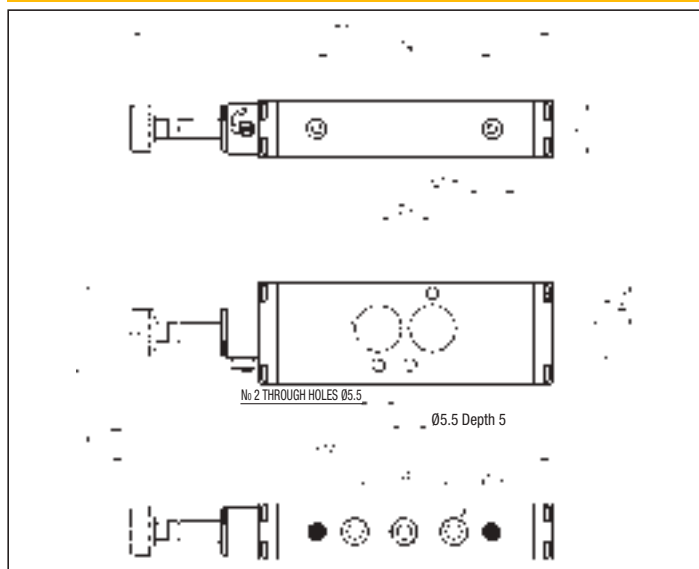

"NAMUR" PORT PATTERN - 5 PORT AND 3 POSITIONS BISTABLE

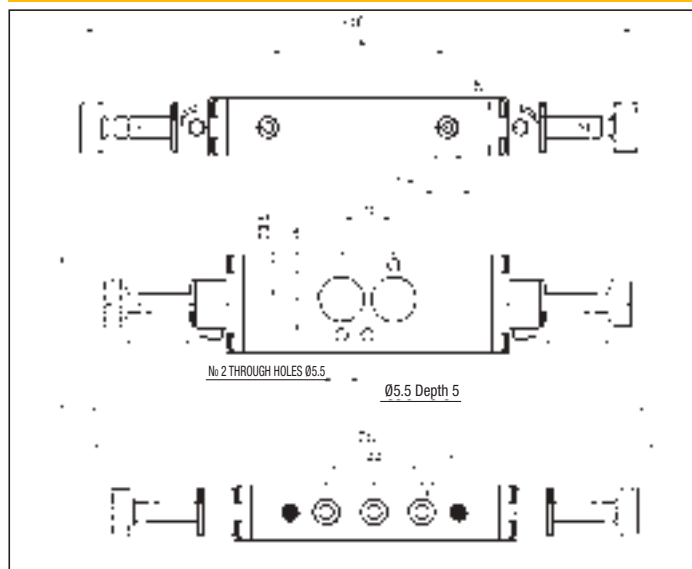

BASE FOR MANIFOLD MOUNTING OF VALVES G 1/4 - KB/EK4

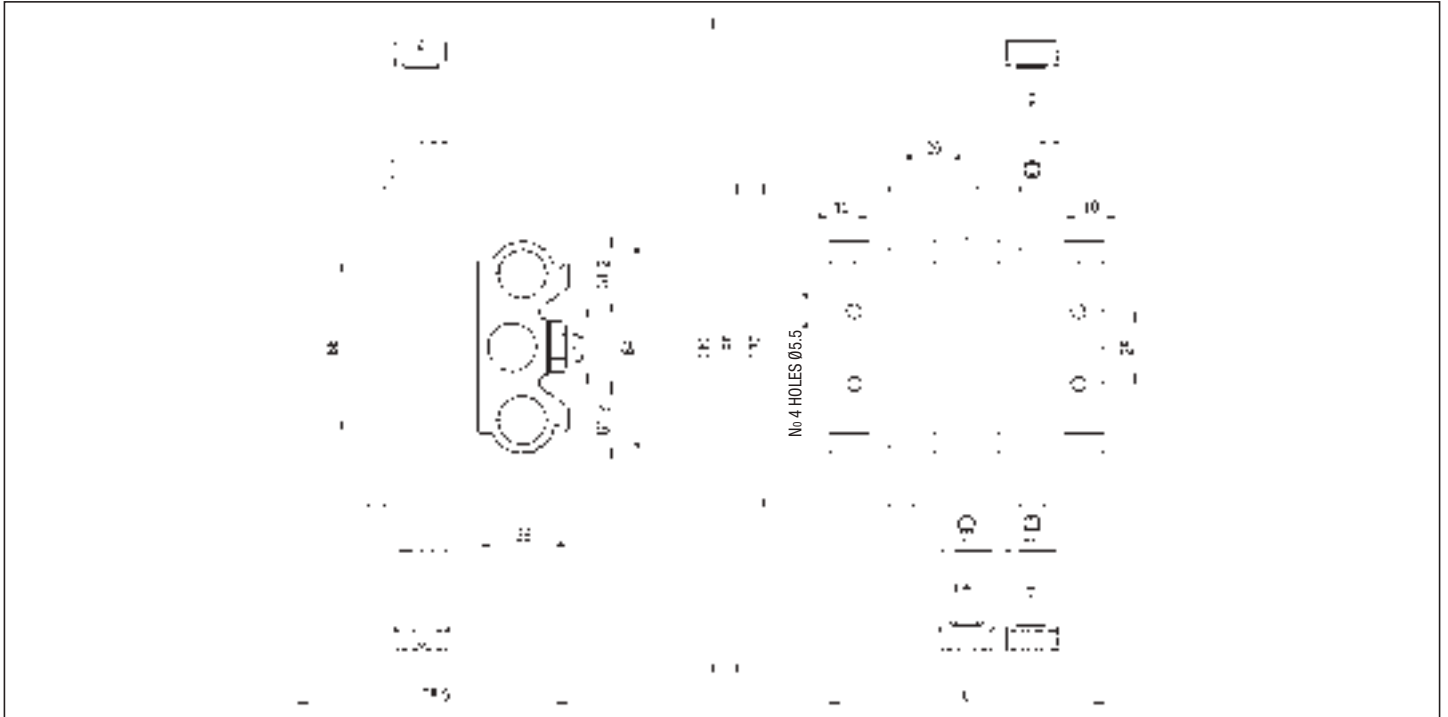

No of stations	2	3	4	5	6	8	10	12	14	16	18	20
L	83	109	135	161	187	239	291	343	395	447	499	551
Weight (g)	460	590	720	850	980	1240	1500	1760	2020	2280	2540	2800
TYPE*	KB/EK4/2	KB/EK4/3	KB/EK4/4	KB/EK4/5	KB/EK4/6	KB/EK4/8	KB/EK4/10	KB/EK4/12	KB/EK4/14	KB/EK4/16	KB/EK4/18	KB/EK4/20

*BASES ARE SUPPLIED COMPLETE WITH NOTCH SCREWS AND SEALS

SUPPLY RAIL FOR MANIFOLD MOUNTING OF VALVES G 1/4 - CEK4

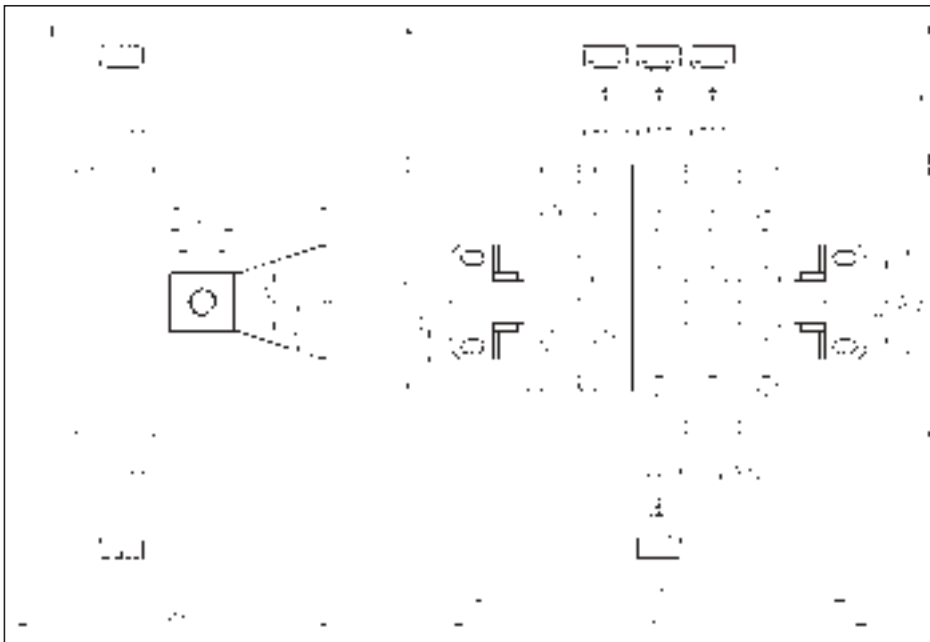

BLANKING PLATE - KIT/PC/EK4

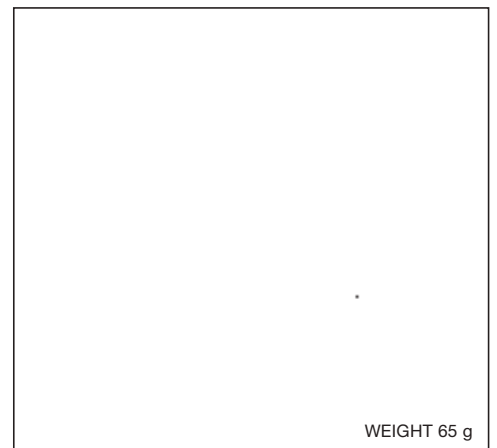

No of stations	2	3	5
LA	99	125	176
LB	119	145	196
Weight (g)	310	390	550
TYPE*	CEK4/2	CEK4/3	CEK4/5

* SUPPLY RAILS ARE SUPPLIED COMPLETE WITH NOTCH SCREWS, SEALS AND FIXING BRACKETS
P.S.: CAN BE MOUNTED ONLY SILENCERS SERIES **SS-02** (SEE THE HIDDEN SILENCERS ON PAGE 5.52)

2

SOLENOID ACTUATED VALVES G 1/4 - 5 PORT

Symbol	Function	Controls		Response time at 6 bar (ms)		Flow rate at 6 bar $\Delta P = 1$ bar (NI/min)	Weight (g)	TYPE*
		Pilot	Return	Energized	De-energized			
	5/2 monostable	Solenoid	Pneumomechanical spring	45	35	1400	480	EKCA30 KUC/ZQ
		Solenoid	Pneumatic spring	40	40	1400	480	EKCA30 KUC/TQ
	5/2 bistable	Solenoid	Solenoid	20	20	1400	470	EKCA30 KUC/KUC
	5/3 closed centre	Solenoid	Mechanical spring	30	35	1100	550	EKCA30 SUC/SUC
	5/3 open centre	Solenoid	Mechanical spring	30	35	1100	550	EKCA30 AUC/AUC
	5/3 pressure centre	Solenoid	Mechanical spring	30	35	1100	550	EKCA30 PUC/PUC

P.S.: SUBSTITUTE THE LETTER "U" WITH THE LETTER "L" IN EACH SOLENOID CONTROL TYPE TO ORDER THE SOLENOID ACTUATED VALVES WITH SOLENOID AT 90° RESPECT THE BODY OF THE VALVE. E.G.: **EKCA30 KUC/TQ** BECOMES **EKCA30 KLC/TQ** (SEE ON PAGE 2.74 FOR THE MISSING DIMENSIONS)

*THE TYPES OF THE SOLENOID VALVES DO NOT INCLUDE COILS

/EX Consistent with the ATEX directive II 2GD c T5 T100°C -20°C ≤ Ta ≤ 60°C

E.G.: **EKCA30 KUC/ZQ/EX**

5 PORT MONOSTABLE

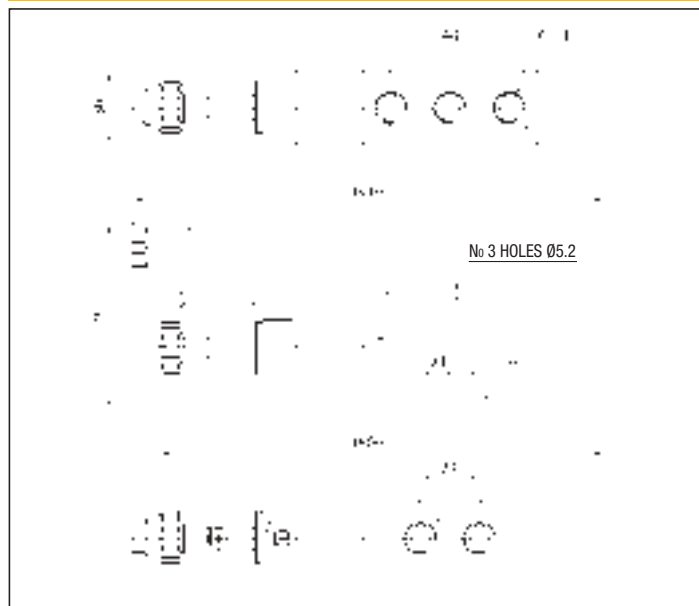

5 PORT BISTABLE

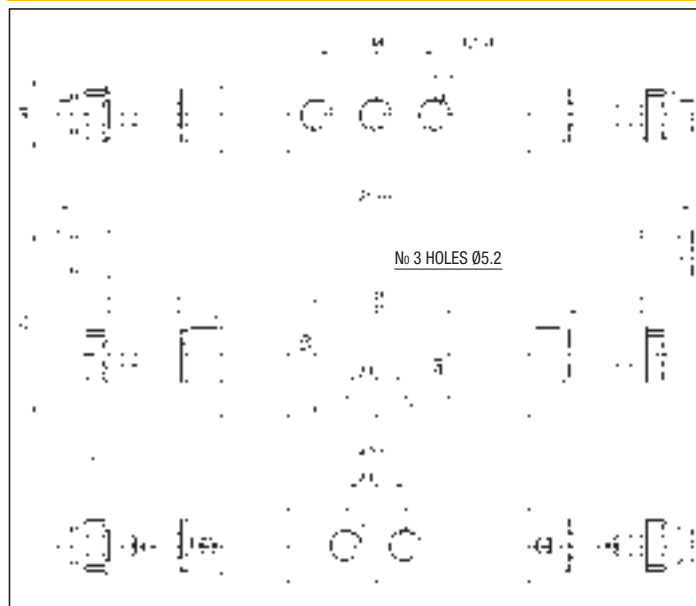

SPARE PARTS

SEALS KIT	
5/2 - G 1/4	EKCA30/SG
5/3 - G 1/4	EKCA30/SG - 5/3

PILOT ACTUATED VALVES G 1/2 - 3 PORT

Symbol	Function	Controls		Response time at 6 bar (ms)		Flow rate at 6 bar $\Delta P = 1 \text{ bar (Nl/min)}$	Weight (g)	TYPE*
		Pilot	Return	Energized	De-energized			
	3/2 N.O. monostable	Pneumatic	Pneumomechanical spring	21	27	2400	770	EKA2 KR/ZQ
	3/2 N.O. monostable	Pneumatic	Pneumatic spring	21	27	2400	760	EKA2 KR/TQ
	3/2 N.C. monostable	Pneumatic	Pneumomechanical	21	27	2200	770	EKC2 KR/ZQ
	3/2 N.C. monostable	Pneumatic	Pneumatic spring	21	27	2200	760	EKC2 KR/TQ
	3/2 bistable	Pneumatic	Pneumatic	20	20	2200	790	EK2 KR/KR

2

*/EX Consistent with the ATEX directive II 2GD c T5 T100°C -20°C ≤ Ta ≤ 60°C E.G.: EKA2 KR/ZQ/EX

PILOT ACTUATED VALVES G 1/2 - 5 PORT

Symbol	Function	Controls		Response time at 6 bar (ms)		Flow rate at 6 bar $\Delta P = 1 \text{ bar (Nl/min)}$	Weight (g)	TYPE*
		Pilot	Return	Energized	De-energized			
	5/2 monostable	Pneumatic	Pneumomechanical spring	21	27	2800	1010	EKCA2 KR/ZQ
		Pneumatic	Pneumatic spring	21	27	2800	1000	EKCA2 KR/TQ
	5/2 bistable	Pneumatic	Pneumatic	20	20	2800	1000	EKCA2 KR/KR
	5/3 closed centre	Pneumatic	Pneumatic spring	20	25	1700	1020	EKCA2 SR/SR

*/EX Consistent with the ATEX directive II 2GD c T5 T100°C -20°C ≤ Ta ≤ 60°C E.G.: EKCA2 KR/ZQ/EX

3 PORT

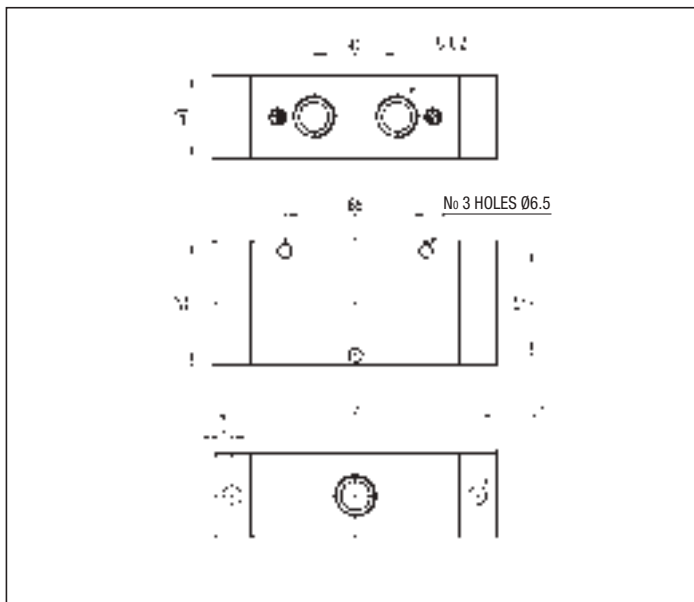

5 PORT

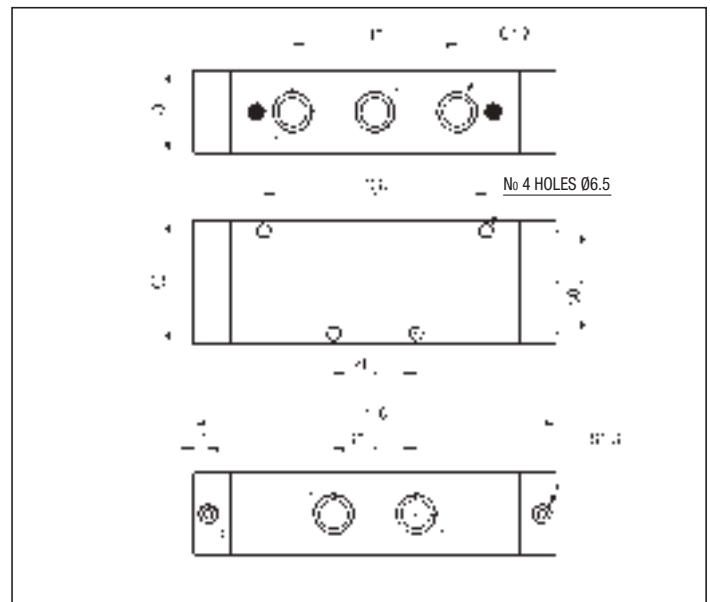

2

SOLENOID ACTUATED VALVES G 1/2 - 3 PORT

Symbol	Function	Controls		Response time at 6 bar (ms)		Flow rate at 6 bar $\Delta P = 1$ bar (l/min)	Weight (g)	TYPE*
		Pilot	Return	Energized	De-energized			
	3/2 N.O. monostable	Solenoid	Pneumomechanical spring	30	90	2400	800	EKA2 KUC/ZQ
		Solenoid pilot assisted	Pneumomechanical spring	30	90	2400	800	EKA2 KUR/ZQ
		Solenoid	Pneumatic spring	30	90	2400	790	EKA2 KUC/TQ
	3/2 N.C. monostable	Solenoid	Pneumomechanical spring	30	90	2200	800	EKC2 KUC/ZQ
		Solenoid pilot assisted	Pneumomechanical spring	30	90	2200	800	EKC2 KUR/ZQ
		Solenoid	Pneumatic spring	30	90	2200	790	EKC2 KUC/TQ
	3/2 bistable	Solenoid	Solenoid	25	25	2200	850	EK2 KUC/KUC
		Solenoid pilot assisted	Solenoid pilot assisted	25	25	2200	850	EK2 KUR/KUR

P.S.: SUBSTITUTE THE LETTER "U" WITH THE LETTER "L" IN EACH SOLENOID CONTROL TYPE TO ORDER THE SOLENOID ACTUATED VALVES WITH SOLENOID AT 90° RESPECT THE BODY OF THE VALVE. E.G.: **EKA2 KUC/TQ** BECOMES **EKA2 KLC/TQ** (SEE ON PAGE 2.74 FOR THE MISSING DIMENSIONS)

*THE TYPES OF THE SOLENOID VALVES DO NOT INCLUDE COILS

/EX Consistent with the ATEX directive II 2GD c T5 T100°C -20°C ≤ T_a ≤ 60°C E.G.: **EKA2 KUC/ZQ/EX**

3 PORT MONOSTABLE

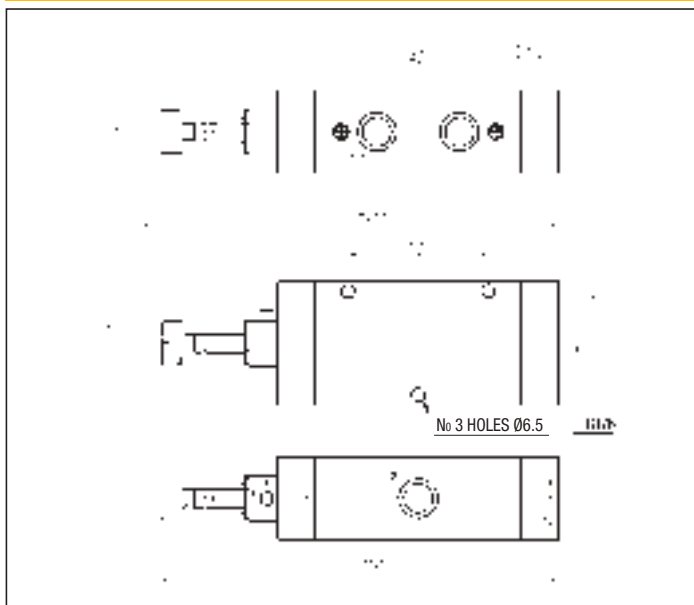

3 PORT BISTABLE

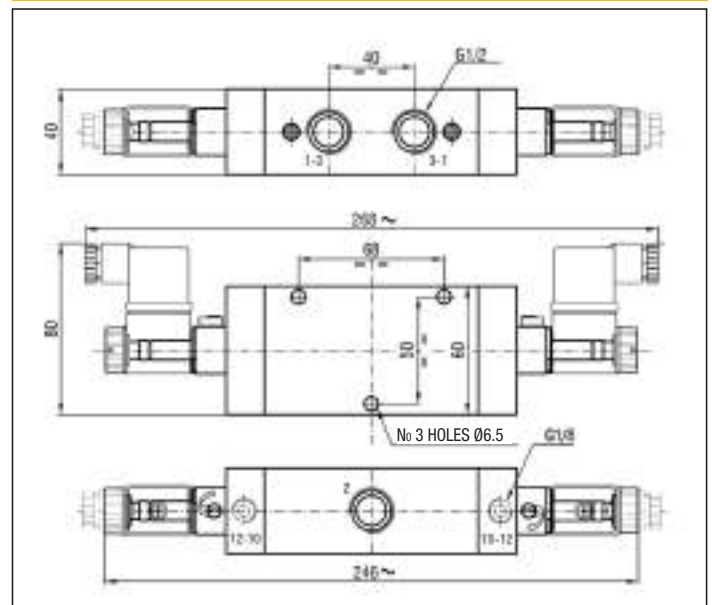

SOLENOID ACTUATED VALVES G 1/2 - 5 PORT

Symbol	Function	Controls		Response time at 6 bar (ms)		Flow rate at 6 bar $\Delta P = 1 \text{ bar (Nl/min)}$	Weight (g)	TYPE*
		Pilot	Return	Energized	De-energized			
	5/2 monostable	Solenoid	Pneumomechanical spring	30	90	2800	1025	EKCA2 KUC/ZQ
		Solenoid	Pneumatic spring	30	90	2800	1015	EKCA2 KUC/TQ
		Solenoid pilot assisted	Pneumomechanical spring	30	90	2800	1025	EKCA2 KUR/ZQ
	5/2 bistable	Solenoid	Solenoid	25	25	2800	1075	EKCA2 KUC/KUC
		Solenoid pilot assisted	Solenoid pilot assisted	25	25	2800	1075	EKCA2 KUR/KUR
	5/3 closed centre	Solenoid	Mechanical spring	25	80	1700	1085	EKCA2 SUC/SUC
		Solenoid pilot assisted	Mechanical spring	25	80	1700	1085	EKCA2 SUR/SUR

PS.: SUBSTITUTE THE LETTER "U" WITH THE LETTER "L" IN EACH SOLENOID CONTROL TYPE TO ORDER THE SOLENOID ACTUATED VALVES WITH SOLENOID AT 90° RESPECT THE BODY OF THE VALVE. E.G.: **EKCA2 KUC/TQ** BECOMES **EKCA2 KLC/TQ** (SEE ON PAGE 2.74 FOR THE MISSING DIMENSIONS)
 *THE TYPES OF THE SOLENOID VALVES DO NOT INCLUDE COILS

/EX Consistent with the ATEX directive II 2GD c T5 T100°C -20°C ≤ Ta ≤ 60°C E.G.: **EKCA2 KUC/ZQ/EX**

5 PORT MONOSTABLE

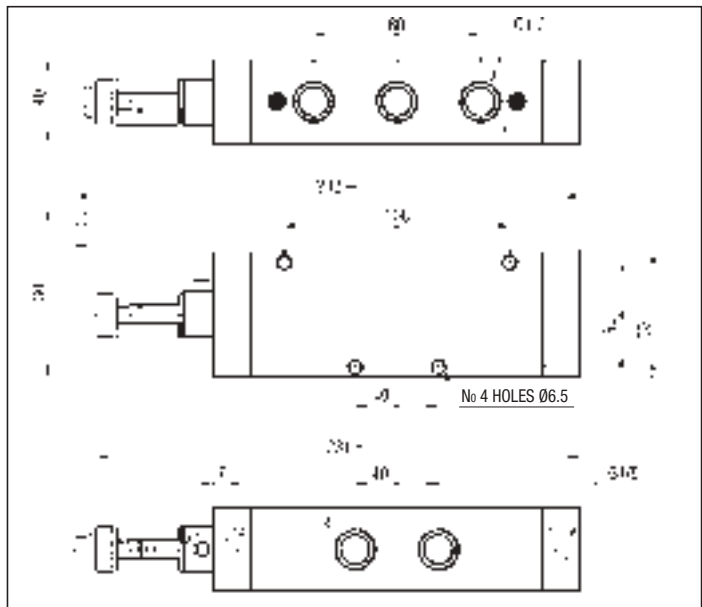

5 PORT BISTABLE AND 3 POSITIONS

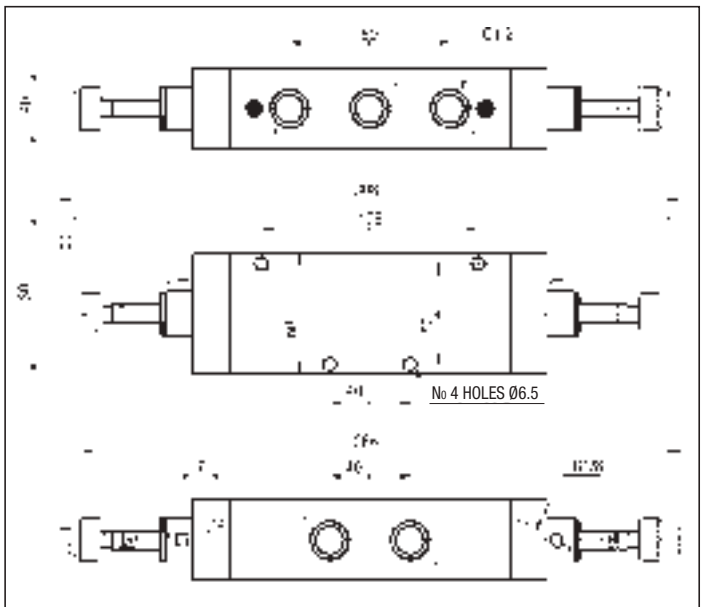

SOLENOID ACTUATED VALVES WITH SOLENOID AT 90°

SUBSTITUTE THE LETTER "U" WITH THE LETTER "L" IN EACH SOLENOID CONTROL TYPE TO ORDER THE SOLENOID ACTUATED VALVES WITH SOLENOID AT 90° RESPECT THE BODY OF THE VALVE. E.G.: **EKCA2 KUC/TQ** BECOMES **EKCA2 KLC/TQ**

2

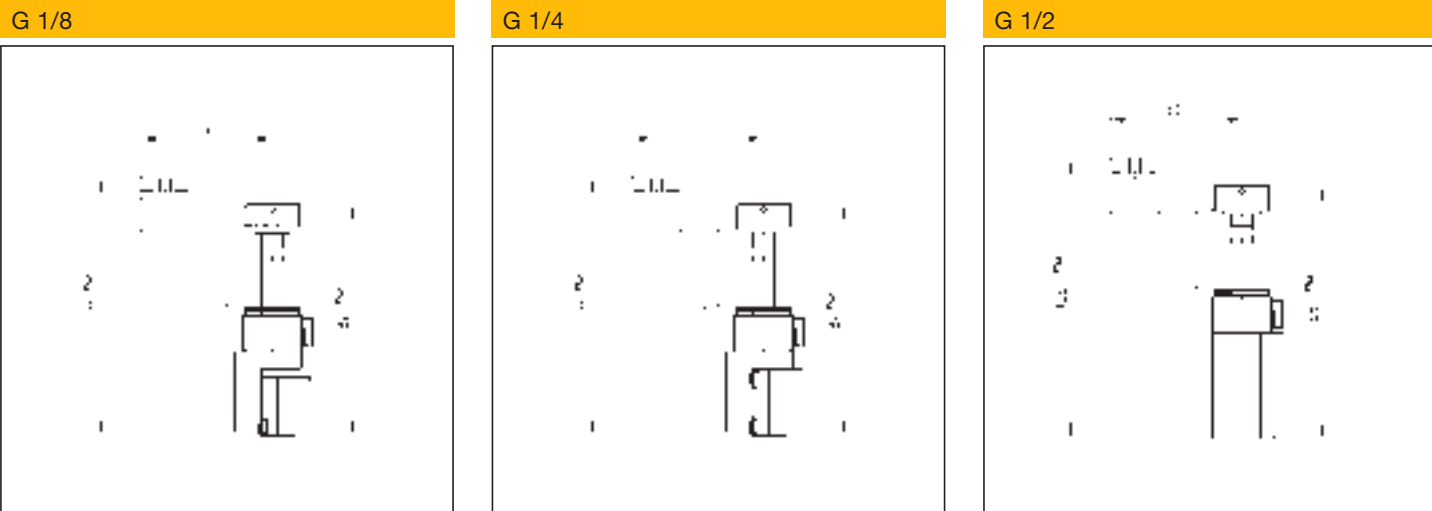

ACCESSORIES

MOUNTING BRACKET FOR PILOT AND SOLENOID ACTUATED VALVES TYPES EK 4 - EK 8 ON CYLINDER SERIES "XT" (see from page 1.25)

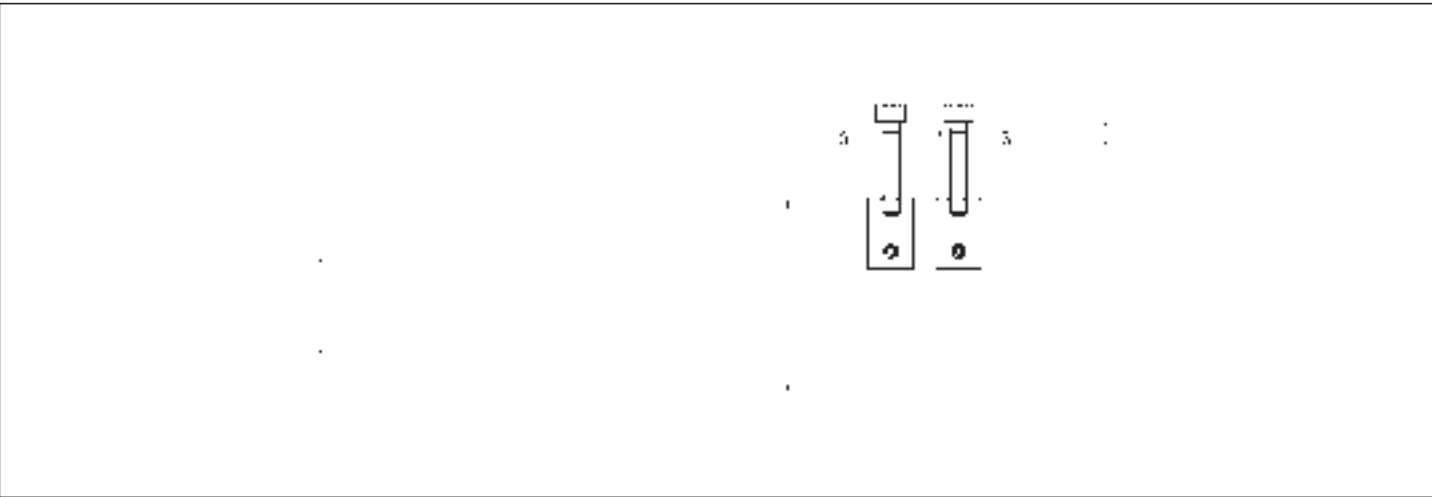

Ø CYLINDER	L	TYPE*
32	50,5	SQ32-40/EK
40	57,5	
50	69	SQ50-63/EK
63	79,5	
80	95,5	SQ80-100/EK
100	113	

* BRACKETS ARE SUPPLIED COMPLETE WITH DOWELS AND SCREWS
P.S.: PLEASE CHECK BEFORE ORDERING THE COUPLED DIMENSIONS OF THE CYLINDER WITH THE VALVE

2

DESCRIPTION

Valves series "UK" are produced in the 2/2, 3/2 and 5/2 monostable pneumatic functions. In the 3 port solenoid control version with small pilot system, sizes G 1/8 and G 1/4, support the 15 mm direct acting solenoid valve (type UMCSV with fixed position). All the other electric versions can support the 32 mm direct acting solenoid valve, type ULCSV/R (with fixed position), type C/USCSVG with sleeve \varnothing 9 mm (with fixed position and rotatable coils series USB and USBG) or the amplifier valve XVF4 for a sensible pneumatic piloting (see page 3.37). The 3/2 N.C. pilot actuated valves can also be used to switch vacuum thanks to a suitably reinforced spring.

The poppet design assures high flow and high life. This series of valves, in the sizes G 1/8, G 1/4 and G 1/2, is prearranged for base mounting with conveyed inlet by means of rear notch screws.

Upon request they comply with ATEX directive: 2GD category for pilot and solenoid actuated valves with coil type "USBG2" and 3GD category for the solenoid actuated valves with other coils type.

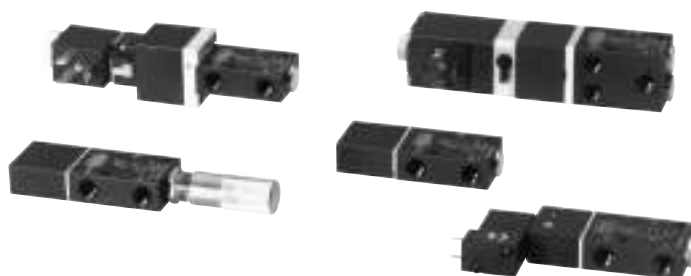

TECHNICAL DATA

Operating pressure	Solenoid actuated: 1,5 ÷ 10 bar Pilot actuated: 1,5 ÷ 12 bar
Working temperature	0 ÷ +70 °C (-20 °C with dry air)
Fluid	Compressed air, filtered, continuous lubricated, unlubricated or dry lubricated - vacuum
Port size	G 1/8 - G 1/4 - G 1/2 - G 1
Pneumatic piloting port size	G 1/8
Nominal diameter	G 1/8 = 6 mm; G 1/4 = 8,5 mm G 1/2 = 12 mm; G 1 = 23 mm
Piloting solenoid valves	UMCSV - see chapter direct acting solenoid valves on page 2.5 ULCSV/R - see chapter direct acting solenoid valves on page 2.8 C/USCSVG - see chapter direct acting solenoid valves on page 2.16
Pneumatic piloting valve	XVF4 - see chapter complementary valves on page 3.37
Coils (only for C/USCSVG)	USB - see chapter coils on page 2.17 USBG - see chapter coils on page 2.17 USBG2 - see chapter coils on page 2.17
Electric connectors	USR102/N9 - see chapter connectors on page 2.18 ULR1B - see chapter connectors on page 2.18 MEK192/N - see chapter connectors on page 2.18

MATERIALS

Control rod	Hardened and nickel-plated steel
Body	Anodized aluminium alloy
Molle	Acciaio INOX
Seals	NBR rubber
Bush rod	Brass
Piston	Acetal resin
Terminal strip	Acetal resin
Washer	Brass
End plug	Nickel-plated brass
Clamping screws	Steel

PILOTING CHART - UK G 1/8

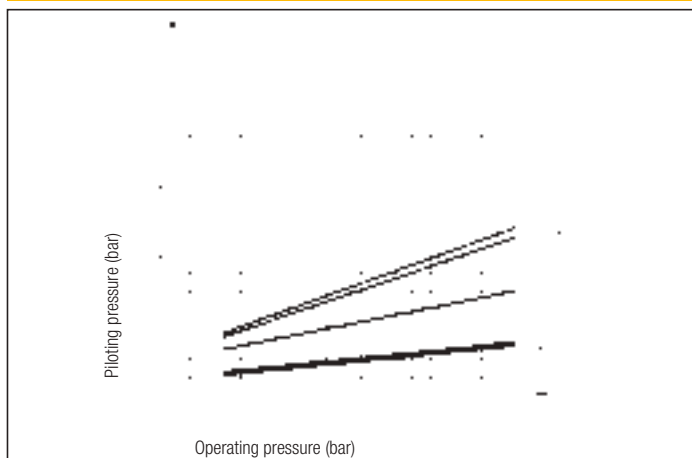

FLOW CHART - UK G 1/8 - 5/2

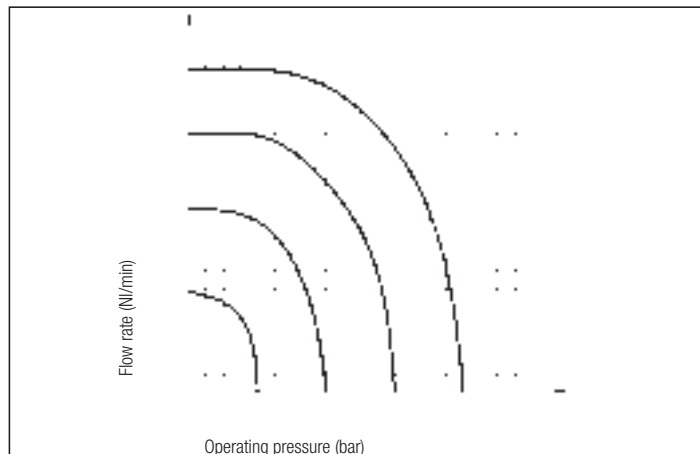

PILOTING CHART - UK G1/4

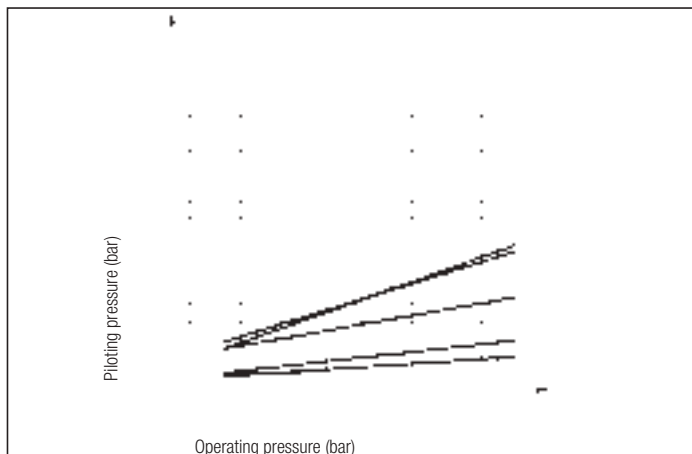

FLOW CHART - UK G 1/4 - 5/2

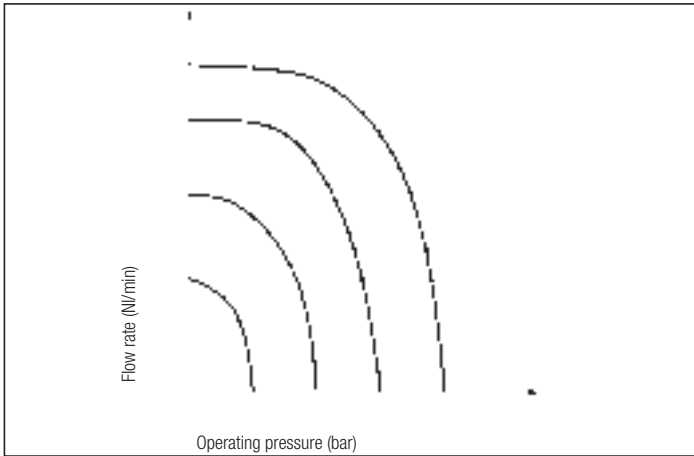

PILOTING CHART - UK G 1/2

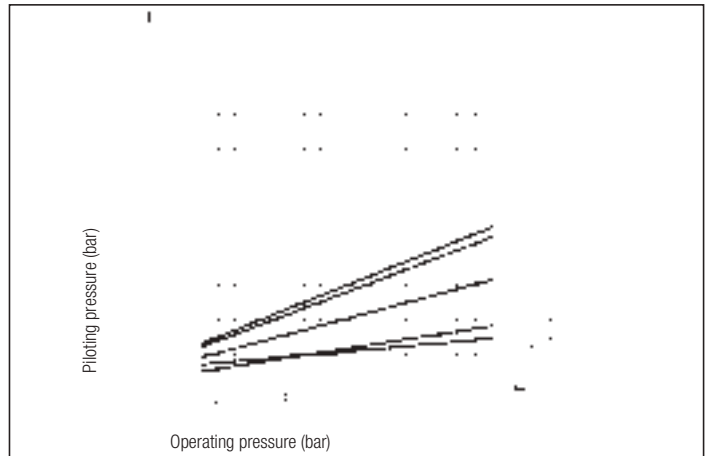

FLOW CHART - UK G 1/2 - 5/2

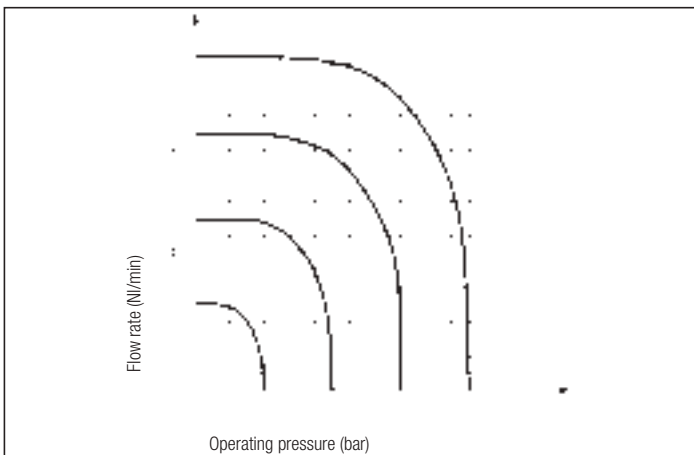

PILOTING CHART - UK G 1

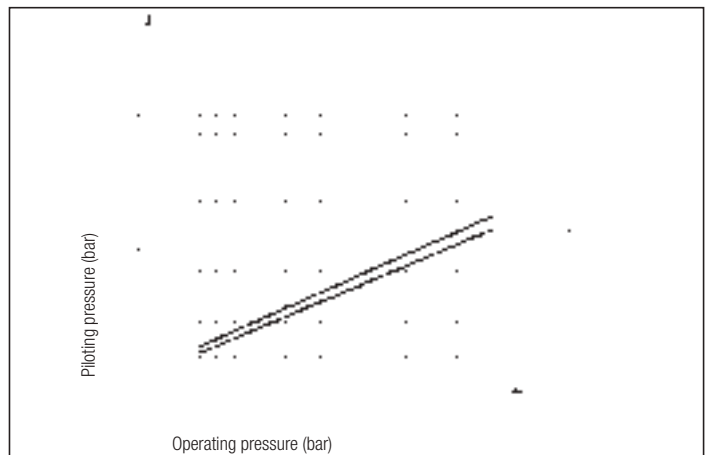

FLOW CHART - UK G 1 - 5/2

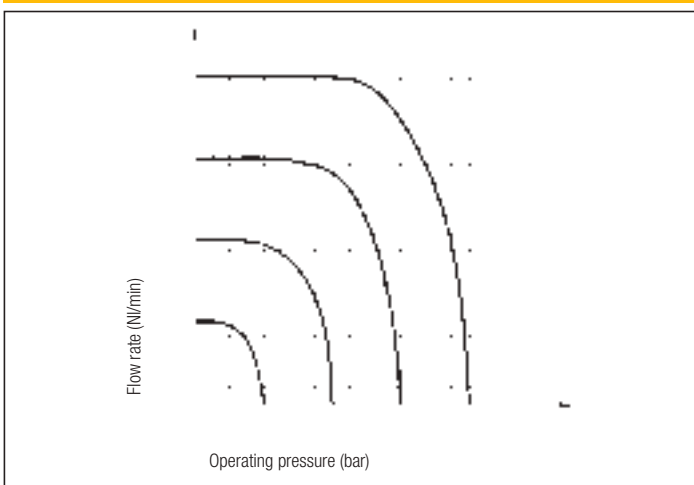

SPARE PARTS

SEALS KIT	
3/2 N.O. G 1/8 small pilot system	UKA/12/SG/8
3/2 N.C. G 1/8 small pilot system	UKC/12/SG/8
3/2 N.O. G 1/8 big pilot system	UKA/25/SG/8
3/2 N.C. G 1/8 big pilot system	UKC/25/SG/8
5/2 G 1/8	UKCA/SG/8
3/2 N.O. G 1/4 small pilot system	UKA/16/SG/4
3/2 N.C. G 1/4 small pilot system	UKC/16/SG/4
3/2 N.O. G 1/4 big pilot system	UKA/32/SG/4
3/2 N.C. G 1/4 big pilot system	UKC/32/SG/4
5/2 G 1/4	UKCA/SG/4
3/2 N.O. G 1/2 small pilot system	UKA/20/SG/2
3/2 N.C. G 1/2 small pilot system	UKC/20/SG/2
3/2 N.O. G 1/2 big pilot system	UKA/40/SG/2
3/2 N.C. G 1/2 big pilot system	UKC/40/SG/2
5/2 G 1/2	UKCA/SG/2
3/2 N.O. G 1	UKA/SG/1
3/2 N.C. G 1	UKC/SG/1

2

PILOT ACTUATED VALVES G 1/8 - 2, 3 and 5 PORT

Symbol	Function	Controls		Response time at 6 bar (ms)		Flow rate at 6 bar $\Delta P = 1$ bar (l/min)	Weight (g)	TYPE*
		Pilot	Return	Energized	De-energized			
	3/2 N.O. monostable	Small pneumatic	Mechanical spring	18	34	700	115	UKA 8/12
	3/2 N.C. monostable	Small pneumatic	Mechanical spring	20	29	700	115	UKC 8/12
		Servo fed small pneumatic	Mechanical spring	20	29	700	115	UKC 8/12/SA
		Adjustable small pneumatic	Mechanical spring	-	-	700	180	UKC 8/12/T
	3/2 N.O. monostable	Big pneumatic	Mechanical spring	18	38	700	135	UKA 8/25
	3/2 N.C. monostable	Big pneumatic	Mechanical spring	18	38	700	135	UKC 8/25
		Servo fed big pneumatic	Mechanical spring	18	38	700	135	UKC 8/25/SA
		Adjustable big pneumatic	Mechanical spring	-	-	700	200	UKC 8/25/T
	5/2 monostable	Pneumatic	Mechanical spring	19	40	650	195	UKCA8
		Servo fed pneumatic	Mechanical spring	19	40	650	195	UKCA8/SA

*EX Consistent with the ATEX directive II 2GD c T5 T100°C -20°C ≤ Ta ≤ 60°C E.G.: **UKCA8/EX**

PS.: ADD AT THE TYPE OF THE VALVES 3/2 THE LETTER "H" BETWEEN THE LETTERS "K" AND "A" (OR "C") TO ORDER 2/2 N.O. (OR 2/2 N.C.) VALVES.

E.G.: **UKHA 8/12; UKHC 8/25**

3 PORT SMALL PNEUMATIC

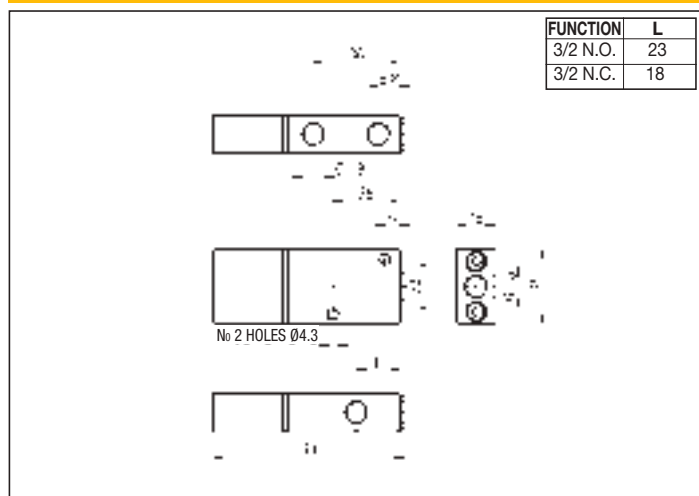

3 PORT BIG PNEUMATIC

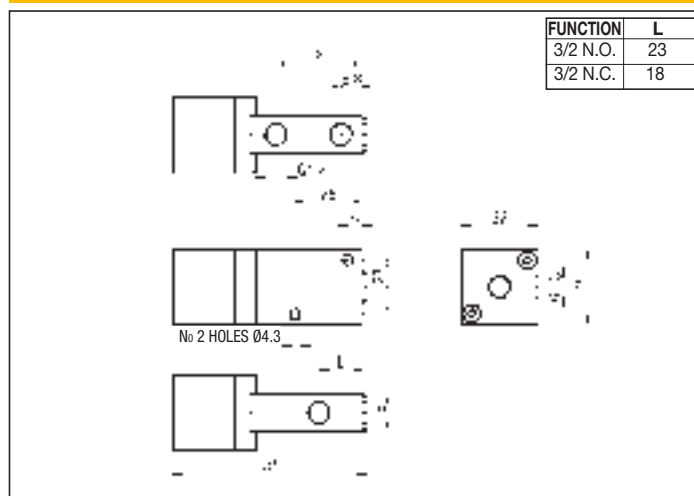

UKC 8/12/T

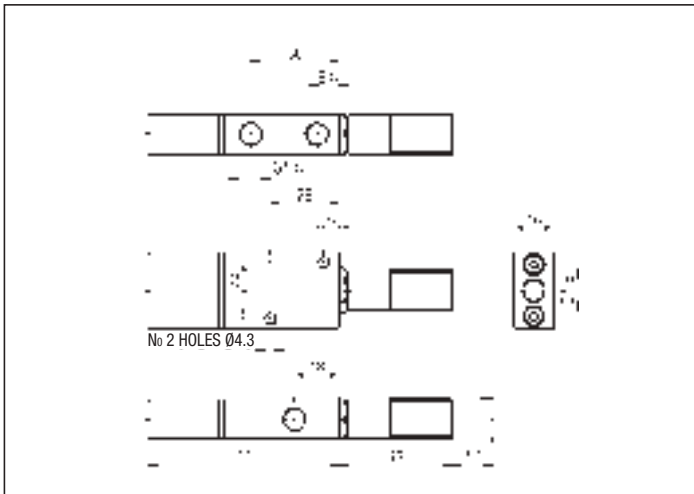

UKC 8/25/T

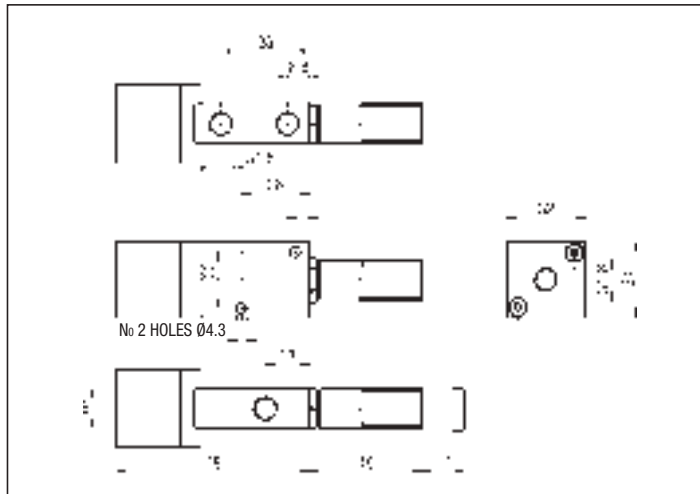

2

SPRING CALIBRATION UKC 8/12/T

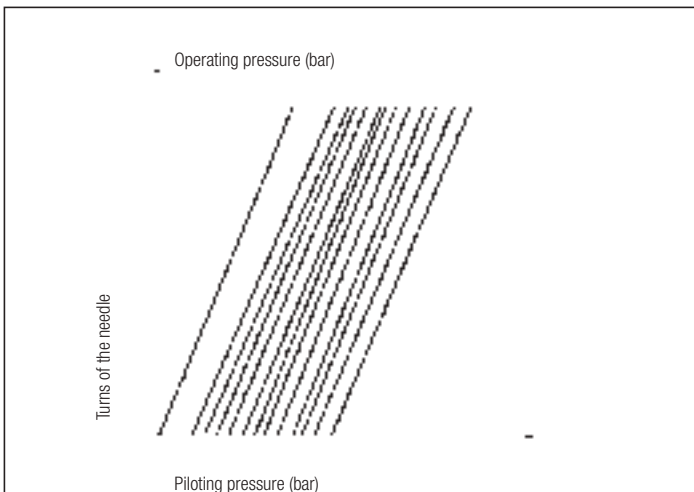

SPRING CALIBRATION UKC 8/25/T

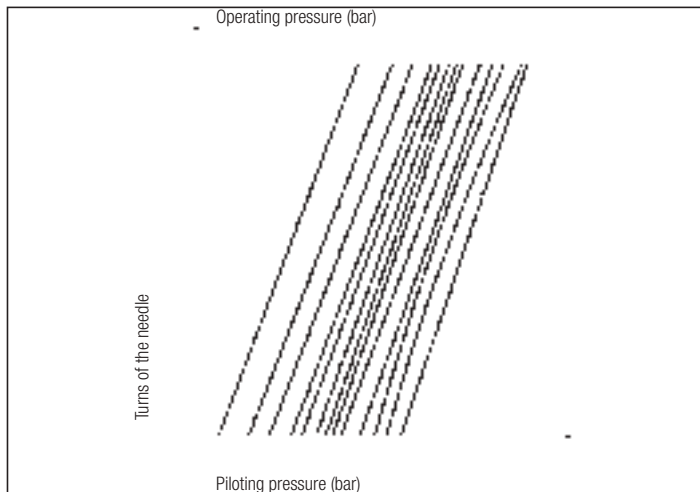

5 PORT

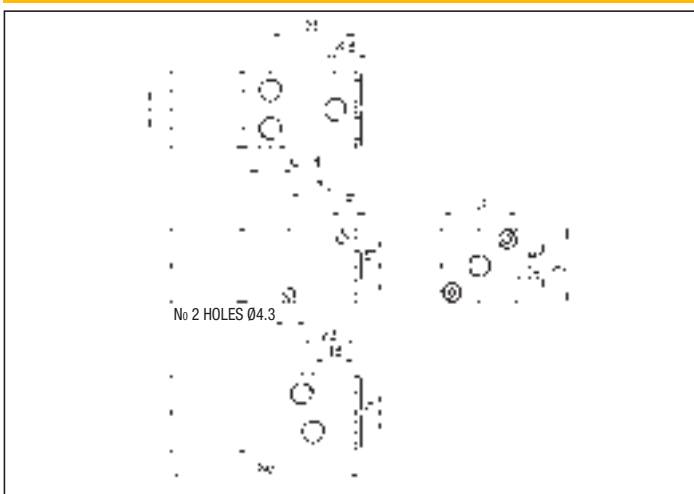

2

SOLENOID ACTUATED VALVES G 1/8 - 2, 3 and 5 PORT

Symbol	Function	Controls		Response time at 6 bar (ms)		Flow rate at 6 bar $\Delta P = 1$ bar (l/min)	Weight (g)	TYPE*
		Pilot	Return	Energized	De-energized			
	3/2 N.O. monostable	Small solenoid	Mechanical spring	10	28	700	108	UKA 8/12/U**
	3/2 N.C. monostable	Small solenoid	Mechanical spring	10	28	700	108	UKC 8/12/U**
	3/2 N.O. monostable	Big solenoid	Mechanical spring	18	38	700	135	UKA 8/25/U***
	3/2 N.C. monostable	Big solenoid	Mechanical spring	18	38	700	135	UKC 8/25/U***
	5/2 monostable	Solenoid	Mechanical spring	19	40	650	203	UKCA 8/U***

*EX Consistent with the ATEX directive II 2GD c T5 T100°C -20°C ≤ T ≤ 60°C E.G.: UKCA8/U/EX /EX Consistent with the ATEX directive II 3G c Ex nA IIC T5 Gc -5°C ≤ T ≤ 50°C II 3D c Ex tc IIIC T100°C IP65 Dc E.G.: UKA8/12/U2400/EX

** TYPES OF THESE SOLENOID VALVES INCLUDE THE PILOTING SOLENOID VALVES "UMCSV" - SEE ON PAGE 2.5 (SPECIFY THE VOLTAGE IN THE ORDER)
 *** TYPES OF THESE SOLENOID VALVES DO NOT INCLUDE THE PILOTING SOLENOID VALVES (SEE ON PAGE 2.9 FOR "ULCSV/R" AND ON PAGE 2.16 FOR "C/USCSVG") WHEREAS USING AS PILOT THE VALVE "XVF4" THE RESULT IS A LOW PRESSURE PILOT ACTUATED VALVE (FOR "XVF4" - SEE ON PAGE 3.37)
 P.S.: ADD AT THE TYPE OF THE VALVES 3/2 THE LETTER "H" BETWEEN THE LETTERS "K" AND "A" (OR "C") TO ORDER 2/2 N.O. (OR 2/2 N.C.) VALVES. E.G.: UKHA 8/12/U; UKHC 8/25/U

3 PORT SMALL SOLENOID

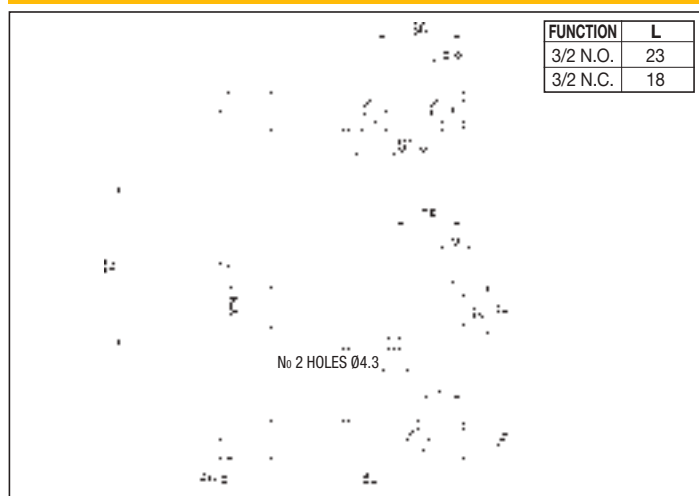

3 PORT BIG SOLENOID WITH ULCSV/R

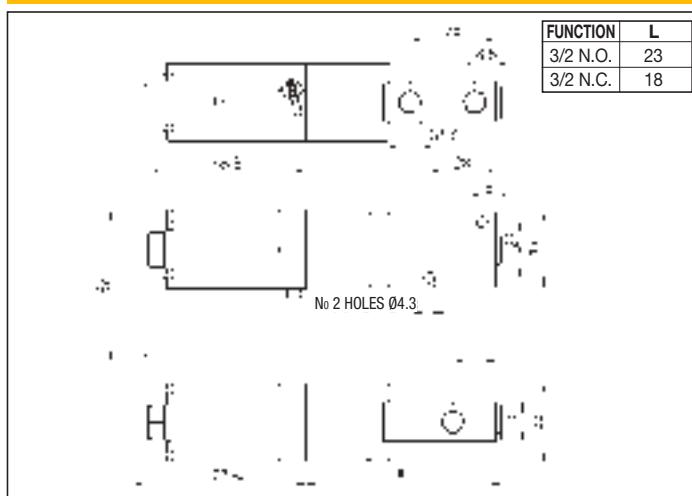

3 PORT BIG SOLENOID WITH C/USCSVG

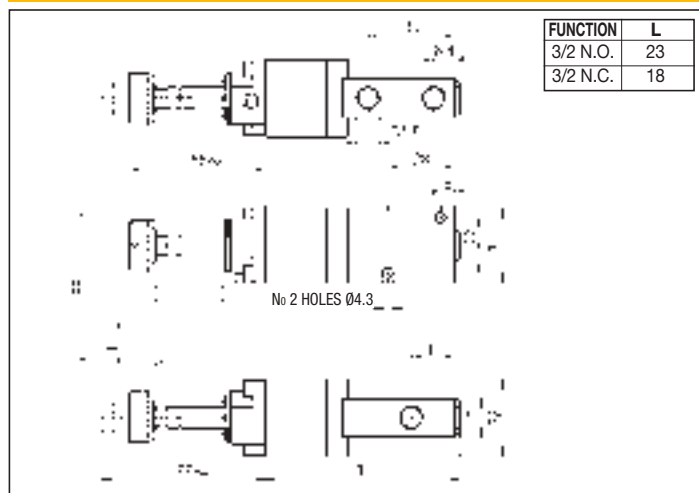

3 PORT WITH XVF4

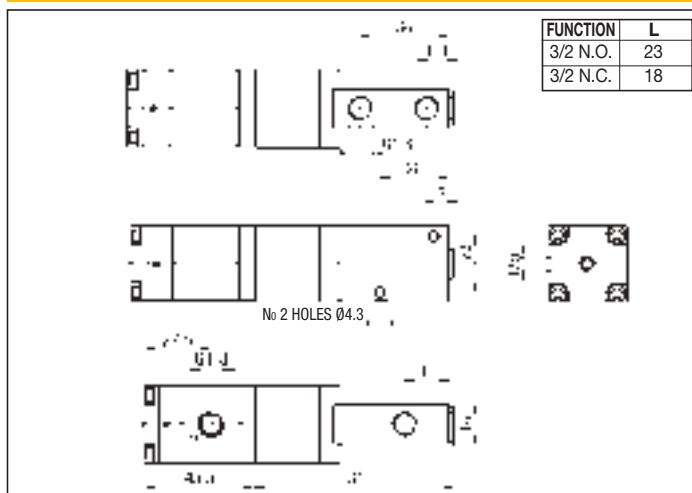

5 PORT WITH ULCSV/R

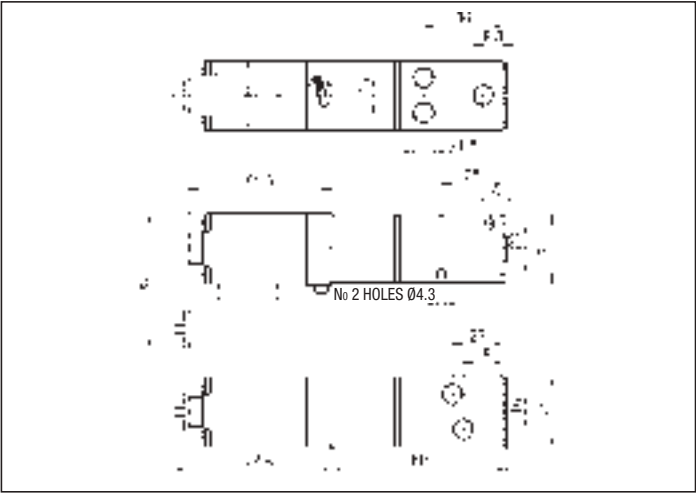

5 PORT WITH C/USCSVG

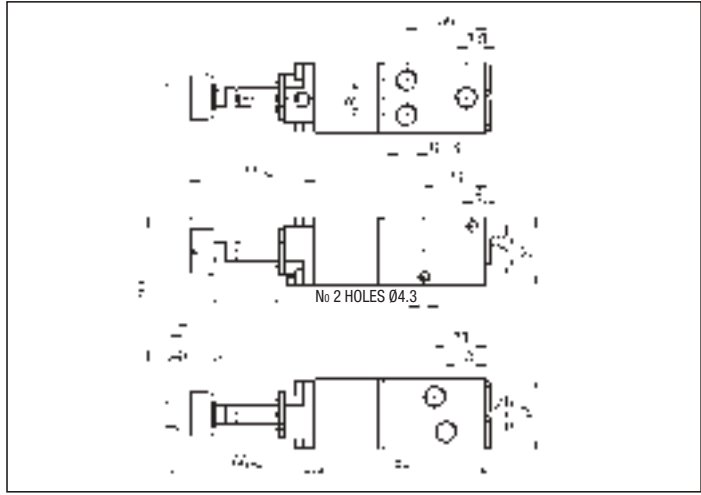

5 PORT WITH XVF4

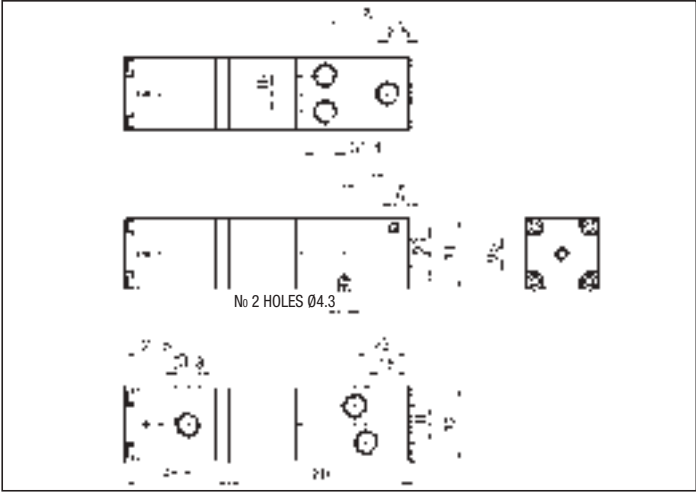

FIXED LENGTH BASE FOR MANIFOLD MOUNTING OF VALVES G 1/8 - CK8

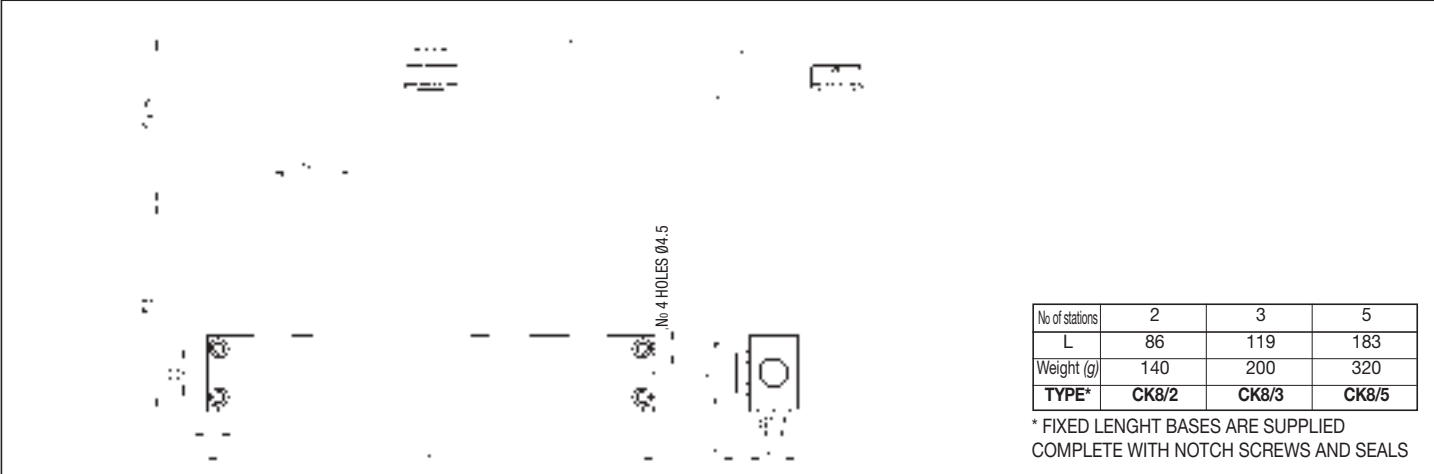

No of stations	2	3	5
L	86	119	183
Weight (g)	140	200	320
TYPE*	CK8/2	CK8/3	CK8/5

* FIXED LENGTH BASES ARE SUPPLIED COMPLETE WITH NOTCH SCREWS AND SEALS

2

PILOT ACTUATED VALVES G 1/4 - 2, 3 and 5 PORT

Symbol	Function	Controls		Response time at 6 bar (ms)		Flow rate at 6 bar $\Delta P = 1 \text{ bar (Nl/min)}$	Weight (g)	TYPE*
		Pilot	Return	Energized	De-energized			
	3/2 N.O. monostable	Small pneumatic	Mechanical spring	20	30	950	225	UKA 4/16
	3/2 N.C. monostable	Small pneumatic	Mechanical spring	20	30	1100	225	UKC 4/16
		Servo fed small pneumatic	Mechanical spring	16	30	1100	225	UKC 4/16/SA
	3/2 N.O. monostable	Big pneumatic	Mechanical spring	20	30	950	280	UKA 4/32
	3/2 N.C. monostable	Big pneumatic	Mechanical spring	20	30	1100	280	UKC 4/32
		Servo fed big pneumatic	Mechanical spring	20	28	1100	280	UKC 4/32/SA
	5/2 monostable	Pneumatic	Mechanical spring	24	45	1000	415	UKCA 4
		Servo fed pneumatic	Mechanical spring	24	45	1000	415	UKCA 4/SA

*/EX Consistent with the ATEX directive II 2GD c T5 T100°C -20°C ≤ Ta ≤ 60°C E.G.: **UKCA4/EX**

PS.: ADD AT THE TYPE OF THE VALVES 3/2 THE LETTER "H" BETWEEN THE LETTERS "K" AND "A" (OR "C") TO ORDER 2/2 N.O. (OR 2/2 N.C.) VALVES.

E.G.: **UKHA 4/16; UKHC 4/32**

3 PORT SMALL PNEUMATIC

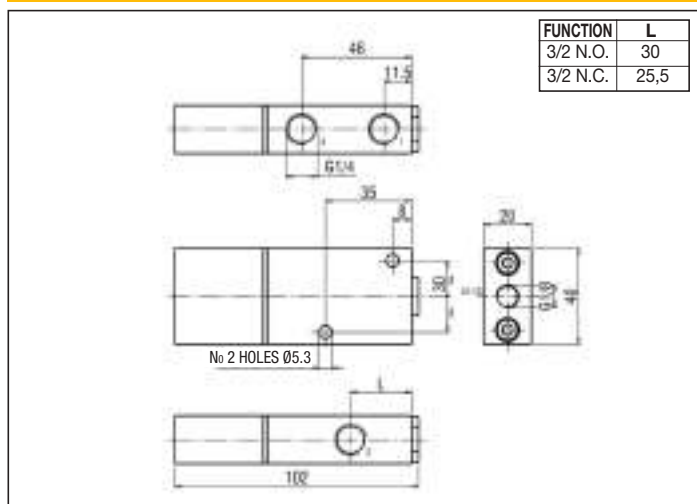

3 PORT BIG PNEUMATIC

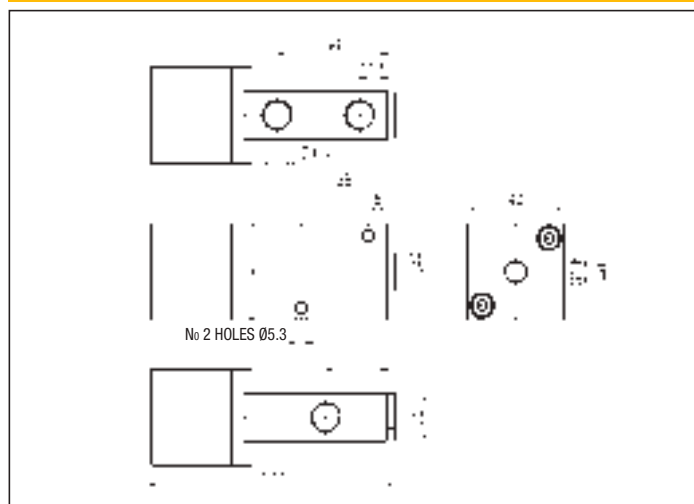

5 PORT

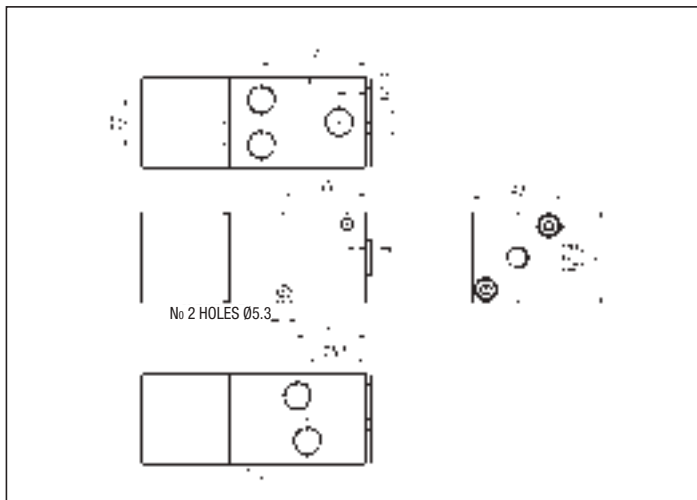

3 PORT WITH XVF4

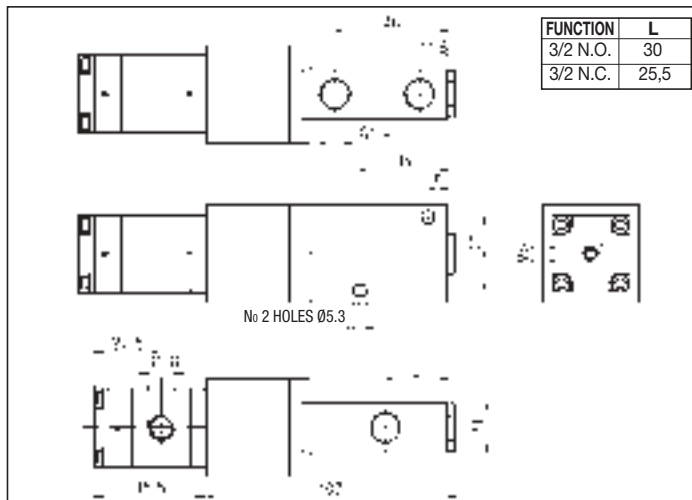

2

SOLENOID ACTUATED VALVES G 1/4 - 2, 3 and 5 PORT

Symbol	Function	Controls		Response time at 6 bar (ms)		Flow rate at 6 bar ΔP = 1 bar (Nl/min)	Weight (g)	TYPE*
		Pilot	Return	Energized	De-energized			
	3/2 N.O. monostable	Small solenoid	Mechanical spring	10	28	950	225	UKA 4/16/U**
	3/2 N.C. monostable	Small solenoid	Mechanical spring	10	28	1100	230	UKC 4/16/U**
	3/2 N.O. monostable	Big solenoid	Mechanical spring	20	30	950	280	UKA 4/32/U***
	3/2 N.C. monostable	Big solenoid	Mechanical spring	20	30	1100	280	UKC 4/32/U***
	5/2 monostable	Solenoid	Mechanical spring	24	45	1000	415	UKCA 4/U***

*/EX Consistent with the ATEX directive 2014/52/EU II 2GD c T5 T100°C -20°C ≤ Ta ≤ 60°C ES.: UKCA4/U/EX

/EX Consistent with the ATEX directive 2014/52/EU III 3G c Ex nA IIC T5 Gc -5°C ≤ Ta ≤ 50°C II 3D c Ex tc IIIC T100°C IP65 Dc

ES.: UKA4/16/U2400/EX

** TYPES OF THESE SOLENOID VALVES INCLUDE THE PILOTING SOLENOID VALVES "UMCSV" - SEE ON PAGE 2.5 (SPECIFY THE VOLTAGE IN THE ORDER)

*** TYPES OF THESE SOLENOID VALVES DO NOT INCLUDE THE PILOTING SOLENOID VALVES (SEE ON PAGE 2.9 FOR "ULCSV/R" AND ON PAGE 2.16 FOR "C/USCSVG") WHEREAS USING AS PILOT THE VALVE "XVF4" THE RESULT IS A LOW PRESSURE PILOT ACTUATED VALVE (FOR "XVF4" - SEE ON PAGE 3.37)

P.S.: ADD AT THE TYPE OF THE VALVES 3/2 THE LETTER "H" BETWEEN THE LETTERS "K" AND "A" (OR "C") TO ORDER 2/2 N.O. (OR 2/2 N.C.) VALVES. E.G.: UKHA 4/16/U; UKHC 4/32/U

3 PORT SMALL SOLENOID

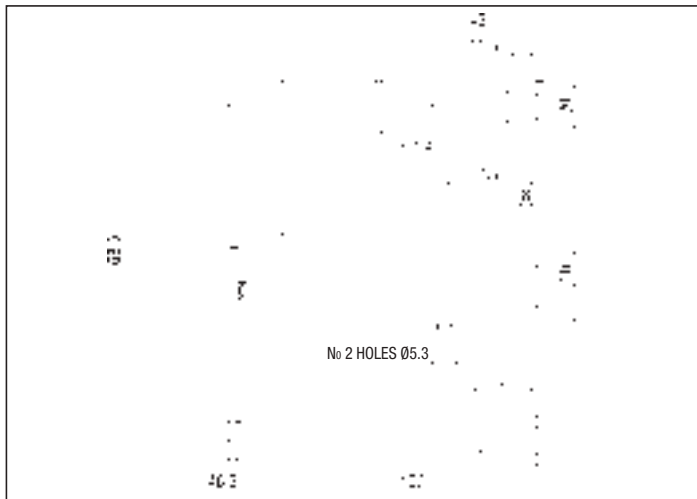

3 PORT BIG SOLENOID WITH ULCSV/R

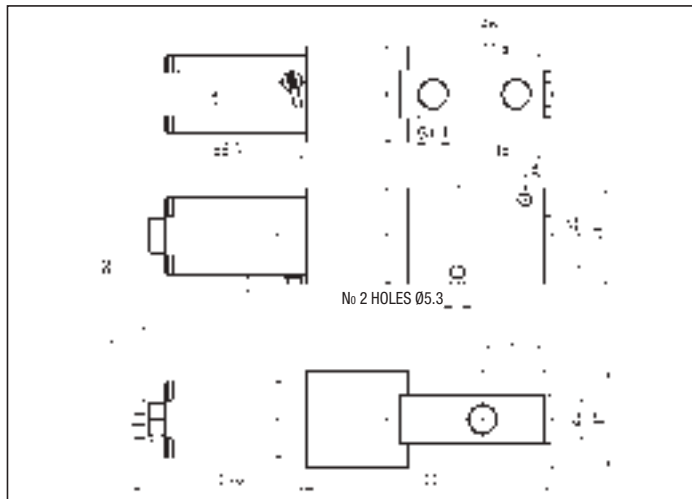

2

3 PORT BIG SOLENOID WITH C/USCSVG

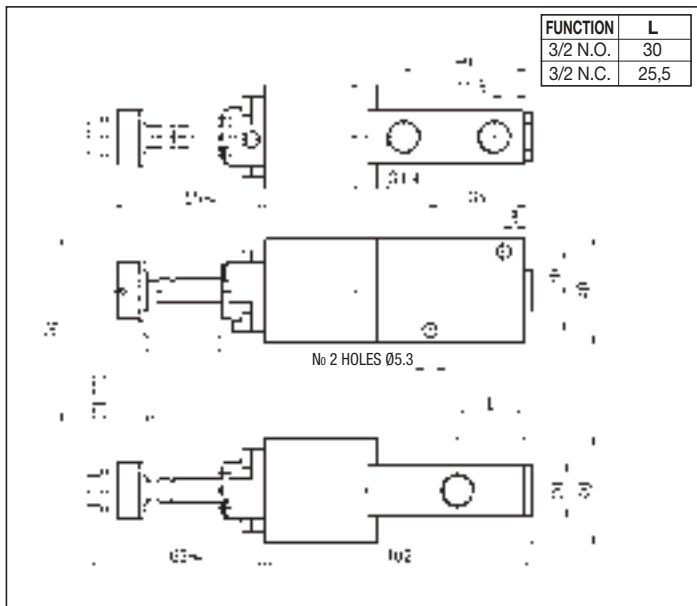

5 PORT WITH ULCSV/R

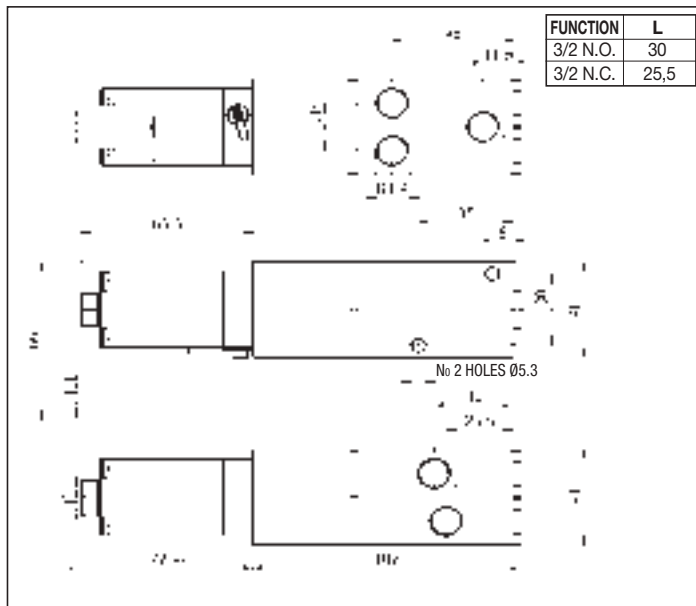

5 PORT WITH C/USCSVG

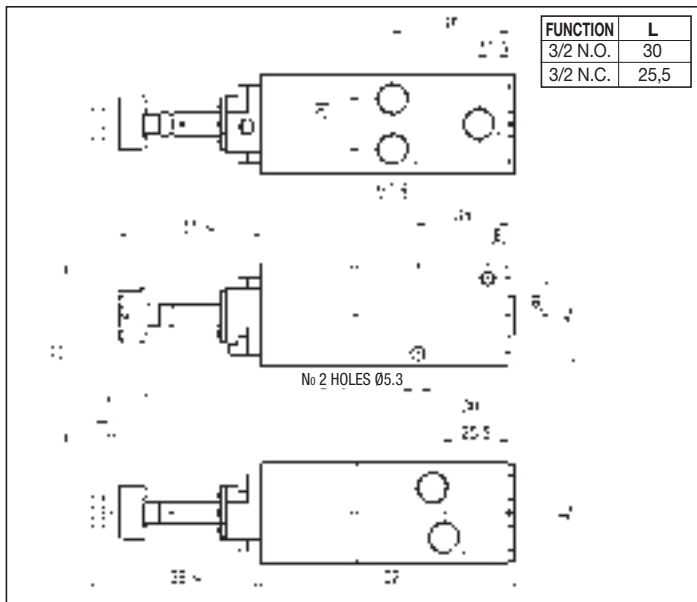

5 PORT WITH XVF4

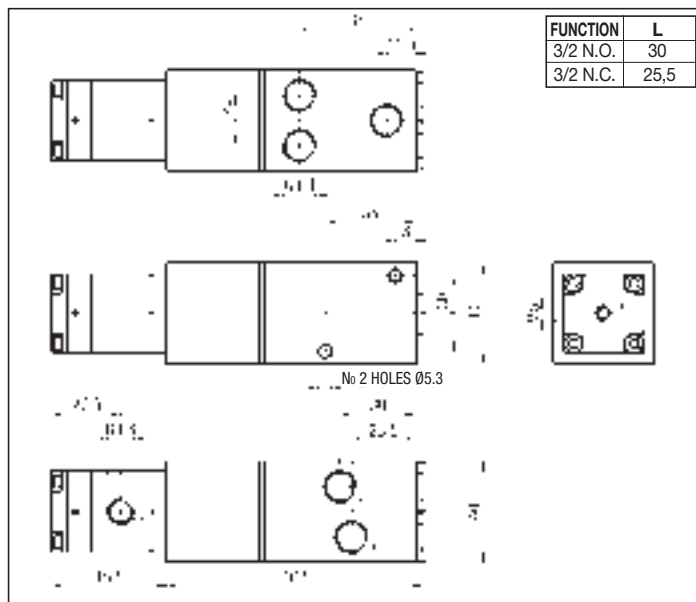

FIXED LENGTH BASE FOR MANIFOLD MOUNTING OF VALVES G 1/4 - CK4

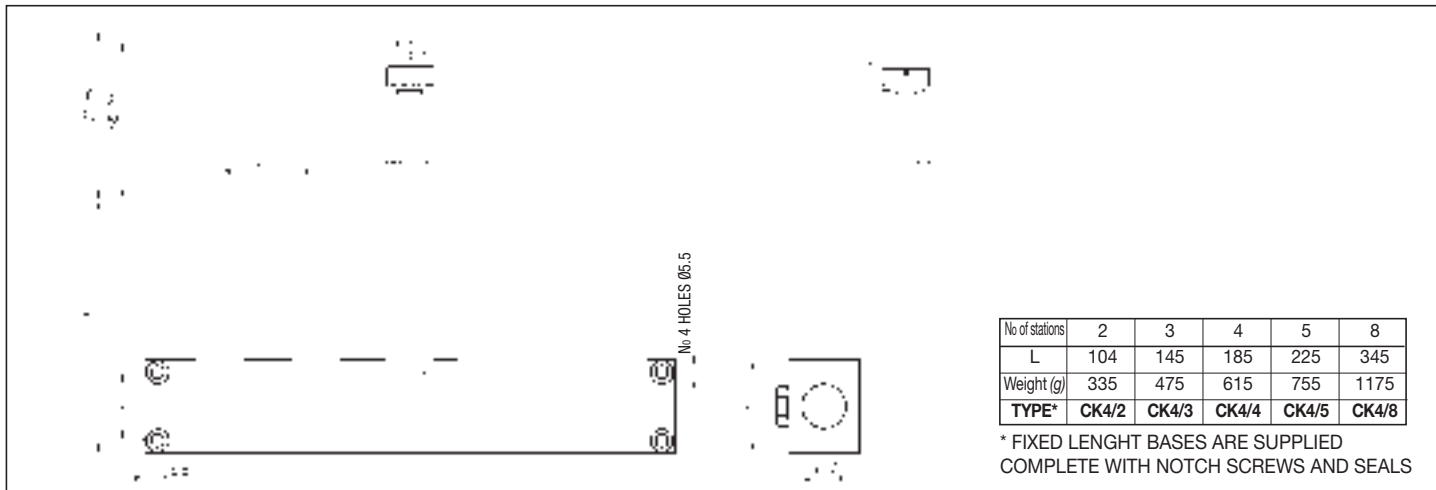

PILOT ACTUATED VALVES G 1/2 - 2, 3 and 5 PORT

Symbol	Function	Controls		Response time at 6 bar (ms)		Flow rate at 6 bar $\Delta P = 1$ bar (Nl/min)	Weight (g)	TYPE*
		Pilot	Return	Energized	De-energized			
	3/2 N.O. monostable	Small pneumatic	Mechanical spring	24	32	1900	420	UKA 2/20
	3/2 N.C. monostable	Small pneumatic	Mechanical spring	24	32	2100	420	UKC 2/20
		Servo fed small pneumatic	Mechanical spring	25	32	2100	520	UKC 2/20/SA
	3/2 N.O. monostable	Big pneumatic	Mechanical spring	24	32	1900	520	UKA 2/40
	3/2 N.C. monostable	Big pneumatic	Mechanical spring	24	32	2100	520	UKC 2/40
		Servo fed big pneumatic	Mechanical spring	20	30	2100	520	UKC 2/40/SA
	5/2 monostable	Pneumatic	Mechanical spring	24	40	2000	800	UKCA 2
		Servo fed pneumatic	Mechanical spring	24	40	2000	800	UKCA 2/SA

*/EX Consistent with the ATEX directive II 2GD c T5 T100°C -20°C≤Ta≤60°C E.G.: **UKCA2/EX**

PS.: ADD AT THE TYPE OF THE VALVES 3/2 THE LETTER "H" BETWEEN THE LETTERS "K" AND "A" (OR "C") TO ORDER 2/2 N.O. (OR 2/2 N.C.) VALVES.

E.G.: **UKHA 2/20; UKHC 2/20**

3 PORT SMALL PNEUMATIC

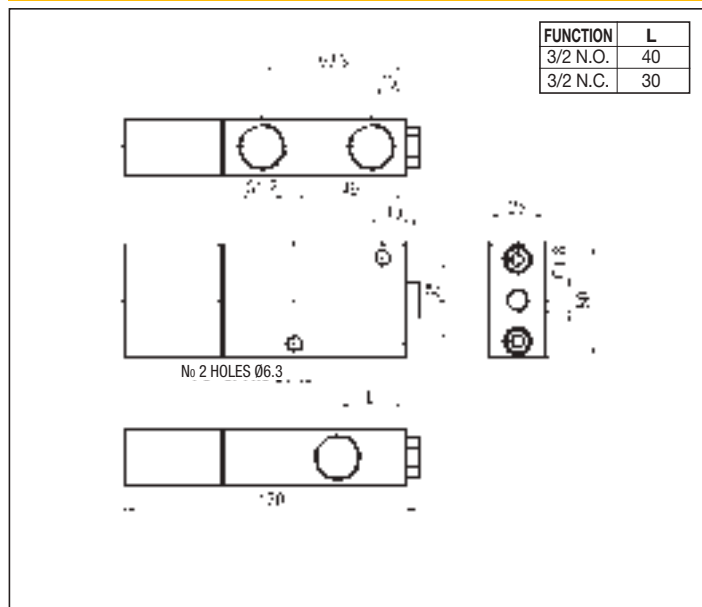

3 PORT BIG PNEUMATIC

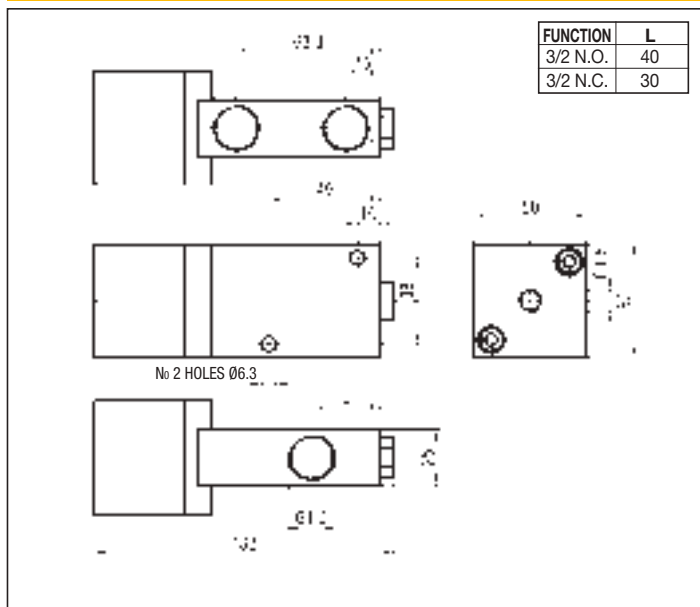

2

5 PORT

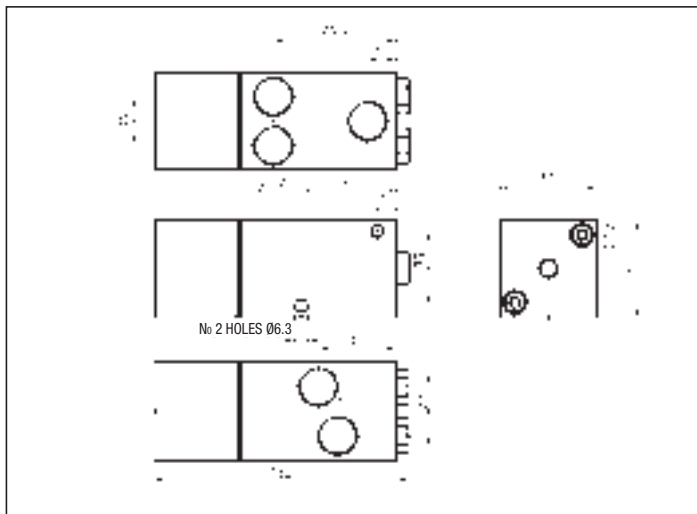

3 PORT WITH XVF4

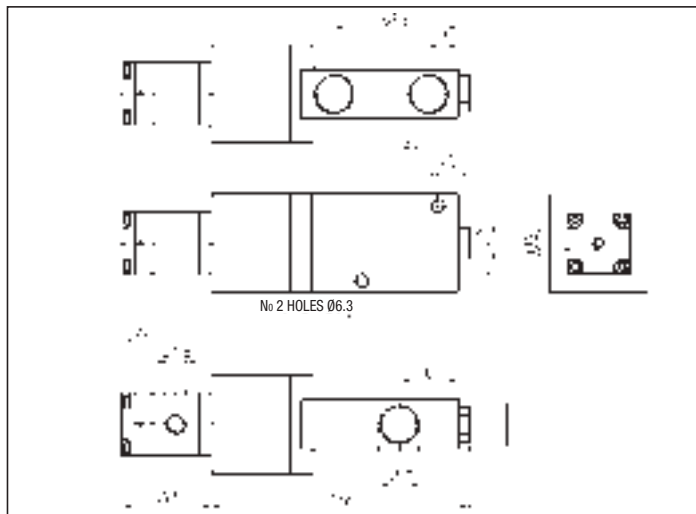

SOLENOID ACTUATED VALVES G 1/2 - 2, 3 and 5 PORT

Symbol	Function	Controls		Response time at 6 bar (ms)		Flow rate at 6 bar ΔP = 1 bar (Nl/min)	Weight (g)	TYPE*
		Pilot	Return	Energized	De-energized			
	3/2 N.O. monostable	Small solenoid	Mechanical spring	24	32	1900	430	UKA 2/20/U**
	3/2 N.C. monostable	Small solenoid	Mechanical spring	24	32	2100	440	UKC 2/20/U**
	3/2 N.O. monostable	Big solenoid	Mechanical spring	24	32	1900	530	UKA 2/40/U***
	3/2 N.C. monostable	Big solenoid	Mechanical spring	24	32	2100	540	UKC 2/40/U***
	5/2 monostable	Solenoid	Mechanical spring	24	32	2000	810	UKCA 2/U***

* /EX Consistent with the ATEX directive II 2GD c T5 T100°C -20°C ≤ Ta ≤ 60°C ES.: UKCA2/U/EX * /EX Consistent with the ATEX directive II 3G c Ex nA IIC T5 Gc -5°C ≤ Ta ≤ 50°C E.G.: UKA2/20/U2400/EX II 3D c Ex tc IIC T100°C IP65 Dc

** TYPES OF THESE SOLENOID VALVES INCLUDE THE PILOTING SOLENOID VALVES "UMCSV" - SEE ON PAGE 2.5 (SPECIFY THE VOLTAGE IN THE ORDER)

*** TYPES OF THESE SOLENOID VALVES DO NOT INCLUDE THE PILOTING SOLENOID VALVES (SEE ON PAGE 2.9 FOR "ULCSV/R" AND ON PAGE 2.13 FOR "C/USCSVG") WHEREAS USING AS PILOT THE VALVE "XVF4" THE RESULT IS A LOW PRESSURE PILOT ACTUATED VALVE (FOR "XVF4" - SEE ON PAGE 3.37)

P.S.: ADD AT THE TYPE OF THE VALVES 3/2 THE LETTER "H" BETWEEN THE LETTERS "K" AND "A" (OR "C") TO ORDER 2/2 N.O. (OR 2/2 N.C.) VALVES.

E.G.: UKHA 2/20; UKHC 2/20

3 PORT SMALL SOLENOID WITH UMCSV

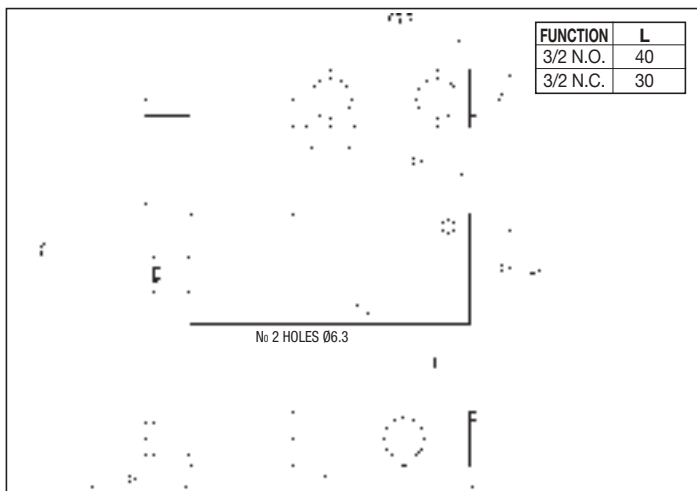

3 PORT BIG SOLENOID WITH ULCSV/R

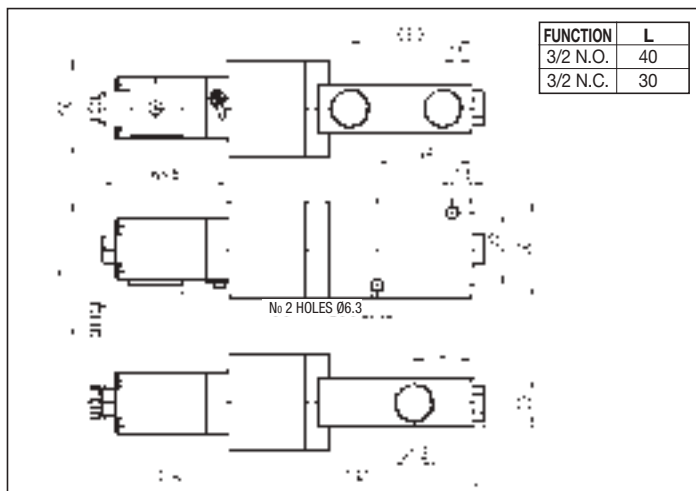

3 PORT BIG SOLENOID WITH C/USCSVG

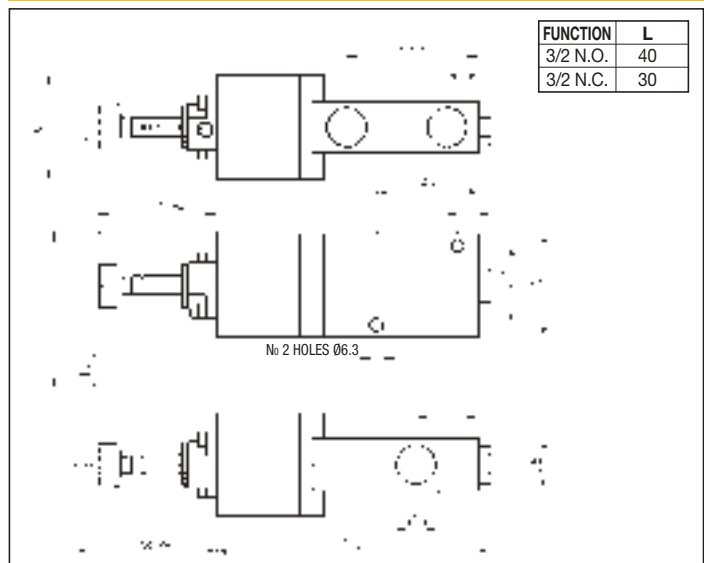

5 PORT WITH ULCSV/R

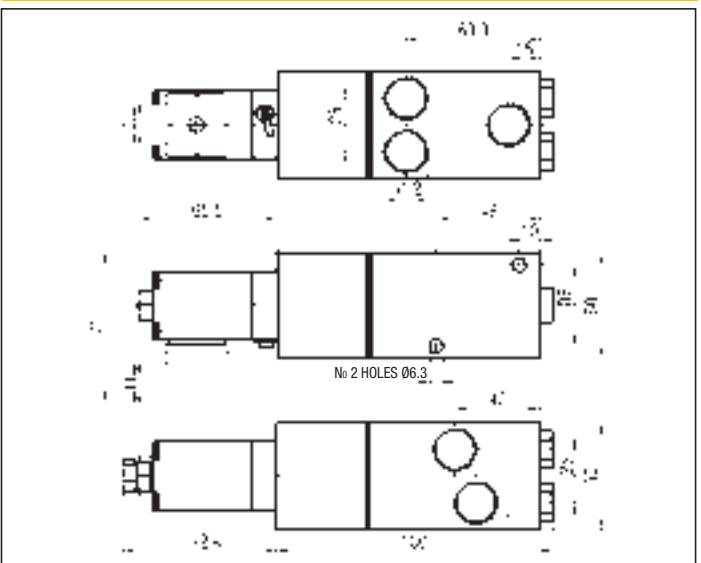

5 PORT WITH C/USCSVG

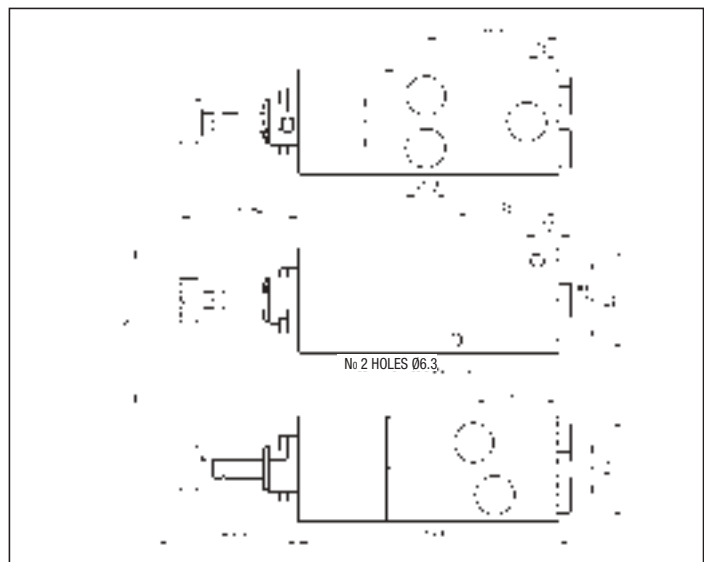

5 PORT WITH XVF4

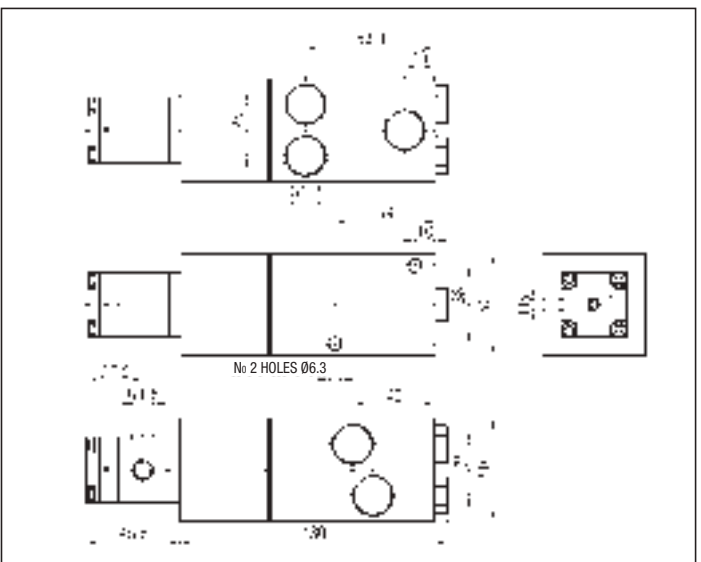

FIXED LENGTH BASE FOR MANIFOLD MOUNTING OF VALVES G 1/2 - CK2

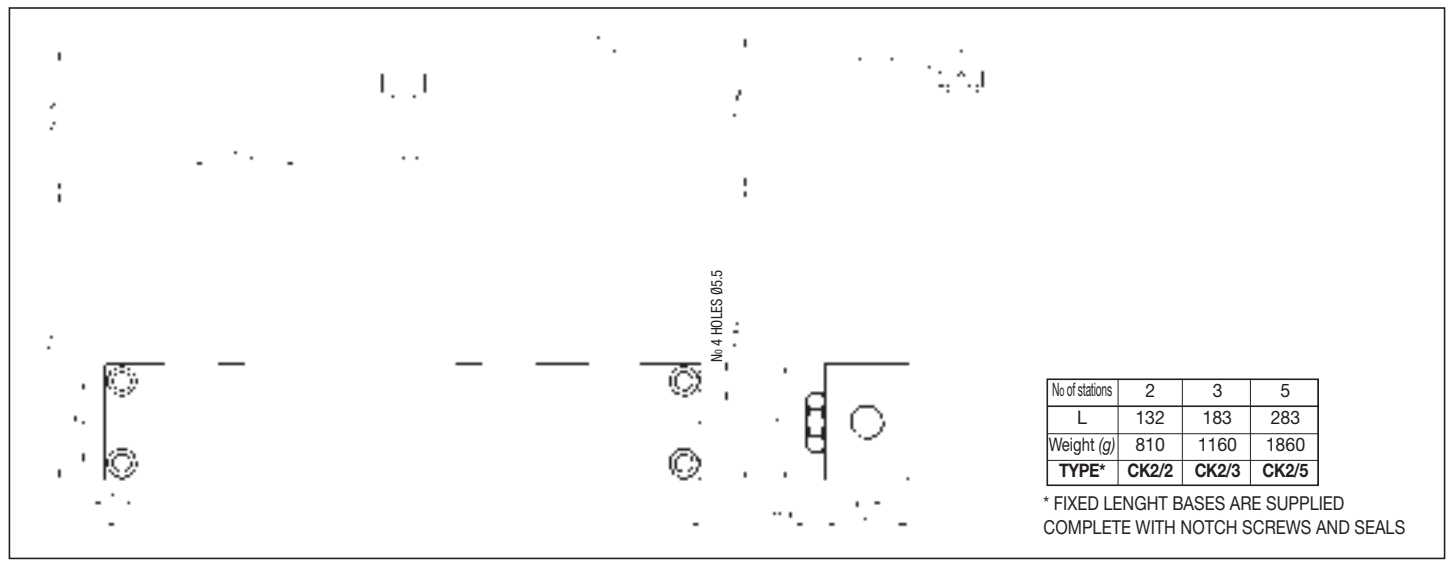

2

PILOT ACTUATED VALVES G 1 - 2, 3 and 5 PORT

Symbol	Function	Controls		Response time at 6 bar (ms)		Flow rate at 6 bar $\Delta P = 1$ bar (Nl/min)	Weight (g)	TYPE*
		Pilot	Return	Energized	De-energized			
	3/2 N.O. monostable	Small pneumatic	Mechanical spring	40	65	11300	2550	UKA 1
	3/2 N.C. monostable	Small pneumatic	Mechanical spring	40	65	7800	2550	UKC 1
	5/2 monostable	Pneumatic	Mechanical spring	40	70	8050	5160	UKCA 1

*EX Consistent with the ATEX directive II 2GD c T5 T100°C -20°C ≤ Ta ≤ 60°C E.G.: **UKCA1/EX**

PS.: ADD AT THE TYPE OF THE VALVES 3/2 THE LETTER "H" BETWEEN THE LETTERS "K" AND "A" (OR "C") TO ORDER 2/2 N.O. (OR 2/2 N.C.) VALVES.
E.G.: **UKHA 1; UKHC 1**

UKA 1 - UKC 1

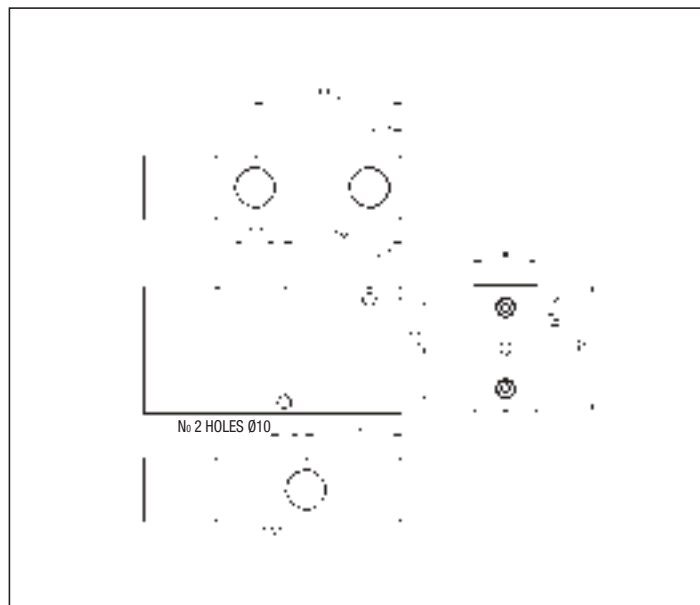

UKCA 1

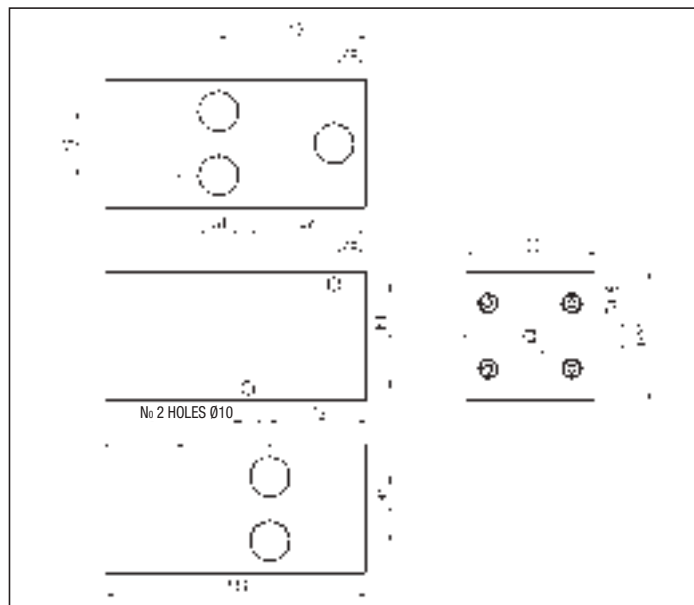

3 PORT WITH XVF4

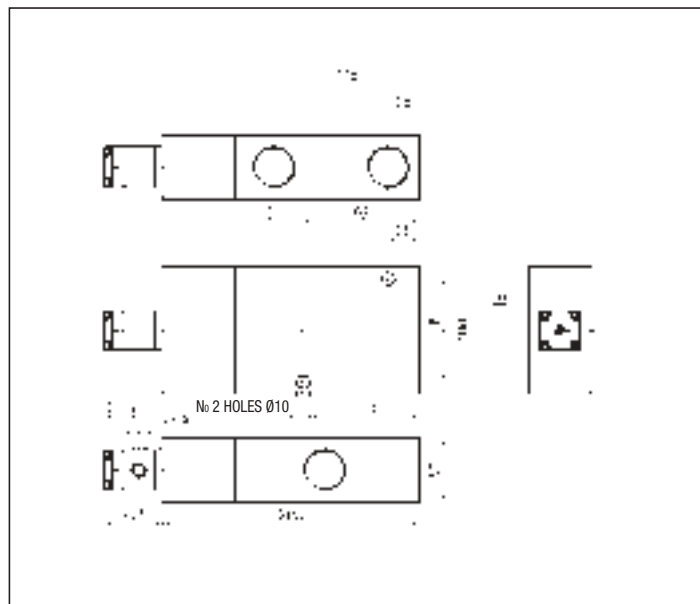

5 PORT WITH XVF4

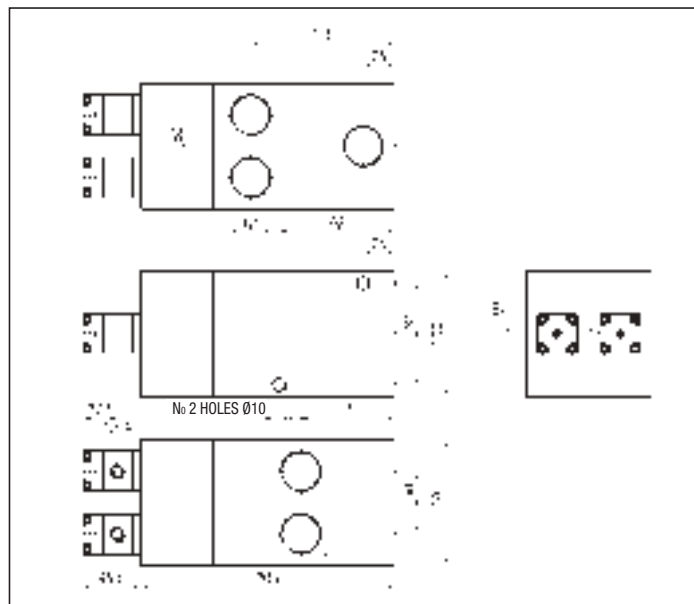

SOLENOID ACTUATED VALVES G 1 - 2, 3 and 5 PORT

Symbol	Function	Controls		Response time at 6 bar (ms)		Flow rate at 6 bar $\Delta P = 1$ bar (l/min)	Weight (g)	TYPE*
		Pilot	Return	Energized	De-energized			
	3/2 N.O. monostable	Small solenoid	Mechanical spring	40	65	11300	2600	UKA 1/U**
	3/2 N.C. monostable	Small solenoid	Mechanical spring	40	65	7800	2550	UKC 1/U**
	5/2 monostable	Solenoid	Mechanical spring	40	70	8050	5100	UKCA 1/U**

*EX Consistent with the ATEX directive II 2GD c T5 T100°C -20°C ≤ T_a ≤ 60°C E.G.: **UKCA1/U/EX**

** THE TYPES OF THE SOLENOID VALVES DO NOT INCLUDE THE PILOTING SOLENOID VALVES (SEE ON PAGE 2.6 FOR "ULCSV/R" AND ON PAGE 2.16 FOR "C/USCSVG") WHEREAS USING AS PILOT THE VALVE "XVF4" THE RESULT IS A LOW PRESSURE PILOT ACTUATED VALVE (FOR "XVF4" - SEE ON PAGE 3.37) P.S.: ADD AT THE TYPE OF THE VALVES 3/2 THE LETTER "H" BETWEEN THE LETTERS "K" AND "A" (OR "C") TO ORDER 2/2 N.O. (OR 2/2 N.C.) VALVES. E.G.: **UKHA 1/U; UKHC 1/U**

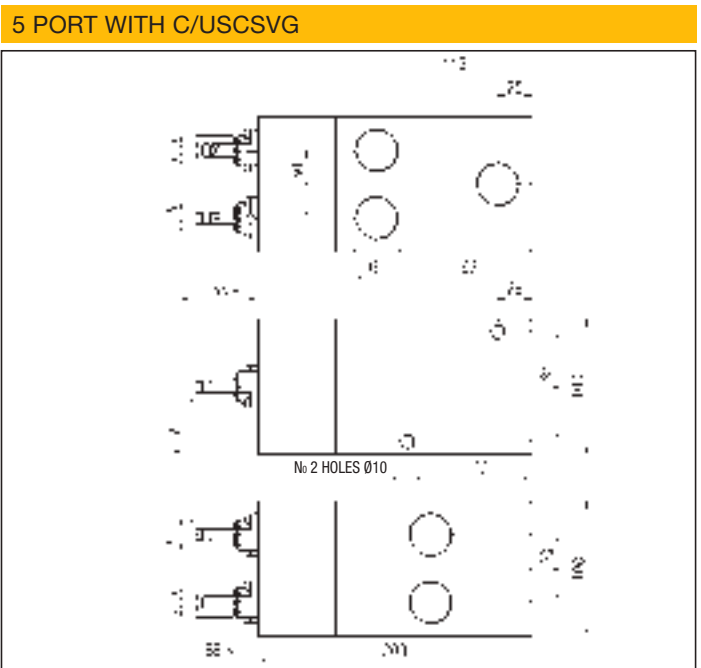
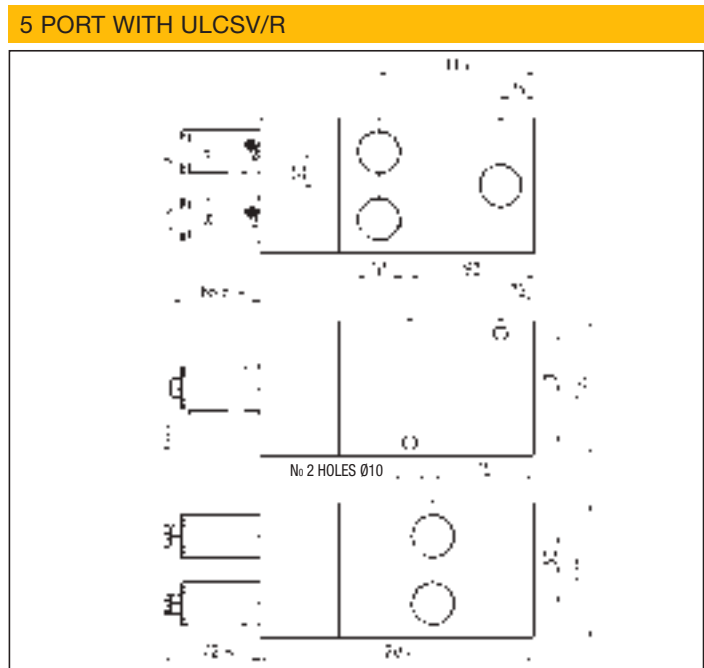
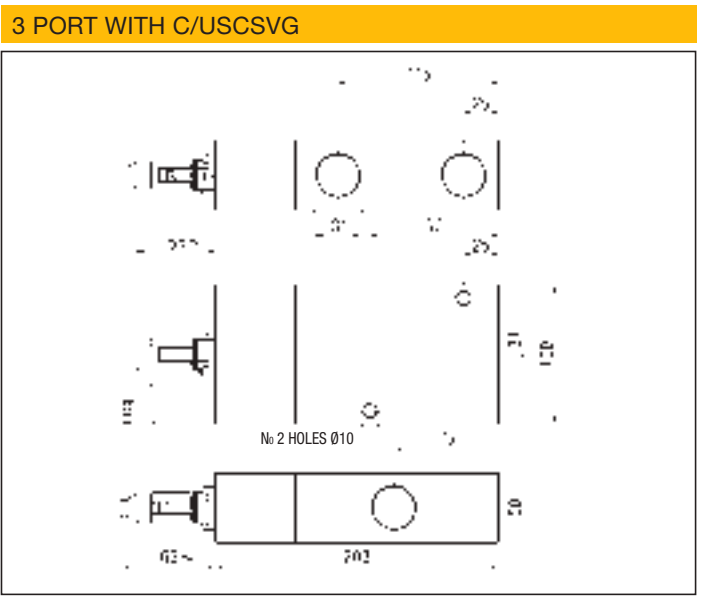
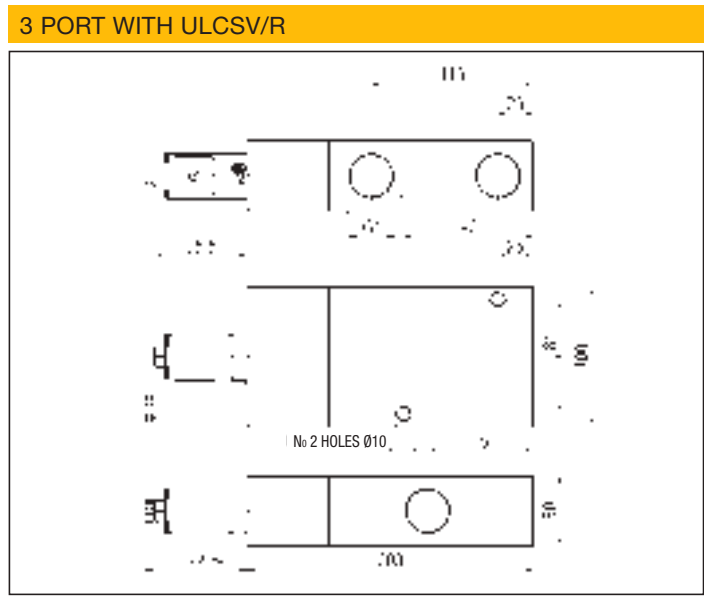

series UDS ISO

Valves to ISO 5599/1 standard
pilot and solenoid actuated
sizes 1 - 2 - 3

DESCRIPTION

Valves series "UDS ISO" are produced in the 5/2 and 5/3 pneumatic functions according to the interface to ISO 5599/1 standard and they are mounted onto single or manifold bases, bottom or side ported. The ex CNOMO solenoid valve, with manual override (screwdriver type C/UECSVB or button type C/UECSPB), in the solenoid actuated version is mounted with coil type USBG side 30 mm (that allows a greater yield) or type USB side 22 mm and can be supplied in compliance with ATEX directive, category 2GD.



2

TECHNICAL DATA

Operating pressure	Monostable 2 ÷ 10 bar (2,5 ÷ 10 bar for ISO 2) Bistable 1,5 ÷ 10 bar
Working temperature	0 ÷ +50 °C (-20 °C with dry air)
Fluid	Compressed air, filtered, continuous lubricated, unlubricated or dry lubricated
Port size	Interface to ISO 5599/1
Pneumatic piloting port size	Interface to ISO 5599/1
Piloting solenoid valves	C/UECSVB - C/UECSPB - see chapter direct acting solenoid valves series ex CNOMO on page 2.15
Coils	USBG - see chapter coils on page 2.17 USBG2 - see chapter coils on page 2.17 USB - see chapter coils on page 2.17
Electric connectors	ULR1B - see chapter connectors on page 2.18 USR102/N9 - see chapter connectors on page 2.18

MATERIALS

Bottoms	Size 1 - 2: Techno-polymer Size 3: Aluminium alloy
Body	Size 1 - 2: Techno-polymer Size 3: Aluminium alloy
Distance rings	Acetal resin
Springs	Galvanized steel
Seals	NBR rubber + steel insert
Spool	Aluminium alloy
Piston	Aluminium alloy

SPARE PARTS

SEALS KIT	
Size 1	UDS/SG/105
Size 2	UDS/SG/212
Size 3	UDSI/SG/3

FLOW CHART SIZE 1

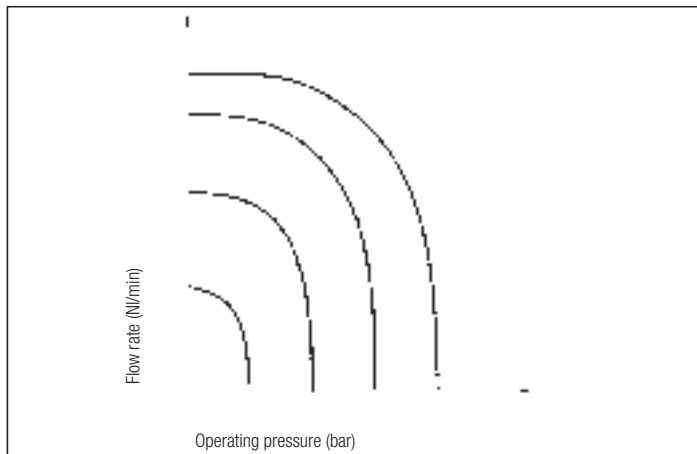

PILOTING CHART SIZE 1

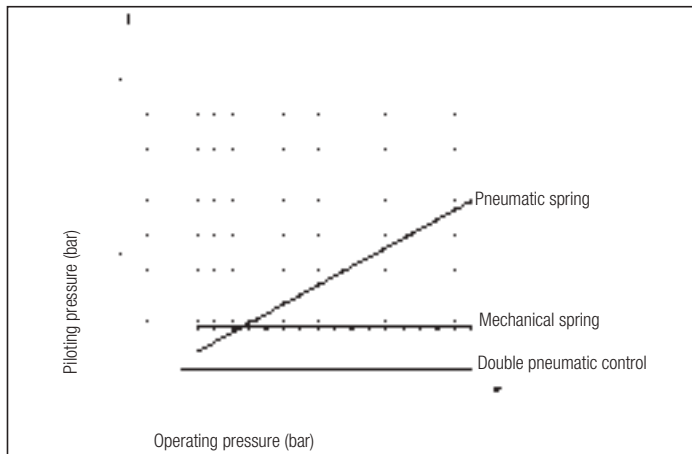

FLOW CHART SIZE 2

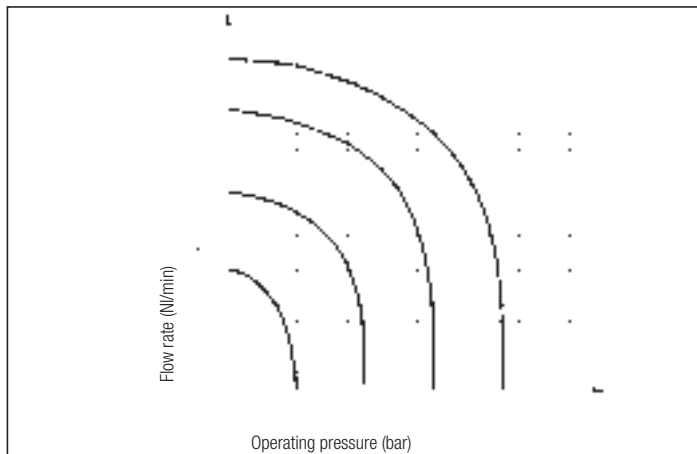

PILOTING CHART SIZE 2

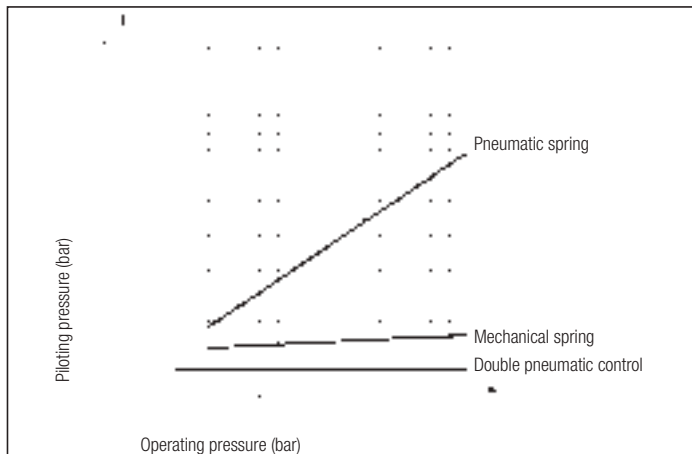

FLOW CHART SIZE 3

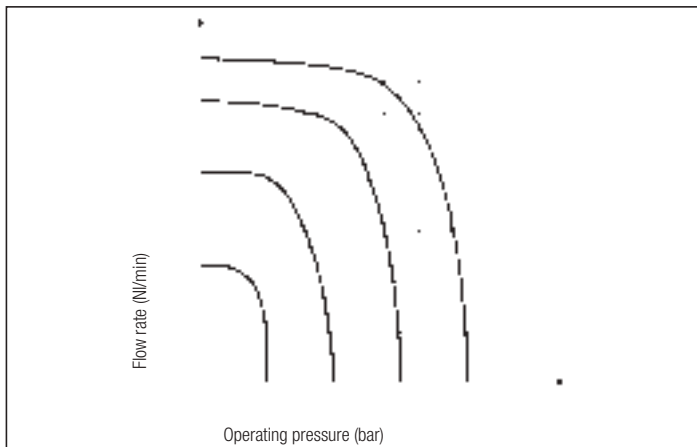

PILOTING CHART SIZE 3

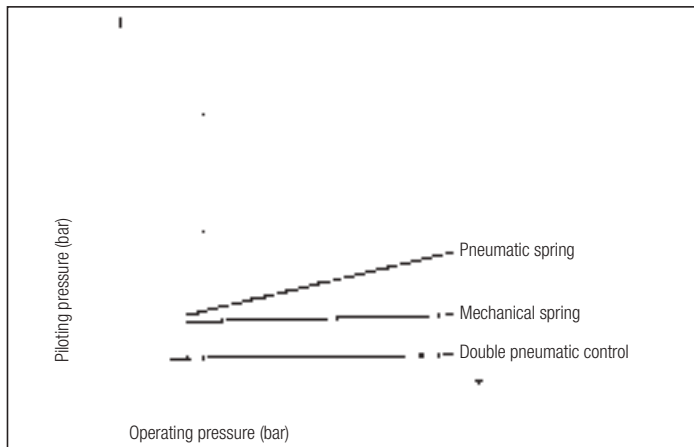

PILOT ACTUATED VALVES SIZE 1

Symbol	Function	Controls		Response time at 6 bar (ms)		Flow rate at 6 bar $\Delta P = 1$ bar (Nl/min)	Weight (g)	TYPE*
		Pilot	Return	Energized	De-energized			
	5/2 monostable	Pneumatic	Mechanical spring	20	30	960	230	UDS 105 KR/ZR
		Pneumatic	Pneumatic spring	20	14	960	230	UDS 105 KR/TQ
	5/2 bistable	Pneumatic	Pneumatic	15	15	960	230	UDS 105 KR/KR
	5/2 bistable with override on body valve	Pneumatic	Pneumatic	15	15	960	250	UDS 105 KRP/KRP
	5/2 bistable	Big pneumatic	Small pneumatic	15	20	960	230	UDS 105 KR/TR
	5/3 closed centre	Pneumatic	Mechanical spring	20	25	580	275	UDS 105 SR/SR
	5/3 open centre	Pneumatic	Mechanical spring	20	25	800	275	UDS 105 AR/AR
	5/3 pressure centre	Pneumatic	Mechanical spring	20	25	1100	275	UDS 105 PR/PR

*EX Consistent with the ATEX directive II 2GD c T5 T100°C -20°C ≤ Ta ≤ 50°C

ES.: UDS 105 KR/ZR/EX

5 PORT SIZE 1



5 PORT SIZE 1 WITH MANUAL OVERRIDE ON BODY VALVE

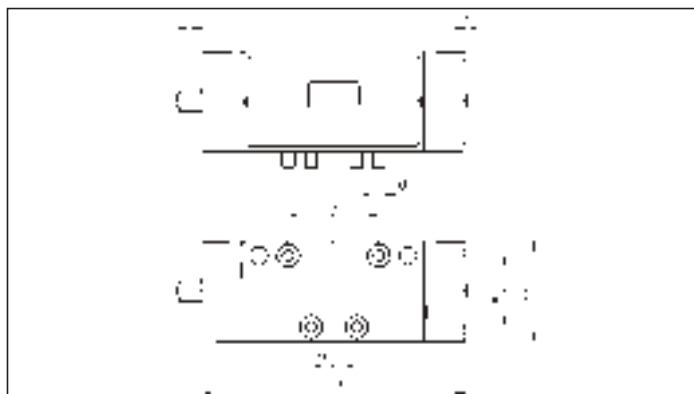

2

SOLENOID ACTUATED VALVES SIZE 1

Symbol	Function	Controls		Response time at 6 bar (ms)		Flow rate at 6 bar $\Delta P = 1 \text{ bar (Nl/min)}$	Weight (g)	TYPE*
		Pilot	Return	Energized	De-energized			
	5/2 monostable	Solenoid	Mechanical spring	20	30	960	305	UDS 105 KUEC/ZR
		Solenoid	Pneumatic spring	20	30	960	305	UDS 105 KUEC/TQ
		Solenoid pilot assisted	Mechanical spring	20	30	960	305	UDS 105 KUER/ZR
	5/2 bistable	Solenoid	Small pneumatic	20	25	960	310	UDS 105 KUEC/TR
		Solenoid pilot assisted	Small pneumatic	20	25	960	310	UDS 105 KUER/TR
		Solenoid	Solenoid	15	15	960	375	UDS 105 KUEC/KUEC
		Solenoid pilot assisted	Solenoid pilot assisted	15	15	960	375	UDS 105 KUER/KUER
	5/3 closed centre	Solenoid	Mechanical spring	20	25	580	425	UDS 105 SUEC/SUEC
		Solenoid pilot assisted	Mechanical spring	20	25	580	425	UDS 105 SUER/SUER
	5/3 open centre	Solenoid	Mechanical spring	20	25	800	425	UDS 105 AUEC/AUEC
		Solenoid pilot assisted	Mechanical spring	20	25	800	425	UDS 105 AUER/AUER
	5/3 pressure centre	Solenoid	Mechanical spring	20	25	1100	425	UDS 105 PUEC/PUEC
		Solenoid pilot assisted	Mechanical spring	20	25	1100	425	UDS 105 PUER/PUER

*EX Consistent with the ATEX directive II 2GD c T5 T100°C -20°C ≤ Ta ≤ 50°C E.G.: **UDS 105 KUEC/TQ/EX**

THE TYPES OF THE SOLENOID VALVES DO NOT INCLUDE COILS

P.S.: SUBSTITUTE THE LETTER "E" WITH THE LETTER "P" IN EACH SOLENOID CONTROL TYPE TO ORDER THE SOLENOID ACTUATED VALVES TO ISO STANDARD WITH MANUAL OVERRIDE (MONOSTABLE BUTTON) ON THE PILOTING SOLENOID VALVES, E.G.: **UDS 105 KUEC/TR** BECOMES **UDS 105 KUPC/TR** - **UDS 105 KUEC/KUEC** BECOMES **UDS 105 KUPC/KUPC**

5 PORT SIZE 1 MONOSTABLE

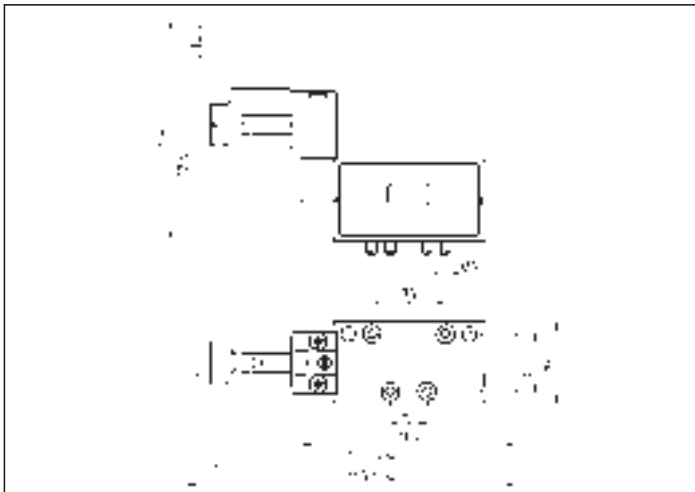

5 PORT SIZE 1 BISTABLE AND 3 POSITIONS

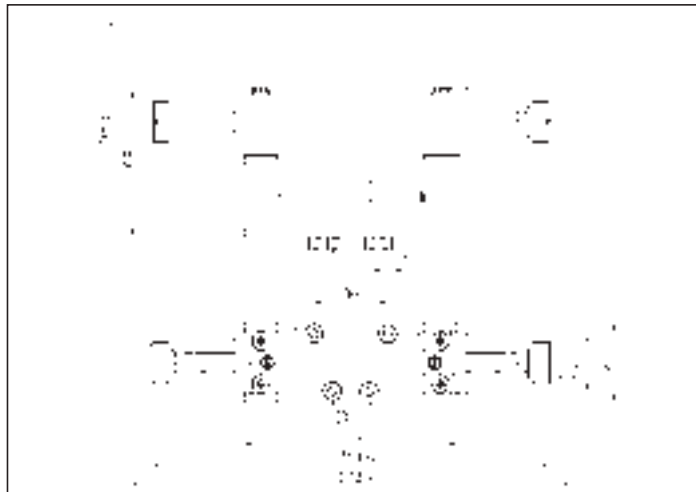

PILOT ACTUATED VALVES SIZE 2

Symbol	Function	Controls		Response time at 6 bar (ms)		Flow rate at 6 bar $\Delta P = 1$ bar (Nl/min)	Weight (g)	TYPE*
		Pilot	Return	Energized	De-energized			
	5/2 monostable	Pneumatic	Mechanical spring	47	50	1500	515	UDS 212 KR/ZR
		Pneumatic	Pneumatic spring	47	50	1500	510	UDS 212 KR/TQ
	5/2 bistable	Pneumatic	Pneumatic	23	23	1500	515	UDS 212 KR/KR
		Big pneumatic	Small pneumatic	20	40	1500	515	UDS 212 KR/TR
	5/3 closed centre	Pneumatic	Mechanical spring	30	35	1000	580	UDS 212 SR/SR
	5/3 open centre	Pneumatic	Mechanical spring	30	35	1200	580	UDS 212 AR/AR
	5/3 pressure centre	Pneumatic	Mechanical spring	30	35	1300	580	UDS 212 PR/PR

*/EX Consistent with the ATEX directive II 2GD c T5 T100°C -20°C ≤ Ta ≤ 50°C E.G.: UDS 212 KR/ZR/EX

5 PORT SIZE 2

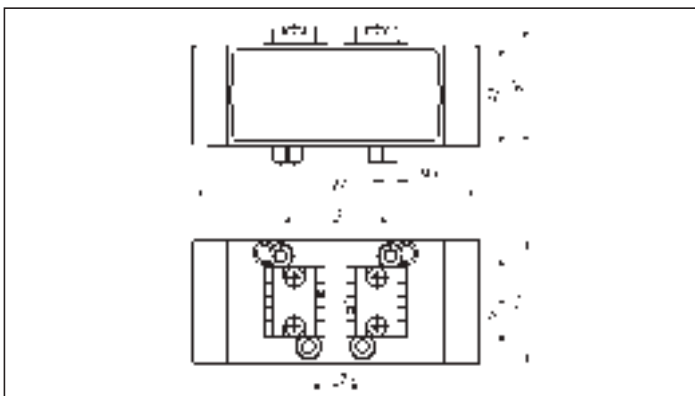

2

SOLENOID ACTUATED VALVES SIZE 2

Symbol	Function	Controls		Response time at 6 bar (ms)		Flow rate at 6 bar $\Delta P = 1 \text{ bar (Nl/min)}$	Weight (g)	TYPE*
		Pilot	Return	Energized	De-energized			
	5/2 monostable	Solenoid	Mechanical spring	40	45	1500	580	UDS 212 KUEC/ZR
		Solenoid	Pneumatic spring	47	50	1500	580	UDS 212 KUEC/TQ
		Solenoid pilot assisted	Mechanical spring	40	45	1500	580	UDS 212 KUER/ZR
	5/2 bistable	Solenoid	Small pneumatic	40	45	1500	580	UDS 212 KUEC/TR
		Solenoid pilot assisted	Small pneumatic	40	45	1500	580	UDS 212 KUER/TR
		Solenoid	Solenoid	20	20	1500	635	UDS 212 KUEC/KUEC
		Solenoid pilot assisted	Solenoid pilot assisted	20	20	1500	635	UDS 212 KUER/KUER
	5/3 closed centre	Solenoid	Mechanical spring	30	35	1000	720	UDS 212 SUEC/SUEC
		Solenoid pilot assisted	Mechanical spring	30	35	1000	720	UDS 212 SUER/SUER
	5/3 open centre	Solenoid	Mechanical spring	30	35	1200	720	UDS 212 AUEC/AUEC
		Solenoid pilot assisted	Mechanical spring	30	35	1200	720	UDS 212 AUER/AUER
	5/3 pressure centre	Solenoid	Mechanical spring	30	35	1300	720	UDS 212 PUEC/PUEC
		Solenoid pilot assisted	Mechanical spring	30	35	1300	720	UDS 212 PUER/PUER

***/EX** Consistent with the ATEX directive II 2GD c T5 T100°C -20°C ≤ Ta ≤ 50°C E.G.: **UDS 212 KUEC/TQ/EX**

THE TYPES OF THE SOLENOID VALVES DO NOT INCLUDE COILS

P.S.: SUBSTITUTE THE LETTER "E" WITH THE LETTER "P" IN EACH SOLENOID CONTROL TYPE TO ORDER THE SOLENOID ACTUATED VALVES TO ISO STANDARD WITH MANUAL OVERRIDE (MONOSTABLE BUTTON) ON THE PILOTING SOLENOID VALVES, E.G.: **UDS 212 KUEC/TR** BECOMES **UDS 212 KUPC/TR** - **UDS 212 KUEC/KUEC** BECOMES **UDS 212 KUPC/KUPC**

5 PORT SIZE 2 MONOSTABLE

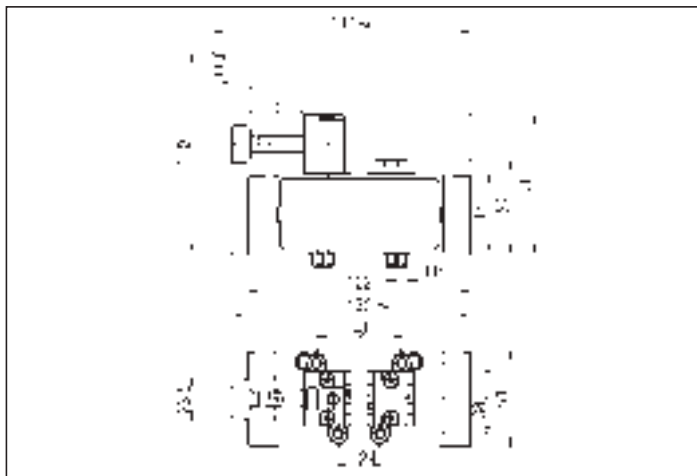

5 PORT SIZE 2 BISTABLE AND 3 POSITIONS

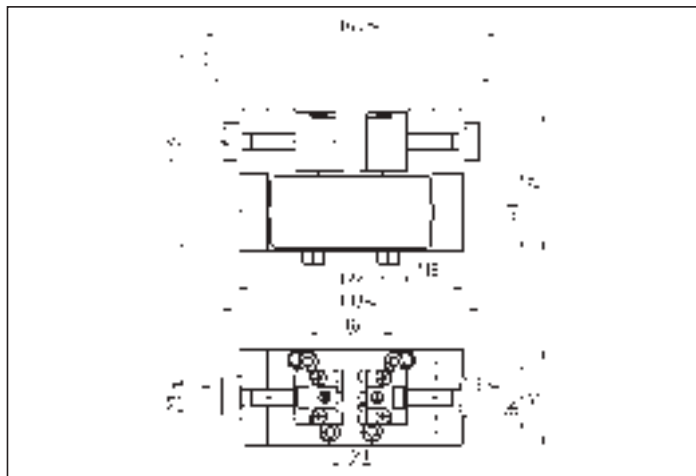

2

PILOT ACTUATED VALVES SIZE 3

Symbol	Function	Controls		Response time at 6 bar (ms)		Flow rate at 6 bar $\Delta P = 1 \text{ bar (Nl/min)}$	Weight (g)	TYPE*
		Pilot	Return	Energized	De-energized			
	5/2 monostable	Pneumatic	Mechanical spring	38	42	3000	1995	UDSI 3 KR/ZR
		Pneumatic	Pneumatic spring	38	42	3000	1985	UDSI 3 KR/TQ
	5/2 bistable	Pneumatic	Pneumatic	28	28	3000	1965	UDSI 3 KR/KR
		Big pneumatic	Small pneumatic	28	35	3000	1965	UDSI 3 KR/TR
	5/3 closed centre	Pneumatic	Mechanical spring	27	32	2900	2020	UDSI 3 SR/SR
	5/3 open centre	Pneumatic	Mechanical spring	27	32	3000	2020	UDSI 3 AR/AR

*EX Consistent with the ATEX directive II 2GD c T5 T100°C -20°C ≤ Ta ≤ 50°C E.G.: UDSI 3 KR/ZR/EX

5 PORT SIZE 3

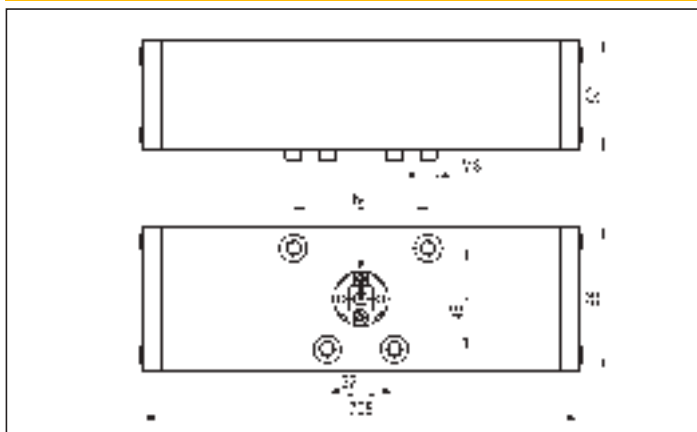

2

SOLENOID ACTUATED VALVES SIZE 3

Symbol	Function	Controls		Response time at 6 bar (ms)		Flow rate at 6 bar $\Delta P = 1 \text{ bar (Nl/min)}$	Weight (g)	TYPE*
		Pilot	Return	Energized	De-energized			
	5/2 monostable	Solenoid	Mechanical spring	40	42	3100	2120	UDSI 3 KUEC/ZR
		Solenoid	Pneumatic spring	40	42	3100	2120	UDSI 3 KUEC/TQ
		Solenoid pilot assisted	Mechanical spring	40	42	3100	2120	UDSI 3 KUER/ZR
	5/2 bistable	Solenoid	Small pneumatic	40	45	3100	2120	UDSI 3 KUEC/TR
		Solenoid pilot assisted	Small pneumatic	40	45	3100	2120	UDSI 3 KUER/TR
		Solenoid	Solenoid	28	28	3100	2180	UDSI 3 KUEC/KUEC
		Solenoid pilot assisted	Solenoid pilot assisted	28	28	3100	2180	UDSI 3 KUER/KUER
	5/3 closed centre	Solenoid	Mechanical spring	27	32	2900	2180	UDSI 3 SUEC/SUEC
		Solenoid pilot assisted	Mechanical spring	27	32	2900	2180	UDSI 3 SUER/SUER
	5/3 open centre	Solenoid	Mechanical spring	27	32	3000	2180	UDSI 3 AUEC/AUEC
		Solenoid pilot assisted	Mechanical spring	27	32	3000	2180	UDSI 3 AUER/AUER

***/EX** Consistent with the ATEX directive II 2GD c T5 T100°C -20°C ≤ Ta ≤ 50°C E.G.: **UDSI 3 KUEC/TQ/EX**

THE TYPES OF THE SOLENOID VALVES DO NOT INCLUDE COILS

P.S.: SUBSTITUTE THE LETTER "E" WITH THE LETTER "P" IN EACH SOLENOID CONTROL TYPE TO ORDER THE SOLENOID ACTUATED VALVES TO ISO STANDARD WITH MANUAL OVERRIDE (MONOSTABLE BUTTON) ON THE PILOTING SOLENOID VALVES, E.G.: **UDSI 3 KUEC/TR** BECOMES **UDSI 3 KUPC/TR** - **UDSI 3 KUEC/KUEC** BECOMES **UDSI 3 KUPC/KUPC**

5 PORT SIZE 3 MONOSTABLE

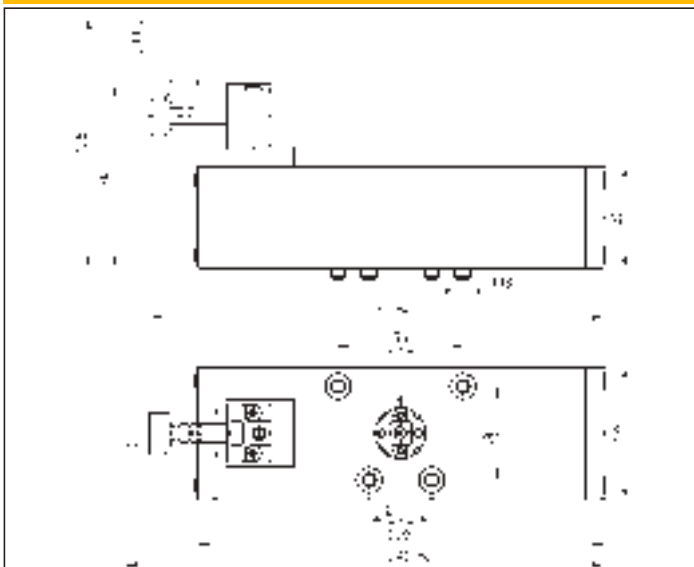

5 PORT SIZE 3 BISTABLE AND 3 POSITIONS

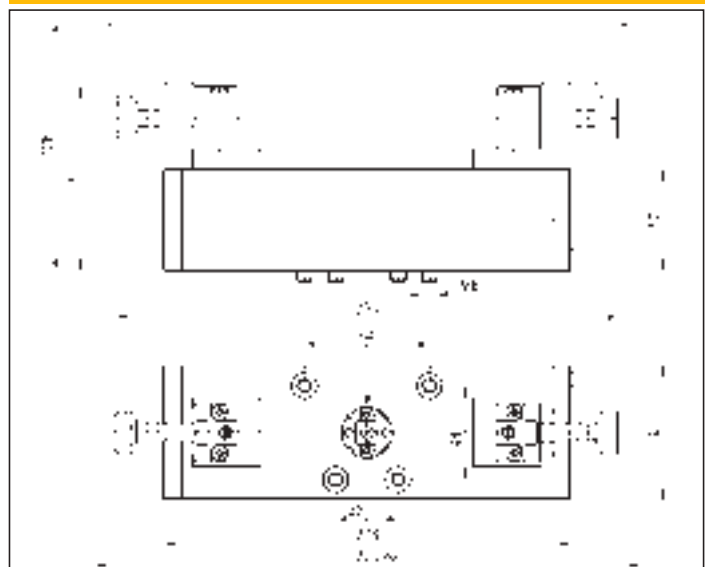

Accessories Single bases to ISO 5599/1 standard sizes 1-2-3 obtained from drawn light alloy

series UDS ISO

SINGLE BASE SIDE PORTED - UDP/ISO SIZE /S

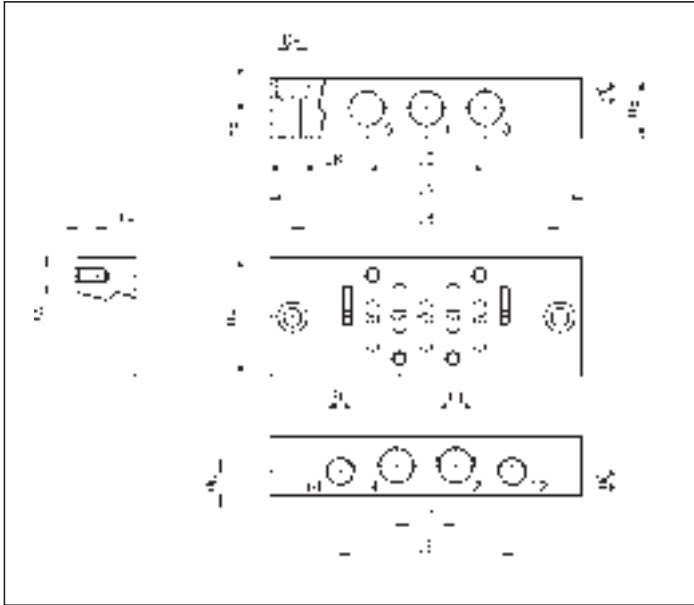

SINGLE BASE BOTTOM PORTED - UDP/ISO SIZE /B

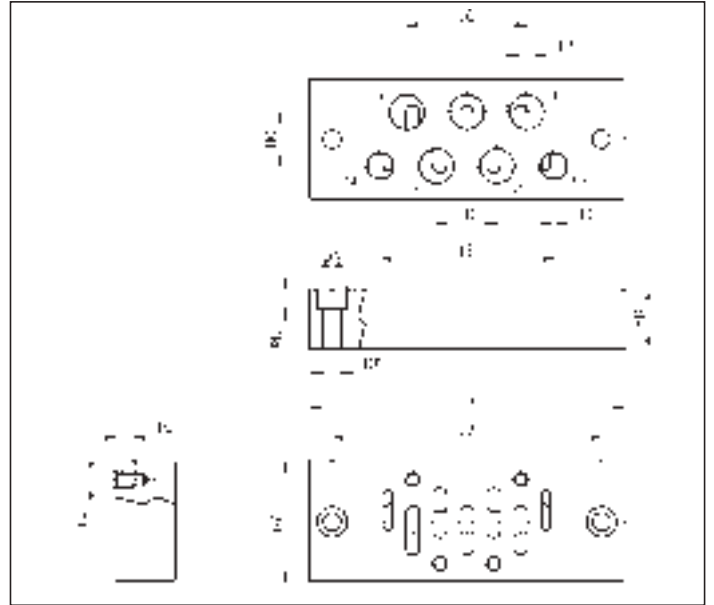

2

TYPE	UDP/ISO1/S8	UDP/ISO1/S4	UDP/ISO2/S4	UDP/ISO2/S3	UDP/ISO3/S2
Weight (g)	205	240	485	455	1090
SIZE	1		2		3
DA	10	10	12	12	15
DB	6	6	7	7	9
FA	M5	M5	M6	M6	M8
FB	G 1/8	G 1/4	G 1/4	G 3/8	G 1/2
FC	G 1/8	G 1/8	G 1/8	G 1/8	G 1/8
HA	40	40	55	55	70
HB	20	25	28	28	32
HC	8	14,5	13	15	16
HD	8	8	8	8	8
LA	105	105	130	130	208
LB	90	90	110	110	180
LC	36	40	48	52	64
LD	18	20	24	26	32
LE	58	58	68	70	90
PA	6,5	6,5	10	10	10
PB	6,5	6,5	8	8	11

TYPE	UDP/ISO1/B8	UDP/ISO1/B4	UDP/ISO2/B4	UDP/ISO2/B3	UDP/ISO3/B2
Weight (g)	200	190	495	470	1160
SIZE	1		2		3
DA	10	10	12	12	15
DB	6	6	7	7	9
FA	M5	M5	M6	M6	M8
FB	G 1/8	G 1/4	G 1/4	G 3/8	G 1/2
FC	G 1/8	G 1/8	G 1/8	G 1/8	G 1/8
HA	40	40	55	55	70
HB	20	20	28	28	32
HC	16	18	22	23	27
LA	105	105	130	130	208
LB	90	90	110	110	180
LC	36	40	48	52	64
LD	18	20	24	26	32
LE	58	58	68	70	90
PA	8	8	10	10	10
PB	6,5	6,5	8	8	11

series UDS ISO

Accessories Manifold bases
to ISO 5599/1 standard sizes 1-2-3
obtained from drawn light alloy

2

MANIFOLD BASE SIDE PORTED - UDP/ISO SIZE /MS/Q

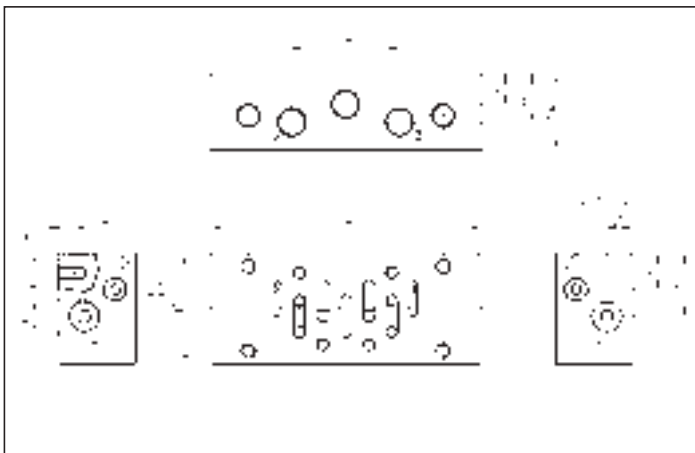

TYPE	UDP/ISO1/8MS/Q	UDP/ISO1/4MS/Q	UDP/ISO2/3MS/Q
Weight (g)	320	310	660
SIZE	1	1	2
FA	M5	M5	M6
FB	G 1/8	G 1/4	G 3/8
FC	G 1/8	G 1/8	G 1/8
HA	43	43	55
HB	30	30	40
HC	19	19	24
HD	12	12	17
HE	14	14	17,5
HF	24,5	24,5	30
LA	105	105	130
LB	42	42	54
LC	22	22	30
LD	10	10	12,5
PA	6,5	6,5	8

MANIFOLD BASE BOTTOM PORTED - UDP/ISO SIZE M/Q

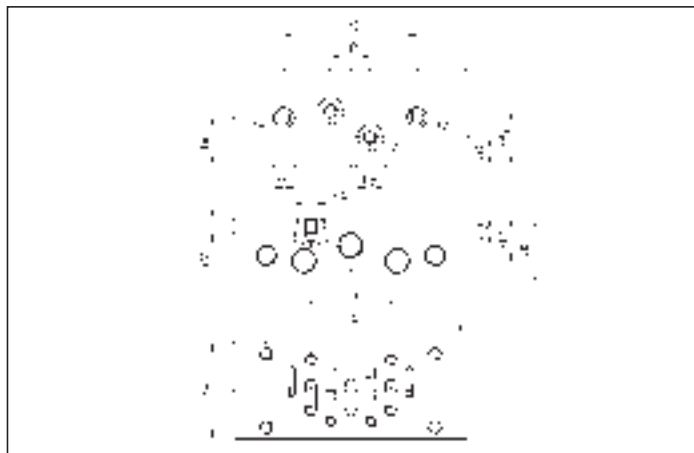

TYPE	UDP/ISO1/4M/Q	UDP/ISO2/3M/Q	UDP/ISO3/2M/Q
Weight (g)	315	665	1640
SIZE	1	2	3
FA	M5	M6	M8
FB	G 1/4	G 3/8	G 1/2
FC	G 1/8	G 1/8	G 1/8
HA	43	55	70
HB	30	40	50
HC	19	24	27
HD	12	17	27
HE	21,5	27,5	35
HF	12,5	16,5	23,5
HG	24,5	32,5	42,5
LA	105	130	208
LB	42	54	88
LC	60	74	125
LD	18	24	42
PA	6,5	8	10

INPUT PLATES (PAIR) - UDP/ISO SIZE /...M/L

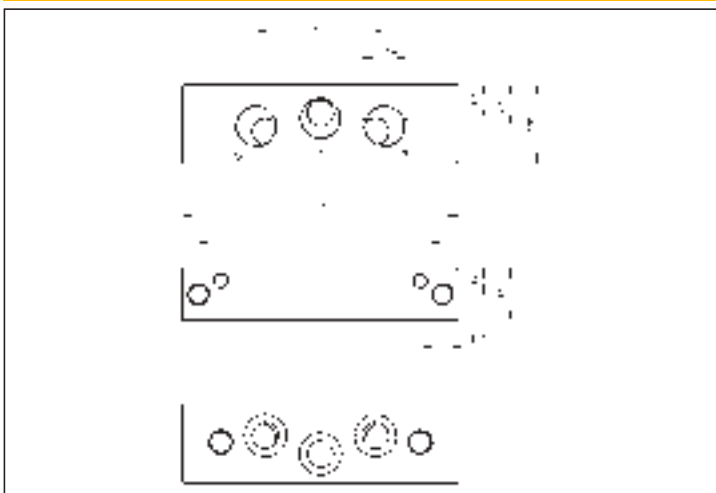

TYPE	UDP/ISO1/3M/L	UDP/ISO2/2M/L	UDP/ISO3/1M/L
Weight (g)	280	460	2355
SIZE	1	2	3
DA	7	7	9
FA	G 3/8	G 1/2	G 1
HA	20	20	50
HB	30	40	50
HC	16	22	25
HD	13	15	25
HE	10	10	25
LA	105	130	208
LB	49	59	94
LC	93	118	180

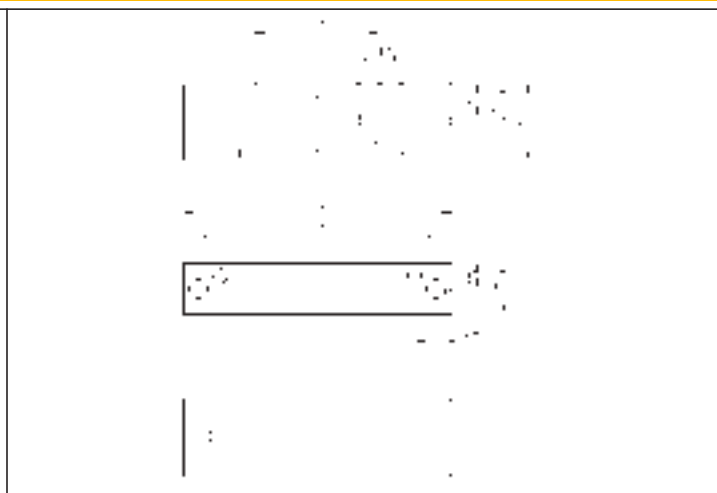

BLANKING PLATE ISO 1 - UDP/ISO1/PC BLANKING PLATE ISO 2 - UDP/ISO2/PC



WEIGHT 80 g

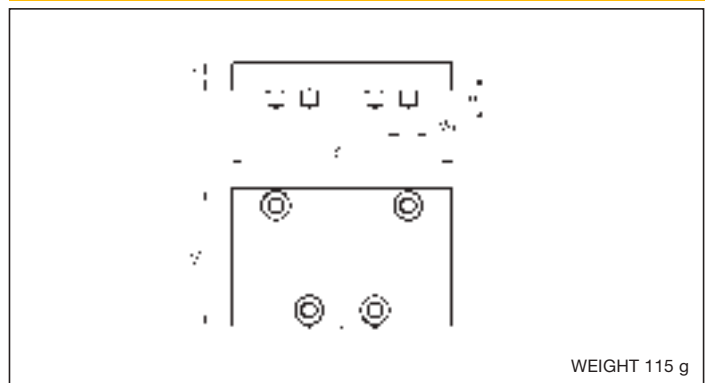

WEIGHT 115 g

SIZE ADAPTER ISO 1-2 AND ISO 2-3 - UDP/ISO SIZE

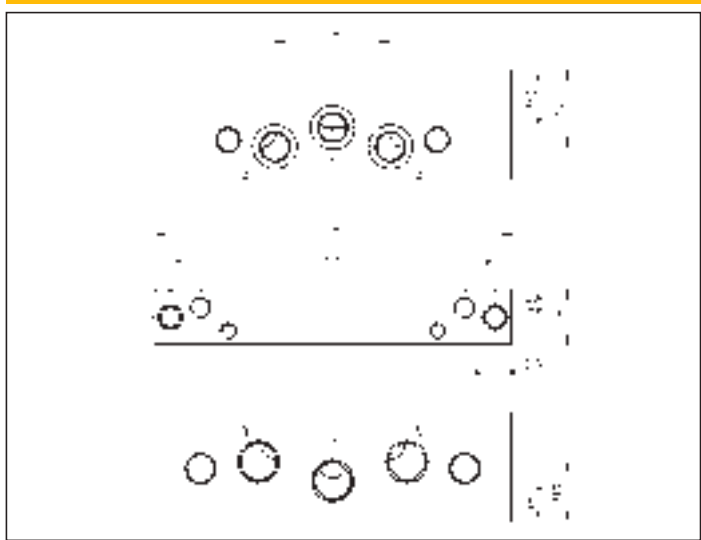

TYPE	UDP/ISO1-2	UDP/ISO2-3
Weight (g)	245	1305
SIZE	1-2	2-3
DA	7	9
HA	20	50
HB	40	50
HC	28	32
HD	21	35
HE	10	25
HF	15	25
HG	22	25
LA	130	208
LB	42	54
LC	118	180
LD	54	88

KIT ASSEMBLY BASES

Kit assembly bases SIZE 1	KIT/UDP/ISO 1
Kit assembly bases SIZE 2	KIT/UDP/ISO 2
Kit assembly bases SIZE 3	KIT/UDP/ISO 3

DIAPHRAGM - UDP/ISO SIZE /T

TYPE	UDP/ISO1/T	UDP/ISO2/T	UDP/ISO3/T
SIZE	1	2	3

EXAMPLE OF ASSEMBLY

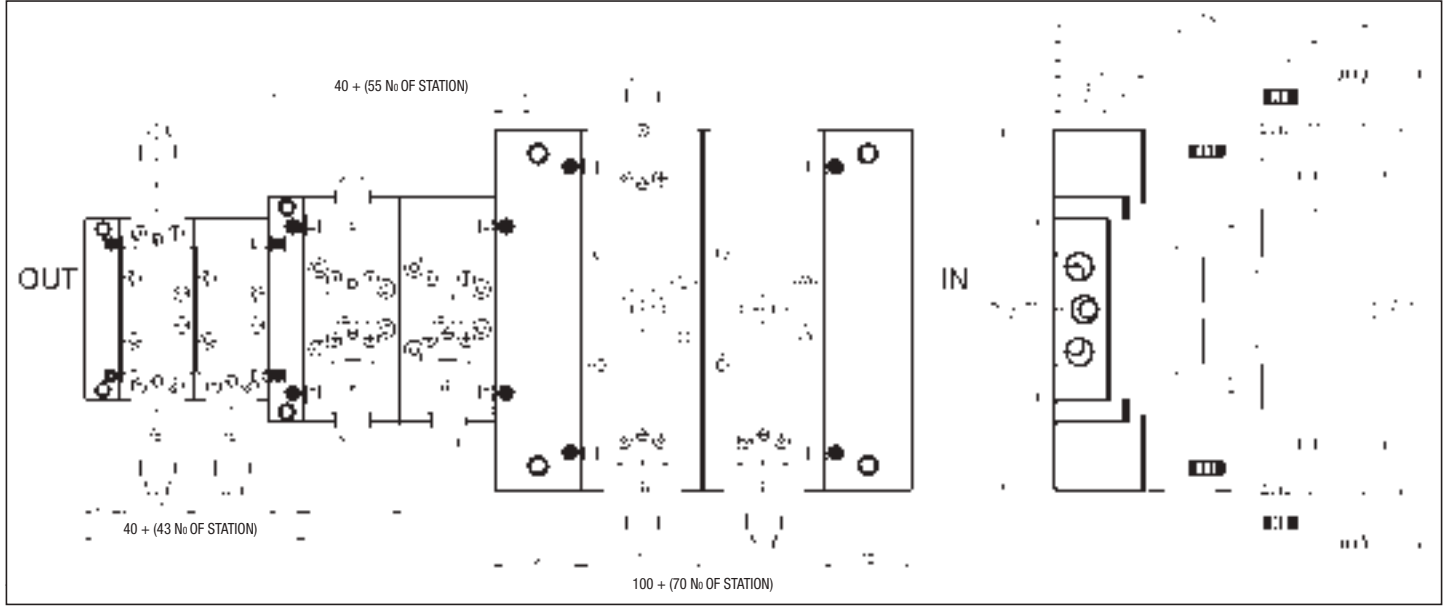

series UDS ISO

Accessories Manifold bases
to ISO 5599/1 standard size 1
obtained from die-cast light alloy

2

INPUT PLATE - UDP/ISO2PE

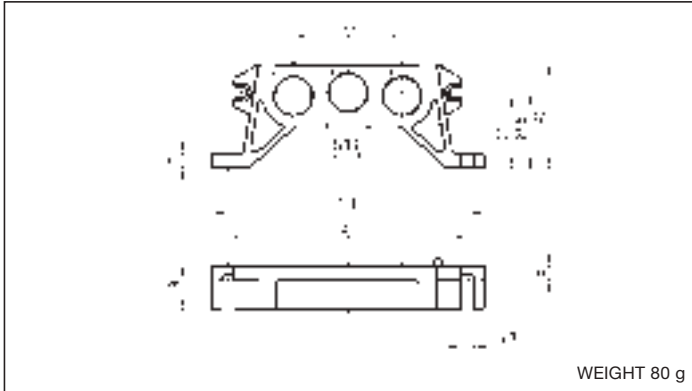

WEIGHT 80 g

INPUT PLATE IS SUPPLIED COMPLETE WITH SCREWS AND SEALS

BLIND TERMINAL PLATE - UDP/ISO2PT

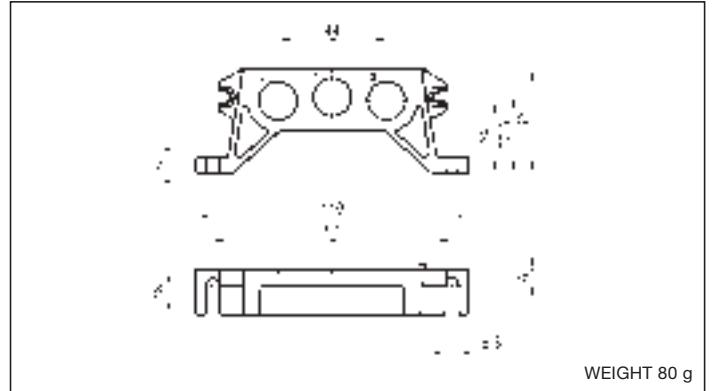

WEIGHT 80 g

UNIVERSAL PLATE

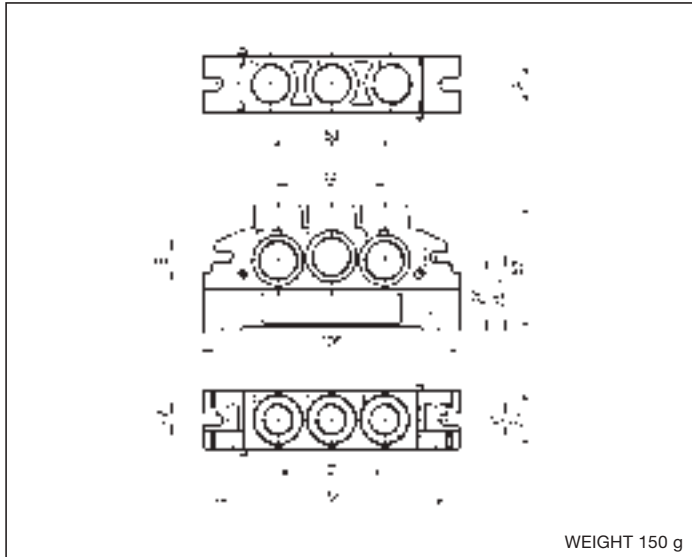

WEIGHT 150 g

DESCRIPTION	A	B	C	TYPE
Intermediate plate, bottom ported	G 3/8	-	-	UDP/ISO1PUI
Intermediate plate, side ported	-	G 3/8	-	UDP/ISO1PUL
Intermediate plate, top ported	-	-	G 1/4	UDP/ISO1PUS
Intermediate plate with blind holes	G 3/8	G 3/8	G 1/4	UDP/ISO1PU

PLATES ARE SUPPLIED COMPLETE WITH SCREWS AND SEALS

MANIFOLD BASE, SIDE AND BOTTOM PORTED - UDP/ISO2BM

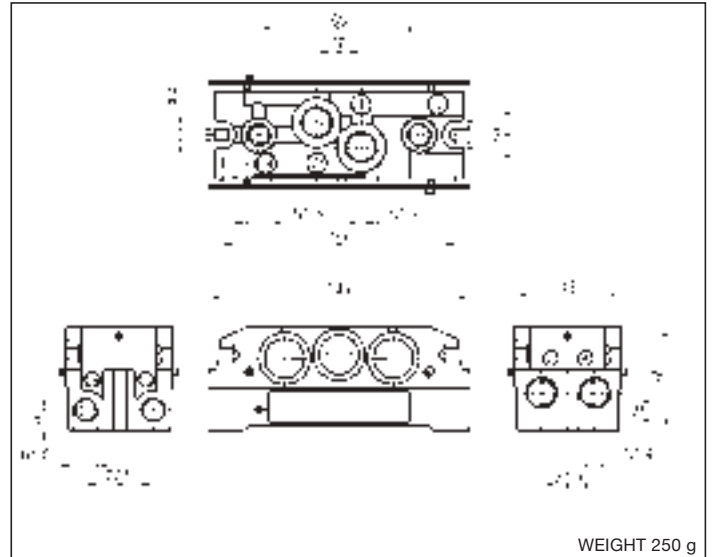

WEIGHT 250 g

MANIFOLD BASE IS SUPPLIED COMPLETE WITH SCREWS, SEALS AND PLUGS (USE A FLUID SEAL)

DIAPHRAGM - UDP/ISO1D

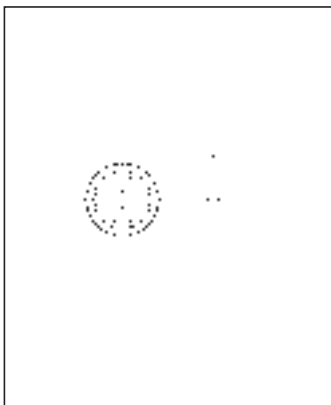

DIAPHRAGM - UDP/ISO2D

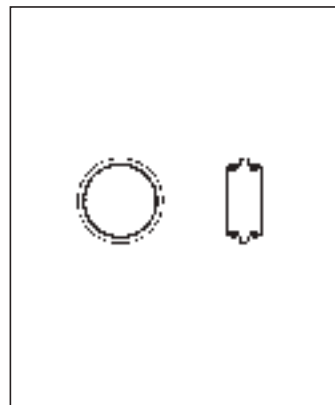

SIZE ADAPTER ISO 1-2 - UDP/ISODT1-2

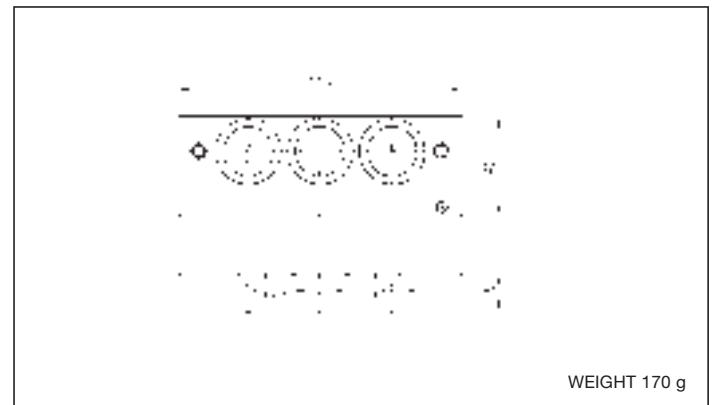

WEIGHT 170 g

SIZE ADAPTER IS SUPPLIED COMPLETE WITH SCREWS AND SEALS

INPUT PLATE - UDP/ISO2PE

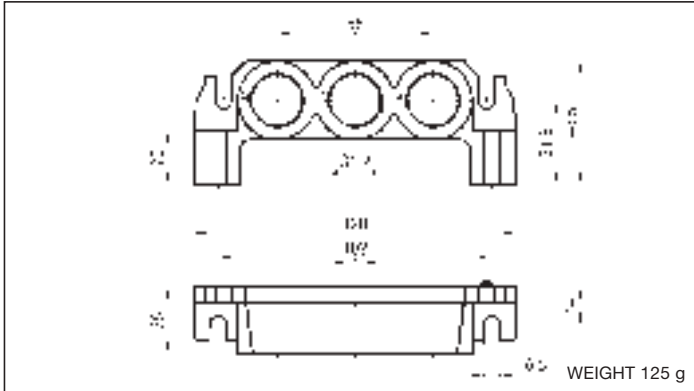

INPUT PLATE IS SUPPLIED COMPLETE WITH SCREWS AND SEALS

BLIND TERMINAL PLATE - UDP/ISO2PT

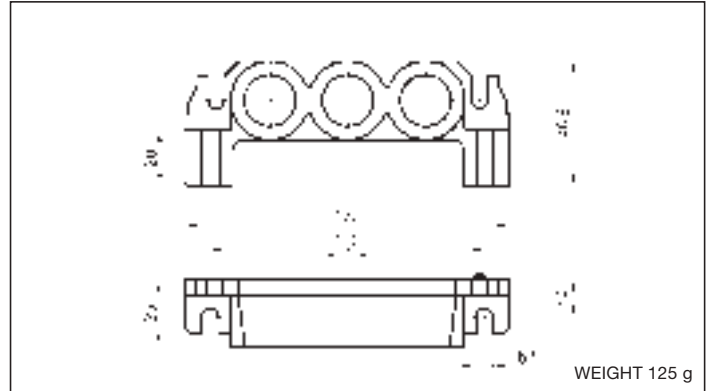

UNIVERSAL PLATE

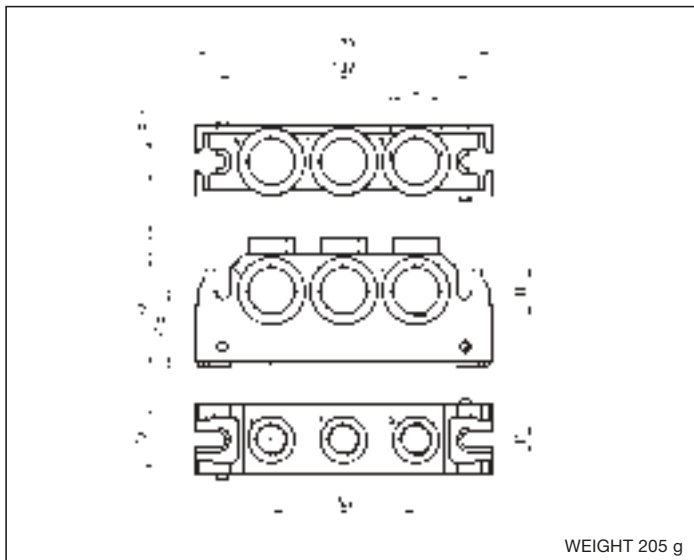

DESCRIPTION	A	B	C	TYPE
Intermediate plate, bottom ported	G 1/2	-	-	UDP/ISO2PUI
Intermediate plate, side ported	-	G 1/2	-	UDP/ISO2PUL
Intermediate plate, top ported	-	-	G 1/4	UDP/ISO2PUS
Intermediate plate with blind holes	G 1/2	G 1/2	G 1/4	UDP/ISO2PU

PLATES ARE SUPPLIED COMPLETE WITH SCREWS AND SEALS

MANIFOLD BASE, SIDE AND BOTTOM PORTED - UDP/ISO2BM

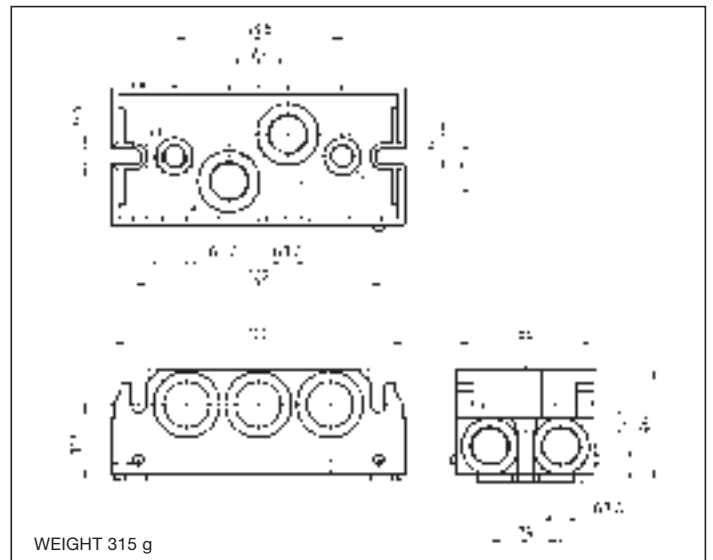

MANIFOLD BASE IS SUPPLIED COMPLETE WITH SCREWS, SEALS AND PLUGS (WITH THE HEAD OF THE SCREW PLAIN WITH THE BASE AND USE A FLUID SEAL)

EXAMPLE OF ASSEMBLY

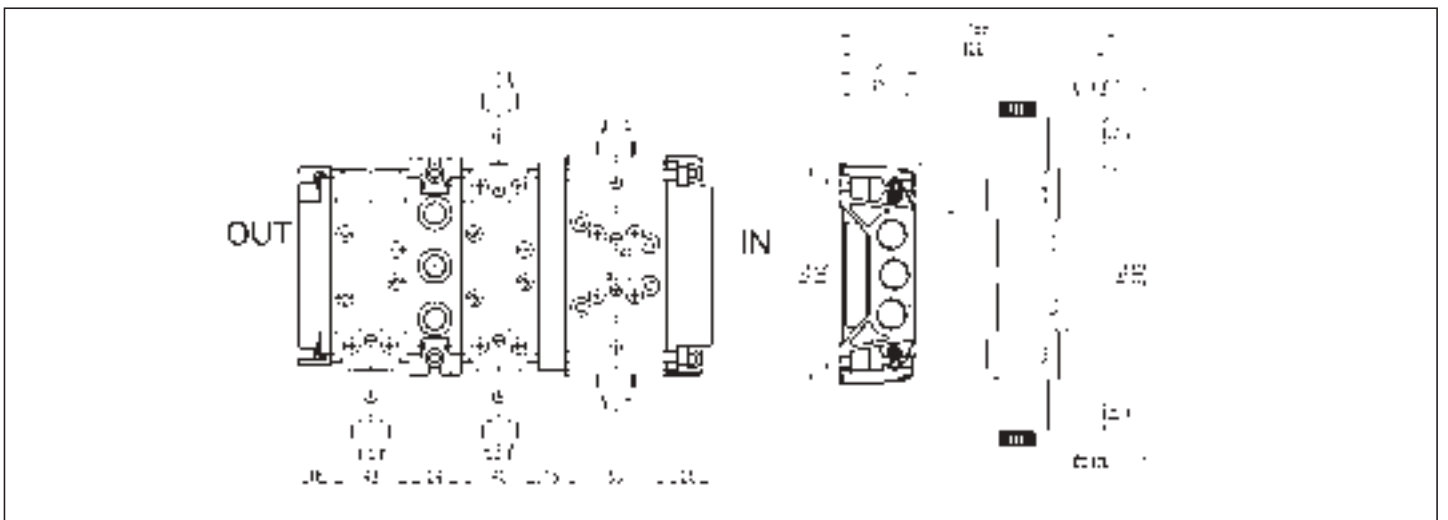

series UDS CETOP

Valves to ex CETOP RP 32 P
standard pilot and solenoid
actuated sizes 05 - 12 - 35

DESCRIPTION

Valves series "UDS CETOP" are produced in the 5/2 and 5/3 pneumatic functions according to the interface to ex CETOP RP 32 P standard and they are mounted onto single bases, bottom or side ported, or onto manifold bases, bottom ported. All the solenoid actuated versions support the 32 mm direct acting solenoid valve type ULCSV/R (with fixed position) or the amplifier valve type XVF4 for a sensible pneumatic piloting (see page 3.37).



2

TECHNICAL DATA

Operating pressure	Monostable: 2,5 ÷ 10 bar Bistable: 2 ÷ 10 bar
Working temperature	0 ÷ +70 °C (-20 °C with dry air)
Fluid	Compressed air, filtered, continuous lubricated, unlubricated or dry lubricated
Port size	Interface to ex CETOP RP 32 P standard
Pneumatic piloting port size	Interface to ex CETOP RP 32 P standard
Piloting solenoid valve	ULCSV/R - see chapter direct acting solenoid valves on page 2.9
Pneumatic piloting valve	XVF4 - see chapter complementary valves on page 3.37
Electric connector	ULR1B - see chapter connectors on page 2.18

MATERIALS

Bottoms	Anodized aluminium alloy
Body	Anodized aluminium alloy
Distance rings	Acetal resin
Springs	Galvanized steel
Seals	NBR rubber + steel insert
Spool	Anodized aluminium alloy
Piston	Anodized aluminium alloy

SPARE PARTS

SEALS KIT	
Size 05	UDS/SG/05
Size 12	UDS/SG/12
Size 35	UDS/SG/35

FLOW CHART SIZE 05

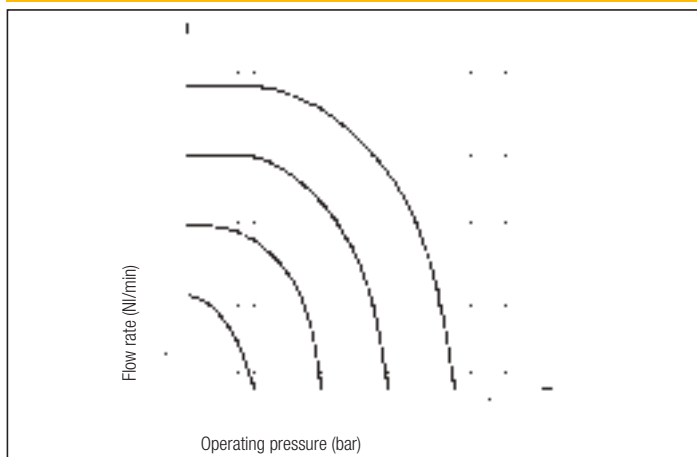

PILOTING CHART SIZE 05

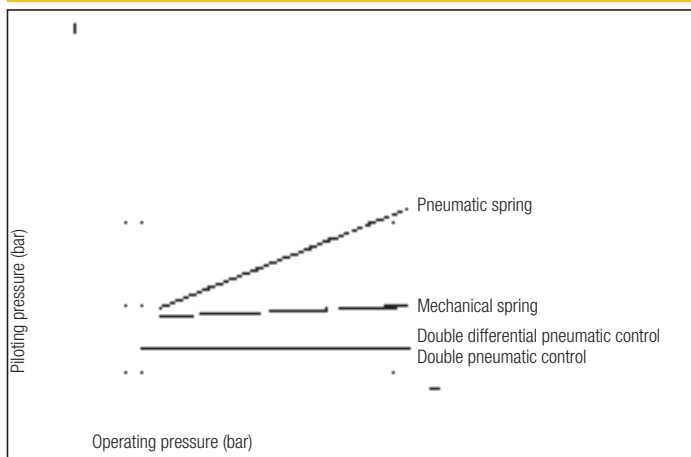

FLOW CHART SIZE 12

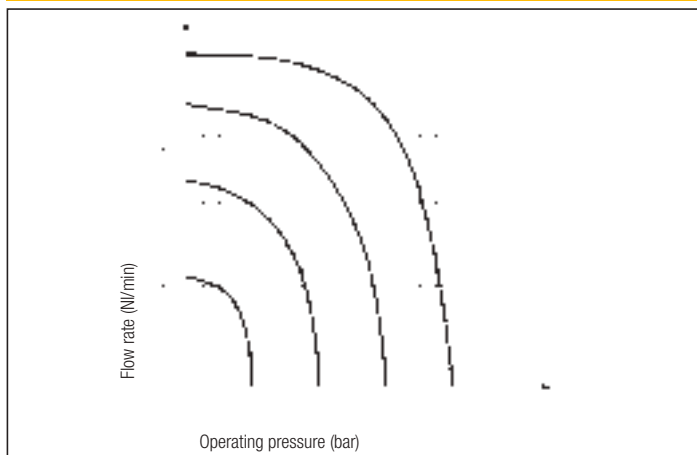

PILOTING CHART SIZE 12

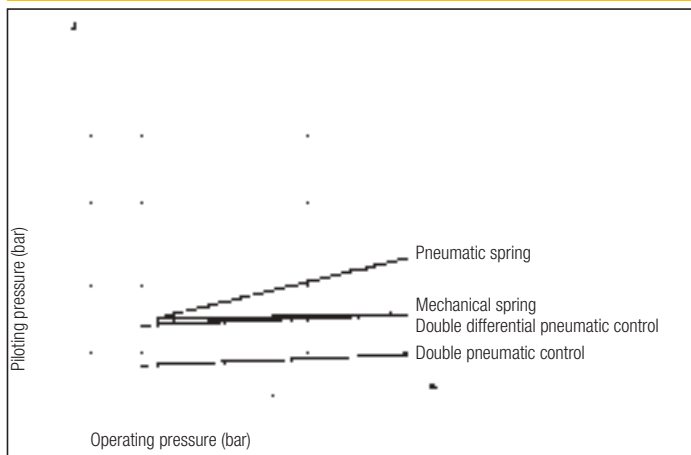

FLOW CHART SIZE 35

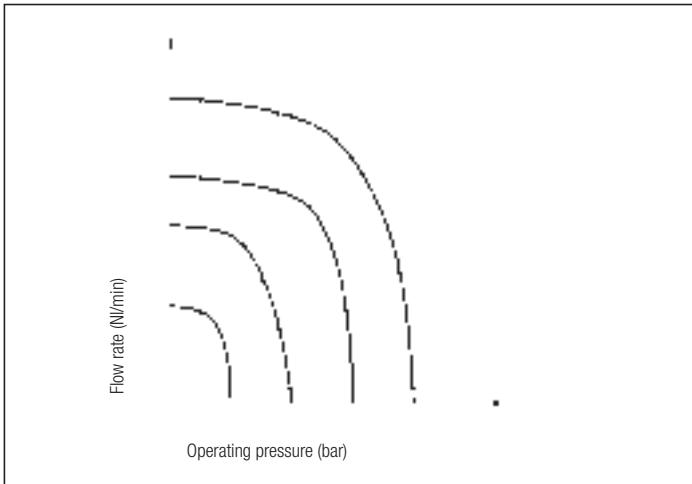

PILOTING CHART SIZE 35

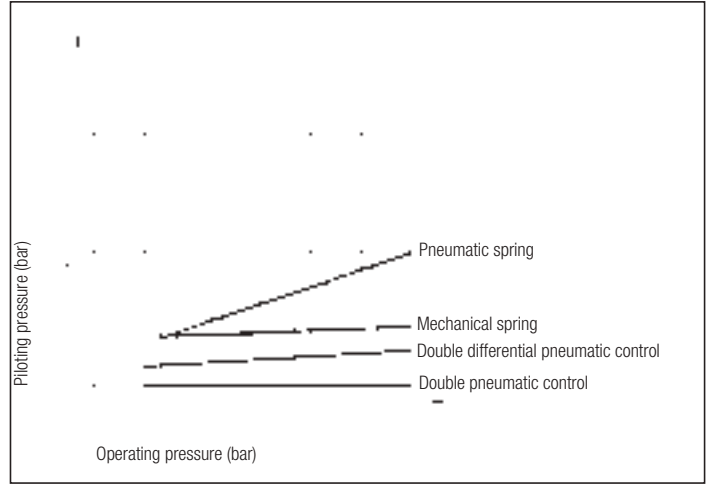

PILOT ACTUATED VALVES* SIZES 05 - 12 - 35

Symbol	Function	Controls		Response time at 6 bar (ms)		Flow rate at 6 bar $\Delta P = 1$ bar (NI/min)	Weight (g)	Size	TYPE*
		Pilot	Return	Energized	De-energized				
	5/2 monostable	Pneumatic	Mechanical spring	29	38	415	310	05	UDS 05 KR/ZR
				30	48	950	760	12	UDS 12 KR/ZR
				42	41	2800	1945	35	UDS 35 KR/ZR
		Mechanical spring	Pneumatic	29	38	415	310	05	UDS 05 ZR/KR
				30	48	950	760	12	UDS 12 ZR/KR
				42	41	2800	1945	35	UDS 35 ZR/KR
	5/2 monostable	Pneumatic	Pneumatic spring	42	34	415	325	05	UDS 05 KR/TQ
				44	59	950	770	12	UDS 12 KR/TQ
				69	71	2800	1900	35	UDS 35 KR/TQ
		Pneumatic spring	Pneumatic	42	34	415	325	05	UDS 05 TQ/KR
				44	59	950	770	12	UDS 12 TQ/KR
				69	71	2800	1900	35	UDS 35 TQ/KR
	5/2 bistable	Pneumatic	Pneumatic	27	27	415	305	05	UDS 05 KR/KR
				28	28	950	745	12	UDS 12 KR/KR
				36	36	2800	1910	35	UDS 35 KR/KR
		Big Pneumatic	Small pneumatic	27	27	415	310	05	UDS 05 KR/TR
				28	28	950	770	12	UDS 12 KR/TR
				36	36	2800	1900	35	UDS 35 KR/TR
		Small pneumatic	Big pneumatic	27	27	415	310	05	UDS 05 TR/KR
				28	28	950	770	12	UDS 12 TR/KR
				36	36	2800	1900	35	UDS 35 TR/KR
	5/3 open centre	Pneumatic	Mechanical spring	30	34	315	325	05	UDS 05 SR/SR
				42	33	815	790	12	UDS 12 SR/SR
				27	31	2650	1980	35	UDS 35 SR/SR

* FOR THE LOW PRESSURE PILOT ACTUATED VALVES OBTAINABLE WITH "XVF4" SEE THE TABLE SOLENOID ACTUATED VALVES ON PAGE 2.104

5 PORT

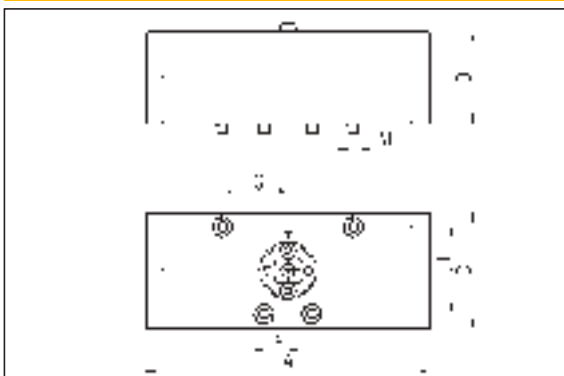

SIZE	A	C	D	E	F	G	M
05	104	38	30	9	26	24	M4
12	130	53	42	11	40	30	M5
35	208	68	52	20	48	54	M8

SOLENOID ACTUATED VALVES SIZES 05 - 12 - 35

Symbol	Function	Controls		Response time at 6 bar (ms)		Flow rate at 6 bar $\Delta P = 1 \text{ bar (Nl/min)}$	Weight (g)	Size	TYPE*	
		Pilot	Return	Energized	De-energized					
	5/2 monostable	Solenoid	Mechanical spring	29	38	415	310	05	UDS 05 KUC/ZR	
				30	48	950	765	12	UDS 12 KUC/ZR	
				47	39	2800	1970	35	UDS 35 KUC/ZR	
		Mechanical spring	Solenoid		29	38	415	310	05	UDS 05 ZR/KUC
					30	48	950	765	12	UDS 12 ZR/KUC
					47	39	2800	1970	35	UDS 35 ZR/KUC
		Solenoid pilot assisted	Mechanical spring		29	38	415	310	05	UDS 05 KUR/ZR
					30	48	950	765	12	UDS 12 KUR/ZR
					47	39	2800	1970	35	UDS 35 KUR/ZR
		Mechanical spring	Solenoid pilot assisted		29	38	415	310	05	UDS 05 ZR/KUR
					30	48	950	765	12	UDS 12 ZR/KUR
					47	39	2800	1970	35	UDS 35 ZR/KUR
	Solenoid	Pneumatic spring		42	34	415	325	05	UDS 05 KUC/TQ	
				44	59	950	785	12	UDS 12 KUC/TQ	
				76	49	2800	1940	35	UDS 35 KUC/TQ	
	Pneumatic spring	Solenoid		42	34	415	325	05	UDS 05 TQ/KUC	
				44	59	950	785	12	UDS 12 TQ/KUC	
				76	49	2800	1940	35	UDS 35 TQ/KUC	
	5/2 bistable	Solenoid	Pneumatic	27	27	415	305	05	UDS 05 KUC/KR	
				28	28	950	745	12	UDS 12 KUC/KR	
				36	36	2800	1910	35	UDS 35 KUC/KR	
		Pneumatic	Solenoid		27	27	415	310	05	UDS 05 KR/KUC
					28	28	950	765	12	UDS 12 KR/KUC
					36	36	2800	1910	35	UDS 35 KR/KUC
		Solenoid pilot assisted	Pneumatic		27	27	415	310	05	UDS 05 KUR/KR
					28	28	950	765	12	UDS 12 KUR/KR
					36	36	2800	1910	35	UDS 35 KUR/KR
		Pneumatic	Solenoid pilot assisted		27	27	415	310	05	UDS 05 KR/KUR
					28	28	950	765	12	UDS 12 KR/KUR
					36	36	2800	1910	35	UDS 35 KR/KUR
		Solenoid	Solenoid		27	27	415	305	05	UDS 05 KUC/KUC
					28	28	950	745	12	UDS 12 KUC/KUC
					36	36	2800	1910	35	UDS 35 KUC/KUC
		Solenoid pilot assisted	Solenoid pilot assisted		27	27	415	305	05	UDS 05 KUR/KUR
					28	28	950	745	12	UDS 12 KUR/KUR
					36	36	2800	1910	35	UDS 35 KUR/KUR
		Solenoid	Small pneumatic		27	27	415	315	05	UDS 05 KUC/TR
					28	28	950	775	12	UDS 12 KUC/TR
					36	36	2800	1900	35	UDS 35 KUC/TR
		Small pneumatic	Solenoid		27	27	415	315	05	UDS 05 TR/KUC
					28	28	950	775	12	UDS 12 TR/KUC
					36	36	2800	1900	35	UDS 35 TR/KUC
	Solenoid pilot assisted	Small pneumatic		27	27	415	315	05	UDS 05 KUR/TR	
				28	28	950	775	12	UDS 12 KUR/TR	
				36	36	2800	1900	35	UDS 35 KUR/TR	
	Small pneumatic	Solenoid pilot assisted		27	27	415	315	05	UDS 05 TR/KUR	
				28	28	950	775	12	UDS 12 TR/KUR	
				36	36	2800	1900	35	UDS 35 TR/KUR	
	5/3 closed centre	Solenoid	Mechanical spring	30	34	315	325	05	UDS 05 SUC/SUC	
				42	33	815	795	12	UDS 12 SUC/SUC	
				34	38	2650	1980	35	UDS 35 SUC/SUC	
		Solenoid pilot assisted	Mechanical spring		30	34	315	325	05	UDS 05 SUR/SUR
					42	33	815	795	12	UDS 12 SUR/SUR
					34	38	2650	1980	35	UDS 35 SUR/SUR

* THE TYPES OF THE SOLENOID VALVES DO NOT INCLUDE THE PILOTING SOLENOID VALVES (SEE ON PAGE 2.9 FOR "ULCSV/R") WHEREAS USING AS PILOT THE VALVE "XVF4" THE RESULT IS A LOW PRESSURE PILOT ACTUATED VALVE (FOR "XVF4" - SEE ON PAGE 3.37)

5 PORT MONOSTABLE

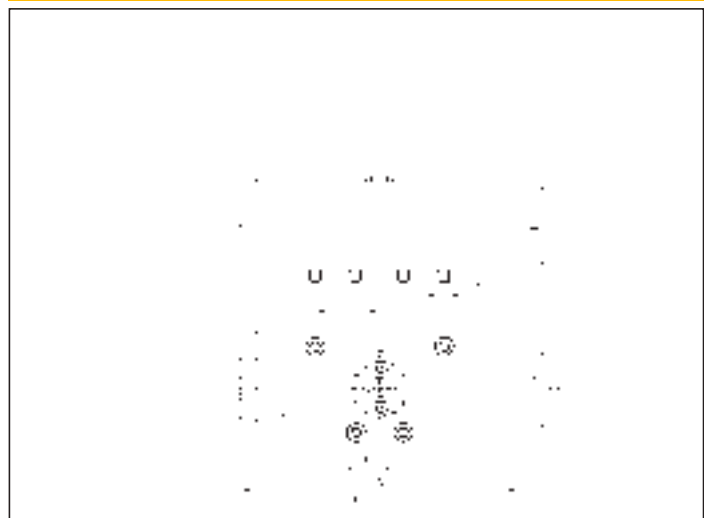

5 PORT AND 3 POSITIONS BISTABLE

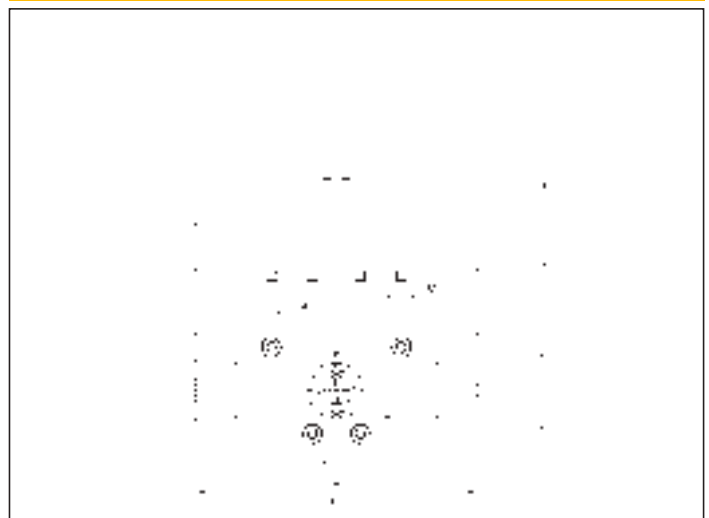

SIZE	A	B	C	D	E	F	G	H	H1	M
05	104	105	38	30	9	26	18	135	120	M4
12	130	117	53	42	11	40	30	158	144	M5
35	208	127	68	52	20	58	54	233	221	M8

SINGLE BASE, BOTTOM PORTED - UDP..B

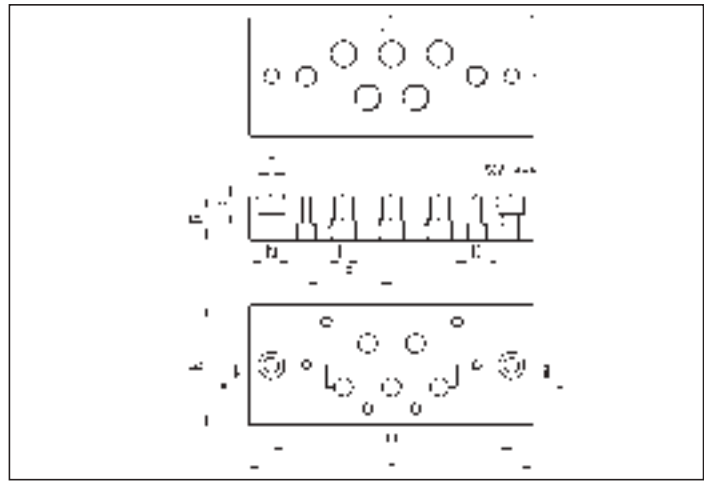

SINGLE BASE, SIDE PORTED - UDP..S

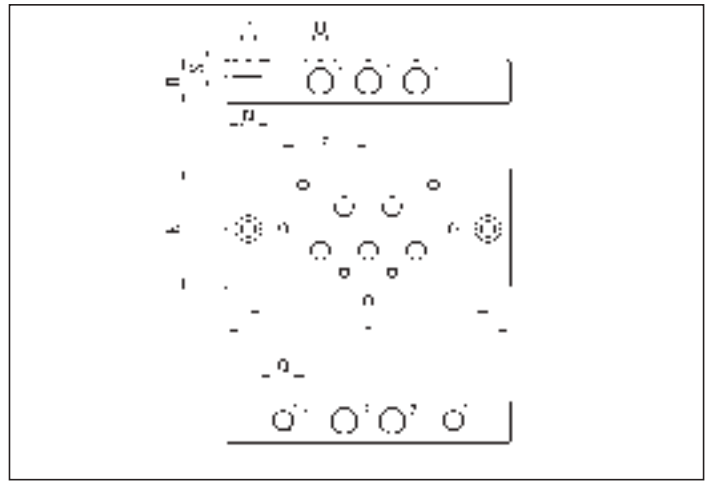

TYPE	Weight (g)	TYPE	Weight (g)	TYPE	E	K	L	N	O	Q	R	S	T	U
UDP8B	170	UDP8S	160	05	30	40	105	6	90	G 1/8	16	6,5	10	G 1/8
UDP4B	365	UDP4S	340	12	39	55	130	7	110	G 1/8	20	8	12	G 1/4
UDP2B	1170	UDP2S	1125	35	65	70	208	9	180	G 1/8	32	11	15	G 1/2

series UDS CETOP

Sizes 05 - 12 - 35
and manifold bases

MANIFOLD BASES, BOTTOM PORTED - UDP...M/

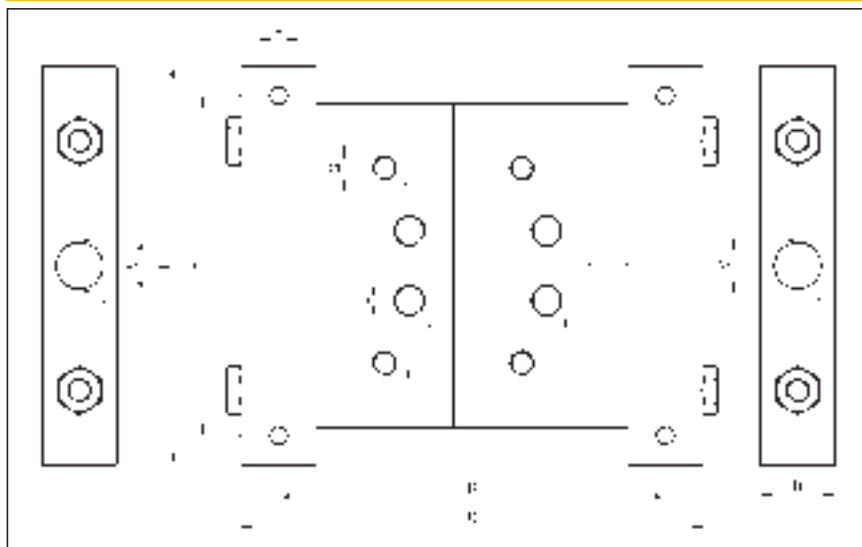

2

SIZE	A	D	F	H	Q	U	V
05	110	30	130	6	G 1/8	G 1/8	G 1/4
12	136	40	160	7	G 1/8	G 1/4	G 1/2
35	210	50	240	9	G 1/8	G 1/2	G 3/4

No of stations	2	3	4	5	6	7	8	9	10
B	115	155	195	235	275	315	355	395	435
C	150	190	230	270	310	350	390	430	470
Weight (g)	1165	1480	1795	2110	2425	2740	3055	3370	3685
TYPE Size 05	UDP8M/2	UDP8M/3	UDP8M/4	UDP8M/5	UDP8M/6	UDP8M/7	UDP8M/8	UDP8M/9	UDP8M/10
B	155	210	265	320	375	430	485	540	595
C	197	252	307	362	417	472	527	582	63
Weight (g)	2340	3040	3740	4440	5140	5840	6540	7240	7940
TYPE Size 12	UDP4M/2	UDP4M/3	UDP4M/4	UDP4M/5	UDP4M/6	UDP4M/7	UDP4M/8	UDP4M/9	UDP4M/10
B	170	240	310	380	-	-	-	-	-
C	236	306	376	446	-	-	-	-	-
Weight (g)	5680	7240	9000	10760					
TYPE Size 35	UDP2M/2	UDP2M/3	UDP2M/4	UDP2M/5	-	-	-	-	-

DESCRIPTION

The solenoid valves series "W" can be directly actuated, servo-assisted or with mixed actuation. These solenoid valves, produced in the 2/2 N.C. pneumatic function, are used in several industrial fields, thanks to their compatibility with a large range of fluids.

TECHNICAL DATA

Operating pressure	(See tables below)
Working temperature range	NBR -10 ÷ +90 °C EPDM < +140 °C FPM -10 ÷ +130 °C
Fluid	See technical information on page 0.5
Port size	G 1/8 ÷ G 2
Coils	WE3A - see on page 2.109 WE2A - see on page 2.109 WE5A - see on page 2.109
Electric connectors	USR102/N9 - see chapter connectors on page 2.18 ULR1B - see chapter connectors on page 2.18
Seal type	Duty field
NBR	Water max. 70 °C, air max. 90 °C, mineral oils and derivatives - hydrocarbons (methane, ethane, propane, butane, kerosene and gas oil)
EPDM	Hot water and steam max. 140 °C, detergents, solutions of sodium and potassium, hydraulic fluids and polar solvents (not to be used with mineral oils and grease)
FPM (Viton®)	For general purpose max. 130 °C

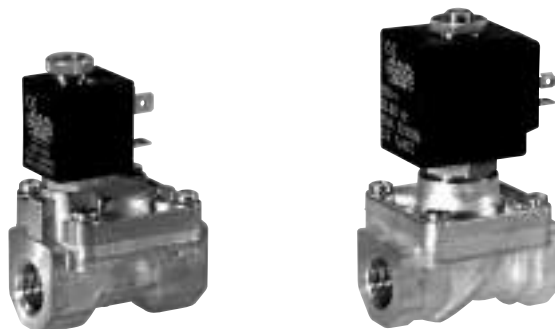

2

MATERIALS

Body	Brass
Sleeve	Brass
Moving core	Stainless steel
Springs	Stainless steel
Seals	NBR EPDM FPM

2 PORT G 1/8 - DIRECTLY ACTUATED

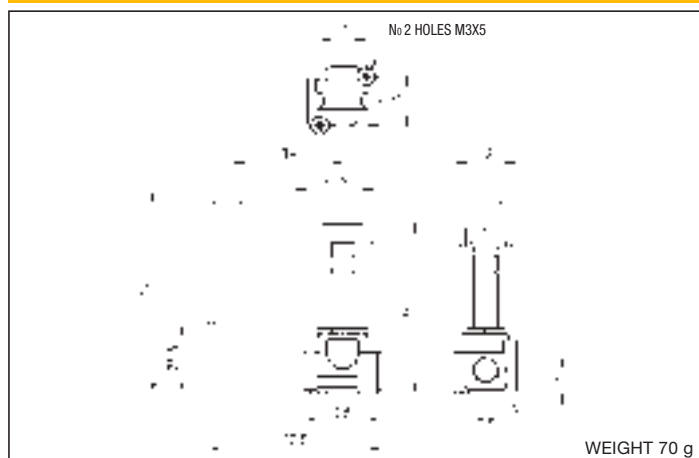

Symbol	Function	Differential pressure (bar)			Kv	Nominal orifice (mm)	Port size	TYPE
		MIN.	MAX.					
			AC	DC				
[Symbol]	2/2 N.C.	0	25	25	0,04	1,2	G 1/8	W 105 1 * E3A
		0	16	16	0,06	1,5	G 1/8	W 105 2 * E3A
		0	12	10	0,09	2	G 1/8	W 105 3 * E3A
		0	8	5,5	0,14	2,5	G 1/8	W 105 4 * E3A
		0	5	2	0,19	3,1	G 1/8	W 105 5 * E3A

* SPECIFY THE SEALING TYPE: B = NBR; V = FPM; E = EPDM

P.S.: THE TYPES OF THE SOLENOID VALVES DO NOT INCLUDE COILS (SEE "WE3A" ON PAGE 2.109)

2

2 PORT G 1/8 - G 1/4 DIRECTLY ACTUATED

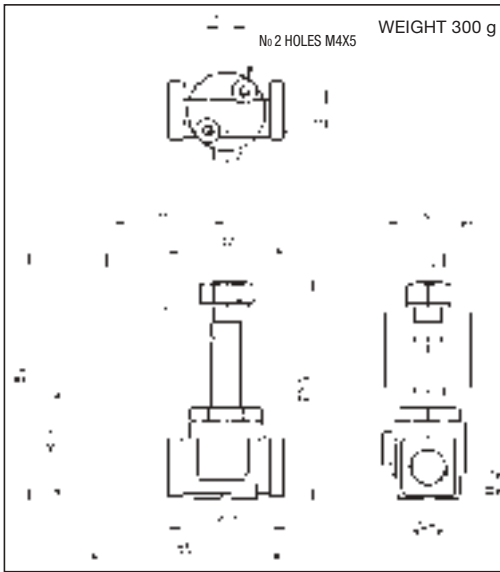

Symbol	Function	Differential pressure (bar)		Kv	Nominal orifice (mm)	Port size (GA)	TYPE	
		MIN.	MAX.					
			AC					DC
	2/2 N.C.	0	30	26	0,07	1,5	G 1/8	W106 1 * E2A
		0	22	20	0,1	2	G 1/8	W106 2 * E2A
		0	16	14	0,15	2,5	G 1/8	W 106 3 * E2A
		0	10	8	0,32	3,5	G 1/8	W 106 4 * E2A
		0	30	26	0,07	1,5	G 1/4	W 106 5 * E2A
		0	22	20	0,1	2	G 1/4	W 106 6 * E2A
		0	16	14	0,15	2,5	G 1/4	W 106 7 * E2A
		0	10	8	0,32	3,5	G 1/4	W 106 8 * E2A
		0	6,5	3,5	0,41	4,5	G 1/4	W 106 9 * E2A
		0	4	1,8	0,47	5,2	G 1/4	W 106 10 * E2A
		0	-	1	0,64	6,4	G 1/4	W 106 11 * E2A

* SPECIFY THE SEALING TYPE: B = NBR; V = FPM; E = EPDM

P.S.: THE TYPES OF THE SOLENOID VALVES DO NOT INCLUDE COILS (SEE "WE2A" ON PAGE 2.109)

2 PORT G 3/8 - G 2 SERVO ASSISTED

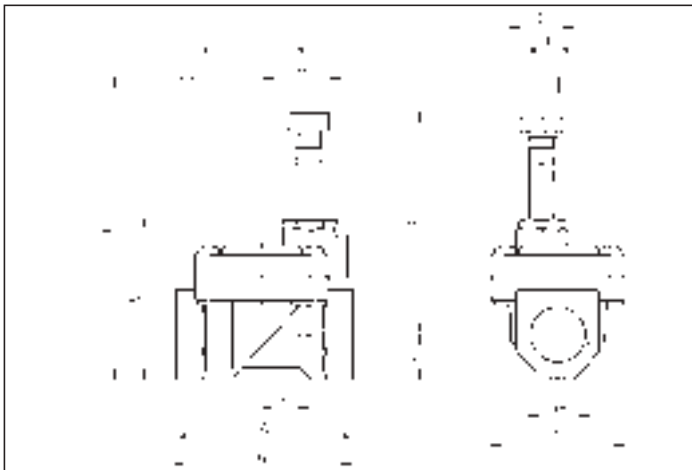

Symbol	Function	Differential pressure (bar)		Kv	Nominal orifice (mm)	Port size (GA)	TYPE	
		MIN.	MAX.					
			AC					DC
	2/2 N.C.	0,15	15	15	2	12	G 3/8	W 107 1 * E3A
		0,15	15	15	2,2	12	G 1/2	W 107 2 * E3A
		0,15	13	13	5,2	18	G 3/4	W 107 3 * E3A
		0,15	10	10	10,2	24	G 1	W 107 4 * E3A
		0,15	10	10	18	37	G 1 1/4	W 107 5 * E2A
		0,15	10	10	21	37	G 1 1/2	W 107 6 * E2A
		0,15	10	10	36	50	G 2	W 107 7 * E2A

* SPECIFY THE SEALING TYPE: B = NBR; V = FPM; E = EPDM

P.S.: THE TYPES OF THE SOLENOID VALVES DO NOT INCLUDE COILS (SEE "WE2A" AND "WE3A" ON PAGE 2.109)

THAT HAVE PREFERABLY TO BE MOUNTED TOWARD THE HIGH

GA	A	B	C	D	E	F	G	H	I	L	M	N	WEIGHT (g)
G 3/8	60	70	14	45	16	6	22	27,5	39	102	53,5	62,5	450
G 1/2	60	70	14	45	16	6	22	27,5	39	102	53,5	62,5	450
G 3/4	75	74	18	55	20	8,5	22	27,5	39	108	59,5	66	660
G 1	96	85	20	72	32	-	22	27,5	39	120	71,5	64,5	1200
G 1 1/4	144	107	28	102	45	-	30	42	39,5	128	79,5	75,5	3200
G 1 1/2	144	107	28	102	45	-	30	42	39,5	128	79,5	75,5	2900
G 2	152	116,5	35	119	48	-	30	42	39,5	159	110,5	76,5	4500

2 PORT G 3/8 - G 1 WITH MIXED ACTUATION

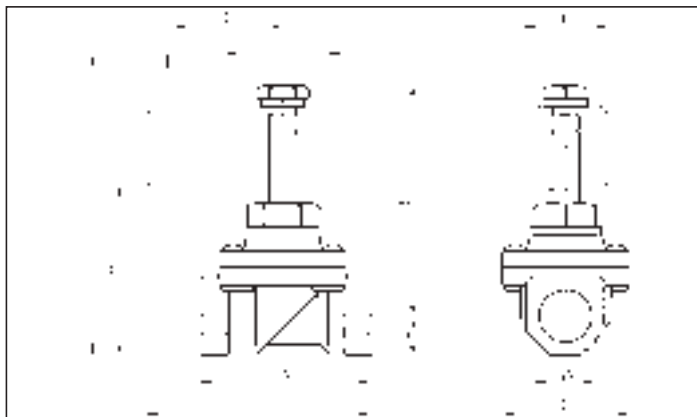

GA	A	B	C	D	E WE2A	E WE5A	F WE2A	F WE5A
G 3/8	59	83	14	45	30	36	42	47,5
G 1/2	59	83	14	45	30	36	42	47,5
G 3/4	79	90	18	55	-	36	-	47,5
G 1	96	101	20	72	-	36	-	47,5

G WE2A	G WE5A	H WE2A	H WE5A	I WE2A	I WE5A	L WE2A	L WE5A	WEIGHT (g)
39,5	42,5	58,5	58	106	105,5	79	82	580
39,5	42,5	58,5	58	106	105,5	79	82	530
-	42,5	-	69	-	116,5	-	89,5	750
-	42,5	-	82	-	129,5	-	100	1200

2

Symbol	Function	Differential pressure (bar)			Kv	Nominal orifice (mm)	Port size (GA)	TYPE
		MIN.	MAX.					
			AC	DC				
	2/2 N.C.	0	10	-	2	12	G 3/8	W 108 1 V E2A
		0	10	-	2,2	12	G 1/2	W 108 2 V E2A
		0	12	10	2	12	G 3/8	W 108 1 V E5A
		0	12	10	2,2	12	G 1/2	W 108 2 V E5A
		0	9	-	4,5	18	G 3/4	W 108 3 V E5A
		0	7	-	8,5	24	G 1	W 108 4 V E5A

SEAL ONLY FPM

P.S.: THE TYPES OF THE SOLENOID VALVES DO NOT INCLUDE COILS (SEE "WE2A" AND "WE3A") THAT HAVE PREFERABLY TO BE MOUNTED TOWARD THE HIGH

COIL TYPE WE3A

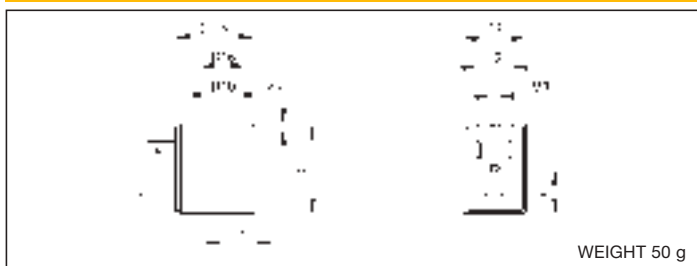

Power consumption	DC: 6,5 W AC: 8 VA holding - 12 VA inrush
-------------------	--

DESCRIPTION	TYPE
COIL 22 mm 24 V DC	WE3A/02400
COIL 22 mm 24 V AC	WE3A/02450-60
COIL 22 mm 110 V AC	WE3A/11050-60
COIL 22 mm 220 V AC	WE3A/22050-60

ELECTRIC CONNECTOR USR 102/N9 (see on page 2.18)

COIL TYPE WE2A

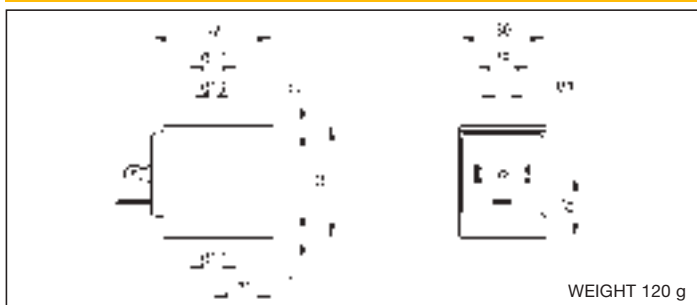

Power consumption	DC: 10 W AC: 15 VA holding - 20 VA inrush
-------------------	--

DESCRIPTION	TYPE
COIL 30 mm 24 V DC	WE2A/02400
COIL 30 mm 24 V AC	WE2A/02450-60
COIL 30 mm 110 V AC	WE2A/11050-60
COIL 30 mm 220 V AC	WE2A/22050-60

ELECTRIC CONNECTOR ULR 1B (see on page 2.18)

COIL TYPE WE5A



Power consumption	DC: 27 W AC: 30 VA holding - 40 VA inrush
-------------------	--

DESCRIPTION	TYPE
COIL 36 mm 24 V DC	WE5A/02400
COIL 36 mm 24 V AC	WE5A/02450-60
COIL 36 mm 110 V AC	WE5A/11050-60
COIL 36 mm 220 V AC	WE5A/22050-60

ELECTRIC CONNECTOR ULR 1B (see on page 2.18)

DESCRIPTION

Valves for vacuum series "EV" are produced only in the 3/2 N.O. and 3/2 N.C. pneumatic functions with solenoid pilot assisted actuation. Their function is to work with positive or negative pressure (vacuum) opening or closing the fluid passages. You can get the N.O. version feeding the valve from port "3".



TECHNICAL DATA

Operating pressure	(-1 bar ÷ 10 bar)
Pneumatic piloting pressure	3 ÷ 10 bar
Working temperature	-20 ÷ +50 °C
Fluid temperature	+50°C max
Port size	G 1/8 - G 1/4 - G 3/8 - G 1/2 - G 3/4 - G 1 - G 1½ - G 2
Coils	G 1/8: WE3A - see chapter Coils on page 2.109 G 1/4 - G 3/8: USB - see chapter Coils on page 2.17 G 1/2 ÷ G 2: WE2A - see chapter Coils on page 2.109
Electric connectors	USR102/N9 - see chapter Connectors on page 2.18 ULR1B - see chapter Connectors on page 2.18

MATERIALS

Bottoms	Anodized aluminium
Body	Anodized aluminium
Springs	Stainless steel
Sleeve	Nickel-plated brass
Core	Stainless steel
Piston	Aluminium
Diaphragm and plunger	Polyurethane

3 PORT SOLENOID PILOT ASSISTED ACTUATED VALVES

Symbol	Function	Controls		Response time at 6 bar (ms)		Maximum flow rate pump (m3/h)	Port size	Weight	TYPE*
		Pilot	Return	Energized	De-energized				
	3/2 N.C. - 3/2 N.O.	Solenoid pilot assisted	Mechanical spring	15	25	1,5	G 1/8	163	EV8
	3/2 N.C. - 3/2 N.O.			18	28	4	G 1/4	462	EV4
	3/2 N.C. - 3/2 N.O.			18	28	10	G 3/8	451	EV3
	3/2 N.C. - 3/2 N.O.			20	40	20	G 1/2	780	EV2
	3/2 N.C. - 3/2 N.O.			20	40	20	G 3/4	750	EV6
	3/2 N.C. - 3/2 N.O.			20	45	35	G 1	1212	EV1
	3/2 N.C. - 3/2 N.O.			60	40	180	G 1½	3300	EV12
	3/2 N.C. - 3/2 N.O.			80	50	250	G 2	9800	EV16

P.S.: FOR VERSION N.O. ARRANGE THE CONNECTIONS AS INDICATED: 1 = EXHAUST
2 = OUTPUT
3 = PUMP

* THE TYPES OF THE SOLENOID VALVES DO NOT INCLUDE COILS

EV8 - EV4 - EV3

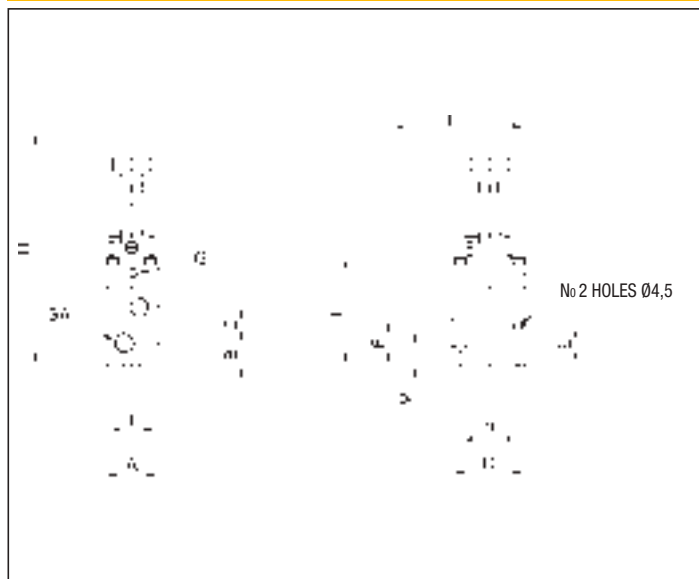

TYPE	A	B	C	D	E	F	G	GA	H	I	L	M	N	P
EV8	25	11	17.5	35	19.7	21.7	M5	G 1/8	112.7	7	52.7	9.2	28	65
EV4	32	17	23	50.5	28	28	G1/8	G 1/4	136	-	69.5	17	41	89
EV3	32	17	23	50.5	28	28	G1/8	G 3/8	136	-	69.5	17	41	89

EV2 - EV6 - EV1 - EV12 - EV16

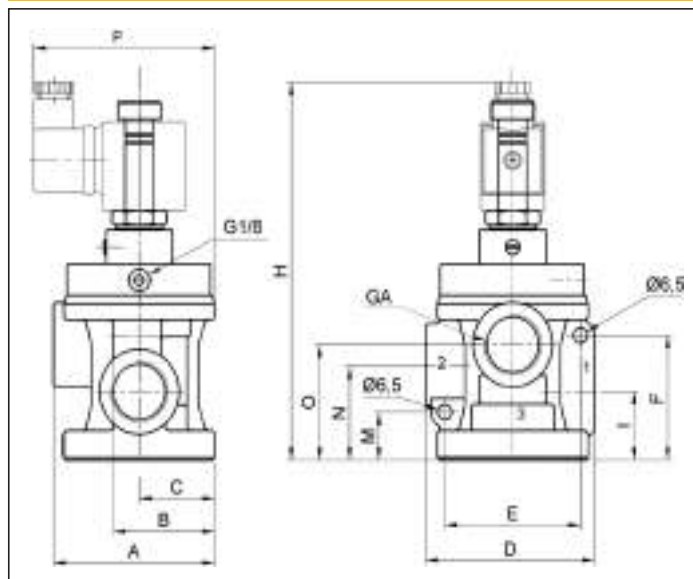

TYPE	A	B	C	D	E	F	GA	H	I	M	N	O	P
EV2	75	47	35	78.5	63	54.5	G 1/2	152	30	21	41	50.5	85.5
EV6	75	47	35	78.5	63	54.5	G 3/4	152	30	21	41	50.5	85.5
EV1	94	55	45	101	78	62.5	G 1	168	38	25.5	51	64	95
EV12	138	84	59	158	113	113	G 1½	240	68	34	68	96	-
EV16	183.5	113.5	78.5	210	150	152	G 2	310	92	48	92	129	-

DESCRIPTION

Valves series "VM" generate vacuum using the Venturi effect. These valves found a specific employment in the aspiration from single work points with a suction cap.



2

TECHNICAL DATA

Operating pressure	1 ÷ 10 bar
Fluid	Vacuum
Feeding fluid	Compressed air
Port size	G 1/8 - G 1/4 - G 3/8 - G 1/2 - G 3/4 - G 1
Nominal diameter	1,5 mm
Max. vacuum capability	- 0.7 bar

MATERIALS

Body	Anodized aluminium alloy
Nozzle	Brass
Seals	NBR rubber

SUCTION CHART

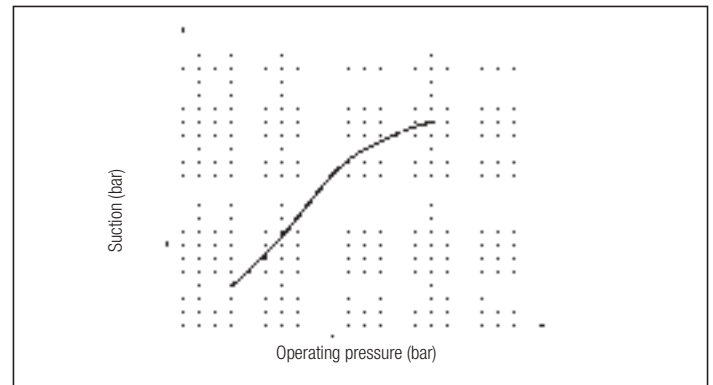

DIMENSIONS AND WEIGHT VM

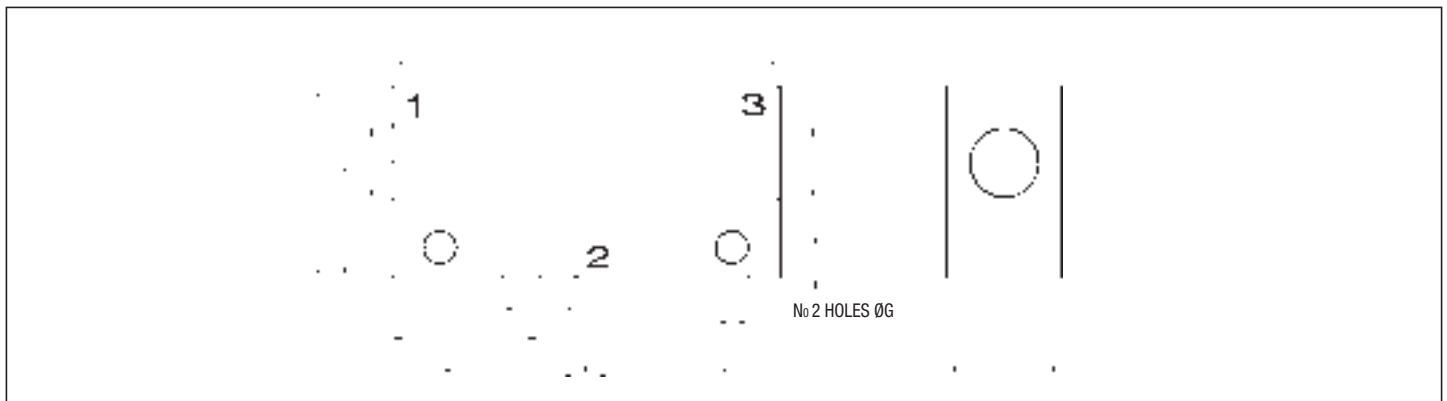

1 = FEEDING FLUID
2 = SUCTION
3 = EXHAUST

Symbol	A	B	C	D	E	F	G	I	H	L	WEIGHT (g)	TYPE
	50.5	25	38	15	19.2	4	4.2	15	G 1/8	G 1/8	50	VM8
	58	30	38	19.5	23	4	4.2	25	G 1/4	G 1/4	90	VM4
	71.5	30	52	18.5	31	4.5	5.2	25	G 3/8	G 3/8	146	VM3
	75	35	56	21	33	4.5	5.2	30	G 1/2	G 1/2	203	VM2
	90.5	50	61.5	28.5	49.4	4.5	5.2	50	G 3/4	G 1/4	692	VM15
	97	50	68	28.5	52.4	4.5	5.2	50	G 1	G 1/4	643	VM1

SUCTION FLOW RATE

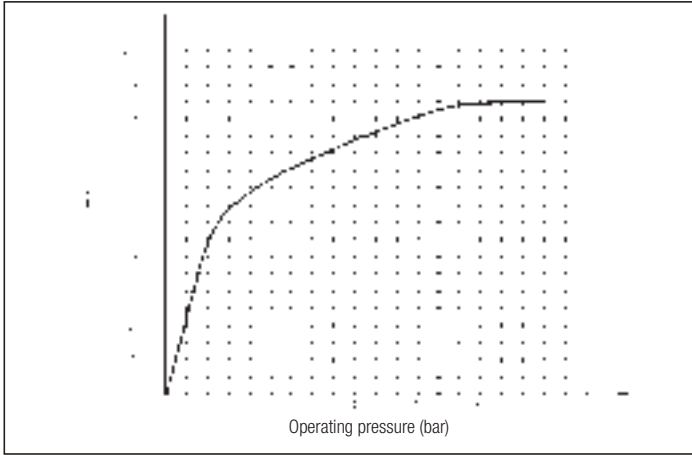



4

2

EKCA4/TF



3 MAX 10 bar

5

WARCOM
WEBB'S
MADE IN ENGLAND

2

EKCA4/TF



3 MAX 10 bar

4

5

WARCOM
WEBB'S
MADE IN ENGLAND

2

EKCA4/TF

3 MAX 10 bar

Series M

General features - Minivalves manually and mechanically actuated.....	page 3.2
Accessories: actuators for panel mounting	page 3.5

Series EK

General features	page 3.6
Spool valves mechanically actuated 3 and 5 port - G 1/8	page 3.7
Spool valves manually actuated 3 and 5 port - G 1/8	page 3.10
Spool valves mechanically actuated 3 and 5 port - G 1/4	page 3.12
Spool valves manually actuated 3 and 5 port - G 1/4	page 3.15
Spool valves manually actuated 5 port - G 1/2	page 3.17

Series CA

General features	page 3.19
Poppet valves mechanically actuated 2, 3 and 5 port - G 1/8 - G 1/4 - G 1/2	page 3.20
Poppet valves manually actuated 2 and 3 port - G 1/8 - G 1/4 - G 1/2	page 3.22
Poppet valves manually actuated 3 port / 3 positions and 5 port - G 1/8 - G 1/4 - G 1/2	page 3.24

Series PC

General features	page 3.27
Valves pedal actuated 3 and 5 port G 1/8 - G 1/4	page 3.28

Complementary valves

General features	page 3.30
------------------------	-----------

Series DS

Shuttle valves	page 3.30
----------------------	-----------

Series D3/

Quick exhaust valves	page 3.31
----------------------------	-----------

Series U

Check valves	page 3.31
--------------------	-----------

Series VC

Slide valves	page 3.31
--------------------	-----------

Series RX

Distribution frames	page 3.31
---------------------------	-----------

Series EL

General features - Pneumatic logic elements	page 3.32
---	-----------

Series UR

General features	page 3.34
In-line precision flow regulators type URG - URF	page 3.34
In-line standard flow regulators type URE	page 3.35
Silenced exhaust flow regulators type URS	page 3.35

Series WB

General features - Block valves	page 3.36
---------------------------------------	-----------

Series XVF

General features - Amplifier valves	page 3.37
---	-----------

DESCRIPTION

Minivalves series "M" are produced in the 2/2 and 3/2 pneumatic functions in both side and bottom ported versions, with push-in fittings on body valve for pipe Ø 4 mm or M5 threaded connections; the version G 1/8 bottom ported is also available. Thanks to the suitable adapter types MCS-SA and MCS-SAD these minivalves support the Ø 22 mm actuators for panel mounting. The same actuators can control 1 or 2 minivalves, thus it's possible to obtain the 3/2, 5/2, 5/3 open centre and the 5/3 pressure centre pneumatic functions. They are in compliance with ATEX directive, 2GD category, upon request.

TECHNICAL DATA

Operating pressure	2 ÷ 10 bar
Working temperature	0 ÷ +60 °C (-20 °C with dry air)
Fluid	Compressed air, filtered, continuous lubricated, unlubricated or dry lubricated
Port size	Push-in fittings for pipe Ø 4 mm - M5 - G 1/8
Nominal diameter	2,5 mm
Controls	
Mechanical	Plunger; roller lever; unidirectional roller lever
Manual	Tapper; actuators for panel mounting

MATERIALS

Body	Anodized aluminium alloy
Bushing and guide	Nickel - plated brass
Springs	Stainless steel
Seals	NBR rubber
Connections	Nickel - plated brass, plastic material
Controls	
Tapper; Swivel	Glass stiffened polyamide
Plunger; Roller	Nickel - plated brass
Lever	Steel



FLOW CHART - M

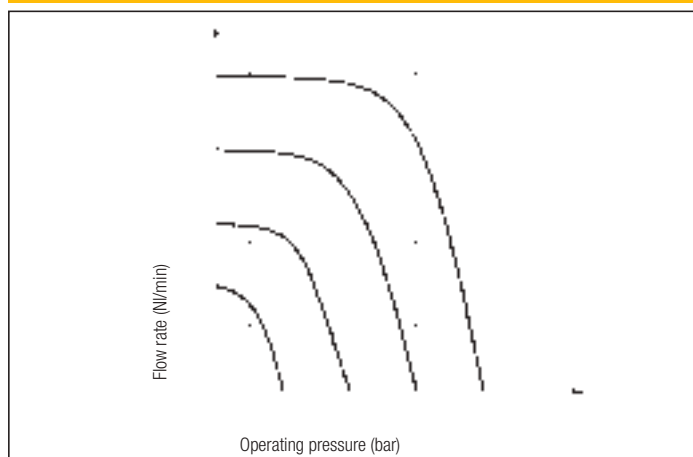

2 AND 3 PORT N.C. - N.O.

Symbol	Function	Controls		Actuation force at 6 bar (N)	Flow rate at 6 bar ΔP = 1 bar (Nl/min)	Weight (g)	Port size	TYPE*
		Pilot	Return					
	2/2 N.O. monostable	Plunger	Mechanical spring	13	83	40	Ø4 bottom ported Ø4 side ported M5 bottom threaded M5 side threaded G 1/8 bottom ported	MHAS4 MHAS4/L MHASM5 MHASM5/L MHAS1/8
	2/2 N.C. monostable	Plunger	Mechanical spring	13	83	40	Ø4 bottom ported Ø4 side ported M5 bottom threaded M5 side threaded G 1/8 bottom ported	MHCS4 MHCS4/L MHCSM5 MHCSM5/L MHCS1/8
	3/2 N.O. monostable	Plunger	Mechanical spring	13	83	40	Ø4 bottom ported Ø4 side ported M5 bottom threaded M5 side threaded G 1/8 bottom ported	MAS4 MAS4/L MASM5 MASM5/L MAS1/8
	3/2 N.C. monostable	Plunger	Mechanical spring	13	83	40	Ø4 bottom ported Ø4 side ported M5 bottom threaded M5 side threaded G 1/8 bottom ported	MCS4 MCS4/L MCSM5 MCSM5/L MCS1/8
	2/2 N.O. monostable	Plunger for panel mounting	Mechanical spring	13	83	60	Ø4 bottom ported Ø4 side ported M5 bottom threaded M5 side threaded G 1/8 bottom ported	MHAP4 MHAP4/L MHAPM5 MHAPM5/L MHAP1/8
	2/2 N.C. monostable	Plunger for panel mounting	Mechanical spring	13	83	60	Ø4 bottom ported Ø4 side ported M5 bottom threaded M5 side threaded G 1/8 bottom ported	MHCP4 MHCP4/L MHCPM5 MHCPM5/L MHCP1/8
	3/2 N.O. monostable	Plunger for panel mounting	Mechanical spring	13	83	60	Ø4 bottom ported Ø4 side ported M5 bottom threaded M5 side threaded G 1/8 bottom ported	MAP4 MAP4/L MAPM5 MAPM5/L MAP1/8

*EX Consistent with the ATEX directive II 2GD c T5 T100°C -20°C ≤ Ta ≤ 60°C

E.G.: MCS4/EX

2 AND 3 PORT N.C. - N.O.

Symbol	Function	Controls		Actuation force at 6 bar (N)	Flow rate at 6 bar $\Delta P = 1$ bar (NI/min)	Weight (g)	Port size	TYPE*
		Pilot	Return					
	3/2 N.C. monostable	Plunger for panel mounting	Mechanical spring	13	83	60	Ø4 bottom ported Ø4 side ported M5 bottom threaded M5 side threaded G 1/8 bottom ported	MCP4 MCP4/L MCPM5 MCPM5/L MCP1/8
	2/2 N.O. monostable	Roller lever	Mechanical spring	7	83	50	Ø4 bottom ported Ø4 side ported M5 bottom threaded M5 side threaded G 1/8 bottom ported	MHALR4 MHALR4/L MHALRM5 MHALRM5/L MHALR1/8
	2/2 N.C. monostable	Roller lever	Mechanical spring	7	83	50	Ø4 bottom ported Ø4 side ported M5 bottom threaded M5 side threaded G 1/8 bottom ported	MHCLR4 MHCLR4/L MHCLRM5 MHCLRM5/L MHCLR1/8
	3/2 N.O. monostable	Roller lever	Mechanical spring	7	83	50	Ø4 bottom ported Ø4 side ported M5 bottom threaded M5 side threaded G 1/8 bottom ported	MALR4 MALR4/L MALRM5 MALRM5/L MALR1/8
	3/2 N.C. monostable	Roller lever	Mechanical spring	7	83	50	Ø4 bottom ported Ø4 side ported M5 bottom threaded M5 side threaded G 1/8 bottom ported	MCLR4 MCLR4/L MCLRM5 MCLRM5/L MCLR1/8
	2/2 N.O. monostable	Unidirectional roller lever	Mechanical spring	7	83	50	Ø4 bottom ported Ø4 side ported M5 bottom threaded M5 side threaded G 1/8 bottom ported	MHALRU4 MHALRU4/L MHALRUM5 MHALRUM5/L MHALRU1/8
	2/2 N.C. monostable	Unidirectional roller lever	Mechanical spring	7	83	50	Ø4 bottom ported Ø4 side ported M5 bottom threaded M5 side threaded G 1/8 bottom ported	MHCLRU4 MHCLRU4/L MHCLRUM5 MHCLRUM5/L MHCLRU1/8
	3/2 N.O. monostable	Unidirectional roller lever	Mechanical spring	7	83	50	Ø4 bottom ported Ø4 side ported M5 bottom threaded M5 side threaded G 1/8 bottom ported	MALRU4 MALRU4/L MALRUM5 MALRUM5/L MALRU1/8
	3/2 N.C. monostable	Unidirectional roller lever	Mechanical spring	7	83	50	Ø4 bottom ported Ø4 side ported M5 bottom threaded M5 side threaded G 1/8 bottom ported	MCLRU4 MCLRU4/L MCLRUM5 MCLRUM5/L MCLRU1/8
	2/2 N.O. monostable	Tapper	Mechanical spring	7	83	50	Ø4 bottom ported Ø4 side ported M5 bottom threaded M5 side threaded G 1/8 bottom ported	MHAT4 MHAT4/L MHATM5 MHATM5/L MHAT1/8
	2/2 N.C. monostable	Tapper	Mechanical spring	7	83	50	Ø4 bottom ported Ø4 side ported M5 bottom threaded M5 side threaded G 1/8 bottom ported	MHCT4 MHCT4/L MHCTM5 MHCTM5/L MHCT1/8
	3/2 N.O. monostable	Tapper	Mechanical spring	7	83	50	Ø4 bottom ported Ø4 side ported M5 bottom threaded M5 side threaded G 1/8 bottom ported	MAT4 MAT4/L MATM5 MATM5/L MAT1/8
	3/2 N.C. monostable	Tapper	Mechanical spring	7	83	50	Ø4 bottom ported Ø4 side ported M5 bottom threaded M5 side threaded G 1/8 bottom ported	MCT4 MCT4/L MCTM5 MCTM5/L MCT1/8

*EX Consistent with the ATEX directive II 2GD c T5 T100°C -20°C ≤ Ta ≤ 60°C E.G.: MCLR4/EX

3

PLUNGER - Ø 4 mm SIDE AND BOTTOM PORTED

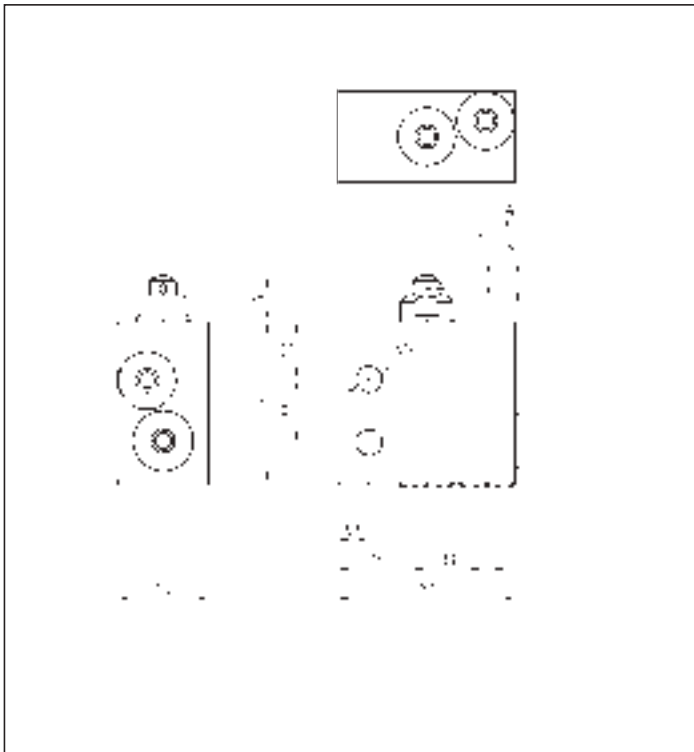

P.S.: DO NOT EXCEED THE MAXIMUM ACTUATION STROKE

PLUNGER - M5 THREADED CONNECTIONS SIDE AND BOTTOM PORTED - G 1/8 BOTTOM PORTED

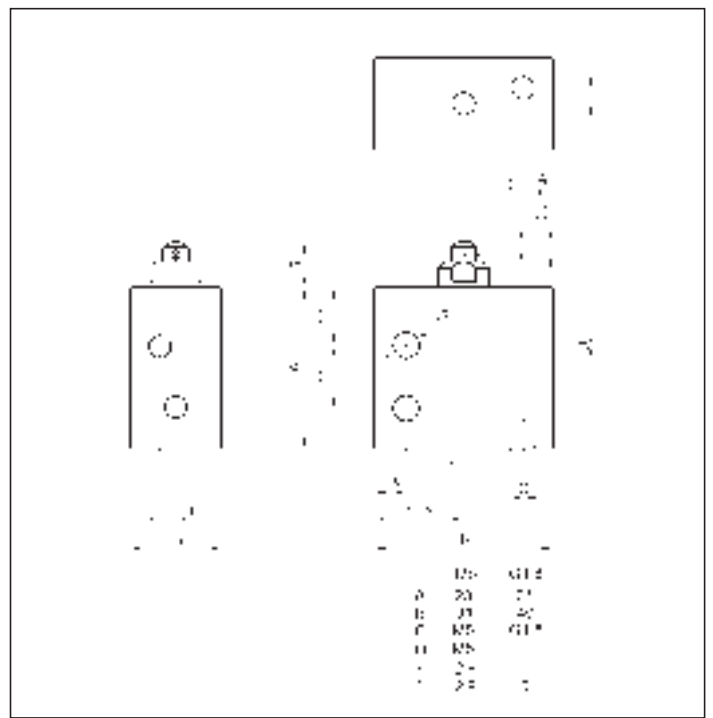

P.S.: DO NOT EXCEED THE MAXIMUM ACTUATION STROKE

CONTROLS

PLUNGER FOR PANEL MOUNTING

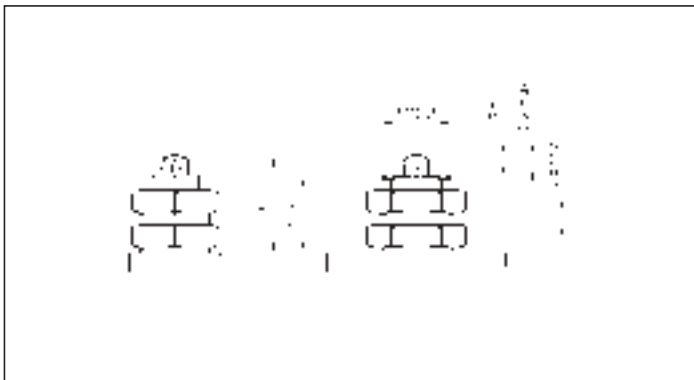

P.S.: DO NOT EXCEED THE MAXIMUM ACTUATION STROKE

ROLLER LEVER

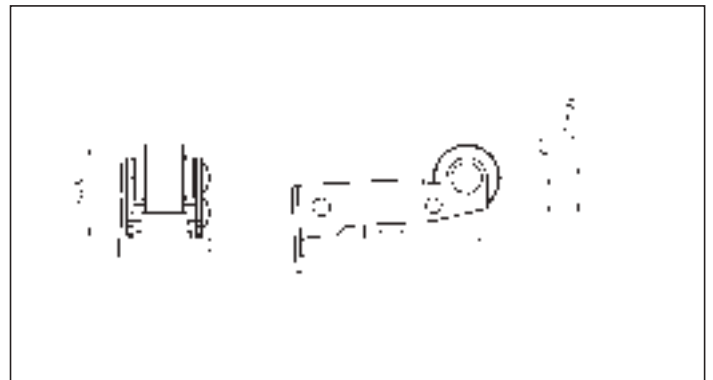

UNIDIRECTIONAL ROLLER LEVER

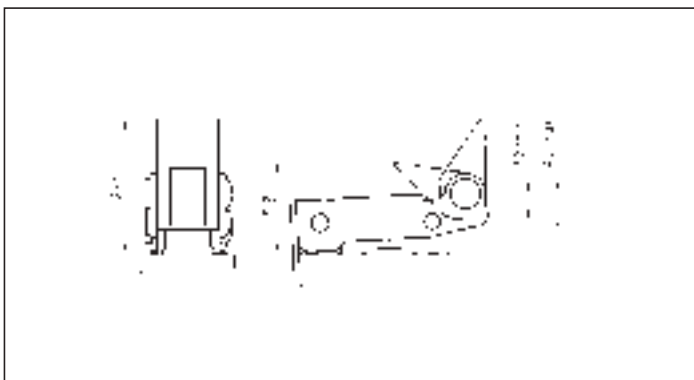

TAPPER

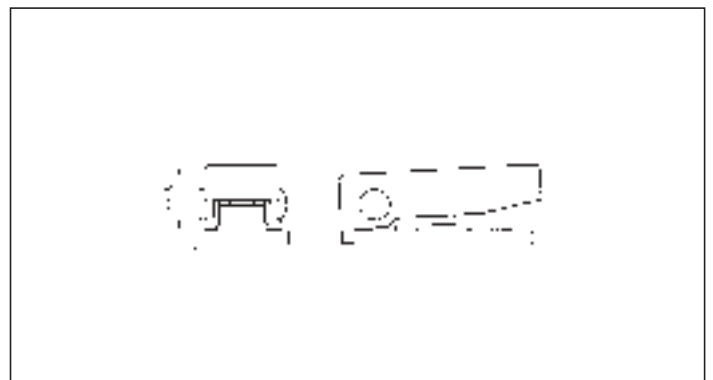

ACTUATORS FOR PANEL MOUNTING

Symbol	Description	Function	TYPE	Symbol	Description	Function	TYPE
	Protected monostable push-button BLACK RED GREEN	0 ← 1	MCS - PMN MCS - PMR MCS - PMV	⋅	Black bistable short-lever switch	0 1	MCS - LCB
⋅	Red monostable mushroom	0 ← 1	MCS - FMR	⋅	Black monostable short-lever switch, 3 position with return to the centre	1 → 0 ← 2	MCS - LCSM
⋅⋅	Red bistable mushroom (rotate to unlock)	0 1	MCS - FBR	⋅	Black short-lever switch, 3 stable positions	1 0 2	MCS - LCSB
	Black monostable short-lever switch	0 ← 1	MCS - LCM	⋅	Bistable key (extractable in both the 2 positions)	0 1	MCS - CB2

ADAPTER TYPE MCS-SA FOR ACTUATORS

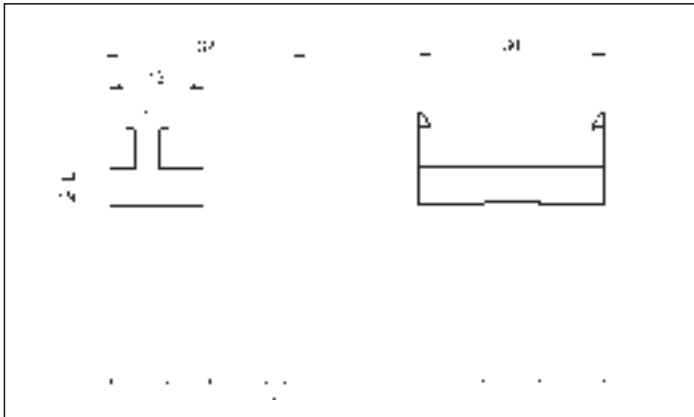

DOUBLE ADAPTER TYPE MCS-SAD FOR ACTUATORS

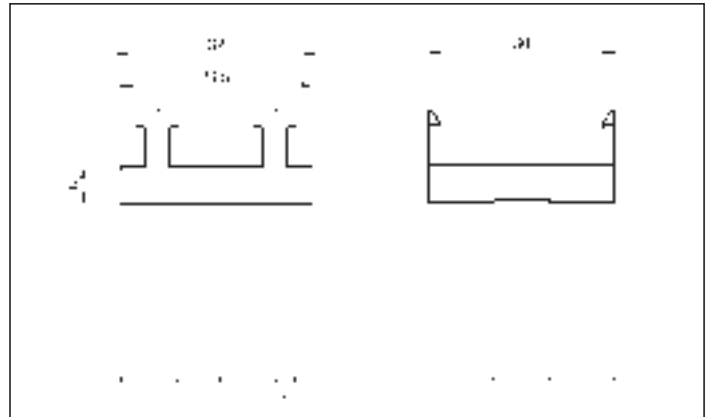

PUSH-BUTTON

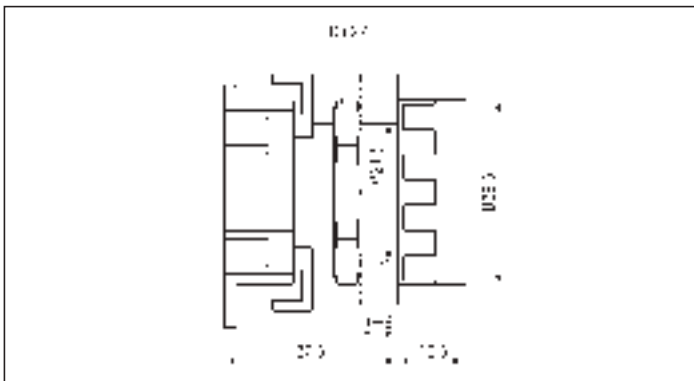

MUSHROOM

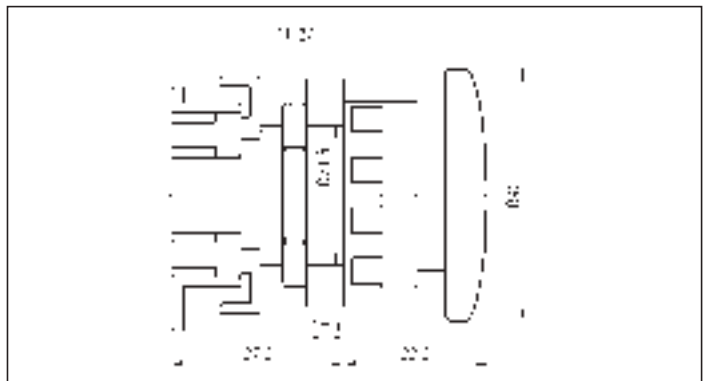

SHORT - LEVER SWITCH

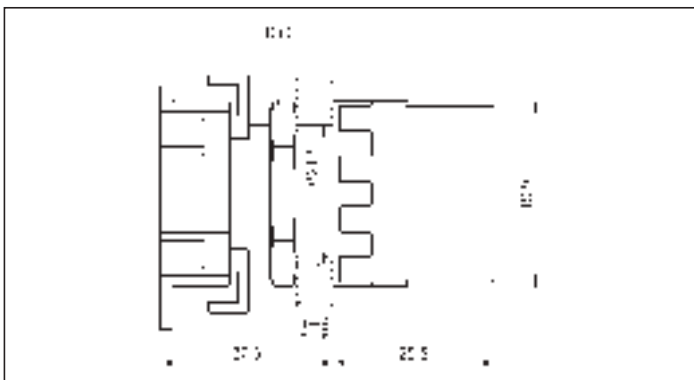

BISTABLE KEY

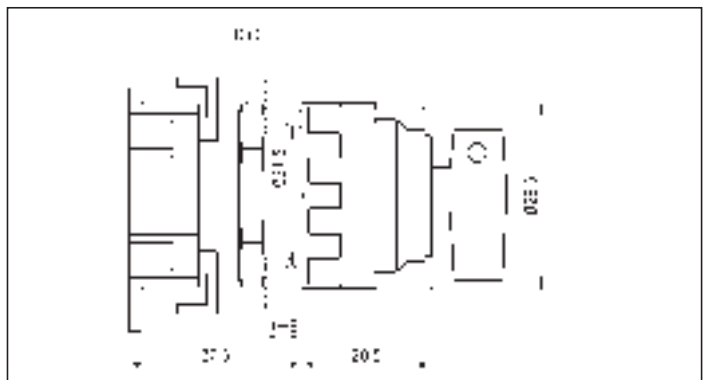

DESCRIPTION

Valves series "EK" are produced in the 3/2, 5/2 and 5/3 pneumatic functions; the kind of construction is based on a balanced spool. In the mechanically actuated version these valves are available only for the size G 1/8 and G 1/4, while the manually actuated versions are available in the different sizes and they are suitable for panel mounting (except for size G 1/2). They are in compliance with ATEX directive, 2GD category, upon request.

TECHNICAL DATA

Operating pressure	0 ÷ 10 bar direct actuation 3 ÷ 10 bar assisted actuation
Working temperature	0 ÷ +60 °C (-20 °C with dry air)
Fluid	Compressed air, filtered, continuous lubricated, unlubricated or dry lubricated
Port size	G 1/8 - G 1/4 - G 1/2
Nominal diameter	G 1/8 = 5 mm G 1/4 = 8 mm G 1/2 = 12 mm
Controls	
Mechanical	Plunger; roller lever; whisker; released pressure key
Manual	Drawer; front lever; lateral knob; actuators for panel mounting (see on page 3.5)

SPARE PARTS

SEALS KIT	
3 port G 1/8	EK/M/SG/8
5 port G 1/8	EKCA/M/SG/8
3 port G 1/4	EK/M/SG/4
5 port G 1/4	EKCA/M/SG/4
5 port G 1/2	EKCA/M/SG/2

FLOW CHART - EK G 1/8 - 5/2

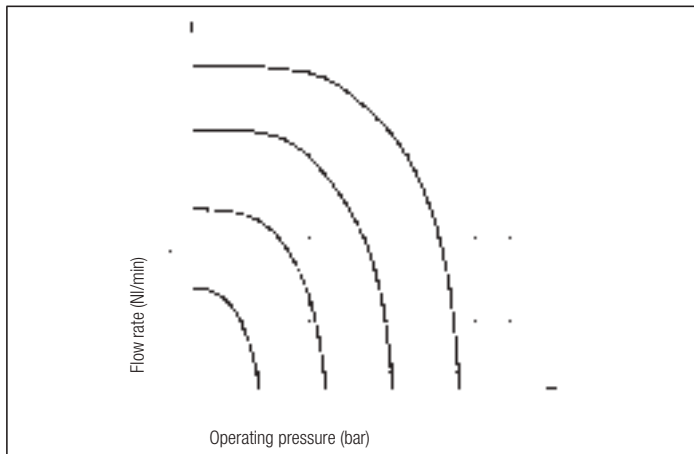

FLOW CHART - EK G 1/2 - 5/2

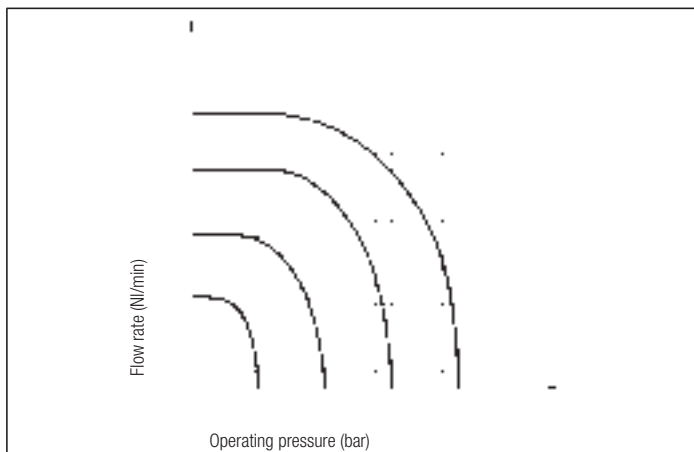

MATERIALS

Bottoms	Front: aluminium alloy or plastic - Rear: aluminium alloy
Body	Anodized aluminium alloy
Distance rings	Acetal resin
Springs	Galvanized steel
Seals	NBR rubber
Spool	Anodized aluminium alloy
Controls	
Lever; Ball	Steel
Plunger	Brass
Whisker	Stainless steel
Released pressure key	Anodized aluminium alloy
Bellows	Elastomer
Knobs; Handgrips	Plastic material
Roller	Ball bearing (plastic material upon request)

FLOW CHART - EK G 1/4 - 5/2

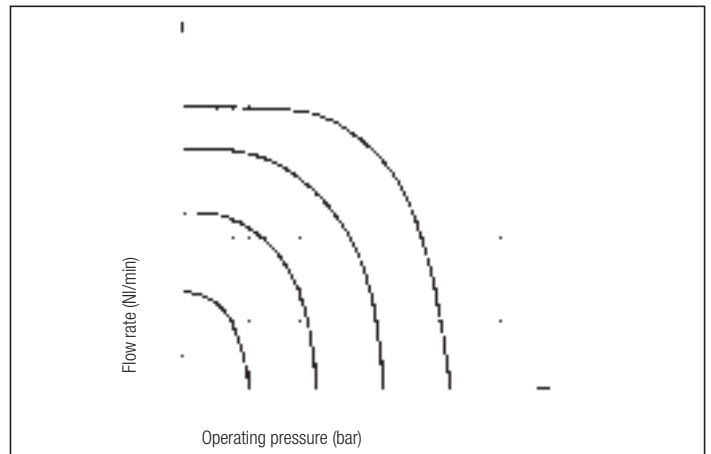

MECHANICALLY ACTUATED VALVES G 1/8

Symbol	Function	Controls		Actuation force at 6 bar (N)	Flow rate at 6 bar $\Delta P = 1$ bar (NI/min)	Weight (g)	TYPE*
		Pilot	Return				
	3/2 N.O. monostable	Plunger	Mechanical spring	32	390	135	EK8/PS
	3/2 N.C. monostable						
	3/2 bistable	Plunger	Plunger	32	390	140	EK8/PSS
	5/2 monostable	Plunger	Mechanical spring	32	490	165	EKCA8/PS
	5/2 bistable	Plunger	Plunger	32	490	170	EKCA8/PSS
	3/2 N.O. monostable	Roller lever	Mechanical spring	15	390	160	EK8/LR
	3/2 N.C. monostable						
	3/2 bistable	Roller lever	Roller lever	15	390	200	EK8/LRLR
	5/2 monostable	Roller lever	Mechanical spring	15	490	190	EKCA8/LR
	5/2 bistable	Roller lever	Roller lever	15	490	225	EKCA8/LRLR
	3/2 N.O. monostable	Piloted whisker (sensitive)	Mechanical spring	1,5	420	230	EKA8/A
	3/2 N.C. monostable						EKC8/A
	5/2 monostable	Piloted whisker (sensitive)	Mechanical spring	1,5	490	260	EKCA8/A
	3/2 N.O. monostable	Piloted released pressure key (sensitive)	Mechanical spring	1,5	420	210	EKA8/TD
	3/2 N.C. monostable						EKC8/TD
	5/2 monostable	Piloted released pressure key (sensitive)	Mechanical spring	1,5	490	230	EKCA8/TD
	3/2 N.O. monostable	Piloted plunger for panel mounting (sensitive)	Mechanical spring	1,5	420	230	EKA8/Q
	3/2 N.C. monostable						EKC8/Q
	5/2 monostable	Piloted plunger for panel mounting (sensitive)	Mechanical spring	1,5	490	260	EKCA8/Q

P.S.: ADD THE LETTER "U" TO THE TYPE TO ORDER THE UNIDIRECTIONAL ROLLER VALVES - E.G.: **EKCA8/LRLRU**
 ADD THE LETTER "N" TO THE TYPE TO ORDER THE VALVES WITH PLASTIC ROLLER - E.G.: **EK8/LRN**

*EX Consistent with the ATEX directive II 2GD c T5 T100°C -20°C ≤ Ta ≤ 60°C E.G.: **EK8/PSS/EX**

EK8/PS

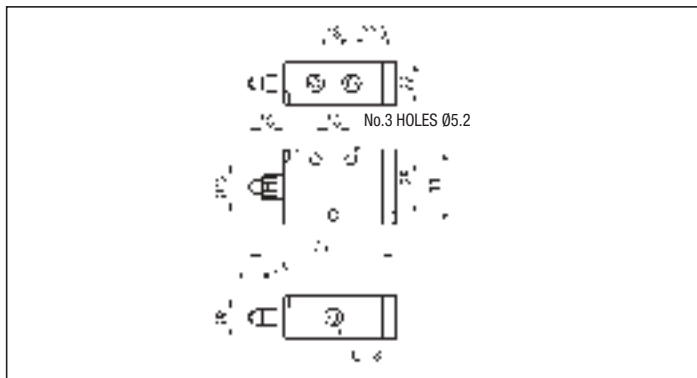

EK8/PSS

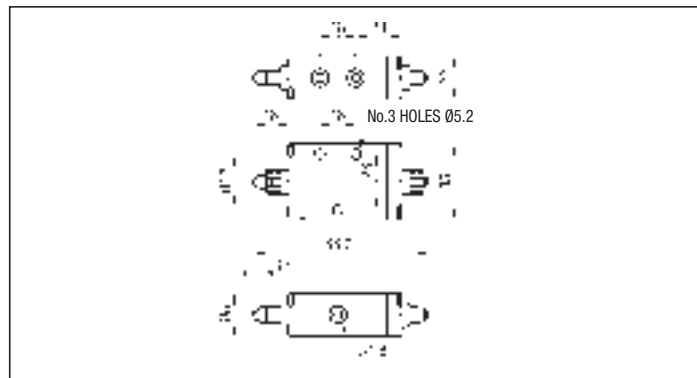

EKCA8/PS

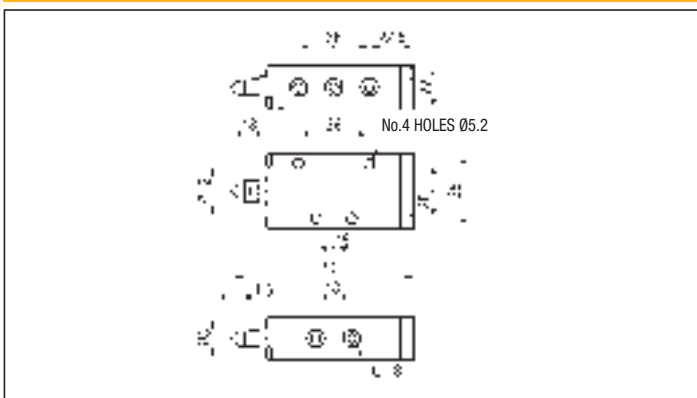

EKCA8/PSS

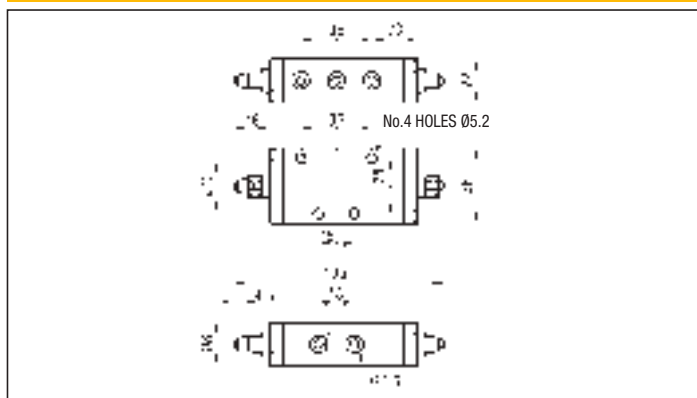

EK8/LR*

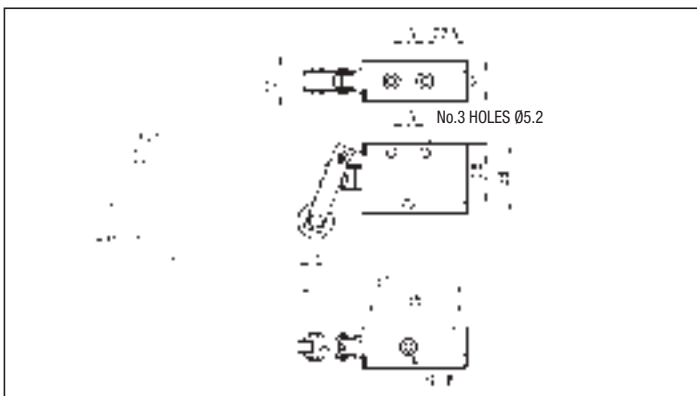

EK8/LRLR*

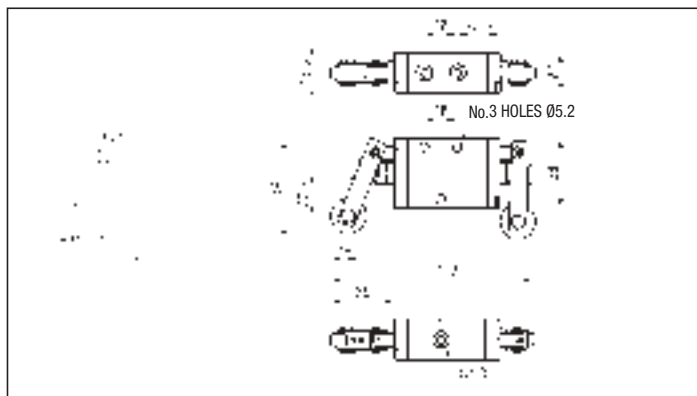

EKCA8/LR*

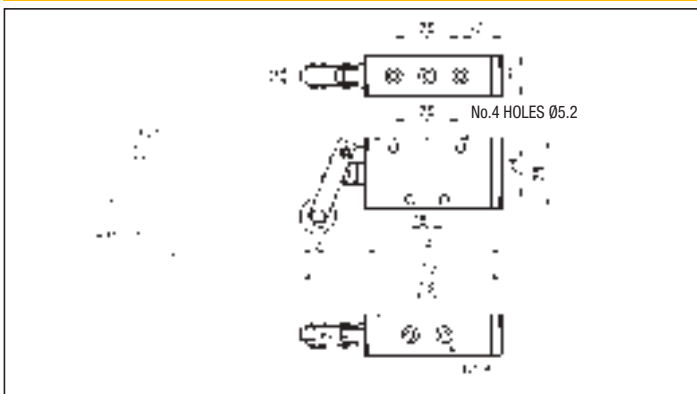

EKCA8/LRLR*

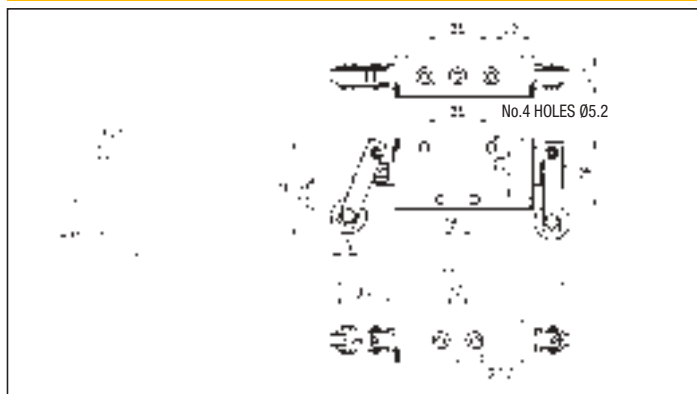

* - ADD THE LETTER "U" TO THE TYPE TO ORDER THE UNIDIRECTIONAL ROLLER VALVES - E.G.: **EKCA8/LRLRU**
 - ADD THE LETTER "N" TO THE TYPE TO ORDER THE VALVES WITH PLASTIC ROLLER - E.G.: **EK8/LRN**

EKA8/A - EKC8/A

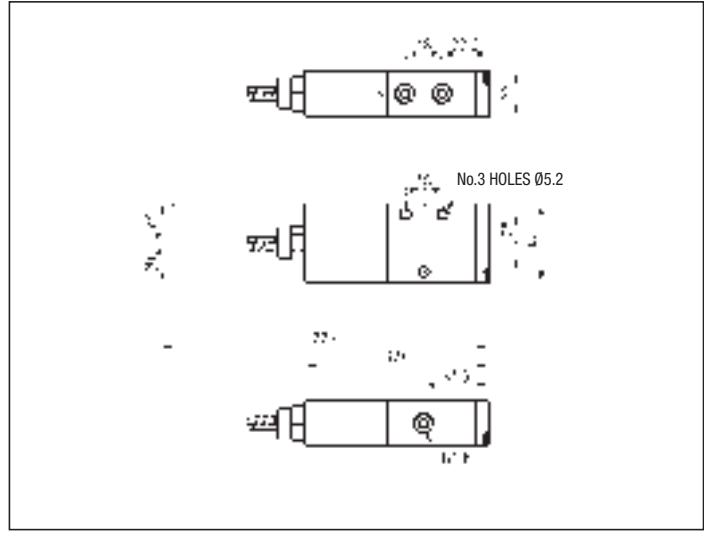

EKCA8/A

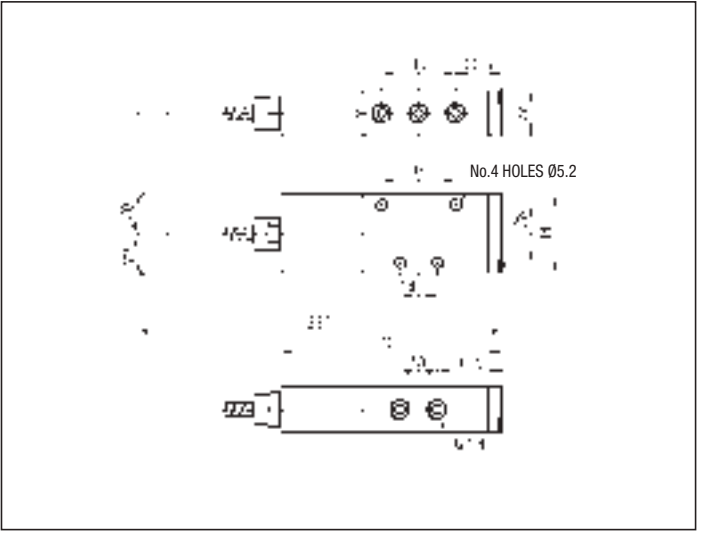

EKA8/TD - EKC8/TD*

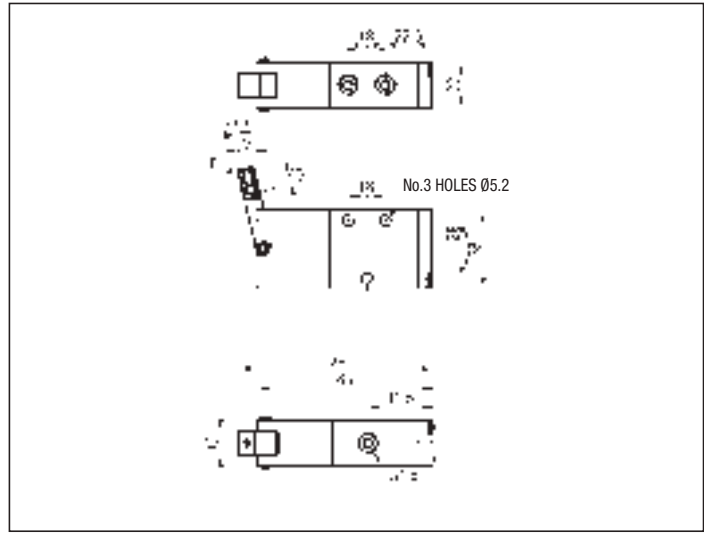

EKCA8/TD*

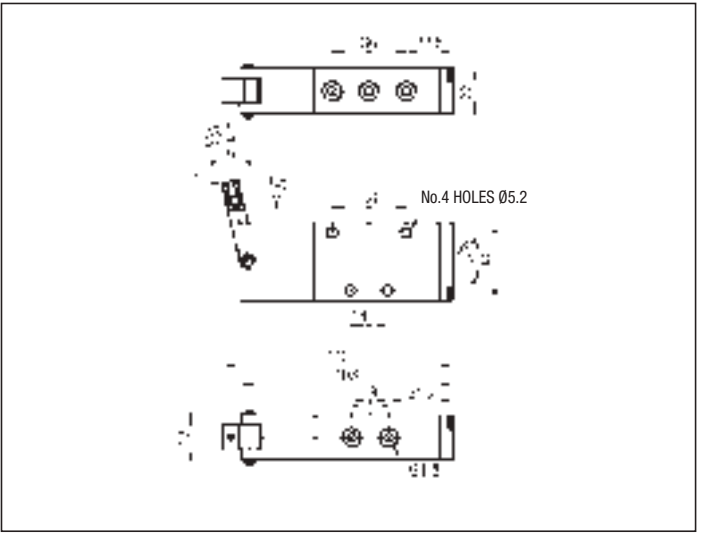

* IT IS POSSIBLE TO INCREASE THE SENSITIVITY OF THE KEY USING A Ø 3 mm EXTENSION ON THE SAME KEY

* IT IS POSSIBLE TO INCREASE THE SENSITIVITY OF THE KEY USING A Ø 3 mm EXTENSION ON THE SAME KEY

EKC8/Q - EKA8/Q

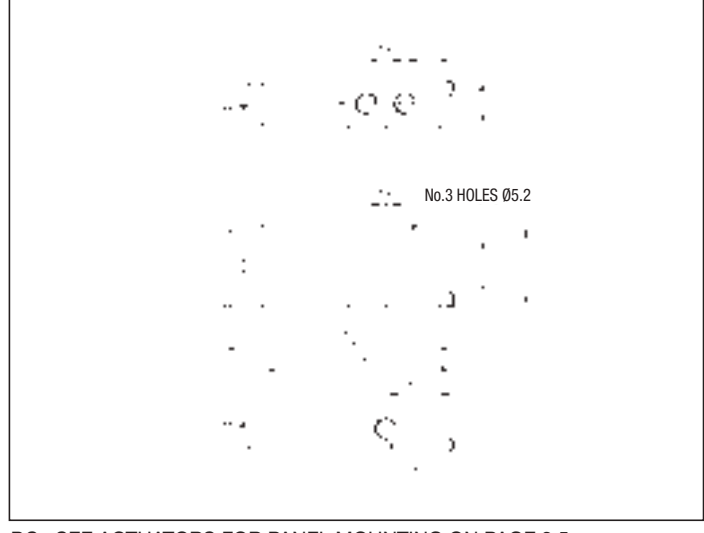

EKCA8/Q

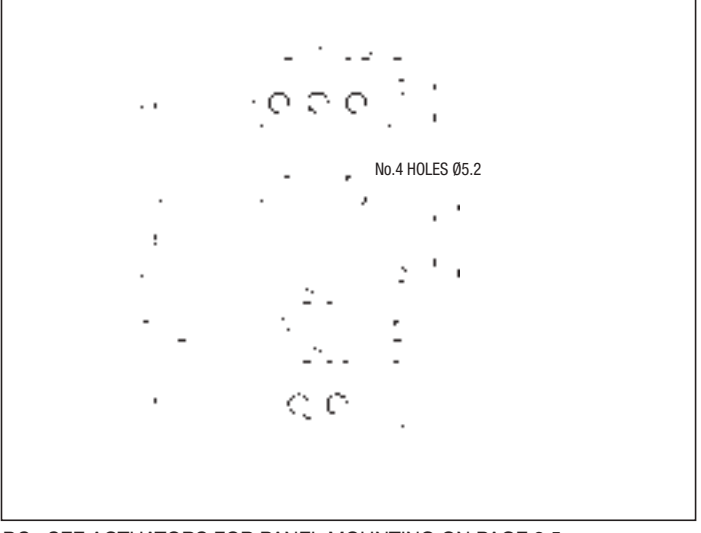

P.S.: SEE ACTUATORS FOR PANEL MOUNTING ON PAGE 3.5

P.S.: SEE ACTUATORS FOR PANEL MOUNTING ON PAGE 3.5

3

MANUALLY ACTUATED VALVES G 1/8

Symbol	Function	Controls		Flow rate at 6 bar $\Delta P = 1 \text{ bar (Nl/min)}$	Weight (g)	TYPE*
		Pilot	Return			
	3/2 N.O. monostable	Push rod button	Mechanical spring	480	155	EK8/T
	3/2 N.C. monostable					
	3/2 bistable	Drawer	Drawer	480	155	EK8/TF
	5/2 monostable	Push rod button	Mechanical spring	480	185	EKCA8/T
	5/2 bistable	Drawer	Drawer	480	185	EKCA8/TF
	3/2 N.O. monostable	Front lever	Mechanical spring	480	150	EK8/MV
	3/2 N.C. monostable					
	3/2 bistable	Front lever	Front lever	480	150	EK8/MVF
	5/2 monostable	Front lever	Mechanical spring	480	185	EKCA8/MV
	5/2 bistable	Front lever	Front lever	480	185	EKCA8/MVF
	3/2 N.O. monostable	Lateral knob	Mechanical spring	480	155	EK8/M
	3/2 N.C. monostable					
	3/2 bistable	Lateral knob	Lateral knob	480	185	EK8/MF
	5/2 monostable	Lateral knob	Mechanical spring	480	205	EKCA8/M
	5/2 bistable	Lateral knob	Lateral knob	480	205	EKCA8/MF
	5/3 monostable closed centre	Lateral knob	Mechanical spring	300	205	EKCA8/MS
	5/3 stable closed centre	Lateral knob	Lateral knob	300	205	EKCA8/MSF
	5/3 monostable open centre	Lateral knob	Mechanical spring	300	205	EKCA8/MA
	5/3 stable open centre	Lateral knob	Lateral knob	300	205	EKCA8/MAF

*/EX Consistent with the ATEX directive II 2GD c T5 T100°C -20°C ≤ Ta ≤ 60°C E.G.: EK8/M/EX

MANUALLY ACTUATED VALVES G 1/8

Symbol	Function	Controls		Flow rate at 6 bar $\Delta P = 1 \text{ bar (Nl/min)}$	Weight (g)	TYPE*
		Pilot	Return			
	3/2 bistable	Selector	Selector	480	240	EK8/SLF
	5/2 bistable	Selector	Selector	480	260	EKCA8/SLF

*EX Consistent with the ATEX directive II 2GD c T5 T100°C -20°C ≤ Ta ≤ 60°C E.G.: **EK8/M/EX**

EK8/T - EK8/TF

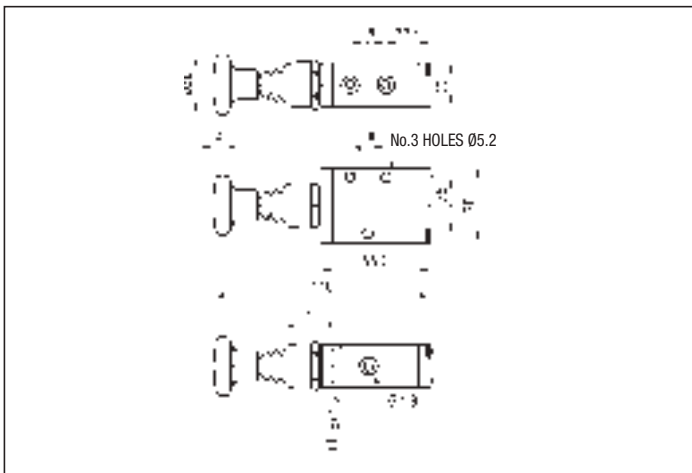

EKCA8/T - EKCA8/TF

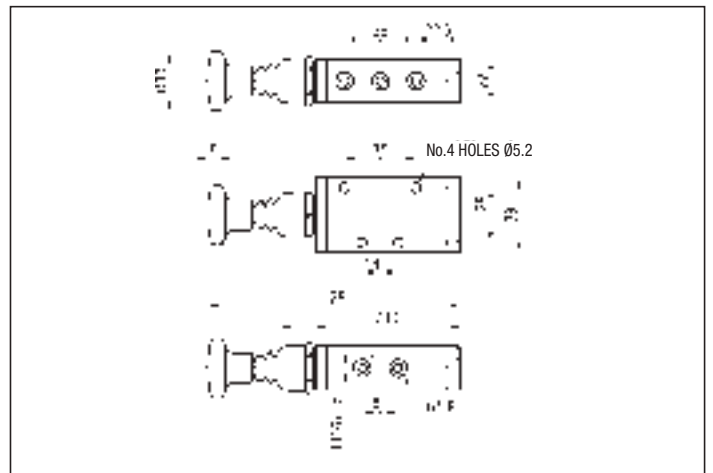

EK8/MV - EK8/MVF

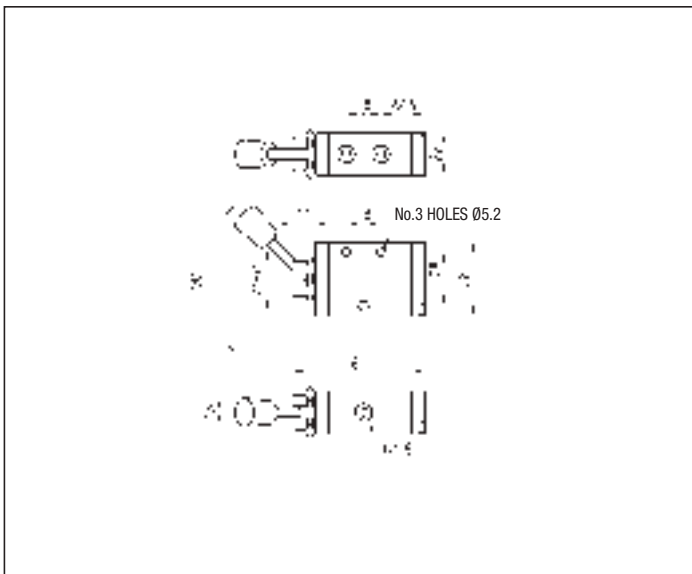

EKCA8/MV - EKCA8/MVF

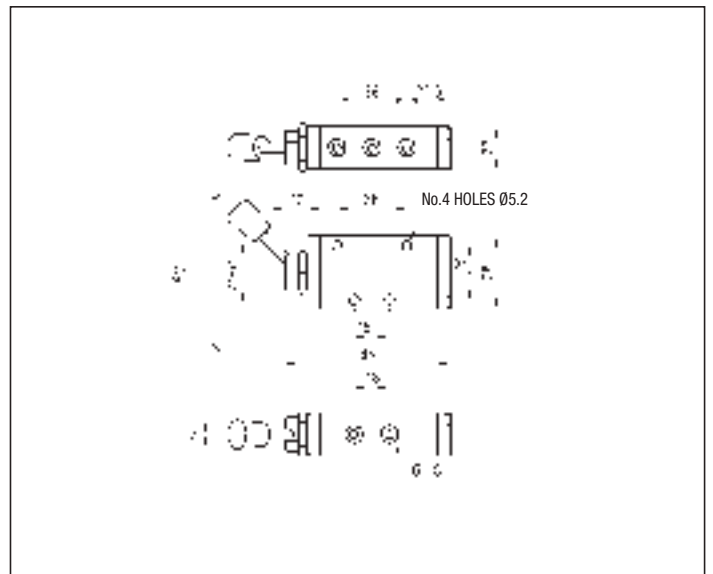

3

EK8/M - EK8/MF

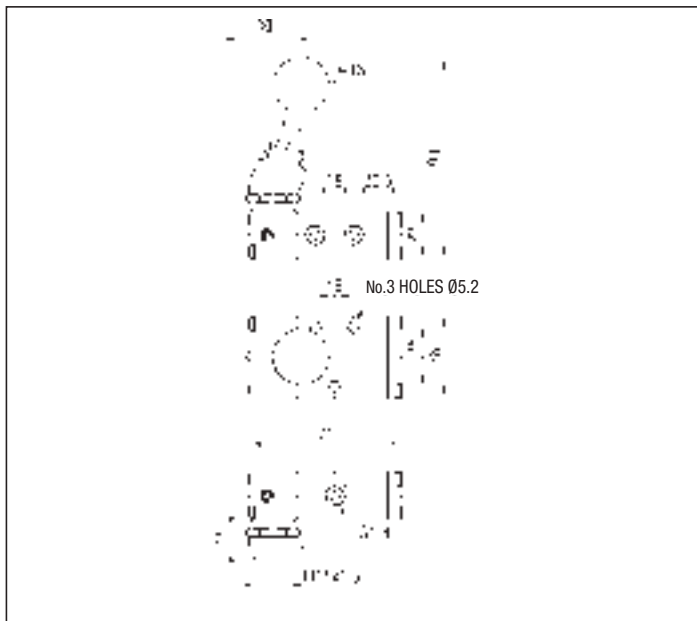

5/2 - 5/3 LATERAL KNOB

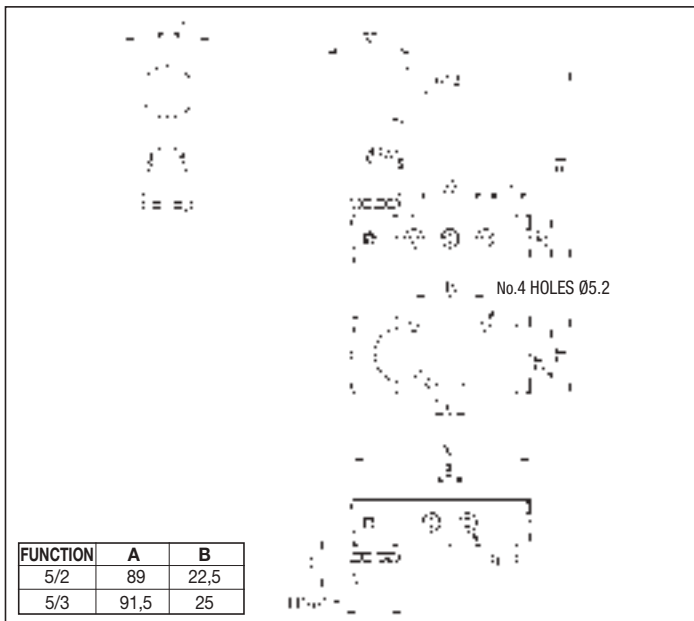

EK8/SLF

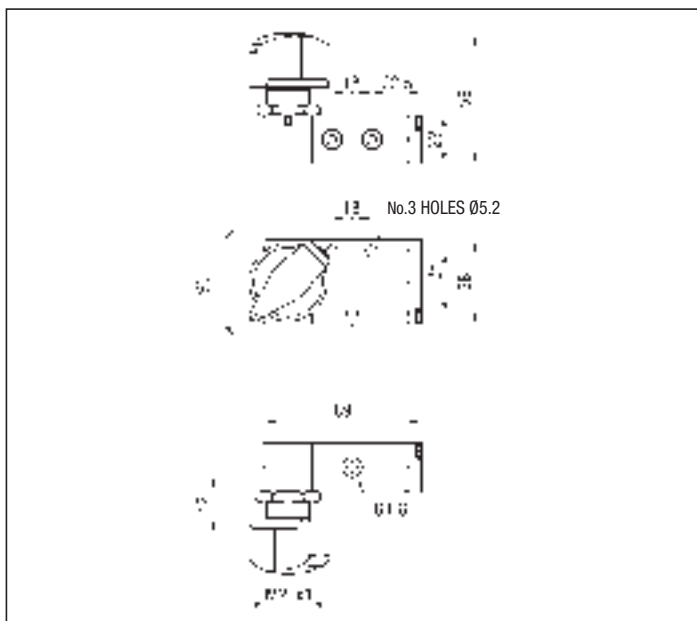

EKCA8/SLF

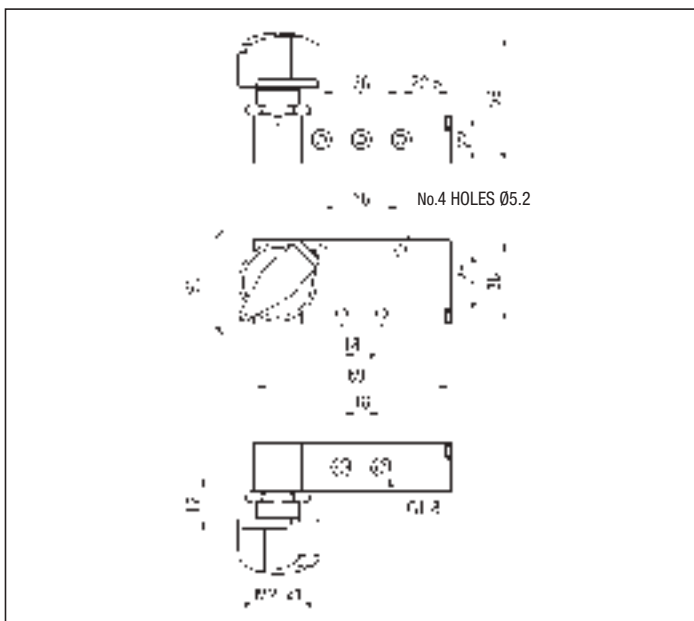

MECHANICALLY ACTUATED VALVES G 1/4

Symbol	Function	Controls		Actuation force at 6 bar (N)	Flow rate at 6 bar $\Delta P = 1$ bar (NI/min)	Weight (g)	TYPE*
		Pilot	Return				
	3/2 N.O. monostable	Drawer	Mechanical spring	51	900	205	EK4/PS
	3/2 N.C. monostable						
	3/2 bistable	Drawer	Drawer	9,5	900	200	EK4/PSS
	5/2 monostable	Drawer	Mechanical spring	51	900	250	EKCA4/PS
	5/2 bistable	Drawer	Drawer	9,5	900	250	EKCA4/PSS
	3/2 N.O. monostable	Front lever	Mechanical spring	21	900	270	EK4/LR
	3/2 N.C. monostable						
	3/2 bistable	Front lever	Front lever	16	900	325	EK4/LRLR
	5/2 monostable	Front lever	Mechanical spring	21	900	320	EKCA4/LR
	5/2 bistable	Front lever	Front lever	16	900	380	EKCA4/LRLR

P.S.: ADD THE LETTER "N" TO THE TYPE TO ORDER THE VALVES WITH PLASTIC ROLLER - E.G.: **EK4/LRN**

*/EX Consistent with the ATEX directive II 2GD c T5 T100°C -20°C≤T_a≤60°C E.G.: **EK4/PSS/EX**

EK4/PS

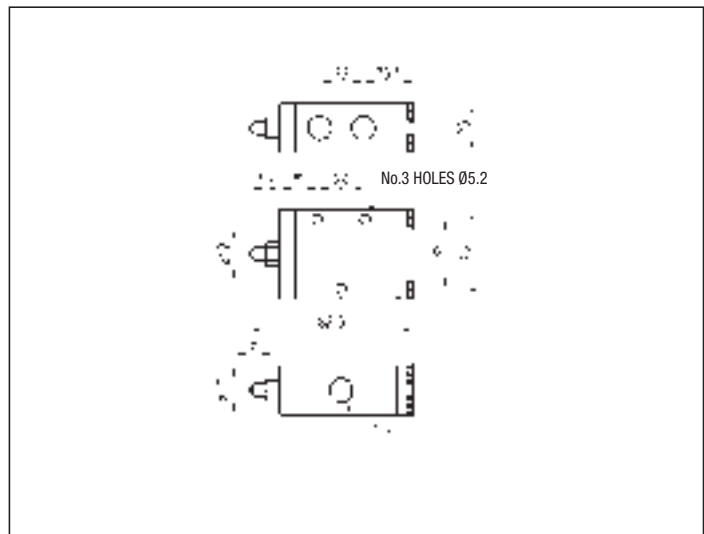

EK4/PSS

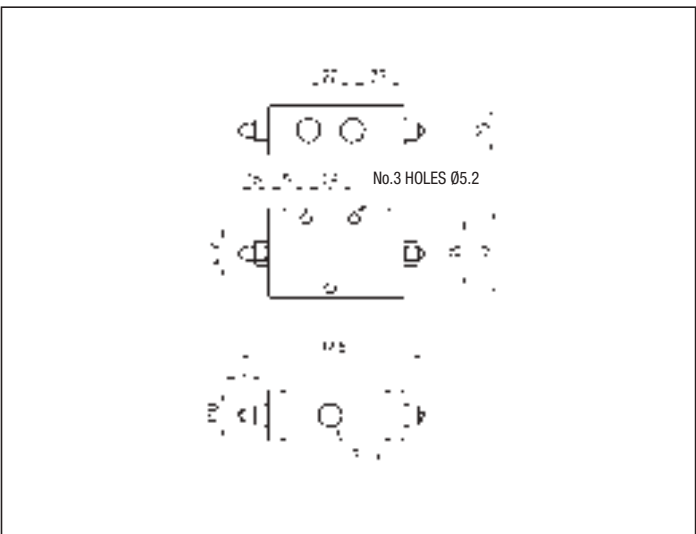

3

EKCA4/PS

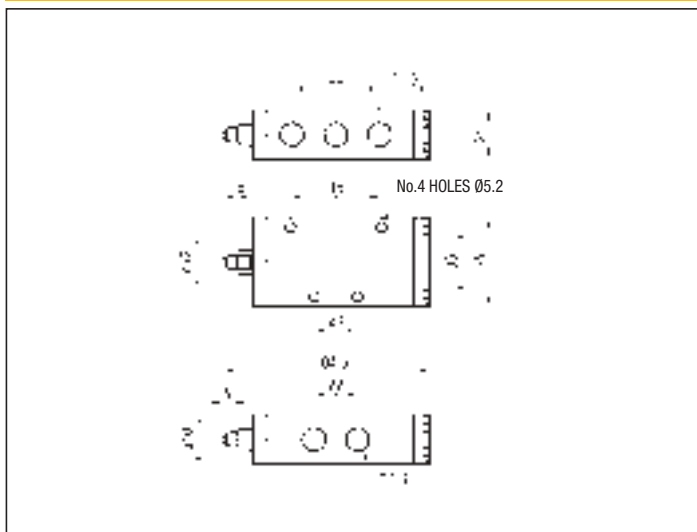

EKCA4/PSS

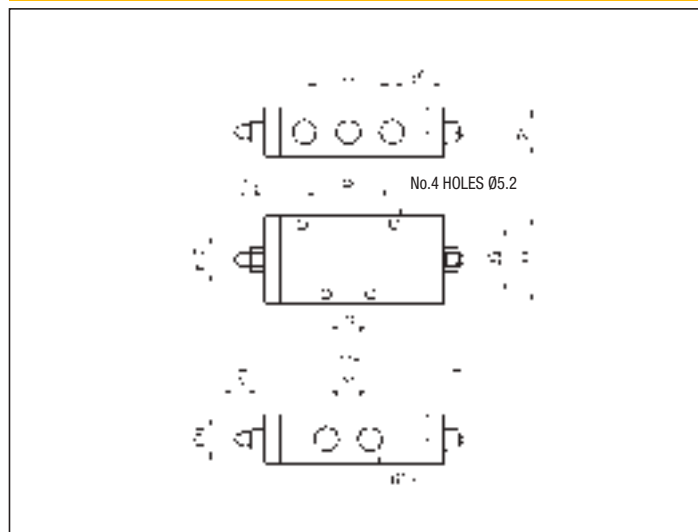

EK4/LR*

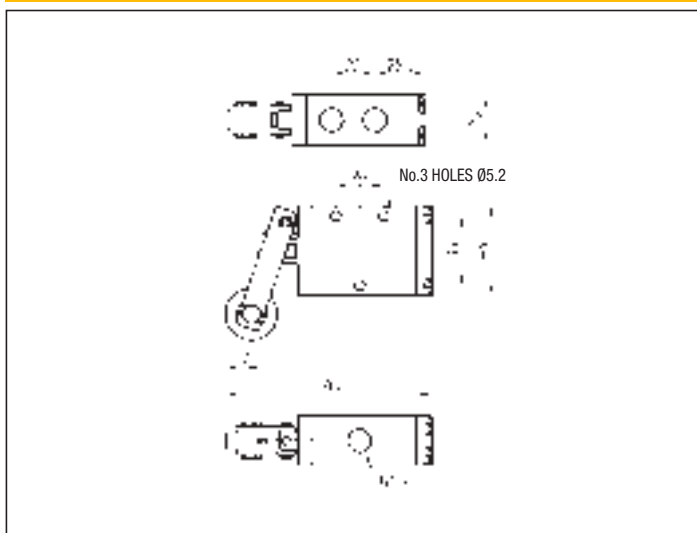

EK4/LRLR*

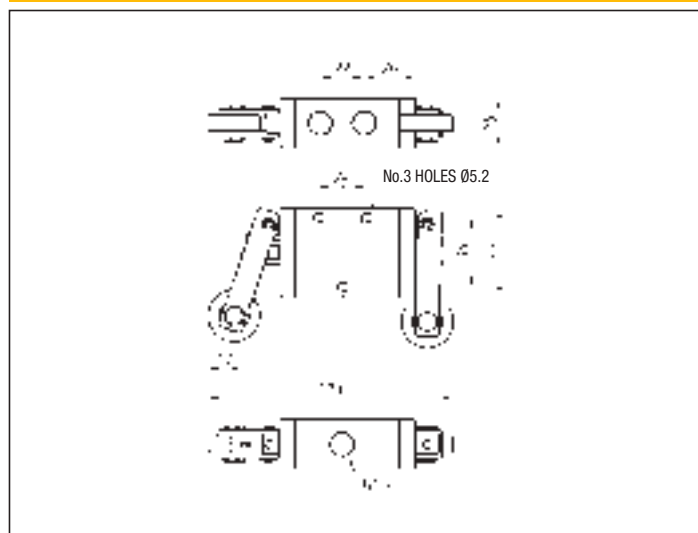

EKCA4/LR*

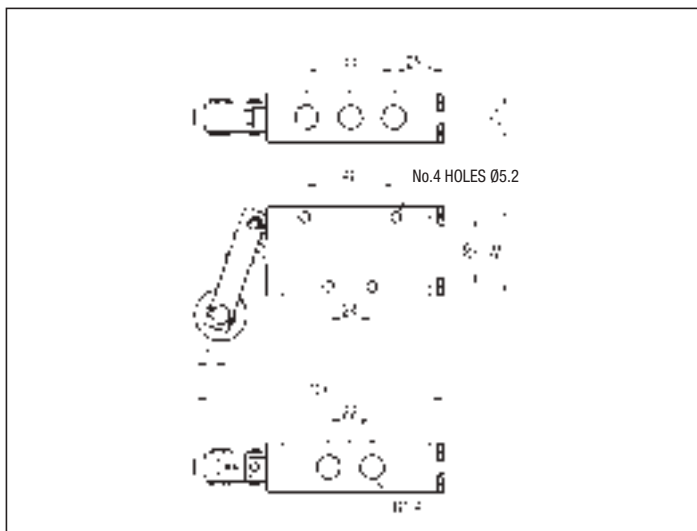

EKCA4/LRLR*

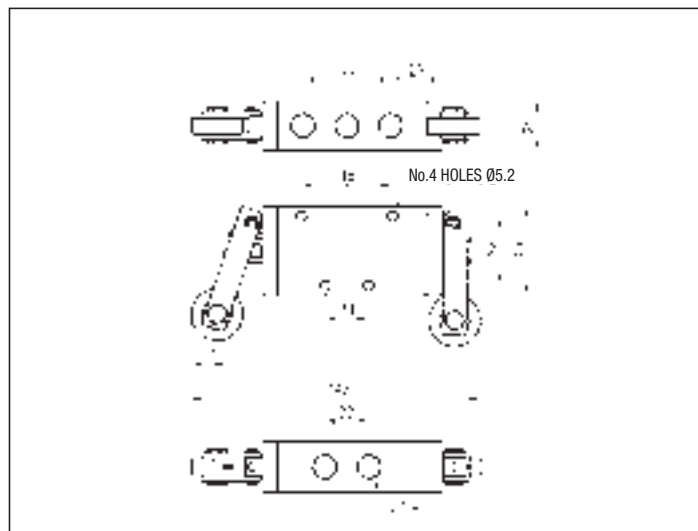

* P.S.: ADD THE LETTER "N" TO THE TYPE TO ORDER THE VALVES WITH PLASTIC ROLLER - E.G.: EK4/LRN

MANUALLY ACTUATED VALVES G 1/4

Symbol	Function	Controls		Flow rate at 6 bar $\Delta P = 1 \text{ bar (l/min)}$	Weight (g)	TYPE*
		Pilot	Return			
	3/2 N.O. monostable	Push rod button	Mechanical spring	900	240	EK4/T
	3/2 N.C. monostable					
	3/2 bistable	Drawer	Drawer	900	240	EK4/TF
	5/2 monostable	Push rod button	Mechanical spring	900	305	EKCA4/T
	5/2 bistable	Drawer	Drawer	900	305	EKCA4/TF
	3/2 N.O. monostable	Front lever	Mechanical spring	920	230	EK4/MV
	3/2 N.C. monostable					
	3/2 bistable	Front lever	Front lever	920	230	EK4/MVF
	5/2 monostable	Front lever	Mechanical spring	920	185	EKCA4/MV
	5/2 bistable	Front lever	Front lever	920	185	EKCA4/MVF
	3/2 N.O. monostable	Lateral knob	Mechanical spring	920	255	EK4/M
	3/2 N.C. monostable					
	3/2 bistable	Lateral knob	Lateral knob	920	250	EK4/MF
	5/2 monostable	Lateral knob	Mechanical spring	920	310	EKCA4/M
	5/2 bistable	Lateral knob	Lateral knob	920	310	EKCA4/MF
	5/3 monostable closed centre	Lateral knob	Mechanical spring	780	310	EKCA4/MS
	5/3 stable closed centre	Lateral knob	Lateral knob	780	310	EKCA4/MSF
	5/3 monostable open centre	Lateral knob	Mechanical spring	780	310	EKCA4/MA
	5/3 stable open centre	Lateral knob	Lateral knob	780	310	EKCA4/MAF

*EX Consistent with the ATEX directive II 2GD c T5 T100°C -20°C ≤ Ta ≤ 60°C

E.G.: EK4/TF/EX

3

EK4/T - EK4/TF

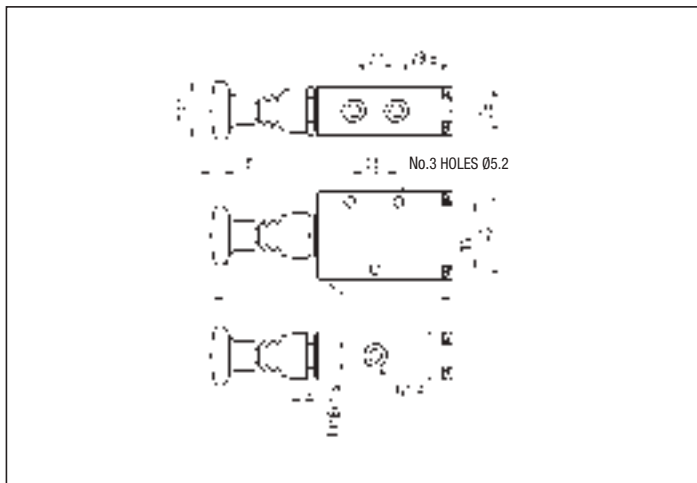

EKCA4/T - EKCA4/TF

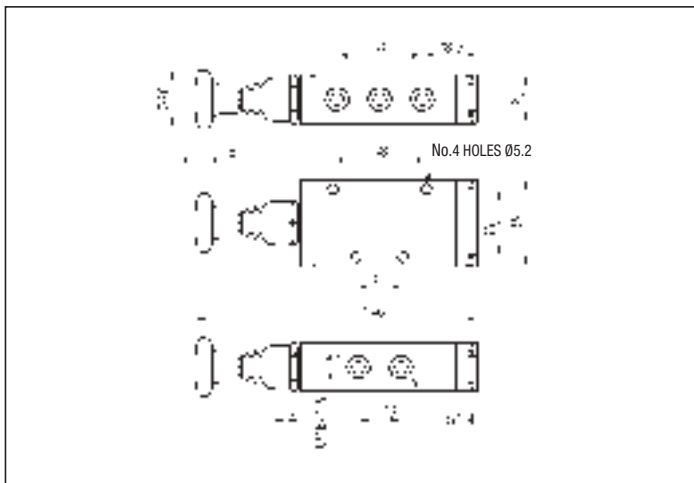

EK4/MV - EK4/MVF

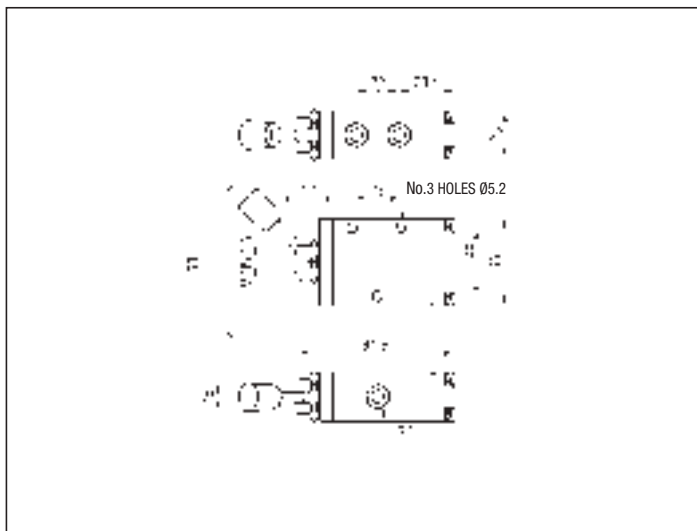

EKCA4/MV - EKCA4/MVF

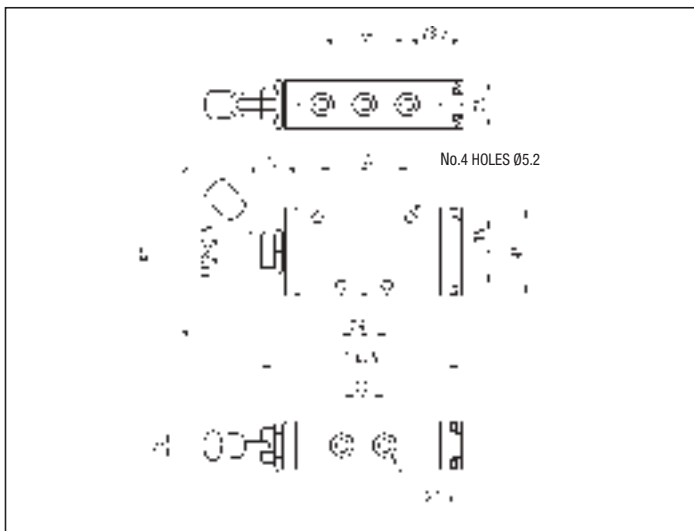

EK4/M - EK4/MF

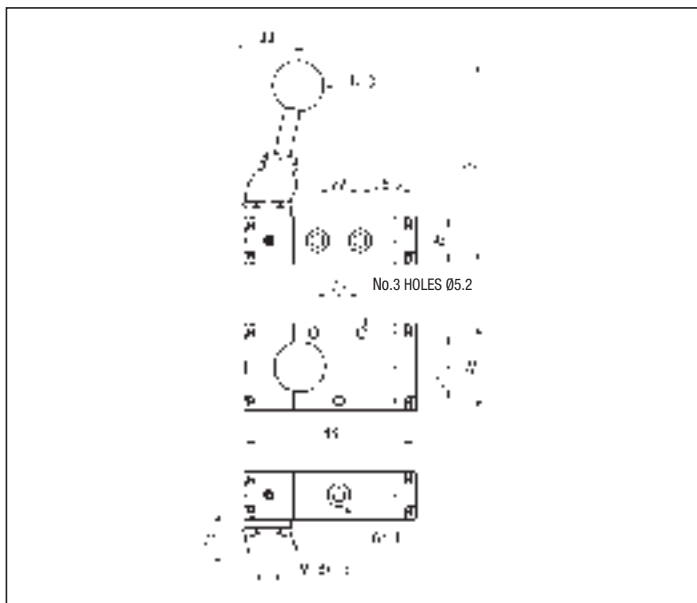

5/2 - 5/3 LATERAL KNOB

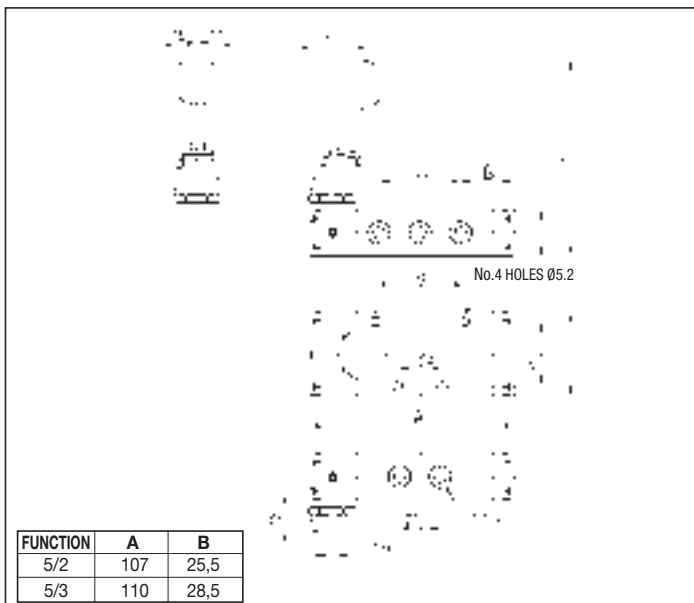

MANUALLY ACTUATED VALVES G 1/2

Symbol	Function	Controls		Flow rate at 6 bar $\Delta P = 1 \text{ bar (Nl/min)}$	Weight (g)	TYPE*
		Pilot	Return			
	5/2 monostable	Lateral knob	Mechanical spring	2250	1200	EKCA2/M
	5/2 bistable	Lateral knob	Lateral knob	2250	1200	EKCA2/MF
	5/3 monostable closed centre	Lateral knob	Mechanical spring	2000	1200	EKCA2/MS
	5/3 stable closed centre	Lateral knob	Mechanical spring	2000	1200	EKCA2/MSF
	5/3 monostable open centre	Lateral knob	Mechanical spring	2000	1200	EKCA2/MA
	5/3 stable open centre	Lateral knob	Lateral knob	2000	1200	EKCA2/MAF

*EX Consistent with the ATEX directive II 2GD c T5 T100°C -20°C ≤ Ta ≤ 60°C E.G.: EKCA2/MF/EX

5/2 - 5/3 LATERAL KNOB

FUNCTION	A	B
5/2	194,5	48
5/3	198	51,5

Poppet valves manually and mechanically actuated G 1/8 - G 1/4 - G 1/2

series CA

DESCRIPTION

Valves series "CA" are produced in the 2/2, 3/2, 3/3, 5/2 and 5/3 pneumatic functions. The poppet kind of construction and the very rugged control allow the valve to stand high stress. The push-button and mushroom controls are available only in the 3/2 monostable pneumatic functions for the size G 1/8. They are in compliance with ATEX directive, 2GD category, upon request.



TECHNICAL DATA

Operating pressure	0 ÷ 12 bar
Working temperature	0 ÷ +70 °C (-20° C with dry air)
Fluid	Compressed air, filtered, continuous lubricated, unlubricated or dry lubricated
Port size	G 1/8 - G 1/4 - G 1/2
Nominal diameter	G 1/8 = 6 mm G 1/4 = 8 mm G 1/2 = 12 mm
Controls	
Mechanical:	Plunger; roller lever; short roller lever; unidirectional roller lever
Manual:	Tapper; push-button; mushroom; vertical knob; lateral knob; lateral hand-wheel

MATERIALS

Control rod	Hardened and nickel - plated steel
Body	Anodized aluminium alloy
Springs	Stainless steel
Seals	NBR rubber
Piston	Acetal resin
Guide bushing	Brass
Bottom plug	Nickel - plated brass
Controls	
Lever	Steel
Plunger	Nickel - plated brass
Knobs; handgrips; push-buttons	Plastic material
Roller	Ball bearing (plastic material upon request)

SPARE PARTS

SEALS KIT	
3/2 N.O. G 1/8	A/SG/8
3/2 N.C. G 1/8	C/SG/8
5/2 G 1/8	CA/SG/8
3/2 N.O. G 1/4	A/SG/4
3/2 N.C. G 1/4	C/SG/4
5/2 G 1/4	CA/SG/4
3/2 N.O. G 1/2	A/SG/2
3/2 N.C. G 1/2	C/SG/2
5/2 G 1/2	CA/SG/2

FLOW CHART - CA G 1/8 - 5/2

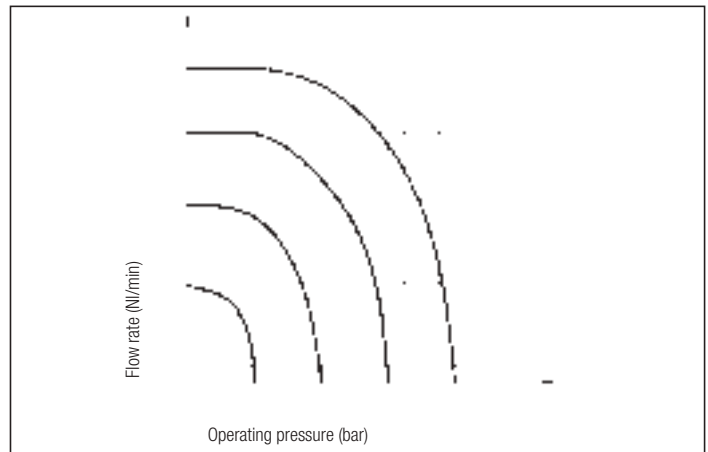

FLOW CHART - CA G 1/2 - 5/2

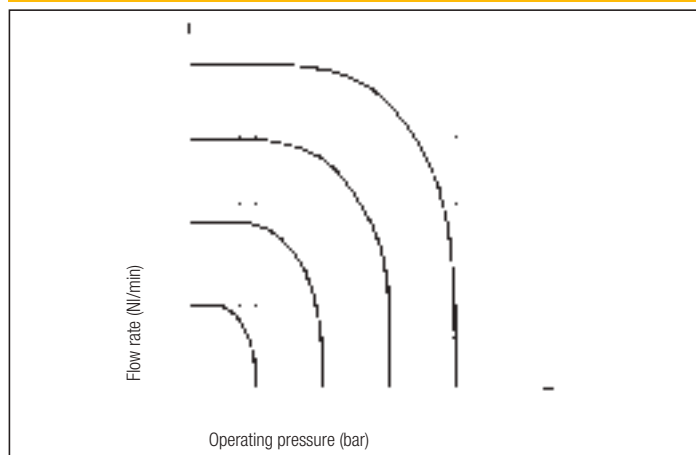

FLOW CHART - CA G 1/4 - 5/2

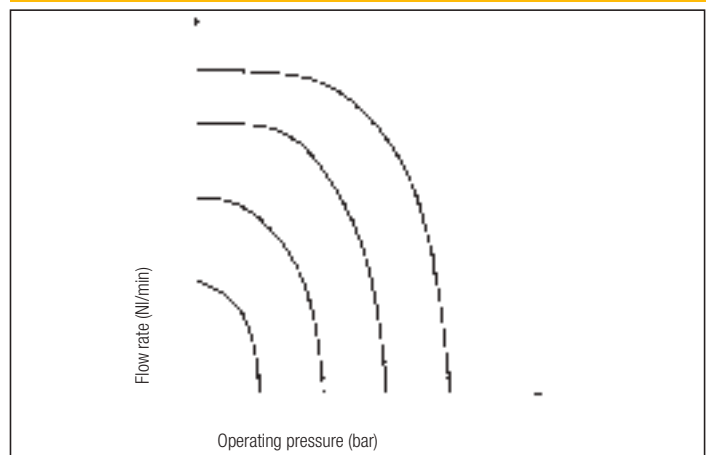

3

MECHANICALLY ACTUATED VALVES G 1/8 - G 1/4 - G 1/2

Symbol	Function	Controls		Actuation force at 6 bar (N)	Flow rate at 6 bar $\Delta P = 1 \text{ bar}$ (Nl/min)	Weight (g)	Port size	TYPE*
		Pilot	Return					
	3/2 N.O. monostable	Plunger	Mechanical spring	38	740	70	G 1/8	AS 8
				60	950	150	G 1/4	AS4
				88	2200	300	G 1/2	AS2
	3/2 N.C. monostable	Plunger	Mechanical spring	36	815	70	G 1/8	CS8
				64	950	150	G 1/4	CS4
				85	2250	300	G 1/2	CS2
	3/2 N.O. monostable	Roller lever	Mechanical spring	23	740	95	G 1/8	ALR8
				35	950	215	G 1/4	ALR4
				53	2200	415	G 1/2	ALR2
	3/2 N.C. monostable	Roller lever	Mechanical spring	24	815	95	G 1/8	CLR8
				34	950	215	G 1/4	CLR4
				52	2250	415	G 1/2	CLR2
	3/2 N.O. monostable	Unidirectional roller lever	Mechanical spring	30	740	100	G 1/8	ALRU8
				53	950	200	G 1/4	ALRU4
				64	2200	405	G 1/2	ALRU2
	3/2 N.C. monostable	Unidirectional roller lever	Mechanical spring	26	815	100	G 1/8	CLRU8
				50	950	200	G 1/4	CLRU4
				63	2250	405	G 1/2	CLRU2
	3/2 N.O. monostable	Short roller lever	Mechanical spring	35	740	110	G 1/8	AR8
	3/2 N.C. monostable	Short roller lever	Mechanical spring	33	815	110	G 1/8	CR8
	3/2 N.C. monostable	Plunger	Mechanical spring	48	815	70	G 1/8	FCS8**
				162	950	150	G 1/4	FCS4**
	3/2 N.C. monostable	Roller lever	Mechanical spring	25	815	95	G 1/8	FCLR8**
				70	950	215	G 1/4	FCLR4**
	3/2 N.C. monostable	Unidirectional roller lever	Mechanical spring	27	815	95	G 1/8	FCLRU8**
				80	950	215	G 1/4	FCLRU4**
	3/2 N.C. monostable	Short roller lever	Mechanical spring	69	815	110	G 1/8	FCR8**
	5/2 monostable	Plunger	Mechanical spring	62	650	140	G 1/8	CASS8
				103	1040	305	G 1/4	CASS4
				120	2050	600	G 1/2	CASS2
	5/2 monostable	Roller lever	Mechanical spring	38	650	190	G 1/8	CALR8
				64	1040	405	G 1/4	CALR4
				45	2050	765	G 1/2	CALR2
	5/2 monostable	Unidirectional roller lever	Mechanical spring	43	650	190	G 1/8	CALRU8
				68	1040	405	G 1/4	CALRU4
				94	2050	775	G 1/2	CALRU2

P.S.: ADD THE LETTER "N" AFTER THE LETTER "R" IN THE TYPE TO ORDER THE VALVES WITH PLASTIC ROLLER (AVAILABLE ONLY FOR THE SIZES G 1/8 AND G 1/4). E.G.: **CLRN8**

PUT THE LETTER "H" BEFORE THE TYPE OF 3/2 VALVES TO ORDER THE 2/2 N.O. AND 2/2 N.C. VALVES. E.G.: **HCS8; HAR8**

*EX Consistent with the ATEX directive II 2GD c T5 T100°C -20°C ≤ T_a ≤ 60°C E.G.: **CS4/EX**

** THE WAYS AREN'T COMMUNICATING IN THE INTERMEDIATE PHASE OF ACTUATION

3/2 SHORT ROLLER LEVER

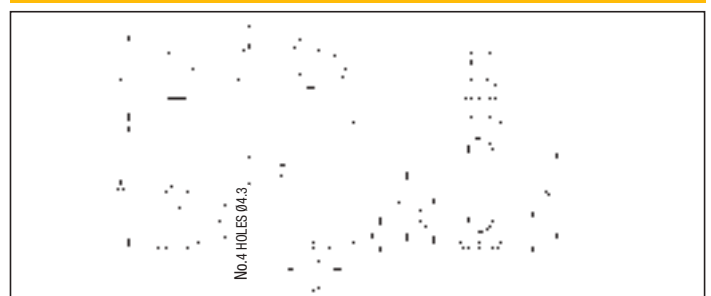

3/2 PLUNGER

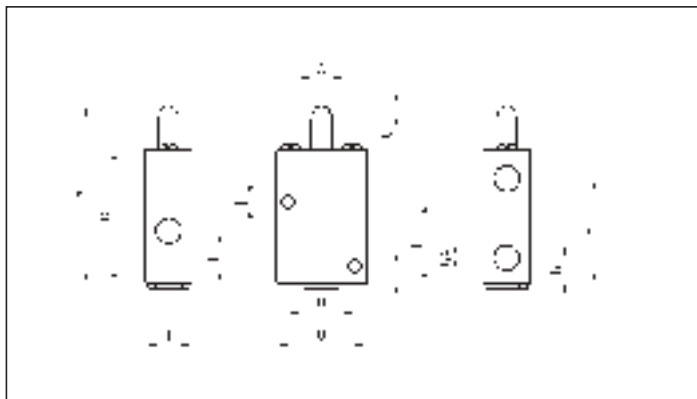

3/2 ROLLER LEVER

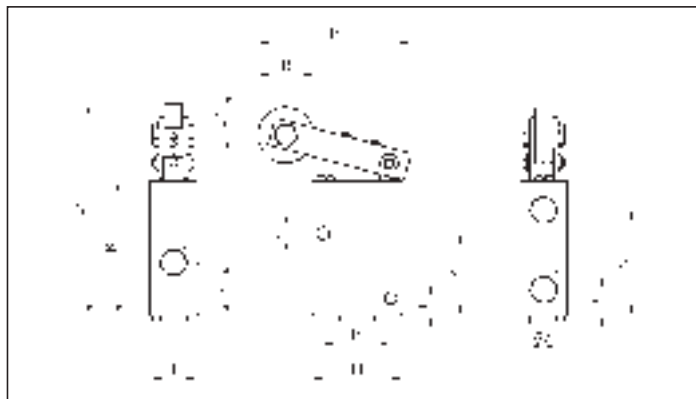

3/2 UNIDIRECTIONAL ROLLER LEVER

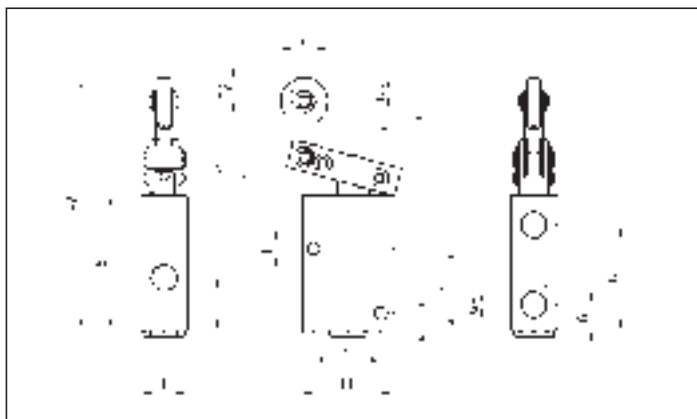

5/2 PLUNGER

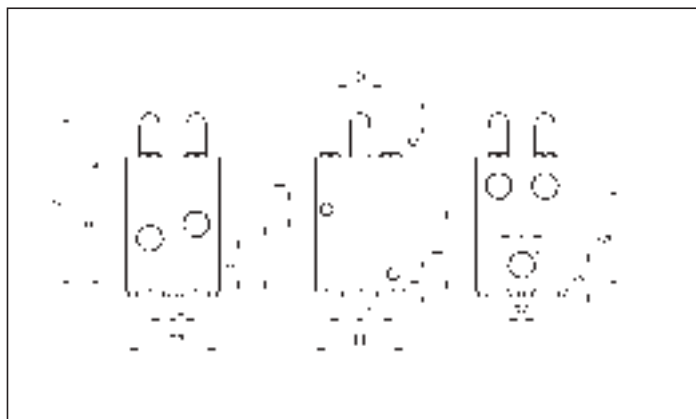

5/2 ROLLER LEVER

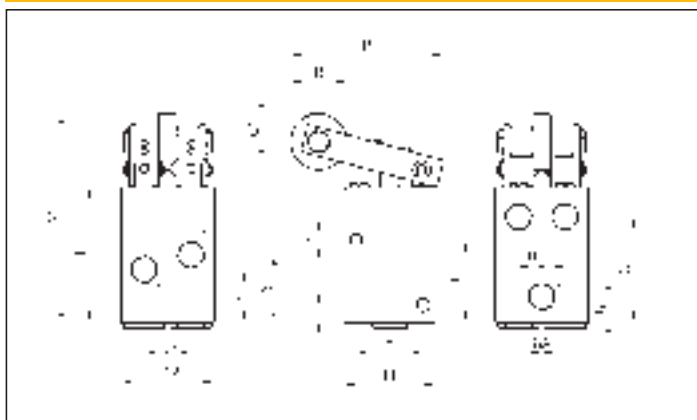

5/2 UNIDIRECTIONAL ROLLER LEVER



GA	A	A1	A2	B	C		C1		C2		C3	D	E	F
					min	max	min	max	min	max				
G 1/8	59	74	88	46	1,5	3	5,5	10	5	8	10	27	4,3	28
G 1/4	75	95	111	60	2	4	7,5	13,5	5	8	12	35	5,3	35
G 1/2	100	123	142	80	3	5,5	10,5	15,5	7	10	14	42,5	6,4	49

GA	G	H	I	L		M	N	N1	O	P	Q	S	T	T2
				N.O.	N.C.									
G 1/8	8,8	23	6	23	18	31	19	16	6,9	53	36	23	16	32
G 1/4	11,5	30	8	30	25,5	40	26	19	9	69	46	30	20	40
G 1/2	15	38	10	40	30	50	32	24	12	80,5	63,3	40	25	50

GA	U	V
G 1/8	16	46
G 1/4	20	54
G 1/2	25	70

2 AND 3 PORT MANUALLY ACTUATED G 1/8 - G 1/4 - G 1/2

Symbol	Function	Controls		Flow rate at 6 bar $\Delta P = 1$ bar (Nl/min)	Weight (g)	Port size	TYPE*
		Pilot	Return				
	3/2 N.O. monostable	Tapper	Mechanical spring	740	90	G 1/8	AT8
				950	195	G 1/4	AT4
				2200	415	G 1/2	AT2
	3/2 N.C. monostable	Tapper	Mechanical spring	815	90	G 1/8	CT8
				950	205	G 1/4	CT4
				2250	425	G 1/2	CT2
	3/2 N.O. monostable	Push-button	Mechanical spring	740	125	G 1/8	AQB8**
	3/2 N.C. monostable	Push-button	Mechanical spring	815	125	G 1/8	CQB8**
	3/2 N.O. monostable	Mushroom	Mechanical spring	740	125	G 1/8	AQF8**
	3/2 N.C. monostable	Mushroom	Mechanical spring	815	125	G 1/8	CQF8**
	3/2 N.O. monostable	Vertical knob	Mechanical spring	740	185	G 1/8	AM8
				950	355	G 1/4	AM4
				2200	655	G 1/2	AM2
	3/2 N.C. monostable	Vertical knob	Mechanical spring	815	185	G 1/8	CM8
				950	355	G 1/4	CM4
				2250	655	G 1/2	CM2
	3/2 N.O. bistable	Vertical knob	Vertical knob	740	180	G 1/8	AM8F
				950	345	G 1/4	AM4F
				2200	645	G 1/2	AM2F
	3/2 N.C. bistable	Vertical knob	Vertical knob	815	180	G 1/8	CM8F
				950	345	G 1/4	CM4F
				2250	645	G 1/2	CM2F
	3/2 N.O. monostable	Lateral knob	Mechanical spring	740	240	G 1/8	AML8
				950	400	G 1/4	AML4
	3/2 N.C. monostable	Lateral knob	Mechanical spring	815	240	G 1/8	CML8
				950	400	G 1/4	CML4
	3/2 N.O. bistable	Lateral knob	Lateral knob	740	245	G 1/8	AML8F
				950	390	G 1/4	AML4F
	3/2 N.C. bistable	Lateral knob	Lateral knob	815	245	G 1/8	CML8F
				950	390	G 1/4	CML4F
	3/2 N.O. monostable	Lateral hand-wheel	Mechanical spring	740	270	G 1/8	AVL8
				950	415	G 1/4	AVL4
	3/2 N.C. monostable	Lateral hand-wheel	Mechanical spring	815	270	G 1/8	CVL8
				950	415	G 1/4	CVL4
	3/2 N.O. bistable	Lateral hand-wheel	Lateral hand-wheel	740	265	G 1/8	AVL8F
				950	405	G 1/4	AVL4F
	3/2 N.C. bistable	Lateral hand-wheel	Lateral hand-wheel	815	265	G 1/8	CVL8F
				950	405	G 1/4	CVL4F

*EX Consistent with the ATEX directive II 2GD c T5 T100°C -20°C ≤ T_{amb} ≤ 60°C E.G.: **AVL8/EX**

** PUSH-BUTTON COLOUR: N = BLACK; R = RED; V = GREEN - P.S.: THE VERSION WITH BLACK VERTICAL KNOB IS AVAILABLE ONLY IN THE SIZES G 1/8 AND G 1/4; TO ORDER THIS VERSION ADD THE SUFFIX "E" TO THE TYPE. E.G.: **CM8/E; AM8/E**

PUT THE LETTER "H" BEFORE THE TYPE OF 3/2 VALVES TO ORDER THE 2/2 N.O. AND 2/2 N.C. VALVES. E.G.: **HCM4; HAT2**

3/2 MUSHROOM

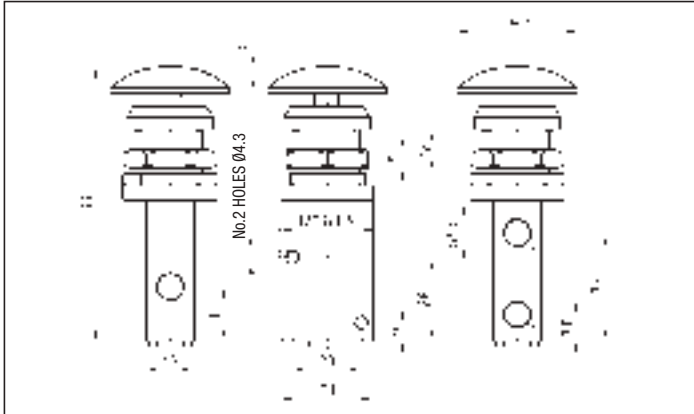

3/2 PUSH-BUTTON

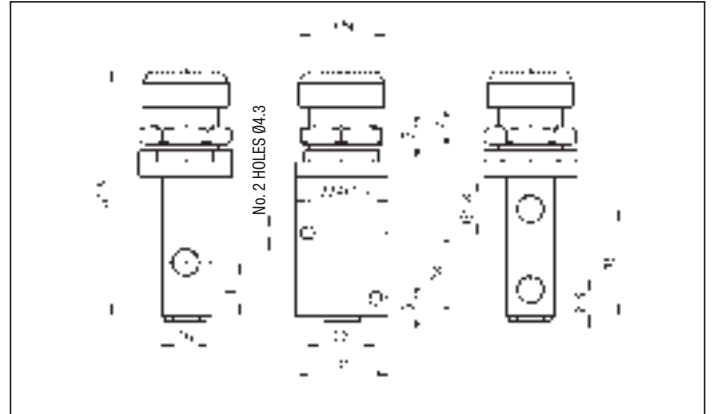

3/2 TAPPER

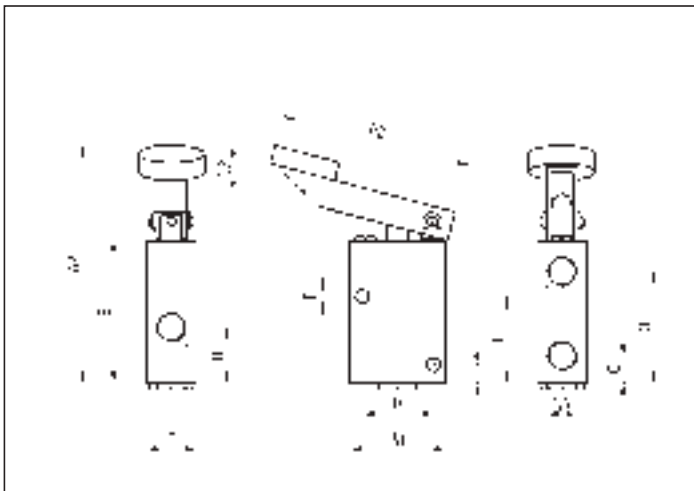

3/2 VERTICAL KNOB

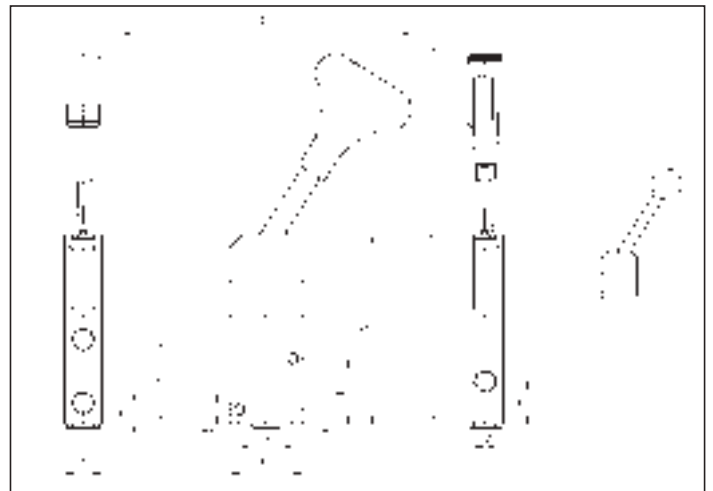

3/2 LATERAL KNOB

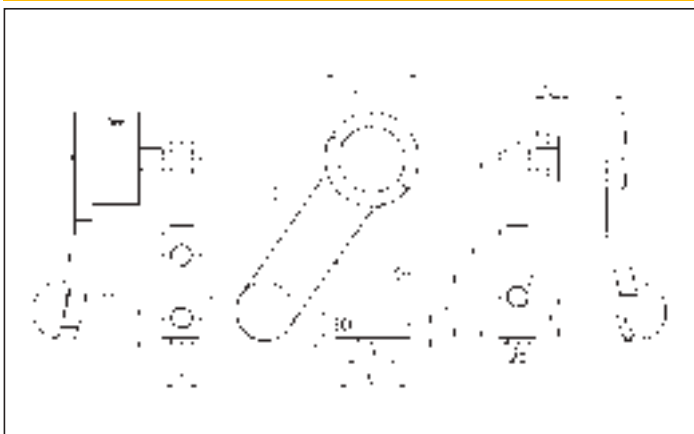

3/2 LATERAL HAND-WHEEL

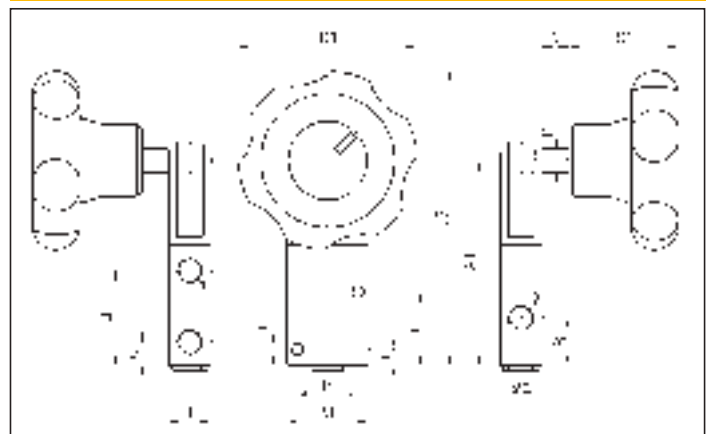

GA	A	A1	A2	B	C	C1	C2		D	D1	E	F	G	H
							min	max						
G 1/8	80	77	78	46	20	42	8	15,5	36	70	4,3	28	8,8	23
G 1/4	100	95	98	60	20	42	11	22,5	36	70	5,3	35	11,5	30
G 1/2	130	124	100	80	-	-	28	35	-	-	6,4	49	15	38

GA	I	L	L1	L2	M	N	O	P	P2	Q	R		T
											N.O.	N.C.	
G 1/8	6	162	100	112	31	10	9	124	60	36	23	18	16
G 1/4	8	188	100	130	40	10	9	152	83	46	30	25,5	20
G 1/2	10	238	-	-	50	-	-	180	145	63,3	40	30	25

3

3 PORT, 3 POSITIONS AND 5 PORT MANUALLY ACTUATED VALVES - G 1/8 - G 1/4 - G 1/2

Symbol	Function	Controls		Flow rate at 6 bar $\Delta P = 1$ bar (Nl/min)	Weight (g)	Port size	TYPE*
		Pilot	Return				
	5/2 monostable	Tapper	Mechanical spring	650	180	G 1/8	CAT8
				1040	405	G 1/4	CAT4
				2050	790	G 1/2	CAT2
	5/2 monostable	Vertical knob	Mechanical spring	650	315	G 1/8	CAM8
				1040	600	G 1/4	CAM4
				2050	1160	G 1/2	CAM2
	5/2 bistable	Vertical knob	Vertical knob	650	290	G 1/8	CAM8F
				1040	570	G 1/4	CAM4F
				2050	1065	G 1/2	CAM2F
	5/2 monostable	Lateral knob	Mechanical spring	650	375	G 1/8	CAML8
				1040	650	G 1/4	CAML4
	5/2 bistable	Lateral knob	Lateral knob	650	365	G 1/8	CAML8F
				1040	635	G 1/4	CAML4F
	5/2 monostable	Hand-wheel	Mechanical spring	650	395	G 1/8	CAVL8
				1040	665	G 1/4	CAVL4
	5/2 bistable	Lateral hand-wheel	Lateral hand-wheel	650	380	G 1/8	CAVL8F
				1040	650	G 1/4	CAVL4F
	5/3 monostable open centre	Vertical knob	Mechanical spring	815	315	G 1/8	CCM8
				950	605	G 1/4	CCM4
				2250	1165	G 1/2	CCM2
	5/3 stable open centre	Vertical knob	Vertical knob	815	290	G 1/8	CCM8F
				950	575	G 1/4	CCM4F
				2250	1095	G 1/2	CCM2F
	5/3 monostable open centre	Lateral knob	Mechanical spring	815	385	G 1/8	CCML8
				950	675	G 1/4	CCML4
	5/3 stable open centre	Lateral knob	Lateral knob	815	370	G 1/8	CCML8F
				950	650	G 1/4	CCML4F
	5/3 monostable open centre	Lateral hand-wheel	Mechanical spring	815	405	G 1/8	CCVL8
				950	690	G 1/4	CCVL4
	5/3 stable open centre	Lateral hand-wheel	Lateral hand-wheel	815	385	G 1/8	CCVL8F
				950	660	G 1/4	CCVL4F
	3/3 monostable closed centre	Vertical knob	Mechanical spring	815	310	G 1/8	HCCM8
				950	600	G 1/4	HCCM4
	3/3 stable closed centre	Vertical knob	Mechanical spring	815	310	G 1/8	HCCM8F
				950	600	G 1/4	HCCM4F
	3/3 monostable closed centre	Vertical knob	Mechanical spring	815	310	G 1/8	HCCML8
				950	600	G 1/4	HCCML4
	3/3 stable closed centre	Vertical knob	Mechanical spring	815	310	G 1/8	HCCML8F
				950	600	G 1/4	HCCML4F
	5/3 monostable closed centre	Vertical knob	Mechanical spring	815	740	G 1/8	XH4CM8
				950	1605	G 1/4	XH4CM4
				2250	3185	G 1/2	XH4CM2
	5/3 stable closed centre	Vertical knob	Vertical knob	815	680	G 1/8	XH4CM8F
				1400	1555	G 1/4	XH4CM4F
				2250	3080	G 1/2	XH4CM2F

5/2 TAPPER

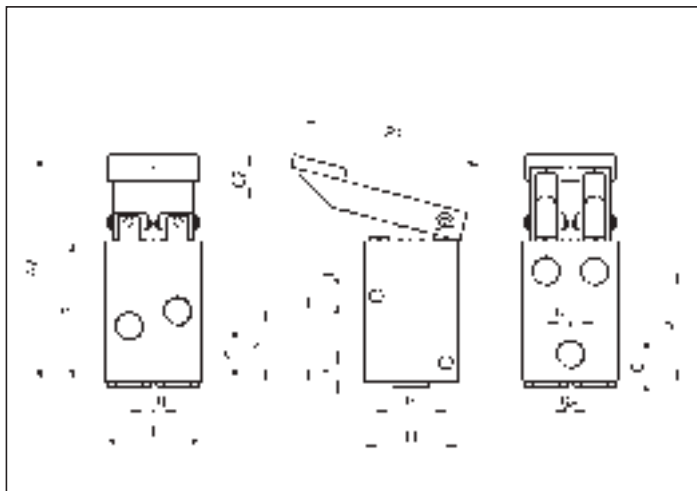

5/2 - 5/3 O.C. - 3/3 C.C. VERTICAL KNOB

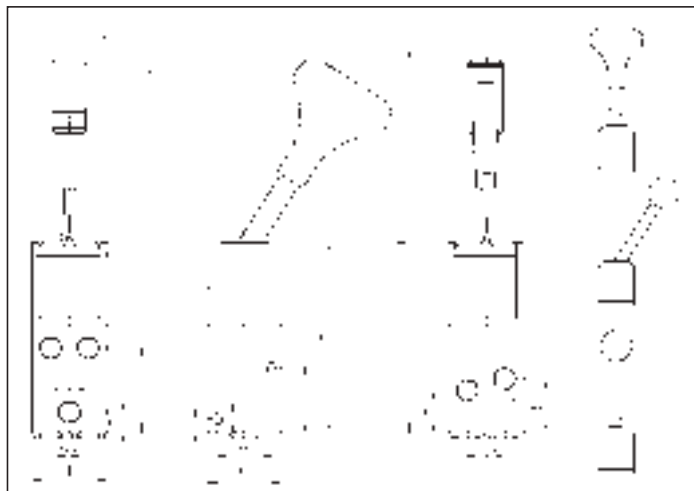

5/2 - 5/3 O.C. - 3/3 C.C. LATERAL KNOB

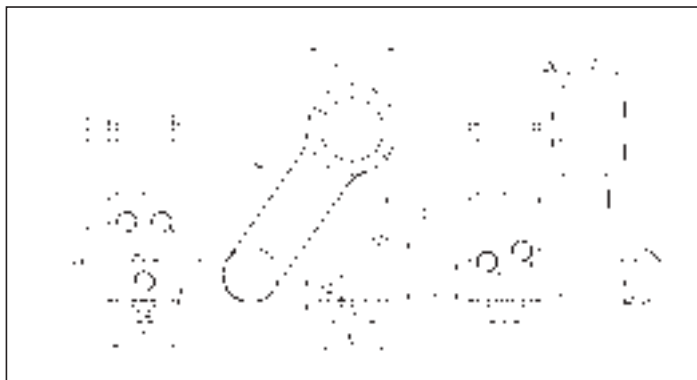

5/2 LATERAL HAND-WHEEL

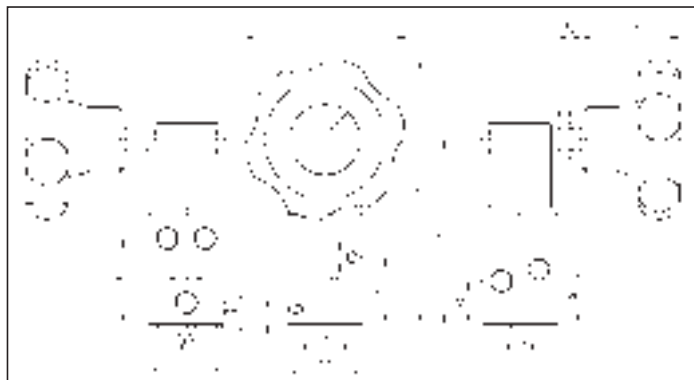

A	A	A1	A2	B	C	C1	C2		D	D1	E	F	G	H
							min	max						
G 1/8	80	77	75,5	46	20	42	8	15,5	36	70	4,3	28	8,8	23
G 1/4	100	95	95	60	20	42	11	22,5	36	70	5,3	35	11,5	30
G 1/2	130	124	83	80	-	-	28	35	-	-	6,4	49	15	38

GA	I	L	L1	L2	M	N	O	P	P2	Q	R		S	T
											N.O.	N.C.		
G 1/8	6	162	100	112	31	10	9	124	60	36	23	18	23	32
G 1/4	8	188	100	130	40	10	9	152	83	46	30	25,5	30	40
G 1/2	10	238	-	-	50	-	-	180	145	63,3	40	30	40	50

GA	U
G 1/8	16
G 1/4	20
G 1/2	25

P.S.: THE VERSION WITH BLACK VERTICAL KNOB IS AVAILABLE ONLY IN THE SIZES G 1/8 AND G 1/4; TO ORDER THIS VERSION ADD THE SUFFIX "E" TO THE TYPE. E.G.: **CAM8/E**; **CCM8/E**

*EX Consistent with the ATEX directive  II 2GD c T5 T100°C -20°C≤Tas60°C E.G.: **CS4/EX**

3

5/3 C.C. VERTICAL KNOB G 1/8

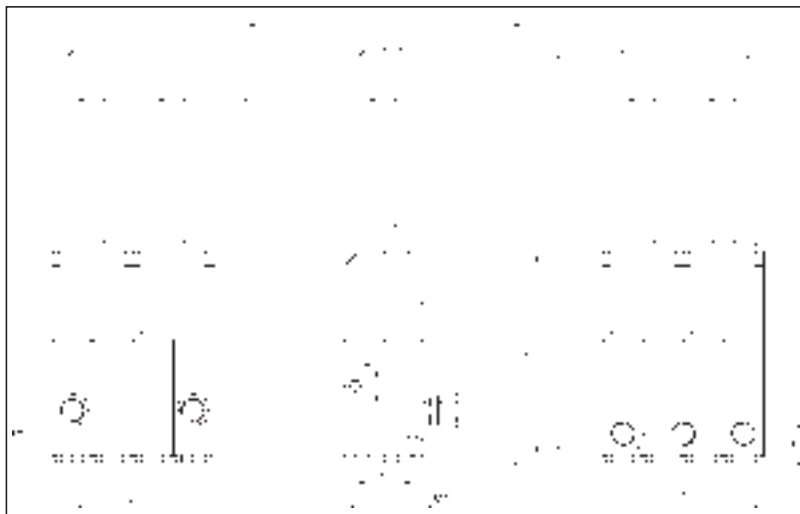

5/3 C.C. VERTICAL KNOB G 1/4 - G 1/2

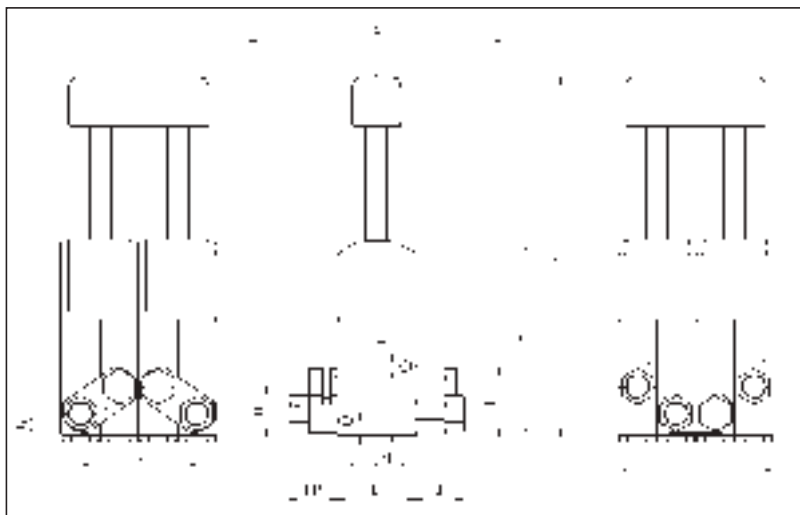

GA	A	E	F	G	H	I	L	M	M1	P		Q	T	U
										with catch	without catch			
G 1/8	81	4,3	28	8,8	23	6	157,5	31	15	111	70	18	64	48
G 1/4	100	5,3	35	11,5	30	8	185	40	24	132	84	25,5	80	60
G 1/2	130	6,4	49	15	38	10	235	50	29	162	60	30	100	75

DESCRIPTION

Pedal actuated valves series "PC" are produced in the 3/2 and 5/2 pneumatic functions, with or without protection, and they are based on direct acting poppet valves and direct acting or pilot assisted spool valves in the sizes G 1/8 and G 1/4.

The catch on the pedal allows obtaining the bistable pneumatic functions, while the safety device avoids the accidental actuation of the same pedal.

They are in compliance with ATEX directive, 2GD category, upon request.



3

TECHNICAL DATA

Operating pressure	0 ÷ 10 bar (with direct acting valves) 2,5 ÷ 10 bar (with pilot assisted valves)
Working temperature	0 ÷ +50 °C (-10°C with dry air)
Fluid	Compressed air, filtered, continuous lubricated, unlubricated or dry lubricated
Port size	G 1/8 - G 1/4
Nominal diameter	G 1/8 = 6 mm G 1/4 = 8,5 mm

MATERIALS

Control rod	Hardened and nickel - plated steel – nickel - plated brass
Body	Anodized aluminium alloy
Spool	Aluminium alloy
Springs	Stainless steel
Seals	NBR rubber
Protection cover	Die - cast aluminium - Plastic material
Safety device	Plastic material
Catch	Plastic material
Control lever	Press-forged aluminium - Plastic material

FLOW CHART - PC G 1/8 - 5/2

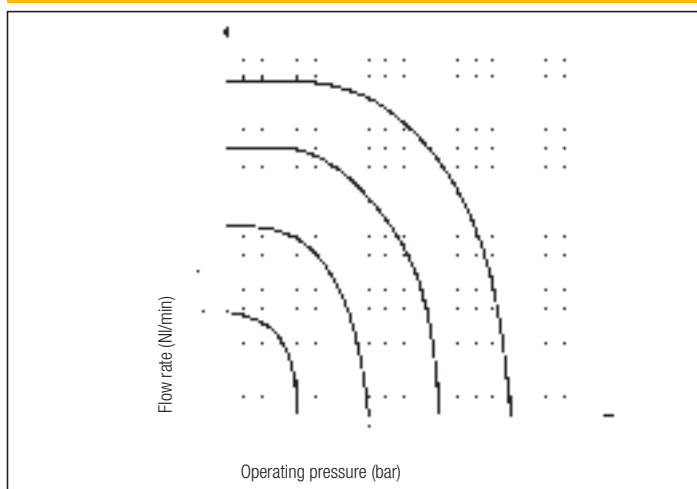

FLOW CHART - PC G 1/4 - 5/2

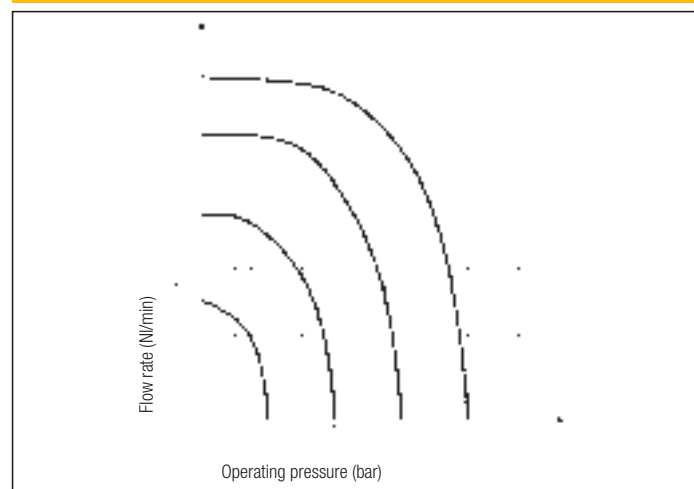

PEDAL ACTUATED VALVES G 1/8 - G 1/4

Symbol	Function	Protection	Actuation	Flow rate at 6 bar $\Delta P = 1$ bar (Nl/min)	Weight (g)	Port size	TYPE*
	3/2 N.O. monostable	-	Direct acting	740	565	G 1/8	AP8
				950	700	G 1/4	AP4
	3/2 N.C. monostable	-	Direct acting	815	570	G 1/8	CP8
				950	700	G 1/4	CP4
	3/2 N.C. monostable	-	Direct acting	815	570	G 1/8	FCP8*
	3/2 N.O. monostable	-	Direct acting	900	970	G 1/4	PNP4
	3/2 N.C. monostable						
	3/2 N.O. bistable	-	Direct acting	900	970	G 1/4	PNP4/F
	3/2 N.C. bistable						
	5/2 monostable	-	Direct acting	900	1020	G 1/4	PNPCA4
	5/2 bistable	-	Direct acting	900	1020	G 1/4	PNPCA4/F
	5/3 monostable closed centre	-	Direct acting	780	1020	G 1/4	PNPCA4/S
	5/3 stable closed centre	-	Direct acting	780	1020	G 1/4	PNPCA4/SF
	5/3 monostable open centre	-	Direct acting	780	1020	G 1/4	PNPCA4/A
	5/3 stable open centre	-	Direct acting	780	1020	G 1/4	PNPCA4/AF
	5/2 with safety device monostable	Plastic	Pilot assisted	900	1350	G 1/4	PCA4

* THE WAYS AREN'T COMMUNICATING IN THE INTERMEDIATE PHASE OF ACTUATION

PEDAL ACTUATED VALVES G 1/8 - G 1/4

Symbol	Function	Protection	Actuation	Flow rate at 6 bar $\Delta P = 1$ bar (Nl/min)	Weight (g)	Port size	TYPE
	5/2 with safety device bistable	Plastic	Pilot assisted	900	1350	G 1/4	PCA4/F
	5/2 with safety device monostable	Metallic	Pilot assisted	900	1750	G 1/4	PCA4M
	5/2 with safety device bistable	Metallic	Pilot assisted	900	1750	G 1/4	PCA4M/F

3

AP8 - AP4 - CP8 - CP4 - FCP8

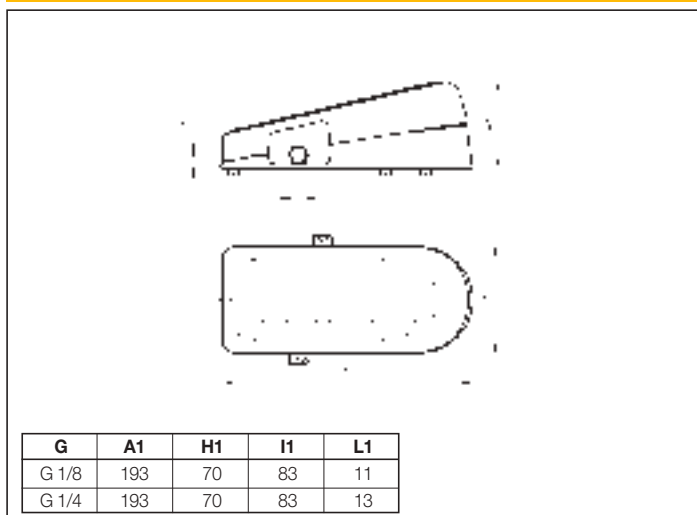

3/2 - 5/2 - 5/3 BALANCING WITHOUT PROTECTION - PNP

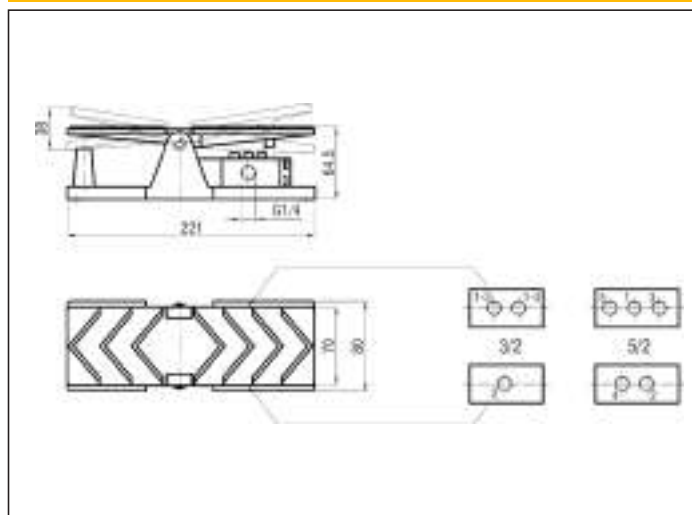

5 PORT PLASTIC AND METALLIC PROTECTION - PCA

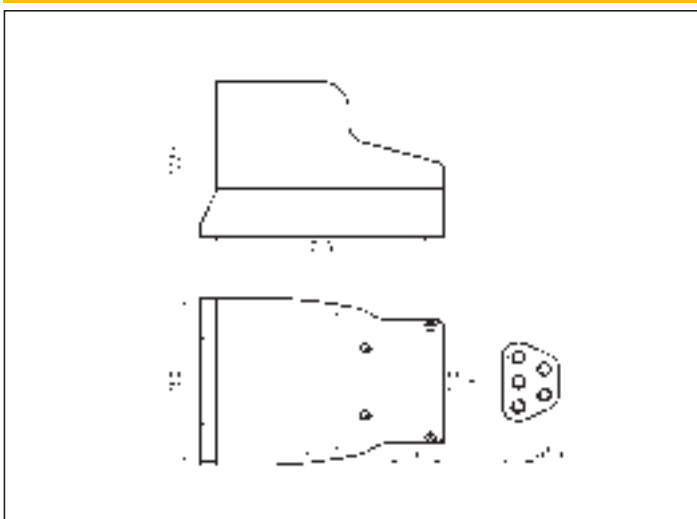

Complementary valves: shuttle, quick exhaust and check valves

DESCRIPTION

Complementary valves are very important components of the pneumatic circuits. This group includes the:

- **SHUTTLE VALVES:** these valves are used when there is the necessity to convey, in one pipeline, two pneumatic flows coming from two different pipelines without any interference; in fact the compressed air flows from one of the two inlet ports to the working port while the second inlet port is excluded.

- **QUICK EXHAUST VALVES:** air flows from the inlet port to the working port while the exhaust port is closed. By shutting off the inlet port, the compressed air from the working port is exhausted through the exhaust port.

- **CHECK VALVES:** these valves are used to prevent loss of pressure in a pipeline when the inlet is connected to the exhaust; the compressed air can flow freely from the inlet to the working port while the opposite direction is blocked.

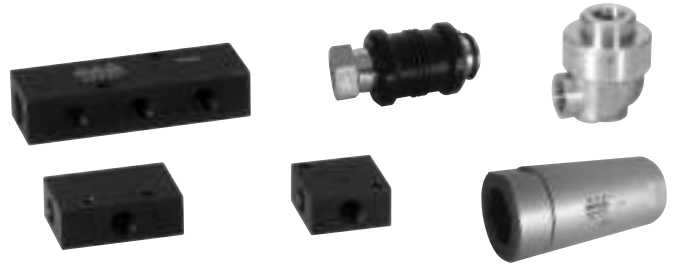

3

SHUTTLE VALVES SERIES DS

TECHNICAL DATA

Operating pressure	0 ÷ 12 bar
Working temperature	0 ÷ +80° C (-20° C with dry air)
Fluid	Compressed air, filtered, continuous lubricated, unlubricated or dry lubricated
Port size	G 1/8 - G 1/4 - G 3/8 - G 1/2

MATERIALS

Body	Aluminium alloy
Seals	NBR rubber

DIMENSIONS AND WEIGHTS DS

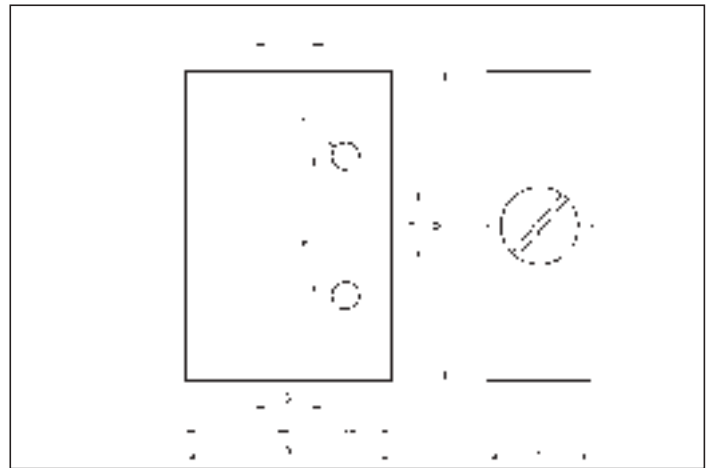

Symbol	B	I	L	M	N	O	P	Flow rate at 6 bar ΔP=1 bar (NI/min)	Pmin (bar)	Weight (g)	G	TYPE
	4,2	6	16	46	31	13	22	700	0,2	60	G 1/8	DS8
	5,2	8	20	60	40	17,5	27	1700	0,4	125	G 1/4	DS4
	6,4	10	25	80	50	21	38	3400	0,3	235	G 3/8	DS3
	6,4	12	30	100	60	26	48	5000	0,6	435	G 1/2	DS2

QUICK EXHAUST VALVES SERIES D3/

TECHNICAL DATA

Operating pressure	0 ÷ 12 bar
Working temperature	0 ÷ +80° C (-20° C with dry air)
Fluid	Compressed air, filtered, continuous lubricated, unlubricated or dry lubricated
Port size	G 1/4 - G 1/2 - G 3/4

MATERIALS

Body	Aluminium alloy
Seals	NBR rubber
Bottom	Aluminium alloy

DIMENSIONS AND WEIGHTS D3/

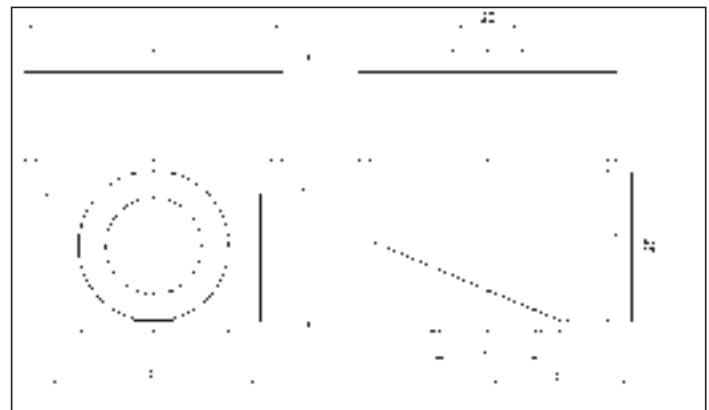

Symbol	A	B	E	R	Flow rate from 1 to 2 at 6 bar ΔP=1 bar (NI/min)	Flow rate from 2 to 3 at 6 bar free exhaust (NI/min)	Pmin (bar)	Weight (g)	GA	GB	GC	TYPE
	38	35	19,5	27	520	2300	0,2	70	G 1/4	G 1/4	G 1/8	D3/4
	43	35	19,5	27	610	2300	0,2	75	G 1/4	G 1/4	G 1/4	D3/4B
	54	50	27,5	41	1520	4300	0,2	135	G 1/2	G 1/2	G 1/4	D3/2
	58	50	27,5	41	2220	4300	0,2	140	G 1/2	G 1/2	G 1/2	D3/2B
	82	82	44	70	4400	6000	0,2	510	G 3/4	G 3/4	G 1/2	D3/15

Complementary valves: check and slide valves, distribution frames

3

CHECK VALVES SERIES U

TECHNICAL DATA

Operating pressure	0 ÷ 12 bar
Working temperature	0 ÷ +80° C (-20° C with dry air)
Fluid	Compressed air, filtered, continuous lubricated, unlubricated or dry lubricated
Port size	G 1/8 - G 1/4 - G 1/2 - G 1

MATERIALS

Body	Anodized aluminium
Piston	Brass
Seals	NBR rubber
Spring	Stainless steel

DIMENSIONS AND WEIGHTS U

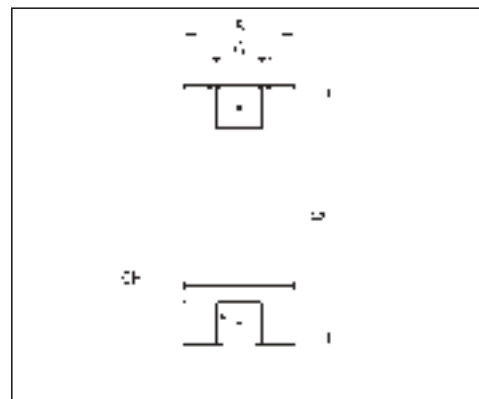

Symbol	CH	A	Q	Flow rate at 6 bar ΔP=1 bar (NI/min)	Pmin (bar)	Weight (g)	G	TYPE
	13	15	34	70	0,2	25	G 1/8	U8
	19	21	48	700	0,7	75	G 1/4	U4
	19	21	48	725	0,2	75	G 1/4	U4/SM
	27	30	66	2750	0,2	170	G 1/2	U2
	50	50	110	5100	0,2	1000	G 1	U1
	19	21	48	800	0,2	75	G 1/4	U4/SM2

SLIDE VALVES SERIES VC

TECHNICAL DATA

Operating pressure	0 ÷ 16 bar
Working temperature	0 ÷ +80° C (-10° C with dry air)
Fluid	Compressed air, filtered, continuous lubricated, unlubricated or dry lubricated
Port size	G 1/8 - G 1/4 - G 3/8 - G 1/2

MATERIALS

Body	Nickel-plated brass
Slide	Anodized aluminium
Seals	NBR rubber

DIMENSIONS AND WEIGHTS VC

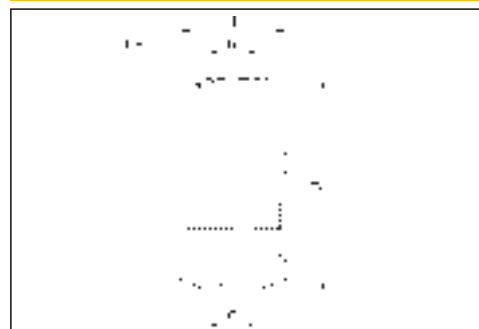

CH	B	Flow rate at 6 bar ΔP=1 bar (NI/min)	D	Weight (g)	G	TYPE
14	25	700	48	54	G 1/8	VC-01
17	30	1500	58	102	G 1/4	VC-02
22	35	2200	68	153	G 3/8	VC-03
27	40	3400	80	204	G 1/2	VC-04

DISTRIBUTION FRAMES SERIES RX

TECHNICAL DATA

Fluid	Air, oil, water
Port size	G 1/8 - G 1/4 - G 3/8 - G 1/2

MATERIALS

Body	Anodized aluminium alloy
------	--------------------------

B	C	D	E	F	G	H	A	Weight (g)	TYPE
31	23	22	4,5	4	4,3	16	G 1/8	35	RX8
40	30	27	6,5	5	5,3	20	G 1/4	70	RX4
50	38	39	5,5	6	6,3	25	G 3/8	130	RX3
50	38	39	5,5	6	6,3	25	G 1/2	115	RX2

DIMENSIONS AND WEIGHTS RX

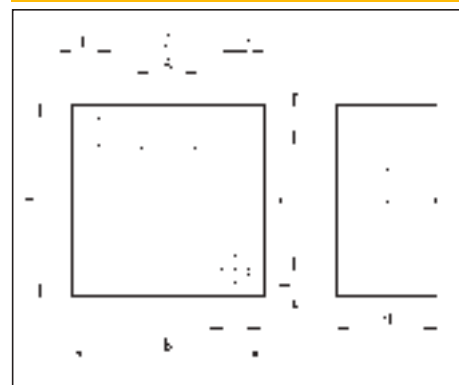

DIMENSIONS AND WEIGHT RX8/6

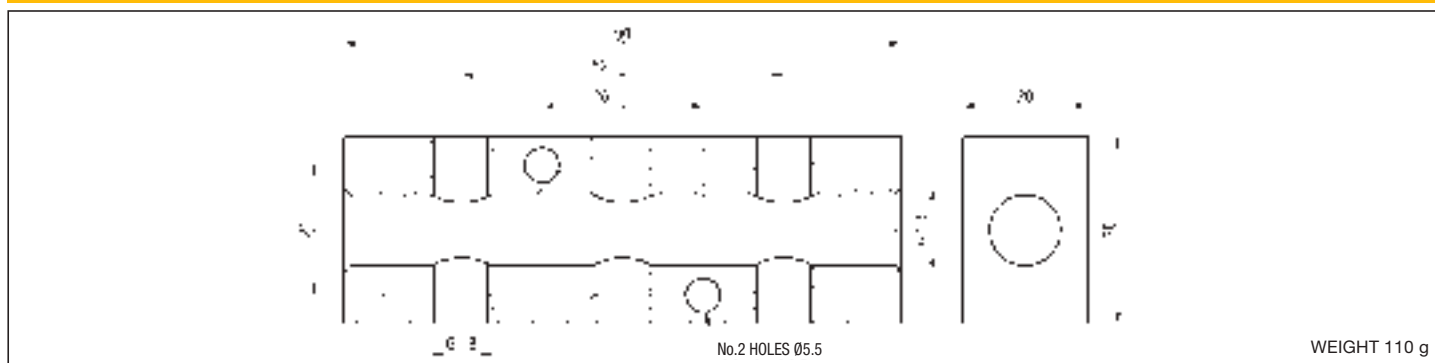

DESCRIPTION

Pneumatic logic elements series "EL" are produced in the following No.5 basic functions: OR, AND, YES, NOT and MEMORY, with push-in fittings for pipe Ø 4 mm, and the pressure indicator is on body valve as standard. These elements can be mounted both separately (line mounted thanks to the No.2 holes on body valve) than on manifold bracket. The pneumatic logic element NOT is a threshold component and the pressure triggering value is 0,6 bar (at 6 bar). They are in compliance with ATEX directive, 2GD category, upon request.

TECHNICAL DATA

Operating pressure	1,5 ÷ 10 bar
Working temperature	0 ÷ +60 °C (-20 °C with dry air)
Fluid	Compressed air, filtered, continuous lubricated, unlubricated or dry lubricated
Port size	Push-in fittings for pipe Ø 4 mm
Rated flow rate	90 NI/min

MATERIALS

Body	Anodized aluminium alloy
Bushing and guide	Nickel - plated brass
Springs	Stainless steel
Seals	NBR rubber
Spool	Anodized aluminium alloy
Connections	Nickel - plated brass, plastic material

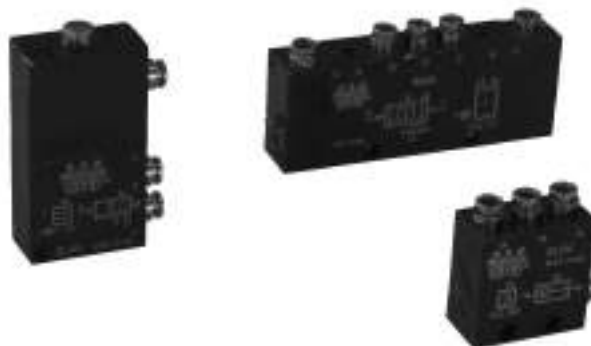

LOGIC ELEMENT - ELO4 (OR - logical sum)*

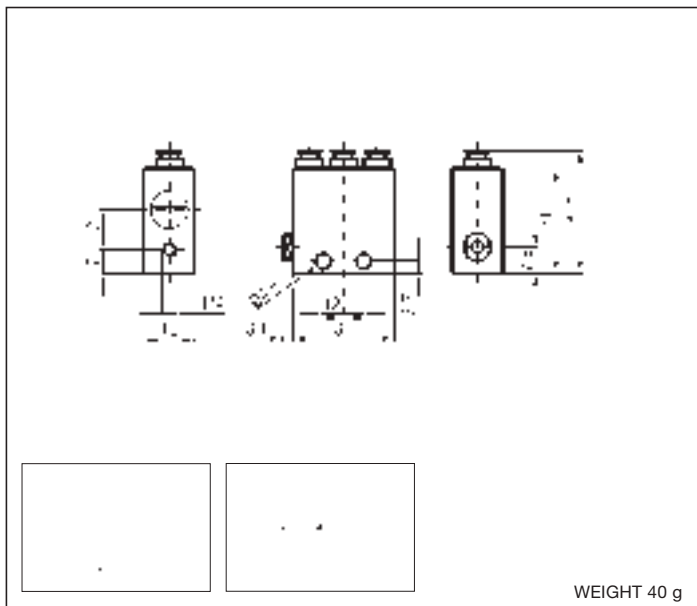

LOGIC ELEMENT - ELA4 (AND - logical multiplication)*

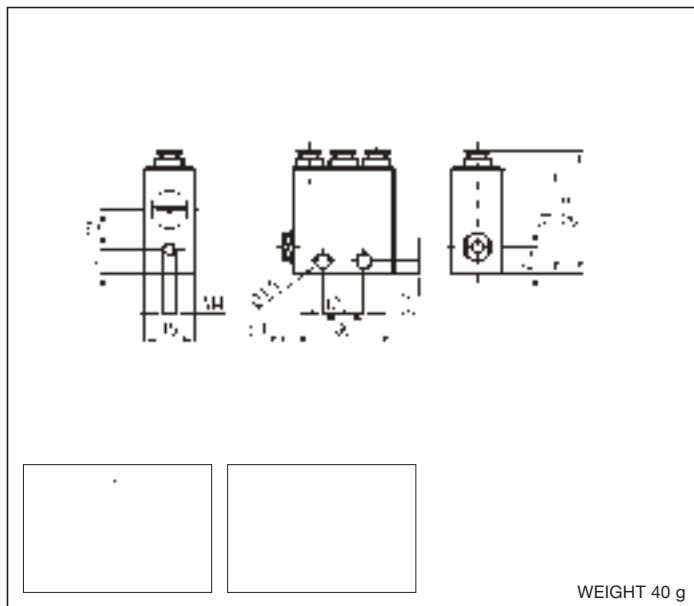

*EX Consistent with the ATEX directive  II 2GD c T5 T100°C -20°C ≤ Ta ≤ 60°C E.G.: **ELO4/EX**

LOGIC ELEMENT - ELY4 (YES - affirmation)*

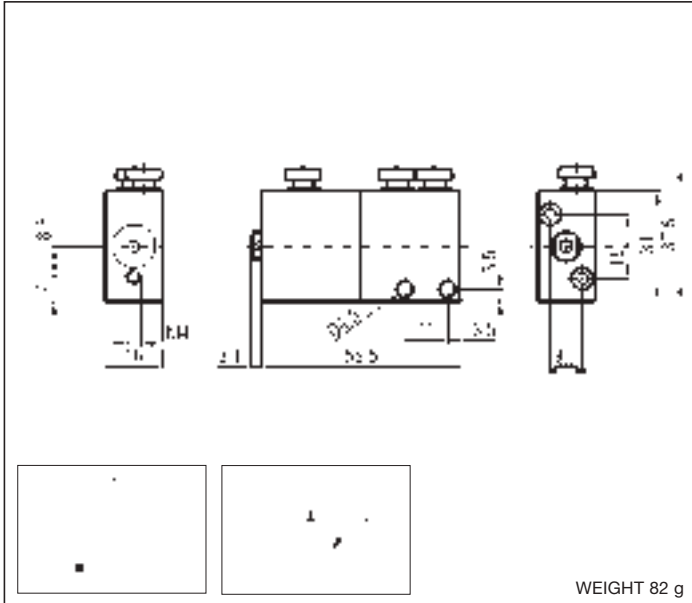

LOGIC ELEMENT - ELN4 (NOT - negation)*

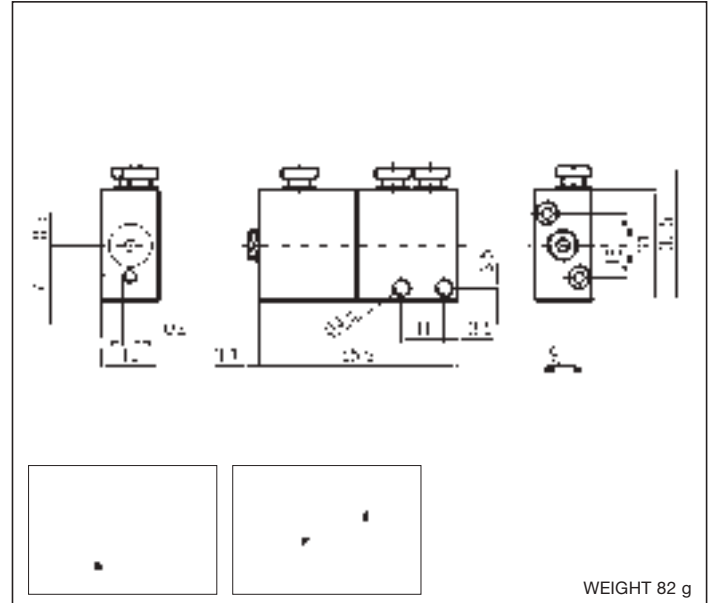

LOGIC ELEMENT - ELM4 (memory)*

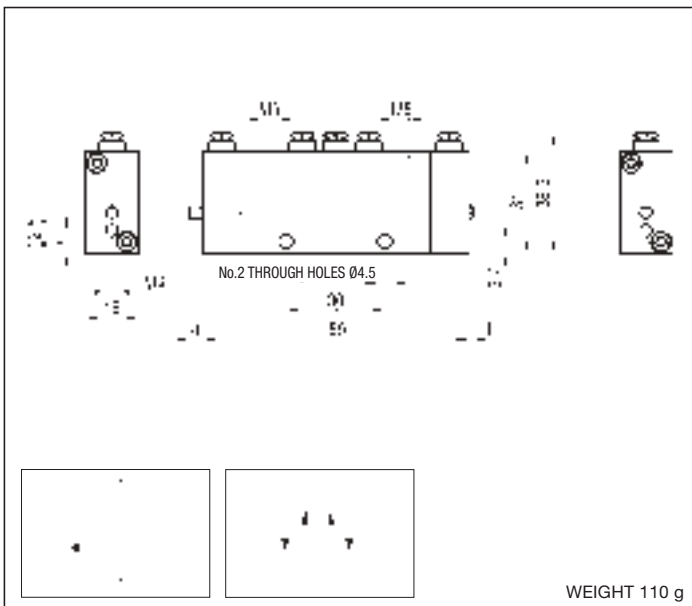

BRACKET - ELSQ

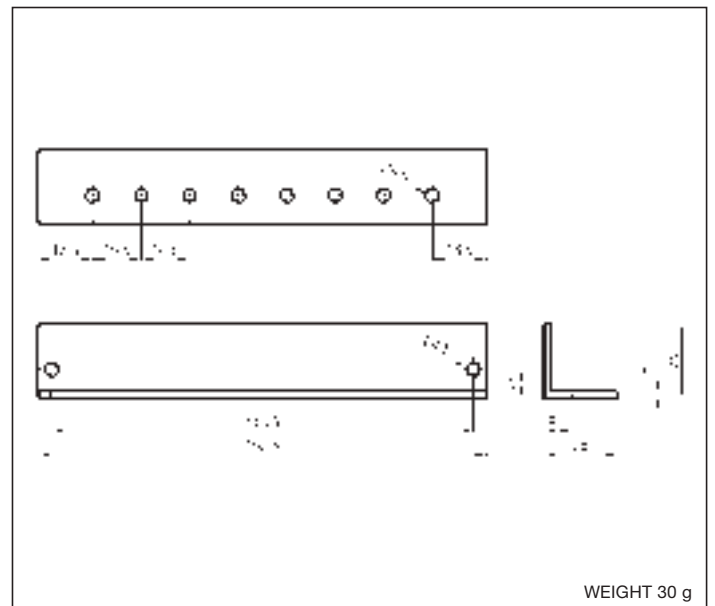

*EX Consistent with the ATEX directive II 2GD c T5 T100°C -20°C ≤ Ta ≤ 60°C E.G.: ELY4/EX

DESCRIPTION

Flow regulators series "UR" are produced in three different versions, unidirectional (type "URG") - bi-directional (type "URF"), to have a precision in-line regulation; unidirectional (type "URE"), when it's necessary a standard in-line regulation with reduced dimensions, and in the silenced exhaust version (type "URS"). In-line precision flow regulators type "URG"- "URF" are available in different adjustment scale in the size G 1/8 (see the flow charts).



3

IN-LINE PRECISION FLOW REGULATORS TYPE URG - URF

TECHNICAL DATA

Operating pressure	0 ÷ 12 bar
Working temperature	0 ÷ +80 °C (-20 °C with dry air)
Fluid	Compressed air, filtered, continuous lubricated, unlubricated or dry lubricated
Port size	G 1/8 - G 1/4 - G 1/2

MATERIALS

Body	Anodized aluminium alloy
Seals	NBR rubber
Regulation needle	Aluminium (stainless steel for "URG" - "URF 8/1")
Needle guide	Brass
Nuts	Brass

FLOW CHART AT 6 BAR - UR 8/1

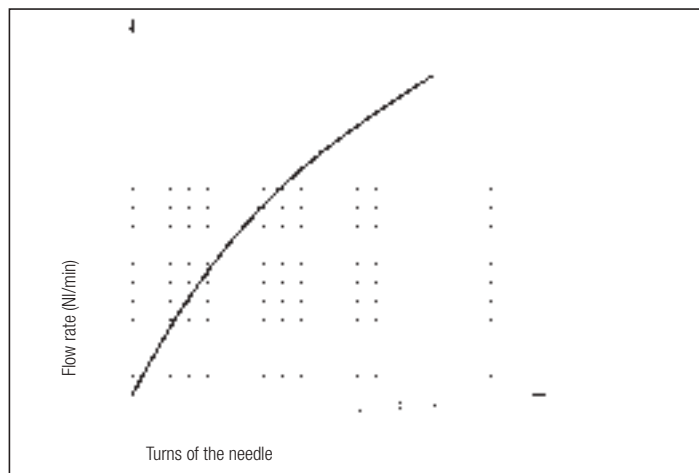

FLOW CHART AT 6 BAR - UR 8/2

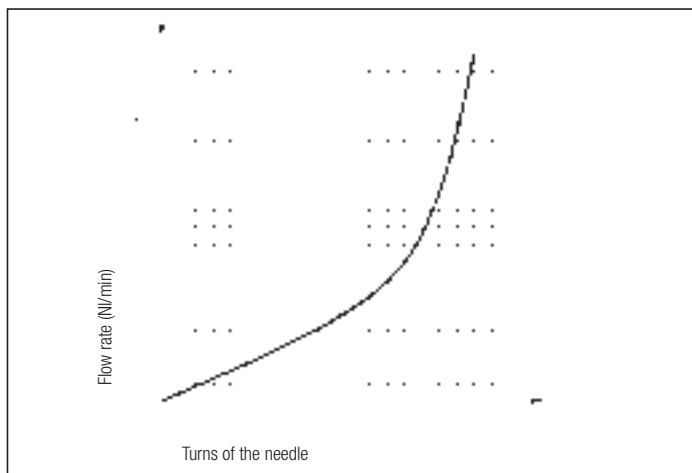

FLOW CHART AT 6 BAR - UR 8/5

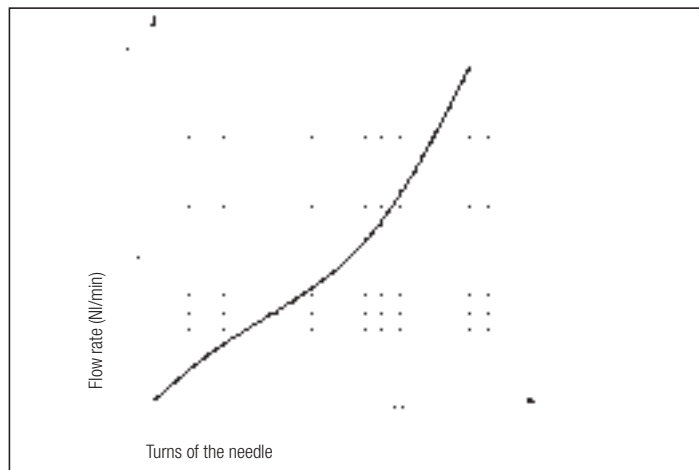

FLOW CHART AT 6 BAR - UR 4/10

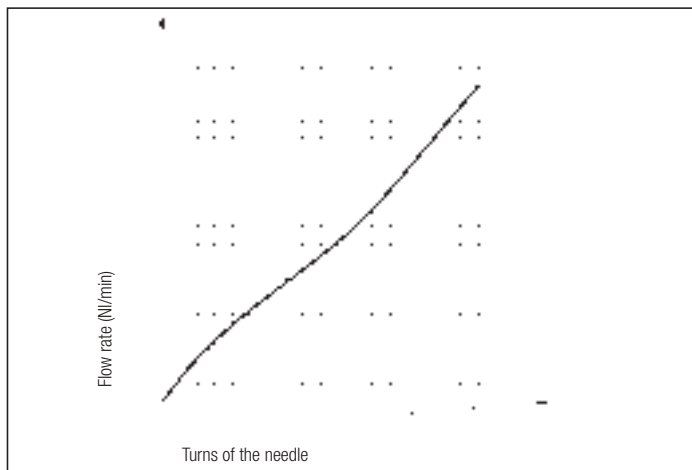

FLOW CHART AT 6 BAR - UR 2/25

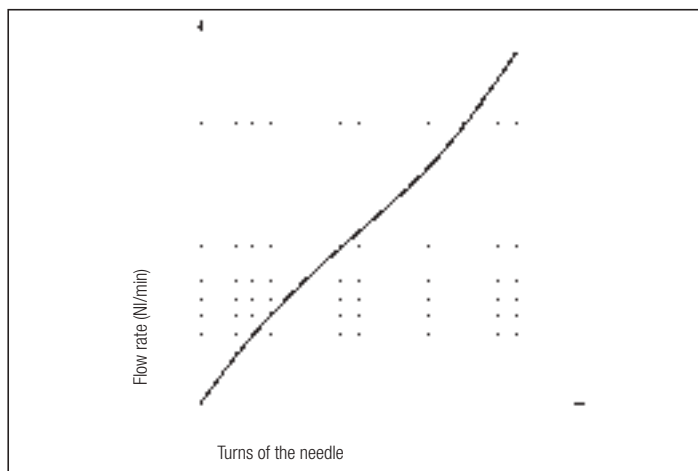

Symbol	Nominal diameter (mm)	Port size	TYPE
URG8	0,9	G 1/8	URG8/1
	2	G 1/8	URG8/2
	5	G 1/8	URG8/5
	7,2	G 1/4	URG4/10
URF2	12	G 1/2	URF2/25
	0,9	G 1/8	URF8/1
	2	G 1/8	URF8/2
	5	G 1/8	URF8/5
	7,2	G 1/4	URF4/10
	12	G 1/2	URF2/25

DIMENSIONS AND WEIGHTS URG - URF

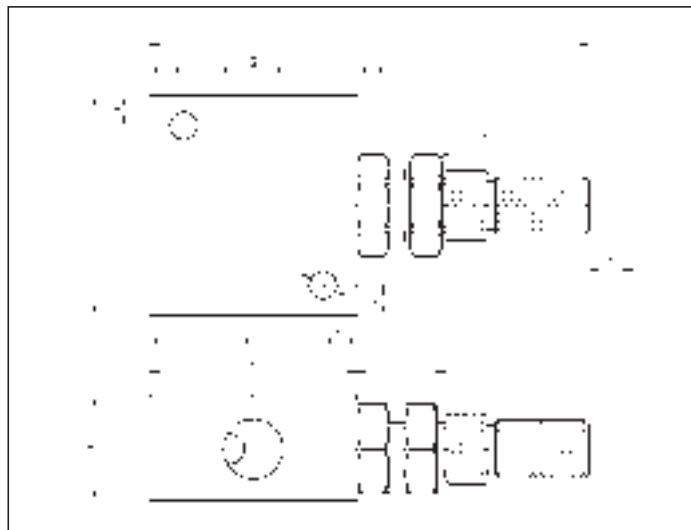

A	B	C	CH	D	E	F	H
6	M12x0,75	4	14	12,5	31	4,5	5,5
8,5	M15x0,75	5,5	17	17	40	6,5	6
13	M25x1,5	7	30	22	65	8,5	12,5
I	L	N	O	S	Weight (g)	G	TYPE
4,3	34	16	15,5	65	60	G 1/8	
5,25	42	20	20	84,5	120	G 1/4	
6,25	69	35	32,5	127	540	G 1/2	

IN LINE STANDARD FLOW REGULATORS TYPE URE

Symbol	A	B	C	CH	D	E	F1	F2	H
URE8	10	M12X0,75	3	14	11	25	7	5	4
	13	M15X0,75	5	23	16	45	6,5	6,5	6,5
	I	L	N	O1	O2	S	Weight (g)	G	TYPE
	4,5	31	16	8,5	17	55	55	G 1/8	URE8
	5,3	56	25	13,5	26	88,5	101	G 1/2	URE2

DIMENSIONS AND WEIGHTS URE



SILENCED EXHAUST FLOW REGULATORS TYPE URS

TECHNICAL DATA

Operating pressure	0 ÷ 12 bar
Working temperature	0 ÷ +80° C (-20° C with dry air)
Fluid	Compressed air, filtered, continuous lubricated, unlubricated or dry lubricated
Port size	G 1/8 - G 1/4 - G 3/8 - G 1/2

MATERIALS

Body	Brass
Silencer	Sintered bronze
Seals	NBR rubber

DIMENSIONS AND WEIGHTS URS

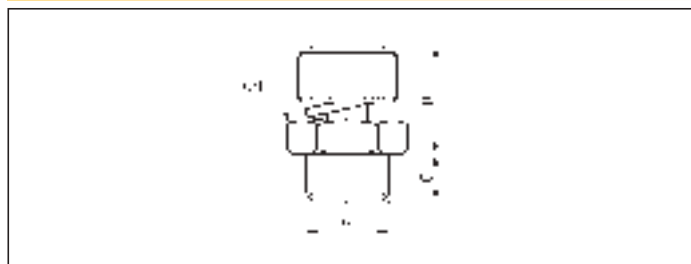

Symbol	B	C	CH	Weight (g)	G	TYPE
URS	15,5	6	12	15	G 1/8	URS8/3
	17,5	8	16	25	G 1/4	URS4/5
	20	9	20	40	G 3/8	URS3/7
	22,5	10,5	22	70	G 1/2	URS2/9

DESCRIPTION

Block valves series "WB" are produced in the 2/2 - G 1/8, G 1/4 and G 1/2 monostable pneumatic functions in both the uni- and bi-directional versions. The working of the block valve consists in avoiding unexpected depressurisation of the cylinder's chamber due to lack of compressed air at the piloting port. For a correct functioning of the block valves we suggest to mount them directly on the cylinder.



3

TECHNICAL DATA

Operating pressure	0 ÷ 10 bar
Minimum piloting pressure (at 10 bar)	G 1/8 = 2,5 bar G 1/4 = 4 bar G 1/2 = 5 bar
Working temperature	0 ÷ +70 °C (-10 °C with dry air)
Fluid	Compressed air, filtered, continuous lubricated, unlubricated or dry lubricated
Port size	G 1/8 - G 1/4 - G 1/2
Pneumating piloting port size	G 1/8
Nominal diameter	G 1/8 = 5 mm G 1/4 = 7 mm G 1/2 = 12 mm
Flow rate at 6 bar (with ΔP = 1 bar)	G 1/8 = 500 NI/min G 1/4 = 700 NI/min G 1/2 = 1900 NI/min

MATERIALS

Control rod	Anodized aluminium alloy
Body	Anodized aluminium alloy
Spring	Stainless steel
End plug	Nick-plated brass
Seals	NBR rubber
Washer	Brass

SPARE PARTS

SEALS KIT	
G 1/8	WB/SG/8
G 1/4	WB/SG/4
G 1/2	WB/SG/2

DIMENSIONS AND WEIGHTS

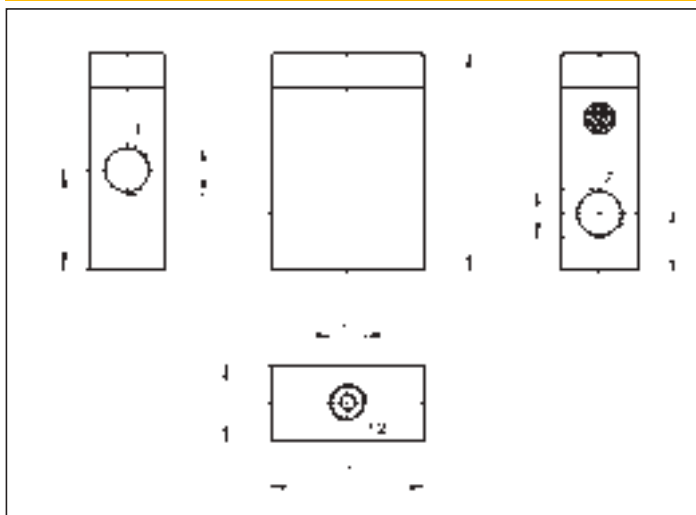

Symbol	A	B	C	H	I	P	Weight (g)	G	TYPE
.	31	16	47	21,5	11,5	G 1/8	61	G 1/8	WB8U
	40	20	57	26,5	15		120	G 1/4	WB4U
	50	25	69	34,5	18		220	G 1/2	WB2U
.	31	16	47	21,5	11,5	G 1/8	61	G 1/8	WB8B
	40	20	57	26,5	15		120	G 1/4	WB4B
	50	25	69	34,5	18		220	G 1/2	WB2B

DESCRIPTION OF THE CONNECTION

1 = INPUT
2 = CYLINDER
12 = PILOTING

DESCRIPTION

The type "XVF4" identifies a 3/2 N.C. amplifier valve that changes low pressure signals into pneumatic signals (1 ÷ 8 bar). Valve type "XVF5" is instead a 3/2 N.O. amplifier valve that changes negative pneumatic signals into pneumatic signals (1 ÷ 7 bar). Both of them are suitable to pilot directly the valves series "UDS" and "UK" with the same mounting than solenoid valves series "UL". For single mounting there is the sub-base type "XVB" (see on page 2.11) while for manifold mounting there are the bases type "ULP" (see on page 2.10).



TECHNICAL DATA

Operating pressure	XVF4: 1 ÷ 8 bar XVF5: 1 ÷ 7 bar
Working temperature	0 ÷ +60 °C (10 °C)
Fluid	Compressed air, filtered, continuous lubricated, unlubricated or dry lubricated
Piloting pressure	XVF4: 500 mbar XVF5: -500 mbar
Maximum frequency	50 Hz
Flow rate	500 NI/min a 6 bar
Controlled leakage consumption	1,4 NI/min a 7 bar
Piloting hole	M5

MATERIALS

Control rod	Aluminium
Body	Anodized aluminium alloy
Springs	Phosphor bronze
Seals	NBR rubber
Washer	Aluminium
Fixing screws	White galvanized steel

DIMENSIONS - XVF

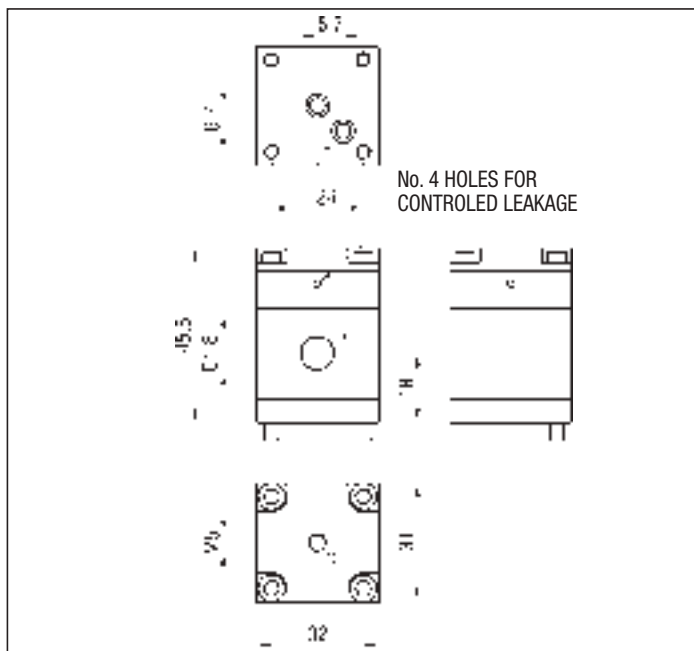

SPARE PARTS

SEALS KIT	
XVF	XVF/SG/4-5

FLOW CHART - XVF

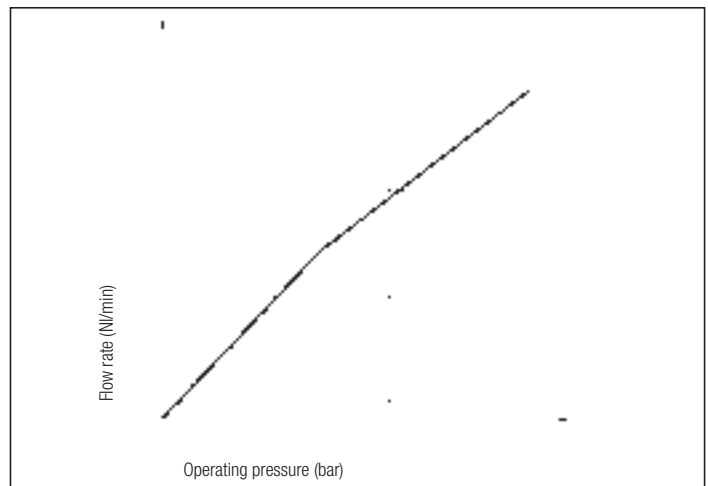

3 PORT

Symbol	Function	Controls		Response times at 6 bar (ms)		Flow rate at 6 bar ΔP = 1 bar (NI/min)	Weight (g)	TYPE
		Pilot	Return	Pilot	Return			
	3/2 N.C.	Pneumatic	Mechanical spring	26,64	38,42	500	10,5	XVF4
	3/2 N.O.	Vacuum	Mechanical spring	21,14	32,66	500	10,5	XVF5



Max 10 bar
E222PM
Max 10 bar

Max 10 bar
E222PM-5M
Max 10 bar
E222PT
Max 10 bar

Max 10 bar
E222PM
Max 10 bar

Max 10 bar
E222PM-5M
Max 10 bar
E222PT

Series UZ

Filter UZF G 1/4.....	page	4.2
Pressure reducer UZRR G 1/4.....	page	4.3
Filter reducer UZRRM /F G 1/4.....	page	4.4
Lubricator UZL G 1/4.....	page	4.5
Soft-start valve UZAP G 1/4.....	page	4.6
Automatic soft-start valve UZAP /A4 G 1/4.....	page	4.7
Shut - off valve UZVL G 1/4.....	page	4.7
Filter reducer + lubricator G 1/4.....	page	4.8
Filter + reducer + lubricator G 1/4.....	page	4.9
Accessories: mounting brackets.....	page	4.10
intermediate air intake.....	page	4.10
assembling screws.....	page	4.10
Example of assembly.....	page	4.10

Series RRP

Precision pressure reducer RRP G 1/4.....	page	4.11
---	------	------

Series EZ

Filter EZF G 3/8 - G 1/2 - G 1.....	page	4.12
Pressure reducer EZRR G 3/8 - G 1/2 - G 1.....	page	4.14
Filter reducer EZRR /F G 3/8 - G 1/2 - G 1.....	page	4.16
Lubricator EZL G 3/8 - G 1/2 - G 1.....	page	4.18
Soft-start valve EZAP G 3/8 - G 1/2 - G 1.....	page	4.20
Shut - off valve EZVL G 3/8 - G 1/2 - G 1.....	page	4.22
Filter reducer + lubricator G 3/8 - G 1/2 - G 1.....	page	4.23
Filter + reducer + lubricator G 3/8 - G 1/2 - G 1.....	page	4.24
Accessories: mounting brackets.....	page	4.25
intermediate air intake.....	page	4.25
assembling screws.....	page	4.25
Example of assembly.....	page	4.25

Series EPR

Pressure proportional valves G 1/8 - G 1/4 - G 1/2.....	page	4.26
Accessories: flanges.....	page	4.29
connectors.....	page	4.29

Series MA

Air treatment accessories: manometers.....	page	4.30
--	------	------

Series PR

Air treatment accessories: digital/analog pressure switch series PRDA.....	page	4.31
Air treatment accessories: diaphragm pressure switch series PRC-PRA.....	page	4.32
Air treatment accessories: contacts exchange pressure switch series PRCA.....	page	4.33

DESCRIPTION

Filters series "UZF" are produced with connections G 1/4; they are available with various degrees of filtration and with manual or semi-automatic condensate drainage system. The techno-polymer bowls can carry a metallic protection or being entirely metallic (without visualization of level). They are in compliance with ATEX directive, 2GD category, upon request.

TECHNICAL DATA

Maximum pressure	16 bar
Working temperature	0 ÷ +50 °C (-10 °C with dry air)
Fluid	Compressed air
Port size	G 1/4
Void fraction	20 µm standard, 5 µm and 40 µm upon request
Condensate drainage system	Manual or semi-automatic
Max. condensate capacity	9 cm ³ (do not exceed the level gauge)
Type of mounting	Modular, in-line and wall-mounting
Wall clamping screws	M4x50



MATERIALS

Body	Aluminium alloy
Bowl	Transparent techno-polymer with metallic protection or entirely metallic bowl (without visualization of level)
Filtering element	Sintered polyethylene 5 µm - orange 20 µm - white 40 µm - grey
Seals	NBR rubber
Baffle	Acetal resin

4

DIMENSIONS AND WEIGHT - UZF G 1/4

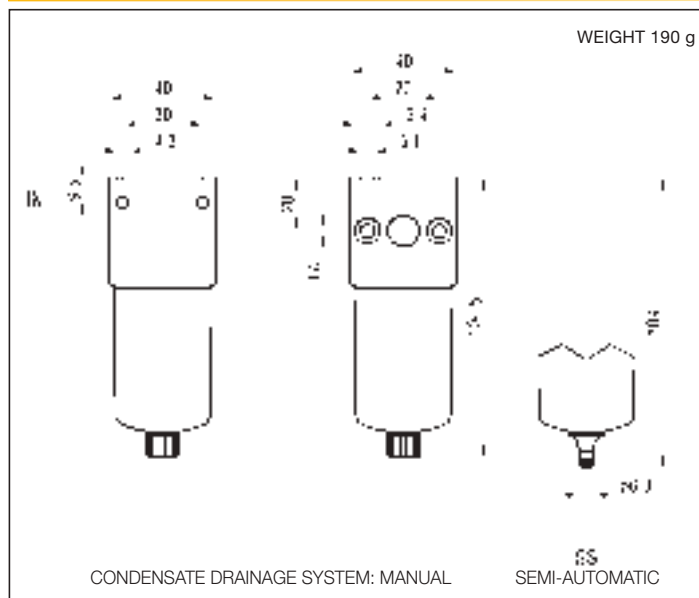

FLOW CHART - UZF

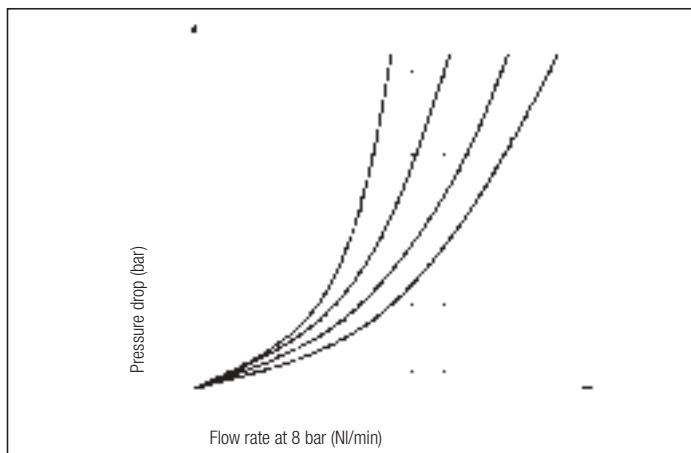

ORDER KEY

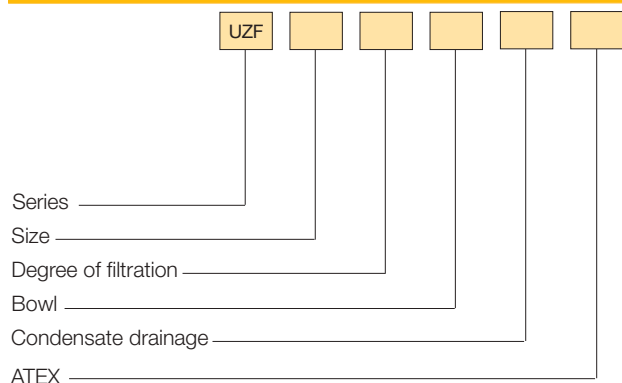

SPARE PARTS

Metallic protection	UZ/PM
Metallic bowl with manual drain	UZ/TM/R
Metallic bowl with semi-automatic drain	UZ/TM/R/SS
Techno-polymer bowl with manual drain	UZ/SG/3
Techno-polymer bowl with semi-automatic drain	UZ/SG/3/SS
Filter cartridge 5 µm	UZ/SG/1
Filter cartridge 20 µm	UZ/SG/2
Filter cartridge 40 µm	UZ/SG/4

SIZE

4 G 1/4

DEGREE OF FILTRATION

/5 5 µm /20 20 µm
/40 40 µm

BOWL

Transparent PM Metallic protection
TM Metallic

CONDENSATE DRAINAGE SYSTEM

Manual /SS Semi-automatic

ATEX

/EX Consistent with the ATEX directive II 2GD c T5 T100°C -10°C ≤ Ta ≤ 50°C*

Air treatment: pressure reducer UZRR G 1/4

series UZ

DESCRIPTION

Reducers series "UZRR" are produced in two different models: type UZRRH, fit for in-line or panel mounting and type UZRRM, fit for panel mounting or modular assembly (with filter and lubricator). Both the two models are available with different scales of regulation and with connections G 1/4. They are in compliance with ATEX directive, 2GD category, upon request.

TECHNICAL DATA

Maximum pressure	16 bar
Working temperature	0 ÷ +50 °C (-10 °C with dry air)
Fluid	Filtered, lubricated and unlubricated compressed air
Port size	G 1/4
Pressure gauge port size	G 1/8
Adjusting range (bar)	0,2 ÷ 2 - 0,4 ÷ 4 - 0,8 ÷ 9 - 1,5 ÷ 12
Type of mounting	Modular, in-line, wall and panel mounting
Wall clamping screws	M4x50



DIMENSIONS AND WEIGHT - UZRRM G 1/4

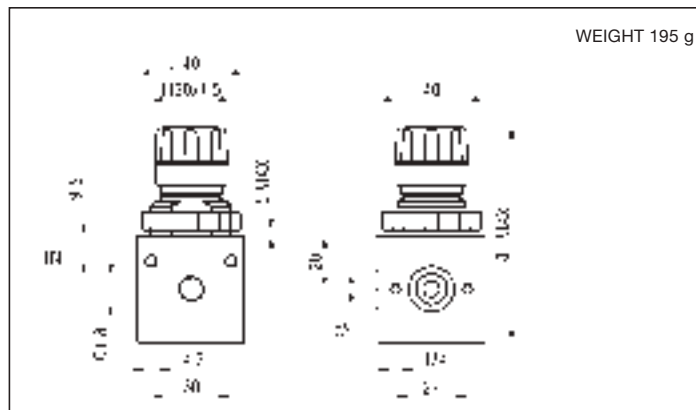

DIMENSIONS AND WEIGHT - UZRRH G 1/4

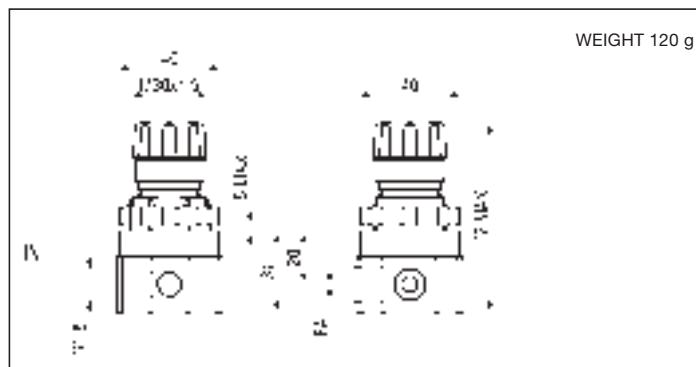

ORDER KEY

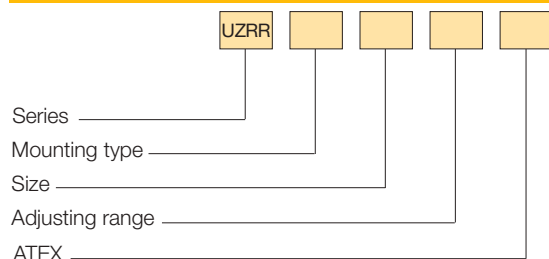

SPARE PARTS

Relieving kit adjustment	UZRR/SG/6
Non-relieving kit adjustment	UZRR/SG/5

MATERIALS

Body	Aluminium alloy
Closing plug	Brass, NBR rubber
Spring	Stainless steel
Knob	Acetal resin
Adjusting screw	Brass
Diaphragm	Brass, NBR rubber

FLOW CHART - UZRR

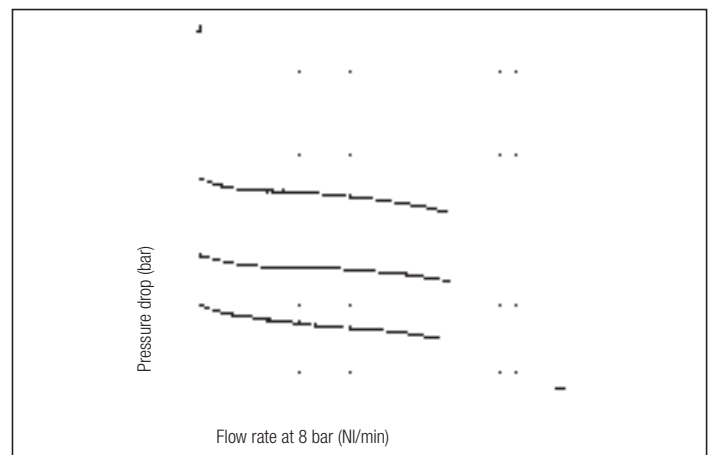

MOUNTING TAPE

H For panel mounting M Modular

SIZE

4 G 1/4

ADJUSTING RANGE

/3 0,2 ÷ 2 bar /5 0,4 ÷ 4 bar
/7 0,8 ÷ 9 bar /12 1,5 ÷ 12 bar

ATEX

/EX Consistent with the ATEX directive II 2GD c T5 T100°C -10°CsTas50°C

P.S.: Reducers can be supplied without the relieving seal on request; the series becomes **UZR**...

series UZ

Air treatment: filter reducer UZRRM /F G 1/4

DESCRIPTION

Filter reducer series "UZRRM/F", produced with connections G 1/4, combine the characteristics of the filters and of the pressure reducers "UZ", thus optimising the overall dimension. They are in compliance with ATEX directive, 2GD category, upon request.

TECHNICAL DATA

Maximum pressure	16 bar
Working temperature	0 ÷ +50 °C (-10 °C with dry air)
Fluid	Compressed air
Port size	G 1/4
Pressure gauge port size	G 1/8
Void fraction	20 µm standard, 5 µm and 40 µm on request
Condensate drainage system	Manual or semi-automatic
Max. condensate capacity	9 cm ³ (do not exceed the level gauge)
Adjusting range (bar)	0,2 ÷ 2 - 0,4 ÷ 4 - 0,8 ÷ 9 - 1,5 ÷ 12
Type of mounting	Modular, in-line, wall and panel mounting
Wall clamping screws	M4x50



MATERIALS

Body	Aluminium alloy
Bowl	Transparent techno-polymer with metallic protection or entirely metallic bowl (without visualization of level) on request
Filtering element	Sintered polyethylene 5 µm - orange 20 µm - white 40 µm - grey
Seals	NBR rubber
Baffle	Acetal resin
Closing plug	Brass, NBR rubber
Spring	Stainless steel
Knob	Acetal resin
Adjusting screw	Brass
Diaphragm	Brass, NBR rubber

FLOW CHART - UZRRM /F

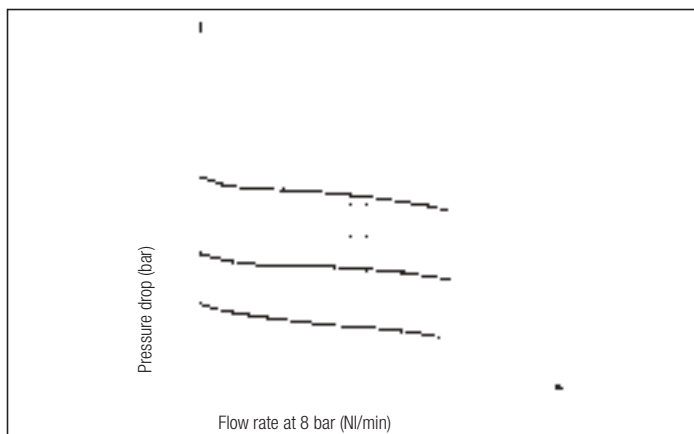

4

DIMENSIONS AND WEIGHT - UZRRM /F

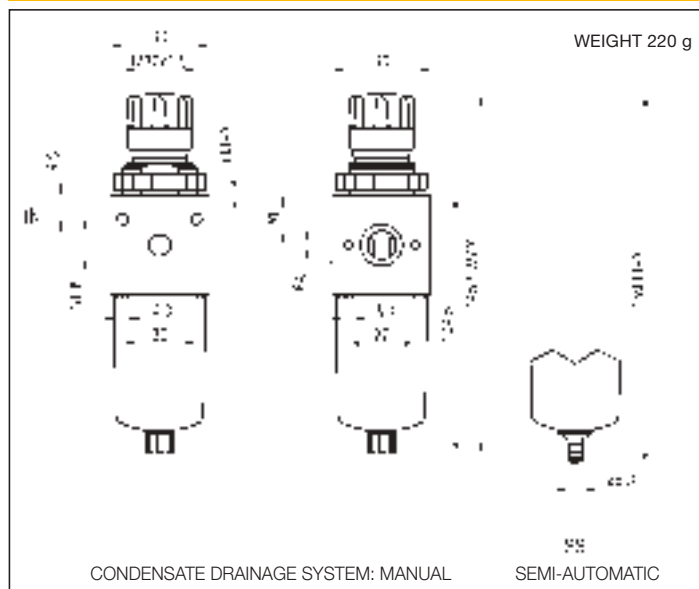

SPARE PARTS

See series "UZF" (on page 4.3) and "UZRR" (on page 4.4)

ORDER KEY

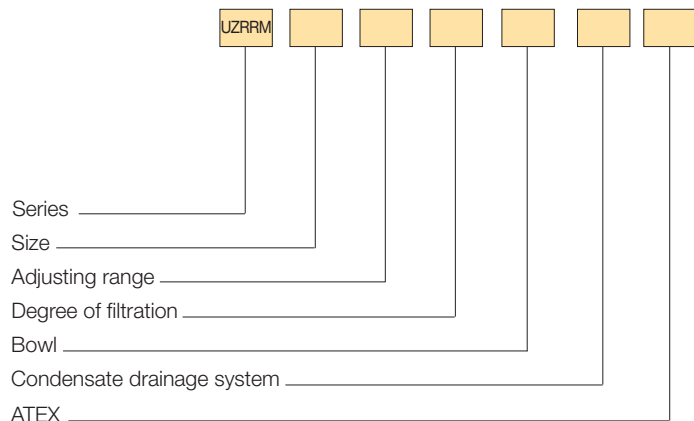

P.S.: Filters reducers can be supplied without the relieving seal on request; the series becomes **UZRM**...

SIZE

4 G 1/4

ADJUSTING RANGE

/3 0,2 ÷ 2 bar /5 0,4 ÷ 4 bar
/7 0,8 ÷ 9 bar /12 1,5 ÷ 12 bar

DEGREE OF FILTRATION

F5 5 µm F20 20 µm
F40 40 µm

BOWL

Transparent PM Metallic protection
TM Metallic

CONDENSATE DRAINAGE SYSTEM

Manual /SS Semi-automatic

ATEX

/EX Consistent with the ATEX directive II 2GD c T5 T100°C -10°C ≤ Ta ≤ 50°C*

Air treatment: lubricator UZL G 1/4

series UZ

DESCRIPTION

Lubricators series "UZL" are produced with connections G 1/4; the techno-polymer bowls can carry a metallic protection or being entirely metallic (without visualization of level). For a correct lubrication it is advisable to set the drip rate in order to have a drop of oil WAIRSOL class ISO15 every 300 - 500 NI/min. They are in compliance with ATEX directive, 2GD category, upon request.

TECHNICAL DATA

Maximum pressure	16 bar
Working temperature	0 ÷ +50 °C (-10 °C with dry air)
Fluid	Filtered compressed air
Port size	G 1/4
Bowl capacity	20 cm ³ (do not exceed the level gauge)
Type of mounting	Modular, in-line and wall-mounting
Wall clamping screws	M4x50
Minimum striking flow rate	20 NI/min

DIMENSIONS AND WEIGHT - UZL

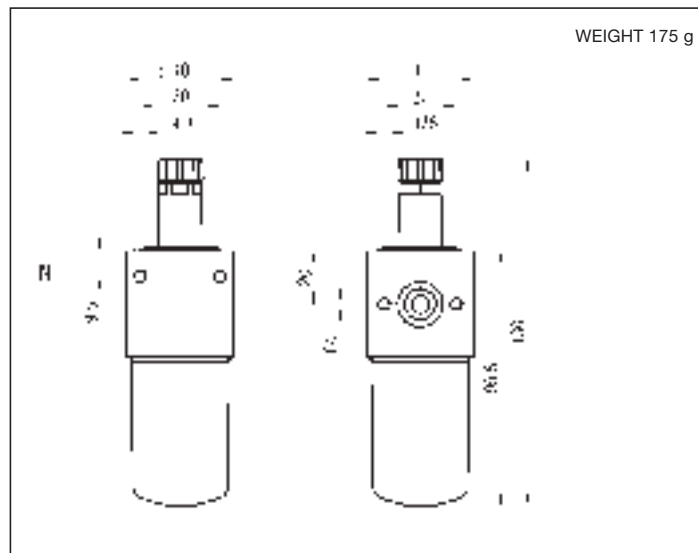

ORDER KEY

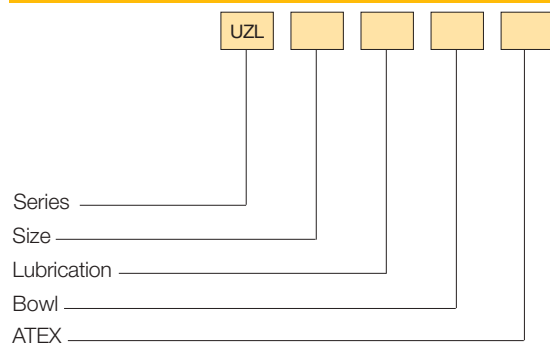

MATERIALS

Body	Aluminium alloy
Bowl	Transparent techno-polymer with metallic protection or entirely metallic bowl (without visualization of level) on request
Seals	NBR rubber
Conduits	Acetal resin

FLOW CHART - UZL

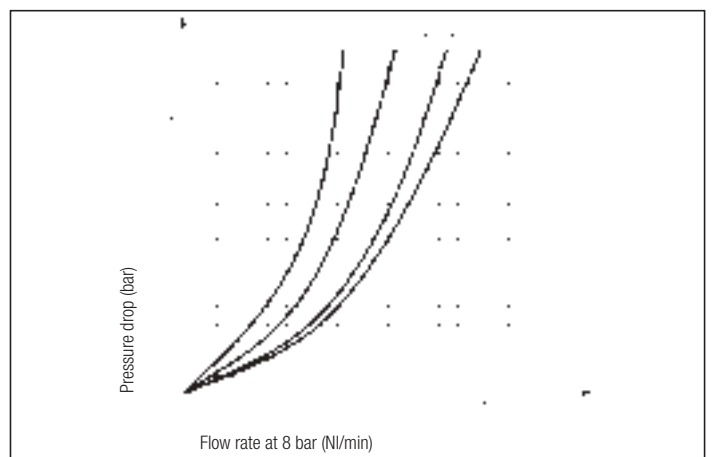

SIZE

4 G 1/4

LUBRICATION

Oil-mist **M** Micro oil-mist

BOWL

Transparent **PM** Metallic protection

TM Metallic

ATEX

/EX Consistent with the ATEX directive II 2GD c T5 T100°C -10°C ≤ Ta ≤ 50°C*

SPARE PARTS

Metallic protection	UZ/PM
Metallic bowl	UZL/TM
Techno-polymer bowl	UZL/SG/3
Clear flow indicator	UZL/SG/4

DESCRIPTION

SOFT-START VALVE: soft-start valves series “UZAP” are produced with connections G 1/4 in the pneumatic and solenoid actuated versions. The working of the soft-start valve consists in feeding gradually air into the circuit with adjustable flow. When the pressure in the circuit reaches the 50 ÷ 60% of the upstream set pressure, the valve switches to full capacity, supplying the circuit with the maximum flow rate. They are in compliance with ATEX directive, 2GD category, upon request.



TECHNICAL DATA

Maximum pressure	10 bar
Working temperature	0 ÷ +50 °C (-10 °C with dry air)
Fluid	Filtered, unlubricated or continuous lubricated compressed air
Port size	G 1/4
Piloting port size	G 1/8
Flow rate at 6 bar ΔP=1 bar	500 NI/min (750 NI/min for type UZAP/A4)
Max. flow rate of the adjusting screw of the filling time	300 NI/min
Type of mounting	Modular, in-line and wall-mounting
Wall clamping screws	M4x50
Piloting solenoid valve	C/USCSVP - see chapter Direct acting solenoid valves on page 2.14
Coil	USB - see chapter Coils on page 2.17 USBG - see chapter Coils on page 2.17 USBG2 - see chapter Coils on page 2.17
Electric connector	USR 102/N9 - see chapter Connectors on page 2.18 ULR1B - see chapter Connectors on page 2.18

MATERIALS

Body	Anodized aluminium alloy
Springs	Stainless steel
Pistons	Anodized aluminium alloy
Seals	NBR rubber

ORDER KEY

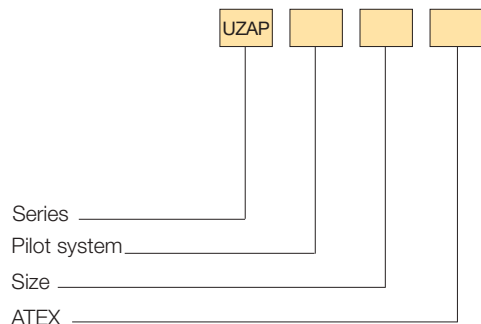

PILOT SYSTEM

/R Pneumatic /U Solenoid

SIZE

4 G 1/4

ATEX

/EX Consistent with the ATEX directive II 2GD c T5 T100°C -10°C≤Ta≤50°C

DIMENSIONS AND WEIGHT - UZAP/R4

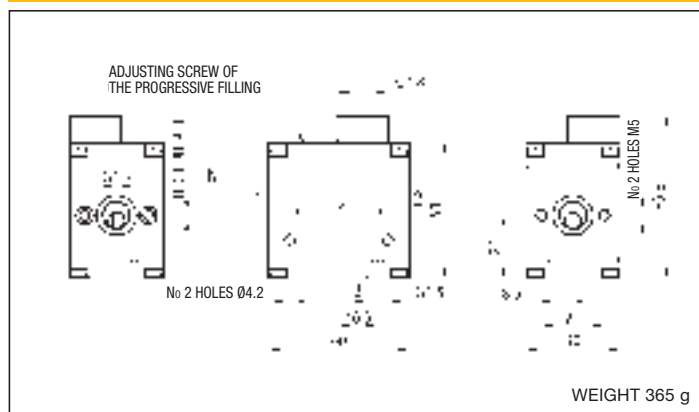

DIMENSIONS AND WEIGHT - UZAP/U4

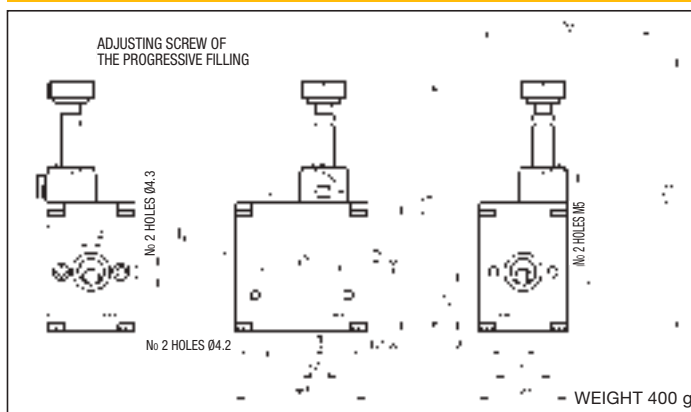

Air treatment: automatic soft-start valve UZAP/A4 G 1/4

series UZ

DESCRIPTION

AUTOMATIC SOFT-START VALVE: this valve, produced with connections G 1/4 in the 2/2 pneumatic version, even if cannot be modular assembled with the F-R-L of series "UZ", yet assures the same functionality of the soft-start valve before mentioned, and with the peculiarity of being "automatic", not needing any kind of external pilot. They are in compliance with ATEX directive, 2GD category, upon request.

DIMENSIONS AND WEIGHT - UZAP/A4

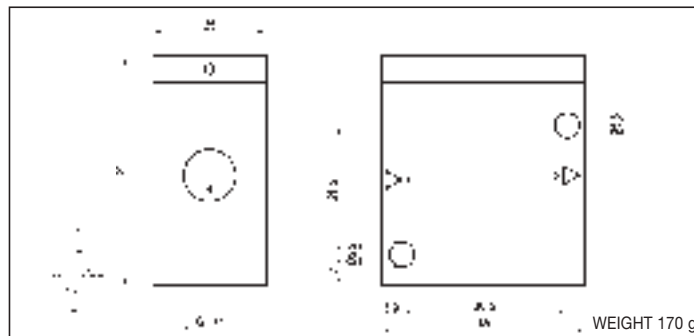

4

Air treatment: shut - off valve UZVL G 1/4

series UZ

DESCRIPTION

Shut - off valves series "UZVL" are produced with connections G 1/4 and they are fit to be locked in the exhaust position by means of a standard padlock. It is in compliance with ATEX directive, 2GD category, upon request.



TECHNICAL DATA

Maximum pressure	16 bar
Working temperature	0 ÷ +50 °C (-10° C with dry air)
Fluid	Filtered, unlubricated or continuous lubricated compressed air
Port size	G 1/4
Flow rate at 6 bar ΔP=1 bar	1300 NI/min
Type of mounting	Modular and in-line

MATERIALS

Body	Anodized aluminium alloy
Seals	NBR rubber
Slider	Anodized aluminium alloy

DIMENSIONS AND WEIGHT - UZVL/4

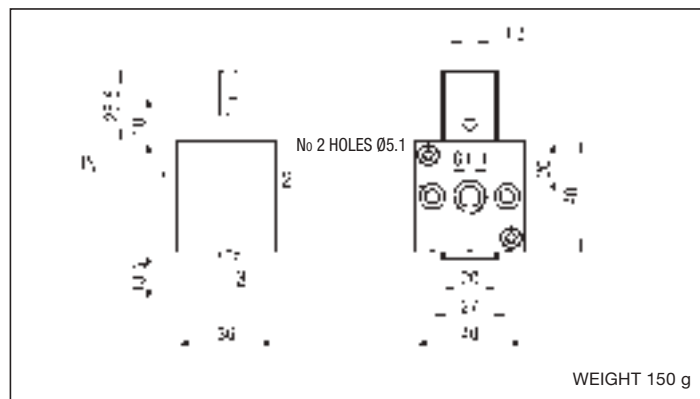

TECHNICAL DATA

Maximum pressure	16 bar
Working temperature	0 ÷ +50 °C (-10° C with dry air)
Fluid	Compressed air
Port size	G 1/4
Pressure gauge port size	G 1/8
Flow rate at 6 bar ΔP=1 bar	260 NI/min
Wall clamping screws	M4x50

DIMENSIONS AND WEIGHT - FR+L

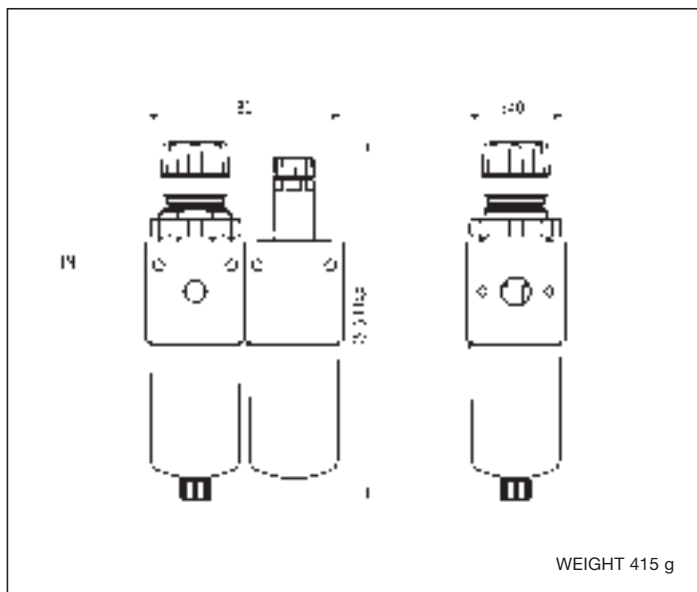

4

ORDER KEY

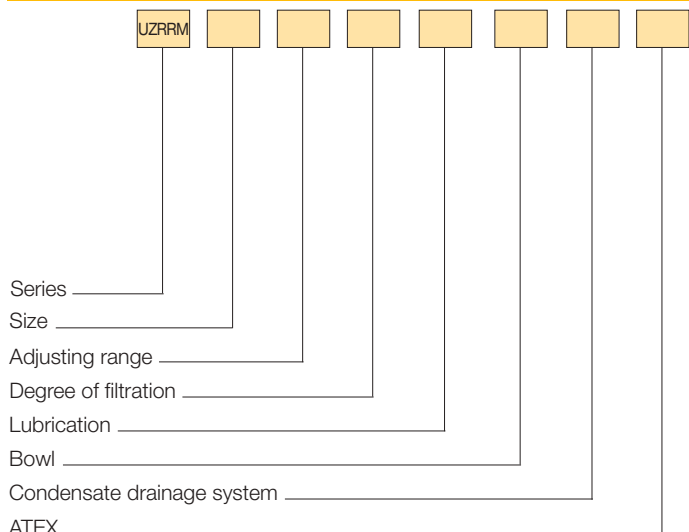

SIZE	
4	G 1/4
DEGREE OF FILTRATION	
/3	0,2 ÷ 2 bar
/7	0,8 ÷ 9 bar
/5	0,4 ÷ 4 bar
/12	1,5 ÷ 12 bar
ADJUSTING RANGE	
F5	5 µm
F40	40 µm
F20	20 µm
LUBRICATION	
L	Oil mist (standard)
LM	Micro-oil mist
BOWL	
	Transparent
/TM	Metallic
/PM	Metallic protection
CONDENSATE DRAINAGE SYSTEM	
	Manual
/SS	Semi-automatic
ATEX	
/EX Consistent with the ATEX directive  II 2GD c T5 T100°C -10°C≤Ta≤50°C*	

P.S.: Filters reducers + lubricators can be supplied without the relieving seal on request; the series becomes **UZRM**...

TECHNICAL DATA

Maximum pressure	16 bar
Working temperature	0 ÷ +50 °C (-10° C with dry air)
Fluid	Compressed air
Port size	G 1/4
Pressure gauge port size	G 1/8
Flow rate at 6 bar ΔP=1 bar	220 NI/min
Wall clamping screws	M4x50

DIMENSIONS AND WEIGHT - F+R+L

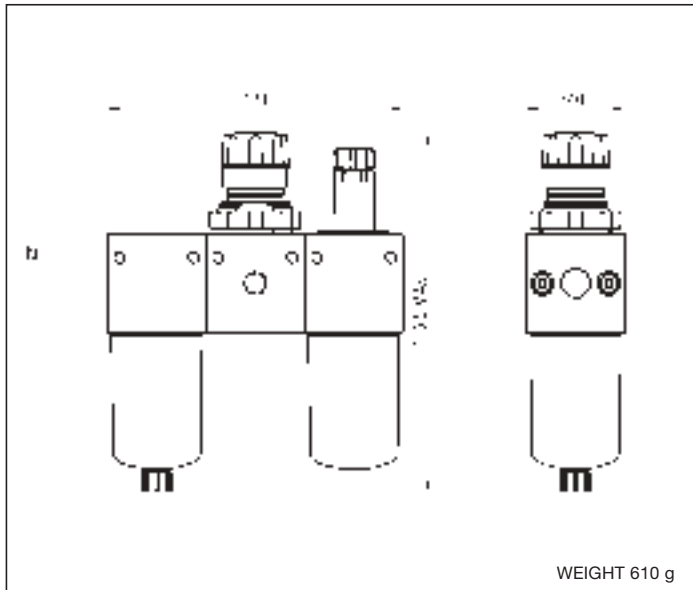

4

ORDER KEY

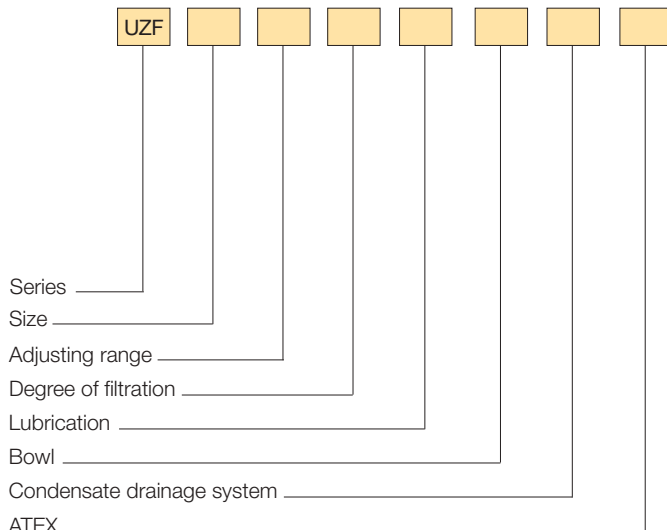

SIZE

4 G 1/4

DEGREE OF FILTRATION

/5 5 µm /20 20 µm
/40 40 µm

ADJUSTING RANGE

RR3 0,2 ÷ 2 bar RR5 0,4 ÷ 4 bar
RR7 0,8 ÷ 9 bar RR12 1,5 ÷ 12 bar

LUBRICATION

L Oil mist (standard) LM Micro-oil mist

BOWL

Transparent /PM Metallic protection
/TM Metallic

CONDENSATE DRAINAGE SYSTEM

Manual /SS Semi-automatic

ATEX

/EX Consistent with the ATEX directive  II 2GD c T5 T100°C -10°C ≤ Ta ≤ 50°C*

P.S.: Filters + reducers + lubricators can be supplied without the relieving seal on request; the adjusting range becomes "R" (rather than "RR")

MOUNTING BRACKET UZRHS

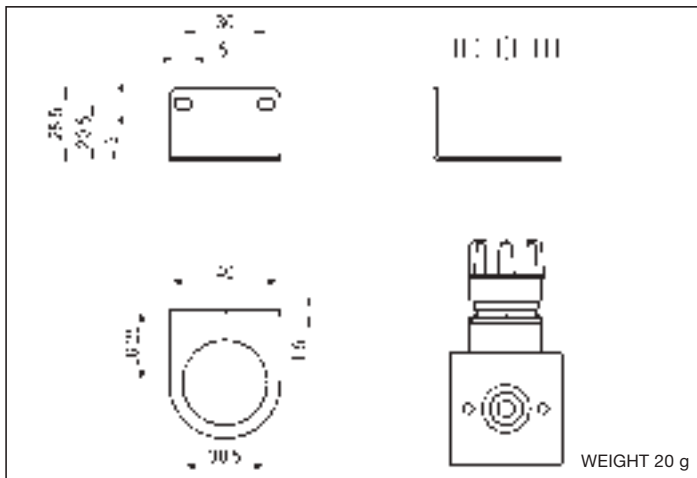

INTERMEDIATE AIR INTAKE UZPR4 (screws included)

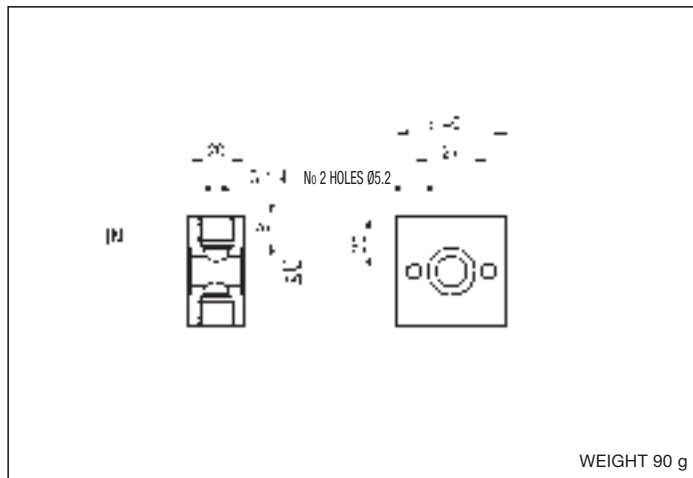

4

ASSEMBLY SCREWS

Assembly screws F+R+L	UZ/SVG
Assembly screws FR+L	UZ/SVG/1
Assembly screws F+L	UZ/SVG/2
Assembly screws FR+L+AP - R+L+AP	UZAP/SVG
Assembly screws FR+AP - R+AP	UZAP/SVG/1
Assembly screws VL+F+R	UZVL/SVG
Assembly screws VL+FR - VL+R	UZVL/SVG/1

WALL CLAMPING SCREWS

Clamping screws F-FR-R-L-AP	UZ/SVG/P
-----------------------------	----------

SHUT-OFF VALVE + FILTER + REDUCER + INTERMEDIATE AIR INTAKE + LUBRICATOR + SOFT-START VALVE

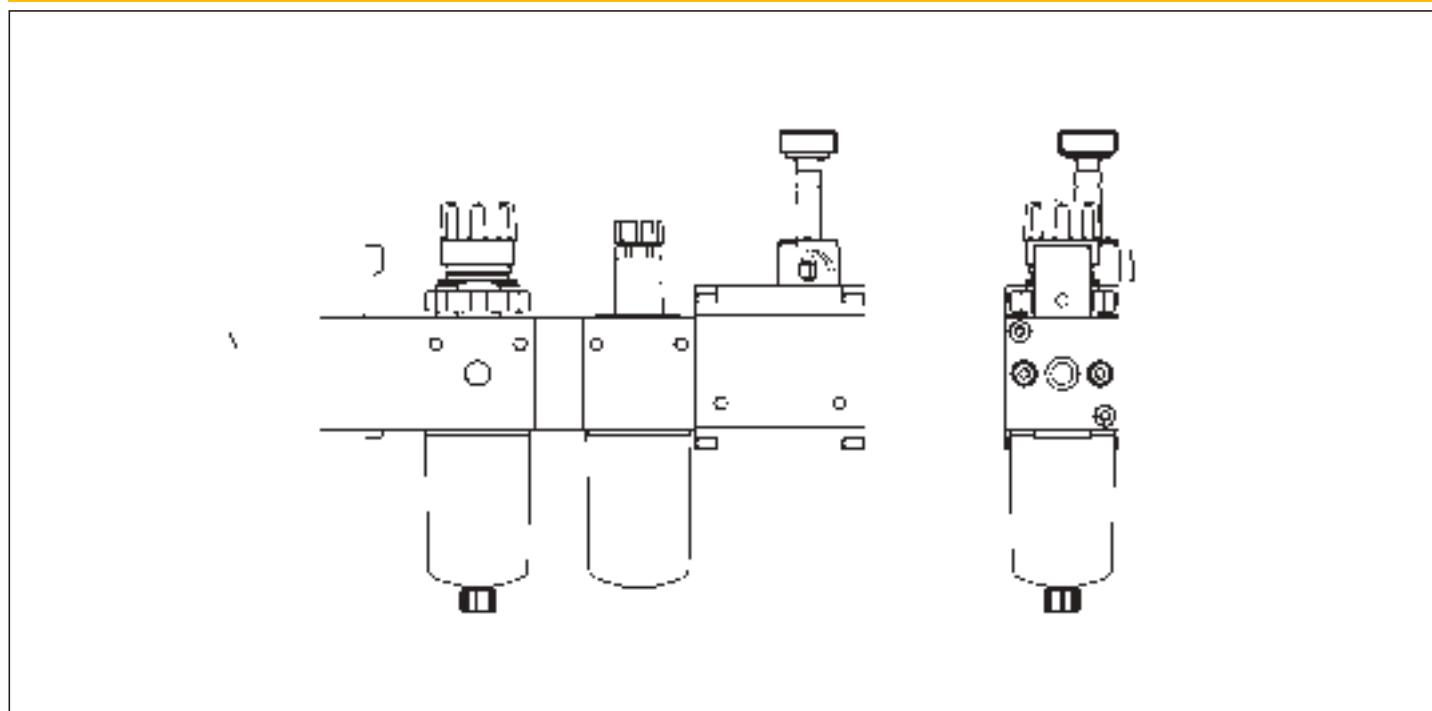

DESCRIPTION

Precision pressure reducers series "RRP" with constant leak (max. 10 l/min) are suitable for application as: process industry, laboratory, checking of balanced mechanisms, elements to tension etc. P.S.: Being high sensitivity components, we suggest the application of a filter with a degree of filtration of 5 µm upstream the precision pressure reducer, while they are not recommended for use in closed circuit (contact our technical office).

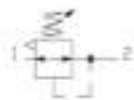

TECHNICAL DATA

Maximum pressure	10 bar
Working temperature	0 ÷ +50°C (-10°C with dry air)
Fluid	Filtered, lubricated and unlubricated compressed air
Port size	G 1/4
Pressure gauge port size	G 1/8
Adjusting range (bar)	0,02 ÷ 0,8; 0,1 ÷ 4; 0,5 ÷ 8
Reproducibility	< 0,3% full-scale
Sensibility	< 0,7% full-scale
Type of mounting	In-line, wall and panel mounting

MATERIALS

Body	Aluminium alloy
Closing plug	Brass, NBR rubber
Spring	Stainless steel
Knob	Acetal resin
Adjusting screw	Brass
Diaphragm	Brass, NBR rubber

DIMENSIONS AND WEIGHT RRP

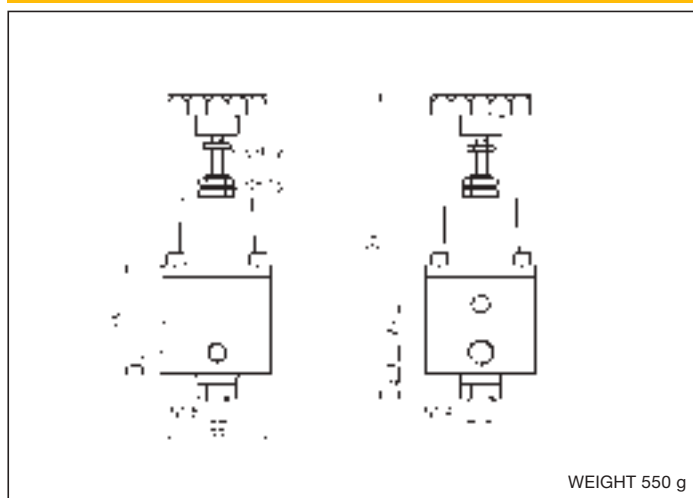

WEIGHT 550 g

4

FLOW CHART - RRP 4/1



FLOW CHART - RRP4/5-RRP4/7

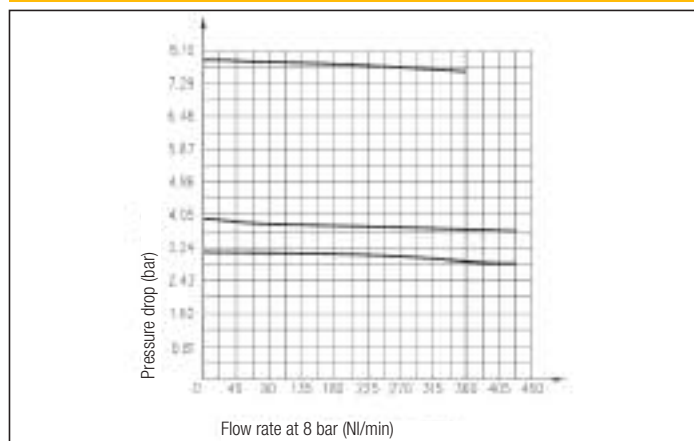

ORDER KEY

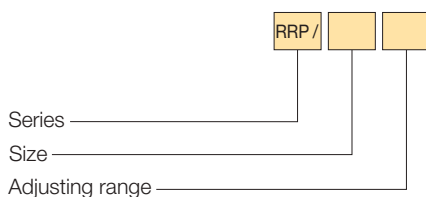

SIZE

4 G 1/4

ADJUSTING RANGE

/1 0,02 ÷ 0,8

/5 0,1 ÷ 4

/7 0,5 ÷ 8

SPARE PARTS

Relieving kit adjustment

RRP/SG/6

DESCRIPTION

Filters series "EZF" are produced with connections G 3/8, G 1/2 and G 1; they are available with various degrees of filtration and with manual, semi-automatic or automatic condensate drainage system (except the size G 3/8). The techno-polymer bowls have a metallic protection as standard for the sizes G 1/2 and G 1, and made of glass stiffened polyamide on request for the size G 3/8. They are in compliance with ATEX directive, 2GD category, upon request.

TECHNICAL DATA

Maximum pressure	16 bar
Working temperature	0 ÷ +50 °C (-10° C with dry air)
Fluid	Compressed air
Port size	G 3/8 - G 1/2 - G 1
Void fraction	G 3/8 - G 1/2: 20 µm standard; 5 µm or 40 µm on request G 1: 40 µm standard
Condensate drainage system	G 3/8: Manual or semi-automatic G 1/2 - G 1: Manual, semi-automatic or automatic
Max. condensate capacity	G 3/8 = 23 cm ³ G 1/2 = 58 cm ³ G 1 = 105 cm ³ (do not exceed the level gauge)
Type of mounting	Modular, in-line and wall-mounting
Wall clamping screws	G 3/8: M4x60 G 1/2: M5x70 G 1: M6x90



MATERIALS

Body	Aluminium alloy
Bowl	G 3/8: Transparent techno-polymer (protection made of glass stiffened polyamide on request) G 1/2 - G 1: Transparent techno-polymer with metallic protection as standard
Filtering element	G 3/8 - G 1/2: sintered polyethylene 5 µm - orange 20 µm - white 40 µm - grey G 1: Sintered porous bronze
Seals	NBR rubber
Baffle	Acetal resin

FLOW CHART - EZF G 3/8

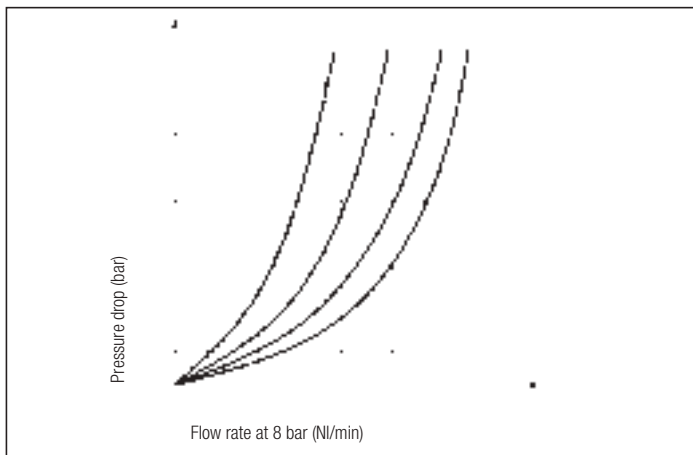

FLOW CHART - EZF G 1/2

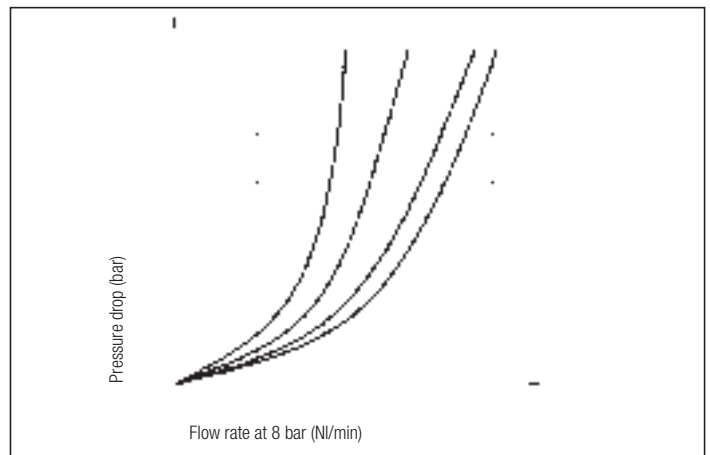

FLOW CHART - EZF G 1

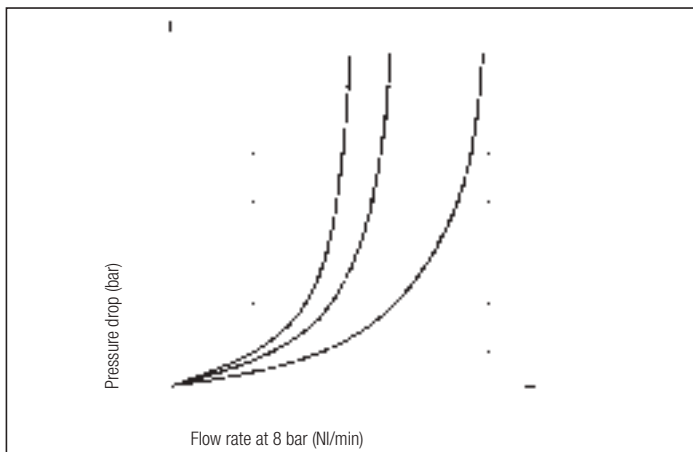

ORDER KEY

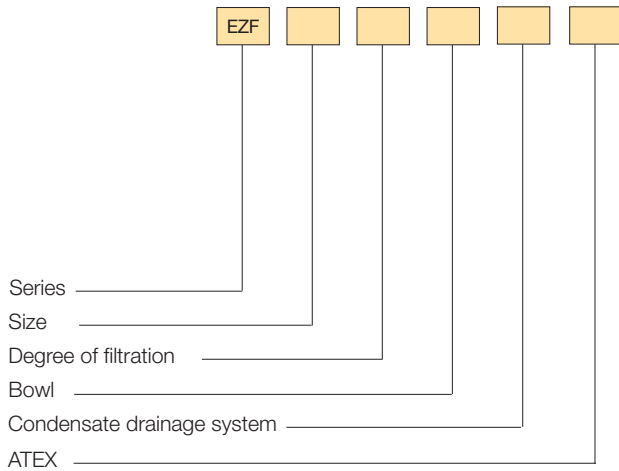

SIZE			
3	G 3/8	2	G 1/2
1	G 1		
DEGREE OF FILTRATION			
/5	5 µm*	/20	20 µm
/40	40 µm		
BOWL			
Trasparent		PM	Protection**
CONDENSATE DRAINAGE SYSTEM			
/SM	Manual	/SS	Semi-automatic
/SA	Automatic***		
ATEX			
/EX Consistent with the ATEX directive II 2GD c T5 T100°C -10°C≤Ta≤50°C			

* Available only for sizes 3 and 2

** Metallic as standard for sizes 2 and 1, made of glass stiffened polyamide on request for size 3

*** Available only for sizes 2 and 1

4

SPARE PARTS

DESCRIPTION	SIZE		
	3	2	1
Bowl protection	EZ3/PM	-	EZ1/PM
Techno-polymer bowl with manual drainage system*	EZT/F3/SM	EZT/F2/PM/SM	EZT/F1/SM
Techno-polymer bowl with semi-automatic drainage system*	EZT/F3/SS	EZT/F2/PM/SS	EZT/F1/SS
Techno-polymer bowl with automatic drainage system*	-	EZT/F2/PM/SA	EZT/F1/SA
Filter cartridge 5 µm	EZ3/5	EZ2/5	-
Filter cartridge 20 µm	EZ3/20	EZ2/20	EZ1/20
Filter cartridge 40 µm	EZ3/40	EZ2/40	EZ1/40

* The bowls size 2 are supplied with metallic protection as standard

DIMENSIONS AND WEIGHTS - EZF

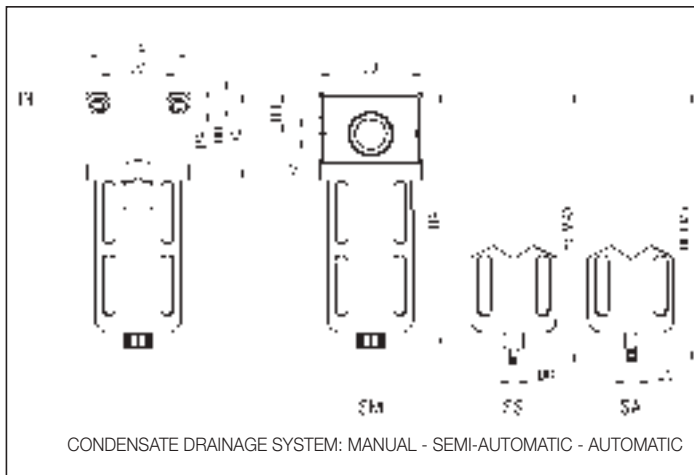

SIZE	DA	DB	DC	FA	HA	HB	HC	HD	HE	HF	LA	LB	LC	WEIGHT (g)
3	4,5	G 1/8	-	G 3/8	142	21	52	6	146	-	55	50	40	390
2	5,5	Ø 4,3	Ø 6,5	G 1/2	159	26	55	8,5	170	168	65	65	49	415
1	6,6	G 1/8	Ø 6,5	G 1	218	31	76	9	222	213	85	82	60	1815

DESCRIPTION

Pressure reducers series "EZRR" are produced with connections G 3/8, G 1/2 and G 1; they are available with different scales of regulation and can be supplied without the relieving seal on request. They are in compliance with ATEX directive, 2GD category, upon request.

TECHNICAL DATA

Maximum pressure	16 bar
Working temperature	0 ÷ +50 °C (-10° C with dry air)
Fluid	Filtered, lubricated and unlubricated compressed air
Port size	G 3/8 - G 1/2 - G 1
Pressure gauge port size	G 1/8
Adjusting range (bar)	0,2 ÷ 2 - 0,4 ÷ 4 - 0,8 ÷ 8
Type of mounting	Modular, in-line, wall and panel mounting
Wall clamping screws	G 3/8: M4x60 G 1/2: M5x70 G 1: M6x90



MATERIALS

Body	Aluminium alloy
Closing plug	Brass, NBR rubber
Spring	Stainless steel
Knob	Acetal resin
Adjusting screw	Brass
Diaphragm	Brass, friction

FLOW CHART - EZRR G 3/8

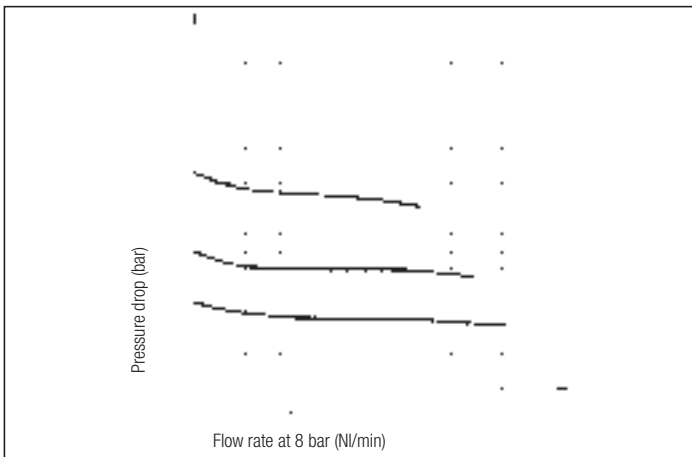

FLOW CHART - EZRR G 1/2

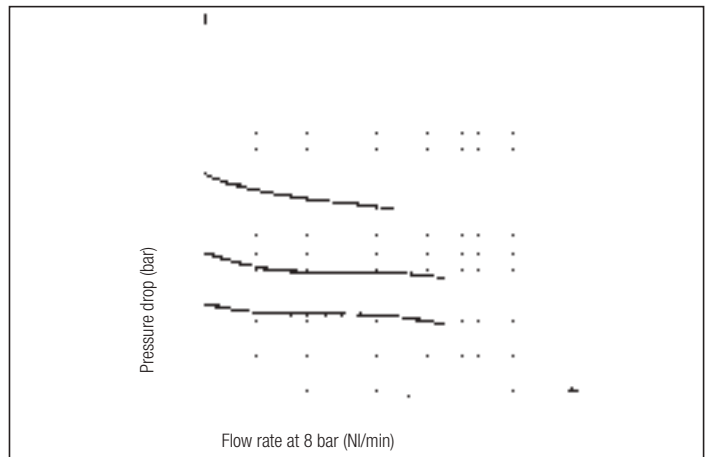

FLOW CHART - EZRR G 1

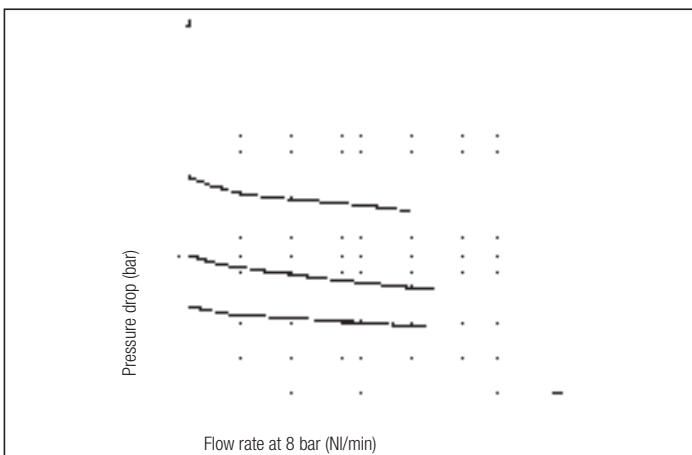

ORDER KEY

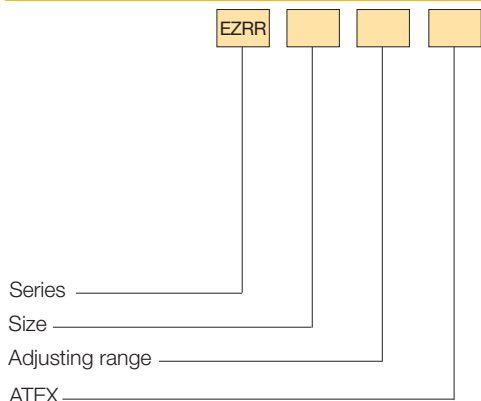

SIZE			
3	G 3/8	2	G 1/2
1	G 1		
ADJUSTING RANGE			
/3	0,2 ÷ 2 bar	/5	0,4 ÷ 4 bar
/7	0,8 ÷ 8 bar		
ATEX			
/EX Consistent with the ATEX directive  II 2GD c T5 T100°C -10°C≤T _a ≤50°C			

P.S.: Reducers can be supplied without the relieving seal on request; the series becomes **EZR...**

DIMENSIONS AND WEIGHTS - EZRR

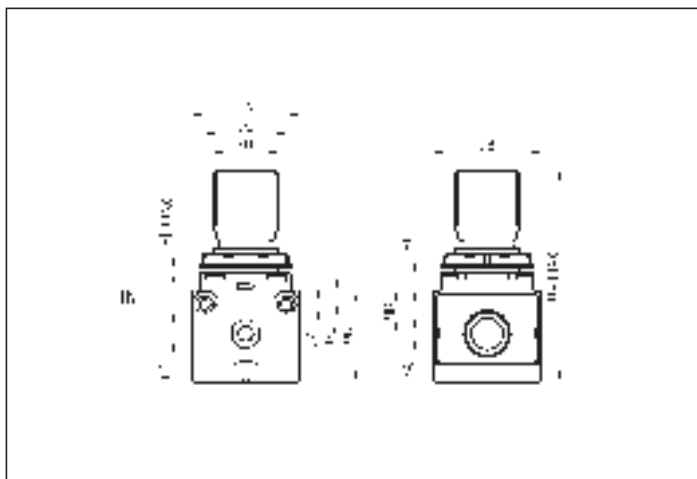

SPARE PARTS

Relieving kit adjustment size 3	EZRR3/SG/6
Relieving kit adjustment size 2	EZRR2/SG/6
Relieving kit adjustment size 1	EZRR1/SG/6

SIZE	DA	FA	FB	FC	HA	HB	HC	HD	HE	HF	LA	LB	LC	WEIGHT (g)
3	4,5	G 3/8	M30x1,5	G 1/8	99	21	48	6	4	6	55	50	40	450
2	5,5	G 1/2	M40x1,5	G 1/8	127	26	55	8,5	7	10,5	65	65	49	465
1	6,6	G 1	-	G 1/8	194,5	31	76	9	-	14	85	82	60	2385

DESCRIPTION

Filters reducers series "EZRR/F", produced with connections G 3/8, G 1/2 and G 1, combine the characteristics of the filters and of the pressure reducers series "EZ", thus optimizing the overall dimensions. They are in compliance with ATEX directive, 2GD category, upon request.

TECHNICAL DATA

Maximum pressure	16 bar
Working temperature	0 ÷ +50 °C (-10 °C with dry air)
Fluid	Compressed air
Port size	G 3/8 - G 1/2 - G 1
Pressure gauge port size	G 1/8
Void fraction	G 3/8 - G 1/2: 20 µm standard, 5 µm and 40 µm on request G 1: 40 µm standard
Condensate drainage system	G 3/8: manual or semi-automatic G 1/2 - G 1: manual, semi-automatic or automatic
Max. condensate capacity	G 3/8 = 23 cm ³ G 1/2 = 58 cm ³ G 1 = 105 cm ³ (do not exceed the level gauge)
Adjusting range (bar)	0,2 ÷ 2 - 0,4 ÷ 4 - 0,8 ÷ 8
Type of mounting	Modular, in-line, wall and panel mounting
Wall clamping screws	G 3/8: M4x60 G 1/2: M5x70 G 1: M6x90



MATERIALS

Body	Aluminium alloy
Bowl	G 3/8: Transparent techno-polymer (protection made of glass stiffened polyamide on request) G 1/2 - G 1: Transparent techno-polymer with metallic protection as standard
Filtering element	G 3/8 - G 1/2: sintered polyethylene 5 µm - orange 20 µm - white 40 µm - grey G 1: sintered porous bronze
Seals	NBR rubber
Baffle	Acetal resin
Closing plug	Brass, NBR rubber
Spring	Stainless steel
Knob	Acetal resin
Adjusting screw	Brass
Diaphragm	Brass, friction

FLOW CHART - EZRR /F G 3/8

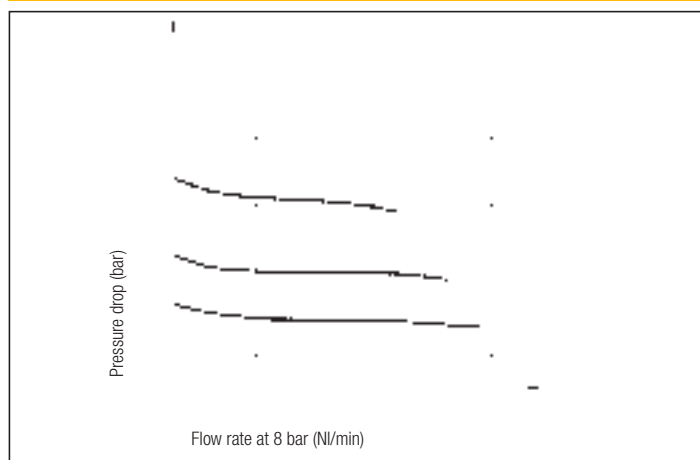

FLOW CHART - EZRR /F G 1/2

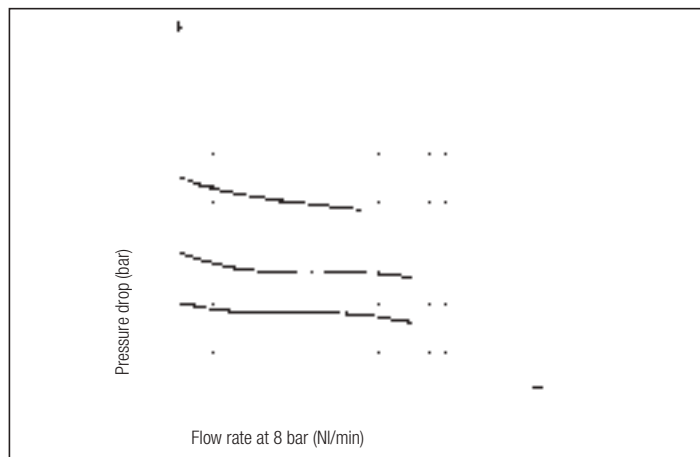

FLOW CHART - EZRR /F G 1

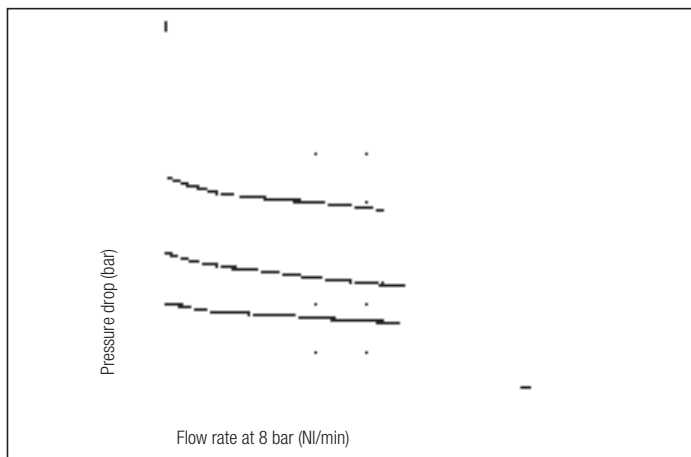

ORDER KEY

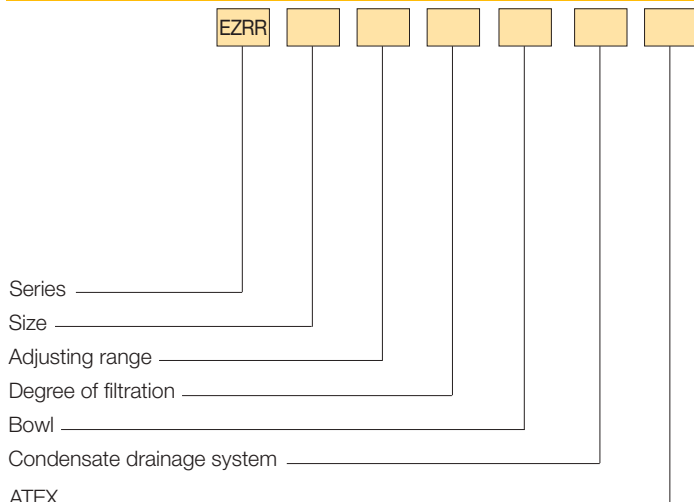

SIZE			
3	G 3/8	2	G 1/2
1	G 1		
ADJUSTING RANGE			
/3	0,2 ÷ 2 bar	/5	0,4 ÷ 4 bar
/7	0,8 ÷ 8 bar		
DEGREE OF FILTRATION			
F5	5 µm*	F20	20 µm
F40	40 µm		
BOWL			
	Trasparent	PM	Protection**
CONDENSATE DRAINAGE SYSTEM			
/SM	Manual	/SS	Semi-automatic
/SA	Automatic***		
ATEX			
/EX Consistent with the ATEX directive  II 2GD c T5 T100°C -10°C≤Tas≤50°C			

* Available only for sizes 3 and 2
 ** Metallic as standard for sizes 2 and 1, made of glass stiffened polyamide on request for size 3
 *** Available only for sizes 2 and 1
 P.S.: Filters reducers can be supplied without the relieving seal on request; the series becomes **EZR**...

SPARE PARTS

See series **EZF** (on page 4.13) and **EZRR** (on page 4.15)

DIMENSIONS AND WEIGHTS - EZRR /F

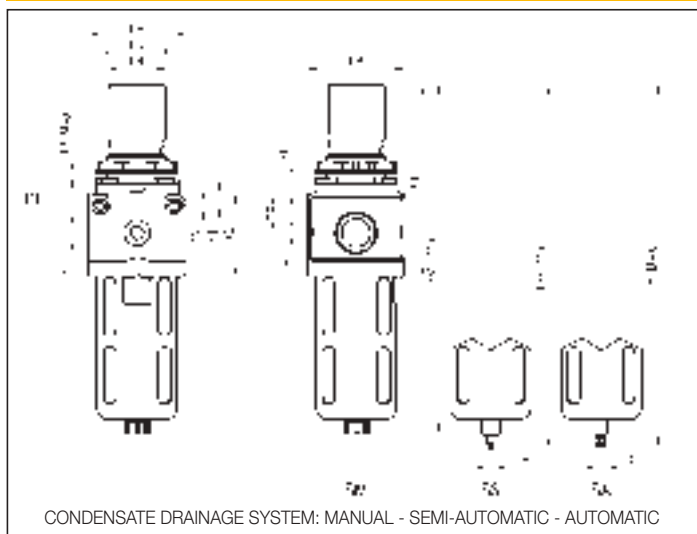

SIZE	DA	DB	DC	FA	FB	FC	HA	HB	HC	HD
3	4,5	G 1/8	-	G 3/8	M30x1,5	G 1/8	193	21	52	6
2	5,5	Ø 4,3	Ø 6,5	G 1/2	M40x1,5	G 1/8	231	26	55	8,5
1	6,6	G 1/8	Ø 6,5	G 1	-	G 1/8	337	31	76	9

SIZE	HE	HF	HG	HH	HI	LA	LB	LC	WEIGHT (g)
3	4	6	99	197	-	55	50	40	550
2	7	10,5	127	242	240	65	65	42	610
1	-	14	194,5	341	332	85	82	60	2790

DESCRIPTION

Lubricators series "EZL" are produced with connections G 3/8, G 1/2 and G 1; the techno-polymer bowls have a metallic protection as standard for the sizes G 1/2 and G 1, and made of glass stiffened polyamide on request for the size G 3/8.

For a correct lubrication it is advisable to set the drip rate in order to have a drop WAIRSOL class ISO15 every 300 - 500 NI/min. (oil mist lubrication). They are in compliance with ATEX directive, 2GD category, upon request.

TECHNICAL DATA

Maximum pressure	16 bar
Working temperature	0 ÷ +50 °C (-10 °C with dry air)
Fluid	Filtered compressed air
Port size	G 3/8 - G 1/2 - G 1
Bowl capacity	G 3/8 = 32 cm ³ G 1/2 = 76 cm ³ G 1 = 160 cm ³ (do not exceed the level gauge)
Type of mounting	Modular, in-line and wall-mounting
Wall clamping screws	G 3/8: M4x60 G 1/2: M5x70 G 1: M6x90
Minimum striking flow rate	G 3/8 = 25 NI/min G 1/2 = 25 NI/min G 1 = 50 NI/min



MATERIALS

Body	Aluminium alloy
Bowl	G 3/8: Transparent techno-polymer (protection made of glass stiffened polyamide on request) G 1/2 - G 1: Transparent techno-polymer with metallic protection as standard
Seals	NBR rubber
Conduits	Acetal resin

FLOW CHART - EZL G 3/8

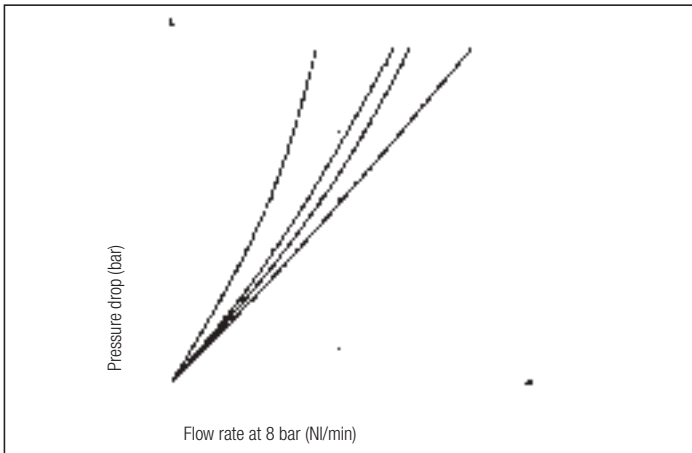

FLOW CHART - EZL G 1/2

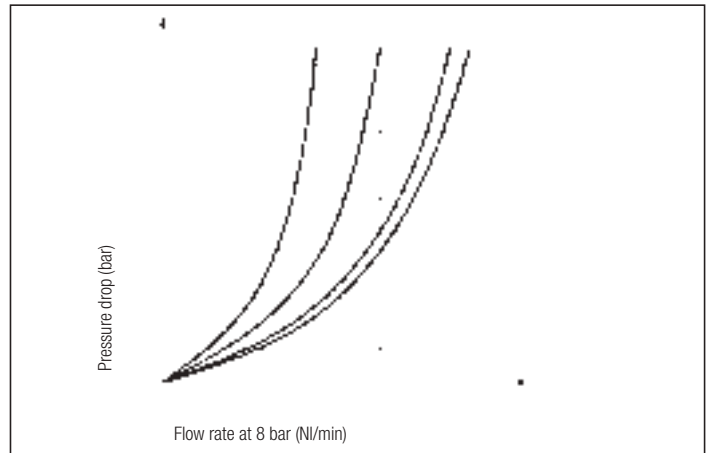

FLOW CHART - EZL G 1

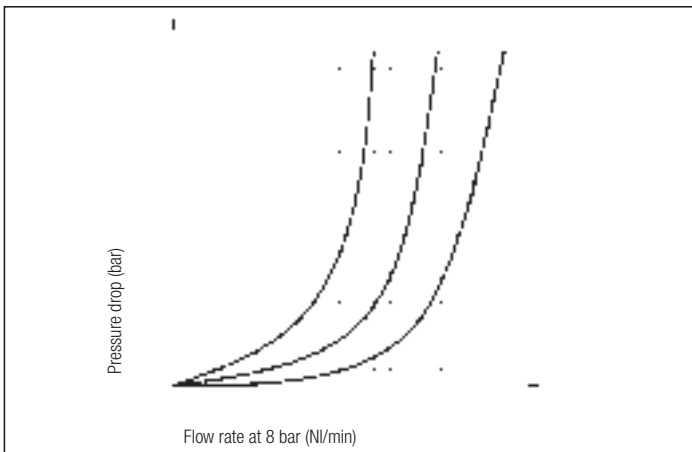

ORDER KEY

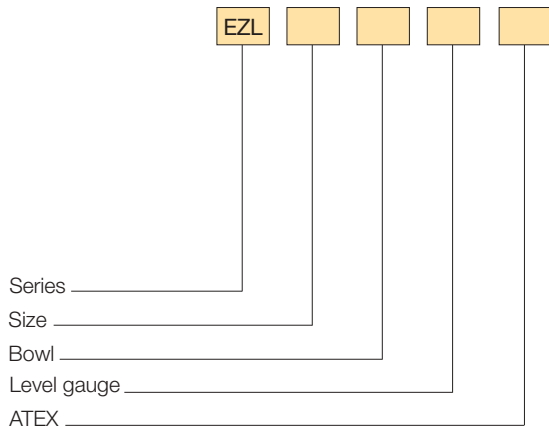

SIZE			
3	G 3/8	2	G 1/2
1	G 1		
BOWL			
Trasparent		PM	Protection*
LEVEL GAUGE			
Open electric			
/CA Open electric contact when oil is present with 2 wires cable 0,5 m length			
/CC Closed electric contact when oil is present with 2 wires cable 0,5 m length			
ATEX			
/EX Consistent with the ATEX directive II 2GD c T5 T100°C -10°C ≤ Ta ≤ 50°C			

* Metallic as standard for sizes 2 and 1, made of glass stiffened polyamide on request for size 3
P.S.: Level gauge, in both the open and closed electric contact, is fed with a voltage range from 6 V to 50 V

4

DIMENSIONS AND WEIGHTS - EZL

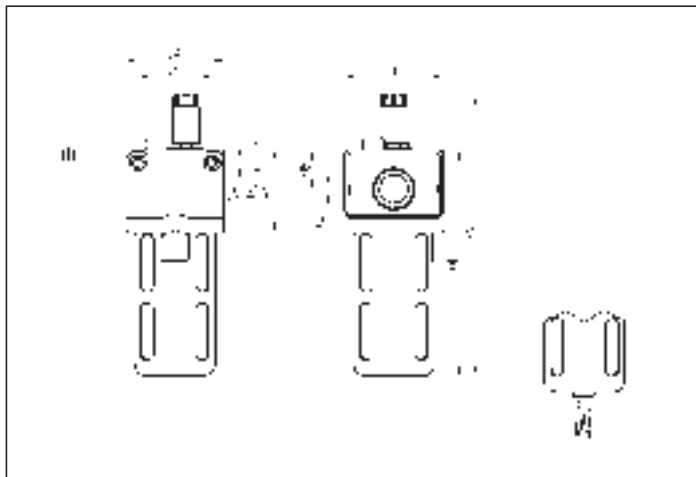

SPARE PARTS

Lubricator bowl size 3	EZT/L3
Lubricator bowl size 2*	EZT/L2/PM
Lubricator bowl size 1	EZT/L1
Lubricator bowl for level gauge size 3	EZT/L3/SLC
Lubricator bowl for level gauge size 2*	EZT/L2/PM/SLC
Lubricator bowl for level gauge size 1	EZT/L1/SLC
Protection made of glass stiffened nylon size 3	EZ3/PM
Metallic protection size 1	EZ1/PM
Lubricator clear cover size 3	EZL3/C
Lubricator clear cover size 2	EZL2/C
Lubricator clear cover size 1	EZL1/C
Level gauge with open electric contact size 3	EZT/L3/SLA
Level gauge with open electric contact size 2*	EZT/L2/PM/SLA
Level gauge with open electric contact size 1	EZT/L1/SLA

* The bowls size 2 are supplied with metallic protection as standard

SIZE	DA	FA	HA	HB	HC	HD	HE	LA	LB	LC	WEIGHT (g)
3	4,5	G 3/8	157,5	21	52	6	121	55	50	40	370
2	5,5	G 1/2	186,7	26	55	8,5	149,7	65	65	49	400
1	6,6	G 1	243,5	31	76	9	201	85	82	60	1780

DESCRIPTION

Soft - start valves series "EZAP" are produced with connections G 3/8, G 1/2 and G 1 in the pneumatic and solenoid actuated versions. The working of the soft-start valves consists in feeding gradually air into the circuit with adjustable flow. When the pressure in the circuit reaches the 50 ÷ 60% of the upstream set pressure, the valve switches to full capacity, supplying the circuit with the maximum flow rate. They are in compliance with ATEX directive, 2GD category, upon request.

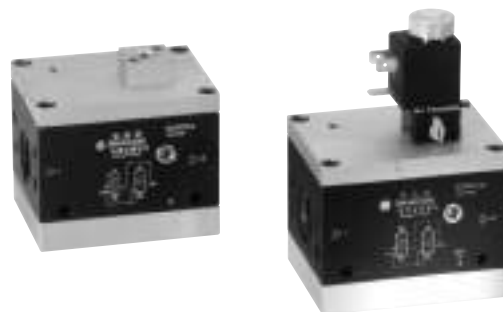

TECHNICAL DATA

Maximum pressure	10 bar
Working temperature	0 ÷ +50 °C (-10 °C with dry air)
Fluid	Filtered, unlubricated or continuous lubricated compressed air
Port size	G 3/8 - G 1/2 - G 1
Flow rate at 6 bar ΔP=1 bar	G 3/8 = 1000 NI/min G 1/2 = 1650 NI/min G 1 = 4000 NI/min
Max. flow rate of the adjusting screw of the filling time	G 3/8 = 400 NI/min G 1/2 = 500 NI/min G 1 = 500 NI/min
Type of mounting	Modular, in-line and wall-mounting
Wall clamping screws	G 3/8: M4x60 G 1/2: M5x70 G 1: M6x90
Piloting solenoid valve	C/USCSVP - see chapter Direct acting solenoid valves on page 2.14
Coils	USB - see chapter Coils on page 2.17 USBG - see chapter Coils on page 2.17 USBG2 - see chapter Coils on page 2.17
Electric connector	USR 102/N9 - see chapter Connectors on page 2.18 ULR1B - see chapter Connectors on page 2.18

MATERIALS

Body	Aluminium alloy
Springs	Stainless steel
Pistons	Aluminium alloy
Seals	NBR rubber

ORDER KEY

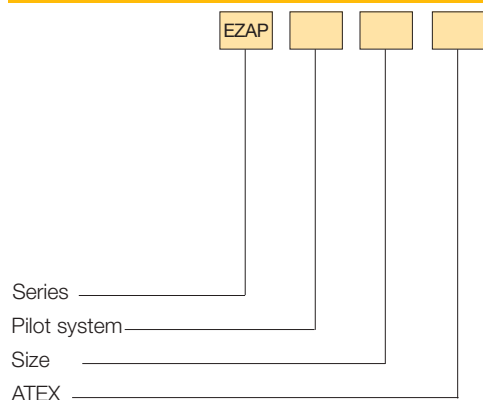

PILOT SYSTEM

/R Pneumatic /U Solenoid

SIZE

3 G 3/8 2 G 1/2
1 G 1

ATEX

/EX Consistent with the ATEX directive II 2GD c T5 T100°C -10°C ≤ Ta ≤ 50°C

DIMENSIONS AND WEIGHTS - EZAP /R

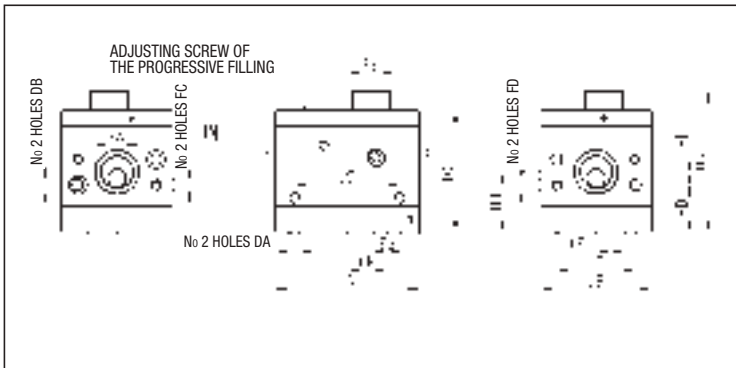

SIZE	DA	DB	FA	FB	FC	FD	FE	HA	HB	HC
3	4,5	5,1	G 3/8	G 1/8	-	M6	G 1/8	68	28,8	56,5
2	5,5	6,5	G 1/2	G 3/8	M6	M6	G 1/8	82,5	35	71

SIZE	HD	HE	LA	LB	LC	LD	LE	LF	WEIGHT (g)
3	28,8	-	70	50	51,5	35	20	12	505
2	27,5	15	85	65	62	46	23,5	17	985

DIMENSIONS AND WEIGHTS - EZAP /U

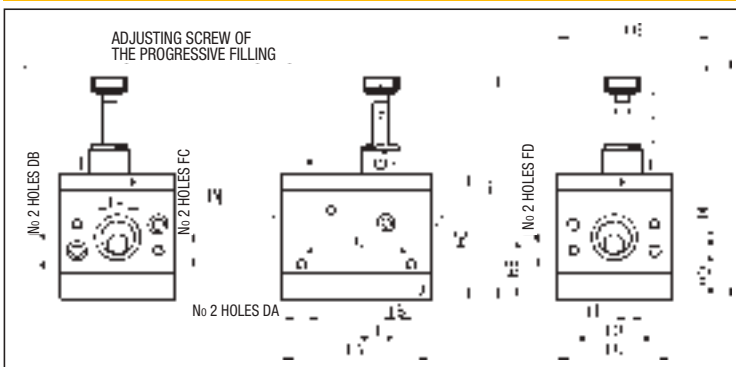

SIZE	DA	DB	FA	FB	FC	FD	HA	HB	HC	HD
3	4,5	5,1	G 3/8	G 1/8	-	M6	122,5	28,8	56,5	28,8
2	5,5	6,5	G 1/2	G 3/8	M6	M6	137	35	71	27,5

SIZE	HE	HF	LA	LB	LC	LD	LE	LF	LG	WEIGHT (g)
3	-	115,5	70	50	51,5	35	20	12	79,5	540
2	15	126	85	65	62	46	23,5	17	87	1020

DIMENSIONS AND WEIGHT - EZAP/R1

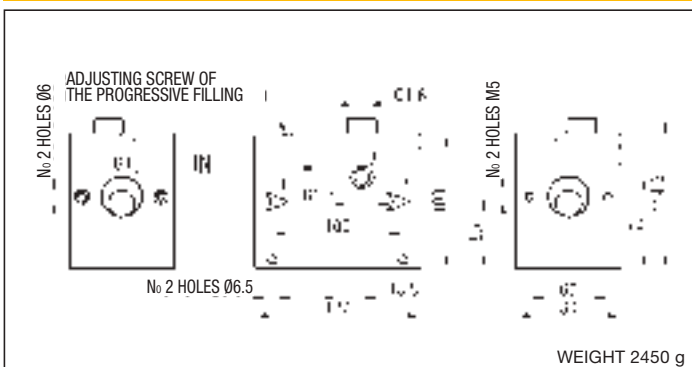

DIMENSIONS AND WEIGHT - EZAP/U1

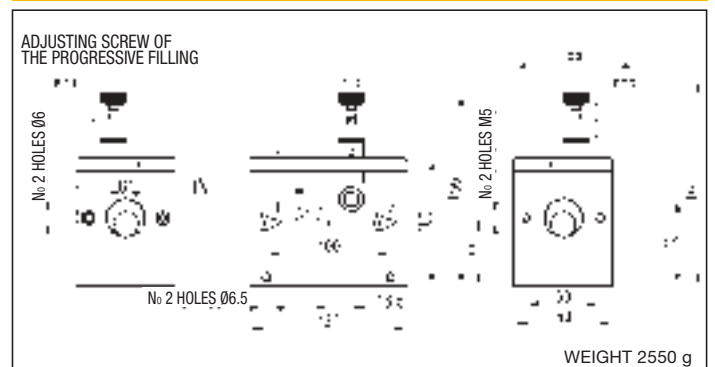

DESCRIPTION

Shut - off valves series "EZVL" are produced with connections G 3/8, G 1/2 and G 1 and they are fit to be locked in the exhaust position by means of a standard padlock. They are in compliance with ATEX directive, 2GD category, upon request.

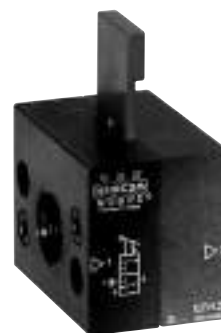

TECHNICAL DATA

Maximum pressure	16 bar
Working temperature	0 ÷ +50 °C (-10 °C with dry air)
Fluid	Filtered, lubricated and unlubricated compressed air
Flow rate at 6 bar ΔP=1 bar	G 3/8 = 2400 NI/min G 1/2 = 3150 NI/min G 1 = 4250 NI/min
Port size	G 3/8 - G 1/2 - G 1
Type of mounting	Modular and in-line

DIMENSIONS AND WEIGHTS - EZVL

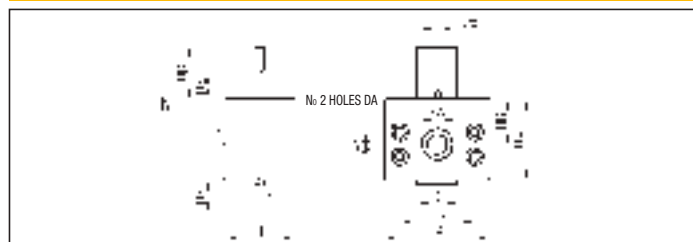

MATERIALS

Body	Anodized aluminium alloy
Seals	NBR rubber
Slider	Anodized aluminium alloy

TYPE	DA	DB	FA	HA	HB	HC	HD	HE	HF	LA	LB	LC	LD	WEIGHT (g)
EZVL/3	5,5	4,2	G 3/8	50	25	-	36	15	21	50	39	35	25	260
EZVL/2	6,5	4,2	G 1/2	50	28	15	32	15	20	65	43	46	25	370
EZVL/1	6,1	4,2	G 1	60	30	-	34	15	22	80	60	60	25	700

Air treatment: filter reducer + lubricator G 3/8 - G 1/2 - G 1

series EZ

TECHNICAL DATA

Maximum pressure	16 bar
Working temperature	0 ÷ +50 °C (-10 °C with dry air)
Fluid	Compressed air
Port size	G 3/8 - G 1/2 - G 1
Pressure gauge port size	G 1/8
Flow rate at 6 bar ΔP=1 bar	G 3/8 = 680 NI/min G 1/2 = 1200 NI/min G 1 = 2300 NI/min
Wall clamping screws	G 3/8: M4x60 G 1/2: M5x70 G 1: M6x90

DIMENSIONS AND WEIGHTS - FR+L

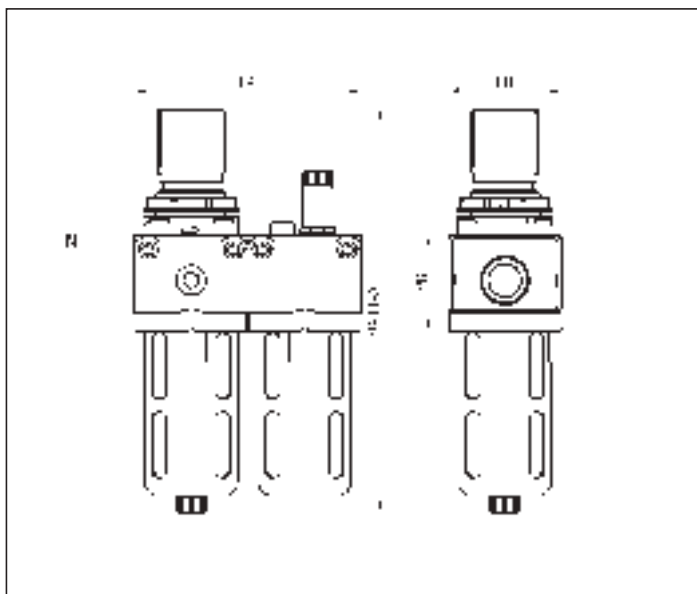

SIZE	HA	HB	LA	LB	WEIGHT (g)
3	193	52	107	50	940
2	231	55	130	65	1065
1	337	76	167	82	4695

ORDER KEY

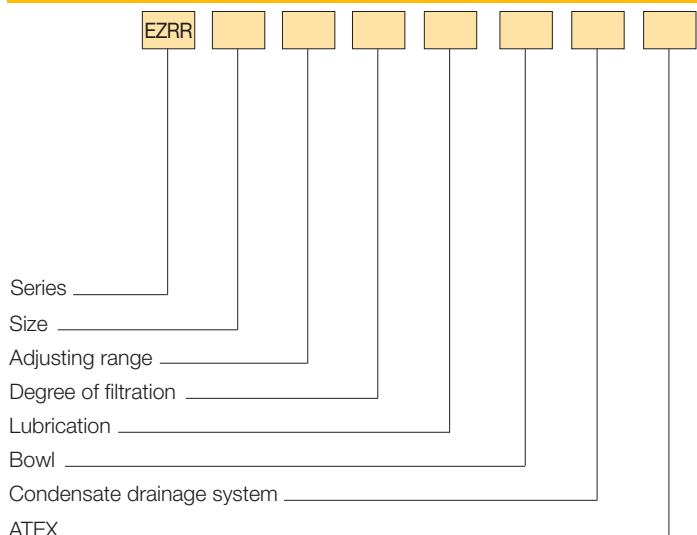

SIZE	
3 G 3/8	2 G 1/2
1 G 1	
ADJUSTING RANGE	
/3 0,2 ÷ 2 bar	/5 0,4 ÷ 4 bar
/7 0,8 ÷ 8 bar	
DEGREE OF FILTRATION	
F5 5 µm*	F20 20 µm
F40 40 µm	
LUBRICATION	
L Oil mist (standard)	LCA Oil mist, N.O. electric contact
LCC Oil mist, N.C. electric contact	
BOWL	
Trasparent	/PM Protection**
CONDENSATE DRAINAGE SYSTEM	
/SM Manual	/SS Semi-automatic
/SA Automatic***	
ATEX	
/EX Consistent with the ATEX directive  II 2GD c T5 T100°C -10°C ≤ Ta ≤ 50°C	

* Available only for sizes 3 and 2
 ** Metallic as standard for sizes 2 and 1, made of glass stiffened polyamide on request for size 3
 *** Available only for sizes 2 and 1
 P.S.: Filters reducers + lubricators can be supplied without the relieving seal on request; the series becomes **EZR**...

4

series EZ

**Air treatment:
filter + reducer + lubricator
G 3/8 - G 1/2 - G 1**

TECHNICAL DATA

Maximum pressure	16 bar
Working temperature	0 ÷ +50 °C (-10 °C with dry air)
Fluid	Compressed air
Port size	G 3/8 - G 1/2 - G 1
Pressure gauge port size	G 1/8
Flow rate at 6 bar ΔP=1 bar	G 3/8 = 630 NI/min G 1/2 = 1100 NI/min G 1 = 2100 NI/min
Wall clamping screws	G 3/8: M4x60 G 1/2: M5x70 G 1: M6x90

DIMENSIONS AND WEIGHTS - F+R+L

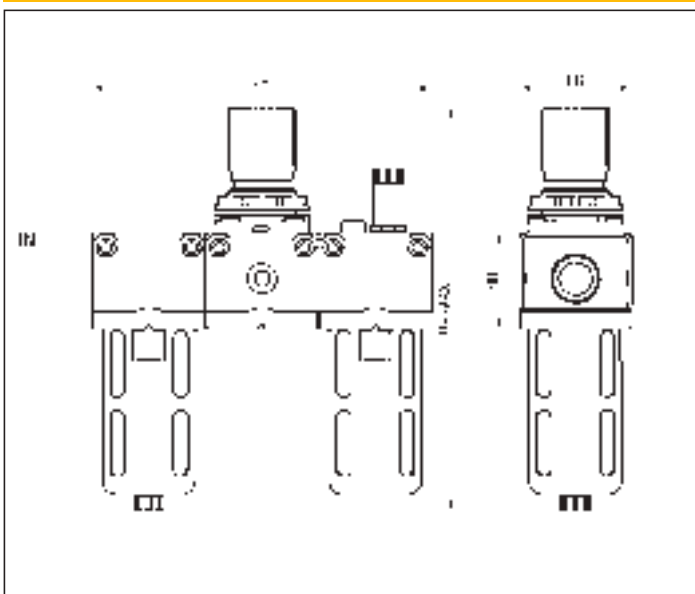

SIZE	HA	HB	LA	LB	WEIGHT (g)
3	193	52	159	50	1260
2	231	55	195	65	1345
1	337	76	249	82	6080

ORDER KEY

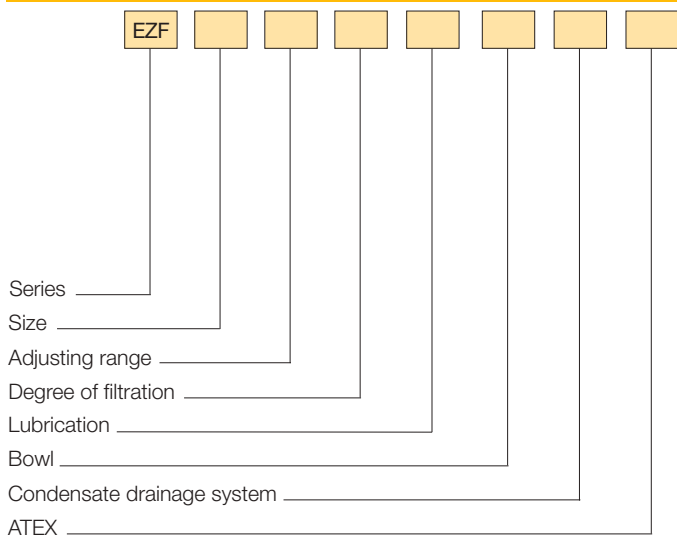

SIZE	
3 G 3/8	2 G 1/2
1 G 1	
ADJUSTING RANGE	
RR3 0,2 ÷ 2 bar	RR5 0,4 ÷ 4 bar
RR7 0,8 ÷ 8 bar	
DEGREE OF FILTRATION	
/5 5 µm*	/20 20 µm
/40 40 µm	
LUBRICATION	
L Oil mist (standard)	LCA Oil mist, N.O. electric contact
LCC Oil mist, N.C. electric contact	
BOWL	
Transparent	/PM Protection**
CONDENSATE DRAINAGE SYSTEM	
/SM Manual	/SS Semi-automatic
/SA Automatic***	
ATEX	
/EX Consistent with the ATEX directive II 2GD c T5 T100°C -10°C ≤ Ta ≤ 50°C	

* Available only for sizes 3 and 2

** Metallic as standard for sizes 2 and 1, made of glass stiffened polyamide on request for size 3

*** Available only for sizes 2 and 1

P.S.: Filters + reducers + lubricators can be supplied without the relieving seal on request; the adjusting range becomes "R" (rather than "RR")

DESCRIPTION

Proportional valves allow to adjust the output pressure by means of an electric signal. Depending on the set pressure, there's an output electrical signal, called "feedback signal". These valves have a display that, besides indicating the regulated pressure, facilitates the configuration thanks to the user panel at the valveside. These valves are available in G1/8", G1/4" and G1/2" sizes.

TECHNICAL DATA

Operating pressure	Maximum regulating pressure + 1 bar	
Maximum pressure	10 bar for the models with adjusting range: 0 ÷ 5 and 0 ÷ 9 bar 2 bar for the models with adjusting range: 0 ÷ 1 bar	
Working temperature	0 ÷ 50 °C	
Fluid	Filtered, unlubricated or continuous lubricated compressed air	
Port size	G1/8 - G1/4 - G1/2	
Pressure gauge port size	G1/8	
Pressure with Pa=6 bar and Δp=1	G1/8: 290 NI/min	G1/4: 1440 NI/min
	G1/2: 4800 NI/min	
Supply voltage	24 VDC	
Apparent power	< 6W	
Voltage tolerance	± 10%	
Protection class	IP65	
Electric connector	M12A 4 PIN	
Sensitivity	≤ ± 0,5% F.S.	
Linearity	≤ ± 1,0% F.S.	
Ripeatability	≤ ± 0,5 F.S.	
Hysteresis	≤ 0,5% F.S.	



MATERIALS

End cap	Techno-polymer
Body	Aluminium
Spring	Stainless steel
Seals	NBR

ORDER KEY

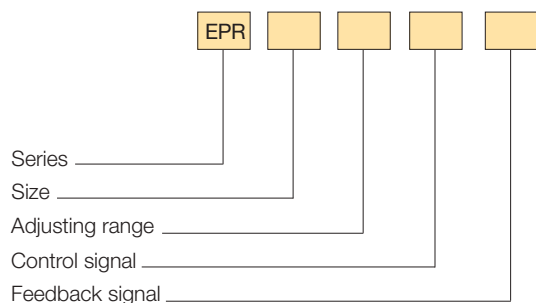

SIZE

8	G 1/8	4	G 1/4
2	G 1/2		

ADJUSTING RANGE

/1	0 ÷ 1 bar	/5	0 ÷ 5 bar
/9	0 ÷ 9 bar		

CONTROL SIGNAL

T	Voltage: 0 ÷ 5 VDC / 0 ÷ 10 VDC (can be set up by the user)
A	Current: 0 ÷ 20 mA DC / 4 ÷ 20 mA DC (can be set up by the user)
4S	Four control signals ON/OFF

FEEDBACK SIGNAL

F15	1 ÷ 5 VDC	F420	4 ÷ 20 mA DC
FP	24VDC PNP	FN	24VDC NPN

ORDER EXAMPLES

Proportional valve size G1/2, adjusting range from 0 to 5 bar, control signal in voltage, feedback signal in voltage (from 1 to 5 VDC): **EPR2/5TF15**.

Proportional valve size G1/4, adjusting range from 0 to 1 bar, control signal in current, feedback signal (PNP24 VDC): **EPR4/1AFP**.

CONNECTOR TO USER INTERFACE

CONNECTOR M12A 4 PIN

(SET) Enter / set up value

Scroll down / to decrease value ▼

Scroll up / to increase value ▲

LED status indicator

Display

N° PIN	Corresponding cable color	Disposition with control signal in VDC or mA	Disposition with four control signals
1	Red/Brown	+24 VDC	+24 VDC
2	White	Control signal	Switch 1
3	Blue	GND	GND
4	Black	Feedback signal	Switch 2

DIMENSIONS AND WEIGHT SIZE G1/8

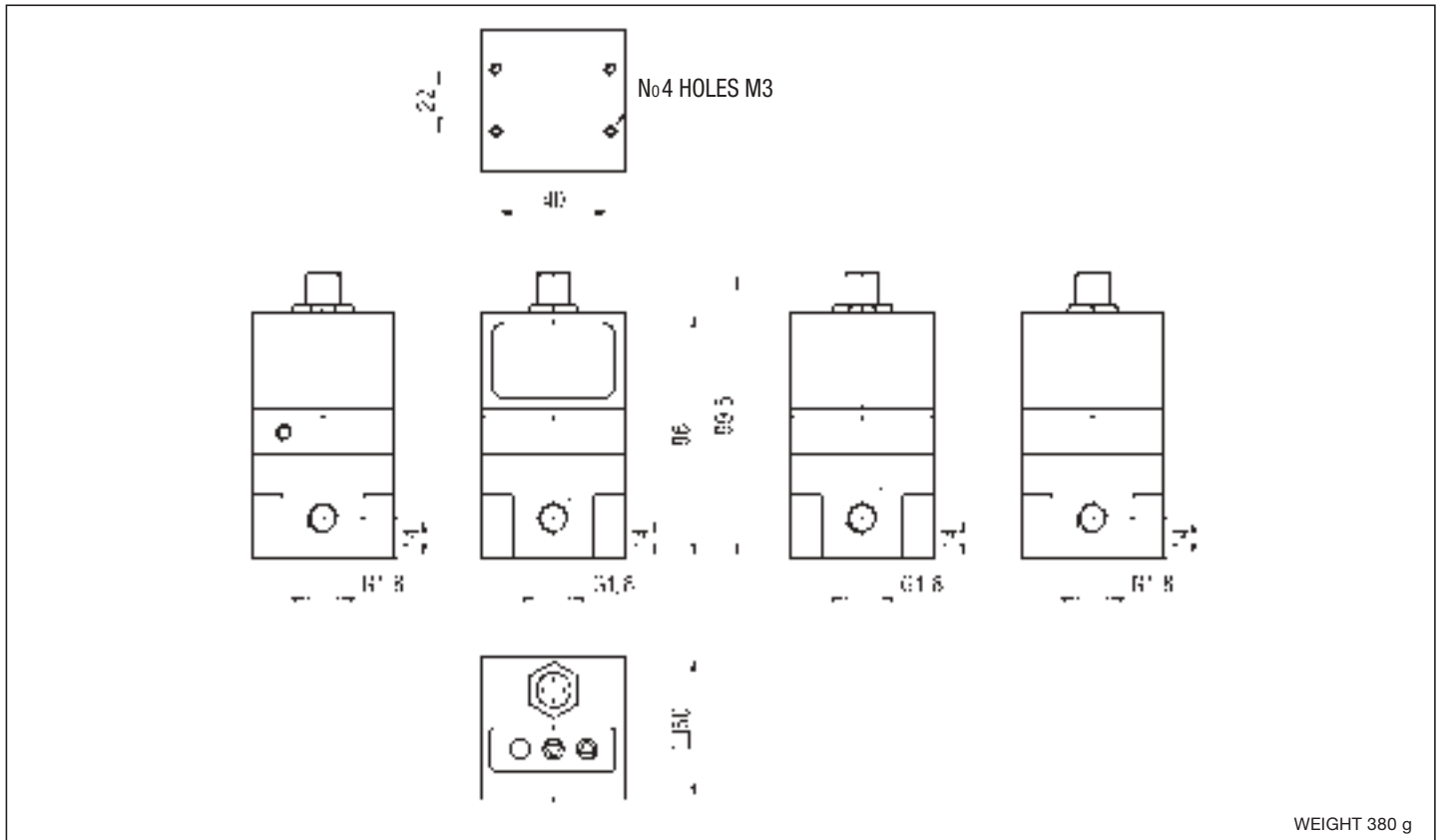

4

DIMENSIONS AND WEIGHT SIZE G1/4

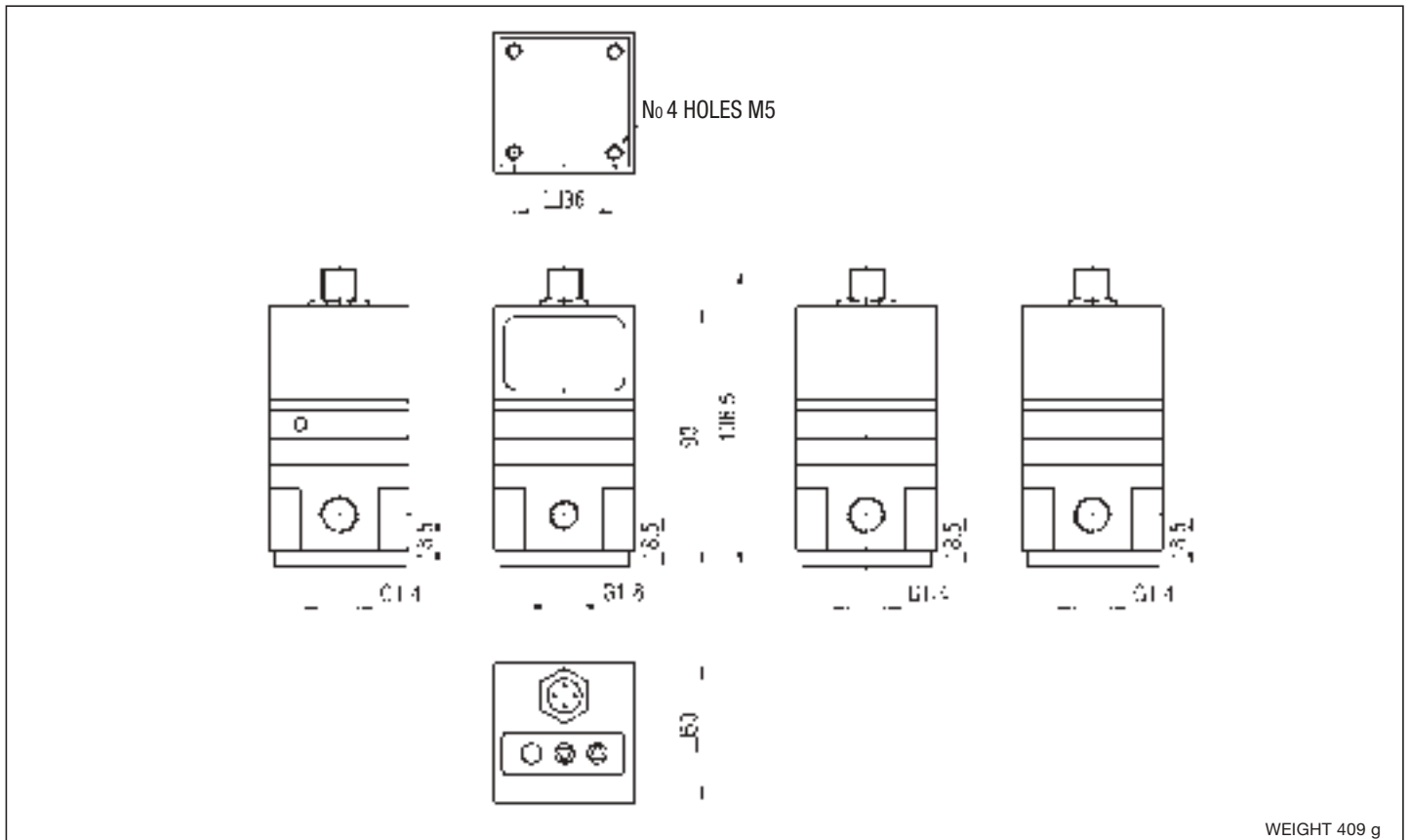

DIMENSIONS AND WEIGHT SIZE G1/2

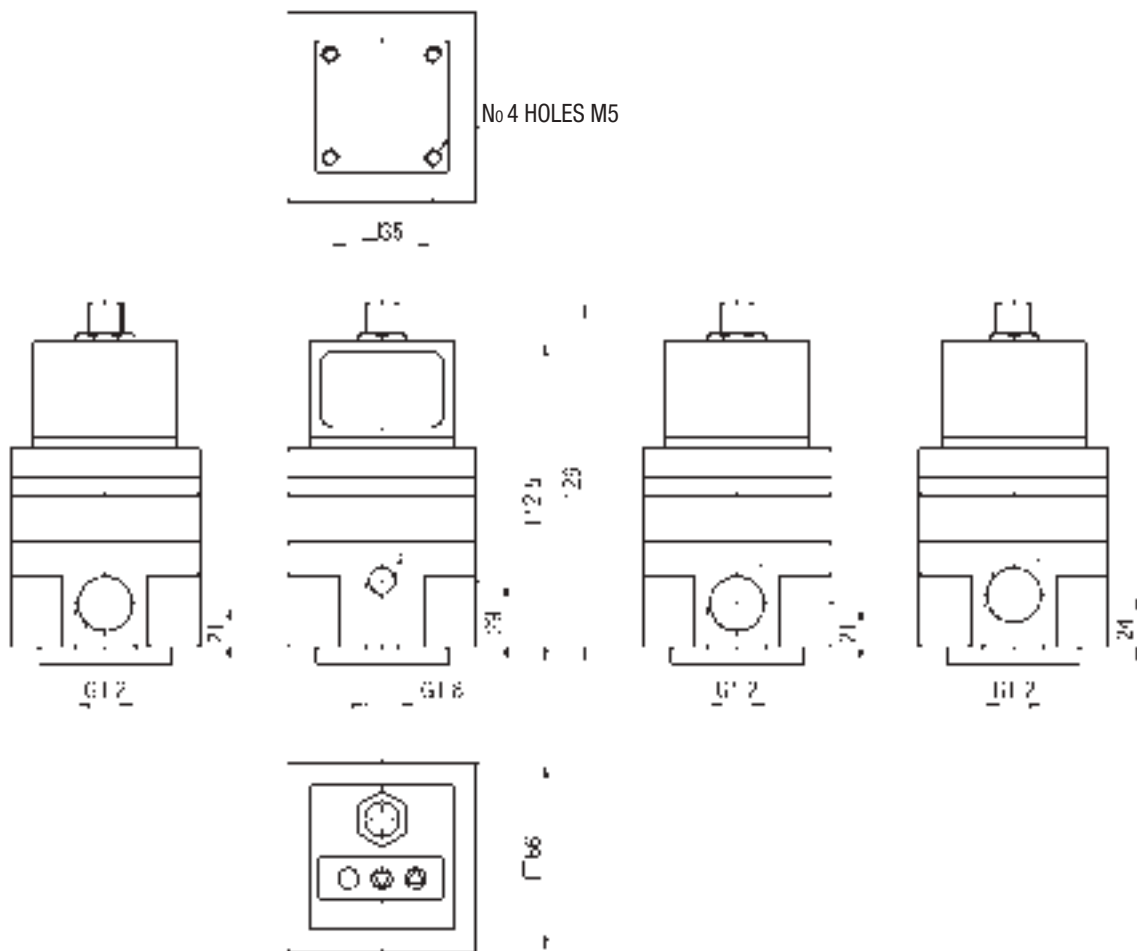

WEIGHT 753 g

4

HORIZONTAL FLANGE - FO

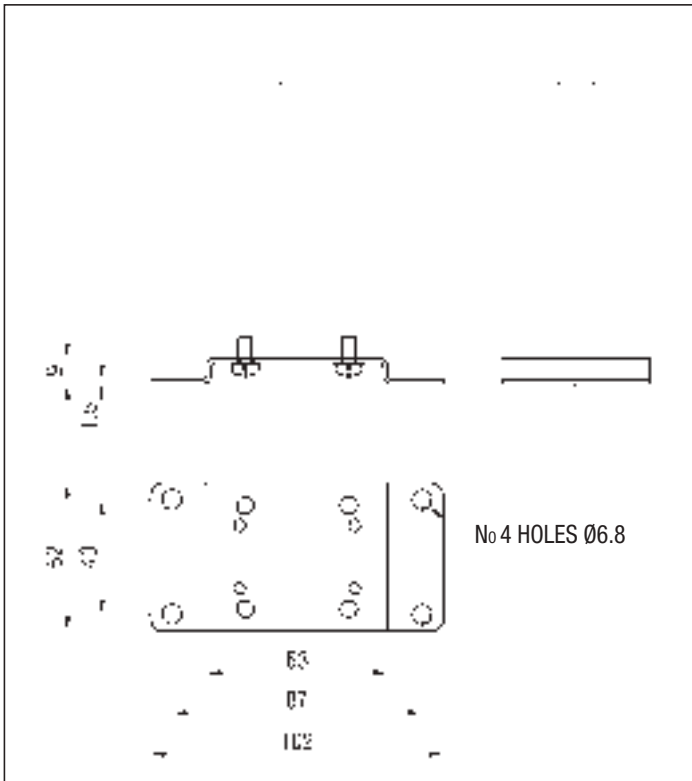

Supplied complete with screws

90° FLANGE - F90

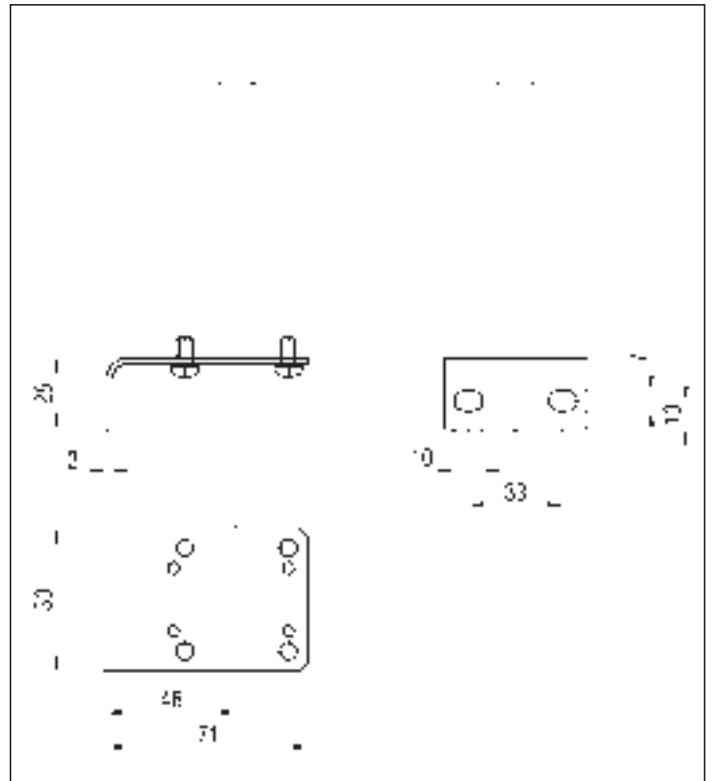

Supplied complete with screws

EXTENSION WITH M12 IN LINE CONNECTOR CABLE - M12L

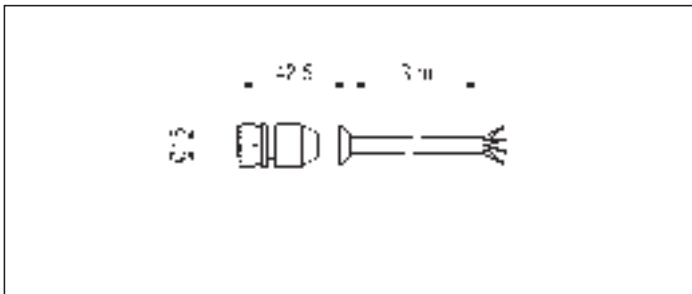

EXTENSION WITH M12 90° CONNECTOR CABLE - M12G

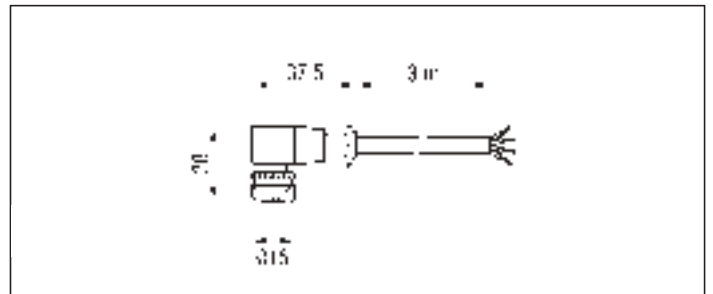

4

DESCRIPTION

Pressure gauges allow sensing the pressure in the pneumatic circuits. They are suitable to be applied directly on the pressure regulator or for panel mounting and they are available in the versions: axial (MA), radial (MR), with flange (MF) and with bracket (MP).



TECHNICAL DATA

Operating pressure	0 ÷ 1 bar; 0 ÷ 4 bar; 0 ÷ 6 bar; 0 ÷ 12 bar
Working temperature	0 ÷ +70 °C (-20 °C with dry air)
Fluid	Filtered, unlubricated or continuous lubricated compressed air
Accuracy	Cl. 1.6 (EN 837-1)
Dial	Ø 40 - 50 - 63 - 100
Port size	G1/8 - G1/4
Fixing	Type MA - Direct axial mounting Type MR - Direct radial mounting Type MF - Panel mounting with flange Type MP - Panel mounting with bracket

MATERIALS

Case	Type MA: Black ABS Type MR: Black ABS Type MF: Black painted steel Type MP: Galvanized steel
Gauge crystal	Kostil
Port	Brass
Spring	Copper
Movement	Brass
Dial	White ABS

AXIAL GAUGES TYPE MA

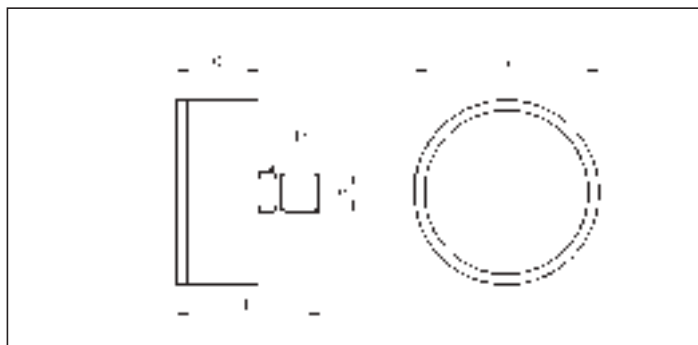

G	A	C	Ch	E	TYPE				WEIGHT (g)
					0 ÷ 1 bar	0 ÷ 4 bar	0 ÷ 6 bar	0 ÷ 12 bar	
G 1/8	40	24	12	40	MA 4/1	MA 4/4	MA 4/6	MA 4/12	48
G 1/8	52	28	14	52	MA 5/1	MA 5/4	MA 5/6	MA 5/12	75
G 1/4	63	29,5	14	54	MA 6/1	MA 6/4	MA 6/6	MA 6/12	90
G 3/8	100	36	17	65	-	-	-	MA 10/12	230

RADIAL GAUGES TYPE MR

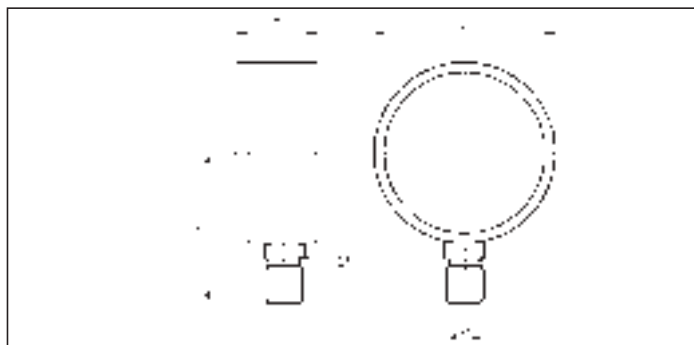

G	A	C	Ch	E	TYPE				WEIGHT (g)
					0 ÷ 1 bar	0 ÷ 4 bar	0 ÷ 6 bar	0 ÷ 12 bar	
G 1/8	40	24	12	37	MR 4/1	MR 4/4	MR 4/6	MR 4/12	42
G 1/8	51	28	14	48	MR 5/1	MR 5/4	MR 5/6	MR 5/12	68
G 1/4	63	29,5	14	54	MR 6/1	MR 6/4	MR 6/6	MR 6/12	84
G 3/8	100	36	17	78	-	-	-	MR 10/12	230

AXIAL GAUGES WITH FLANGE TYPE MF

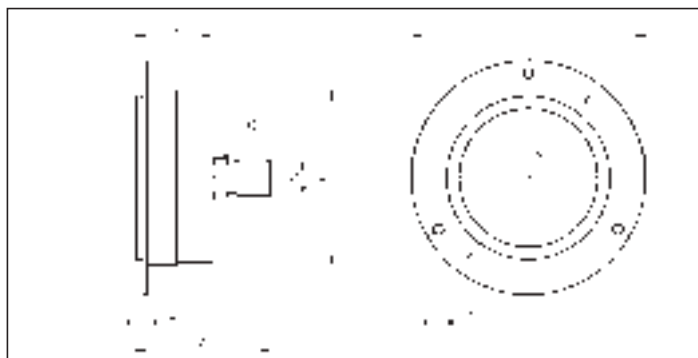

G	A	B	C	Ch	D	E	F	H
G 1/8	40,5	25,5	4	11	61	51	40,5	3,6
G 1/8	45	29	4	14	74,5	60	52,5	3,6
G 1/4	46,5	30	5,5	14	84,7	75	63,7	3,6
G 3/8	61	30	5	17	132	118	100,5	6

G	D	TYPE				WEIGHT (g)
		0 ÷ 1 bar	0 ÷ 4 bar	0 ÷ 6 bar	0 ÷ 12 bar	
G 1/8	61	MF 4/1	MF 4/4	MF 4/6	MF 4/12	82
G 1/8	74,5	MF 5/1	MF 5/4	MF 5/6	MF 5/12	120
G 1/4	84,7	MF 6/1	MF 6/4	MF 6/6	MF 6/12	150
G 3/8	132	-	-	-	MF 10/12	250

AXIAL GAUGES WITH BRACKET TYPE MP

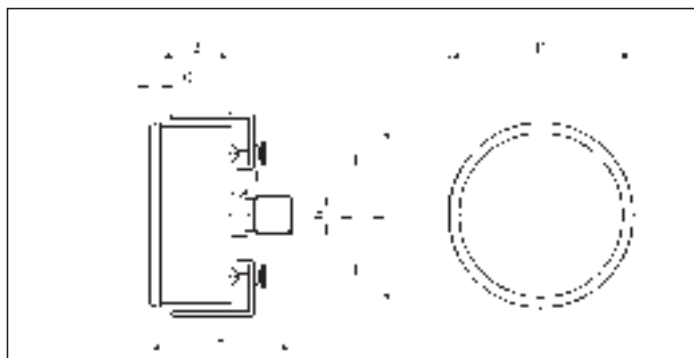

G	A	B	C	Ch	D	E	F
G 1/8	43	21	5	12	43	28	39
G 1/8	46	23	6	14	55,5	35	49
G 1/4	48	23	6	14	63,8	43	59

G	D	TYPE				WEIGHT (g)
		0 ÷ 1 bar	0 ÷ 4 bar	0 ÷ 6 bar	0 ÷ 12 bar	
G 1/8	43	MP 4/1	MP 4/4	MP 4/6	MP 4/12	82
G 1/8	55,5	MP 5/1	MP 5/4	MP 5/6	MP 5/12	120
G 1/4	63,8	MP 6/1	MP 6/4	MP 6/6	MP 6/12	150

DIGITAL/ANALOG PRESSURE SWITCH SERIES PRDA

This series of switches has been expressly designed for the pressure detection of a wide range of fluids with elevate accuracy and resolution. This series has both digital and/or analog outputs and an integrated display with a frontal interface including three buttons to programme different functions (all described in the documentation that goes with the item) among which:

- setting the unit of measurement of the pressure;
- managing the outputs No.1 and No.2, depending on the set pressures.

This pressure switch, thanks to the very compact dimensions and to the 3 1/2 digit led display, is a very versatile item and suitable for the majority of the applications with not corrosive and incombustible gases, and with air. It is supplied completed with front protection cover and panel mounting system type SFPR.

TECHNICAL DATA

Working temperature	0 ÷ +50 °C
Operating/setting pressure	-1 ÷ 10 bar (0 ÷ 10 bar recommended)
Power supply voltage	DC: 12 ÷ 24 V ± 10%
Fluid	Air; not corrosive and incombustible gases
Max. load current	80 mA
Average current consumption	55 mA
Protection class	IP 50
Response time	< 2.5 ms
Display accuracy	<± 2% F.S. ± 1 digit with ambient temperature of 25 ± 3 °C
Analog output	1 ÷ 5 V < ± 2.5%
Linearity analog output	± 1% F.S.
Display resolution	3 1/2 digit 7 segments LED (sampling frequency: 5 Hz)
Switch output	PNP; (NPN on request)
Unit of measurement	kPa, MPa, Bar, Psi
Hysteresis	Manually adjustable between the 1 to 10% of the rated pressure, or automatically arranged approximately to the 3% F.S.



DIMENSIONS AND WEIGHT - PRDA

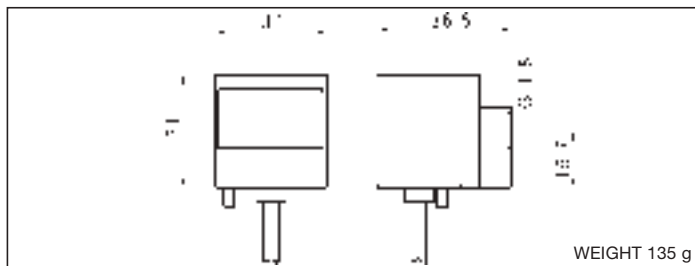

PROTECTION COVER AND PANEL MOUNTING SYSTEM SFPR*

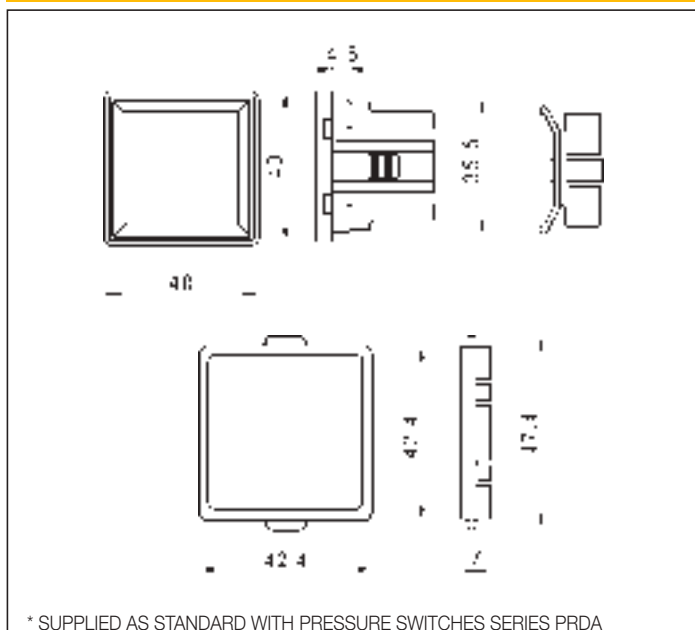

MATERIALS

Parts in contact with measured fluid	Carbon steel
Lead wire	5-conductors oil-proof cable
Electric connections	Brown: DC + Blue: DC - Black: OUT 1 White: OUT 2 Orange: Analog output

INTERNAL CIRCUIT AND WIRING - PNP

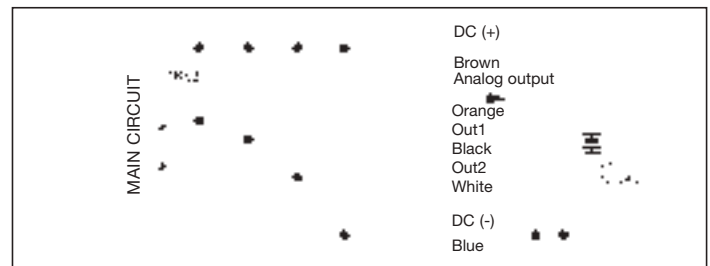

TOTAL DIMENSIONS WITH SFPR

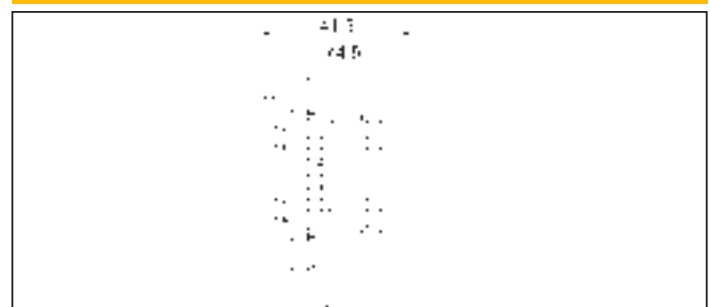

FRONTAL INTERFACE PRDA

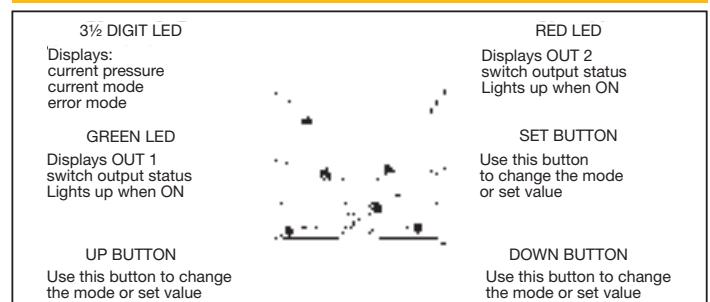

4

FIXING BRACKETS STPR (pair)

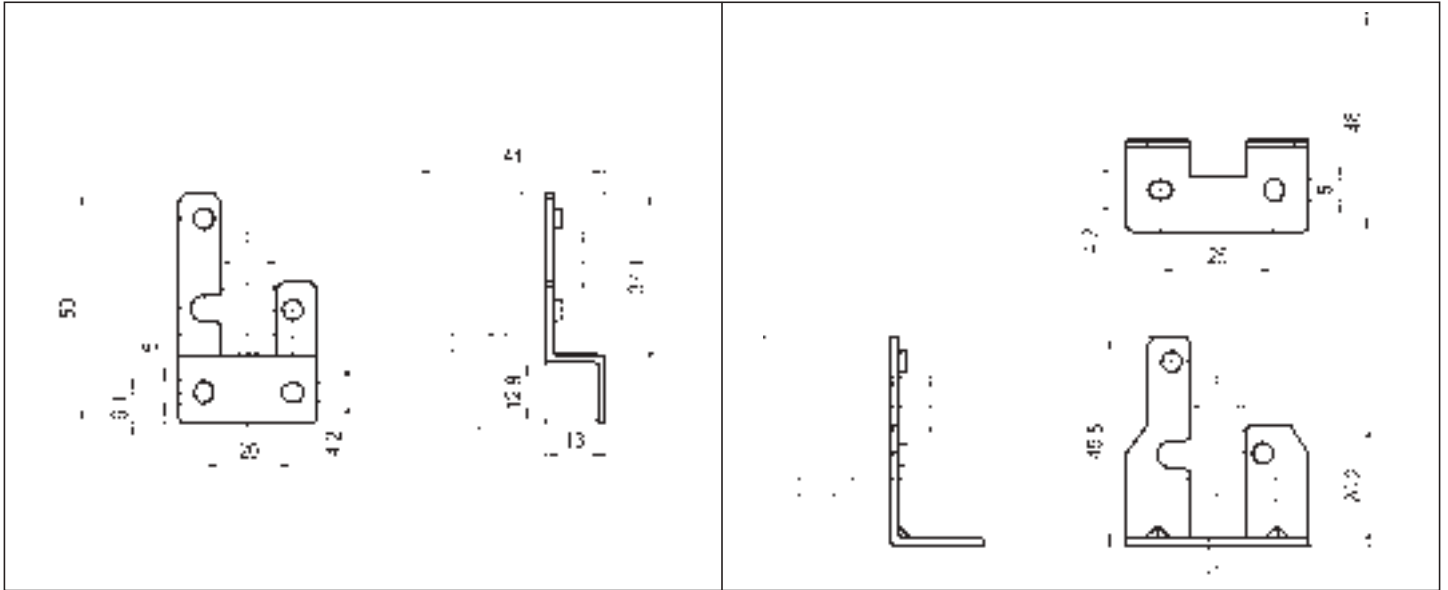

DIAPHRAGM PRESSURE SWITCH SERIES PRC-PRA

TECHNICAL DATA

Max. switched voltage	48 V AC - DC
Max. switched current	0,5 A
Max. fluid temperature	80 ÷ 120 °C
Adjusting range	1 ÷ 10 bar
Static overpressure	80 bar
Tolerance at 20 °C	0,5 bar
Hysteresis	6 ÷ 10% of setting value
Max. number of insertions	200 per minute

MATERIALS

Body	Brass
Diaphragm	FPM (Viton®)
Fixed contact	Silver
Moving contact	Phosphorous bronze with silver contact

PRC - PRA

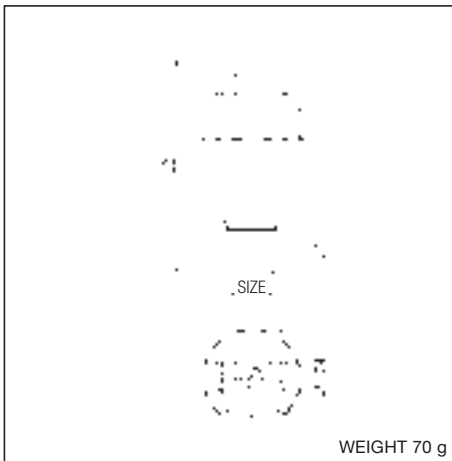

CONNECTOR (protection class IP54) - CN/PR54



CONNECTOR (protection class IP65) - CN/PR65

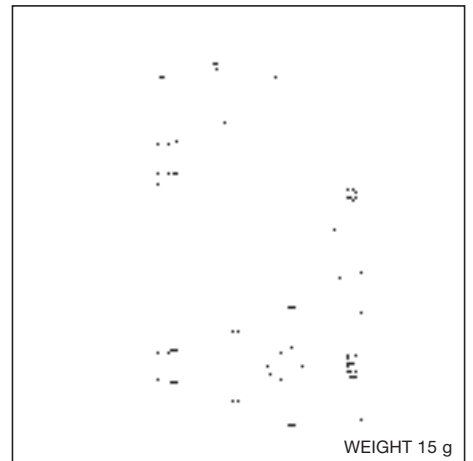

Symbol N.C.	Size	L1	L2	TYPE
	G 1/8	10	51	PRC8
	G 1/4	12	53	PRC4

Symbol N.O.	Size	L1	L2	TYPE
	G 1/8	10	51	PRA8
	G 1/4	12	53	PRA4

CONTACTS EXCHANGE PRESSURE SWITCH SERIES PRCA

TECHNICAL DATA

Max. switched voltage	250 V AC; 30 V DC
Max. switched current	5 A in AC; 4 A in DC
Max. fluid temperature	100 °C
Protection class	IP 65
Adjusting range	0,5 ÷ 10 bar
Static overpressure	150 bar
Tolerance at 20 °C	0,2 bar
Hysteresis	15 ÷ 30% of setting value
Max. number of insertions	200 per minute
Connector (included)	ULR4P

MATERIALS

Body	Passivated steel
Electric box	Anodized aluminium alloy
Diaphragm	FPM (Viton®)

PRCA

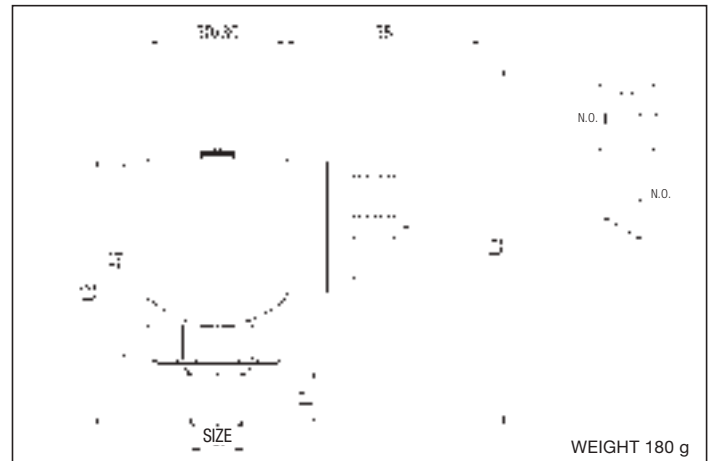

Symbol N.C. / N.O.	Size	L1	L2	L3	TYPE*
	G 1/8	10	56	74	PRCA8
	G 1/4	12	53	76	PRCA4

* These switches can rotate of 360°



Series RT

Push-in techno-polymer fittings.....page 5.3

Series RO

Push-in brass fittingspage 5.12

Series RS

Standard fittings.....page 5.25

Series RC

Push-on brass fittingspage 5.36

Series RG

Compression fittingspage 5.46

Series VS

Mini ball-valves.....page 5.50

Silencers.....page 5.52

Series T

Polyurethane tubes (PU 98 ShA).....page 5.53

Polyamide tubes (PA12)page 5.54

Polyethylene tubes (PELD).....page 5.55

TECHNICAL DATA

Body material	Acetal resin
Thread	Metric and parallel
Seal	NBR rubber
Clamp	Stainless steel
Size	M5 ÷ G 1/2
Fluid	Air, vacuum
Working temperature	0 ÷ 60 °C
Operating pressure	0 - 10 bar
Negative pressure	-750 mmHg (-1 bar)
Max. pressure	Fittings: 15 bar - Flow regulators: 10 bar
Recommended tubes materials	Polyamide and Polyurethane

5

STRAIGHT MALE

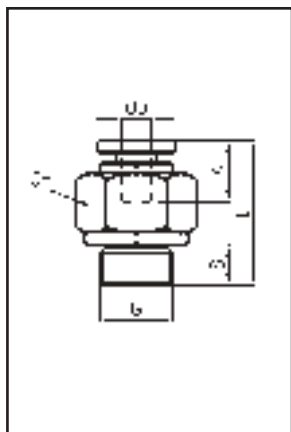

TYPE	L	A	B	ØD	G	CH	q.ty
RT-DM-4/M5	19,3	14	4	4	M5	10	10
RT-DM-6/M5	20,7	15	4	6	M5	12	10
RT-DM-4/01	19,5	14,6	5,5	4	G1/8	14	10
RT-DM-4/02	18,1	14,6	7,5	4	G1/4	17	10
RT-DM-6/01	20,7	15,2	5,5	6	G1/8	14	10
RT-DM-6/02	22,1	15,2	7,5	6	G1/4	17	10
RT-DM-8/01	25,1	16,2	5,5	8	G1/8	14	10
RT-DM-8/02	23,5	16,2	7,5	8	G1/4	17	10
RT-DM-8/03	21,1	16,2	8,5	8	G3/8	20	10
RT-DM-8/04	25,1	16,2	11	8	G1/2	24	10
RT-DM-10/02	29,3	18,7	7,5	10	G1/4	17	10
RT-DM-10/03	26,8	18,7	8,5	10	G3/8	20	10
RT-DM-10/04	25,1	18,7	11	10	G1/2	24	10
RT-DM-12/03	29,6	21,7	8,5	12	G3/8	21	10
RT-DM-12/04	30,6	21,7	11	12	G1/2	24	10
RT-DM-16/04	40	24,5	11	16	G1/2	24	10

STRAIGHT FEMALE

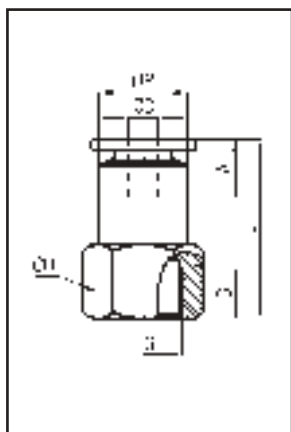

TYPE	L	A	B	ØD	G	ØP	CH	q.ty
RT-DF-4/01	23,5	14,6	7	4	G1/8	10	14	10
RT-DF-6/01	24,4	15,2	7	6	G1/8	12	14	10
RT-DF-6/02	27,4	15,2	10	6	G1/4	12	17	10
RT-DF-8/01	25,1	16,2	7	8	G1/8	14	14	10
RT-DF-8/02	28,1	16,2	10	8	G1/4	14	17	10
RT-DF-8/03	29,1	16,2	11	8	G3/8	14	21	10
RT-DF-10/02	30,5	18,7	10	10	G1/4	17	17	10
RT-DF-10/03	31,5	18,7	11	10	G3/8	17	21	10
RT-DF-12/03	34,6	21,7	11	12	G3/8	20	21	10
RT-DF-12/04	36,6	21,7	13	12	G1/2	20	24	10

SWIVELLING ELBOW MALE

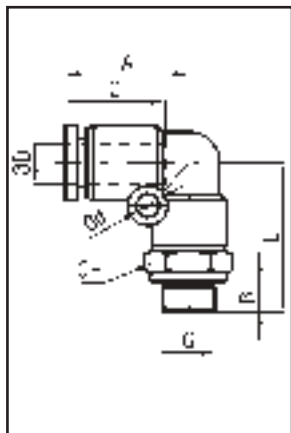

TYPE	L	A	B	C	Ød	ØD	G	CH	q.ty
RT-G-4/M5	18	16	4	13	-	4	M5	8	10
RT-G-6/M5	18	20	4	16	-	6	M5	8	10
RT-G-4/01	24,5	17,7	5,5	15,1	3,2	4	G1/8	14	10
RT-G-4/02	27	17,7	7,5	15,1	3,2	4	G1/4	17	10
RT-G-6/01	25,7	19,3	5,5	16	3,2	6	G1/8	14	10
RT-G-6/02	28,2	19,3	7,5	16	3,2	6	G1/4	17	10
RT-G-8/01	29	22,8	5,5	18,1	3,2	8	G1/8	14	10
RT-G-8/02	31,5	22,8	7,5	18,1	3,2	8	G1/4	17	10
RT-G-8/03	33	22,8	8,5	18,1	3,2	8	G3/8	20	10
RT-G-8/04	37	22,8	11	18,1	3,2	8	G1/2	24	10
RT-G-10/02	35,8	27,6	7,5	20,4	4,2	10	G1/4	17	10
RT-G-10/03	37,3	27,6	8,5	20,4	4,2	10	G3/8	20	10
RT-G-10/04	41,3	27,6	11	20,4	4,2	10	G1/2	24	10
RT-G-12/03	39	29,6	8,5	23,2	4,2	12	G3/8	21	10
RT-G-12/04	45,5	33	11	24,5	5,1	12	G1/2	24	10
RT-G-16/04	45,5	33	11	24,6	5,1	17	G1/2	24	10

SWIVELLING LONG ELBOW MALE

5

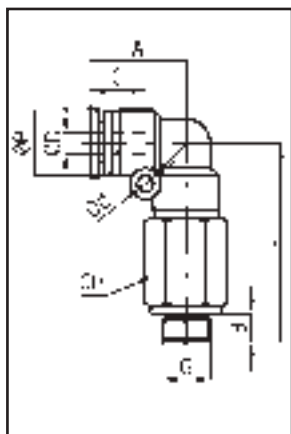

TYPE	L	A	B	C	Ød	ØD	G	ØP	CH	q.ty
RT-GL-4/M5	35	18	4	17	-	4	M5	11	10	10
RT-GL-6/M5	37	20	4	19	6	6	M5	13	12	10
RT-GL-4/01	35,5	17,7	5,5	15,1	3,2	4	G1/8	11	14	10
RT-GL-4/02	39	17,7	7,5	15,1	3,2	4	G1/4	11	17	10
RT-GL-6/01	39,2	19,3	5,5	16	3,2	6	G1/8	13	14	10
RT-GL-6/02	42,2	19,3	7,5	16	3,2	6	G1/4	13	17	10
RT-GL-6/03	43,7	19,3	8,5	16	3,2	6	G3/8	13	20	10
RT-GL-8/01	44,3	22,8	5,5	18,1	3,2	8	G1/8	14,8	14	10
RT-GL-8/02	46,8	22,8	7,5	18,1	3,2	8	G1/4	14,8	17	10
RT-GL-8/03	48,4	22,8	8,5	18,1	3,2	8	G3/8	14,8	20	10
RT-GL-10/02	56,3	27,6	7,5	20,4	4,2	10	G1/4	18,4	17	10
RT-GL-10/03	57,3	27,6	8,5	20,4	4,2	10	G3/8	18,4	20	10
RT-GL-10/04	60,8	27,6	11	20,4	4,2	10	G1/2	18,4	24	10
RT-GL-12/03	62,5	29,6	8,5	23,2	4,2	12	G3/8	21	21	10
RT-GL-12/04	65,5	29,6	11	23,2	4,2	12	G1/2	21	24	10

SWIVELLING CENTRAL TEE

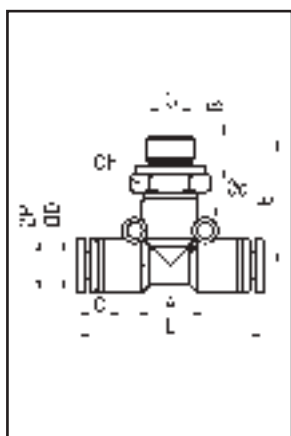

TYPE	L	A	B	C	Ød	ØD	E	G	ØP	CH	q.ty
RT-TC-4/M5	37	15	4	15	5	4	23,5	M5	11	10	10
RT-TC-6/M5	39	16	4	16	6	6	24,5	M5	13	12	10
RT-TC-4/01	37,4	14	5,5	15,1	3,2	4	25,5	G1/8	11	14	10
RT-TC-6/01	39,2	16	5,5	16	3,2	6	26	G1/8	13	14	10
RT-TC-6/02	39,2	16	7,5	16	3,2	6	28,5	G1/4	13	17	10
RT-TC-8/01	45,5	18	5,5	18,1	3,2	8	29	G1/8	14,8	14	10
RT-TC-8/02	45,5	18	7,5	18,1	3,2	8	31,5	G1/4	14,8	17	10
RT-TC-8/03	45,5	18	8,5	18,1	3,2	8	33	G3/8	14,8	20	10
RT-TC-10/02	56,3	24	7,5	20,4	4,2	10	36,5	G1/4	18,4	17	10
RT-TC-10/03	56,3	24	8,5	20,4	4,2	10	38	G3/8	18,4	20	10
RT-TC-10/04	56,3	24	11	20,4	4,2	10	42	G1/2	18,4	24	10
RT-TC-12/03	59,2	27	8,5	23,2	4,2	12	39	G3/8	21	21	10
RT-TC-12/04	59,2	27	11	23,2	4,2	12	43	G1/2	21	24	10

SWIVELLING LATERAL TEE

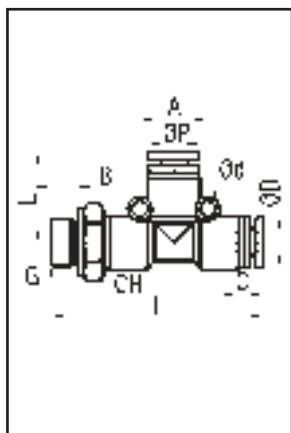

TYPE	L	A	B	C	E	Ød	ØD	G	ØP	CH	q.ty
RT-TL-4/M5	41	14	4	12	18	5	4	M5	11	10	10
RT-TL-6/M5	42,3	16	4	15	18,5	6	6	M5	13	12	10
RT-TL-4/01	44,2	14	5,5	15,1	18,7	3,2	4	G1/8	11	14	10
RT-TL-6/01	45,6	16	5,5	16	19,6	3,2	6	G1/8	13	14	10
RT-TL-6/02	48,1	16	7,5	16	19,6	3,2	6	G1/4	13	17	10
RT-TL-8/01	51,7	18	5,5	18,1	22,8	3,2	8	G1/8	14,8	14	10
RT-TL-8/02	54,2	18	7,5	18,1	22,8	3,2	8	G1/4	14,8	17	10
RT-TL-8/03	55,7	18	8,5	18,1	22,8	3,2	8	G3/8	14,8	20	10
RT-TL-10/02	64,8	24	7,5	20,4	28,3	4,2	10	G1/4	18,4	17	10
RT-TL-10/03	66,3	24	8,5	20,4	28,3	4,2	10	G3/8	18,4	20	10
RT-TL-10/04	70,3	24	11	20,4	28,3	4,2	10	G1/2	18,4	24	10
RT-TL-12/03	68,6	27	8,5	23,2	29,6	4,2	12	G3/8	21	21	10
RT-TL-12/04	72,6	27	11	23,2	29,6	4,2	12	G1/2	21	24	10

SWIVELLING MALE Y

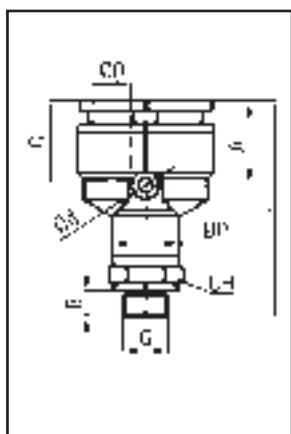

TYPE	L	A	B	C	Ød	ØD	G	ØP	CH	q.ty
RT-YM-4/M5	40	14	4	14	6	4	M5	11	10	10
RT-YM-6/M5	41	14	4	14	6	6	M5	13	12	10
RT-YM-4/01	35,5	10	5,5	15,1	3,2	4	G1/8	11	14	10
RT-YM-6/01	39,2	10,5	5,5	16	3,2	6	G1/8	13	14	10
RT-YM-6/02	42,2	10,5	7,5	16	3,2	6	G1/4	13	17	10
RT-YM-8/01	44,3	13,4	5,5	18,1	3,2	8	G1/8	14,8	14	10
RT-YM-8/02	46,8	13,4	7,5	18,1	3,2	8	G1/4	14,8	17	10
RT-YM-8/03	48,4	13,4	8,5	18,1	3,2	8	G3/8	14,8	20	10
RT-YM-10/02	56,3	15,5	7,5	20,4	4,2	10	G1/4	18,4	17	10
RT-YM-10/03	57,3	15,5	8,5	20,4	4,2	10	G3/8	18,4	20	10
RT-YM-10/04	60,8	15,5	11	20,4	4,2	10	G1/2	18,4	24	10
RT-YM-12/03	62,5	15,5	8,5	23,2	4,2	12	G3/8	21	21	10
RT-YM-12/04	65,5	15,5	11	23,2	4,2	12	G1/2	21	24	10

SWIVELLING LOW ELBOW

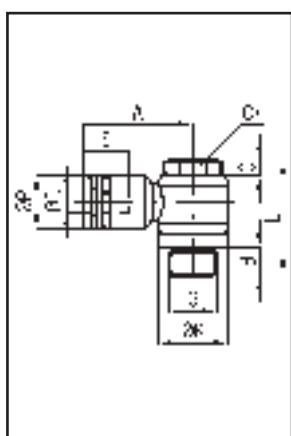

TYPE	L	A	B	C	ØD	E	G	ØK	ØP	CH	q.ty
RT-GG-4/M5	17	22,5	4	3	4	12	M5	10	11	8	10
RT-GG-6/M5	17	23,4	4	3	6	17	M5	10	13	8	10
RT-GG-4/01	23,5	22,5	5,7	3	4	15,1	G1/8	14,4	11	14	10
RT-GG-6/01	23,5	23,4	5,7	3	6	16	G1/8	14,4	13	14	10
RT-GG-6/02	27	25,5	8,3	4	6	16	G1/4	18,3	13	17	10
RT-GG-8/01	23,5	25,6	5,7	3	8	18,1	G1/8	14,4	14,8	14	10
RT-GG-8/02	27	28,7	8,3	4	8	18,1	G1/4	18,3	14,8	17	10
RT-GG-8/03	32,7	29,6	13,9	4,5	8	18,1	G3/8	22	14,8	21	10
RT-GG-10/02	27	33,1	8,3	4	10	20,4	G1/4	18,3	18,4	17	10
RT-GG-10/03	32,7	32,9	13,9	4,5	10	20,4	G3/8	22	18,4	21	10
RT-GG-10/04	38,1	35,9	11	5,5	10	20,4	G1/2	28	18,4	24	10
RT-GG-12/03	32,7	35,6	13,9	4,5	12	23,2	G3/8	22	21	21	10
RT-GG-12/04	38,1	36,6	11	5,5	12	23,2	G1/2	28	21	24	10

SWIVELLING LATERAL MULTI-TEE

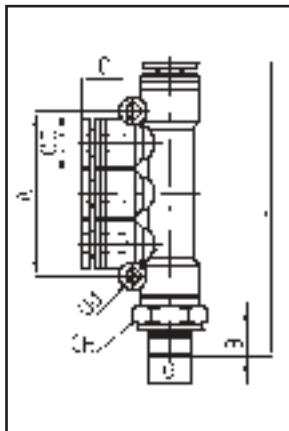

TYPE	L	A	B	C	Ød	ØD	G	CH	q.ty
RT-MTL-4/01	64,2	36	5,5	15,1	3,2	4	G1/8	14	10
RT-MTL-4/02	66,7	36	7,5	15,1	3,2	4	G1/4	17	10
RT-MTL-6/01	68,6	42	5,5	16	3,2	6	G1/8	14	10
RT-MTL-6/02	71,1	42	7,5	16	3,2	6	G1/4	17	10
RT-MTL-6/03	72,6	42	8,5	16	3,2	6	G3/8	20	10
RT-MTL-8/01	87,8	48	5,5	18,1	3,2	8	G1/8	14	10
RT-MTL-8/02	90,3	48	7,5	18,1	3,2	8	G1/4	17	10
RT-MTL-8/03	91,8	48	8,5	18,1	3,2	8	G3/8	20	10

SWIVELLING DIFFERENT Ø LATERAL MULTI-TEE

5

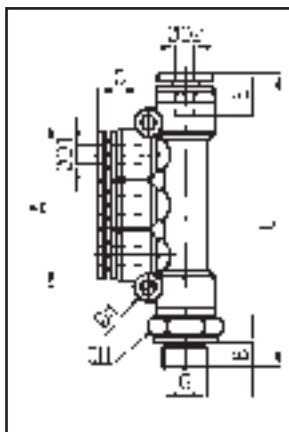

TYPE	L	A	B	C	Ød	ØD1	ØD2	E	G	CH	q.ty
RT-MDL6/4/01	64,2	36	5,5	16	3,2	4	6	15,1	G1/8	14	10
RT-MDL8/4/02	70,7	42	7,5	18,1	3,2	4	8	15,1	G1/4	17	10
RT-MDL8/6/02	71,1	42	7,5	18,1	3,2	6	8	16	G1/4	17	10
RT-MDL10/8/03	91,8	48	8,5	20,4	3,2	8	10	18,1	G3/8	20	10

UNION STRAIGHT

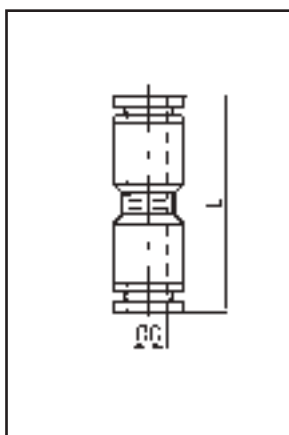

TYPE	L	ØD	q.ty
RT-DI-4	33	4	10
RT-DI-6	35,2	6	10
RT-DI-8	39,1	8	10
RT-DI-10	47,8	10	10
RT-DI-12	49,2	12	10
RT-DI-16	51	16	10

REDUCED UNION STRAIGHT

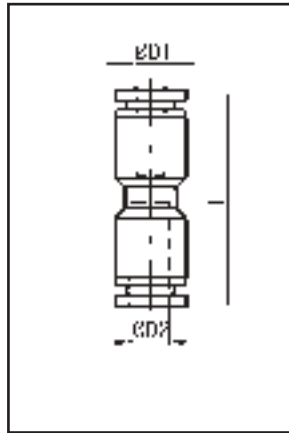

TYPE	L	ØD1	ØD2	q.ty
RT-DIR-6/4	34,9	6	4	10
RT-DIR-8/6	38,6	8	6	10
RT-DIR-10/8	47,3	10	8	10
RT-DIR-12/10	48,9	12	10	10
RT-DIR-16/12	51	16	12	10

UNION ELBOW

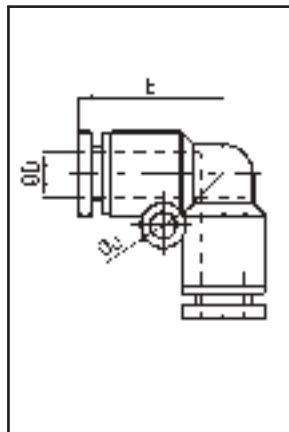

TYPE	ØD	Ød	E	q.ty
RT-GI-4	4	-	17,5	10
RT-GI-6	6	3,2	19	10
RT-GI-8	8	3,2	22,8	10
RT-GI-10	10	4,2	27,6	10
RT-GI-12	12	4,3	29,6	10
RT-GI-16	16	5,1	33	10

5

UNION TEE

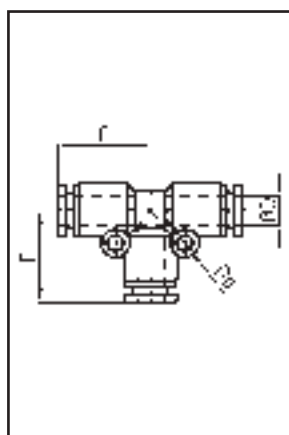

TYPE	ØD	Ød	E	q.ty
RT-TI-4	4	3,2	18,5	10
RT-TI-6	6	3,2	19,3	10
RT-TI-8	8	3,2	22,75	10
RT-TI-10	10	4,2	28,3	10
RT-TI-12	12	4,3	29,6	10

UNION Y

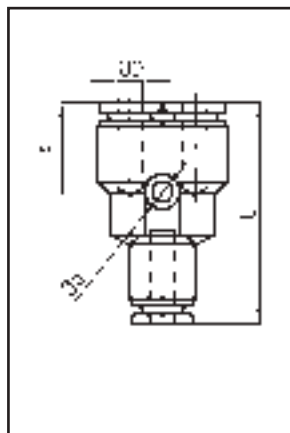

TYPE	L	Ød	ØD	F	q.ty
RT-YI-4	35,5	3,2	4	14	10
RT-YI-6	37,1	3,2	6	14,8	10
RT-YI-8	40,4	3,2	8	18,2	10
RT-YI-10	49,7	4,2	10	20,8	10
RT-YI-12	53,2	4,2	12	21,6	10

REDUCED UNION Y

5

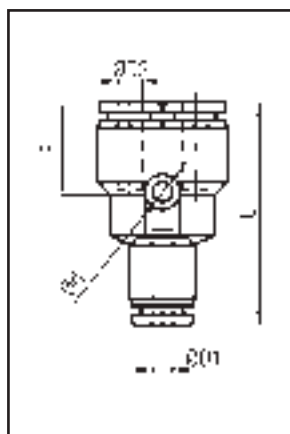

TYPE	L	Ød	ØD1	ØD2	F	q.ty
RT-YIR-6/4	36,8	3,2	6	4	14,5	10
RT-YIR-8/6	39,9	3,2	8	6	17,7	10
RT-YIR-10/8	49,2	4,2	10	8	20,3	10
RT-YIR-12/10	52,9	4,2	12	10	21,3	10
RT-YIR-16/12	62	5,1	16	12	24,5	10

CROSS JUNCTION

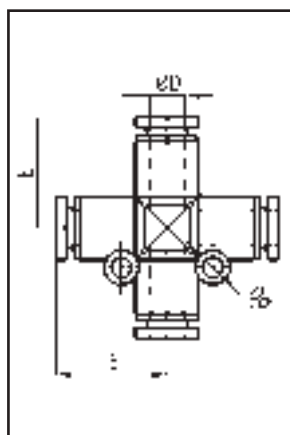

TYPE	ØD	Ød	E	q.ty
RT-C-4	4	3,2	17,5	10
RT-C-6	6	3,2	19,3	10
RT-C-8	8	3,2	22,75	10
RT-C-10	10	4,2	28,3	10
RT-C-12	12	4,3	29,6	10

MULTI-TEE

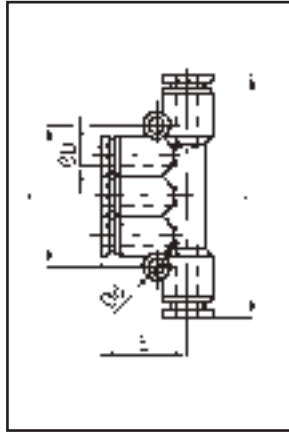

TYPE	L	Ød	ØD1	E	F	q.ty
RT-MT-4	57	3,2	4	19	36	10
RT-MT-6	61	3,2	6	20,3	42	10
RT-MT-8	81,6	3,2	8	24,3	48	10

DIFFERENT Ø MULTI-TEE

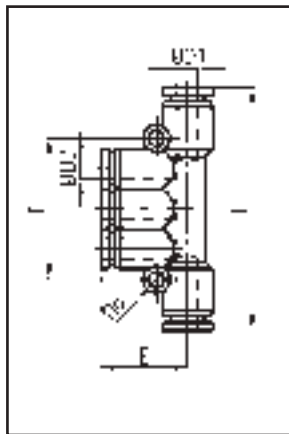

TYPE	L	Ød	ØD1	ØD2	E	F	q.ty
RT-MTD-6/4	57,6	3,2	6	4	19	36	10
RT-MTD-8/4	62,6	3,2	8	4	20	42	10
RT-MTD-8/6	62,6	3,2	8	6	20,3	42	10
RT-MTD-10/6	77,3	3,2	10	6	23,8	48	10
RT-MTD-10/8	77,3	3,2	10	8	24,3	48	10

5

REDUCER

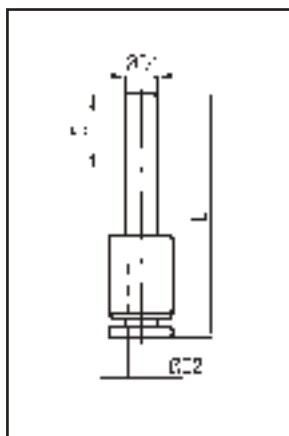

TYPE	L	C	ØD1	ØD2	q.ty
RT-RC-6/4	42	17	6	4	10
RT-RC-8/4	44,5	18	8	4	10
RT-RC-8/6	45	18	8	6	10
RT-RC-10/6	47	20	10	6	10
RT-RC-10/8	47	20	10	8	10
RT-RC-12/8	54	23,5	12	8	10
RT-RC-12/10	54,5	23,5	12	10	10

BULKHEAD CONNECTOR

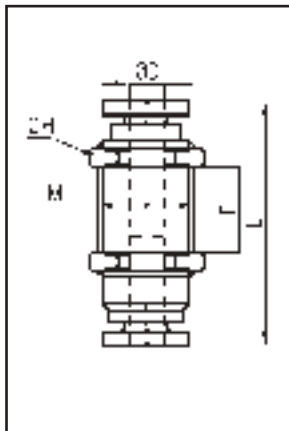

TYPE	L	ØD	E	M	CH	q.ty
RT-P-4	30,1	4	9,7	M12	14	10
RT-P-6	31,8	6	7,5	M14	17	10
RT-P-8	35,3	8	6,8	M16	19	10
RT-P-10	41,6	10	11,5	M20	24	10
RT-P-12	45,3	12	12,8	M22	27	10

MALE PLUG

5

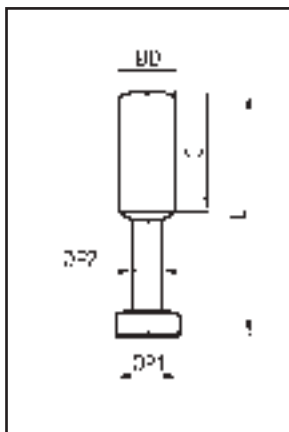
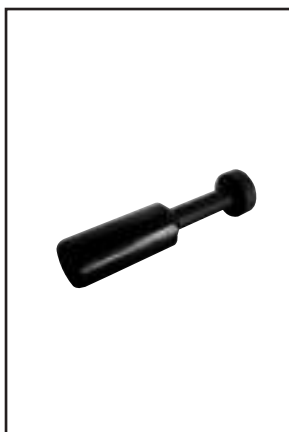

TYPE	L	C	ØD	ØP1	ØP2	q.ty
RT-TM-4	28	15	4	5	3	10
RT-TM-6	33	17	6	7	3	10
RT-TM-8	37	18	8	9	4	10
RT-TM-10	42	20,5	10	11	5	10
RT-TM-12	44	23	12	13	6	10

SWIVELLING MALE/FEMALE ELBOW

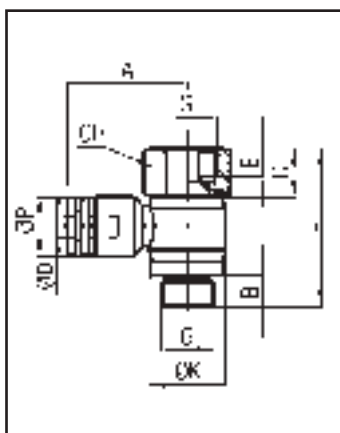

TYPE	L	A	B	C	ØD	E	G	ØK	ØP	CH	q.ty
RT-GMF-4/01	29,5	22,5	5,7	9	4	7	G1/8	14,4	11	14	10
RT-GMF-4/02	35	23,6	8,3	12	4	10	G1/4	18,3	11	17	10
RT-GMF-6/01	29,5	23,4	5,7	9	6	7	G1/8	14,4	13	14	10
RT-GMF-6/02	35	25,5	8,3	12	6	10	G1/4	18,3	11	17	10
RT-GMF-8/01	29,5	25,6	5,7	9	8	7	G1/8	14,4	14,8	14	10
RT-GMF-8/02	35	28,7	8,3	12	8	10	G1/4	18,3	14,8	17	10
RT-GMF-8/03	41,2	29,6	13,9	13	8	11	G3/8	22	14,8	21	10
RT-GMF-8/04	47	32,6	11	14,4	8	13	G1/2	28	14,8	24	10
RT-GMF-10/02	35	33,1	8,3	12	10	10	G1/4	18,3	18,4	17	10
RT-GMF-10/03	41,2	32,9	13,9	13	10	11	G3/8	22	18,4	21	10
RT-GMF-10/04	47	35,9	11	14,4	10	13	G1/2	28	18,4	24	10
RT-GMF-12/02	35	33,5	8,3	12	12	10	G1/4	18,3	21	21	10
RT-GMF-12/03	41,2	35,6	13,9	13	12	11	G3/8	22	21	21	10
RT-GMF-12/04	47	36,6	11	14,4	12	13	G1/2	28	21	24	10

INLINE UNIDIRECTIONAL FLOW REGULATOR

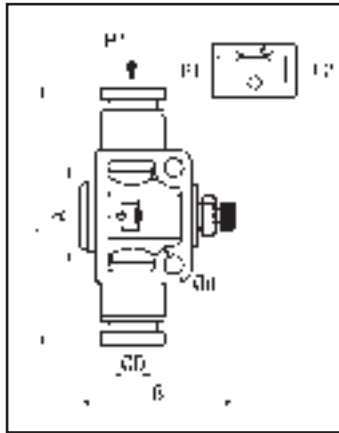

TYPE	L	A	B	Ød	ØD	q.ty
RT-RFL-4	39,5	14	25,7	3,2	4	10
RT-RFL-6	47,6	20	41,9	4,3	6	10
RT-RFL-8	52,6	22	45,6	4,3	8	10
RT-RFL-10	63,1	26	52,3	4,3	10	10
RT-RFL-12	74,2	32	55	4,3	12	10

UNIDIRECTIONAL FLOW REGULATOR FOR CYLINDER (OUT)



TYPE	L	A	B	C	ØD	G	ØP	CH	q.ty
RT-RF-4/M5	28,2	21	5	12	4	M5	11	8	10
RT-RF-6/M5	28,2	21	-	-	6	M5	13	8	10
RT-RF-4/01	41,1	22,5	5,7	15,1	4	G1/8	10	10	10
RT-RF-4/02	48,8	24,3	8,3	15,1	4	G1/4	10	14	10
RT-RF-6/01	41,1	23,4	5,7	16	6	G1/8	12	10	10
RT-RF-6/02	48,8	25,5	8,3	16	6	G1/4	12	14	10
RT-RF-8/01	41,1	25,6	5,7	18,1	8	G1/8	14	10	10
RT-RF-8/02	48,8	28,7	8,3	18,1	8	G1/4	14	14	10
RT-RF-8/03	54,5	29,6	13,9	18,1	8	G3/8	14	19	10
RT-RF-10/02	48,8	32,3	8,3	20,4	10	G1/4	17	14	10
RT-RF-10/03	54,5	32,9	13,9	20,4	10	G3/8	17	19	10
RT-RF-10/04	60	35,9	11	20,4	10	G1/2	17	19	10
RT-RF-12/03	54,5	35,6	13,9	23,2	12	G3/8	20	19	10
RT-RF-12/04	60	36,6	11	23,2	12	G1/2	20	24	10

UNIDIRECTIONAL FLOW REGULATOR FOR VALVE (IN)



TYPE	L	A	B	C	ØD	G	ØP	CH	q.ty
RT-RFV-4/M5	28,2	21	5	12	4	M5	10	8	10
RT-RFV-6/M5	28,2	21	5	16	6	M5	13	8	10
RT-RFV-4/01	41,1	22,5	5,7	15,1	4	G1/8	10	10	10
RT-RFV-4/02	48,8	24,3	8,3	15,1	4	G1/4	10	14	10
RT-RFV-6/01	41,1	23,4	5,7	16	6	G1/8	12	10	10
RT-RFV-6/02	48,8	25,5	8,3	16	6	G1/4	12	14	10
RT-RFV-8/01	41,1	25,6	5,7	18,1	8	G1/8	14	10	10
RT-RFV-8/02	48,8	28,7	8,3	18,1	8	G1/4	14	14	10
RT-RFV-8/03	54,5	29,6	13,9	18,1	8	G3/8	14	19	10
RT-RFV-10/02	48,8	32,3	8,3	20,4	10	G1/4	17	14	10
RT-RFV-10/03	54,5	32,9	13,9	20,4	10	G3/8	17	19	10
RT-RFV-10/04	60	35,9	11	20,4	10	G1/2	17	19	10
RT-RFV-12/03	54,5	35,6	13,9	23,2	12	G3/8	20	19	10
RT-RFV-12/04	60	36,6	11	23,2	12	G1/2	20	24	10

TECHNICAL DATA

Material	Body and thrust ring: nickel plated brass			
Thread	Metric, taper and parallel			
Seal	NBR rubber			
Clamp	Stainless steel AISI 316			
Size	M5 ÷ 1/2			
Fluid	Air			
Working temperature	-20 ÷ +80 °C			
Max. pressure	Fittings: 16 bar - Flow regulators: 10 bar			
Permissible tolerances for tubes	Polyamide PA11 - PA12		Polyurethane PU	
	Outside tube Ø	Outside tube Ø tolerance	Outside tube Ø	Outside tube Ø tolerance
	4 ÷ 8 mm	±0,1 mm	4 ÷ 8 mm	±0,1 mm
	10 ÷ 14 mm	±0,1 mm	10 ÷ 14 mm	±0,15 mm

PARALLEL STRAIGHT MALE

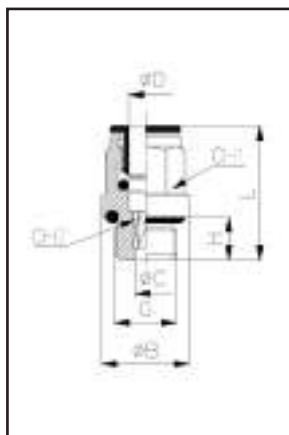

TYPE	L	ØB	ØC	ØD	G	H	CH1	CH2	q.ty
RO-DM - 4/M5	20,5	9	2,6	4	M5	4	-	2,5	50
RO-DM - 4/M6	20,5	9	2,6	4	M6	5	-	2,5	50
RO-DM - 4/M7	22,2	10,5	3,6	4	M7	6	9	3,5	50
RO-DM - 4/M8	23,5	12	2,6	4	M8	7	10	2,5	50
RO-DM - 4/01	20	13,5	2,6	4	G1/8	6	9	2,5	50
RO-DM - 4/02	21	17	2,6	4	G1/4	8	9	2,5	50
RO-DM - 6/M5	22,5	10,5	2,6	6	M5	4	-	2,5	50
RO-DM - 6/M6	21,5	11	2,5	6	M6	4	-	2,5	50
RO-DM - 6/M7	24	10,5	3,6	6	M7	6	-	3,5	50
RO-DM - 6/M12	24	16	4,2	6	M12X1,25	8	11	4	50
RO-DM - 6/M12A	24	16	4,2	6	M12X1,5	8	11	4	50
RO-DM - 6/01	24	13,5	4,2	6	G1/8	6	11	4	50
RO-DM - 6/02	24	17	4,2	6	G1/4	8	11	4	50
RO-DM - 6/03	24	20	4,2	6	G3/8	9	13	4	50
RO-DM - 8/01	26,5	13	5,2	8	G1/8	6	13	5	50
RO-DM - 8/02	25	17	6,2	8	G1/4	8	13	6	50
RO-DM - 8/03	25	20	6,2	8	G3/8	9	13	6	50
RO-DM - 8/04	31	23	6,2	8	G1/2	11	13	6	25
RO-DM - 10/01	28	13,5	5,2	10	G1/8	6	16	5	50
RO-DM - 10/02	29,5	16	7,3	10	G1/4	8	16	7	50
RO-DM - 10/03	29,5	21	8,3	10	G3/8	9	16	8	50
RO-DM - 10/04	30	24	8,3	10	G1/2	11	16	8	25
RO-DM - 12/02	31,5	16	7,3	12	G1/4	8	18	7	50
RO-DM - 12/03	31	21	10,3	12	G3/8	9	18	10	25
RO-DM - 12/04	31	24	10,3	12	G1/2	11	18	10	25
RO-DM - 14/03	34	21	10,3	14	G3/8	9	21	10	25
RO-DM - 14/04	34	25	12	14	G1/2	11	21	12	25

PARALLEL STRAIGHT FEMALE

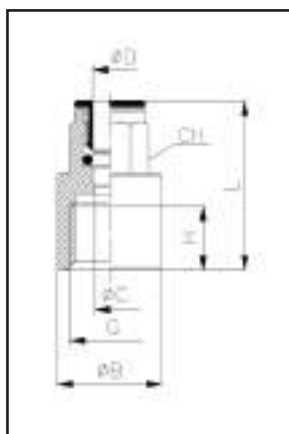

TYPE	L	ØB	ØC	ØD	G	H	CH	q.ty
RO-DF-4/M5	21,5	9	3	4	M5	5	9	50
RO-DF-4/01	26,5	12	3	4	G1/8	6,5	9	50
RO-DF-4/02	29,5	17	3	4	G1/4	10	9	50
RO-DF-6/01	27	12	5	6	G1/8	6,5	11	50
RO-DF-6/02	31	17	5	6	G1/4	10	11	50
RO-DF-8/01	28	12	7	8	G1/8	6,5	13	50
RO-DF-8/02	32	17	7	8	G1/4	10	13	50
RO-DF-10/02	32	16	9	10	G1/4	10	16	50
RO-DF-10/03	38	20	9	10	G3/8	13	20	25

PARALLEL SWIVEL MALE ELBOW

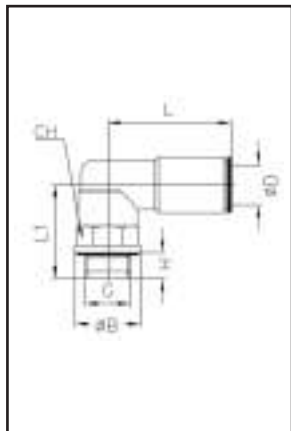

TYPE	L	L1	ØB	ØD	G	H	CH	q.ty
RO-GM-4/M5	17,5	20	8	4	M5	4	8	50
RO-GM-4/M6	-	-	-	4	M6	-	-	50
RO-GM-4/M7	21,5	18	10,5	4	M7	6	11	50
RO-GM-4/01	17,5	18,5	12,8	4	G1/8	5,8	13	50
RO-GM-4/02	19	22,5	12,8	4	G1/4	8	16	50
RO-GM-6/M5	21	14,5	8	6	M5	4	9	50
RO-GM-6/M6	19,5	15,5	9	6	M6	5	9	50
RO-GM-6/M7	19,5	16,5	10	6	M7	6	9	50
RO-GM-6/M12	19	25	16	6	M12x1,25	8	13	50
RO-GM-6/M12A	19	25	16	6	M12x1,50	8	13	50
RO-GM-6/01	21	20	13	6	G1/8	6	13	50
RO-GM-6/02	21	24	16	6	G1/4	8	13	50
RO-GM-6/03	21	25,5	20	6	G3/8	9	13	25
RO-GM-8/01	24	20	13	8	G1/8	6	13	50
RO-GM-8/02	24	24	16	8	G1/4	8	13	50
RO-GM-8/03	24	25,5	20	8	G3/8	9	13	50
RO-GM-10/02	27	24	16	10	G1/4	8	16	50
RO-GM-10/03	27	28	20	10	G3/8	9	16	50
RO-GM-10/04	27	30	25	10	G1/2	11	16	25
RO-GM-12/02	28	27,5	16	12	G1/4	8	16	50
RO-GM-12/03	28	28,5	20	12	G3/8	9	20	25
RO-GM-12/04	28	33,5	25	12	G1/2	11	20	25
RO-GM-14/03	31	28,5	20	14	G3/8	9	20	25
RO-GM-14/04	31	30,5	25	14	G1/2	11	21	25

5

TAPER FIXED MALE ELBOW

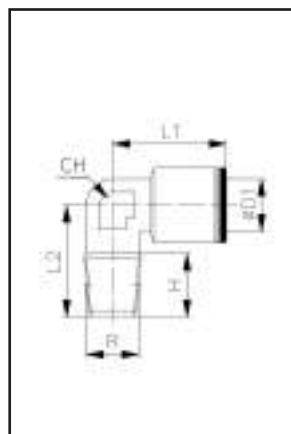

TYPE	L1	L2	ØD1	H	R	CH	q.ty
RO1-GM-4/01	18	16,5	4	8	R1/8	10	50
RO1-GM-5/01	18	16,5	5	9	R1/8	10	50
RO1-GM-6/01	22	22,5	6	8	R1/8	10	50
RO1-GM-6/02	23	18,5	6	11,5	R1/4	12	25
RO1-GM-8/01	24	22,5	8	9	R1/8	11	25
RO1-GM-8/02	24	22,5	8	11,5	R1/4	12	25
RO1-GM-10/02	24	22,5	10	11,5	R1/4	14	25

TAPER SWIVEL MALE ELBOW

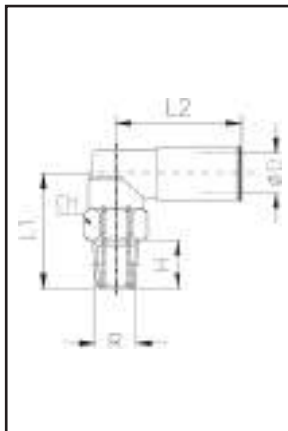

TYPE	L1	L2	ØD	H	R	CH	q.ty
RO1-GMG-4/01	20,2	19	4	7	R1/8	13	50
RO1-GMG-4/02	25	19	4	11	R1/4	14	50
RO1-GMG-6/01	20,2	21	6	7	R1/8	13	50
RO1-GMG-6/02	25	21	6	11	R1/4	14	50
RO1-GMG-8/01	20,2	24	8	7	R1/8	13	50
RO1-GMG-8/02	25	24	8	11	R1/4	14	50
RO1-GMG-8/03	28	24	8	11	R3/8	18	50
RO1-GMG-10/02	26	27	10	11	R1/4	16	50
RO1-GMG-10/03	30	27	10	11	R3/8	16	50
RO1-GMG-12/03	32,5	28	12	11	R3/8	20	50
RO1-GMG-12/04	35,5	28	12	14	R1/2	22	25
RO1-GMG-14/03	32,5	31	14	11	R3/8	20	25
RO1-GMG-14/04	35,5	31	14	14	R1/2	22	25

5

PARALLEL SWIVELLING CENTRAL MALE TEE

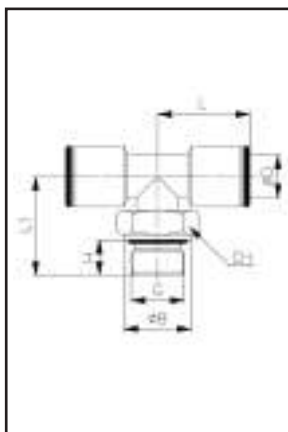

TYPE	L	L1	ØB	ØD	G	H	CH	q.ty
RO-TC-4/M5	17,5	16,5	8	4	M5	4	9	50
RO-TC-4/01	17,5	20	13	4	G1/8	6	13	50
RO-TC-4/02	19	24	16	4	G1/4	8	13	50
RO-TC-6/01	21	20	13	6	G1/8	6	13	50
RO-TC-6/02	21	24	16	6	G1/4	8	13	50
RO-TC-8/01	23	20	13	8	G1/8	6	13	50
RO-TC-8/02	23	24	16	8	G1/4	8	13	50
RO-TC-8/03	25,5	25,5	20	8	G3/8	9	13	50
RO-TC-10/02	25,5	28	16	10	G1/4	8	16	50
RO-TC-10/03	25,5	29	12	10	G3/8	9	16	50
RO-TC-12/02	27	30,5	16	12	G1/4	8	16	50
RO-TC-12/03	27	28,5	20	12	G3/8	9	20	25
RO-TC-14/04	31	33,5	25	14	G1/2	11	20	25

PARALLEL SWIVELLING LATERAL MALE TEE

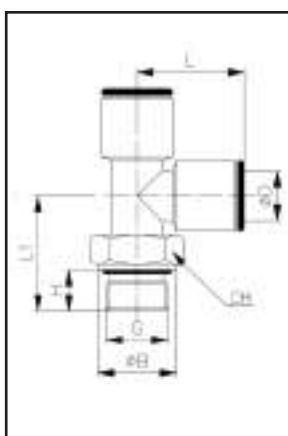

TYPE	L	L1	ØB	ØD	G	H	CH	q.ty
RO-TL-4/M5	17,5	16,5	8	4	M5	4	9	50
RO-TL-4/01	17,5	20	13	4	G1/8	6	13	50
RO-TL-4/02	19	24	13	4	G1/4	8	13	50
RO-TL-6/01	19,5	20	13	6	G1/8	6	13	50
RO-TL-6/02	21	24	16	6	G1/4	8	13	50
RO-TL-8/01	23	20	13	8	G1/8	6	13	50
RO-TL-8/02	23	24	16	8	G1/4	8	13	50
RO-TL-8/03	25,5	25,5	20	8	G3/8	9	13	50
RO-TL-10/02	25,5	24	16	10	G1/4	8	16	50
RO-TL-10/03	25,5	28	20	10	G3/8	9	16	50
RO-TL-12/02	27	30,5	16	12	G1/4	8	16	50
RO-TL-12/03	21	28,5	20	12	G3/8	9	20	25
RO-TL-14/04	31	33,5	25	14	G1/2	11	20	25

COMPLETE PARALLEL SINGLE BANJO, ROTATING 360°



TYPE	L	L1	ØA	ØD	G	H	CH	q.ty
RO-BSR-4/M5	18,5	17	2	4	M5	4	2	50
RO-BSR-4/01	21	25	5,5	4	G1/8	6	3	50
RO-BSR-6/01	23,5	25	5,5	6	G1/8	6	3	50
RO-BSR-8/01	24,5	25	5,5	8	G1/8	6	3	50
RO-BSR-6/02	24,5	29,3	7,8	6	G1/4	8	4	50
RO-BSR-8/02	26	29,3	7,8	8	G1/4	8	4	25
RO-BSR-10/02	27	29,3	7,8	10	G1/4	8	4	25
RO-BSR-8/03	29	34	10	8	G3/8	9	5	25
RO-BSR-10/03	29	34	10	10	G3/8	9	5	25
RO-BSR-12/02	29,3	28	7,8	12	G1/4	8	4	25
RO-BSR-12/03	29	34	10	12	G3/8	9	5	25

COMPLETE PARALLEL DOUBLE BANJO, ROTATING 360°



TYPE	L	L1	ØA	ØD	G	H	CH	q.ty
RO-BDR-4/M5	18,5	17	2	4	M5	4	2	50
RO-BDR-4/01	21	25	5,5	4	G1/8	6	3	50
RO-BDR-5/M5	19,5	17	2	5	M5	4	2	50
RO-BDR-5/01	22,5	25	5,5	5	G1/8	6	3	50
RO-BDR-6/01	23	25	5,5	6	G1/8	6	3	50
RO-BDR-8/01	24	25	5,5	8	G1/8	6	3	50
RO-BDR-6/02	24	29,3	7,8	6	G1/4	8	4	50
RO-BDR-8/02	26	29,3	7,8	8	G1/4	8	4	50
RO-BDR-10/02	27	29,3	7,8	10	G1/4	8	4	25
RO-BDR-8/03	28	34	10	8	10	9	5	25
RO-BDR-10/03	29	34	10	10	10	9	5	25
RO-BDR-12/03	30	34	10	12	10	9	5	25

5

COMPLETE PARALLEL TWO SINGLE BANJO, ROTATING 360°



TYPE	L1	L2	L3	L4	ØB	ØD	G	H	CH	q.ty
RO-2BSR-4/01	44	19	15	21	13	4	G1/8	6	14	25
RO-2BSR-6/01	44	19	15	23	13	6	G1/8	6	14	25
RO-2BSR-8/01	44	19	15	24	13	8	G1/8	6	14	25
RO-2BSR-6/02	50	22,5	17	24	17	6	G1/4	8	17	25
RO-2BSR-8/02	50	22,5	17	26	17	8	G1/4	8	17	10
RO-2BSR-10/02	50	22,5	17	27	17	10	G1/4	8	17	10
RO-2BSR-12/02	50	22,5	17	28	17	12	G1/4	8	17	10

COMPLETE PARALLEL THREE SINGLE BANJO, ROTATING 360°



TYPE	L1	L2	L3	L4	ØB	ØD	G	H	CH	q.ty
RO-3BSR-4/01	59	19	15	21	13	4	G1/8	6	14	25
RO-3BSR-6/01	59	19	15	23	13	6	G1/8	6	14	25
RO-3BSR-8/01	59	19	15	24	13	8	G1/8	6	14	25
RO-3BSR-6/02	67	21,5	17	24	17	6	G1/4	8	17	25
RO-3BSR-8/02	67	21,5	17	26	17	8	G1/4	8	17	10
RO-3BSR-10/02	67	21,5	17	27	17	10	G1/4	8	17	10
RO-3BSR-12/02	67	21,5	17	28	17	12	G1/4	8	17	10

COMPLETE PARALLEL SINGLE SWIVEL BANJO

5



TYPE	L	L1	ØB	ØD	G	H	CH	q.ty
RO-BS-4/M5	18,5	17,5	7	4	M5	4,5	8	50
RO-BS-4/M6	21	18	14	4	M6	4,5	9	50
RO-BS-4/01	21	28	14	4	G1/8	7,5	14	50
RO-BS-6/M5	19	17,5	10	6	M5	4,5	8	50
RO-BS-6/01	22,5	28	14	6	G1/8	7,5	14	50
RO-BS-6/02	24	33	18	6	G1/4	9	17	50
RO-BS-8/01	24,5	28	14	8	G1/8	7,5	14	25
RO-BS-8/02	26	33	18	8	G1/4	9	17	25
RO-BS-8/03	28	37	21	8	G3/8	10	22	25
RO-BS-10/02	27	33	18	10	G1/4	9	17	25
RO-BS-10/03	29	37	21	10	G3/8	10	22	25
RO-BS-12/02	28	33	18	12	G1/4	9	17	25
RO-BS-12/03	30	37	21	12	G3/8	10	22	10

COMPLETE PARALLEL DOUBLE SWIVEL BANJO



TYPE	L	L1	ØB	ØD	G	H	CH	q.ty
RO-BD-4/M5	18,5	17,5	7	4	M5	4,5	8	50
RO-BD-4/01	21	28	14	4	G1/8	7,5	14	50
RO-BD-6/01	22,5	28	14	6	G1/8	7,5	14	50
RO-BD-6/02	24	33	18	6	G1/4	9	17	50
RO-BD-8/01	24,5	28	14	8	G1/8	7,5	14	25
RO-BD-8/02	26	33	18	8	G1/4	9	17	25
RO-BD-8/03	28	37	21	8	G3/8	10	22	25
RO-BD-10/02	27	33	18	10	G1/4	9	17	25
RO-BD-10/03	29	37	21	10	G3/8	9	22	25
RO-BD-12/03	30	37	21	12	G3/8	9	22	10

UNION STRAIGHT

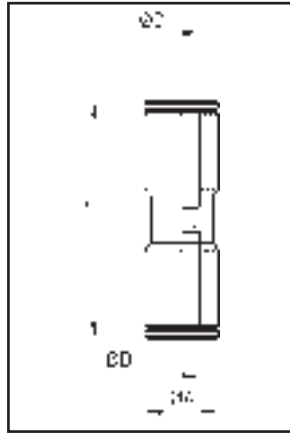

TYPE	L	ØA	ØD	q.ty
RO-DI-4	30	9	4	50
RO-DI-6	31,5	11	6	50
RO-DI-8	36	13	8	50
RO-DI-10	37	15	10	50
RO-DI-12	40,5	17	12	50
RO-DI-14	45	20	14	50

REDUCED UNION STRAIGHT

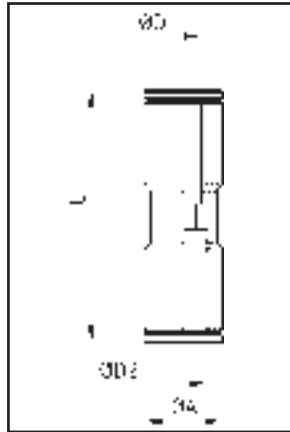

TYPE	L	ØA	ØD	ØD2	q.ty
RO-DIR-6/4	33,5	11	4	6	50
RO-DIR-8/6	37	13	6	8	50
RO-DIR-10/8	39,5	16	8	10	50
RO-DIR-12/10	40	20	10	12	50
RO-DIR-14/12	43	22	12	14	50

5

UNION ELBOW



TYPE	L	ØB	ØC	ØD	q.ty
RO-GI-4	17,5	9	3	4	50
RO-GI-6	19,5	11	5	6	50
RO-GI-8	23	13	7	8	50
RO-GI-10	25	15	8	10	50
RO-GI-12	27	17	10	12	25
RO-GI-14	30	20	12	14	25

UNION TEE



TYPE	L	ØB	ØC	ØD1	ØD2	q.ty
RO-TI-4	17,5	9	3	4	4	50
RO-TI-6	19,5	11	5	6	6	50
RO-TI-6/4	19,5	11	3	6	4	50
RO-TI-8	23	13	7	8	8	50
RO-TI-8/6	23	13	5	8	6	50
RO-TI-10	25	15	8	10	10	20
RO-TI-10/8	25	15	7	10	8	20
RO-TI-12	27	17	10	12	12	20
RO-TI-14	30	20	12	14	14	20

BULKHEAD CONNECTOR

5

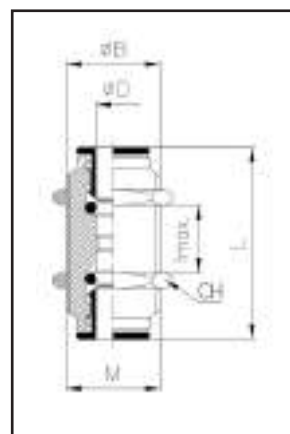

TYPE	L	ØB	ØD	lmax	M	CH	q.ty
RO-P-4	32	10	4	8	M10x1	13	50
RO-P-6	33,5	14	6	8	M14x1	17	50
RO-P-8	37	16	8	10	M16x1	18	50
RO-P-10	39,5	17	10	12	M17x1	20	25
RO-P-12	42	20	12	17	M20x1	24	25
RO-P-14	45	22	14	18	M22x1	25	25

FEMALE BULKHEAD CONNECTOR

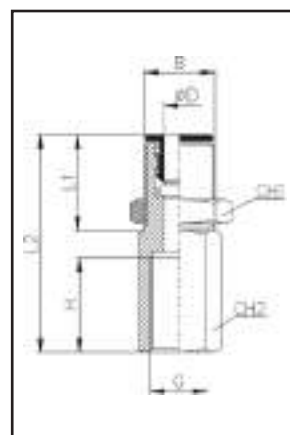

TYPE	L1	L2	B	ØD	G	H	CH1	CH2	q.ty
RO-PF-4/01	13	25	M10x1	4	G1/8	6,5	13	15	50
RO-PF-6/01	13	27	M14x1	6	G1/8	6,5	17	17	50
RO-PF-6/02	13	21	M14x1	6	G1/4	10,5	17	17	50
RO-PF-8/01	13	28	M13x1	8	G1/8	6,5	19	17	50
RO-PF-8/02	13	33	M13x1	8	G1/4	10,5	19	17	50

REDUCER

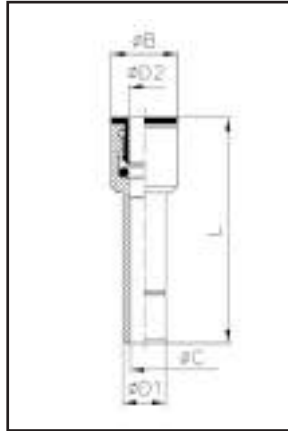

TYPE	L	$\varnothing B$	$\varnothing C$	$\varnothing D1$	$\varnothing D2$	q.ty
RO-R-6/4	28,5	9	3	6	4	50
RO-R-6/5	35,5	9,5	4	6	5	50
RO-R-8/4	31	9	3	8	4	50
RO-R-8/5	32,5	9,5	4	8	5	50
RO-R-8/6	33,5	10,5	5	8	6	50
RO-R-10/6	36,5	10,5	5	10	6	50
RO-R-10/8	38	13	7	10	8	50
RO-R-12/4	39,5	13	3	12	4	25
RO-R-12/6	39,5	13	5	12	6	25
RO-R-12/8	38,5	13	7	12	8	25
RO-R-12/10	41	15	9	12	10	25
RO-R-14/4	43	15	3	14	4	25
RO-R-14/6	43	15	5	14	6	25
RO-R-14/8	43	15	7	14	8	25
RO-R-14/10	43	15	9	14	10	25
RO-R-14/12	43	17	11	14	12	25

INCREASER

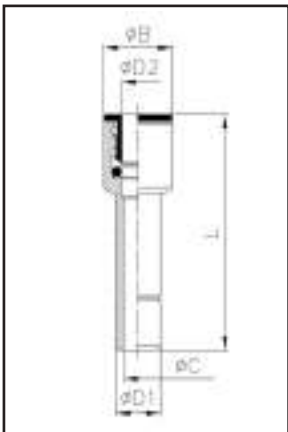

TYPE	L	$\varnothing B$	$\varnothing C$	$\varnothing D1$	$\varnothing D2$	q.ty
RO-E-4/6	33,5	10,5	2	4	6	25
RO-E-6/8	38	13	4	6	8	25

5

PLUG

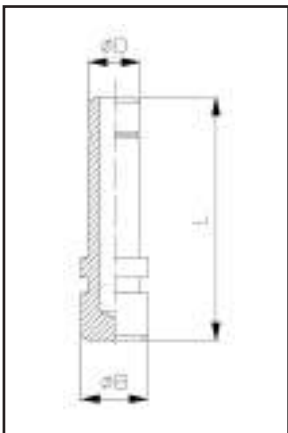

TYPE	L	$\varnothing B$	$\varnothing D$	q.ty
RO-T-4	25,5	5	4	50
RO-T-6	27,5	7	6	50
RO-T-8	30	9	8	50
RO-T-10	35	11	10	25
RO-T-12	37	13	12	25
RO-T-14	39,5	15	14	25

UNION CONNECTOR

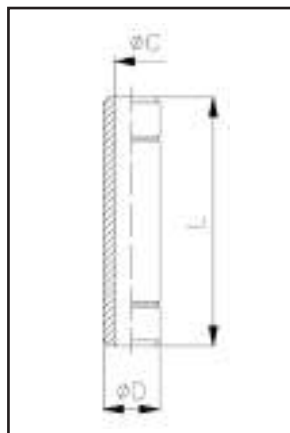

TYPE	L	ØC	ØD	q.ty
RO-CI-4	32	2	4	50
RO-CI-6	35	4	6	50
RO-CI-8	38	6	8	50
RO-CI-10	45,5	8	10	50
RO-CI-12	48	10	12	25
RO-CI-14	52	12	14	20

PARALLEL LONG ADAPTER

5

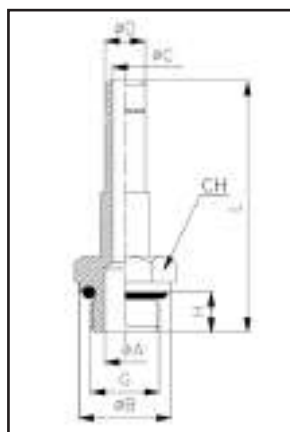

TYPE	L	ØA	ØB	ØC	ØD	G	H	CH	q.ty
RO-ACL-4/M7	38	4	-	2	4	M7	6	10	50
RO-ACL-4/01	39,2	6	13	2	4	G1/8	6	13	50
RO-ACL-6/M7	42	4	-	4	6	M7	6	10	50
RO-ACL-6/01	43,5	6	13	4	6	G1/8	6	13	50
RO-ACL-6/02	46	7,5	16	4	6	G1/4	8	14	50
RO-ACL-8/01	46,7	6	13	6	8	G1/8	6	13	50
RO-ACL-8/02	49,7	7,5	16	6	8	G1/4	8	14	50
RO-ACL-10/02	55,5	8	16	8	10	G1/4	8	14	50

P.S.: THIS ADAPTER CAN BE USED EVEN WITH THE UNION FITTINGS OF SERIES "RT"

PARALLEL ADAPTER

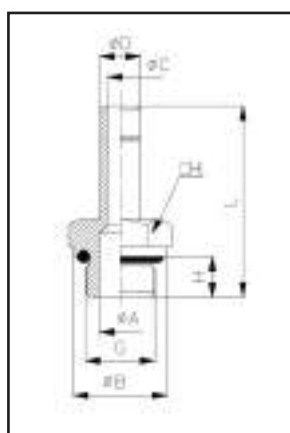

TYPE	L	ØA	ØB	ØC	ØD	G	H	CH	q.ty
RO-AC-4/M5	24,5	2	8	2	4	M5	4	8	50
RO-AC-4/M7	26	4	-	2	4	M7	6	10	50
RO-AC-4/01	27,7	6	13	2	4	G1/8	6	13	50
RO-AC-4/02	30,2	7,5	16	2	4	G1/4	8	13	50
RO-AC-6/M5	26	2,6	8	2,6	6	M5	4	8	50
RO-AC-6/M7	28	4	-	4	6	M7	6	10	50
RO-AC-6/01	29,5	6	13	4	6	G1/8	6	13	50
RO-AC-6/02	32	7,5	16	4	6	G1/4	8	13	50
RO-AC-8/01	31	6	13	6	8	G1/8	6	13	50
RO-AC-8/02	33,5	7,5	16	6	8	G1/4	8	13	50
RO-AC-8/03	35,5	9	20	6	8	G3/8	9	13	50
RO-AC-10/01	35,5	6	-	8	10	G1/8	6	13	50
RO-AC-10/02	38	8	16	8	10	G1/4	8	13	50
RO-AC-10/03	41	8	20	8	10	G3/8	9	13	50
RO-AC-12/02	39	10	16	10	12	G1/4	8	13	50
RO-AC-12/03	42	11	20	10	12	G3/8	9	13	25
RO-AC-12/04	44	13	24	10	12	G1/2	11	16	25
RO-AC-14/03	44	12	20	12	14	G3/8	9	16	25
RO-AC-14/04	46	13	24	12	14	G1/2	11	16	25

P.S.: THIS ADAPTER CAN BE USED EVEN WITH THE UNION FITTINGS OF SERIES "RT"

TUBE CONNECTOR

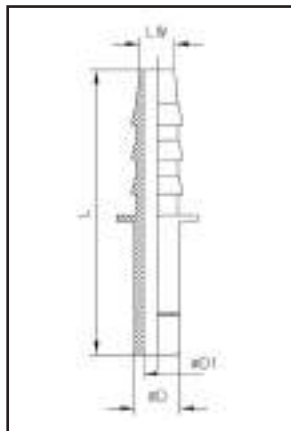

TYPE	L	ØD	ØD1	LW	q.ty
RO-CT-6/4	36,5	6	4	6	25
RO-CT-8/6	38	8	6	6	25
RO-CTL-8/6	43	8	6	8	25
RO-CT-12/10	57	12	10	13	25
RO-CT-14/11	60	14	11	14	25

SINGLE BANJO BODY

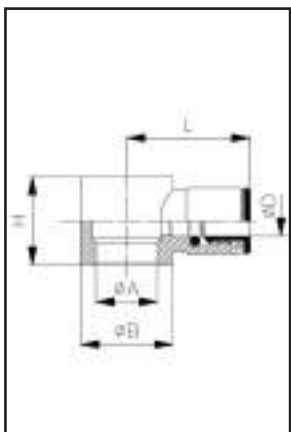

TYPE	L	ØA	ØB	ØD	-	H	q.ty
RO-CBS-4/M5	19	5	9	4	M5	9	50
RO-CBS-4/M6	19	6	9	4	M6	9	50
RO-CBS-4/01	21	9,9	14	4	G1/8	15	50
RO-CBS-6/M5	19	5,1	10	6	M5	10,5	50
RO-CBS-6/01	23	9,9	14	6	G1/8	15	50
RO-CBS-6/02	24	13,3	18	6	G1/4	17	50
RO-CBS-8/01	24,5	9,9	14	8	G1/8	15	50
RO-CBS-8/02	26	13,3	18	8	G1/4	17	50
RO-CBS-8/03	28	16,6	21	8	G3/8	20	50
RO-CBS-10/02	27	13,3	18	10	G1/4	17	50
RO-CBS-10/03	29	16,6	21	10	G3/8	20	25
RO-CBS-12/02	28	13,6	18	12	G1/4	17	25
RO-CBS-12/03	30	16,6	21	12	G3/8	20	25

5

DOUBLE BANJO BODY



TYPE	L	ØA	ØB	ØD	-	H	q.ty
RO-CBD-4/M5	18,5	5	7	4	M5	9	50
RO-CBD-4/01	21	9,9	14	4	G1/8	15	50
RO-CBD-6/01	23	9,9	14	6	G1/8	15	50
RO-CBD-6/02	24	13,3	18	6	G1/4	17	50
RO-CBD-8/01	24,5	9,9	14	8	G1/8	15	50
RO-CBD-8/02	26	13,3	18	8	G1/4	17	50
RO-CBD-8/03	28	16,6	21	8	G3/8	20	50
RO-CBD-10/02	27	13,3	18	10	G1/4	17	50
RO-CBD-10/03	29	16,6	21	10	G3/8	20	25
RO-CBD-12/03	30	16,6	21	12	G3/8	20	25

SINGLE BANJO STEM

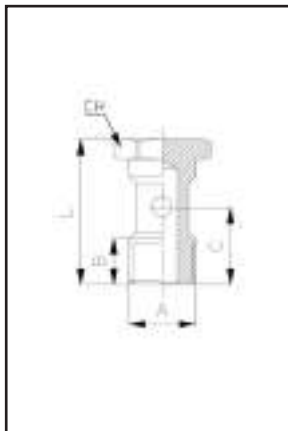

TYPE	L	A	B	C	CH	q.ty
RO-VBS-M5	17,5	M5	7,6	9,6	8	50
RO-VBS-M6	19	M6	7,5	10,8	8	50
RO-VBS-01	28	G1/8	9	15	14	50
RO-VBS-02	33	G1/4	13	18	17	50
RO-VBS-03	37	G3/8	12	21,5	22	50
RO-VBS-04	42	G1/2	14,5	23,5	27	25

DOUBLE BANJO STEM

5

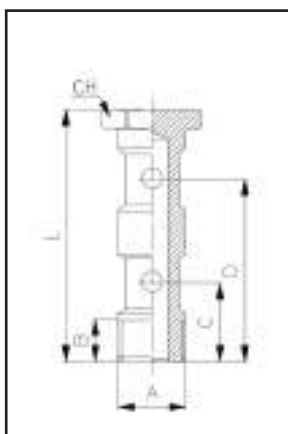

TYPE	L	A	B	C	D	CH	q.ty
RO-VBD-01	44,5	G1/8	9	15	31	14	25
RO-VBD-02	51,5	G1/4	11	17	36	17	25
RO-VBD-03	58,6	G3/8	12	20,5	42	19	25
RO-VBD-04	68	G1/2	13	23,5	49,5	27	25

WASHER

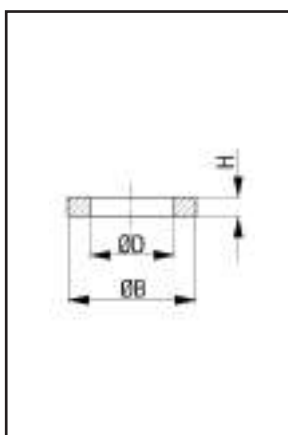

TYPE	ØB	ØD	H	-	q.ty
RO-RD-M5	7,7	5,3	1	M5	100
RO-RD-01	13	10,2	1,5	G1/8	100
RO-RD-02	17,9	13,4	2	G1/4	100
RO-RD-03	21,8	17,1	2	G3/8	100
RO-RD-04	26,5	21,3	2	G1/2	100
RO-RD-06	32,4	26,7	2	G3/4	100

For banjo stem type RC-VBS, RO-VBS and RO-VBD, order No. 2 spacers type RO-RD, to be fitted as follow: one under the head of the screw, and one under the last banjo.

Spacer for RO-VB and RC-VBD*					
TYPE	ØB	ØD	H	-	q.ty
RO-DIS-01	14	10,2	5	G1/8	50
RO-DIS-02	17,5	13,2	5	G1/4	50

* To be fitted between the two rings.

PARALLEL UNIDIRECTIONAL FLOW REGULATOR (SCREWDRIVER) FOR CYLINDER (OUT)

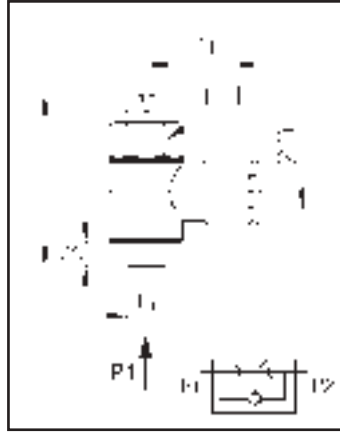

TYPE	L	B	D	ØD	G	CH	NI/min*	q.ty
RO-RC-4/M5	24,5	6	17	4	M5	8	45	50
RO-RC-4/01	31,5	5,5	21	4	G1/8	14	310	50
RO-RC-6/M5	24,5	4	21	6	M5	8	45	50
RO-RC-6/01	31,5	5,5	22,5	6	G1/8	14	390	50
RO-RC-6/02	38	6	24	6	G1/4	17	710	50
RO-RC-8/01	31,5	5,5	24,5	8	G1/8	14	390	25
RO-RC-8/02	38	6	26	8	G1/4	17	810	25
RO-RC-8/03	40	6	28	8	G3/8	20	1050	25
RO-RC-10/02	38	6	28	10	G1/4	17	810	25
RO-RC-10/03	47	6	29	10	G3/8	20	1050	25
RO-RC-12/02	38	6	28	12	G1/4	17	810	25
RO-RC-12/03	47	6	30	12	G3/8	20	1050	10

* Nominal flow rate at 6 bar

PARALLEL UNIDIRECTIONAL FLOW REGULATOR (SCREWDRIVER) FOR VALVE (IN)

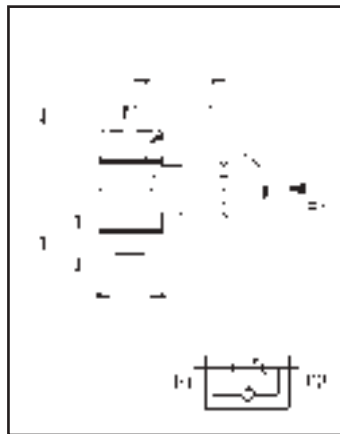

TYPE	L	B	D	ØD	G	CH	NI/min*	q.ty
RO-RV-4/M5	24,5	6	17	4	M5	8	45	50
RO-RV-4/01	31,5	5,5	21	4	G1/8	14	310	50
RO-RV-6/M5	24,5	4	21	6	M5	8	45	50
RO-RV-6/01	31,5	5,5	22,5	6	G1/8	14	390	50
RO-RV-6/02	38	6	24	6	G1/4	17	710	50
RO-RV-8/01	31,5	5,5	24,5	8	G1/8	14	390	25
RO-RV-8/02	38	6	26	8	G1/4	17	810	25
RO-RV-8/03	40	6	28	8	G3/8	20	1050	25
RO-RV-10/02	38	6	28	10	G1/4	17	810	25
RO-RV-10/03	47	6	29	10	G3/8	20	1050	25
RO-RV-12/02	38	6	28	12	G1/4	17	810	25
RO-RV-12/03	47	6	30	12	G3/8	20	1050	10

* Nominal flow rate at 6 bar

PARALLEL UNIDIRECTIONAL FLOW REGULATOR (HANDWHEEL) FOR CYLINDER (OUT)

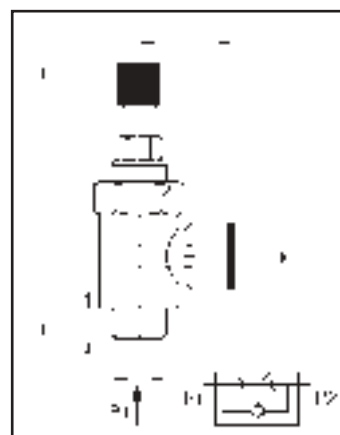

TYPE	L	B	C	ØD	G	NI/min*	CH	q.ty
RO-RF-4/01	49	5,5	17	4	G1/8	310	14	50
RO-RF-6/01	49	5,5	21	6	G1/8	390	14	50
RO-RF-8/01	49	5,5	22,5	8	G1/8	390	14	50
RO-RF-6/02	56,5	6	22,5	6	G1/4	710	17	25
RO-RF-8/02	56,5	6	24	8	G1/4	810	17	25
RO-RF-10/02	56,5	6	24,5	10	G1/4	810	17	25
RO-RF-12/02	56,5	6	26	12	G1/4	810	17	25

* Nominal flow rate at 6 bar

PARALLEL UNIDIRECTIONAL FLOW REGULATOR (HANDWHEEL) FOR VALVE (IN)

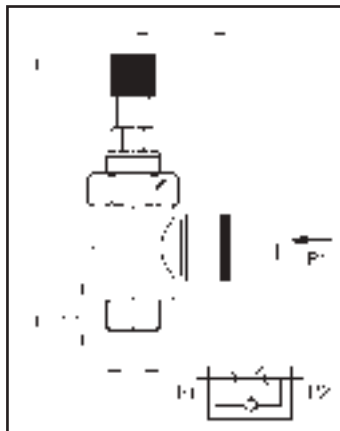

TYPE	L	B	C	ØD	G	NI/min*	CH	q.ty
RO-RFV-4/01	49	5,5	17	4	G1/8	310	14	50
RO-RFV-6/01	49	5,5	21	6	G1/8	390	14	50
RO-RFV-8/01	49	5,5	22,5	8	G1/8	390	14	50
RO-RFV-6/02	56,5	6	22,5	6	G1/4	710	17	25
RO-RFV-8/02	56,5	6	24	8	G1/4	810	17	25
RO-RFV-10/02	56,5	6	24,5	10	G1/4	810	17	25
RO-RFV-12/02	56,5	6	26	12	G1/4	810	17	25

* Nominal flow rate at 6 bar

TECHNICAL DATA

Material	Nickel plated brass
Thread	Metric, taper and parallel
Size	M5 ÷ 1
Fluid	Air
Max. temperature	150 °C
Max. pressure	60 bar

PARALLEL NIPPLE

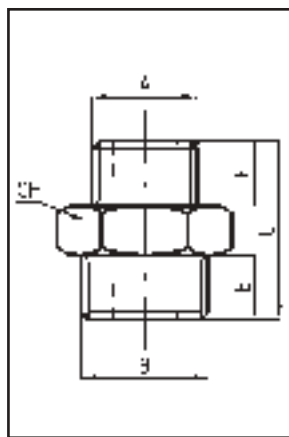

TYPE	L	A	B	E	F	CH	q.ty
RS-N-M5	11,5	M5	M5	4	4	8	50
RS-N-M5/01	14,5	M5	G1/8	6	4	14	50
RS-N-01	16,5	G1/8	G1/8	6	6	14	50
RS-N-01/02	19	G1/8	G1/4	8	6	17	50
RS-N-01/03	20	G1/8	G3/8	9	6	19	50
RS-N-02	21	G1/4	G1/4	8	8	17	50
RS-N-02/03	22	G1/4	G3/8	9	8	19	50
RS-N-02/04	23,5	G1/4	G1/2	10	8	24	50
RS-N-03	23	G3/8	G3/8	9	9	19	50
RS-N-03/04	24,5	G3/8	G1/2	10	9	24	50
RS-N-04	25,5	G1/2	G1/2	10	10	24	25
RS-N-04/06	27,5	G1/2	G3/4	11	10	30	25
RS-N-06	28,5	G3/4	G3/4	11	11	30	20
RS-N-06/08	32	G3/4	G1	23	15	22	20

5

TAPER NIPPLE

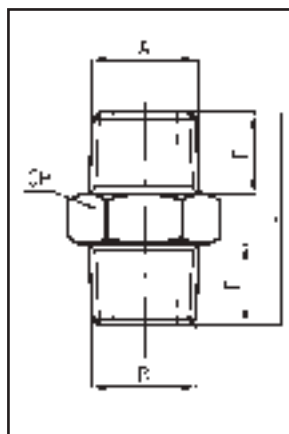

TYPE	L	A	B	E	F	CH	q.ty
RS1-N-01	20,5	R1/8	R1/8	8	8	12	50
RS1-N-01/02	24	R1/8	R1/4	11	8	14	50
RS1-N-01/03	24,5	R1/8	R3/8	11,5	8	17	50
RS1-N-02	27	R1/4	R1/4	11	11	14	50
RS1-N-02/03	27,5	R1/4	R3/8	11,5	11	17	50
RS1-N-02/04	30,5	R1/4	R1/2	14	11	22	50
RS1-N-03	28	R3/8	R3/8	11,5	11,5	17	50
RS1-N-03/04	31	R3/8	R1/2	14	11,5	22	50
RS1-N-04	33,5	R1/2	R1/2	14	14	22	50
RS1-N-04/06	37	R1/2	R3/4	16,5	14	27	25
RS1-N-06	39,5	R3/4	R3/4	16,5	16,5	27	20
RS1-N-06/08	42,5	R3/4	R1	19	16,5	34	10
RS1-N-08	45,5	R1	R1	19,0	19	34	10

SLEEVE

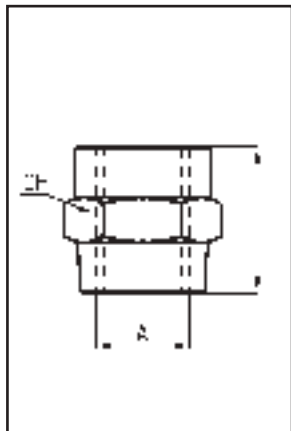

TYPE	L	A	CH	q.ty
RS-M-M5	11	M5	8	50
RS-M-01	15	G1/8	14	50
RS-M-02	22	G1/4	17	50
RS-M-03	23	G3/8	22	50
RS-M-04	28	G1/2	26	25
RS-M-06	32	G3/4	32	20

TAPER REDUCER

5

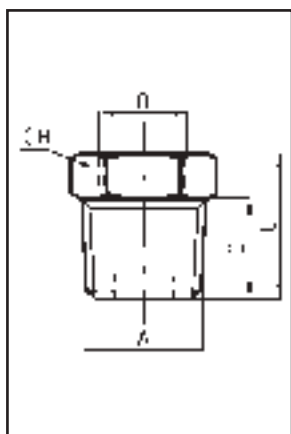

TYPE	L	A	B	C	CH	q.ty
RS1-RMF-02/01	16	R1/4	R1/8	11	14	50
RS1-RMF-03/01	16,5	R3/8	R1/8	11,5	17	50
RS1-RMF-04/01	19,5	R1/2	R1/8	14	22	25
RS1-RMF-03/02	16,5	R3/8	R1/4	11,5	17	50
RS1-RMF-04/02	19,5	R1/2	R1/4	14	22	50
RS1-RMF-04/03	19,5	R1/2	R3/8	14	22	50
RS1-RMF-06/04	23	R3/4	R1/2	16,5	27	20
RS1-RMF-06/03	23,5	R3/4	R3/8	16,5	27	20

PARALLEL REDUCER

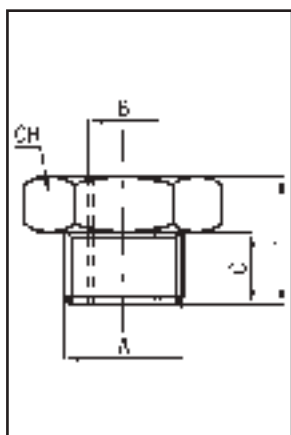

TYPE	L	A	B	C	CH	q.ty
RS-RMF-01/M5	10,5	G1/8	M5	6	14	50
RS-RMF-02/01	13	G1/4	G1/8	8	17	50
RS-RMF-03/01	14	G3/8	G1/8	9	19	50
RS-RMF-03/02	14	G3/8	G1/4	9	19	50
RS-RMF-04/01	15,5	G1/2	G1/8	10	24	25
RS-RMF-04/02	15,5	G1/2	G1/4	10	24	50
RS-RMF-04/03	15,5	G1/2	G3/8	10	24	50
RS-RMF-06/03	17,5	G3/4	G3/8	11	30	25
RS-RMF-06/04	17,5	G3/4	G1/2	11	30	20

TAPER MALE/FEMALE EXTENSION

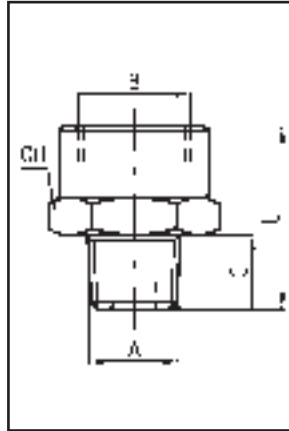

TYPE	L	A	B	C	CH	q.ty
RS1-PMF-01	18	R1/8	G1/8	8	14	50
RS1-PMF-01/02	21,5	R1/8	G1/4	8	17	50
RS1-PMF-01/03	22,5	R1/8	G3/8	8	22	50
RS1-PMF-02	24,5	R1/4	G1/4	11	17	50
RS1-PMF-02/03	25,5	R1/4	G3/8	11	22	50
RS1-PMF-02/04	29	R1/4	G1/2	11	24	50
RS1-PMF-03	26	R3/8	G3/8	11,5	22	50
RS1-PMF-03/04	29,5	R3/8	G1/2	11,5	24	50
RS1-PMF-04	32	R1/2	G1/2	14	26	25
RS1-PMF-04/06	35	R1/2	G3/4	14	32	20

PARALLEL MALE/FEMALE EXTENSION

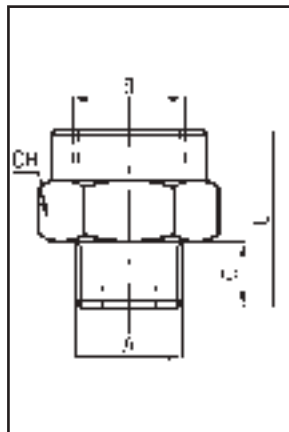

TYPE	L	A	B	C	CH	q.ty
RS-PMF-M5/01	14,5	M5	G1/8	4	14	50
RS-PMF-01	16	G1/8	G1/8	6	14	50
RS-PMF-01/02	19,5	G1/8	G1/4	6	17	50
RS-PMF-01/03	20,5	G1/8	G3/8	6	22	50
RS-PMF-02	21,5	G1/4	G1/4	8	17	50
RS-PMF-02/03	22,5	G1/4	G3/8	8	22	50
RS-PMF-02/04	26	G1/4	G1/2	8	24	50
RS-PMF-03	23,5	G3/8	G3/8	9	22	50
RS-PMF-03/04	27	G3/8	G1/2	9	24	50
RS-PMF-04	28	G1/2	G1/2	10	26	25

5

PARALLEL MALE/FEMALE LONG EXTENSION

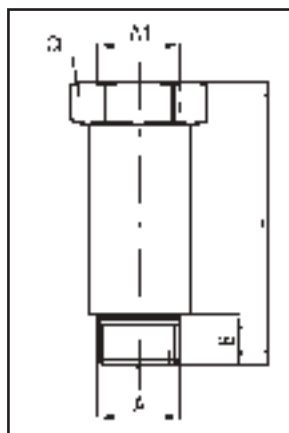

TYPE	L	A	A1	B	CH	q.ty
RS-PL-01A	22	G1/8	G1/8	6	14	50
RS-PL-01B	42	G1/8	G1/8	6	14	50
RS-PL-01C	51	G1/8	G1/8	6	14	50
RS-PL-02A	35	G1/4	G1/4	8	17	50
RS-PL-02B	51	G1/4	G1/4	8	17	50

REDUCING SLEEVE

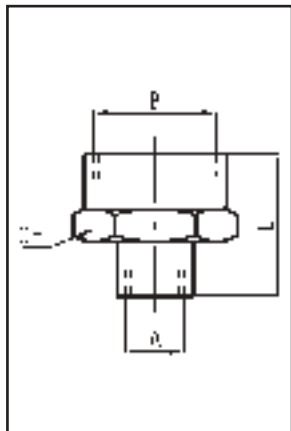

TYPE	L	A	B	CH	q.ty
RS-MR-M5/01	13,5	M5	G1/8	14	50
RS-MR-01/02	19	G1/8	G1/4	17	50
RS-MR-01/03	20	G1/8	G3/8	22	50
RS-MR-01/04	24	G1/8	G1/2	24	50
RS-MR-02/03	22,5	G1/4	G3/8	22	50
RS-MR-02/04	26	G1/4	G1/2	24	50
RS-MR-03/04	26	G3/8	G1/2	24	50
RS-MR-04/06	30	G1/2	G3/4	32	25

PARALLEL MALE PLUG

5

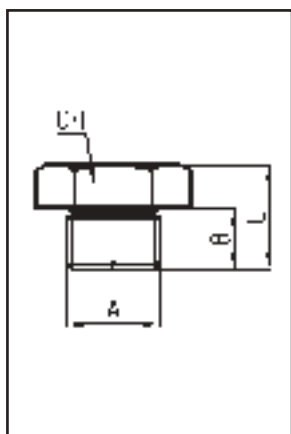

TYPE	L	A	B	CH	q.ty
RS-TC-M5	7	M5	4	8	50
RS-TC-01	10	G1/8	6,5	14	50
RS-TC-02	12,5	G1/4	8	17	50
RS-TC-03	13,5	G3/8	9	19	50
RS-TC-04	15,5	G1/2	10	24	50
RS-TC-06	16,5	G3/4	11	30	25
RS-TC-08	19	G1	13	38	10

PARALLEL MALE PLUG WITH O-RING

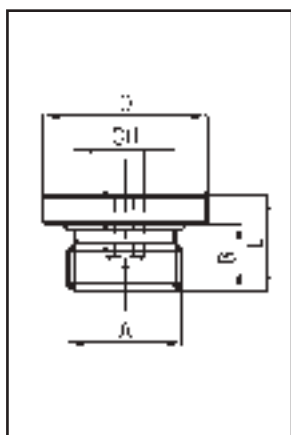

TYPE	L	A	B	ØD	CH	q.ty
RS-TMO-M5	7,2	M5	4,5	8	2,5	50
RS-TMO-01	9,5	G1/8	6,5	14	5	50
RS-TMO-02	11,5	G1/4	8	17	6	50
RS-TMO-03	12,5	G3/8	9	20	8	50
RS-TMO-04	14	G1/2	10	26	10	25

FEMALE PLUG

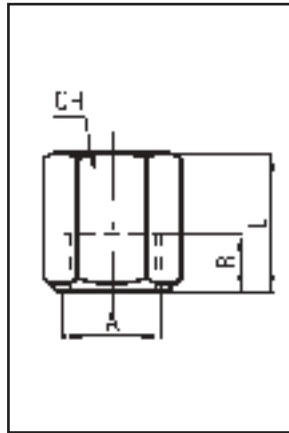

TYPE	L	A	B	CH	q.ty
RS-TFE-01	11,5	G1/8	8	14	50
RS-TFE-02	15	G1/4	11	17	50
RS-TFE-03	15,5	G3/8	11,5	20	50
RS-TFE-04	20	G1/2	14	24	25

FEMALE ELBOW

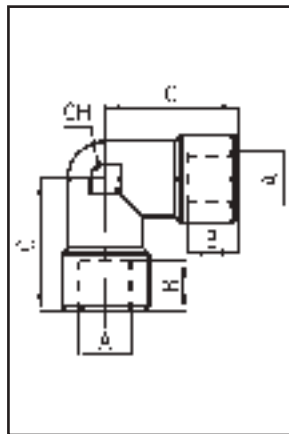

TYPE	A	B	C	CH	q.ty
RS-GF-M5	M5	4	11	8	50
RS-GF-01	G1/8	8	21	10	50
RS-GF-02	G1/4	11	25,5	13	50
RS-GF-03	G3/8	11,5	28	17	50
RS-GF-04	G1/2	14	33,5	21	25
RS-GF-06	G3/4	16,5	36,5	25	20
RS-GF-08	G1	19	45	30	10

5

TAPER MALE/FEMALE ELBOW

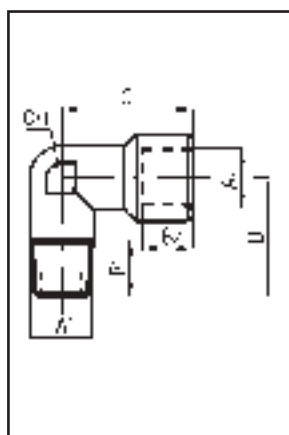

TYPE	A1	A2	B1	B2	C	CH	D	q.ty
RS-GMF-M5	M5	M5	4	5	11,5	9	11	50
RS-GMF-02/01	R1/4	G1/8	11	8	21,5	10	21	50
RS-GMF-01	R1/8	G1/8	8	8	18,5	10	21	50
RS-GMF-02	R1/4	G1/4	11	11	23,5	13	25,5	50
RS-GMF-03	R3/8	G3/8	11,5	11,5	26	17	28	50
RS-GMF-04	R1/2	G1/2	14	14	31	21	33,5	25
RS-GMF-06	R3/4	G3/4	16	16,5	33	25	36,5	20
RS-GMF-08	R1	G1	19	19	39	30	45	10

TAPER MALE ELBOW

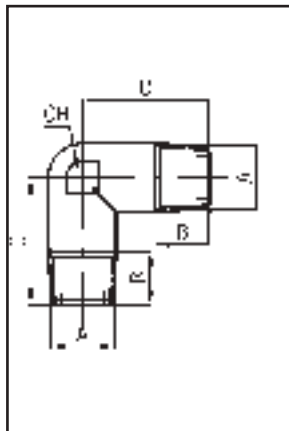

TYPE	A	B1	C	D	CH	q.ty
RS-GM-M5	M5	4	11,5	11,5	8	50
RS-GM-01	R1/8	8	18,5	18,5	10	50
RS-GM-02/01	R1/4	11	21,5	19	10	25
RS-GM-02	R1/4	11	23,5	23,5	13	50
RS-GM-03	R3/8	11,5	26	26	17	50
RS-GM-04	R1/2	14	31	31	21	25
RS-GM-06	R3/4	16	33	33	25	20
RS-GM-08	R1	17	39	39	30	10

FEMALE TEE

5

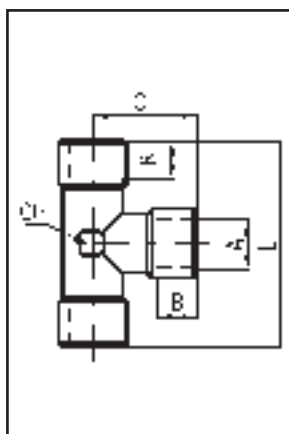

TYPE	L	A	B	C	CH	q.ty
RS-TF-M5	22	M5	5	11	9	50
RS-TF-01	42	G1/8	8	21	10	50
RS-TF-02	51	G1/4	11	25,5	13	50
RS-TF-03	56	G3/8	11,5	28	17	50
RS-TF-04	67	G1/2	14	33,5	21	25
RS-TF-06	73	G3/4	16,5	36,5	25	20
RS-TF-08	90	G1	19	45	30	10

TAPER UNION MALE TEE

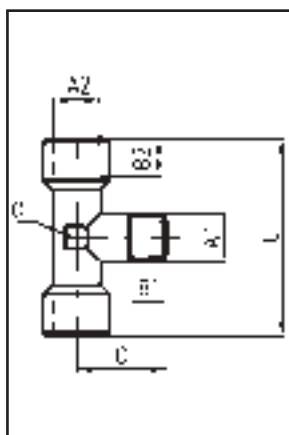

TYPE	L	A1	A2	B1	B2	C	CH	q.ty
RS-TMC-M5	22	M5	M5	4	5	11,5	9	50
RS-TMC-01	42	R1/8	G1/8	8	8	18,5	10	50
RS-TMC-02	51	R1/4	G1/4	11	11	23,5	13	50
RS-TMC-03	56	R3/8	G3/8	11,5	11,5	26	17	50
RS-TMC-04	67	R1/2	G1/2	14	14	31	21	25
RS-TMC-06	73	R3/4	G3/4	16	16,5	33	25	20
RS-TMC-08	90	R1	G2	17,5	19	39	30	10

TAPER LATERAL MALE TEE

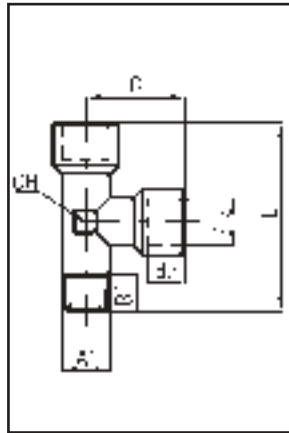

TYPE	L	A1	A2	B1	B2	C	CH	q.ty
RS-TML-M5	22,5	M5	M5	4	5	11	9	50
RS-TML-01	39,5	R1/8	G1/8	8	8	21	10	50
RS-TML-02	49	R1/4	G1/4	11	11	25,5	13	50
RS-TML-03	54	R3/8	G3/8	11,5	11,5	28	17	50
RS-TML-04	64,5	R1/2	G1/2	14	14	33,5	21	25
RS-TML-06	69,5	R3/4	G3/4	16,5	16,5	36,5	25	20
RS-TML-08	84	R1	G1	17,5	19	45	30	10

TAPER MALE TEE

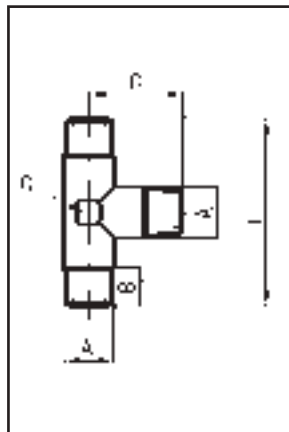

TYPE	L	A	B	C	CH	q.ty
RS-TM-01	37	R1/8	8	18,5	10	50
RS-TM-02	47	R1/4	11	23,5	13	50
RS-TM-03	52	R3/8	11,5	26	17	50
RS-TM-04	62	R1/2	14	31	21	25
RS-TM-06	66,4	R3/4	16,2	33	25	20
RS-TM-08	78	R1	17,5	39	30	10

5

TAPER UNION FEMALE TEE

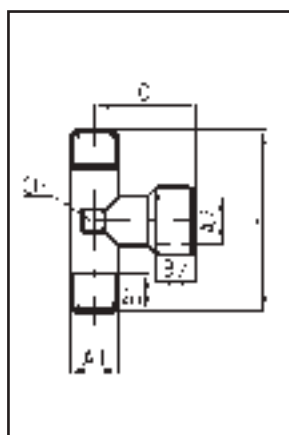

TYPE	L	A1	A2	B1	B2	C	CH	q.ty
RS-TCF-01	37	R1/8	G1/8	8	8	21	10	50
RS-TCF-02	47	R1/4	G1/4	11	11	25,5	13	50
RS-TCF-03	52	R3/8	G3/8	11,5	11,5	28	17	50
RS-TCF-04	62	R1/2	G1/2	14	14	33,5	21	25
RS-TCF-06	66,4	R3/4	G3/4	16,2	16,5	36,5	25	20
RS-TCF-08	78	R1	G1	17,5	19	45	30	10

TAPER LATERAL FEMALE TEE

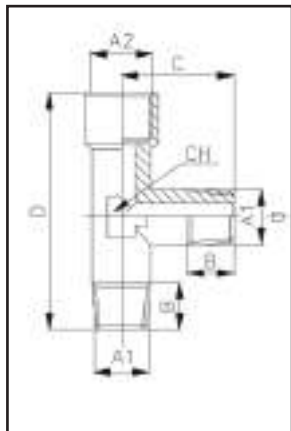

TYPE	A1	A2	B	C	D	CH	q.ty
RS-TLF-01	R1/8	G1/8	8	18,5	39,5	10	50
RS-TLF-02	R1/4	G1/4	11	23,5	49	13	50
RS-TLF-03	R3/8	G3/8	11,5	26	54	17	50
RS-TLF-04	R1/2	G1/2	14	31	64,5	21	25
RS-TLF-06	R3/4	G3/4	16	33	69,5	25	20
RS-TLF-08	R1	G1	17,5	39	84	30	10

FEMALE CROSS

5



TYPE	L	A	B	CH	q.ty
RS-CF-01	42	G1/8	8	10	25
RS-CF-02	51	G1/4	11	13	25
RS-CF-03	56	G3/8	11,5	17	25
RS-CF-04	67	G1/2	14	21	20

TAPER M/F/F/F CROSS (M=MALE; F=FEMALE)



TYPE	L	A1	A2	B	C	CH	q.ty
RS-MFFF-01	42	R1/8	G1/8	8	18,5	10	25
RS-MFFF-02	49	R1/4	G1/4	11	23,5	13	25
RS-MFFF-03	56	R3/8	G3/8	11,5	26	17	25
RS-MFFF-04	67	R1/2	G1/2	14	31	21	20

TAPER MALE Y CONNECTOR

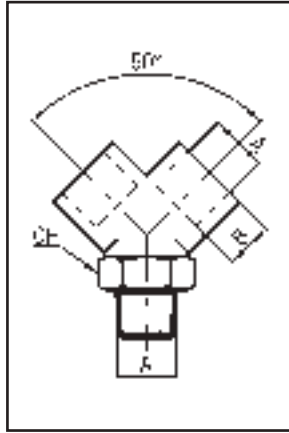

TYPE	A	B	CH	q.ty
RS-YCM-01	R1/8	8	13	25
RS-YCM-02	R1/4	11	17	25
RS-YCM-03	R3/8	11,5	20	20
RS-YCM-04	R1/2	14	25	10

FEMALE Y CONNECTOR

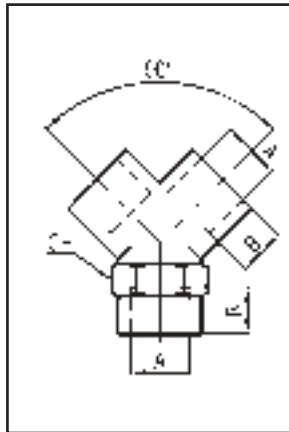

TYPE	A	B	CH	q.ty
RS-YF-01	G1/8	8	13	25
RS-YF-02	G1/4	11	17	25
RS-YF-03	G3/8	11,5	20	20
RS-YF-04	G1/2	14	25	10

5

FEMALE BULKHEAD CONNECTOR

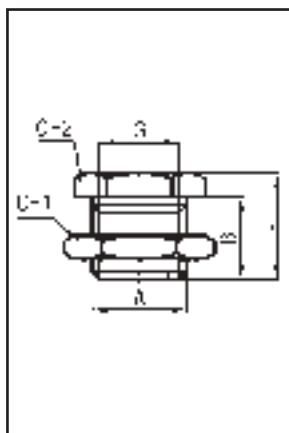

TYPE	L	A	B	G	CH1	CH2	q.ty
RS-PF-M5	14	M10x1	10,5	M5	14	14	50
RS-PF-01	18	M16x1,5	14	G1/8	22	19	50
RS-PF-02	25	M20x1,5	21	G1/4	27	24	50
RS-PF-03	26	M26x1,5	21	G3/8	32	30	25
RS-PF-04	33	M28x1,5	27	G1/2	36	32	20

PARALLEL MALE HOSE ADAPTER

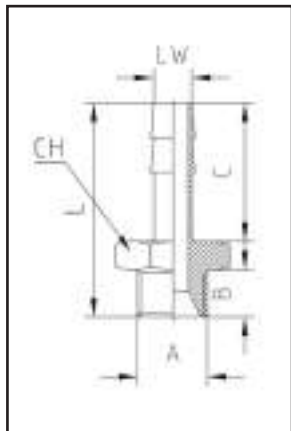

TYPE	L	A	B	C	LW	CH	q.ty
RS-PM-4,5/M5	22,5	M5	4	15	4,5	8	50
RS-PM-6/01	29,5	G1/8	6	19	6	12	50
RS-PM-6/02	32	G1/4	8	19	6	14	50
RS-PM-7/01	29,5	G1/8	6	19	7	12	50
RS-PM-7/02	32	G1/4	8	19	7	14	50
RS-PM-8/01	29,5	G1/8	6	19	8	12	50
RS-PM-8/02	32	G1/4	8	19	8	14	50
RS-PM-8/03	33	G3/8	9	19	8	19	50
RS-PM-9/01	29,5	G1/8	6	19	9	12	50
RS-PM-9/02	32	G1/4	8	19	9	14	50
RS-PM-9/03	33	G3/8	9	19	9	19	50
RS-PM-10/01	30,5	G1/8	6	20	10	12	50
RS-PM-10/02	33	G1/4	8	20	10	14	50
RS-PM-10/03	34	G3/8	9	20	10	19	50
RS-PM-12/02	33	G1/4	8	20	12	14	50
RS-PM-12/03	34	G3/8	9	20	12	19	50
RS-PM-12/04	35,5	G1/2	10	20	12	22	50
RS-PM-14/03	36	G3/8	9	22	14	19	50
RS-PM-14/04	37,5	G1/2	10	22	14	22	50
RS-PM-17/03	38	G3/8	9	24	17	19	50
RS-PM-17/04	39,5	G1/2	10	24	17	22	50
RS-PM-18/06	41,5	G3/4	11	24	18	30	20
RS-PM-20/04	39,5	G1/2	10	24	20	22	25
RS-PM-20/06	41,5	G3/4	11	24	20	30	20

5

TAPER ELBOW HOSE ADAPTER

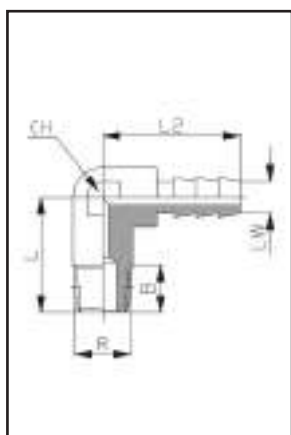

TYPE	L	L2	B	R	LW	CH	q.ty
RS-PG-6/01	18,5	22,5	8	R1/8	6	8	50
RS-PG-6/01A	23	22,5	8	R1/8	6	8	50
RS-PG-6/02	23	23	11	R1/4	6	9	50
RS-PG-7/01	18,5	22,5	8	R1/8	7	8	50
RS-PG-7/01A	23	22,5	8	R1/8	7	8	50
RS-PG-7/02	23	23	11	R1/4	7	9	50

TAPER MALE HOSE ADAPTER

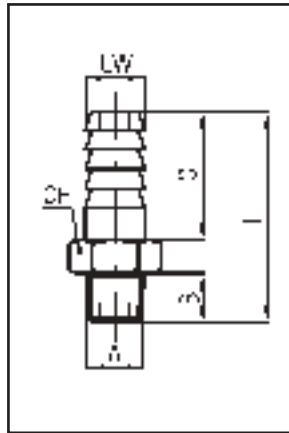

TYPE	L	A	B	C	LW	CH	q.ty
RS1-PM-6/01	31,5	R1/8	8	19	6	12	50
RS1-PM-6/02	35	R1/4	11	19	6	14	50
RS1-PM-7/01	31,5	R1/8	8	19	7	12	50
RS1-PM-7/02	35	R1/4	11	19	7	12	50
RS1-PM-8/01	31,5	R1/8	8	19	8	12	50
RS1-PM-8/02	35	R1/4	11	19	8	14	50
RS1-PM-9/01	31,5	R1/8	8	19	9	12	50
RS1-PM-9/02	35	R1/4	11	19	9	14	50
RS1-PM-9/03	35,5	R3/8	11,5	19	9	17	50
RS1-PM-9/04	38,5	R1/2	14	19	9	22	50
RS1-PM-10/01	32,5	R1/8	8	20	10	12	50
RS1-PM-10/02	36	R1/4	11	20	10	14	50
RS1-PM-10/03	36,5	R3/8	11,5	20	10	17	50
RS1-PM-10/04	39,5	R1/2	14	20	10	22	50
RS1-PM-12/02	36	R1/4	11	20	12	14	50
RS1-PM-12/03	36,5	R3/8	11,5	20	12	17	50
RS1-PM-12/04	39,5	R1/2	14	20	12	22	50
RS1-PM-14/03	38,5	R3/8	11,5	22	14	17	50
RS1-PM-14/04	41,5	R1/2	14	22	14	22	50
RS1-PM-16/03	38,5	R3/8	11,5	22	16	17	50
RS1-PM-16/04	41,5	R1/2	14	22	16	22	50
RS1-PM-16/06	45	R3/4	16,5	22	16	27	50
RS1-PM-17/03	40,5	R3/8	11,5	24	17	18	50
RS1-PM-17/04	43,5	R1/2	14	24	17	22	50
RS1-PM-18/03	40,5	R3/8	11,5	24	18	19	50
RS1-PM-18/04	43,5	R1/2	14	24	18	22	50
RS1-PM-18/06	47	R3/4	16,5	24	18	27	50
RS1-PM-20/03	41	R3/8	11,5	24	20	22	25
RS1-PM-20/04	43,5	R1/2	14	24	20	22	25
RS1-PM-20/06	46,5	R3/4	16,5	24	20	27	20
RS1-PM-25/06	53	R3/4	16,5	30	25	27	20
RS1-PM-25/08	56	R1	19	30	25	34	10

TECHNICAL DATA

Material	Nikel plated brass
Thread	Metric, taper and parallel
Size	M5 ÷ 1/2
Fluid	Air
Max. pressure	Fittings: 18 bar - Flow regulators: 10 bar
Working temperature	-20 + 80 °C
Seals	NBR rubber O-ring
Reccomended tubes materials	Polyamide, polyethylene, polyurethane

TAPER STRAIGHT MALE

5

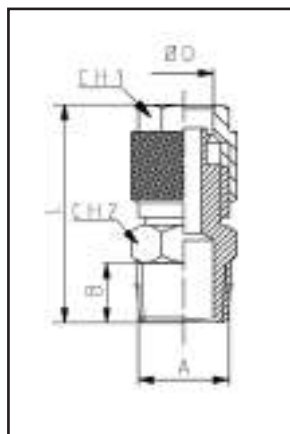

TYPE	L	A	B	ØD	CH1	CH2	q.ty
RC1-DM-4/01	23,8	R1/8	8	4/2,7	8	12	50
RC1-DM-5/01	25	R1/8	8	5/3	8	12	50
RC1-DM-6/01	27,5	R1/8	8	6/4	12	12	50
RC1-DM-6/02	31	R1/4	11	6/4	12	14	50
RC1-DM-6/03	31,5	R3/8	11,5	6/4	12	17	50
RC1-DM-8/01	27,5	R1/8	8	8/6	14	12	50
RC1-DM-8/02	31	R1/4	11	8/6	14	14	50
RC1-DM-8/03	31,5	R3/8	11,5	8/6	14	17	50
RC1-DM-8/04	34,5	R1/2	14	8/6	14	22	50
RC1-DM-10/01	29,5	R1/8	8	10/8	16	14	50
RC1-DM-10/02	32,5	R1/4	11	10/8	16	14	50
RC1-DM-10/03	33	R3/8	11,5	10/8	16	17	25
RC1-DM-10/04	36	R1/2	14	10/8	16	22	25
RC1-DM-12/03	34,5	R3/8	11,5	12/10	18	17	20
RC1-DM-12/04	37,5	R1/2	14	12/10	18	22	20
RC1-DM-15/04	39,5	R1/2	14	15/12,5	22	22	10

PARALLEL STRAIGHT MALE

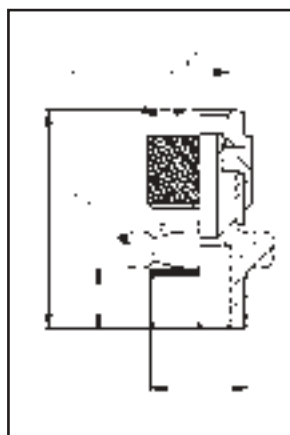

TYPE	L	A	B	ØD	CH1	CH2	q.ty
RC-DM-4/01	25	G1/8	6	4/2,7	7	8	50
RC-DM-5/01	23	G1/8	6	5/3	8	14	50
RC-DM-6/01	25,5	G1/8	6	6/4	12	14	50
RC-DM-6/02	28	G1/4	8	6/4	12	17	50
RC-DM-6/03	29	G3/8	9	6/4	12	19	50
RC-DM-8/01	25,5	G1/8	6	8/6	14	14	50
RC-DM-8/02	28	G1/4	8	8/6	14	17	50
RC-DM-8/03	29	G3/8	9	8/6	14	19	50
RC-DM-10/01	27	G1/8	6	10/8	16	14	50
RC-DM-10/02	29,5	G1/4	8	10/8	16	17	50
RC-DM-10/03	30,5	G3/8	9	10/8	16	19	25
RC-DM-10/04	32	G1/2	10	10/8	16	24	25
RC-DM-12/03	32	G3/8	9	12/10	18	19	20
RC-DM-12/04	33,5	G1/2	10	12/10	18	24	20
RC-DM-15/04	35,5	G1/2	10	15/12,5	22	24	10

PARALLEL STRAIGHT FEMALE

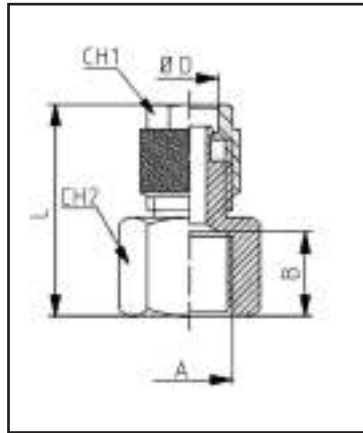

TYPE	L	A	B	ØD	CH1	CH2	q.ty
RC-DF-4/01	21,3	G1/8	8	4/2,7	8	14	50
RC-DF-5/01	22,5	G1/8	8	5/3	8	14	50
RC-DF-6/01	25	G1/8	8	6/4	12	14	50
RC-DF-6/02	29	G1/4	11	6/4	12	17	50
RC-DF-6/03	29,5	G3/8	11,5	6/4	12	20	50
RC-DF-8/01	25	G1/8	8	8/6	14	14	50
RC-DF-8/02	29	G1/4	11	8/6	14	17	50
RC-DF-8/03	29,5	G3/8	11,5	8/6	14	20	50
RC-DF-10/01	26,5	G1/8	8	10/8	16	14	50
RC-DF-10/02	30,5	G1/4	11	10/8	16	17	50
RC-DF-10/03	31	G3/8	11,5	10/8	16	20	25
RC-DF-10/04	34,5	G1/2	14	10/8	16	24	20
RC-DF-12/03	32,5	G3/8	11,5	12/10	18	20	20

BULKHEAD CONNECTOR

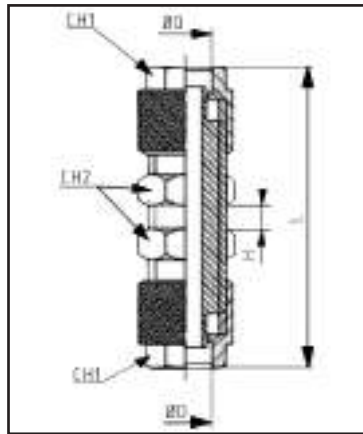

TYPE	L	ØD	H/max	CH1	CH2	q.ty
RC-P4	36,7	4/2,7	8,5	8	8	50
RC-P5	40	5/3	8,5	8	9	50
RC-P6	48	6/4	10,5	12	14	50
RC-P8	48	8/6	10,5	14	16	50
RC-P10	50	10/8	8,5	16	17	25
RC-P12	53	12/10	8,5	18	19	20
RC-P15	58	15/12,5	8,5	22	24	10

5

UNION STRAIGHT

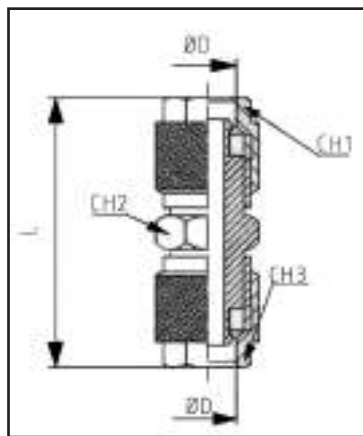

TYPE	L	ØD	CH1	CH2	CH3	q.ty
RC-DI-4	26,1	4/2,7	8	8	8	50
RC-DI-5	28,5	5/3	8	8	8	50
RC-DI-6	34,5	6/4	12	12	12	50
RC-DI-8/6	35	8/6 x 6/4	14	14	12	50
RC-DI-8	35	8/6	14	14	14	50
RC-DI-10	38	10/8	16	16	14	25
RC-DI-12	41	12/10	18	17	18	25
RC-DI-15	45,5	15/12,5	22	22	22	10

TAPER ELBOW MALE

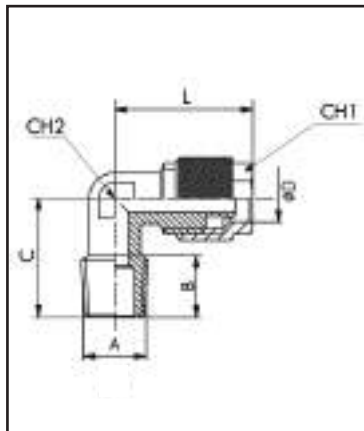

TYPE	L	A	B	C	ØD	CH1	CH2	q.ty
RC1-G-4/01	19,5	R1/8	8	17	4/2,7	8	8	50
RC1-G-5/01	21,5	R1/8	8	17	5/3	8	8	50
RC1-G-6/01	22,5	R1/8	8	17	6/4	12	8	50
RC1-G-6/02	22,5	R1/4	11	20	6/4	12	10	50
RC1-G-6/03	23,5	R3/8	11,5	22,5	6/4	12	11	50
RC1-G-8/01	22,5	R1/8	8	17	8/6	14	10	50
RC1-G-8/02	22,5	R1/4	11	20	8/6	14	10	50
RC1-G-8/03	24	R3/8	11,5	20	8/6	14	11	50
RC1-G-10/01	25,5	R1/8	8	22,5	10/8	16	11	50
RC1-G-10/02	25,5	R1/4	11	18,5	10/8	16	11	50
RC1-G-10/03	25,5	R3/8	11,5	21,5	10/8	16	11	25
RC1-G-10/04	28	R1/2	14	28	10/8	16	17	25
RC1-G-12/02	30	R1/4	11	24	12/10	18	14	20
RC1-G-12/03	30	R3/8	11,5	24,5	12/10	18	14	20
RC1-G-12/04	30,5	R1/2	14	28	12/10	18	17	20
RC1-G-15/04	34	R1/2	14	28	15/12,5	22	17	10

5

PARALLEL SWIVEL ELBOW WITH O-RING

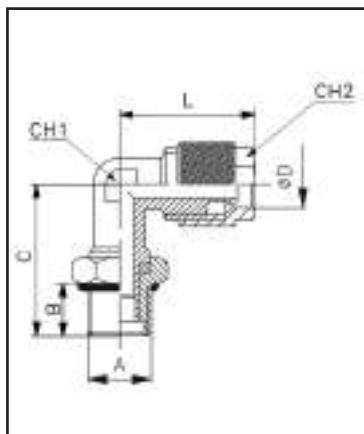

TYPE	L	A	B	C	ØD	CH1	CH2	q.ty
RC-GG-4/01	21,5	G1/8	6	22,5	4/2,7	12	14	50
RC-GG-6/01	22,5	G1/8	6	22,5	6/4	12	14	50
RC-GG-6/02	23,5	G1/4	8	25	6/4	12	17	50
RC-GG-8/01	23,5	G1/8	6	22,5	8/6	14	14	50
RC-GG-8/02	23,5	G1/4	8	25	8/6	14	17	50
RC-GG-10/02	25,5	G1/4	8	25,5	10/8	16	17	25

PARALLEL ELBOW FEMALE

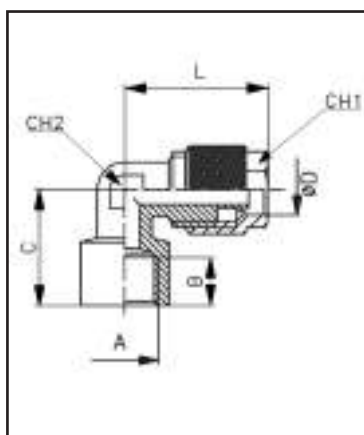

TYPE	L	A	B	C	ØD	CH1	CH2	q.ty
RC-GF-5/01	21,5	G1/8	8	19	5/3	8	10	50
RC-GF-6/01	22,5	G1/8	8	19	6/4	12	10	50
RC-GF-6/02	25	G1/4	10,5	23	6/4	12	11	50
RC-GF-8/01	22,5	G1/8	8	19	8/6	14	10	50
RC-GF-8/02	25	G1/4	10,5	23	8/6	14	11	50
RC-GF-10/02	26	G1/4	11	23,5	10/8	16	13	25
RC-GF-12/03	30,5	G3/8	11,5	28	12/10	18	17	20

UNION ELBOW

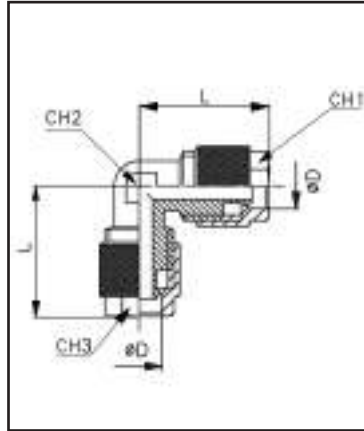

TYPE	L	ØD	CH1	CH2	CH3	q.ty
RC-GI-4	20,3	4/2,7	8	8	8	50
RC-GI-5	21,5	5/3	8	8	8	50
RC-GI-6	21,5	6/4	12	8	12	50
RC-GI-8/6	22,5	8/6	12	10	14	50
RC-GI-8	22,5	8/6	14	10	14	50
RC-GI-10	25,5	10/8	16	11	16	25
RC-GI-12	30	12/10	18	14	18	20
RC-GI-15	34	15/12,5	22	17	22	10

TAPER CENTRAL MALE TEE

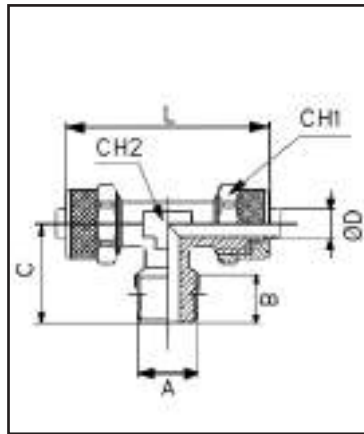

TYPE	L	A	B	C	ØD	CH1	CH2	q.ty
RC1-TC-4/01	40,6	R1/8	8	17	4/2,7	8	8	50
RC1-TC-5/M5	43	M5	4	15	5/3	8	8	50
RC1-TC-5/01	43	R1/8	8	17	5/3	8	8	50
RC1-TC-6/01	45	R1/8	8	17	6/4	11	8	50
RC1-TC-6/02	45,5	R1/4	11	20,5	6/4	11	10	50
RC1-TC-6/03	47	R3/8	11,5	22,5	6/4	12	11	50
RC1-TC-8/01	45,5	R1/8	8	17,5	8/6	14	10	50
RC1-TC-8/02	45,5	R1/4	11	20,5	8/6	14	10	50
RC1-TC-8/03	48	R3/8	11,5	21,5	8/6	14	11	50
RC1-TC-10/01	51	R1/8	8	18,5	10/8	16	11	50
RC1-TC-10/02	51	R1/4	11	21,5	10/8	16	11	50
RC1-TC-10/03	51	R3/8	11,5	22,5	10/8	16	11	25
RC1-TC-10/04	57	R1/2	14	28	10/8	16	17	25
RC1-TC-12/03	60	R3/8	11,5	22,5	12/10	18	14	20
RC1-TC-12/04	61	R1/2	14	28	12/10	18	17	20
RC1-TC-15/04	68	R1/2	14	28	15/12,5	22	17	10

5

PARALLEL SWIVELLING CENTRAL MALE TEE

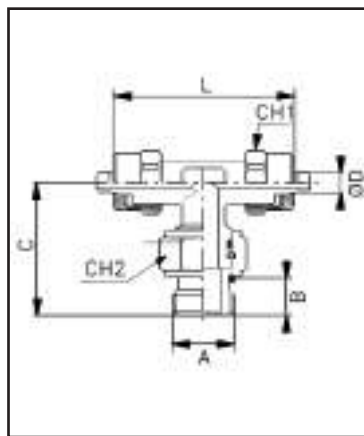

TYPE	L	A	B	C	ØD	CH1	CH2	q.ty
RC-TG-4/01	45	G1/8	6	25,7	4/2,7	8	13	25
RC-TG-6/01	45	G1/8	6	25,7	6/4	12	13	25
RC-TG-6/02	45,5	G1/4	8	29	6/4	12	16	20
RC-TG-8/02	45,5	G1/4	8	28	8/6	14	16	20
RC-TG-10/02	51	G1/4	8	29	10/8	16	16	10

TAPER LATERAL MALE TEE

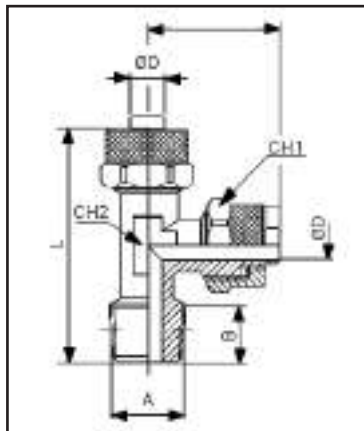

TYPE	L	A	B	C	ØD	CH 1	CH 2	q.ty
RC1-TL-4/01	38	R1/8	8	21,5	4/2,7	8	8	50
RC1-TL-5/M5	36,5	M5	4	21,5	5/3	8	8	50
RC1-TL-5/01	38,5	R1/8	8	21,5	5/3	8	8	50
RC1-TL-6/01	39,5	R1/8	8	22,5	6/4	11	8	50
RC1-TL-6/02	42,5	R1/4	11	22,5	6/4	11	10	50
RC1-TL-6/03	46,5	R3/8	11,5	24	6/4	12	11	50
RC1-TL-8/01	40,5	R1/8	8	22,5	8/6	14	10	50
RC1-TL-8/02	43,5	R1/4	11	22,5	8/6	14	10	50
RC1-TL-8/03	46,5	R3/8	11,5	23,5	8/6	14	11	50
RC1-TL-10/01	44	R1/8	8	25,5	10/8	16	11	50
RC1-TL-10/02	46,5	R1/4	11	25,5	10/8	16	11	50
RC1-TL-10/03	48	R3/8	11,5	25,5	10/8	16	11	25
RC1-TL-10/04	57	R1/2	14	29	10/8	16	17	25
RC1-TL-12/03	54,5	R3/8	11,5	30	12/10	18	14	20
RC1-TL-12/04	58,5	R1/2	14	30,5	12/10	18	17	20
RC1-TL-15/04	62	R1/2	14	34	15/12,5	22	17	10

UNION TEE

5

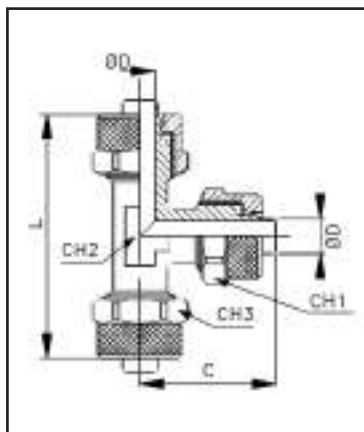

TYPE	L	C	ØD	CH 1	CH 2	CH 3	q.ty
RC-TI-4	20,3	20,3	4/2,7	8	8	8	50
RC-TI-5	43	21,5	5/3	8	8	8	50
RC-TI-6	45	22,5	6/4	12	8	12	50
RC-TI-8/6	45	22,5	8/6	14	10	14	50
RC-TI-8	45	22,5	8/6	12	10	14	50
RC-TI-10	51	25,5	10/8	16	11	16	25
RC-TI-12	60	30	12/10	18	14	18	20
RC-TI-15	68	34	15/12,5	22	17	22	10

CROSS CONNECTOR

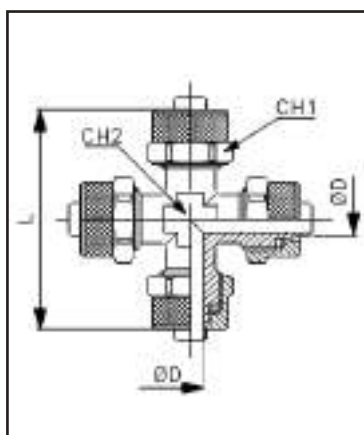

TYPE	L	ØD	CH 1	CH 2	q.ty
RC-C-5	43	5/3	8	8	20
RC-C-6	45	6/4	12	8	20
RC-C-8	45	8/6	14	10	20
RC-C-10	51	10/8	16	11	10

SINGLE BANJO STEM

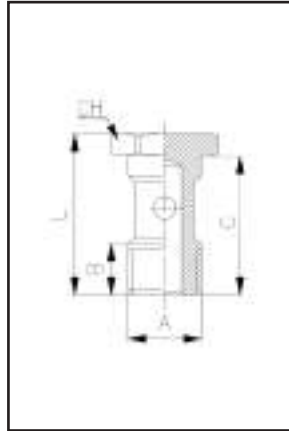

TYPE	L	A	B	C	CH	q.ty
RC-VBS-M5	18	M5	6	14,5	8	50
RC-VBS-M6	18,5	M6	6	14,5	8	50
RC-VBS-01	27	G1/8	8	23	14	50
RC-VBS-02	29,5	G1/4	11	25	17	50

DOUBLE BANJO STEM

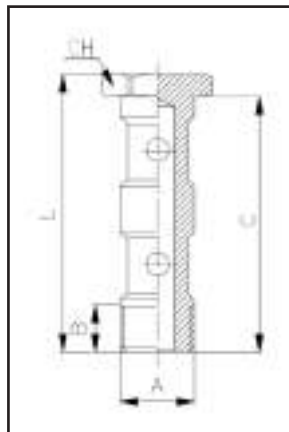

TYPE	L	A	B	C	CH	q.ty
RC-VBD-01	43	G1/8	8	39	14	50
RC-VBD-02	45,5	G1/4	11	41	17	50

5

LOCKING NUT

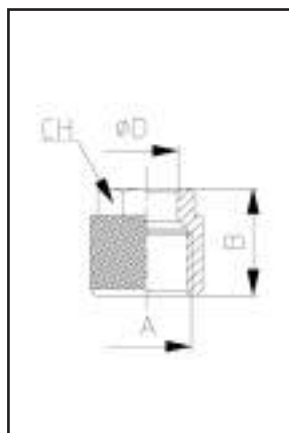

TYPE	A	B	D	CH	q.ty
RC-DS-4/M6	4/2,7	8,1	M6x0,5	8	50
RC-DS-6/M8	6/4	9	M8x0,75	9	50
RC-DS-6/M10	6/4	10,5	M10x1	12	50
RC-DS-8/M12	8/6	10,5	M12x1	14	50
RC-DS-10/M14	10/8	11,5	M14x1	16	25
RC-DS-12/M16	12/10	13	M16x1	18	20
RC-DS-15/M20	15/12,5	15,5	M20x1	22	10

SINGLE BANJO BODY

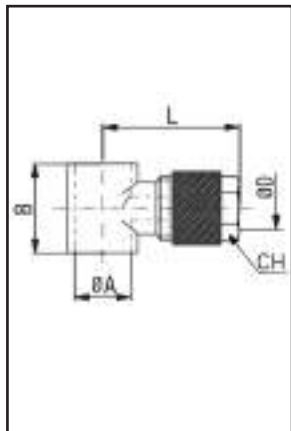

TYPE	L	ØA	B	ØD	CH	q.ty
RC-CBS-4/M5	15,8	M5	9	4/2,7	8	50
RC-CBS-4/M6	15,8	M6	9	4/2,7	8	50
RC-CBS-4/01	21,3	G1/8	14,5	4/2,7	8	50
RC-CBS-5/M5	17	M5	9	5/3	8	50
RC-CBS-5/01	22,5	G1/8	14,5	5/3	8	50
RC-CBS-6/M5	18	M5	9	6/4	9	50
RC-CBS-6/01	24	G1/8	14,5	6/4	12	50
RC-CBS-6/02	26	G1/4	14,5	6/4	12	50
RC-CBS-8/01	24	G1/8	14,5	8/6	14	50
RC-CBS-8/02	26	G1/4	14,5	8/6	14	50
RC-CBS-10/02	27,5	G1/4	14,5	10/8	16	25

5

DOUBLE BANJO BODY

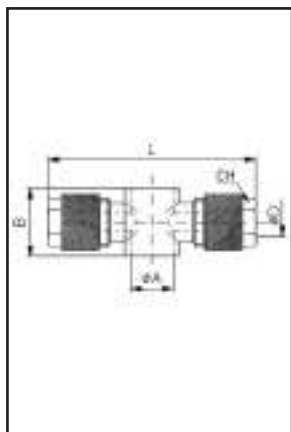

TYPE	L	ØA	B	ØD	CH	q.ty
RC-CBD-4/01	42,6	G1/8	14,5	4/2,7	8	50
RC-CBD-5/01	45	G1/8	14,5	5/3	8	50
RC-CBD-6/01	48	G1/8	14,5	6/4	12	50
RC-CBD-6/02	52	G1/4	14,5	6/4	12	50
RC-CBD-8/01	48	G1/8	14,5	8/6	14	50
RC-CBD-8/02	52	G1/4	14,5	8/6	14	50
RC-CBD-10/02	55	G1/4	14,5	10/8	16	25

FEMALE BANJO BODY

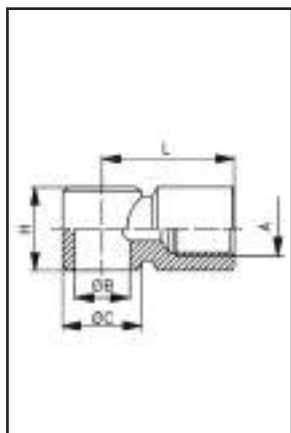

TYPE	L	A	ØB	ØC	H	q.ty
RC-CBF-01	20	G1/8	G1/8	14	14,5	25
RC-CBF-02	24,5	G1/4	G1/4	18	17,5	25
RC-CBF-03	29	G3/8	G3/8	21	21	20

QUICK COUPLER WITH SPRING

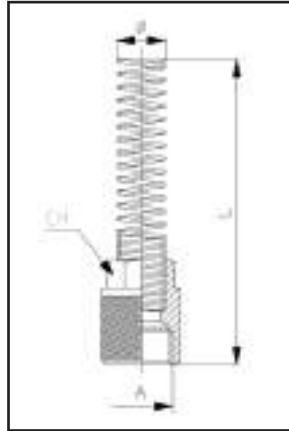

TYPE	L	A	Ø	CH	q.ty
RC-G-6/M10	95	M10x1	6/4	12	10
RC-G-8/M12	93,5	M12x1	8/6	14	10
RC-G-10/M14	96,5	M14x1	10/8	16	10
RC-G-12/M16	106	M16x1	12/10	18	10

TAPER FIXED STRAIGHT MALE ADAPTER + NUT WITH SPRING

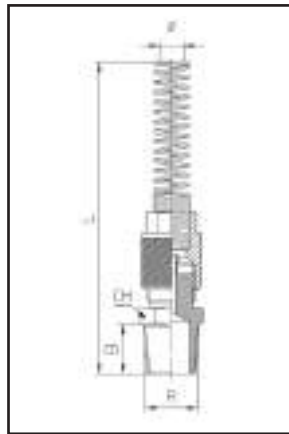

TYPE	L	B	R	Ø	CH	q.ty
RC1-DFM-6/01	109,5	8	1/8	6/4	12	10
RC1-DFM-6/02	113	11	1/4	6/4	14	10
RC1-DFM-8/01	124,5	8	1/8	8/6	12	10
RC1-DFM-8/02	128	11	1/4	8/6	14	10
RC1-DFM-8/03	128,5	11,5	3/8	8/6	17	10
RC1-DFM-8/04	131,5	14	1/2	8/6	22	10
RC1-DFM-10/01	123	8	1/8	10/8	14	10
RC1-DFM-10/02	125	11	1/4	10/8	14	10
RC1-DFM-10/03	125,5	11,5	3/8	10/8	17	10
RC1-DFM-10/04	130	14	1/2	10/8	22	10
RC1-DFM-12/03	134,5	11,5	3/8	12/10	17	10
RC1-DFM-12/04	140	14	1/2	12/10	22	10

5

PARALLEL FIXED STRAIGHT MALE ADAPTER + NUT WITH SPRING

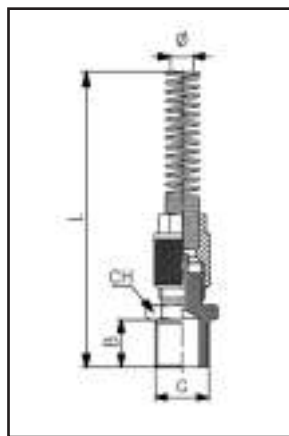

TYPE	L	B	G	Ø	CH	q.ty
RC-DFM-6/01	111	6	1/8	6/4	13	10
RC-DFM-6/02	111	8	1/4	6/4	16	10
RC-DFM-6/03	112	9	3/8	6/4	19	10
RC-DFM-6/04	113	10	1/2	6/4	24	10
RC-DFM-8/01	110	6	1/8	8/6	14	10
RC-DFM-8/02	111	8	1/4	8/6	16	10
RC-DFM-8/03	112	9	3/8	8/6	19	10
RC-DFM-8/04	113	10	1/2	8/6	24	10
RC-DFM-10/01	116	6	1/8	10/8	14	10
RC-DFM-10/02	117	8	1/4	10/8	16	10
RC-DFM-10/03	118,5	9	3/8	10/8	19	10
RC-DFM-10/04	119	10	1/2	10/8	24	10
RC-DFM-12/03	129	9	3/8	12/10	19	10
RC-DFM-12/04	130	10	1/2	12/10	24	10

TAPER SWIVEL STRAIGHT MALE ADAPTER + NUT WITH SPRING

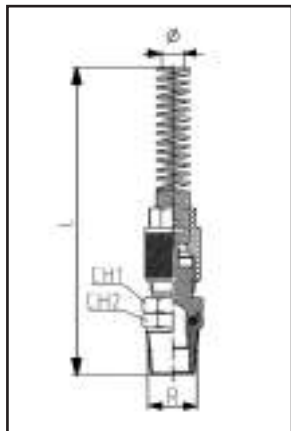

TYPE	L	R	Ø	CH1	CH2	q.ty
RC1-DGM-6/01	116,9	1/8	6/4	15	13	10
RC1-DGM-6/02	118,9	1/4	6/4	15	13	10
RC1-DGM-8/01	122,4	1/8	*8/5	16	16	10
RC1-DGM-8/02	124,4	1/4	*8/5	13	13	10
RC1-DGM-8/01A	122,4	1/8	8/6	16	16	10
RC1-DGM-8/02A	124,4	1/4	8/6	16	16	10
RC1-DGM-10/02	132,4	1/4	*10/6,5	16	16	10
RC1-DGM-10/02A	132,4	1/4	10/8	13	13	10
RC1-DGM-12/03	141,9	3/8	*12/8	16	16	10
RC1-DGM-12/03A	141,9	3/8	12/10	16	16	10

* Specific dimensions for PU tube

PARALLEL SWIVEL STRAIGHT MALE ADAPTER + NUT WITH SPRING

5

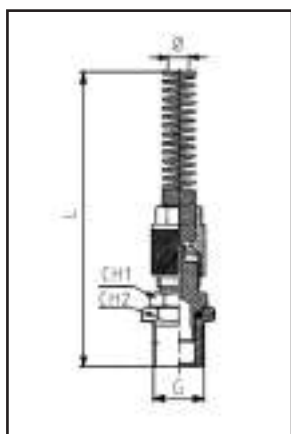

TYPE	L	G	Ø	CH1	CH2	q.ty
RC-DGM-6/01	116,9	1/8	6/4	13	13	10
RC-DGM-6/02	118,9	1/4	6/4	13	13	10
RC-DGM-8/01	122,4	1/8	*8/5	16	16	10
RC-DGM-8/02	124,4	1/4	*8/5	13	13	10
RC-DGM-8/01A	122,4	1/8	8/6	16	16	10
RC-DGM-8/02A	124,4	1/4	8/6	16	16	10
RC-DGM-10/02	132,4	1/4	*10/6,5	16	16	10
RC-DGM-10/02A	132,4	1/4	10/8	13	13	10
RC-DGM-12/03	141,9	3/8	*12/8	16	16	10
RC-DGM-12/03A	141,9	3/8	12/10	16	16	10

* Specific dimensions for PU tube

WASHER

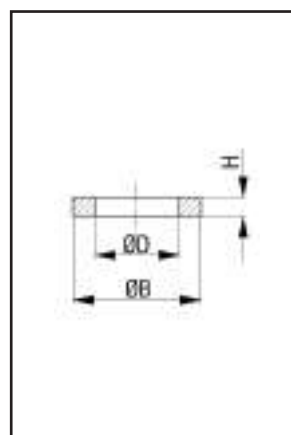

TYPE	ØB	ØD	H	-	q.ty
RO-RD-M5	7,7	5,3	1	M5	100
RO-RD-01	13	10,2	1,5	G1/8	100
RO-RD-02	17,9	13,4	2	G1/4	100
RO-RD-03	21,8	17,1	2	G3/8	100
RO-RD-04	26,5	21,3	2	G1/2	100
RO-RD-06	32,4	26,7	2	G3/4	100

For banjo stem type RC-VBS, RO-VBS and RO-VBD, order No. 2 spacers type RO-RD, to be fitted as follow: one under the head of the screw, and one under the last banjo.

Spacer for RO-VB and RC-VBD*					
TYPE	ØB	ØD	H	-	q.ty
RO-DIS-01	14	10,2	5	G1/8	50
RO-DIS-02	17,5	13,2	5	G1/4	50

* To be fitted between the two rings.

UNIDIRECTIONAL FLOW REGULATOR FOR VALVE (IN)



TYPE	L	A	B	D	Ø	Nl/min*	CH1	CH2	q.ty
RC-RV-5/M5	24,5	M5	4	15	5/3	45	8	8	25
RC-RV-5/01	31,5	G1/8	5,5	23	5/3	310	8	14	25
RC-RV-6/M5	24,5	M5	4	15	6/4	45	9	8	25
RC-RV-6/01	31,5	G1/8	5,5	23	6/4	310	10	14	25
RC-RV-6/02	38	G1/4	6	26	6/4	420	10	17	25
RC-RV-8/01	31,5	G1/8	5,5	23	8/6	310	12	14	25
RC-RV-8/02	38	G1/4	6	26	8/6	420	12	17	25

* Nominal flow rate at 6 bar

UNIDIRECTIONAL FLOW REGULATOR FOR CYLINDER (OUT)



TYPE	L	A	B	D	Ø	Nl/min*	CH1	CH2	q.ty
RC-RC-5/M5	24,5	M5	4	15	5/3	45	8	8	25
RC-RC-5/01	34	G1/8	5,5	23	5/3	310	8	14	25
RC-RC-6/M5	24,5	M5	4	15	6/4	45	9	8	25
RC-RC-6/01	31,5	G1/8	5,5	23	6/4	310	10	14	25
RC-RC-6/02	38	G1/4	6	26	6/4	420	10	17	25
RC-RC-8/01	31,5	G1/8	5,5	23	8/6	310	12	14	25
RC-RC-8/02	38	G1/4	6	26	8/6	420	12	17	25
RC-RC-8/03	47	G3/8	7	26	8/6	500	12	20	25

* Nominal flow rate at 6 bar

TECHNICAL DATA

Material	Nickel plated brass
Thread	Taper and parallel
Size	1/8 ÷ 1/2
Fluid	Air
Max. pressure	60 bar
Working temperature	Max. 150°C
Tubes	Metal tubes and plastic tubes with inner reinforcement

TAPER STRAIGHT MALE

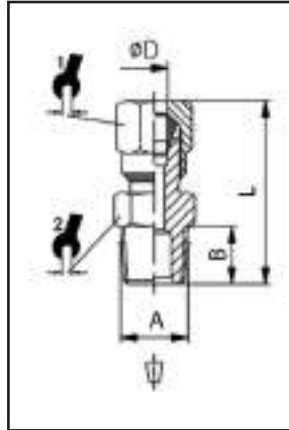

TYPE	L	A	B	ØD	CH1	CH2	q.ty
RG1-DM-4/01	27	R 1/8	8	4	10	10	100
RG1-DM-6/01	28	R 1/8	8	6	12	12	100
RG1-DM-6/02	32,5	R 1/4	11	6	12	14	100
RG1-DM-8/01	29,5	R 1/8	8	8	14	12	100
RG1-DM-8/02	33	R 1/4	11	8	14	14	100
RG1-DM-8/03	33	R 3/8	11,5	8	14	17	100
RG1-DM-10/02	37,5	R 1/4	11	10	19	17	100
RG1-DM-10/03	38	R 3/8	11,5	10	19	17	100
RG1-DM-10/04	40,5	R 1/2	14	10	19	22	50
RG1-DM-12/03	39	R 3/8	11,5	12	22	19	50
RG1-DM-12/04	41	R 1/2	14	12	22	22	50
RG1-DM-14/04	42,5	R 1/2	14	14	27	22	50
RG1-DM-15/04	42,5	R 1/2	14	15	27	22	50
RG1-DM-16/04	42	R 1/2	14	16	30	24	25
RG1-DM-18/04	43	R 1/2	14	18	32	26	25

PARALLEL STRAIGHT MALE

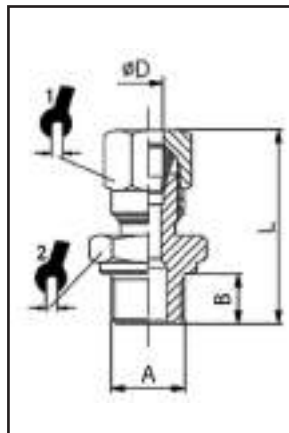

TYPE	L	A	B	ØD	CH1	CH2	q.ty
RG-DM-4/01	25	G 1/8	6	4	10	14	100
RG-DM-6/01	26	G 1/8	6	6	12	13	100
RG-DM-6/02	29,5	G 1/4	8	6	12	17	100
RG-DM-8/01	27,5	G 1/8	6	8	14	14	100
RG-DM-8/02	30	G 1/4	8	8	14	17	50
RG-DM-10/02	34,5	G 1/4	8	10	19	17	50
RG-DM-10/03	36	G 3/8	9	10	19	19	50
RG-DM-12/03	40	G 3/8	10	12	22	22	50
RG-DM-12/04	42	G 1/2	12	12	22	27	50

PARALLEL STRAIGHT FEMALE



TYPE	L	A	B	ØD	CH1	CH2	q.ty
RG-DF-4/01	24,5	G 1/8	8	4	10	14	100
RG-DF-6/01	25,5	G 1/8	8,5	6	12	14	100
RG-DF-6/02	30	G 1/4	11	6	12	17	100
RG-DF-8/01	26,5	G 1/8	8	8	14	14	100
RG-DF-8/02	31	G 1/4	11	8	14	17	100
RG-DF-8/03	31	G 3/8	11,5	8	14	20	100
RG-DF-10/02	35,5	G 1/4	11	10	19	17	100
RG-DF-10/03	36,5	G 3/8	11,5	10	19	20	100
RG-DF-12/03	35	G 3/8	11,5	12	22	20	50
RG-DF-12/04	37	G 1/2	15	12	22	24	50
RG-DF-14/04	40	G 1/2	15	14	27	24	50
RG-DF-15/04	40	G 1/2	15	15	27	24	50
RG-DF-16/04	40,5	G 1/2	15	16	30	24	50
RG-DF-18/04	40	G 1/2	15	18	32	26	50

UNION STRAIGHT

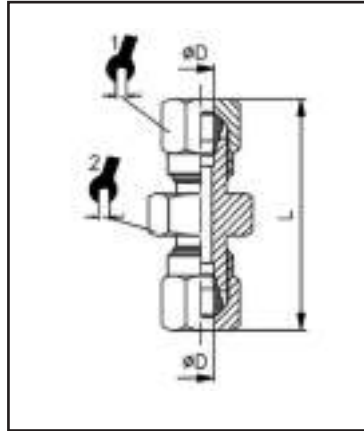

TYPE	L	ØD	CH1	CH2	q.ty
RG-DI-4	34	4	10	10	100
RG-DI-6	35	6	12	12	100
RG-DI-8	38,5	8	14	14	100
RG-DI-10	47,5	10	19	17	100
RG-DI-12	46	12	22	19	50
RG-DI-14	53	14	27	24	50
RG-DI-15	50	15	27	24	50
RG-DI-16	53,5	16	30	27	25
RG-DI-18	53	18	32	27	25

BULKHEAD CONNECTOR

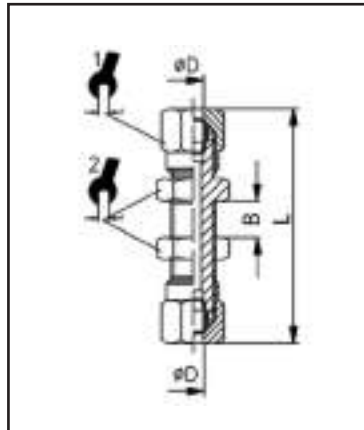

TYPE	B max	L	ØD	CH1	CH2	q.ty
RG-P-6	15,5	51,5	6	12	14	100
RG-P-8	16,5	55,5	8	14	16	100
RG-P-10	15,5	62,5	10	19	19	50
RG-P-12	16	64,5	12	22	22	50
RG-P-15	18	69,5	15	27	25	50

5

TAPER FIXED MALE ELBOW

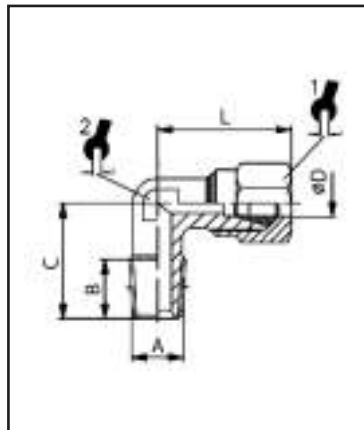

TYPE	L	A	B	C	ØD	CH1	CH2	q.ty
RG1-GM-4/01	21	R 1/8	8	16	4	10	9	100
RG1-GM-6/01	22	R 1/8	8	16	6	12	9	100
RG1-GM-6/02	24,5	R 1/4	11	20	6	12	11	100
RG1-GM-8/01	24	R 1/8	8	17	8	14	11	100
RG1-GM-8/02	24	R 1/4	11	20	8	14	11	100
RG1-GM-8/03	27	R 3/8	11,5	24	8	14	13	100
RG1-GM-10/02	32	R 1/4	11	23,5	10	19	13	100
RG1-GM-10/03	32	R 3/8	11,5	24	10	19	13	100
RG1-GM-10/04	34	R 1/2	14	28,5	10	19	15	50
RG1-GM-12/03	34,5	R 3/8	11,5	25,5	12	22	15	50
RG1-GM-12/04	34,5	R 1/2	14	28,5	12	22	15	50
RG1-GM-14/04	38	R 1/2	14	30	14	27	17	50
RG1-GM-15/04	38	R 1/2	14	30	15	27	17	50
RG1-GM-16/04	39,5	R 1/2	14	31,5	16	30	19	25
RG1-GM-18/04	44	R 1/2	14	34	18	32	22	25

UNION ELBOW

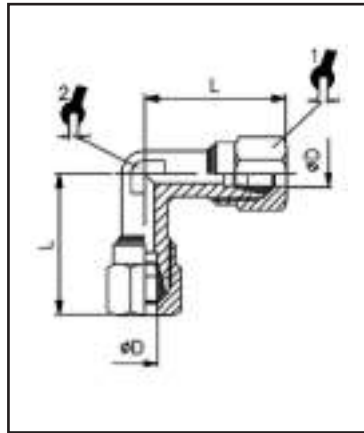

TYPE	L	ØD	CH1	CH2	q.ty
RG-GI-4	21	4	10	9	100
RG-GI-6	23	6	12	9	100
RG-GI-8	24	8	14	11	100
RG-GI-10	32	10	19	13	50
RG-GI-12	34,5	12	22	15	50
RG-GI-14	38	14	27	17	25
RG-GI-15	38	15	27	17	25
RG-GI-16	39,5	16	30	19	25
RG-GI-18	44	18	32	22	25

5

TAPER CENTRAL MALE TEE

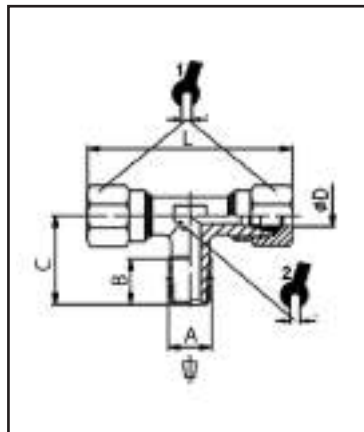

TYPE	L	A	B	C	ØD	CH1	CH2	q.ty
RG1-TC-4/01	42	R 1/8	8	16	4	10	9	100
RG1-TC-6/01	46	R 1/8	8	16	6	12	9	100
RG1-TC-6/02	48	R 1/4	11	20	6	12	11	100
RG1-TC-8/01	48	R 1/8	8	17	8	14	11	100
RG1-TC-8/02	48	R 1/4	11	20	8	14	11	100
RG1-TC-8/03	54	R 3/8	11,5	24	8	14	13	100
RG1-TC-10/02	64	R 1/4	11	23,5	10	19	13	100
RG1-TC-10/03	64	R 3/8	11,5	24	10	19	13	100
RG1-TC-12/03	69	R 3/8	11,5	25,5	12	22	15	50
RG1-TC-12/04	69	R 1/2	14	28,5	12	22	14	50
RG1-TC-14/04	76	R 1/2	14	30	14	27	17	50
RG1-TC-15/04	76	R 1/2	14	30	15	27	17	50
RG1-TC-16/04	79	R 1/2	14	31,5	16	30	19	50
RG1-TC-18/04	88	R 1/2	14	34	18	32	22	25

TAPER LATERAL MALE TEE

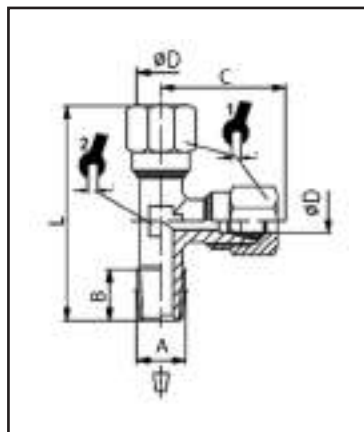

TYPE	L	A	B	C	ØD	CH1	CH2	q.ty
RG1-TL-4/01	37	R 1/8	8	21	4	10	9	100
RG1-TL-6/01	39	R 1/8	8	23	6	12	9	100
RG1-TL-6/02	44,5	R 1/4	11	24,5	6	12	11	100
RG1-TL-8/01	41	R 1/8	8	24	8	14	11	100
RG1-TL-8/02	44	R 1/4	11	24	8	14	12	100
RG1-TL-8/03	51	R 3/8	11,5	27	8	14	13	100
RG1-TL-10/02	55,5	R 1/4	11	32	10	19	13	100
RG1-TL-10/03	56	R 3/8	11,5	32	10	19	13	100
RG1-TL-12/03	60	R 3/8	11,5	34,5	12	22	15	50
RG1-TL-12/04	63	R 1/2	14	34,5	12	22	15	50
RG1-TL-14/04	68	R 1/2	14	38	14	27	17	50
RG1-TL-15/04	68	R 1/2	14	38	15	27	17	50
RG1-TL-16/04	71	R 1/2	14	39,5	16	30	19	50
RG1-TL-18/04	78	R 1/2	14	44	18	32	22	25

UNION TEE

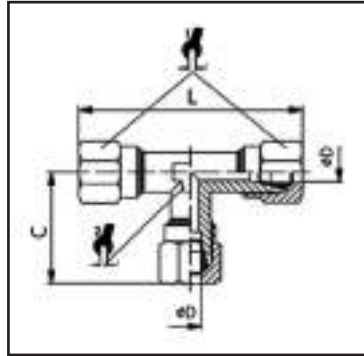

TYPE	L	C	ØD	CH1	CH2	q.ty
RG-TI-4	42	21	4	10	9	50
RG-TI-6	46	23	6	12	9	50
RG-TI-8	48	24	8	14	11	50
RG-TI-10	64	32	10	19	13	50
RG-TI-12	69	34,5	12	22	15	50
RG-TI-14	76	38	14	27	17	50
RG-TI-15	76	38	15	27	17	50
RG-TI-16	79	39,5	16	30	19	25
RG-TI-18	88	44	18	32	22	25

UNION NUT

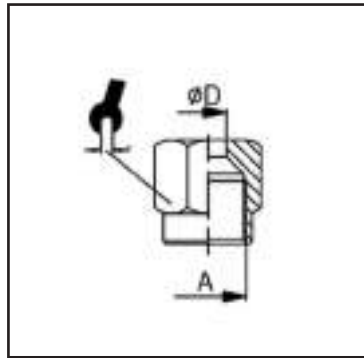

TYPE	A	ØD	CH1	q.ty
RG-D-4	M8X1	4	10	100
RG-D-6	M10X1	6	12	100
RG-D-8	M12X1	8	14	100
RG-D-10	M16X1,5	10	19	100
RG-D-12	M18X1,5	12	22	100
RG-D-14	M22X1,5	14	27	100
RG-D-15	M22X1,5	15	27	100
RG-D-16	M24X1,5	16	30	50
RG-D-18	M26X1,5	18	32	50

5

OGIVE

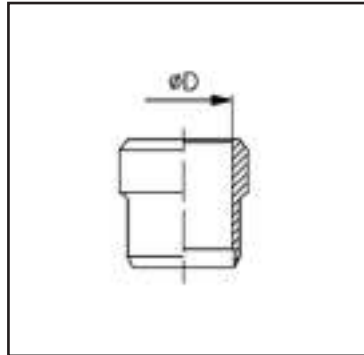

TYPE	ØD	q.ty
RG-O-4	4	100
RG-O-6	6	100
RG-O-8	8	100
RG-O-10	10	100
RG-O-12	12	100
RG-O-14	14	100
RG-O-15	15	100
RG-O-16	16	50
RG-O-18	18	50

REINFORCING SLEEVE

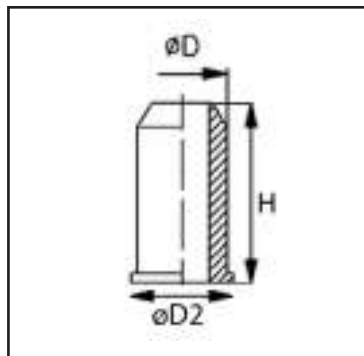

TYPE	ØD1	ØD2	H	q.ty
RG-AR-2	2	3,5	8	100
RG-AR-4	4	5	10	100
RG-AR-6	6	8	15	100
RG-AR-8	8	10	15	100
RG-AR-10	10	12	15	100
RG-AR-12	12	14,3	15	100
RG-AR-14	14	17,3	18	100
RG-AR-18	18	21,3	20	100

TECHNICAL DATA

Body	Nickel-plated brass
Ball	Hard chromium-plated brass
Lever	Polyamide
Seals	Polytetrafluoroethylene
O-Ring	NBR rubber
Surface treatment	Chromium- plating
Thread	Taper and parallel
Size	1/8 ÷ 3/4
Max. pressure	20 bar
Working temperature	-18 ÷ +80 °C
Acuation	90°
Nominal orifice	5 ÷ 14 mm
Flow direction	Bidirectional

5 FEMALE/FEMALE WITH HEXAGONAL BODY

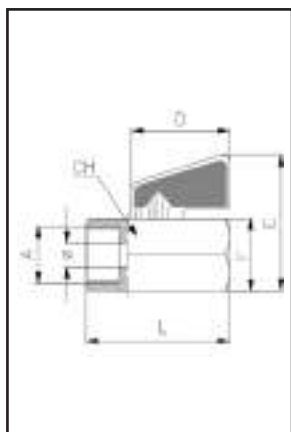

TYPE	L	A	D	E	F	Ø	CH	q.ty
VSR-FF-01	40	G1/8	30	38	21	6	21	20
VSR-FF-02	40	G1/4	22	38	21	8	21	20
VSR-FF-03	40	G3/8	22	38	21	8	21	20
VSR-FF-04	46	G1/2	22	42	25	10	25	20
VSR-FF-06	52	G3/4	22	48	30	14	30	15

MALE/FEMALE WITH HEXAGONAL BODY

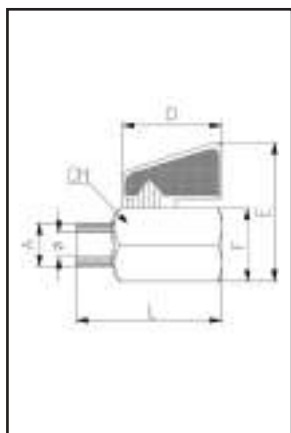

TYPE	L	A	D	E	F	Ø	CH	q.ty
VSR-MF-01	40	G1/8	30	38	21	6	21	20
VSR-MF-02	39	G1/4	22	38	21	8	21	20
VSR-MF-03	40	G3/8	22	38	21	8	21	20
VSR-MF-04	48	G1/2	22	42	25	10	25	20
VSR-MF-06	54	G3/4	22	48	30	14	30	15

FEMALE/FEMALE

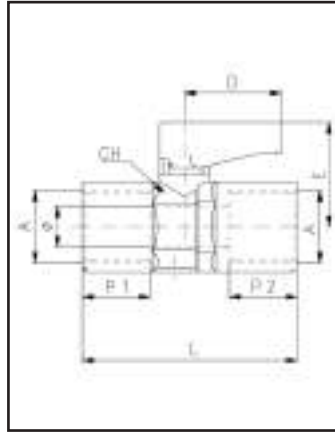

TYPE	L	A	P1	P2	D	E	Ø	CH	q.ty
VS-FF-01	36,5	G1/8	8	8	19	21,5	5,5	14	20
VS-FF-02	43	G1/4	11	11	19	21,5	5,5	14	20
VS-FF-03	48	G3/8	11,5	16	18	22,5	7	18	20
VS-FF-04	59	G1/2	16	23	25	32	10	22	20

MALE/FEMALE WITH TAPER THREAD

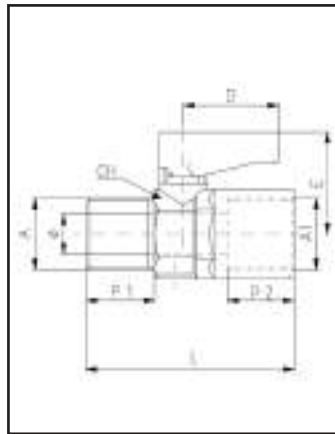

TYPE	L	A	A1	D	E	P1	P2	Ø	CH	q.ty
VS1-MF-01	35,5	R1/8	G1/8	19	21,5	8	8	5,5	14	20
VS1-MF-02	40,5	R1/4	G1/4	19	21,5	11	11	5,5	14	20
VS1-MF-03	48	R3/8	G3/8	19	22,5	13	16	8	18	20
VS1-MF-04	58	R1/2	G1/2	26	32	17	23	10	22	20

5

MALE/FEMALE WITH PARALLEL THREAD

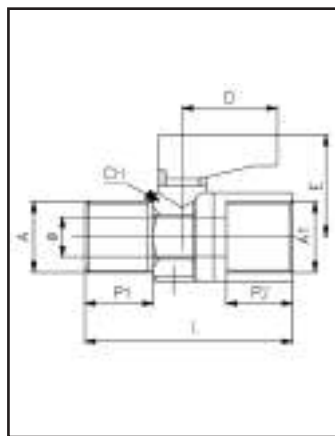

TYPE	L	A	A1	D	E	P1	P2	Ø	CH	q.ty
VS-MF-01	34,5	G1/8	G1/8	19	21,5	7	8	5,5	14	20
VS-MF-02	35,5	G1/4	G1/4	19	21,5	8	8	5,5	14	20
VS-MF-03	37,5	G3/8	G3/8	19	21,5	8	11	5,5	14	20
VS-MF-04	38,5	G1/2	G1/2	19	21,5	8	11	5,5	14	20

Silencers

PARALLEL SILENCER

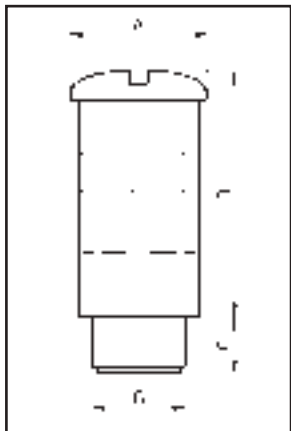

TYPE	A	C	D	G	q.ty
ES8/N	15,5	6	26,5	1/8	100
ES4/N	19,5	8	35	1/4	100
ES3/N	24,5	11	47	3/8	50
ES2/N	24,5	11	47	1/2	50
ES15/N	48	18	97	3/4	10
ES1/N	48	18	97	1	10

Body: Acetal resin
Filter: Granulate ABS

FLAT SILENCER

5

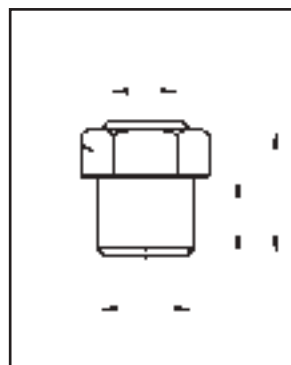

TYPE	L	B	ØD	G	CH	q.ty
SP-M5	9,5	5	6,4	M5	9	50
SP-01	11	6	10	G1/8	12	50
SP-02	14,5	8,5	13	G1/4	16	50
SP-03	17	10	16	G3/8	19	50
SP-04	19	11	17	G1/2	22	20

Body: Brass
Filter: Spherical sintered bronze 100 µm

CONICAL SILENCER

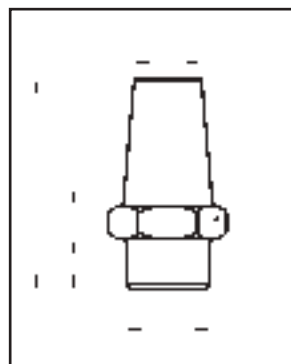

TYPE	L	B	ØD	F	R	CH	q.ty
SC-M5	20	3,5	5,5	5	M5	10	100
SC-01	24	4	8	6	G1/8	13	50
SC-02	33	4	11	8	G1/4	17	50
SC-03	44	5	14	10	G3/8	22	50
SC-04	49	6,5	18	10	G1/2	24	50
SC-06	57	7,5	21	11	G3/4	30	50
SC-08	72	8,5	27	15,5	G1	36	50

Body: Brass
Filter: Spherical sintered bronze 36 µm

HIDDEN SILENCER

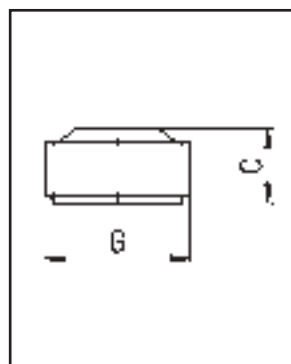

TYPE	C	G	q.ty
SS-01	4	G1/8	100
SS-02	6	G1/4	50
SS-03	8	G3/8	50
SS-04	9	G1/2	25
SS-06	8	G3/4	10
SS-08	10	G1	5

Body: Brass
Filter: Spherical sintered bronze 50 µm

DESCRIPTION

Polyurethane tubes type T-PU have been designed to satisfy the needs of "heavy duty" applications such oleo-dynamics, robotics, pneumatics, tools & industrial machinery thanks to their outstanding technical features. These tubes show very high flexibility to low temperatures, low sensibility to "click" and "stress cracking" effects, excellent resistance to abrasion, good resistance to atmospheric agents, good aging, extremely resistant to exertion.

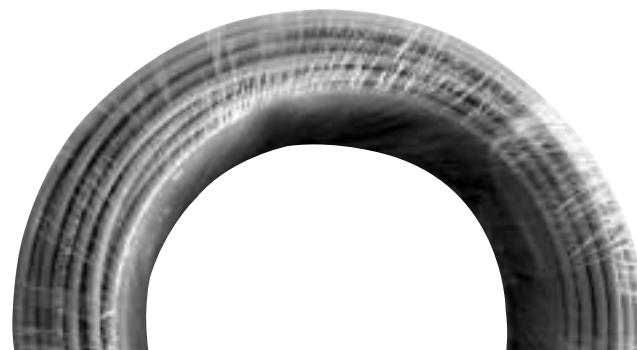

TECHNICAL DATA

Working temperature	-20 ÷ +70°C
Hardness	98 ShA/52ShD
Density	1.22 g/cm ³
Elongation at break	500 %
Tear resistance	130 N/mm
Flexural modulus	140 MPa
Abrasion loss	25 mm ³
Break resistance	55 MPa

MATERIALS

Tube	Poliurethane 98 ShA
Standard colour	Sky-Blue (SB)
Alternative colors upon request	Red (R) - Green (G) - Yellow (Y) Cyan (CN) - Black (BK) Grey (GY) - Natural (N)

MEAN FEATURES TUBES T-PU

Ø (mm)		BURSTING PRESSURE (bar) 23°C	WORKING PRESSURE (bar) 23°C	BENDING RAY (mm)	REELS LENGHT (m)	TYPE
External	Internal					
4	2	60	15	11	100	T-PU-4X2
6	4	40	10	18	100	T-PU-6X4
8	5	52	13	25	100	T-PU-8X5
8	5,5	40	10	30	100	T-PU-8X5,5
8	6	28	7	35	100	T-PU-8X6
10	7	35	8,5	30	100	T-PU-10X7
10	7,5	30	7,5	40	100	T-PU-10X7,5
10	8	27	5,5	45	100	T-PU-10X8
12	9	25	6	50	100	T-PU-12X9

P.S.: Please specify the colour of the tube with the order

ALTERATION SCALE ACCORDING TO TEMPERATURE

Temperature	-20°C	0°C	+23°C	+30°C	+40°C	+50°C	+60°C
Coefficient	x 1,87	x 1,4	x 1	x 0,84	x 0,70	x 0,60	x 0,52

P.S.: This information is only indicative. The validation of the application is at the user charge. For this kind of tubing the manufacturer suggests to use a working pressure of 1/4 than the bursting pressure. These tubing respect the tolerance indicated in the DIN 73 378 standard.

ATTENTION

The use of this tubing typology with continuous pulsing pressure can create heat accumulation, although it is particularly resistant to labour and tension flexions. Polyurethane is generally resistant to ozone, oil, fats, fuels and chemical solutions. Polyurethane is not resistant, or low resistant, to concentrate acids, keton, hydrocarbon and chloride.

DESCRIPTION

Polyamide tubes type T-PA12 are for technical applications due to their characteristics of flexibility and mechanical performances. These tubes show high mechanical properties to traction and to continuous & alternate flexion, notable flexibility, good stability to heat, remarkable resistance to aging, low water absorption, remarkable resistance to hydrocarbons and oils and good inertness to chemical agents.

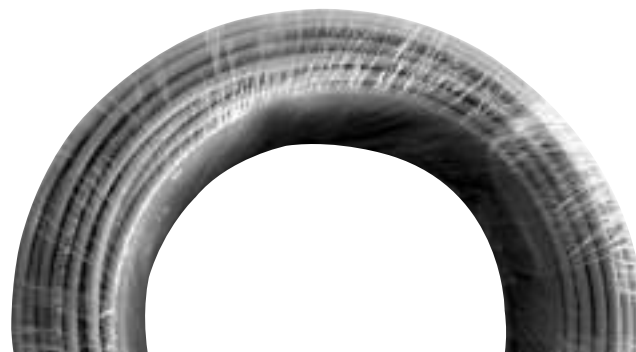

TECHNICAL DATA

Working temperature	-40 ÷ +70°C
Hardness	65 ShD
Density	1.03 g/cm ³
Elongation at break	> 300 %
Tear resistance	130 N/mm
Flexural modulus	410 MPa

MATERIALS

Tube	Polyamide (PA12)
Standard colour	Sky Blue (SB)
Alternative colours upon request	Red (R) - Green (G) - Yellow (Y) - Blue (B) Orange (O) - Black (BK) - Grey (GY) Natural (N) - Brown (M)

5

MAIN FEATURES TUBES T-PA12

Ø (mm)		BURSTING PRESSURE (bar) 23°C	WORKING PRESSURE (bar) 23°C	BENDING RAY (mm)	REELS LENGTH (m)	TYPE
External	Internal					
4	2	130	44	15	100	T-PA12-4X2
4	2,5	108	36	20	100	T-PA12-4X2,5
4	2,7	78	26	25	100	T-PA12-4X2,7
6	4	81	27	30	100	T-PA12-6X4
8	6	60	20	40	100	T-PA12-8X6
10	8	45	15	60	100	T-PA12-10X8
12	10	39	13	85	100	T-PA12-12X10

P.S.: Please specify the colour of the tube with the order

ALTERATION SCALE ACCORDING TO TEMPERATURE

Temperature	-20°C	0°C	+23°C	+30°C	+40°C	+50°C	+60°C
Coefficient	x 1,87	x 1,4	x 1	x 0,90	x 0,80	x 0,70	x 0,60

P.S.: This information is only indicative. The validation of the application is at the user charge. For this kind of tubing the manufacturer suggests to use a working pressure of 1/4 than the bursting pressure. These tubing respect the tolerance indicated in the DIN 73 378 standard.

DESCRIPTION

Polyethylene tubes type T-PELD are particularly indicated for all applications where there are not specific problems pressures and very high temperatures. These tubes are totally recyclable and show high impact resistance, low sensibility to "click" and "stress cracking" effect, excellent resistance to chemical agents, good electrical properties, optimal flexibility.

TECHNICAL DATA

Working temperature	-20 ÷ +60°C
Density	0.921 g/cm ³
Elongation at break	400 %
Tear resistance	30 N/mm
Impact resistance	310 g
Flexural modulus	100 MPa
Tensile strenght at break	26 MPa

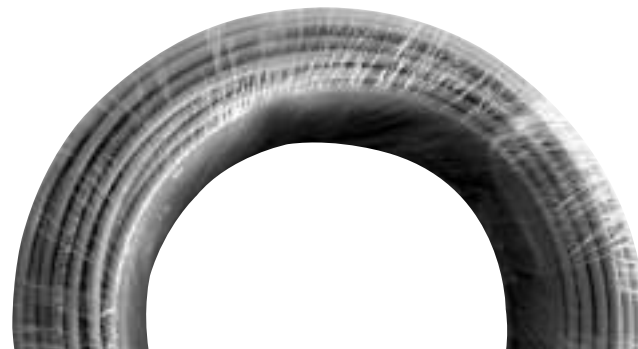

MATERIALS

Tube	Polyethylene low density (PELD)
Standard colour	Sky Blue (SB)
Alternative colours upon request	Red (R) - Green (G) - Yellow (Y) - Blue (B) Orange (O) - Black (BK) - Grey (GY) Natural (N) - Brown (M)

MAIN FEATURES TUBES T-PELD

Ø (mm)		BURSTING PRESSURE (bar) 23°C	WORKING PRESSURE (bar) 23°C	BENDING RAY (mm)	REELS LENGTH (m)	TYPE
External	Internal					
4	2	75	18,5	20	100	T-PELD-4X2
4	2,5	60	15	25	100	T-PELD-4X2,5
5	3	50	12,5	30	100	T-PELD-5X3
6	4	40	10	40	100	T-PELD-6X4
6,35	4,35	36	9	50	100	T-PELD-6,35X4,35
8	6	30	7,5	50	100	T-PELD-8X6
9,54	6,36	40	10	100	100	T-PELD-9,54X6,36
10	8	25	6	120	100	T-PELD-10X8
12	8	30	7,5	160	100	T-PELD-12X8
12	9	28	7	120	100	T-PELD-12X9
12	10	20	5	120	100	T-PELD-12X10

P.S.: Please specify the colour of the tube with the order

ALTERATION SCALE ACCORDING TO TEMPERATURE

Temperature	-20°C	0°C	+23°C	+30°C	+40°C	+50°C	+60°C
Coefficient	x 1,87	x 1,4	x 1	x 0,80	x 0,60	x 0,50	x 0,40

P.S.: This information is only indicative. The validation of the application is at the user charge. For this kind of tubing the manufacturer suggests to use a working pressure of 1/4 than the bursting pressure. These tubing respect the tolerance indicated in the DIN 73 378 standard.

ATTENTION

It is recommended to avoid connecting the polyethylene tubing with fittings that may deform its extremity, because this material does not resist to enlargements approximately over 15%. "Creep" problems could occur with non-suitable fittings.

ALPHANUMERIC INDEX

ITEM	PAGE	ITEM	PAGE	ITEM	PAGE	ITEM	PAGE
Ø/BM/Z/mm	1.96	Ø/stroke YPB	1.102	Ø/SG/R/X	1.21	ØstrokeXT/_1	1.25
Ø/BP/Z/mm	1.96	Ø/stroke YVB	1.102	Ø/SG/R/X	1.25	ØstrokeXT/_3	1.25
Ø/stroke_BXA8	1.67	Ø/stroke Z_ _1	1.96	Ø/SG/R/X2	1.21	ØFstroke_BX_	1.67
Ø/stroke APD-2	1.18	Ø/stroke Z_ _2	1.96	Ø/SG/R/X2	1.25	ØHstroke PDC	1.15
Ø/stroke APDC	1.18	Ø/stroke ZK	1.96	Ø/SG/R/XL	1.29	ØHstroke PDE	1.15
Ø/stroke APDE	1.18	Ø/stroke ZKF	1.96	Ø/SG/R/XL2	1.29	ØHstroke UDC	1.3
Ø/stroke AU_ _2	1.12	Ø/stroke ZKFF	1.96	Ø/SG/RA/CPA/M	1.91	ØHstroke UDE	1.3
Ø/stroke AU_ _X	1.12	Ø/stroke ZS	1.96	Ø/SG/X	1.21	ØPstroke 1 + stroke 2 CX_	1.57
Ø/stroke AUDC	1.12	Ø/stroke ZSF	1.96	Ø/SG/X	1.25	ØPstroke1+stroke2_BX_	1.67
Ø/stroke AUDE	1.12	Ø/stroke ZSFF	1.96	Ø/SG/X2	1.21	ØPstroke1+stroke2_BU_	1.75
Ø/stroke CF	1.2	Ø/stroke_CBC	1.102	Ø/SG/X2	1.25	Øpstroke1+stroke2_BU_M_	1.75
Ø/stroke CL	1.2	Ø/stroke_FPBC	1.102	Ø/SG/XL	1.29	ØPstroke1+stroke2_BU_M1_	1.75
Ø/stroke CPA/M	1.91	Ø/stroke AX	1.50	Ø/SG/XL2	1.29	ØPstroke1+stroke2_BU_M2_	1.75
Ø/stroke CPU	1.63	Ø/stroke AX2	1.50	Ø/SG/Z	1.96	ØPstroke1+stroke2_BU_M3_	1.75
Ø/stroke CPU/FM	1.63	Ø/stroke X / _ _ _4	1.21	Ø_ stroke CPA/M1	1.91	ØPstroke1+stroke2_BU1_	1.75
Ø/stroke CPU_4	1.63	Ø/stroke X / _2	1.21	Ø_ stroke_ABX2_	1.72	ØPstroke1+stroke2_BU2_	1.75
Ø/stroke CPU_6	1.63	Ø/stroke X / _Z	1.21	Ø_ stroke CPU_ 1	1.63	ØPstroke1+stroke2_BU3_	1.75
Ø/stroke CX	1.57	Ø/stroke X /-5	1.21	Ø_ stroke CPU2	1.63	ØPstroke1+stroke2X/-	1.21
Ø/stroke CX/FM	1.57	Ø/stroke XL / _ _ _4	1.29	Ø_ stroke CPU3	1.63	ØPstroke1+stroke2XL/-	1.29
Ø/stroke DABX_	1.72	Ø/stroke XL / _2	1.29	Ø_ stroke CX_ 1	1.57	ØPstroke1+stroke2XT/-	1.25
Ø/stroke DBGB	1.88	Ø/stroke XL / _Z	1.29	Ø_ stroke CX_ 3	1.57	ØR stroke PDE	1.15
Ø/stroke DBGBD	1.88	Ø/stroke XL /-5	1.29	Ø_ stroke CX_ _4	1.57	ØRAstroke CPA/M	1.91
Ø/stroke DBGGM	1.88	Ø/stroke XT / _ _ _4	1.25	Ø_ stroke CX_ _6	1.57	ØRstroke AUDC	1.12
Ø/stroke DBGMD	1.88	Ø/stroke XT / _2	1.25	Ø_ stroke CX2	1.57	ØRstroke_ABX_	1.72
Ø/stroke DBX_	1.67	Ø/stroke XT / _Z	1.25	Ø_ stroke_BU_	1.75	ØRstroke APDC_	1.18
Ø/stroke DCB	1.102	Ø/stroke XT /-5	1.25	Ø_ stroke_BU_M_	1.75	ØRstroke APDE_	1.18
Ø/stroke DFAB	1.102	Ø/SG/ABX	1.72	Ø_ stroke_BU_M1_	1.75	ØRstroke AUDE	1.12
Ø/stroke DFPB	1.102	Ø/SG/ABX2	1.72	Ø_ stroke_BU_M2_	1.75	ØRstroke AU--X	1.12
Ø/stroke DPB	1.102	Ø/SG/AX	1.50	Ø_ stroke_BU_M3_	1.75	ØRstroke CX/FM	1.57
Ø/stroke DVB	1.102	Ø/SG/AX2	1.50	Ø_ stroke_BU1_	1.75	ØRstroke CX_	1.57
Ø/stroke P_ _ _ _1	1.15	Ø/SG/BGB	1.88	Ø_ stroke_BU2_	1.75	ØRstroke DCB	1.102
Ø/stroke P_ _ _ _2	1.15	Ø/SG/BGM	1.88	Ø_ stroke_BU3_	1.75	ØRstroke DFAB	1.102
Ø/stroke P_ _ _ _3	1.15	Ø/SG/BU	1.75	Ø_ stroke_BUA_8	1.75	ØRstroke DFABC	1.102
Ø/stroke P_ _ _ _5	1.15	Ø/SG/BU2	1.75	Ø_ stroke_BUA_M_8	1.75	ØRstroke DPB	1.102
Ø/stroke P_ _ _ X	1.15	Ø/SG/BX	1.67	Ø_ stroke_CB_ _ _5	1.102	ØRstroke DVB	1.102
Ø/stroke PDC	1.15	Ø/SG/CPA/M	1.91	Ø_ stroke_CB_ _4	1.102	ØRstroke DVBC	1.102
Ø/stroke PDE	1.15	Ø/SG/CPU	1.63	Ø_ stroke_CB_1	1.102	ØRstroke PD_ X	1.15
Ø/stroke PSC	1.15	Ø/SG/CPU/FM	1.63	Ø_ stroke_CB_2	1.102	ØRstroke PDC	1.15
Ø/stroke PSE	1.15	Ø/SG/CPU2	1.63	Ø_ stroke_CB_3	1.102	ØRstroke PSC	1.15
Ø/stroke PYC	1.15	Ø/SG/CX	1.57	Ø_ stroke_FAB_ _ _5	1.102	ØRstroke PSE	1.15
Ø/stroke PYE	1.15	Ø/SG/CX/FM	1.57	Ø_ stroke_FAB_ _4	1.102	ØRstroke PYC	1.15
Ø/stroke SABX_	1.72	Ø/SG/CX2	1.57	Ø_ stroke_FAB_1	1.102	ØRstroke PYE	1.15
Ø/stroke SBX_	1.67	Ø/SG/CXL	1.57	Ø_ stroke_FAB_2	1.102	ØRstroke UD_ _ _Z	1.3
Ø/stroke SCB	1.102	Ø/SG/CXL/FM	1.57	Ø_ stroke_FAB_3	1.102	ØRstroke UD_ X	1.3
Ø/stroke SFAB	1.102	Ø/SG/CXL2	1.57	Ø_ stroke_FPB_ _ _5	1.102	ØRstroke UDC	1.3
Ø/stroke SFPB	1.102	Ø/SG/HB	1.102	Ø_ stroke_FPB_ _4	1.102	ØRstroke UDE	1.3
Ø/stroke SPB	1.102	Ø/SG/HB2	1.102	Ø_ stroke_FPB_1	1.102	ØRstroke USC	1.3
Ø/stroke SVB	1.102	Ø/SG/R/ABX	1.72	Ø_ stroke_FPB_2	1.102	ØRstroke USE	1.3
Ø/stroke U_ _ _ _2	1.3	Ø/SG/R/ABX2	1.72	Ø_ stroke_FPB_3	1.102	ØRstroke UYC	1.3
Ø/stroke U_ _ _ _Z	1.3	Ø/SG/R/AX	1.50	Ø_ stroke_PB_ _ _5	1.102	ØRstroke UYE	1.3
Ø/stroke U_ _ _ X	1.3	Ø/SG/R/AX2	1.50	Ø_ stroke_PB_ _4	1.102	ØRstroke_BX_	1.67
Ø/stroke UDC	1.3	Ø/SG/R/BU	1.75	Ø_ stroke_PB_1	1.102	ØRstroke AX	1.50
Ø/stroke UDE	1.3	Ø/SG/R/BU2	1.75	Ø_ stroke_PB_2	1.102	ØRstroke AX2	1.50
Ø/stroke USC	1.3	Ø/SG/R/BX	1.67	Ø_ stroke_PB_3	1.102	ØRstroke CPU	1.63
Ø/stroke USE	1.3	Ø/SG/R/CPU	1.63	Ø_ stroke_VB_ _ _5	1.102	ØRstroke CPU/FM	1.63
Ø/stroke UYC	1.3	Ø/SG/R/CPU/FM	1.63	Ø_ stroke_VB_ _4	1.102	ØRstroke X / _	1.21
Ø/stroke UYE	1.3	Ø/SG/R/CPU2	1.63	Ø_ stroke_VB_1	1.102	ØRstroke XL / _	1.29
Ø/stroke X/-	1.21	Ø/SG/R/CX	1.57	Ø_ stroke_VB_2	1.102	ØRstroke XT / _	1.25
Ø/stroke XL/-	1.29	Ø/SG/R/CX/FM	1.57	Ø_ stroke_VB_3	1.102	ØSstroke CX_	1.57
Ø/stroke XT/-	1.25	Ø/SG/R/CX2	1.57	ØC stroke PDC	1.15	ØSstroke CPU	1.63
Ø/stroke YABX_	1.72	Ø/SG/R/CXL	1.57	ØC stroke PDE	1.15	ØSstroke CPU/FM	1.63
Ø/stroke YBX_	1.67	Ø/SG/R/CXL/FM	1.57	ØstrokeX/_1	1.21	ØSstroke CX/FM	1.57
Ø/stroke YCB	1.102	Ø/SG/R/CXL2	1.57	ØstrokeX/_3	1.21	ØSstroke X / _	1.21
Ø/stroke YFAB	1.102	Ø/SG/R/HB	1.102	ØstrokeXL/_1	1.29	ØSstroke XL / _	1.29
Ø/stroke YFPB	1.102	Ø/SG/R/HB2	1.102	ØstrokeXL/_3	1.29	ØSstroke XT / _	1.25

ALPHANUMERIC INDEX

ITEM	PAGE	ITEM	PAGE	ITEM	PAGE	ITEM	PAGE
ØTstroke BX_	1.67	APTØ	1.20	C8/USAP/4	2.13	CEK8/3	2.62
ØTstroke CX/FM	1.57	AQB8N	3.22	C8/USAP/6	2.13	CEK8/5	2.62
ØTstroke CX_	1.57	AQB8R	3.22	C8/USAP/8	2.13	CK2/3	2.87
ØTstroke X/ _	1.21	AQB8V	3.22	C8/USASGG	2.12	CK2/5	2.87
ØTstroke XL/ _	1.29	AQF8N	3.22	C8/USCP/4	2.13	CK4/2	2.84
ØTstroke XT/ _	1.25	AQF8R	3.22	C8/USCP/6	2.13	CK4/3	2.84
ØVstroke 1 + stroke 2 CX_	1.57	AQF8V	3.22	C8/USCP/8	2.13	CK4/4	2.84
ØVstroke1+stroke2 BX_	1.67	AR8	3.20	C8/USCSGG	2.12	CK4/5	2.84
ØVstroke1+stroke2 BU_	1.75	ARN8	3.20	CA/SG/2	3.19	CK4/8	2.84
ØVstroke1+stroke2 BU_M_	1.75	AS2	3.20	CA/SG/4	3.19	CK8/2	2.81
ØVstroke1+stroke2 BU_M1_	1.75	AS4	3.20	CA/SG/8	3.19	CK8/3	2.81
ØVstroke1+stroke2 BU_M2_	1.75	AS8	3.20	CALR2	3.20	CK8/5	2.81
ØVstroke1+stroke2 BU_M3_	1.75	AT2	3.22	CALR4	3.20	CLR2	3.20
ØVstroke1+stroke2 BU1_	1.75	AT4	3.22	CALR8	3.20	CLR4	3.20
ØVstroke1+stroke2 BU2_	1.75	AT8	3.22	CALRN4	3.20	CLR8	3.20
ØVstroke1+stroke2 BU3_	1.75	AUDTØ	1.14	CALRN8	3.20	CLRN4	3.20
ØVstroke1+stroke2 X/ _	1.21	AUFØ	1.14	CALRU2	3.20	CLRN8	3.20
ØVstroke1+stroke2 XL/ _	1.29	AUPØ	1.14	CALRU4	3.20	CLRU2	3.20
ØVstroke1+stroke2 XT/ _	1.25	AUSCØ	1.14	CALRU8	3.20	CLRU4	3.20
ØYstroke CX/FM	1.57	AVL4	3.22	CAM2	3.24	CLRU8	3.20
ØYstroke CX_	1.57	AVL4F	3.22	CAM2F	3.24	CM2	3.22
ØYstroke CPU	1.63	AVL8	3.22	CAM4	3.24	CM2F	3.22
ØYstroke CPU/FM	1.63	AVL8F	3.22	CAM4/E	3.24	CM4	3.22
ØYstroke X/ _	1.21	AX/AS Ø	1.54	CAM4F	3.24	CM4/E	3.22
ØYstroke XL/ _	1.29	AX/ASSS Ø	1.55	CAM4F/E	3.24	CM4F	3.22
ØYstroke XT/ _	1.25	AX/CF Ø	1.53	CAM8	3.24	CM4F/E	3.22
A/ELP8M	2.16	AX/CFS Ø	1.54	CAM8/E	3.24	CM8	3.22
A/FFP10X1,25	1.108	AX/CM Ø	1.53	CAM8F	3.24	CM8/E	3.22
A/FFP12X1,25	1.108	AX/CMSS Ø	1.55	CAM8F/E	3.24	CM8F	3.22
A/FFP16X1,5	1.108	AX/CTA Ø	1.55	CAML4	3.24	CM8F/E	3.22
A/FFP20X1,5	1.108	AX/F Ø	1.52	CAML4F	3.24	CML4	3.22
A/FFP27X2	1.108	AX/PB Ø	1.52	CAML8	3.24	CML4F	3.22
A/FFP36X2	1.108	AX/SEC Ø	1.53	CAML8F	3.24	CML8	3.22
A/FFP6	1.108	AX/SEC Ø AT	1.54	CASS2	3.20	CML8F	3.22
A/FFP8	1.108	B/PB Ø	1.87	CASS4	3.20	CN/PR54	4.32
A/SG/2	3.19	BG/PF Ø	1.90	CASS8	3.20	CN/PR65	4.32
A/SG/4	3.19	BU/CF Ø	1.80	CAT2	3.24	CN1000	2.6
A/SG/8	3.19	BU/CF Ø AC	1.80	CAT4	3.24	CN300	2.6
ALR2	3.20	BU/CM Ø	1.71	CAT8	3.24	CN500	2.6
ALR4	3.20	BU/CM Ø	1.79	CAVL4	3.24	CNT3	1.111
ALR8	3.20	BU/CM Ø AC	1.71	CAVL4F	3.24	CNT5	1.111
ALRN4	3.20	BU/CM Ø AC	1.79	CAVL8	3.24	CP4	3.28
ALRN8	3.20	BU/CTA Ø	1.71	CAVL8F	3.24	CP8	3.28
ALRU2	3.20	BU/CTA Ø	1.80	CCM2	3.24	CPA/F Ø	1.93
ALRU4	3.20	BU/F Ø	1.71	CCM2F	3.24	CPA/PB Ø	1.93
ALRU8	3.20	BU/F Ø	1.79	CCM4	3.24	CPU/CF Ø	1.65
AM2	3.22	BU/F Ø AC	1.71	CCM4/E	3.24	CPU/CM Ø	1.66
AM2F	3.22	BU/F Ø AC	1.79	CCM4F	3.24	CPU/CPUI/SEC Ø	1.34-1.66
AM4	3.22	BU/PB Ø	1.71	CCM4F/E	3.24	CPU/F Ø	1.65
AM4/E	3.22	BU/PB Ø	1.79	CCM8	3.24	CPU/P Ø	1.65
AM4F	3.22	C/ELP8M	2.16	CCM8/E	3.24	CPUI/AS Ø	1.35
AM4F/E	3.22	C/SG/2	3.19	CCM8F	3.24	CPUI/AS Ø AC	1.35
AM8	3.22	C/SG/4	3.19	CCM8F/E	3.24	CPUI/ASSS Ø AC	1.36
AM8/E	3.22	C/SG/8	3.19	CCML4	3.24	CPUI/CF Ø	1.34
AM8F	3.22	C/UEASGB	2.15	CCML4F	3.24	CPUI/CF Ø AC	1.34
AM8F/E	3.22	C/UEASVB	2.15	CCML8	3.24	CPUI/CFA Ø	1.33
AML4	3.22	C/UECSPB	2.15	CCML8F	3.22	CPUI/CFS Ø	1.35
AML4F	3.22	C/UECSVB	2.15	CCVL4	3.24	CPUI/CFS Ø AC	1.35
AML8	3.22	C/USASGP	2.14	CCVL4F	3.24	CPUI/CM Ø	1.34
AML8F	3.22	C/USASVP	2.14	CCVL8	3.24	CPUI/CM Ø AC	1.34
AP4	3.28	C/USCSGP	2.14	CCVL8F	3.24	CPUI/CMSS Ø	1.36
AP8	3.28	C/USCSVG	2.16	CEK4/2	2.69	CPUI/CMSS Ø AC	1.36
APFPØ	1.20	C/USCSVP	2.14	CEK4/3	2.69	CPUI/CTA Ø	1.36
APGØ	1.20	C4/USASGG	2.12	CEK4/5	2.69	CPUI/F Ø	1.33-1.93
APSCØ	1.20	C4/USCSGG	2.12	CEK8/2	2.62	CPUI/PB Ø	1.33-1.93

ALPHANUMERIC INDEX

ITEM	PAGE	ITEM	PAGE	ITEM	PAGE	ITEM	PAGE
CPUI/SCT Ø	1.37	DST48X2	1.110	EKA2 KR/ZQ	2.71	EKCA2 KR/TQ	2.71
CPUI/SEC Ø AT	1.35	DST6	1.110	EKA2 KUC/TQ	2.72	EKCA2 KR/ZQ	2.71
CQB8N	3.22	DST8	1.110	EKA2 KUC/ZQ	2.72	EKCA2 KUC/KUC	2.73
CQB8R	3.22	DSTI 10	1.110	EKA2 KUR/ZQ	2.72	EKCA2 KUC/TQ	2.73
CQB8V	3.22	DSTI 10x1,25	1.110	EKA4 KLC/TQ	2.66	EKCA2 KUC/ZQ	2.73
CQF8N	3.22	DSTI 12x1,25	1.110	EKA4 KLC/ZR	2.66	EKCA2 KUR/KUR	2.73
CQF8R	3.22	DSTI 20x1,5	1.110	EKA4 KLR/ZR	2.66	EKCA2 KUR/ZQ	2.73
CQF8V	3.22	DSTI 27x2	1.110	EKA4 KR/TQ	2.63	EKCA2 SLC/SLC	2.73
CR8	3.20	DSTI 36x2	1.110	EKA4 KR/ZR	2.63	EKCA2 SLR/SLR	2.73
CRN8	3.20	DSTI 4	1.110	EKA4 KUC/TQ	2.66	EKCA2 SR/SR	2.71
CS2	3.20	DSTI 6	1.110	EKA4 KUC/ZR	2.66	EKCA2 SUC/SUC	2.73
CS4	3.20	DSTI 8	1.110	EKA4 KUR/ZR	2.66	EKCA2 SUR/SUR	2.73
CS8	3.20	EK/M/SG/4	3.6	EKA8 KLC/TQ	2.60	EKCA2/M	3.17
CT2	3.22	EK/M/SG/8	3.6	EKA8 KLC/ZR	2.60	EKCA2/MA	3.17
CT4	3.22	EK/SG/2	2.57	EKA8 KLR/ZR	2.60	EKCA2/MAF	3.17
CT8	3.22	EK/SG/4	2.57	EKA8 KR/TQ	2.58	EKCA2/MF	3.17
CVL4	3.22	EK/SG/8	2.57	EKA8 KR/ZR	2.58	EKCA2/MS	3.17
CVL4F	3.22	EK2 KLC/KLC	2.72	EKA8 KUC/TQ	2.60	EKCA2/MSF	3.17
CVL8	3.22	EK2 KLR/KLR	2.72	EKA8 KUC/ZR	2.60	EKCA30 ALC/ALC	2.70
CVL8F	3.22	EK2 KR/KR	2.71	EKA8 KUR/ZR	2.60	EKCA30 AUC/AUC	2.70
CX/AN Ø	1.62	EK2 KUC/KUC	2.72	EKA8/A	3.7	EKCA30 KLC/KLC	2.70
CX/AS Ø/SQ	1.62	EK2 KUR/KUR	2.72	EKA8/Q	3.7	EKCA30 KLC/TQ	2.70
CX/CF Ø	1.61	EK4 KLC/KLC	2.66	EKA8/TD	3.7	EKCA30 KLC/ZQ	2.70
CX/CPU/CT Ø	1.62-1.66	EK4 KLR/KLR	2.66	EKC2 KLC/TQ	2.72	EKCA30 KUC/KUC	2.70
CX/CPU/CT Ø	1.37	EK4 KR/KR	2.63	EKC2 KLC/ZQ	2.72	EKCA30 KUC/TQ	2.70
CX/CPU/CT Ø	1.62	EK4 KR/TR	2.63	EKC2 KLR/ZQ	2.72	EKCA30 KUC/ZQ	2.70
CX/F Ø	1.60	EK4 KUC/KUC	2.66	EKC2 KR/TQ	2.71	EKCA30 PLC/PLC	2.70
CX/FF10	1.110	EK4 KUR/KUR	2.66	EKC2 KR/ZQ	2.71	EKCA30 PUC/PUC	2.70
CX/FF16x1,5	1.110	EK4/LR	3.13	EKC2 KUC/TQ	2.72	EKCA30 SLC/SLC	2.70
CX/FF20x1,5	1.110	EK4/LRLR	3.13	EKC2 KUC/ZQ	2.72	EKCA30 SUC/SUC	2.70
CX/FF27x2	1.110	EK4/LRLRN	3.13	EKC2 KUR/ZQ	2.72	EKCA30/SG	2.70
CX/FFP10	1.110	EK4/LRN	3.13	EKC4 KLC/TQ	2.66	EKCA30/SG 5/3	2.70
CX/FFP16x1,5	1.110	EK4/M	3.15	EKC4 KLC/ZR	2.66	EKCA4 ALC/ALC	2.67
CX/FFP20x1,5	1.110	EK4/MF	3.15	EKC4 KLR/ZR	2.66	EKCA4 AR/AR	2.64
CX/FFP27x2	1.110	EK4/MV	3.15	EKC4 KR/TQ	2.63	EKCA4 AUC/AUC	2.67
CX/FFP36x2	1.110	EK4/MVF	3.15	EKC4 KR/ZR	2.63	EKCA4 AUR/AUR	2.67
CX/FM10	1.110	EK4/PS	3.13	EKC4 KUC/TQ	2.66	EKCA4 KLC/KLC	2.67
CX/FM16x1,5	1.110	EK4/PSS	3.13	EKC4 KUC/ZR	2.66	EKCA4 KLC/TQ	2.67
CX/FM20x1,5	1.110	EK4/T	3.15	EKC4 KUR/ZR	2.66	EKCA4 KLC/ZR	2.67
CX/FM27x2	1.110	EK4/TF	3.15	EKC8 KLC/TQ	2.60	EKCA4 KLR/KLR	2.67
CX/FM36x2	1.110	EK8 KLC/KLC	2.60	EKC8 KLC/ZR	2.60	EKCA4 KLR/ZR	2.67
CX/P Ø	1.60	EK8 KLR/KLR	2.60	EKC8 KLR/ZR	2.60	EKCA4 KR/KR	2.64
CX/PB Ø	1.61	EK8 KR/KR	2.58	EKC8 KR/TQ	2.58	EKCA4 KR/TQ	2.64
CX/PL Ø	1.60	EK8 KR/TR	2.58	EKC8 KR/ZR	2.58	EKCA4 KR/TR	2.64
CX/SEC Ø	1.61	EK8 KUC/KUC	2.60	EKC8 KUC/TQ	2.60	EKCA4 KR/ZR	2.64
D3/15	3.30	EK8 KUR/KUR	2.60	EKC8 KUC/ZR	2.60	EKCA4 KUC/KUC	2.67
D3/2	3.30	EK8/LR	3.7	EKC8 KUR/ZR	2.60	EKCA4 KUC/TQ	2.67
D3/2B	3.30	EK8/LRLR	3.7	EKC8/A	3.7	EKCA4 KUC/ZR	2.67
D3/4	3.30	EK8/LRLRN	3.7	EKC8/Q	3.7	EKCA4 KUR/KUR	2.67
D3/4B	3.30	EK8/LRLRU	3.7	EKC8/TD	3.7	EKCA4 KUR/ZR	2.67
DMA ___ / voltage	2.2	EK8/LRN	3.7	EKCA/M/SG/2	3.6	EKCA4 PLC/PLC	2.67
DMC ___ / voltage	2.2	EK8/LRU	3.7	EKCA/M/SG/4	3.6	EKCA4 PLR/PLR	2.67
DMIP5/1	2.4	EK8/M	3.10	EKCA/M/SG/8	3.6	EKCA4 PR/PR	2.64
DMIPM5/ _	2.4	EK8/MF	3.10	EKCA/SG/2	2.57	EKCA4 PUC/PUC	2.67
DMP5/ _	2.4	EK8/MV	3.10	EKCA/SG/2 5/3	2.57	EKCA4 PUR/PUR	2.67
DS_	3.30	EK8/MVF	3.10	EKCA/SG/4	2.57	EKCA4 SLC/SLC	2.67
DST10	1.110	EK8/PS	3.7	EKCA/SG/4 5/3	2.57	EKCA4 SLR/SLR	2.67
DST10x1,25	1.110	EK8/PSS	3.7	EKCA/SG/8	2.57	EKCA4 SR/SR	2.64
DST12x1,25	1.110	EK8/SLF	3.11	EKCA/SG/8 5/3	2.57	EKCA4 SUC/SUC	2.67
DST16x1,5	1.110	EK8/T	3.10	EKCA2 KLC/KLC	2.73	EKCA4 SUR/SUR	2.67
DST20x1,5	1.110	EK8/TF	3.10	EKCA2 KLC/TQ	2.73	EKCA4/LR	3.13
DST27x2	1.110	EKA2 KLC/TQ	2.72	EKCA2 KLC/ZQ	2.73	EKCA4/LRLR	3.13
DST36x2	1.110	EKA2 KLC/ZQ	2.72	EKCA2 KLR/KLR	2.73	EKCA4/LRLRN	3.13
DST4	1.110	EKA2 KLR/ZQ	2.72	EKCA2 KLR/ZQ	2.73	EKCA4/LRN	3.13
DST42X2	1.110	EKA2 KR/TQ	2.71	EKCA2 KR/KR	2.71	EKCA4/M	3.15

ALPHANUMERIC INDEX

ITEM	PAGE	ITEM	PAGE	ITEM	PAGE	ITEM	PAGE
EKCA4/MA	3.15	ELO4	3.32	ERP8/_4SF15	4.26	EZF1/_RR_LCC/PM/SS	4.24
EKCA4/MAF	3.15	ELPG8S	2.15	ERP8/_4SF420	4.26	EZF2/_PM/SA	4.13
EKCA4/MF	3.15	ELPG8S/B/USBG/voltage	2.15	ERP8/_4SFN	4.26	EZF2/_PM/SM	4.13
EKCA4/MS	3.15	ELPG8S/BAG/USBG/voltage	2.15	ERP8/_4SFP	4.26	EZF2/_PM/SS	4.13
EKCA4/MSF	3.15	ELPG8S/BAV/USBG/voltage	2.15	ERP8/_AF15	4.26	EZF2/_RR_L/PM/SA	4.24
EKCA4/MV	3.15	ELPG8S/BP/USBG/voltage	2.15	ERP8/_AF420	4.26	EZF2/_RR_L/PM/SM	4.24
EKCA4/MVF	3.15	ELPP8S	2.14	ERP8/_AFN	4.26	EZF2/_RR_L/PM/SS	4.24
EKCA4/PS	3.13	ELPP8S/P/USB/voltage	2.14	ERP8/_AFP	4.26	EZF2/_RR_LCA/PM/SA	4.24
EKCA4/PSS	3.13	ELPP8S/PAG/USB/voltage	2.14	ERP8/_TF15	4.26	EZF2/_RR_LCA/PM/SM	4.24
EKCA4/T	3.15	ELPP8S/PAV/USB/voltage	2.14	ERP8/_TF420	4.26	EZF2/_RR_LCA/PM/SS	4.24
EKCA4/TF	3.15	ELSQ	3.33	ERP8/_TFN	4.26	EZF2/_RR_LCC/PM/SA	4.24
EKCA8 ALC/ALC	2.61	ELY4	3.33	ERP8/_TFP	4.26	EZF2/_RR_LCC/PM/SM	4.24
EKCA8 ALR/ALR	2.61	ENCA/SG/4	2.57	ES.../N	5.52	EZF2/_RR_LCC/PM/SS	4.24
EKCA8 AR/AR	2.59	ENCA4 ALC/ALC	2.68	EV1	2.110	EZF3/_/SM	4.13
EKCA8 AUC/AUC	2.61	ENCA4 ALR/ALR	2.68	EV12	2.110	EZF3/_/SS	4.13
EKCA8 AUR/AUR	2.61	ENCA4 AR/AR	2.65	EV16	2.110	EZF3/_PM/SM	4.13
EKCA8 KLC/KLC	2.61	ENCA4 AUC/AUC	2.68	EV2	2.110	EZF3/_PM/SS	4.13
EKCA8 KLC/TQ	2.61	ENCA4 AUR/AUR	2.68	EV3	2.110	EZF3/_RR_L/PM/SM	4.24
EKCA8 KLC/ZR	2.61	ENCA4 KLC/KLC	2.68	EV4	2.110	EZF3/_RR_L/PM/SS	4.24
EKCA8 KLR/KLR	2.61	ENCA4 KLC/TQ	2.68	EV6	2.110	EZF3/_RR_L/SM	4.24
EKCA8 KLR/ZR	2.61	ENCA4 KLC/ZR	2.68	EV8	2.110	EZF3/_RR_L/SS	4.24
EKCA8 KR/KR	2.59	ENCA4 KLR/KLR	2.68	EZ/SVG/P1	4.25	EZF3/_RR_LCA/PM/SM	4.24
EKCA8 KR/TQ	2.59	ENCA4 KLR/ZR	2.68	EZ/SVG/P2	4.25	EZF3/_RR_LCA/PM/SS	4.24
EKCA8 KR/TR	2.59	ENCA4 KR/KR	2.65	EZ/SVG/P3	4.25	EZF3/_RR_LCA/SM	4.24
EKCA8 KR/ZR	2.59	ENCA4 KR/TQ	2.65	EZ1/20	4.13	EZF3/_RR_LCA/SS	4.24
EKCA8 KUC/KUC	2.61	ENCA4 KR/TR	2.65	EZ1/40	4.13	EZF3/_RR_LCC/PM/SM	4.24
EKCA8 KUC/TQ	2.61	ENCA4 KR/ZR	2.65	EZ1/PM	4.13-4.19	EZF3/_RR_LCC/PM/SS	4.24
EKCA8 KUC/ZR	2.61	ENCA4 KUC/KUC	2.68	EZ1/SVG	4.25	EZF3/_RR_LCC/SM	4.24
EKCA8 KUR/KUR	2.61	ENCA4 KUC/TQ	2.68	EZ1/SVG/1	4.25	EZF3/_RR_LCC/SS	4.24
EKCA8 KUR/ZR	2.61	ENCA4 KUC/ZR	2.68	EZ1/SVG/2	4.25	EZL1/C	4.19
EKCA8 PLC/PLC	2.61	ENCA4 KUR/KUR	2.68	EZ2/20	4.13	EZL1PM	4.19
EKCA8 PLR/PLR	2.61	ENCA4 KUR/ZR	2.68	EZ2/40	4.13	EZL1PM/CA	4.19
EKCA8 PR/PR	2.59	ENCA4 PLC/PLC	2.68	EZ2/5	4.13	EZL1PM/CC	4.19
EKCA8 PUC/PUC	2.61	ENCA4 PR/PR	2.65	EZ2/SVG	4.25	EZL2/C	4.19
EKCA8 PUR/PUR	2.61	ENCA4 PUC/PUC	2.68	EZ2/SVG/1	4.25	EZL2PM	4.19
EKCA8 SLC/SLC	2.61	ENCA4 PUR/PUR	2.68	EZ3/20	4.13	EZL2PM/CA	4.19
EKCA8 SLR/SLR	2.61	ENCA4 SLC/SLC	2.68	EZ3/40	4.13	EZL2PM/CC	4.19
EKCA8 SR/SR	2.59	ENCA4 SR/SR	2.65	EZ3/5	4.13	EZL3	4.19
EKCA8 SUC/SUC	2.61	ENCA4 SUC/SUC	2.68	EZ3/PM	4.13-4.19	EZL3/C	4.19
EKCA8 SUR/SUR	2.61	ENCA4 SUR/SUR	2.68	EZ3/SVG	4.25	EZL3/CA	4.19
EKCA8/A	3.7	ENCA4/SG/4 5/3	2.57	EZ3/SVG/1	4.25	EZL3/CC	4.19
EKCA8/LR	3.7	ERP2/_4SF15	4.26	EZ3/SVG/2	4.25	EZL3PM	4.19
EKCA8/LRLR	3.7	ERP2/_4SF420	4.26	EZAP/R1	4.20	EZL3PM/CA	4.19
EKCA8/LRLRN	3.7	ERP2/_4SFN	4.26	EZAP/R2	4.20	EZL3PM/CC	4.19
EKCA8/LRLRU	3.7	ERP2/_4SFP	4.26	EZAP/R3	4.20	EZPA1/3	4.25
EKCA8/LRN	3.7	ERP2/_AF15	4.26	EZAP/U1	4.20	EZPA2/3	4.25
EKCA8/LRU	3.7	ERP2/_AF420	4.26	EZAP/U2	4.20	EZPA3/3	4.25
EKCA8/M	3.10	ERP2/_AFN	4.26	EZAP/U3	4.20	EZRR1/_	4.15
EKCA8/MA	3.10	ERP2/_AFP	4.26	EZAP1/SVG	4.25	EZRR1/_F_L/PM/SA	4.23
EKCA8/MAF	3.10	ERP2/_TF15	4.26	EZAP1/SVG/1	4.25	EZRR1/_F_L/PM/SM	4.23
EKCA8/MF	3.10	ERP2/_TF420	4.26	EZAP2/SVG	4.25	EZRR1/_F_L/PM/SS	4.23
EKCA8/MS	3.10	ERP2/_TFN	4.26	EZAP2/SVG/1	4.25	EZRR1/_F_LCA/PM/SA	4.23
EKCA8/MSF	3.10	ERP2/_TFP	4.26	EZAP3/SVG	4.25	EZRR1/_F_LCA/PM/SM	4.23
EKCA8/MV	3.10	ERP4/_4SF15	4.26	EZAP3/SVG/1	4.25	EZRR1/_F_LCA/PM/SS	4.23
EKCA8/MVF	3.10	ERP4/_4SF420	4.26	EZF1/_PM/SA	4.13	EZRR1/_F_LCC/PM/SA	4.23
EKCA8/PS	3.7	ERP4/_4SFN	4.26	EZF1/_PM/SM	4.13	EZRR1/_F_LCC/PM/SM	4.23
EKCA8/PSS	3.7	ERP4/_4SFP	4.26	EZF1/_PM/SS	4.13	EZRR1/_F_LCC/PM/SS	4.23
EKCA8/Q	3.7	ERP4/_AF15	4.26	EZF1/_RR_L/PM/SA	4.24	EZRR1/_F_PM/SA	4.17
EKCA8/SLF	3.11	ERP4/_AF420	4.26	EZF1/_RR_L/PM/SM	4.24	EZRR1/_F_PM/SM	4.17
EKCA8/T	3.10	ERP4/_AFN	4.26	EZF1/_RR_L/PM/SS	4.24	EZRR1/_F_PM/SS	4.17
EKCA8/TD	3.7	ERP4/_AFP	4.26	EZF1/_RR_LCA/PM/SA	4.24	EZRR1/SG/6	4.15
EKCA8/TF	3.10	ERP4/_TF15	4.26	EZF1/_RR_LCA/PM/SM	4.24	EZRR2/_	4.15
ELA4	3.32	ERP4/_TF420	4.26	EZF1/_RR_LCA/PM/SS	4.24	EZRR2/_F_L/PM/SA	4.23
ELM4	3.33	ERP4/_TFN	4.26	EZF1/_RR_LCC/PM/SA	4.24	EZRR2/_F_L/PM/SM	4.23
ELN4	3.33	ERP4/_TFP	4.26	EZF1/_RR_LCC/PM/SM	4.24	EZRR2/_F_L/PM/SS	4.23

ALPHANUMERIC INDEX

ITEM	PAGE	ITEM	PAGE	ITEM	PAGE	ITEM	PAGE
EZRR2/_F_LCA/PM/SA	4.23	FCP8	3.28	FM157E	1.112	HCLR4	3.20
EZRR2/_F_LCA/PM/SM	4.23	FCR8	3.20	FM157E/C	1.112	HCLR8	3.20
EZRR2/_F_LCA/PM/SS	4.23	FCRN8	3.20	FO	4.29	HCLRN4	3.20
EZRR2/_F_LCC/PM/SA	4.23	FCS4	3.20	FS125	1.115	HCLRN8	3.20
EZRR2/_F_LCC/PM/SM	4.23	FCS8	3.20	FS162	1.115	HCLRU2	3.20
EZRR2/_F_LCC/PM/SS	4.23	FF10x1,25	1.108	HALR2	3.20	HCLRU4	3.20
EZRR2/_F_PM/SA	4.17	FF10x1,25/SA	1.109	HALR4	3.20	HCLRU8	3.20
EZRR2/_F_PM/SM	4.17	FF10x1,25/SS	1.108	HALR8	3.20	HCM2	3.22
EZRR2/_F_PM/SS	4.17	FF12x1,25	1.108	HALRN4	3.20	HCM2F	3.22
EZRR2/SG/6	4.15	FF12x1,25/SA	1.109	HALRN8	3.20	HCM4	3.22
EZRR3/_	4.15	FF12x1,25/SS	1.108	HALRU2	3.20	HCM4/E	3.22
EZRR3/_F_/SM	4.17	FF16x1,5	1.108	HALRU4	3.20	HCM4F	3.22
EZRR3/_F_/SS	4.17	FF16x1,5/SA	1.109	HALRU8	3.20	HCM4F/E	3.22
EZRR3/_F_L/PM/SM	4.23	FF16x1,5/SS	1.108	HAM2	3.22	HCM8	3.22
EZRR3/_F_L/PM/SS	4.23	FF20x1,5	1.108	HAM2F	3.22	HCM8/E	3.22
EZRR3/_F_L/SM	4.23	FF20x1,5/SA	1.109	HAM4	3.22	HCM8F	3.22
EZRR3/_F_L/SS	4.23	FF20x1,5/SS	1.108	HAM4/E	3.22	HCM8F/E	3.22
EZRR3/_F_LCA/PM/SM	4.23	FF27x2/SA	1.109	HAM4F	3.22	HCML4	3.22
EZRR3/_F_LCA/PM/SS	4.23	FF27x2/SS	1.108	HAM4F/E	3.22	HCML4F	3.22
EZRR3/_F_LCA/SM	4.23	FF36X2/SA	1.109	HAM8	3.22	HCML8	3.22
EZRR3/_F_LCA/SS	4.23	FF36x2/SS	1.108	HAM8/E	3.22	HCML8F	3.22
EZRR3/_F_LCC/PM/SM	4.23	FF4	1.108	HAM8F	3.22	HCQB8N	3.22
EZRR3/_F_LCC/PM/SS	4.23	FF4/SS	1.108	HAM8F/E	3.22	HCQB8R	3.22
EZRR3/_F_LCC/SM	4.23	FF42X2/SS	1.108	HAML4	3.22	HCQB8V	3.22
EZRR3/_F_LCC/SS	4.23	FF48X2/SS	1.108	HAML4F	3.22	HCQF8N	3.22
EZRR3/_F_PM/SM	4.17	FF6	1.108	HAML8	3.22	HCQF8R	3.22
EZRR3/_F_PM/SS	4.17	FF6/SA	1.109	HAML8F	3.22	HCQF8V	3.22
EZRR3/SG/6	4.15	FF6/SS	1.108	HAQB8N	3.22	HCR8	3.20
EZS2/3	4.25	FF8	1.108	HAQB8R	3.22	HCRN8	3.20
EZT/F1/SA	4.13	FF8/SA	1.109	HAQB8V	3.22	HCS2	3.20
EZT/F1/SM	4.13	FF8/SS	1.108	HAQF8N	3.22	HCS4	3.20
EZT/F1/SS	4.13	FFP10x1,25	1.108	HAQF8R	3.22	HCS8	3.20
EZT/F2/PM/SA	4.13	FFP12x1,25	1.108	HAQF8V	3.22	HCT2	3.22
EZT/F2/PM/SM	4.13	FFP16x1,5	1.108	HAR8	3.20	HCT4	3.22
EZT/F2/PM/SS	4.13	FFP20x1,5	1.108	HARN8	3.20	HCT8	3.22
EZT/F3/SM	4.13	FFP27x2	1.108	HAS2	3.20	HCVL4	3.22
EZT/F3/SS	4.13	FFP36x2	1.108	HAS4	3.20	HCVL4F	3.22
EZT/L1	4.19	FFP42X2	1.108	HAS8	3.20	HCVL8	3.22
EZT/L1/SLA	4.19	FFP48X2	1.108	HAT2	3.22	HCVL8F	3.22
EZT/L1/SLC	4.19	FFP6	1.108	HAT4	3.22	HFCLR4	3.20
EZT/L2/PM	4.19	FFP8	1.108	HAT8	3.22	HFCLR8	3.20
EZT/L2/PM/SLA	4.19	FG/050	1.114	HAVL4	3.22	HFCLRN4	3.20
EZT/L2/PM/SLC	4.19	FG/051	1.114	HAVL4F	3.22	HFCLRN8	3.20
EZT/L3	4.19	FG/052	1.114	HAVL8	3.22	HFCLRU4	3.20
EZT/L3/SLA	4.19	FG/053	1.114	HAVL8F	3.22	HFCLRU8	3.20
EZT/L3/SLC	4.19	FG/054	1.114	HB/FF10	1.109	HFCR8	3.20
EZVL1	4.22	FG/055	1.114	HB/FF12	1.109	HFCRN8	3.20
EZVL2	4.22	FG/056	1.114	HB/FF14	1.109	HFCS4	3.20
EZVL3	4.22	FG/057	1.114	HB/FF16	1.109	HFCS8	3.20
EZVL1/SVG	4.25	FG/058	1.114	HB/FF18	1.109	HS/BF Ø	1.48
EZVL1/SVG/1	4.25	FG/059	1.114	HB/FF20	1.109	HS/BR Ø	1.48
EZVL2/SVG	4.25	FM100	1.111	HB/SEC Ø	1.103	HS/NP Ø	1.48
EZVL2/SVG/1	4.25	FM100/C	1.111	HCCM4	3.24	HS/PT Ø	1.48
EZVL3/SVG	4.25	FM100/EX 1GD	1.115	HCCM4/E	3.24	HS40/stroke LU1	1.43
EZVL3/SVG/1	4.25	FM100/EX 3GD	1.115	HCCM4F	3.24	HS40/stroke LU2	1.43
F1	1.115	FM100E	1.111	HCCM4F/E	3.24	HS40/stroke LU3	1.43
F2	1.115	FM100E/C	1.111	HCCM8	3.24	HS40/stroke LU4	1.43
F3	1.115	FM100EN	1.111	HCCM8/E	3.24	HS40/stroke PD1	1.43
F90	4.29	FM100EN/C	1.111	HCCM8F	3.24	HS40/stroke PD2	1.43
FCLR4	3.20	FM100N	1.111	HCCM8F/E	3.24	HS40/stroke PD3	1.43
FCLR8	3.20	FM100N/C	1.111	HCCML4	3.24	HS40/stroke PD4	1.43
FCLRN4	3.20	FM100R	1.111	HCCML4F	3.24	HS40/stroke PR1	1.43
FCLRN8	3.20	FM100R/C	1.111	HCCML8	3.24	HS40/stroke PR2	1.43
FCLRU4	3.20	FM157	1.112	HCCML8F	3.24	HS40/stroke PR3	1.43
FCLRU8	3.20	FM157/C	1.112	HCLR2	3.20	HS40/stroke PR4	1.43

ALPHANUMERIC INDEX

ITEM	PAGE	ITEM	PAGE	ITEM	PAGE	ITEM	PAGE
HS40/stroke PU1	1.43	KB/SK8/10	2.28	MASM5/L	3.2	MEKCA4 KURG/KURG	2.54
HS40/stroke PU2	1.43	KB/SK8/12	2.28	MAT1/8	3.3	MEKCA4 KURG/ZQ	2.54
HS40/stroke PU3	1.43	KB/SK8/14	2.28	MAT4	3.3	MEKCA4 PR/PR	2.51
HS40/stroke PU4	1.43	KB/SK8/16	2.28	MAT4/L	3.3	MEKCA4 PUC/PUC voltage	2.52
IFS1	1.113	KB/SK8/18	2.28	MATM5	3.3	MEKCA4 PUCG/PUCG	2.54
IFS2	1.113	KB/SK8/2	2.28	MATM5/L	3.3	MEKCA4 PUR/PUR voltage	2.52
KB/EK 4/10	2.69	KB/SK8/20	2.28	MCLR1/8	3.3	MEKCA4 PURG/PURG	2.54
KB/EK 4/12	2.69	KB/SK8/3	2.28	MCLR4	3.3	MEKCA4 SR/SR	2.51
KB/EK 4/14	2.69	KB/SK8/4	2.28	MCLR4/L	3.3	MEKCA4 SUC/SUC voltage	2.52
KB/EK 4/16	2.69	KB/SK8/5	2.28	MCLR5	3.3	MEKCA4 SUCG/SUCG	2.54
KB/EK 4/18	2.69	KB/SK8/6	2.28	MCLR5/L	3.3	MEKCA4 SUR/SUR voltage	2.52
KB/EK 4/2	2.69	KB/SK8/8	2.28	MCLR1/8	3.3	MEKCA4 SURG/SURG	2.54
KB/EK 4/20	2.69	KIT/A/SK8	2.29	MCLRU4	3.3	MEKCA8 AR/AR	2.47
KB/EK 4/3	2.69	KIT/IR/MEK4	2.56	MCLRU4/L	3.3	MEKCA8 AUC/AUC voltage	2.48
KB/EK 4/4	2.69	KIT/IR/MEK8	2.50	MCLRUM5	3.3	MEKCA8 AUR/AUR voltage	2.48
KB/EK 4/5	2.69	KIT/P/ENK	2.65	MCLRUM5/L	3.3	MEKCA8 KR/KR	2.47
KB/EK 4/6	2.69	KIT/PC/DM	2.4	MCP1/8	3.3	MEKCA8 KR/TQ	2.47
KB/EK 4/8	2.69	KIT/PC/DMI	2.4	MCP4	3.3	MEKCA8 KR/ZQ	2.47
KB/EK 8/10	2.62	KIT/PC/EK4	2.69	MCP4/L	3.3	MEKCA8 KUC/KUC voltage	2.48
KB/EK 8/12	2.62	KIT/PC/EK8	2.62	MCPM5	3.3	MEKCA8 KUC/TQ voltage	2.48
KB/EK 8/14	2.62	KIT/PC/MEK4	2.56	MCPM5/L	3.3	MEKCA8 KUCZQ voltage	2.48
KB/EK 8/16	2.62	KIT/PC/MEK8	2.50	MCS1/8	3.2	MEKCA8 KUR/KUR voltage	2.48
KB/EK 8/18	2.62	KIT/PC/SK8	2.29	MCS4	3.2	MEKCA8 KUR/ZQ voltage	2.48
KB/EK 8/2	2.62	KIT/PC/UL	2.11	MCS4/L	3.2	MEKCA8 PR/PR	2.47
KB/EK 8/20	2.62	KIT/PC/UM	2.7	MCS-CB2	3.5	MEKCA8 PUC/PUC voltage	2.48
KB/EK 8/3	2.62	KIT/UDP/ISO1	2.99	MCS-FBR	3.5	MEKCA8 PUR/PUR voltage	2.48
KB/EK 8/4	2.62	KIT/UDP/ISO2	2.99	MCS-FMR	3.5	MEKCA8 SR/SR	2.47
KB/EK 8/5	2.62	KIT/UDP/ISO3	2.99	MCS-LCB	3.5	MEKCA8 SUC/SUC voltage	2.48
KB/EK 8/6	2.62	M/HS	1.43	MCS-LCM	3.5	MEKCA8 SUR/SUR voltage	2.48
KB/EK 8/8	2.62	M/WBZ	1.7-1.38	MCS-LCSB	3.5	MEV/C	2.42
KB/MEK 4/10	2.56	M/WUG-WUGD	1.8-1.39	MCS-LCSM	3.5	MEV/C1	2.42
KB/MEK 4/12	2.56	M12G	4.29	MCSM5	3.2	MEV/C2	2.42
KB/MEK 4/14	2.56	M12L	4.29	MCSM5/L	3.2	MEV/CA/SG	2.30
KB/MEK 4/16	2.56	MA10/12	4.30	MCS-PMN	3.5	MEV/CC/SG	2.30
KB/MEK 4/18	2.56	MA4/1	4.30	MCS-PMR	3.5	MEV/CF10	2.42
KB/MEK 4/2	2.56	MA4/12	4.30	MCS-PMV	3.5	MEV/CF3	2.42
KB/MEK 4/20	2.56	MA4/4	4.30	MCT1/8	3.3	MEV/CF5	2.42
KB/MEK 4/3	2.56	MA4/6	4.30	MCT4	3.3	MEV/CP/SG	2.30
KB/MEK 4/4	2.56	MA5/1	4.30	MCT4/L	3.3	MEV/M2D/AC	2.42
KB/MEK 4/5	2.56	MA5/12	4.30	MCTM5	3.3	MEV/M2D/DC	2.42
KB/MEK 4/6	2.56	MA5/4	4.30	MCTM5/L	3.3	MEV/M2S/AC	2.42
KB/MEK 4/8	2.56	MA5/6	4.30	MEK/CA/SG/4	2.46	MEV/M2S/DC	2.42
KB/MEK 8/10	2.50	MA6/1	4.30	MEK/CA/SG/8	2.46	MEV/M4D/AC	2.42
KB/MEK 8/12	2.50	MA6/12	4.30	MEK/CC/SG/4	2.46	MEV/M4D/DC	2.42
KB/MEK 8/14	2.50	MA6/4	4.30	MEK/CC/SG/8	2.46	MEV/M4S/AC	2.42
KB/MEK 8/16	2.50	MA6/6	4.30	MEK/CP/SG/4	2.46	MEV/M4S/DC	2.42
KB/MEK 8/18	2.50	MALR1/8	3.3	MEK/CP/SG/8	2.46	MEV/PM	2.42
KB/MEK 8/2	2.50	MALR4	3.3	MEK/SG/4	2.46	MEV/SG	2.30
KB/MEK 8/20	2.50	MALR4/L	3.3	MEK/SG/8	2.46	MEV18 AR/AR	2.36
KB/MEK 8/3	2.50	MALRM5	3.3	MEK192/N	2.18	MEV18 AUC/AUC voltage	2.37
KB/MEK 8/4	2.50	MALRM5/L	3.3	MEK192/NLED voltage	2.18	MEV18 AUR/AUR voltage	2.37
KB/MEK 8/5	2.50	MALRU1/8	3.3	MEK192/NVD voltage	2.18	MEV18 KR/KR	2.36
KB/MEK 8/6	2.50	MALRU4	3.3	MEKCA4 AR/AR	2.51	MEV18 KR/TQ	2.36
KB/MEK 8/8	2.50	MALRU4/L	3.3	MEKCA4 AUC/AUC voltage	2.52	MEV18 KR/ZQ	2.36
KB/MEV 8/10	2.35	MALRUM5	3.3	MEKCA4 AUCG/AUCG	2.54	MEV18 KUC/KUC voltage	2.37
KB/MEV 8/12	2.35	MALRUM5/L	3.3	MEKCA4 AUR/AUR voltage	2.52	MEV18 KUC/TQ voltage	2.37
KB/MEV 8/14	2.35	MAP1/8	3.2	MEKCA4 AURG/AURG	2.54	MEV18 KUC/ZQ voltage	2.37
KB/MEV 8/16	2.35	MAP4	3.2	MEKCA4 KR/KR	2.51	MEV18 KUR/KUR voltage	2.37
KB/MEV 8/18	2.35	MAP4/L	3.2	MEKCA4 KR/ZQ	2.51	MEV18 KUR/ZQ voltage	2.37
KB/MEV 8/2	2.35	MAPM5	3.2	MEKCA4 KUC/KUC voltage	2.52	MEV18 PR/PR	2.36
KB/MEV 8/3	2.35	MAPM5/L	3.2	MEKCA4 KUC/ZQ voltage	2.52	MEV18 PUC/PUC voltage	2.37
KB/MEV 8/4	2.35	MAS1/8	3.2	MEKCA4 KUCG/KUCG	2.54	MEV18 PUR/PUR voltage	2.37
KB/MEV 8/5	2.35	MAS4	3.2	MEKCA4 KUCG/ZQ	2.54	MEV18 SR/SR	2.36
KB/MEV 8/6	2.35	MAS4/L	3.2	MEKCA4 KUR/KUR voltage	2.52	MEV18 SUC/SUC voltage	2.37
KB/MEV 8/8	2.35	MASM5	3.2	MEKCA4 KUR/ZQ voltage	2.52	MEV18 SUR/SUR voltage	2.37

ALPHANUMERIC INDEX

ITEM	PAGE	ITEM	PAGE	ITEM	PAGE	ITEM	PAGE
MEV18BM	2.40	MHALRM5/L	3.3	MR5/4	4.30	RG-DI-....	0,24
MEV18BS	2.40	MHALRU1/8	3.3	MR5/6	4.30	RG-DM-....	0,24
MEV18DG	2.40	MHALRU4	3.3	MR6/1	4.30	RG-GI-...	0,24
MEV18DP	2.40	MHALRU4/L	3.3	MR6/12	4.30	RG-O-....	0,24
MEV18PC	2.40	MHALRUM5	3.3	MR6/4	4.30	RG-P-....	0,24
MEV18PE	2.40	MHALRUM5/L	3.3	MR6/6	4.30	RG-TI-...	0,24
MEV18PUS	2.40	MHAP1/8	3.2	NB Ø	1.87	RO1-GM-...	5.13
MEV8 AR/AR	2.31	MHAP4	3.2	PCA4	3.28	RO1-GMG-...	5.14
MEV8 AUC/AUC voltage	2.32	MHAP4/L	3.2	PCA4/F	3.29	RO-2BSR-...	5.15
MEV8 AUR/AUR voltage	2.32	MHAPM5	3.2	PCA4M	3.29	RO-3BSR-...	5.16
MEV8 KR/KR	2.31	MHAPM5/L	3.2	PCA4M/F	3.29	RO-AC-...	5.20
MEV8 KR/TQ	2.31	MHAS1/8	3.2	PFØ	1.17	RO-ACL-...	5.20
MEV8 KR/ZQ	2.31	MHAS4	3.2	PGØ	1.17	RO-BD-...	5.16
MEV8 KUC/KUC voltage	2.32	MHAS4/L	3.2	PNP	4.31	RO-BDR-...	5.15
MEV8 KUC/TQ voltage	2.32	MHASM5	3.2	PNP4	3.28	RO-BS-...	5.16
MEV8 KUC/ZQ voltage	2.32	MHASM5/L	3.2	PNP4/F	3.28	RO-BSR-...	5.15
MEV8 KUR/KUR voltage	2.32	MHAT1/8	3.3	PNPCA4	3.28	RO-CBD-...	5.21
MEV8 KUR/ZQ voltage	2.32	MHAT4	3.3	PNPCA4/A	3.28	RO-CBS-...	5.21
MEV8 PR/PR	2.31	MHAT4/L	3.3	PNPCA4/AF	3.28	RO-CH-...	5.20
MEV8 PUC/PUC voltage	2.32	MHATM5	3.3	PNPCA4/F	3.28	RO-CT-...	5.21
MEV8 PUR/PUR voltage	2.32	MHATM5/L	3.3	PNPCA4/S	3.28	RO-DF-...	5.12
MEV8 SR/SR	2.31	MHCLR1/8	3.3	PNPCA4/SF	3.28	RO-DI-...	5.17
MEV8 SUC/SUC voltage	2.32	MHCLR4	3.3	PRA4	4.32	RO-DIR-...	5.17
MEV8 SUR/SUR voltage	2.32	MHCLR4/L	3.3	PRA8	4.32	RO-DIS-....	5.22
MEV8/PC	2.35	MHCLRM5	3.3	PRC4	4.32	RO-DM-....	5.12
MEV8/PF	2.35	MHCLRM5/L	3.3	PRC8	4.32	RO-E-....	5.19
MEVX18 AUC/AUC voltage	2.39	MHCLRU1/8	3.3	PRCA4	4.33	RO-GI-...	5.17
MEVX18 AUR/AUR voltage	2.39	MHCLRU4	3.3	PRCA8	4.33	RO-GM-...	5.13
MEVX18 KUC/KUC voltage	2.39	MHCLRU4/L	3.3	PRDA	4.31	RO-P-....	5.18
MEVX18 KUC/TQ voltage	2.39	MHCLRUM5	3.3	PSC Ø	1.17	RO-PF-...	5.18
MEVX18 KUC/ZQ voltage	2.39	MHCLRUM5/L	3.3	PT Ø	1.17	RO-R-....	5.19
MEVX18 KUR/KUR voltage	2.39	MHCP1/8	3.2	RC1-DFM-...	5.43	RO-RC-...	5.23
MEVX18 KUR/ZQ voltage	2.39	MHCP4	3.2	RC1-DGM-...	5.44	RO-RD-...	5.22
MEVX18 PUC/PUC voltage	2.39	MHCP4/L	3.2	RC1-DM-...	5.36	RO-RF-...	5.23
MEVX18 PUR/PUR voltage	2.39	MHCPM5	3.2	RC1-G-...	5.38	RO-RFV-...	5.24
MEVX18 SUC/SUC voltage	2.39	MHCPM5/L	3.2	RC1-TC-...	5.39	RO-RV-...	5.23
MEVX18 SUR/SUR voltage	2.39	MHCS1/8	3.2	RC1-TL-...	5.40	RO-T-...	5.19
MEVX8 AUC/AUC voltage	2.34	MHCS4	3.2	RC-C-...	5.40	RO-TC-...	5.14
MEVX8 AUR/AUR voltage	2.34	MHCS4/L	3.2	RC-CBD-...	5.42	RO-TI-...	5.18
MEVX8 KUC/KUC voltage	2.34	MHCSM5	3.2	RC-CBF-...	5.42	RO-TL-...	5.14
MEVX8 KUC/TQ voltage	2.34	MHCSM5/L	3.2	RC-CBS-...	5.42	RO-VBD-...	5.22
MEVX8 KUC/ZQ voltage	2.34	MHCT1/8	3.3	RC-DF-...	5.37	RO-VBS-...	5.22
MEVX8 KUR/KUR voltage	2.34	MHCT4	3.3	RC-DFM-...	5.43	RRP/SG/6	4.11
MEVX8 KUR/ZQ voltage	2.34	MHCT4/L	3.3	RC-DGM-...	5.44	RRP4/1	4.11
MEVX8 PUC/PUC voltage	2.34	MHCTM5	3.3	RC-DI-...	5.37	RRP4/5	4.11
MEVX8 PUR/PUR voltage	2.34	MHCTM5/L	3.3	RC-DM-...	5.36	RRP4/7	4.11
MEVX8 SUC/SUC voltage	2.34	MP4/1	4.30	RC-DS-....	5.41	RS1-N-...	5.25
MEVX8 SUR/SUR voltage	2.34	MP4/12	4.30	RC-G-...	5.43	RS1-PM-...	5.35
MF10/12	4.30	MP4/4	4.30	RC-GF-...	5.38	RS1-PMF-...	5.27
MF4/1	4.30	MP4/6	4.30	RC-GG-...	5.38	RS1-RMF-...	5.26
MF4/12	4.30	MP5/1	4.30	RC-GI-...	5.39	RS-CF-...	5.32
MF4/4	4.30	MP5/12	4.30	RC-P-...	5.37	RS-GF-...	5.29
MF4/6	4.30	MP5/4	4.30	RC-RC-...	5.45	RS-GM-...	5.30
MF5/1	4.30	MP5/6	4.30	RC-RV-...	5.45	RS-GMF-...	5.29
MF5/12	4.30	MP6/1	4.30	RC-TG-...	5.39	RS-M-....	5.26
MF5/4	4.30	MP6/12	4.30	RC-TI-...	5.40	RS-MFFF-...	5.32
MF5/6	4.30	MP6/4	4.30	RC-VBD-....	5.41	RS-MR-...	5.28
MF6/1	4.30	MP6/6	4.30	RC-VBS-....	5.41	RS-N-....	5.25
MF6/12	4.30	MR10/12	4.30	RG1-DM-...	0,24	RS-PF-...	5.33
MF6/4	4.30	MR4/1	4.30	RG1GM-....	0,24	RS-PG-...	5.34
MF6/6	4.30	MR4/12	4.30	RG1-TC-...	0,24	RS-PL-...	5.27
MHALR1/8	3.3	MR4/4	4.30	RG1-TL-....	0,24	RS-PM-...	5.34
MHALR4	3.3	MR4/6	4.30	RG-AR-....	0,24	RS-PMF-...	5.27
MHALR4/L	3.3	MR5/1	4.30	RG-D-....	0,24	RS-RMF-...	5.26
MHALRM5	3.3	MR5/12	4.30	RG-DF-...	0,24	RS-TC-...	5.28

ALPHANUMERIC INDEX

ITEM	PAGE	ITEM	PAGE	ITEM	PAGE	ITEM	PAGE
RS-TCF-...	5.31	SKA815 KUC/TQ	2.22	U4/SM	3.31	UDP8M/10	2.106
RS-TF-...	5.30	SKA815 KUC/ZQ	2.22	U4/SM2	3.31	UDP8M/2	2.106
RS-TFE-...	5.29	SKA815 KUR/ZQ	2.22	U8	3.31	UDP8M/3	2.106
RS-TLF-...	5.32	SKA822 KUC/TQ	2.23	UCT Ø	1.6	UDP8M/4	2.106
RS-TM-...	5.31	SKA822 KUC/ZQ	2.23	UDP/ISO1/3M/L	2.98	UDP8M/5	2.106
RS-TMC-...	5.30	SKA822 KUR/ZQ	2.23	UDP/ISO1/4M/Q	2.98	UDP8M/6	2.106
RS-TML-...	5.31	SKC+A8 KR/ZR	2.20	UDP/ISO1/4MS/Q	2.98	UDP8M/7	2.106
RS-TMO-...	5.28	SKC+A815 KUC/ZR	2.24	UDP/ISO1/8MS/Q	2.98	UDP8M/8	2.106
RS-YCM-...	5.33	SKC+A815 KUR/ZR	2.24	UDP/ISO1/B4	2.97	UDP8M/9	2.106
RS-YF-...	5.33	SKC+A822 KUC/ZR	2.26	UDP/ISO1/B8	2.97	UDP8S	2.105
RT-C-...	5.8	SKC+A822 KUR/ZR	2.26	UDP/ISO1/PC	2.99	UDS/SG/05	2.102
RT-DF-...	5.3	SKC+C8 KR/ZR	2.20	UDP/ISO1/S4	2.97	UDS/SG/105	2.90
RT-DI-...	5.6	SKC+C815 KUC/ZR	2.24	UDP/ISO1/S8	2.97	UDS/SG/12	2.102
RT-DIR-...	5.7	SKC+C815 KUR/ZR	2.24	UDP/ISO1/T	2.99	UDS/SG/212	2.90
RT-DM-...	5.3	SKC+C822 KUC/ZR	2.26	UDP/ISO1-2	2.99	UDS/SG/35	2.102
RT-G-...	5.4	SKC+C822 KUR/ZR	2.26	UDP/ISO1BM	2.100	UDS05 KR/KR	2.103
RT-GG-...	5.5	SKC8 KR/TQ	2.20	UDP/ISO1D	2.100	UDS05 KR/KUC	2.104
RT-GI-...	5.7	SKC8 KR/ZQ	2.20	UDP/ISO1PE	2.100	UDS05 KR/KUR	2.104
RT-GL-...	5.4	SKC815 KUC/TQ	2.22	UDP/ISO1PT	2.100	UDS05 KR/TQ	2.103
RT-GMF-...	5.10	SKC815 KUC/ZQ	2.22	UDP/ISO1PU	2.100	UDS05 KR/TR	2.103
RT-MDL-...	5.6	SKC815 KUR/ZQ	2.22	UDP/ISO1PUI	2.100	UDS05 KR/ZR	2.103
RT-MT-...	5.9	SKC822 KUC/TQ	2.23	UDP/ISO1PUL	2.100	UDS05 KUC/KR	2.104
RT-MTD-...	5.9	SKC822 KUC/ZQ	2.23	UDP/ISO1PUS	2.100	UDS05 KUC/KUC	2.104
RT-MTL-...	5.6	SKC822 KUR/ZQ	2.23	UDP/ISO2/2M/L	2.98	UDS05 KUC/TQ	2.104
RT-P-...	5.10	SKCA/SG/8	2.19	UDP/ISO2/3M/Q	2.98	UDS05 KUC/TR	2.104
RT-RC-...	5.9	SKCA/SG/8 -5/3	2.19	UDP/ISO2/3MS/Q	2.98	UDS05 KUC/ZR	2.104
RT-RF-...	5.11	SKCA8 KR/KR	2.20	UDP/ISO2/B3	2.97	UDS05 KUR/KR	2.104
RT-RFL-...	5.11	SKCA8 KR/TQ	2.20	UDP/ISO2/B4	2.97	UDS05 KUR/KUR	2.104
RT-RFV-...	5.11	SKCA8 KR/TR	2.20	UDP/ISO2/BM	2.101	UDS05 KUR/TR	2.104
RT-TC-...	5.4	SKCA8 KR/ZQ	2.20	UDP/ISO2/PC	2.99	UDS05 KUR/ZR	2.104
RT-TI-...	5.7	SKCA8 SR/SR	2.20	UDP/ISO2/PE	2.101	UDS05 SR/SR	2.103
RT-TL-...	5.5	SKCA815 KUC/KUC	2.24	UDP/ISO2/PT	2.101	UDS05 SUC/SUC	2.104
RT-TM-...	5.10	SKCA815 KUC/ZQ	2.24	UDP/ISO2/PU	2.101	UDS05 SUR/SUR	2.104
RT-YI-...	5.8	SKCA815 KUR/KUR	2.24	UDP/ISO2/PUI	2.101	UDS05 TQ/KR	2.103
RT-YIR-...	5.8	SKCA815 KUR/ZQ	2.24	UDP/ISO2/PUL	2.101	UDS05 TQ/KUC	2.104
RT-YM-...	5.5	SKCA815 SUC/SUC	2.24	UDP/ISO2/PUS	2.101	UDS05 TR/KR	2.103
RX2	3.31	SKCA815 SUR/SUR	2.24	UDP/ISO2/S3	2.97	UDS05 TR/KUC	2.104
RX3	3.31	SKCA822 KUC/KUC	2.26	UDP/ISO2/S4	2.97	UDS05 TR/KUR	2.104
RX4	3.31	SKCA822 KUC/ZQ	2.26	UDP/ISO2/T	2.99	UDS05 ZR/KR	2.103
RX8	3.31	SKCA822 KUR/KUR	2.26	UDP/ISO2-3	2.99	UDS05 ZR/KUC	2.104
RX8/6	3.31	SKCA822 KUR/ZQ	2.26	UDP/ISO2D	2.100	UDS05 ZR/KUR	2.104
SC-...	5.52	SKCA822 SUC/SUC	2.26	UDP/ISO3/1M/L	2.98	UDS105 AR/AR	2.91
SFPR	4.31	SKCA822 SUR/SUR	2.26	UDP/ISO3/2M/Q	2.98	UDS105 AUJEC/AUJEC	2.92
Size /SG/WBZ	1.7-1.38	SP-...	5.52	UDP/ISO3/B2	2.97	UDS105 AUER/AUER	2.92
Size/ PM/WBZ	1.7-1.38	SQ32-40/A	1.114	UDP/ISO3/S2	2.97	UDS105 KR/KR	2.91
SK/SG/8	2.19	SQ32-40/EK	2.74	UDP/ISO3/T	2.99	UDS105 KR/TQ	2.91
SK/SG/8-2 x 32	2.19	SQ50-63/EK	2.74	UDP/ISODT 1-2	2.100	UDS105 KR/TR	2.91
SK8 KR/KR	2.20	SQ80-100/A	1.114	UDP2B	2.105	UDS105 KR/ZR	2.91
SK8 KR/TR	2.20	SQ80-100/EK	2.74	UDP2M/2	2.106	UDS105 KRP/KRP	2.91
SK815 KUC/KUC	2.22	SQB	1.113	UDP2M/3	2.106	UDS105 KUJEC/KUJEC	2.92
SK815 KUR/KUR	2.22	SQB12	1.113	UDP2M/4	2.106	UDS105 KUJEC/TQ	2.92
SK822 KUC/KUC	2.23	SQZ	1.113	UDP2M/5	2.106	UDS105 KUJEC/TR	2.92
SK822 KUR/KUR	2.23	SS-..	5.52	UDP2S	2.105	UDS105 KUJEC/ZR	2.92
SKA+A8 KR/ZR	2.20	ST102	1.114	UDP4B	2.105	UDS105 KUJER/KUJER	2.92
SKA+A815 KUC/ZR	2.24	ST34	1.114	UDP4M/10	2.106	UDS105 KUJER/TR	2.92
SKA+A815 KUR/ZR	2.24	ST3456	1.114	UDP4M/2	2.106	UDS105 KUJER/ZR	2.92
SKA+A822 KUC/ZR	2.26	ST56	1.114	UDP4M/3	2.106	UDS105 KUPC/KUPC	2.92
SKA+A822 KUR/ZR	2.26	ST80	1.114	UDP4M/4	2.106	UDS105 KUPC/TQ	2.92
SKA+C8 KR/ZR	2.20	STPR	4.32	UDP4M/5	2.106	UDS105 KUPC/TR	2.92
SKA+C815 KUC/ZR	2.24	T-PA-...	5.54	UDP4M/6	2.106	UDS105 KUPC/ZR	2.92
SKA+C815 KUR/ZR	2.24	T-PELD-...	5.55	UDP4M/7	2.106	UDS105 KUPR/KUPR	2.92
SKA+C822 KUC/ZR	2.26	T-PU-...	5.53	UDP4M/8	2.106	UDS105 KUPR/TR	2.92
SKA+C822 KUR/ZR	2.26	U1	3.31	UDP4M/9	2.106	UDS105 KUPR/ZR	2.92
SKA8 KR/TQ	2.20	U2	3.31	UDP4S	2.105	UDS105 PR/PR	2.91
SKA8 KR/ZQ	2.20	U4	3.31	UDP8B	2.105	UDS105 PUEC/PUEC	2.92

ALPHANUMERIC INDEX

ITEM	PAGE	ITEM	PAGE	ITEM	PAGE	ITEM	PAGE
UDS105 PUER/PUER	2.92	UDS212 SUPR/SUPR	2.94	UKA1	2.88	UKHA4/32	2.82
UDS105 PUPC/PUPC	2.92	UDS35 KR/KR	2.103	UKA1/U	2.89	UKHA4/32/U	2.83
UDS105 PUPR/PUPR	2.92	UDS35 KR/KUC	2.104	UKA2/20	2.85	UKHA8/12	2.78
UDS105 SR/SR	2.91	UDS35 KR/KUR	2.104	UKA2/20/U voltage	2.86	UKHA8/12/U voltage	2.80
UDS105 SUEC/SUEC	2.92	UDS35 KR/TQ	2.103	UKA2/40	2.85	UKHA8/25	2.78
UDS105 SUER/SUER	2.92	UDS35 KR/TR	2.103	UKA2/40/U	2.86	UKHA8/25/U	2.80
UDS105 SUPC/SUPC	2.92	UDS35 KR/ZR	2.103	UKA4/16	2.82	UKHC1	2.88
UDS105 SUPR/SUPR	2.92	UDS35 KUC/KR	2.104	UKA4/16/U voltage	2.83	UKHC1/U	2.89
UDS12 KR/KR	2.103	UDS35 KUC/KUC	2.104	UKA4/32	2.82	UKHC2/20	2.85
UDS12 KR/KUC	2.104	UDS35 KUC/TQ	2.104	UKA4/32/U	2.83	UKHC2/20/SA	2.85
UDS12 KR/KUR	2.104	UDS35 KUC/TR	2.104	UKA8/12	2.78	UKHC2/20/U voltage	2.86
UDS12 KR/TQ	2.103	UDS35 KUC/ZR	2.104	UKA8/12/U voltage	2.80	UKHC2/40	2.85
UDS12 KR/TR	2.103	UDS35 KUR/KR	2.104	UKA8/25	2.78	UKHC2/40/SA	2.85
UDS12 KR/ZR	2.103	UDS35 KUR/KUR	2.104	UKA8/25/U	2.80	UKHC2/40/U	2.86
UDS12 KUC/KR	2.104	UDS35 KUR/TR	2.104	UKC/12/SG/8	2.77	UKHC4/16	2.82
UDS12 KUC/KUC	2.104	UDS35 KUR/ZR	2.104	UKC/16/SG/4	2.77	UKHC4/16/SA	2.82
UDS12 KUC/TQ	2.104	UDS35 SR/SR	2.103	UKC/20/SG/2	2.77	UKHC4/16/U voltage	2.83
UDS12 KUC/TR	2.104	UDS35 SUC/SUC	2.104	UKC/25/SG/8	2.77	UKHC4/32	2.82
UDS12 KUC/ZR	2.104	UDS35 SUR/SUR	2.104	UKC/32/SG/4	2.77	UKHC4/32/SA	2.82
UDS12 KUR/KR	2.104	UDS35 TQ/KR	2.103	UKC/40/SG/2	2.77	UKHC4/32/U	2.83
UDS12 KUR/KUR	2.104	UDS35 TQ/KUC	2.104	UKC/SG/1	2.77	UKHC8/12	2.78
UDS12 KUR/TR	2.104	UDS35 TR/KR	2.103	UKC1	2.88	UKHC8/12/SA	2.78
UDS12 KUR/ZR	2.104	UDS35 TR/KUC	2.104	UKC1/U	2.89	UKHC8/12/T	2.78
UDS12 SR/SR	2.103	UDS35 TR/KUR	2.104	UKC2/20	2.85	UKHC8/12/U voltage	2.80
UDS12 SUC/SUC	2.104	UDS35 ZR/KR	2.103	UKC2/20/SA	2.85	UKHC8/25	2.78
UDS12 SUR/SUR	2.104	UDS35 ZR/KUC	2.104	UKC2/20/U voltage	2.86	UKHC8/25/SA	2.78
UDS12 TQ/KR	2.103	UDS35 ZR/KUR	2.104	UKC2/40	2.85	UKHC8/25/T	2.78
UDS12 TQ/KUC	2.104	UDSI/SG/3	2.90	UKC2/40/SA	2.85	UKHC8/25/U	2.80
UDS12 TR/KR	2.103	UDSI3 AR/AR	2.95	UKC2/40/U	2.86	ULARG/R voltage	2.8
UDS12 TR/KUC	2.104	UDSI3 AU/EC/AU/EC	2.96	UKC4/16	2.82	ULARV/R voltage	2.8
UDS12 TR/KUR	2.104	UDSI3 AU/ER/AU/ER	2.96	UKC4/16/SA	2.82	ULASG/R voltage	2.9
UDS12 ZR/KR	2.103	UDSI3 AU/PC/AU/PC	2.96	UKC4/16/U voltage	2.83	ULASG/RA voltage	2.9
UDS12 ZR/KUC	2.104	UDSI3 AU/PR/AU/PR	2.96	UKC4/32	2.82	ULASG/U voltage	2.9
UDS12 ZR/KUR	2.104	UDSI3 KR/KR	2.95	UKC4/32/SA	2.82	ULASV/R voltage	2.9
UDS212 AR/AR	2.93	UDSI3 KR/TQ	2.95	UKC4/32/U	2.83	ULASV/RA voltage	2.9
UDS212 AU/EC/AU/EC	2.94	UDSI3 KR/TR	2.95	UKC8/12	2.78	ULASV/U voltage	2.9
UDS212 AU/ER/AU/ER	2.94	UDSI3 KR/ZR	2.95	UKC8/12/SA	2.78	ULCRG/R voltage	2.8
UDS212 AU/PC/AU/PC	2.94	UDSI3 KU/EC/KU/EC	2.96	UKC8/12/T	2.78	ULCRV/R voltage	2.8
UDS212 AU/PR/AU/PR	2.94	UDSI3 KU/EC/TQ	2.96	UKC8/12/U voltage	2.80	ULCSG/R voltage	2.9
UDS212 KR/KR	2.93	UDSI3 KU/EC/TR	2.96	UKC8/25	2.78	ULCSG/RA voltage	2.9
UDS212 KR/TQ	2.93	UDSI3 KU/EC/ZR	2.96	UKC8/25/SA	2.78	ULCSG/U voltage	2.9
UDS212 KR/TR	2.93	UDSI3 KU/ER/KU/ER	2.96	UKC8/25/T	2.78	ULCSV/R voltage	2.9
UDS212 KR/ZR	2.93	UDSI3 KU/ER/TR	2.96	UKC8/25/U	2.80	ULCSV/RA voltage	2.9
UDS212 KU/EC/KU/EC	2.94	UDSI3 KU/ER/ZR	2.96	UKCA/SG/2	2.77	ULCSV/U voltage	2.9
UDS212 KU/EC/TQ	2.94	UDSI3 KU/PC/KU/PC	2.96	UKCA/SG/4	2.77	ULP8B/2	2.10
UDS212 KU/EC/TR	2.94	UDSI3 KU/PC/TQ	2.96	UKCA/SG/8	2.77	ULP8B/3	2.10
UDS212 KU/EC/ZR	2.94	UDSI3 KU/PC/TR	2.96	UKCA1	2.88	ULP8B/5	2.10
UDS212 KU/ER/KU/ER	2.94	UDSI3 KU/PC/ZR	2.96	UKCA1/U	2.89	ULP8S/2	2.10
UDS212 KU/ER/TR	2.94	UDSI3 KU/PR/KU/PR	2.96	UKCA2	2.85	ULP8S/3	2.10
UDS212 KU/ER/ZR	2.94	UDSI3 KU/PR/TR	2.96	UKCA2/SA	2.85	ULP8S/5	2.10
UDS212 KU/PC/KU/PC	2.94	UDSI3 KU/PR/ZR	2.96	UKCA2/U	2.86	ULR1B	2.18
UDS212 KU/PC/TQ	2.94	UDSI3 SR/SR	2.95	UKCA4	2.82	ULR1B/LED voltage	2.18
UDS212 KU/PC/TR	2.94	UDSI3 SUEC/SUEC	2.96	UKCA4/SA	2.82	ULR1B/VD voltage	2.18
UDS212 KU/PC/ZR	2.94	UDSI3 SU/ER/SU/ER	2.96	UKCA4/U	2.83	UM_SV_/_/_ / voltage	2.5
UDS212 KU/PR/KU/PR	2.94	UDSI3 SUPC/SUPC	2.96	UKCA8	2.78	UMP4-2/10	2.7
UDS212 KU/PR/TR	2.94	UDSI3 SUPR/SUPR	2.96	UKCA8/SA	2.78	UMP4-2/2	2.7
UDS212 KU/PR/ZR	2.94	UDT Ø	1.5	UKCA8/U	2.80	UMP4-2/3	2.7
UDS212 PU/EC/PU/EC	2.94	UF Ø	1.6	UKHA1	2.88	UMP4-2/4	2.7
UDS212 PU/ER/PU/ER	2.94	UKA/12/SG/8	2.77	UKHA1/U	2.89	UMP4-2/5	2.7
UDS212 PU/PC/PU/PC	2.94	UKA/16/SG/4	2.77	UKHA2/20	2.85	UMP4-2/6	2.7
UDS212 PU/PR/PU/PR	2.94	UKA/20/SG/2	2.77	UKHA2/20/U voltage	2.86	UMP4-2/7	2.7
UDS212 SR/SR	2.93	UKA/25/SG/8	2.77	UKHA2/40	2.85	UMP4-2/8	2.7
UDS212 SUEC/SUEC	2.94	UKA/32/SG/4	2.77	UKHA2/40/U	2.86	UMP4-2/9	2.7
UDS212 SU/ER/SU/ER	2.94	UKA/40/SG/2	2.77	UKHA4/16	2.82	UMP5/1	2.7
UDS212 SUPC/SUPC	2.94	UKA/SG/1	2.77	UKHA4/16/U voltage	2.83	UMPM5/10	2.7

ALPHANUMERIC INDEX

ITEM	PAGE	ITEM	PAGE	ITEM	PAGE	ITEM	PAGE
UMPM5/2	2.7	UZF4/_RR_LM/SS	4.9	W 105 4 B E3A	2.107	W 108 4 V E5A	2.109
UMPM5/3	2.7	UZF4/_RR_LM/TM	4.9	W 105 4 E E3A	2.107	WAIRSOL (1L)	4.5
UMPM5/4	2.7	UZF4/_RR_LM/TM/SS	4.9	W 105 4 V E3A	2.107	WAIRSOL HS(1L)	1.43
UMPM5/5	2.7	UZF4/_TM	4.2	W 105 5 B E3A	2.107	WB/SG/2	3.36
UMPM5/6	2.7	UZF4/_TM/SS	4.2	W 105 5 E E3A	2.107	WB/SG/4	3.36
UMPM5/7	2.7	UZL/SG/3	4.5	W 105 5 V E3A	2.107	WB/SG/8	3.36
UMPM5/8	2.7	UZL/SG/4	4.5	W 106 1 B E2A	2.108	WB2B	3.36
UMPM5/9	2.7	UZL/TM	4.5	W 106 1 E E2A	2.108	WB2U	3.36
UP Ø	1.6	UZL4	4.5	W 106 1 V E2A	2.108	WB4B	3.36
UPDT16	1.110	UZL4M	4.5	W 106 10 B E2A	2.108	WB4U	3.36
URE2	3.35	UZL4MPM	4.5	W 106 10 E E2A	2.108	WB8B	3.36
URE8	3.35	UZL4MTM	4.5	W 106 10 V E2A	2.108	WB8U	3.36
URF2/25	3.35	UZL4PM	4.5	W 106 11 B E2A	2.108	WE2A/voltage	2.109
URF4/10	3.35	UZL4TM	4.5	W 106 11 E E2A	2.108	WE3A/voltage	2.109
URF8/1	3.35	UZPR4	4.10	W 106 11 V E2A	2.108	WE5A/voltage	2.109
URF8/2	3.35	UZRR/SG/5	4.3	W 106 2 B E2A	2.108	WRF Ø/rotation angle	1.94
URF8/5	3.35	UZRRHS	4.10-4.25	W 106 2 E E2A	2.108	WRM Ø/rotation angle	1.94
URG2/25	3.35	UZRR/SG/6	4.3	W 106 2 V E2A	2.108	WUGB size/stroke	1.8-1.39
URG4/10	3.35	UZRRH4/_	4.3	W 106 3 B E2A	2.108	WUGCD size	1.11-1.41
URG8/1	3.35	UZRRM4/_	4.3	W 106 3 E E2A	2.108	WUGCP size	1.11-1.41
URG8/2	3.35	UZRRM4/_F_	4.4	W 106 3 V E2A	2.108	WUGDB size/stroke	1.8-1.39
URG8/5	3.35	UZRRM4/_F_/SS	4.4	W 106 4 B E2A	2.108	WUGDM size/stroke	1.8-1.39
URS2/9	3.35	UZRRM4/_F_L	4.8	W 106 4 E E2A	2.108	WUGM size/stroke	1.8-1.39
URS3/7	3.35	UZRRM4/_F_L/PM	4.8	W 106 4 V E2A	2.108	X/CG	1.24
URS4/5	3.35	UZRRM4/_F_L/PM/SS	4.8	W 106 5 B E2A	2.108	X/CP	1.24
URS8/3	3.35	UZRRM4/_F_L/SS	4.8	W 106 5 E E2A	2.108	X/CT Ø	1.37
USB/voltage	2.17	UZRRM4/_F_L/TM	4.8	W 106 5 V E2A	2.108	X/P/M3	1.24
USB-BA/voltage	2.17	UZRRM4/_F_L/TM/SS	4.8	W 106 6 B E2A	2.108	X/P/M4	1.24
USBG/voltage	2.17	UZRRM4/_F_LM	4.8	W 106 6 E E2A	2.108	XH4CM2	3.24
USBG2/voltage/EX	2.17	UZRRM4/_F_LM/PM	4.8	W 106 6 V E2A	2.108	XH4CM2F	3.24
USBG-BA/voltage	2.17	UZRRM4/_F_LM/PM/SS	4.8	W 106 7 B E2A	2.108	XH4CM4	3.24
USC Ø	1.6	UZRRM4/_F_LM/SS	4.8	W 106 7 E E2A	2.108	XH4CM4F	3.24
USR102/N9	2.18	UZRRM4/_F_LM/TM	4.8	W 106 7 V E2A	2.108	XH4CM8	3.24
USR102/N9LED voltage	2.18	UZRRM4/_F_LM/TM/SS	4.8	W 106 8 B E2A	2.108	XH4CM8F	3.24
USR102/N9VD voltage	2.18	UZRRM4/_F_PM	4.4	W 106 8 E E2A	2.108	XT/CPU/CT Ø	1.37
UZ/PM	4.2 - 4.5	UZRRM4/_F_PM/SS	4.4	W 106 8 V E2A	2.108	XT/CT Ø	1.37
UZ/SVG	4.10	UZRRM4/_F_TM	4.4	W 106 9 B E2A	2.108	XVB	2.11
UZ/SVG/1	4.10	UZRRM4/_F_TM/SS	4.4	W 106 9 E E2A	2.108	XVF/SG/4-5	3.37
UZ/SVG/2	4.10	UZVL/4	4.7	W 106 9 V E2A	2.108	XVF4	3.37
UZ/SVG/P	4.10	UZVL/SVG	4.10	W 107 1 B E3A	2.108	XVF5	3.37
UZ/TM/R	4.2	UZVL/SVG/1	4.10	W 107 1 E E3A	2.108	ZCL Ø	1.101
UZ/TM/R/SS	4.2	VC-01	3.31	W 107 1 V E3A	2.108	ZCS Ø	1.101
UZAP/A4	4.7	VC-02	3.31	W 107 2 B E3A	2.108	ZPB Ø	1.101
UZAP/R4	4.6	VC-03	3.31	W 107 2 E E3A	2.108	ZTI Ø	1.101
UZAP/SVG	4.10	VC-04	3.31	W 107 2 V E3A	2.108		
UZAP/SVG/1	4.10	VM1	2.112	W 107 3 B E3A	2.108		
UZAP/U4	4.6	VM15	2.112	W 107 3 E E3A	2.108		
UZF/SG/1	4.2	VM2	2.112	W 107 3 V E3A	2.108		
UZF/SG/2	4.2	VM3	2.112	W 107 4 B E3A	2.108		
UZF/SG/3	4.2	VM4	2.112	W 107 4 E E3A	2.108		
UZF/SG/3/SS	4.2	VM8	2.112	W 107 4 V E3A	2.108		
UZF/SG/4	4.2	VS1-MF-...	5.51	W 107 5 B E2A	2.108		
UZF4/_	4.2	VS-FF-...	5.51	W 107 5 E E2A	2.108		
UZF4/_/SS	4.2	VS-MF-...	5.51	W 107 5 V E2A	2.108		
UZF4/_PM	4.2	VSR-FF-...	5.50	W 107 6 B E2A	2.108		
UZF4/_PM/SS	4.2	VSR-MF...	5.50	W 107 6 E E2A	2.108		
UZF4/_RR_L	4.9	W 105 1 B E3A	2.107	W 107 6 V E2A	2.108		
UZF4/_RR_L/PM	4.9	W 105 1 E E3A	2.107	W 107 7 B E2A	2.108		
UZF4/_RR_L/PM/SS	4.9	W 105 1 V E3A	2.107	W 107 7 E E2A	2.108		
UZF4/_RR_L/SS	4.9	W 105 2 B E3A	2.107	W 107 7 V E2A	2.108		
UZF4/_RR_L/TM	4.9	W 105 2 E E3A	2.107	W 108 1 V E2A	2.109		
UZF4/_RR_L/TM/SS	4.9	W 105 2 V E3A	2.107	W 108 1 V E5A	2.109		
UZF4/_RR_LM	4.9	W 105 3 B E3A	2.107	W 108 2 V E2A	2.109		
UZF4/_RR_LM/PM	4.9	W 105 3 E E3A	2.107	W 108 2 V E5A	2.109		
UZF4/_RR_LM/PM/SS	4.9	W 105 3 V E3A	2.107	W 108 3 V E5A	2.109		

EVOLUTION IS IN THE AIR



ITALIAN PNEUMATIC
COMPONENTS
FOR INDUSTRIAL
AUTOMATION



Waircom M.B.S. S.p.A.
Via Piemonte, 13/15 - 20070 Vizzolo Predabissi (MILAN) ITALY
Tel: +39 02 98230821 - Fax: +39 02 98230830
www.waircom-mbs.com - info@waircom-mbs.com