

# Type EZL Pressure Reducing Regulator for Low Differential Pressure Applications

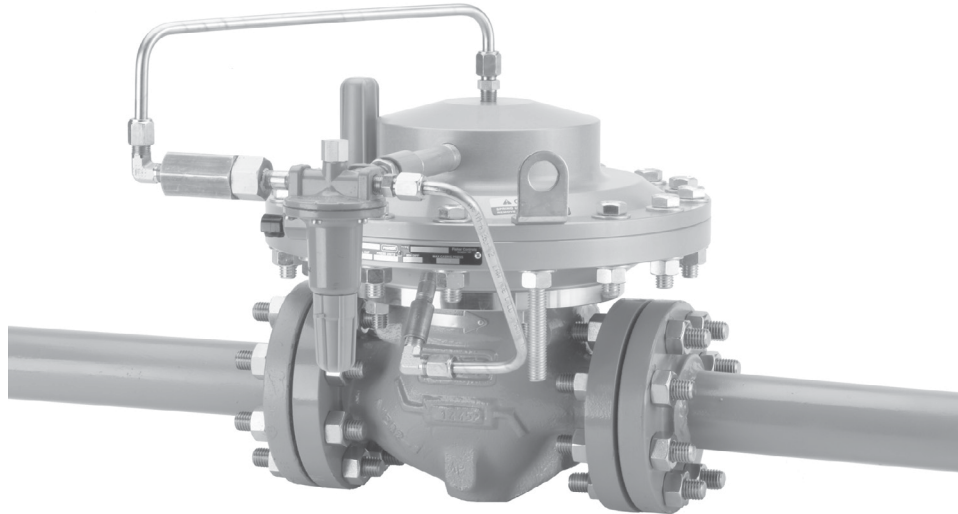

WB962\_1

Figure 1. Type EZL Pressure Reducing Regulator

## Features

- **Low Differential Applications**—Can accurately control at pressure differentials as low as 2.9 psid / 0.2 bar d.
- **Bubble-Tight Shutoff**—A knife-edged metal plug and soft seat provide bubble tight shutoff for use in applications where positive shutoff is required such as dead-end systems.
- **No Atmospheric Bleed**—Eliminates nuisance and wasteful bleed gas to atmosphere by utilizing a self-contained control system, which bleeds 100% of the gas to the downstream system.
- **Easy In-Line Maintenance**—The light-weight top entry design enables trim parts to be inspected, cleaned and replaced without removing the body from pipeline.
- **Precise Pressure Control**—Provides stable and accurate downstream pressure control regardless of inlet pressure variations or demand changes.
- **High Corrosion Resistance**—Anodized casings provide excellent corrosion resistance even in below-grade installations.
- **Full Pressure Rating**—The equal inlet and outlet pressure rating of 290 psig / 20 bar, which allows easier selection and requires no special startup or shutdown procedures.
- **Integral Slam Shut Configurations**—Type EZL-OSX discontinues gas service by shutting the gas off if there is an overpressure or underpressure condition.
- **High Turn Down Capability**—The oversized diaphragm and unique piloting system allow for high turn down, providing superior pressure control in systems with large variations in downstream flow demand.
- **Common Body Platform**—The Type EZL uses the same standard Fisher™ E-Body as the Types EZH and EZR pressure reducing regulators and Types EZ, ES, ED and ET pressure reducing control valves. This allows easy conversion from one product to another without the need to remove the E-Body from the pipeline.
- **Full Usable Capacity**—Fisher regulators are laboratory tested. 100% of the published flow capacity can be used with confidence.

# Type EZL

## Specifications

The Specifications section lists the specifications for Type EZL pressure reducing regulator. Factory specifications for specific regulator constructions are stamped on the nameplate fastened to either the main actuator or the pilot spring case.

### Body Sizes, End Connection Styles and Pressure Ratings<sup>(1)</sup>

See Table 1

### Maximum Inlet and Outlet (Casing) Pressures<sup>(1)</sup>

290 psig / 20.0 bar

### Maximum Emergency (Design Casing Pressure)<sup>(1)</sup>

290 psig / 20.0 bar

### Maximum Operating Differential Pressure<sup>(1)</sup>

290 psid / 20.0 bar d

### Minimum Differential Pressure<sup>(1)</sup>

TRIM, PERCENT OF CAPACITY	MINIMUM DIFFERENTIAL FOR FULL STROKE, psid / bar d		
	2 In. / DN 50	3 In. / DN 80	4 In. / DN 100
100	2.9 / 0.204	2.9 / 0.204	2.9 / 0.204
80	2.9 / 0.204	3.1 / 0.214	3.2 / 0.221
50	3.0 / 0.207	3.2 / 0.221	3.7 / 0.255
30	3.4 / 0.234	3.5 / 0.241	3.9 / 0.269

### Outlet Pressure Ranges

See Table 2

### Proportional Band Ranges

See Table 2

### IEC Sizing Coefficients

See Table 6

### Flow Coefficients

See Tables 7, 8, 9 and 10

### Flow Capacities

See Tables 11 and 12

### Pressure Registration

External

### Process Temperature Capabilities<sup>(1)</sup>

**Nitrile (NBR) version:** -20 to 180°F / -29 to 82°C

**Fluorocarbon (FKM) Version:** 0 to 180°F / -18 to 82°C

### Options

- Travel Indicator
- Integral Type OS2 Slam-shut Device
- Relief Size-reduction Trim

### Construction Materials

#### Type EZL Main Valve

*Main Body:* Cast iron or WCC Steel

*Intermediate Flange:* Steel

*Actuator Casings:* Anodized Forged Aluminum

### Construction Materials (continued)

#### Type EZL Main Valve (continued)

*Inlet and Outlet Plates:* Steel

*Diaphragm:* Nitrile (NBR) with PVC coating

*O-ring:* Nitrile (NBR) or Fluorocarbon (FKM)

*Seat:* Nitrile (NBR) or Fluorocarbon (FKM)

#### Type 6352, 6353, 6354L, 6354M or 6354H Pilot

*Body, Body Plug, Spring Case and Closing Cap:*

Aluminum (**standard**) or Stainless steel

*Control Spring:* Zinc-plated steel

*Bellows Assembly:* Nickel and stainless steel

*Body Plug and Closing Cap Gaskets:* Composition

*Other Metal Trim Parts:* Steel, Aluminum and/or

Stainless steel

*Diaphragm:* Nitrile (NBR) or Fluorocarbon (FKM)

*O-rings and Soft Parts:* Nitrile (NBR) (**standard**) or

Fluorocarbon (FKM)

#### 61 Series Pilots

*Body and Spring Case:* Cast iron

*Upper and Lower Diaphragm*

#### Type 61L: Nitrile (NBR) or Fluorocarbon (FKM)

#### Type 61HP: Neoprene (CR) or Fluorocarbon (FKM)

*Metal Trim Parts:* Steel, Stainless steel, Cast iron, Aluminum, Brass or Zinc

*Gasketing:* Neoprene (CR)

*Elastomer Seat and O-ring:* Nitrile (NBR) or Fluorocarbon (FKM)

#### Type 161EBM

*Body:* Stainless steel

*Spring Case:* Stainless steel

*Body Plug and Diaphragm Limiter:* Stainless steel

*Control Spring and Adjusting screw:* Plated steel

*Valve Plug, Diaphragm and O-ring:* Nitrile (NBR) or

Fluorocarbon (FKM)

#### Pilot and Actuator Vents

Type Y602 vent assembly

#### Type 252 Pilot Supply Filter

*Body:* Aluminum or Stainless steel

*Filter Cartridge:* Polyethylene

*O-ring:* Nitrile (NBR)

*Drain Valve or Pipe Plug:* Stainless steel

#### Type P590 Pilot Supply Filter

*Body and Filter Head:* Aluminum or Brass

*Filter Element:* Cellulose

1. The pressure/temperature limits in this Bulletin and any applicable standard or code limitation should not be exceeded.

## Introduction

Type EZL regulators are accurate pilot-operated, pressure balanced and soft seated regulators. They are designed for use in natural gas distribution applications such as district regulating stations and commercial/industrial meter sets. They provide low differential, smooth, reliable operation, tight shutoff and long life.

The Type EZL pressure reducing regulator includes a pilot mounted on the Type EZL main valve for pressure reducing, wide-open monitoring or working monitoring applications.

The Type EZL is also available with a slam-shut device for overpressure and/or underpressure protection.

## Principle of Operation

### Single-Pilot Regulator (Figures 2 and 3)

The pilot-operated Type EZL uses inlet pressure as the operating medium, which is reduced through pilot operation to load the actuator diaphragm. Outlet pressure opposes loading pressure in the actuator and also opposes the pilot control spring.

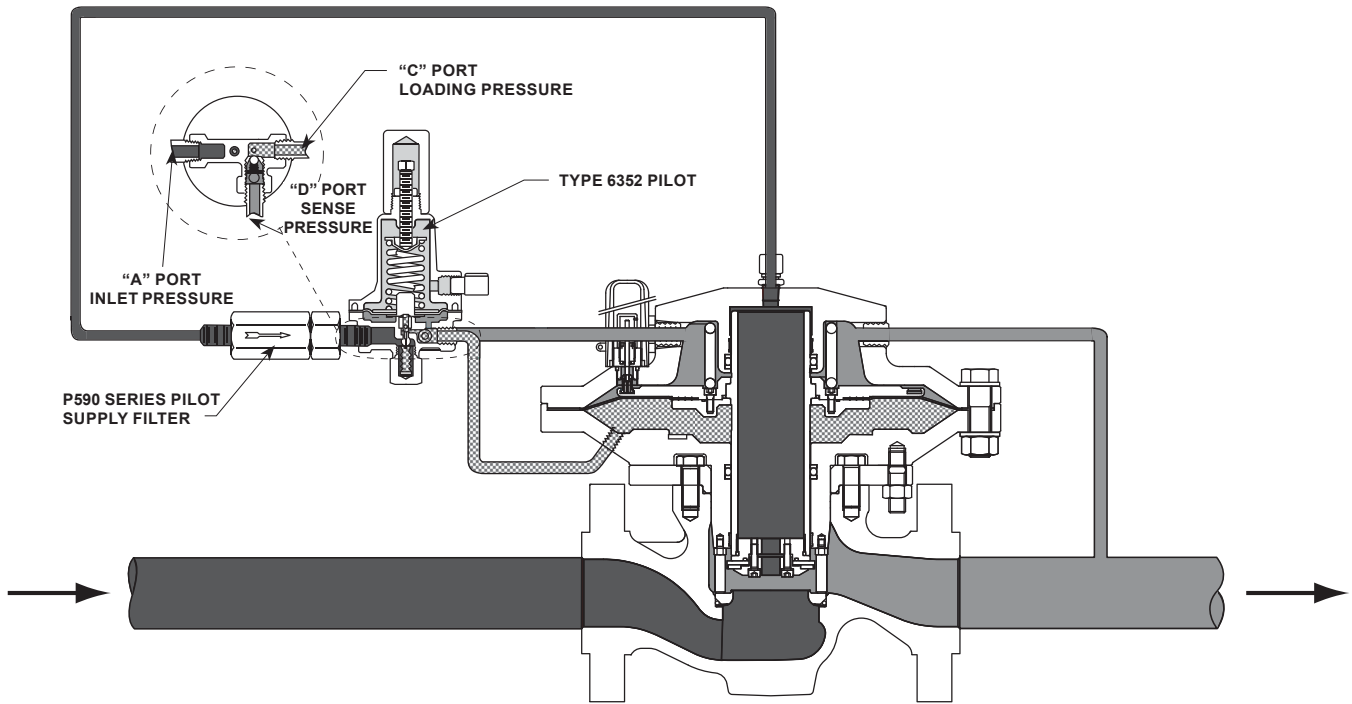

E0944\_06/2015

- INLET PRESSURE
- OUTLET PRESSURE
- ATMOSPHERIC PRESSURE
- LOADING PRESSURE

TYPE EZL MAIN VALVE

Figure 2. Principle of Operation for the Type EZL with Type 6352 Pilot

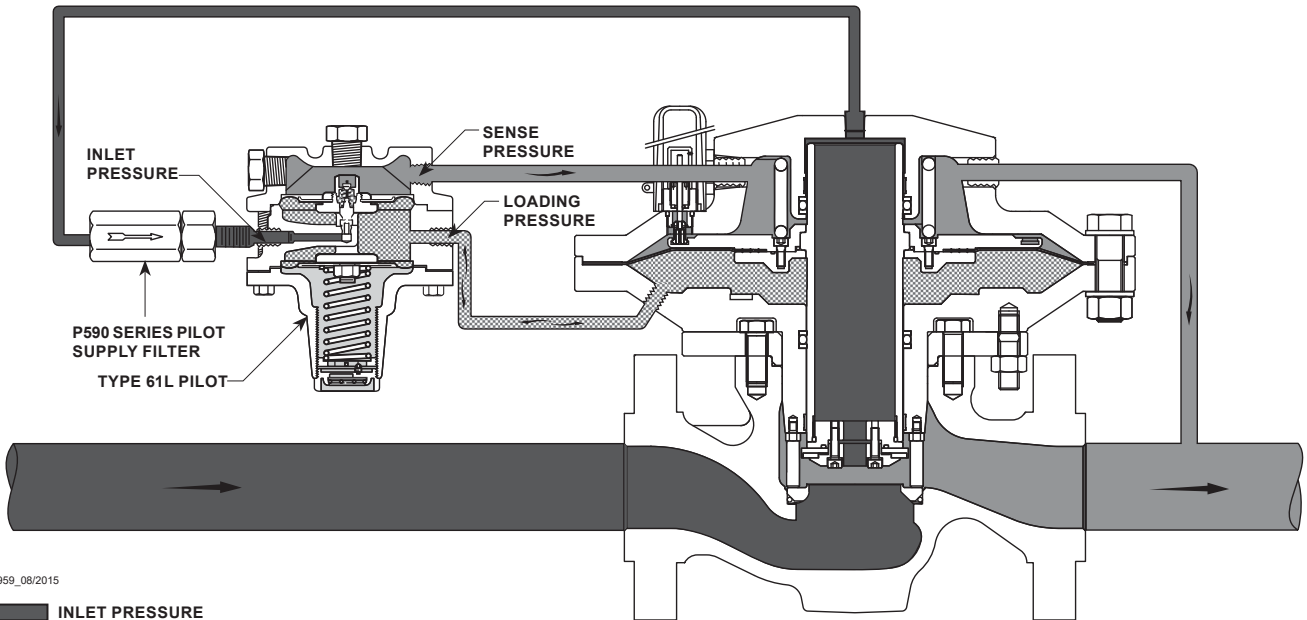

E0959\_08/2015

- INLET PRESSURE
- OUTLET PRESSURE
- ATMOSPHERIC PRESSURE
- LOADING PRESSURE

TYPE EZL MAIN VALVE

Figure 3. Principle of Operation for the Type EZL with Type 61L Pilot

# Type EZL

**Table 1. Main Valve Body Sizes, End Connection Styles and Body Ratings**

MAIN VALVE BODY SIZE	MAIN VALVE BODY MATERIAL	END CONNECTION STYLE	STRUCTURAL DESIGN RATING <sup>(1)</sup>	
			psig	bar
2, 3 and 4 in. / DN 50, 80 and 100	WCC Steel	NPT <sup>(2)</sup> or SWE <sup>(2)</sup>	1500	103
		CL150 RF	290	20.0
		CL300 RF	750	51.7
		CL600 RF or BWE	1500	103
	Cast Iron	NPT <sup>(2)</sup>	400	27.6
		CL125 FF	200	13.8

1. Structural Design Rating is the rating for the main valve body. The Type EZL complete assembly is limited to 290 psig / 20.0 bar.  
2. Only available in 2 in. / DN 50 body sizes.

**Table 2. Outlet (Control) Pressure Ranges**

PILOT TYPE	OUTLET (CONTROL) PRESSURE RANGE		SPRING COLOR	SPRING PART NUMBER	APPROXIMATE PROPORTIONAL BAND	
	psig	bar			psig	bar
6352	2 to 10	0.14 to 0.69	Black	14A9673X012	0.3	0.02
6353	3 to 40	0.21 to 2.8	Yellow	1E392527022	0.5	0.03
	35 to 125	2.41 to 8.6	Red	1K748527202	1.0	0.07
6354L <sup>(1)</sup> 6354M <sup>(2)</sup> 6354H <sup>(2)</sup>	85 to 200	5.9 to 13.8	Blue	1L346127142	3.0	0.2
	175 to 220	12.1 to 15.2	Blue	1L346127142	3.0	0.2
	200 to 300 <sup>(4)</sup>	13.8 to 20.7 <sup>(4)</sup>	Green	15A9258X012	5.0	0.3
61L	0.25 to 2	0.017 to 0.14	Red	1B886327022	0.15	0.01
	1 to 5	0.069 to 0.35	Yellow	1J857827022	0.2	0.01
	2 to 10	0.14 to 0.69	Blue	1B886427022	0.3	0.02
	5 to 15	0.35 to 1.03	Brown	1J857927142	0.5	0.03
	10 to 20	0.69 to 1.38	Green	1B886527022	0.7	0.05
61HP	15 to 45	1.03 to 3.10	Yellow	1E392527022	1.0	0.07
	35 to 100	2.41 to 6.90	Blue	1D387227022	1.5	0.1
	100 to 300 <sup>(4)</sup>	6.90 to 20.7 <sup>(4)</sup>	Red	1D465127142	3.0	0.2
161EBM <sup>(3)</sup>	5 to 15	0.34 to 1.03	White	17B1260X012	0.3	0.02
	10 to 40	0.69 to 2.8	Yellow	17B1262X012	0.5	0.03
	30 to 75	2.07 to 5.17	Black	17B1259X012	1.0	0.07
	70 to 140	4.83 to 9.65	Green	17B1261X012	2.0	0.14
	130 to 200	8.96 to 13.8	Blue	17B1263X012	4.0	0.28
	200 to 350 <sup>(4)</sup>	13.8 to 24.1 <sup>(4)</sup>	Red	17B1264X012	5.0	0.3

1. Without diaphragm limiter.  
2. With diaphragm limiter.  
3. Monitoring pilot for working monitors.  
4. Operating range is limited to maximum pressure.

When outlet pressure drops below the setting of the pilot control spring, pilot control spring force on the pilot diaphragm thus opens the pilot valve plug, providing additional loading pressure to the actuator diaphragm. This diaphragm loading pressure opens the main valve plug, supplying the required flow to the downstream system. Any excess loading pressure on the actuator diaphragm escapes downstream through the bleed restriction in the pilot.

When the gas demand in the downstream system has been satisfied, the outlet pressure increases. The increased pressure is transmitted through the downstream control line and acts on the pilot diaphragm. This pressure exceeds the pilot spring setting and moves the diaphragm, closing the orifice. The loading pressure acting on the main diaphragm bleeds to the downstream system through a bleed restriction in the pilot.

## Monitoring Systems

Monitoring regulation is overpressure protection by containment, therefore, there is no relief valve to vent to the atmosphere. When the working regulator fails to control the pressure, a monitor regulator installed in series, sensing the downstream pressure, goes into operation to maintain the downstream pressure at a slightly higher than normal pressure. During an

overpressure situation, monitoring keeps the customer on line. Also, testing is relatively easy and safe. To perform a periodic test on a monitoring regulator, increase the outlet set pressure of the working regulator and watch the outlet pressure to determine if the monitoring regulator takes over at the appropriate outlet pressure.

## Wide-Open Monitoring Systems (Figure 4)

There are two types of wide-open monitoring systems: upstream and downstream. The difference between upstream and downstream monitoring is that the functions of the regulators are reversed. Systems can be changed from upstream to downstream monitoring and vice-versa, by simply reversing the setpoints of the two regulators. The decision to use either an upstream or downstream monitoring system is largely a matter of personal preference or company policy.

In normal operation of a wide-open configuration, the working regulator controls the system's outlet pressure. With a higher outlet pressure setting, the monitor regulator senses a pressure lower than its setpoint and tries to increase outlet pressure by going wide-open. If the working regulator fails, the monitoring regulator assumes control and holds the outlet pressure at its outlet pressure setting.

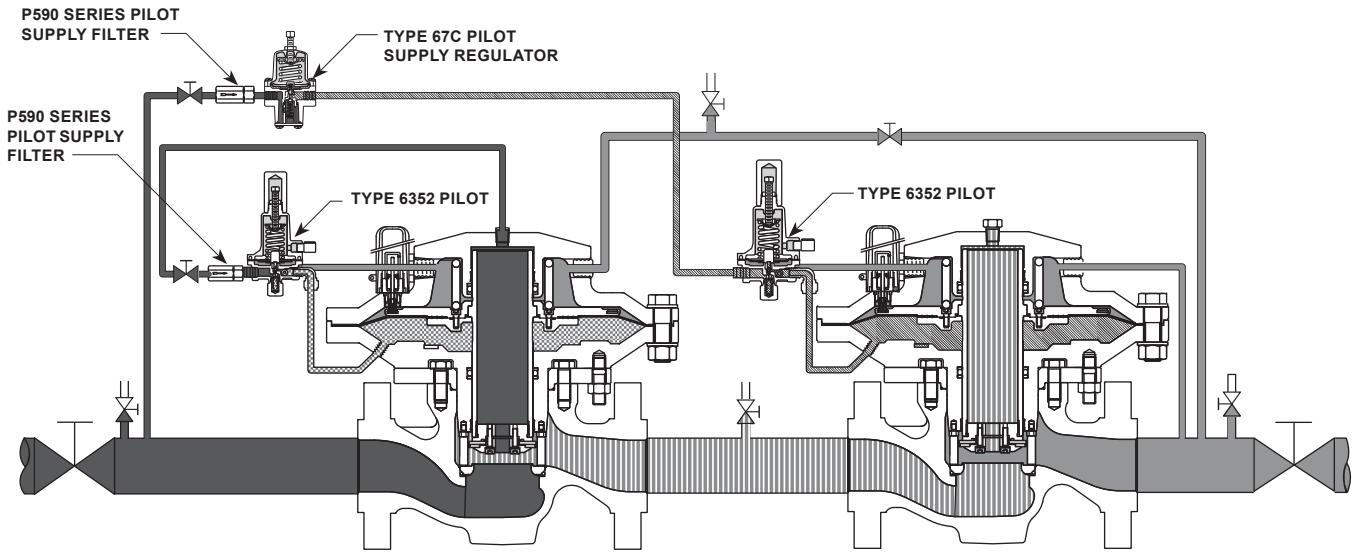

E0948\_11/2015

- INLET PRESSURE
- OUTLET PRESSURE
- LOADING PRESSURE
- ATMOSPHERIC PRESSURE
- INTERMEDIATE PRESSURE
- PILOT SUPPLY PRESSURE

TYPE EZL MAIN VALVE

TYPE EZL MAIN VALVE

Figure 4. Wide-Open Monitoring System Operational Schematic

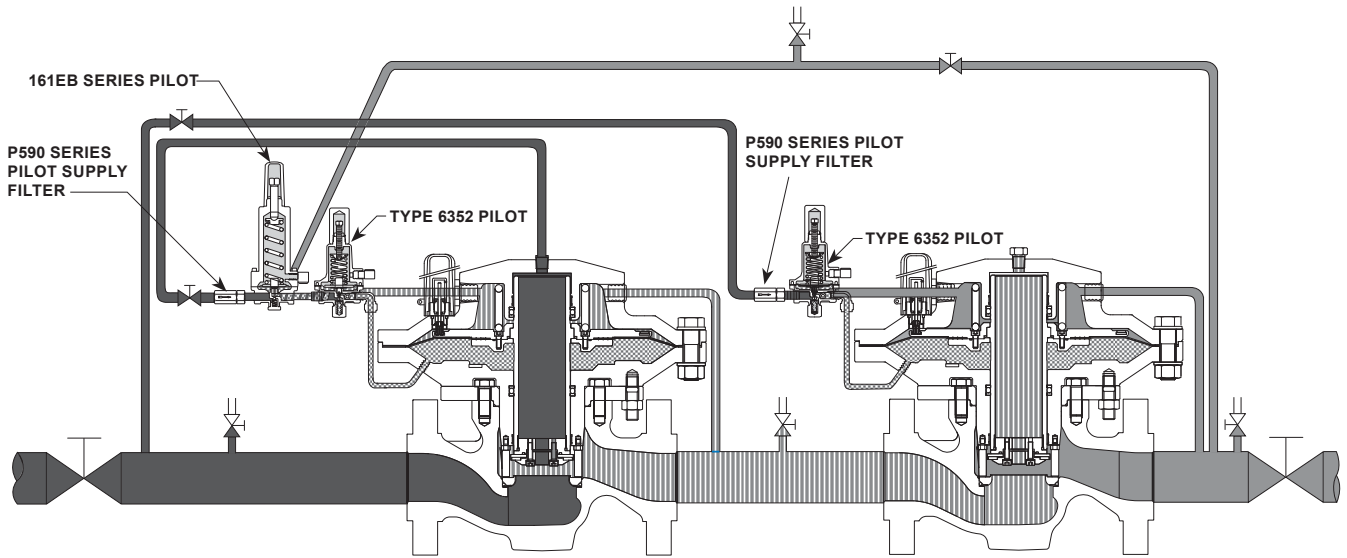

E0946\_08/2015

- INLET PRESSURE
- OUTLET PRESSURE
- LOADING PRESSURE
- ATMOSPHERIC PRESSURE
- INTERMEDIATE PRESSURE
- PILOT SUPPLY PRESSURE

TYPE EZL MAIN VALVE

TYPE EZL MAIN VALVE

Figure 5. Working Monitoring System Operational Schematic

# Type EZL

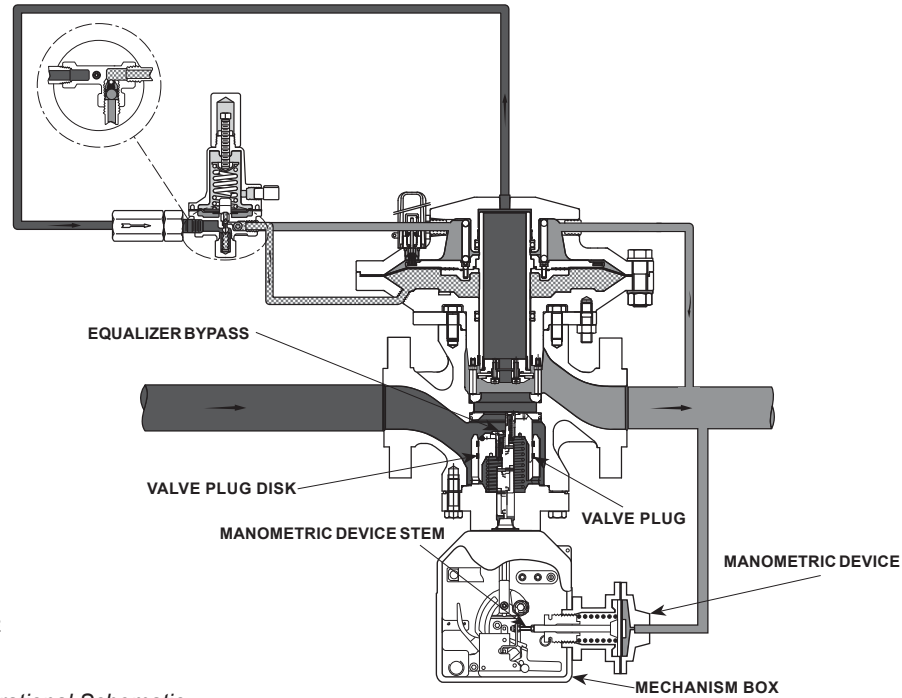

Figure 6. Type EZLOSX Operational Schematic

When using a 6350 Series pilot on the monitoring regulator, it should be equipped with a pilot supply regulator set to 5 psig / 0.34 bar plus the monitor minimum differential pressure above the working regulator pressure setting. Since the pilot on the monitoring regulator is wide-open during normal operation, the pilot supply regulator prevents differential check valve chatter on the monitoring regulator pilot.

## Working Monitoring Regulators (Figure 5)

In a working monitoring system, the upstream regulator requires two pilots and it is always the monitoring regulator. The additional pilot permits the monitoring regulator to act as a series regulator to control an intermediate pressure during normal operation. In this way, both units are always operating and can be easily checked for proper operation.

In normal operation, the working regulator controls the outlet pressure of the system. The monitoring regulator's working pilot controls the intermediate pressure and the monitoring pilot senses the system's outlet pressure. If the working regulator fails, the monitoring pilot will sense the increase in outlet pressure and take control.

Working monitor installations require a Type EZL main valve with a working pilot and a monitoring pilot for the upstream regulator and a Type EZL with the appropriate pilot for the downstream regulator.

## Pilot Descriptions

**Type 6352**—Outlet pressure range of 2 to 10 psig / 0.14 to 0.69 bar.

**Type 6353**—Outlet pressure range of 3 to 125 psig / 0.21 to 8.6 bar.

**Type 6354L**—Outlet pressure range of 85 to 200 psig / 5.9 to 13.8 bar.

**Type 6354M**—Outlet pressure range of 175 to 220 psig / 12.1 to 15.2 bar.

**Type 6354H**—Outlet pressure range of 200 to 290 psig / 13.8 to 20.0 bar.

**Type 61L**—Low pressure pilot for outlet pressure range of 0.25 to 20 psig / 0.02 to 1.38 bar.

**Type 61HP**—Extra high pressure pilot for outlet pressure range of 15 to 290 psig / 1.03 to 20.0 bar.

**Type 161EBM**—Outlet pressure range from 5 to 290 psig / 0.34 to 20.0 bar. The Type 161EBM is used as the monitor override pilot on working monitor applications.

## Slam-Shut Device Principle of Operation

The slam-shut device on the Type EZLOSX can provide either overpressure (OPSO) or overpressure (OPSO) and underpressure (UPS0) protection by completely shutting off the flow of gas to the downstream system. Pressure is registered on one side of the diaphragm, piston or bellows and is opposed by the setpoint control spring of the manometric sensing device. The Type OSX slam-shut valve tripping pressure is determined by the setting of the control spring.

**Overpressure:** when the downstream pressure increases above the setpoint, the pressure on top of the diaphragm overcomes the spring setting and moves the manometric device stem.

**Underpressure:** when the downstream pressure decreases below the setpoint, the control spring pressure below the diaphragm overcomes the downstream pressure and pushes the diaphragm which moves the manometric device stem.

**Table 3. Working Monitor Pilot Performance**

MONITORING PILOT INFORMATION					MINIMUM PRESSURE OVER NORMAL OUTLET PRESSURE AT WHICH WORKING MONITOR PILOT CAN BE SET	
MONITOR PILOT FOR WORKING MONITOR APPLICATION	OUTLET (CONTROL) PRESSURE RANGE		SPRING COLOR	SPRING PART NUMBER	psid	bar d
	psig	bar				
Type 161EBM	5 to 15	0.34 to 1.03	White	17B1260X012	3.0	0.2
	10 to 40	0.69 to 2.8	Yellow	17B1262X012	3.0	0.2
	30 to 75	2.07 to 5.17	Black	17B1259X012	3.0	0.2
	70 to 140	4.83 to 9.65	Green	17B1261X012	4.0	0.28
	130 to 200	8.96 to 13.8	Blue	17B1263X012	5.0	0.3
	200 to 350 <sup>(1)</sup>	13.8 to 24.1 <sup>(1)</sup>	Red	17B1264X012	5.0	0.3

1. Operating range is limited to maximum pressure.

**Table 4. Applications and Construction Guide (See Figure 7)**

APPLICATION	MECHANISM BOX REQUIRED	MANOMETRIC SENSING DEVICE REQUIRED	
Overpressure Shutoff (OPSO)	BM1	Type BMS1	----
Underpressure Shutoff (UPSO)		Type BMS1	----
Overpressure Shutoff (OPSO) and Underpressure Shutoff (UPSO)		Type BMS1	----
Overpressure Shutoff (OPSO) and Underpressure Shutoff (UPSO)	BM2	Type BMS1	Type BMS2
Overpressure Shutoff (OPSO), Overpressure Shutoff (OPSO) and Underpressure Shutoff (UPSO)		Type BMS1	Type BMS2

1. When using one manometric sensing device for both overpressure and underpressure shutoff, make sure that the difference between set pressures falls below the maximum range shown in Table 3.

2. When using a Type BMS1 and a Type BMS2, the Type BMS1 can only be used for high trip.

When the pressure of the downstream line rises above the set pressure (or drops below the set pressure) the manometric device senses the pressure change and triggers the detection stage which activates the second stage, releasing the slam-shut valve plug. Once the slam-shut device has been tripped, it must be manually reset.

## Installation

The Type EZL may be installed in any position, but is normally installed in a horizontal pipeline with the pilot or pilots above the body. See Figure 10 for typical piping installation.

## Capacity Information

### Note

**Type EZL flow capacities are laboratory verified; therefore, they may be sized for 100% flow using capacities as shown in Table 11. It is not necessary to reduce published capacities.**

Tables 11 and 12 show the natural gas regulating capacities of the Type EZL regulator at selected inlet pressures and outlet pressure settings. Flows are in thousands of SCFH at 60°F and 14.7 psia (and in thousands of Nm<sup>3</sup>/h at 0°C and 1.01325 bar) of 0.6 specific gravity natural gas. To determine equivalent capacities for air, propane, butane or nitrogen, multiply the capacity by the following appropriate conversion factor: 0.775 for air, 0.628 for propane, 0.548 for butane or 0.789 for nitrogen. For gases of other specific gravities, multiply the given capacity by 0.775 and divide by the square root of the appropriate specific gravity. Then, if capacity is desired in normal cubic meters per hour at 0°C and 1.01325 bar, multiply SCFH by 0.0268.

To find approximate regulating capacities at pressure settings not given in Tables 11 and 12 or to find wide-open flow capacities for relief sizing at any inlet pressure, perform one of the following procedures. Then, if necessary, convert using the factors provided above.

### Critical Pressure Drops

For critical pressure drops (absolute outlet pressure equal to or less than one-half of absolute inlet pressure), use the following formula:

$$Q = (P_1)(C_g)(1.29)$$

### Non-Critical Pressure Drops

For pressure drops lower than critical (absolute outlet pressure greater than one-half of absolute inlet pressure).

$$Q = \sqrt{\frac{520}{GT}} C_g P_1 \text{SIN} \left( \frac{3417}{C_1} \sqrt{\frac{\Delta P}{P_1}} \right) \text{DEG}$$

where,

Q = gas flow rate, SCFH

P<sub>1</sub> = absolute inlet pressure, psia (P<sub>1</sub> gauge + 14.7)

C<sub>g</sub> = regulating or wide-open gas sizing coefficient

G = gas specific gravity of the gas

T = absolute temperature of gas at inlet, °Rankine

C<sub>1</sub> = flow coefficient

ΔP = pressure drop across the regulator, psi

When sizing a working monitor setup, size each regulator separately using either the capacity tables or the equation method. When sizing a wide-open monitor setup, first use the equation method, solving for the pressure drop across the monitor at the maximum flow condition. Next size the worker using either the capacity tables or equation method while taking into account the monitor's maximum pressure drop.

# Type EZL

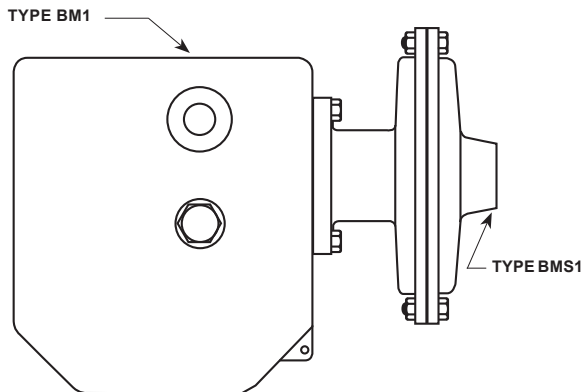

E0564

**MECHANISM BOX (TYPE BM1) WITH  
1 MANOMETRIC SENSING DEVICE (TYPE BMS1)**

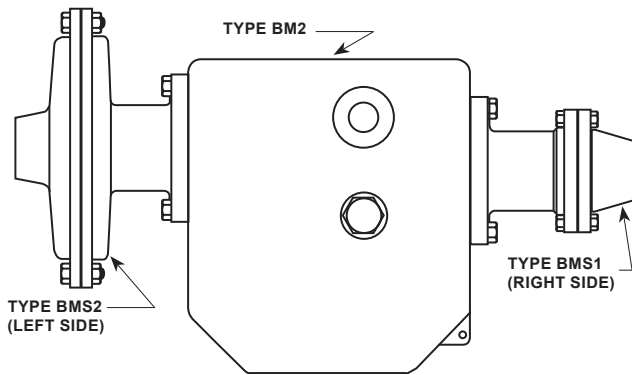

E0565

**MECHANISM BOX (TYPE BM2) WITH  
2 MANOMETRIC SENSING DEVICES (TYPES BMS1 AND BMS2)**

**Figure 7. Types of Slam-Shut Installation**

**Table 5. Spring Ranges, Part Numbers and Maximum and Minimum Pressures for Types BMS1 and BMS2**

SPRING RANGE	SPRING COLOR	SPRING PART NUMBER	MANOMETRIC SENSING DEVICE TYPE	MANOMETRIC SENSING DEVICE STYLE	MAXIMUM SENSING INLET PRESSURE, psig / bar	SETPOINT TOLERANCE, psig / bar <sup>(1)</sup>	MAXIMUM DIFFERENCE BETWEEN OVERPRESSURE AND UNDERPRESSURE, psig / bar <sup>(2)</sup>	SPRING WIRE DIAMETER, IN. / mm	SPRING FREE LENGTH, IN. / mm
4.02 to 14.1 in. w.c. / 10 to 35 mbar	Purple	FA113195X12	162	Diaphragm	74 / 5.1	1.61 in. w.c. / 4 mbar	4.02 in. w.c. / 10 mbar	0.080 / 2.03	2.36 / 59.9
9.97 to 33.2 in. w.c. / 25 to 83 mbar	Orange	FA113196X12				2.02 in. w.c. / 5 mbar	10 in. w.c. / 25 mbar	0.105 / 2.67	2.36 / 59.9
18 in. w.c. to 2.0 psig / 45 mbar to 0.14 bar	Red	FA113197X12				4.02 in. w.c. / 10 mbar	20.1 in. w.c. / 50 mbar	0.120 / 3.05	2.36 / 59.9
1.0 to 3.5 psig / 70 mbar to 0.24 bar	Yellow	FA113198X12				5.62 in. w.c. / 14 mbar	24.1 in. w.c. / 60 mbar	0.135 / 3.43	2.36 / 59.9
1.7 to 5.6 psig / 0.12 to 0.39 bar	Green	FA113199X12				7.23 in. w.c. / 18 mbar	2.18 / 0.15	0.156 / 3.96	2.36 / 59.9
2 to 11 psig / 0.14 to 0.76 bar	Gray	FA113201X12				20.1 in. w.c. / 50 mbar	5.08 / 0.35	0.192 / 4.88	2.36 / 59.9
4 to 19 psig / 0.28 to 1.3 bar	Brown	FA113202X12				1.16 / 80 mbar	8.70 / 0.60	0.207 / 5.26	2.36 / 59.9
7 to 33 psig / 0.48 to 2.3 bar	Black	FA114139X12				2.47 / 0.17	16.0 / 1.1	0.250 / 6.35	2.36 / 59.9
15 to 75 psig / 1.0 to 5.2 bar	Blue	FA113200X12	71		235 / 16.2	5.08 / 0.35	36.3 / 2.5	0.177 / 4.50	2.36 / 59.9
31 to 161 psig / 2.1 to 11.1 bar	Brown	FA113202X12				10.2 / 0.70	79.8 / 5.5	0.207 / 5.26	2.36 / 59.9
59 to 235 psig / 4.1 to 16.2 bar	Black	FA114139X12				23.2 / 1.6	145 / 10.0	0.250 / 6.35	2.36 / 59.9
235 to 290 psig / 16.2 to 20 bar	Brown	FA113202X12	27	Piston	1450 / 100	43.5 / 3.0	Requires use of Type BMS1 or BMS2	0.207 / 5.26	2.36 / 59.9

1. Minimum suggested difference between slam-shut set pressure and normal operating pressure of the system.

2. Maximum difference between overpressure and underpressure when using one manometric device (Type BMS1) with tripping hook. For underpressure and overpressure points greater than this maximum number, use a second manometric device (Type BMS2) for underpressure protection.



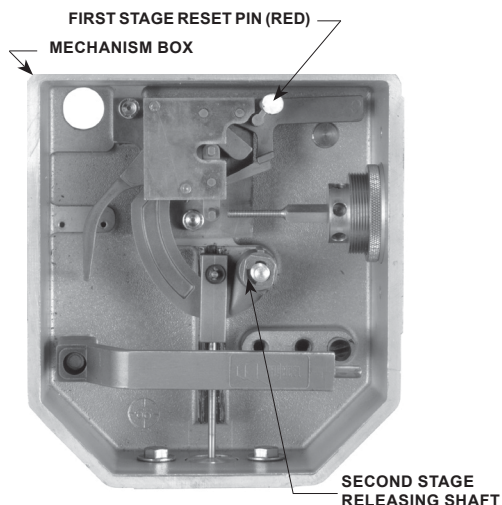

W8128\_1

**Figure 8.** Slam-Shut Device in Open Position

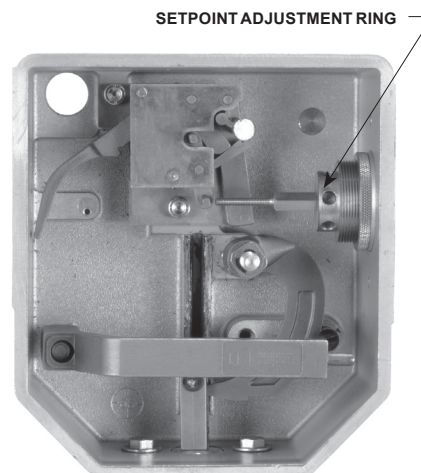

W8129\_1

**Figure 9.** Slam-Shut Device in Closed Position

**Table 6.** IEC Sizing Coefficients

MAIN VALVE BODY SIZE		TRIM, PERCENT OF CAPACITY	LINE SIZE EQUALS BODY SIZE		2:1 LINE SIZE TO BODY SIZE PIPING		F <sub>L</sub>
In.	DN		X <sub>T</sub>	F <sub>D</sub>	X <sub>T</sub>	F <sub>D</sub>	
2	50	100	0.829	0.61	0.766	0.60	0.89
		80	0.723	0.58	0.740	0.55	
		50	0.616	0.50	0.723	0.46	
		30	0.714	0.39	0.652	0.38	
3	80	100	0.710	0.61	0.660	0.60	
		80	0.685	0.55	0.676	0.55	
		50	0.788	0.42	0.706	0.43	
		30	0.770	0.34	0.660	0.35	
4	100	100	0.672	0.72	0.714	0.70	
		80	0.784	0.57	0.600	0.61	
		50	0.779	0.45	0.736	0.45	
		30	0.770	0.36	0.871	0.35	

**Table 7.** Type EZL Main Valve Regulating Flow Coefficients

MAIN VALVE BODY SIZE		TRIM, PERCENT OF CAPACITY	LINE SIZE EQUALS BODY SIZE			2:1 LINE SIZE TO BODY SIZE PIPING		
In.	DN		C <sub>g</sub>	C <sub>v</sub>	C <sub>i</sub>	C <sub>g</sub>	C <sub>v</sub>	C <sub>i</sub>
2	50	100	2290	63.2	36.2	2140	61.5	34.8
		80	1914	56.7	33.8	1760	51.5	34.2
		50	1290	41.4	31.2	1230	36.4	33.8
		30	858	25.5	33.6	800	24.9	32.1
3	80	100	4800	144	33.5	4580	142	32.3
		80	3950	120	32.9	3930	120	32.7
		50	2440	69.2	35.3	2420	72.5	33.4
		30	1560	44.8	34.9	1570	48.7	32.3
4	100	100	6560	200	32.6	6440	192	33.6
		80	4550	129	35.2	4500	146	30.8
		50	2740	78.2	35.1	2750	80.7	34.1
		30	1760	50.5	34.9	1760	47.4	37.1

**Table 8.** Type EZL Main Valve Wide-Open Flow Coefficients

MAIN VALVE BODY SIZE		TRIM, PERCENT OF CAPACITY	LINE SIZE EQUALS BODY SIZE			2:1 LINE SIZE TO BODY SIZE PIPING		
In.	DN		C <sub>g</sub>	C <sub>v</sub>	C <sub>i</sub>	C <sub>g</sub>	C <sub>v</sub>	C <sub>i</sub>
2	50	100	2360	65.0	37.3	2200	63.3	35.8
		80	1970	58.4	34.8	1810	53.0	35.2
		50	1330	42.6	32.1	1270	37.5	34.8
		30	884	26.3	34.7	820	25.7	33.1
3	80	100	4940	148	34.5	4710	146	33.3
		80	4060	123	33.9	4050	124	33.7
		50	2510	71.3	36.3	2500	74.7	34.5
		30	1610	46.1	35.9	1620	50.1	33.3
4	100	100	6760	208	33.5	6630	198	34.6
		80	4690	133	36.3	4630	151	31.7
		50	2830	80.5	35.2	2830	83.1	35.1
		30	1820	52.0	36.0	1810	48.7	38.2

# Type EZL

**Table 9. Type EZLOSX Main Valve Regulating Flow Coefficients**

MAIN VALVE BODY SIZE		TRIM, PERCENT OF CAPACITY	LINE SIZE EQUALS BODY SIZE			2:1 LINE SIZE TO BODY SIZE PIPING		
In.	DN		C <sub>g</sub>	C <sub>v</sub>	C <sub>i</sub>	C <sub>g</sub>	C <sub>v</sub>	C <sub>i</sub>
2	50	100	2210	65.7	33.6	2058	64.6	31.9
		80	1890	58.6	32.3	1790	56.6	31.6
		50 30	1270 855	43.2 26.6	29.5 32.1	1250 872	40.3 28.5	31.1 30.6
3	80	100	4610	134	34.5	4390	134	32.9
		80	4060	117	34.5	3900	118	33.1
		50 30	2600 1610	75.3 46.5	34.5 34.6	2420 1580	72.1 49.2	33.6 32.1
4	100	100	6280	194	32.4	6160	194	31.7
		80	4470	145	30.9	4380	141	31.1
		50 30	2740 1770	88.3 61.0	31.0 29.0	2700 1780	86.3 65.8	31.2 27.1

**Table 10. Type EZLOSX Main Valve Wide-Open Flow Coefficients**

MAIN VALVE BODY SIZE		TRIM, PERCENT OF CAPACITY	LINE SIZE EQUALS BODY SIZE			2:1 LINE SIZE TO BODY SIZE PIPING		
In.	DN		C <sub>g</sub>	C <sub>v</sub>	C <sub>i</sub>	C <sub>g</sub>	C <sub>v</sub>	C <sub>i</sub>
2	50	100	2280	67.7	34.6	2120	66.5	32.8
		80	1950	60.4	33.2	1840	58.3	32.6
		50 30	1310 881	44.5 27.4	30.4 33.1	1290 898	41.5 29.4	32.0 31.5
3	80	100	4750	138	35.5	4520	138	33.9
		80	4180	121	35.6	4020	121	34.1
		50 30	2680 1660	77.6 47.9	35.5 35.7	2490 1620	74.2 50.6	34.6 33.0
4	100	100	6470	200	33.4	6340	200	32.7
		80	4600	149	31.8	4500	145	32.1
		50 30	2820 1820	91.0 62.8	31.9 29.8	2780 1840	88.9 67.8	32.2 27.9

**Table 11. Capacities for Type EZL**

INLET PRESSURE		OUTLET PRESSURE		CAPACITIES IN THOUSANDS OF SCFH / Nm <sup>3</sup> /h OF 0.6 SPECIFIC GRAVITY NATURAL GAS USING 1:1 LINE SIZE TO BODY SIZE PIPING					
				2 in. / DN 50 Body		3 in. / DN 80 Body		4 in. / DN 100 Body	
psig	bar	psig	bar	SCFH	Nm <sup>3</sup> /h	SCFH	Nm <sup>3</sup> /h	SCFH	Nm <sup>3</sup> /h
4	0.3	0.25	0.02	37	1.00	83	2.22	116	3.10
		5	0.3	0.25 1 2	0.02 0.07 0.14	42 39 35	1.13 1.06 0.94	94 88 78	2.51 2.35 2.10
10	0.7	0.25	0.02	63	1.68	138	3.69	191	5.12
		3	0.21	56	1.51	124	3.33	173	4.64
		5	0.34	49	1.32	110	2.95	153	4.11
		7	0.48	40	1.06	89	2.39	124	3.34
15	1.0	1	0.07	79	2.13	173	4.64	239	6.41
		4	0.28	74	1.98	162	4.36	225	6.05
		8	0.55	63	1.69	140	3.75	195	5.23
		12	0.83	44	1.18	99	2.65	138	3.71
20	1.4	1	0.07	96	2.58	208	5.58	287	7.70
		10	0.69	79	2.13	175	4.71	244	6.55
		15	1.03	60	1.61	134	3.61	188	5.04
		17	1.17	48	1.28	107	2.88	150	4.04
30	2.1	4	0.28	126	3.37	271	7.26	372	10.0
		15	1.03	108	2.89	237	6.37	330	8.86
		20	1.38	93	2.49	206	5.54	288	7.73
		25	1.72	69	1.86	155	4.17	217	5.83
40	2.8	9	0.62	153	4.10	330	8.85	454	12.2
		20	1.38	136	3.64	298	8.00	414	11.1
		30	2.07	105	2.81	234	6.27	326	8.76
		35	2.41	77	2.07	174	4.66	243	6.53
50	3.4	13	0.90	181	4.86	391	10.5	538	14.4
		20	1.38	172	4.62	375	10.1	519	13.9
		30	2.07	152	4.07	335	8.99	466	12.5
		40	2.76	115	3.10	258	6.93	361	9.68
		45	3.10	85	2.27	190	5.11	267	7.16

- continued -

**Table 11. Capacities for Type EZL (continued)**

INLET PRESSURE		OUTLET PRESSURE		CAPACITIES IN THOUSANDS OF SCFH / Nm <sup>3</sup> /h OF 0.6 SPECIFIC GRAVITY NATURAL GAS USING 1:1 LINE SIZE TO BODY SIZE PIPING					
				2 in. / DN 50 Body		3 in. / DN 80 Body		4 in. / DN 100 Body	
psig	bar	psig	bar	SCFH	Nm <sup>3</sup> /h	SCFH	Nm <sup>3</sup> /h	SCFH	Nm <sup>3</sup> /h
60	4.1	17	1.17	209	5.62	451	12.1	622	16.7
		25	1.72	199	5.35	434	11.7	600	16.1
		35	2.41	180	4.83	397	10.6	551	14.8
		45	3.10	149	3.99	331	8.89	462	12.4
		55	3.79	91	2.45	206	5.52	288	7.73
75	5.2	24	1.65	251	6.73	541	14.5	745	20.0
		50	3.45	202	5.44	448	12.0	624	16.8
		60	4.14	165	4.44	370	9.92	516	13.9
		70	4.83	100	2.70	227	6.08	318	8.53
100	6.9	35	2.41	320	8.60	691	18.6	953	25.6
		60	4.14	280	7.52	617	16.6	856	23.0
		75	5.17	236	6.33	525	14.1	732	19.6
125	8.6	46	3.17	390	10.5	842	22.6	1160	31.1
		75	5.17	344	9.23	757	20.3	1051	28.2
150	10	57	3.93	460	12.3	992	26.6	1367	36.7
		75	5.17	436	11.7	951	25.5	1316	35.3
		100	6.89	383	10.3	847	22.8	1179	31.6
		125	8.62	291	7.82	652	17.5	911	24.5
175	12	68	4.69	530	14.2	1143	30.7	1574	42.3
		75	5.17	522	14.0	1129	30.3	1558	41.8
		100	6.89	482	12.9	1057	28.4	1465	39.3
		125	8.62	419	11.3	930	25.0	1296	34.8
		150	10.3	316	8.47	707	19.0	989	26.6
200	14	75	5.17	603	16.2	1300	34.9	1789	48.0
		100	6.89	572	15.4	1246	33.5	1723	46.3
		125	8.62	525	14.1	1155	31.0	1603	43.0
		150	10.3	453	12.2	1007	27.0	1404	37.7
		175	12.1	338	9.07	759	20.4	1062	28.5
225	16	75	5.17	683	18.3	1465	39.3	2013	54.0
		100	6.89	657	17.6	1424	38.2	1966	52.8
		125	8.62	619	16.6	1355	36.4	1877	50.4
		150	10.3	564	15.1	1246	33.4	1732	46.5
		175	12.1	484	13.0	1078	28.9	1504	40.4
		200	13.8	359	9.64	807	21.7	1130	30.3
250	17	75	5.17	761	20.4	1627	43.7	2232	59.9
		125	8.62	708	19.0	1541	41.4	2131	57.2
		150	10.3	663	17.8	1456	39.1	2021	54.2
		175	12.1	601	16.1	1331	35.7	1853	49.7
		200	13.8	513	13.8	1145	30.7	1599	42.9
		225	15.5	379	10.2	853	22.9	1194	32.1
285	20	75	5.17	869	23.3	1850	49.7	2534	68.0
		125	8.62	826	22.2	1789	48.0	2467	66.2
		150	10.3	791	21.2	1726	46.3	2388	64.1
		175	12.1	744	20.0	1635	43.9	2270	60.9
		200	13.8	681	18.3	1507	40.5	2098	56.3
		225	15.5	595	16.0	1327	35.6	1852	49.7

**Table 12. Capacities for Type EZLOSX**

INLET PRESSURE		OUTLET PRESSURE		CAPACITIES IN THOUSANDS OF SCFH / Nm <sup>3</sup> /h OF 0.6 SPECIFIC GRAVITY NATURAL GAS USING 1:1 LINE SIZE TO BODY SIZE PIPING					
				2 in. / DN 50 Body		3 in. / DN 80 Body		4 in. / DN 100 Body	
psig	bar	psig	bar	SCFH	Nm <sup>3</sup> /h	SCFH	Nm <sup>3</sup> /h	SCFH	Nm <sup>3</sup> /h
4	0.3	0.25	0.02	38	1.02	78	2.09	111	2.98
		0.25	0.02	43	1.15	88	2.36	125	3.37
5	0.3	1	0.07	40	1.08	82	2.21	118	3.16
		2	0.14	36	0.96	73	1.96	105	2.82
		0.25	0.02	63	1.70	130	3.49	183	4.92
10	0.7	3	0.21	57	1.53	117	3.14	166	4.46
		5	0.34	50	1.35	103	2.77	147	3.96
		7	0.48	41	1.10	83	2.23	120	3.21
		1	0.07	79	2.13	164	4.40	229	6.16
15	1.0	4	0.28	75	2.00	153	4.12	217	5.81
		8	0.55	64	1.72	131	3.53	188	5.03
		12	0.83	45	1.22	92	2.48	133	3.57
		1	0.07	96	2.57	198	5.30	275	7.38
20	1.4	10	0.69	81	2.16	165	4.43	235	6.30
		15	1.03	62	1.66	126	3.38	181	4.85
		17	1.17	49	1.32	100	2.70	145	3.89
		4	0.28	124	3.34	257	6.91	357	9.58
30	2.1	15	1.03	109	2.93	224	6.01	317	8.51
		20	1.38	95	2.55	194	5.21	277	7.43
		25	1.72	71	1.91	145	3.90	209	5.61

- continued -

# Type EZL

**Table 12. Capacities for Type EZLOSX (continued)**

INLET PRESSURE		OUTLET PRESSURE		CAPACITIES IN THOUSANDS OF SCFH / Nm <sup>3</sup> /h OF 0.6 SPECIFIC GRAVITY NATURAL GAS USING 1:1 LINE SIZE TO BODY SIZE PIPING					
				2 in. / DN 50 Body		3 in. / DN 80 Body		4 in. / DN 100 Body	
psig	bar	psig	bar	SCFH	Nm <sup>3</sup> /h	SCFH	Nm <sup>3</sup> /h	SCFH	Nm <sup>3</sup> /h
40	2.8	9	0.62	152	4.07	314	8.42	436	11.7
		20	1.38	137	3.68	281	7.55	398	10.7
		30	2.07	107	2.88	219	5.88	314	8.42
		35	2.41	80	2.14	162	4.36	234	6.28
50	3.4	13	0.90	180	4.82	371	9.97	516	13.8
		20	1.38	172	4.63	355	9.54	498	13.4
		30	2.07	154	4.13	315	8.47	448	12.0
		40	2.76	119	3.18	242	6.49	347	9.32
		45	3.10	87	2.35	178	4.77	257	6.89
60	4.1	17	1.17	208	5.57	429	11.5	596	16.0
		25	1.72	200	5.36	411	11.0	576	15.5
		35	2.41	182	4.89	374	10.0	529	14.2
		45	3.10	152	4.08	311	8.34	444	11.9
		55	3.79	94	2.53	192	5.16	277	7.45
75	5.2	24	1.65	249	6.68	514	13.8	715	19.2
		50	3.45	206	5.53	422	11.3	600	16.1
		60	4.14	170	4.56	346	9.30	497	13.3
		70	4.83	104	2.79	212	5.68	306	8.21
100	6.9	35	2.41	318	8.54	657	17.7	913	24.5
		60	4.14	283	7.61	582	15.6	823	22.1
		75	5.17	241	6.47	493	13.2	704	18.9
125	8.6	46	3.17	387	10.4	801	21.5	1112	29.9
		75	5.17	348	9.34	714	19.2	1009	27.1
150	10	57	3.93	456	12.3	944	25.3	1311	35.2
		75	5.17	437	11.7	901	24.2	1263	33.9
		100	6.89	389	10.5	798	21.4	1133	30.4
		125	8.62	299	8.04	611	16.4	877	23.5
175	12	68	4.69	526	14.1	1087	29.2	1510	40.5
		75	5.17	519	13.9	1072	28.8	1495	40.1
		100	6.89	486	13.0	999	26.8	1407	37.8
		125	8.62	427	11.5	875	23.5	1246	33.4
		150	10.3	325	8.72	662	17.8	952	25.6
200	14	75	5.17	598	16.1	1237	33.2	1715	46.0
		100	6.89	573	15.4	1180	31.7	1654	44.4
		125	8.62	531	14.2	1089	29.2	1540	41.4
		150	10.3	462	12.4	946	25.4	1350	36.2
		175	12.1	348	9.35	710	19.1	1022	27.4
225	16	75	5.17	674	18.1	1396	37.5	1929	51.8
		100	6.89	655	17.6	1352	36.3	1885	50.6
		125	8.62	623	16.7	1281	34.4	1802	48.4
		150	10.3	572	15.4	1173	31.5	1664	44.7
		175	12.1	495	13.3	1012	27.2	1447	38.8
		200	13.8	371	10.0	755	20.3	1088	29.2
250	17	75	5.17	749	20.1	1553	41.7	2139	57.4
		125	8.62	709	19.0	1460	39.2	2045	54.9
		150	10.3	669	18.0	1375	36.9	1941	52.1
		175	12.1	612	16.4	1253	33.6	1781	47.8
		200	13.8	526	14.1	1075	28.8	1538	41.3
		225	15.5	392	10.5	798	21.4	1149	30.9
285	20	75	5.17	851	22.9	1769	47.5	2427	65.2
		125	8.62	823	22.1	1699	45.6	2366	63.5
		150	10.3	794	21.3	1634	43.9	2293	61.5
		175	12.1	752	20.2	1544	41.4	2180	58.5
		200	13.8	693	18.6	1419	38.1	2017	54.1
		225	15.5	609	16.4	1245	33.4	1781	47.8

**Table 13. Type EZL Dimensions**

BODY SIZE		DIMENSION																			
		A						D		G		M		N		J		O		P	
		CL125 FF, CL150 RF		CL250 RF, CL300 RF		CL600 RF, BWE															
In.	DN	In.	mm	In.	mm	In.	mm	In.	mm	In.	mm	In.	mm	In.	mm	In.	mm	In.	mm		
2	50	10.00	254	10.50	267	11.25	286	12.50	318	3.06	78	16.25	413	8.66	220	13.53	344	10.50	267	12.50	318
3	80	11.75	298	12.50	318	13.25	337	15.49	393	3.81	97	17.58	447	9.99	254	16.52	420	11.83	300	14.13	359
4	100	13.90	353	14.50	368	15.50	394	16.67	423	5.10	130	17.58	447	9.99	254	19.03	483	11.83	300	14.13	359

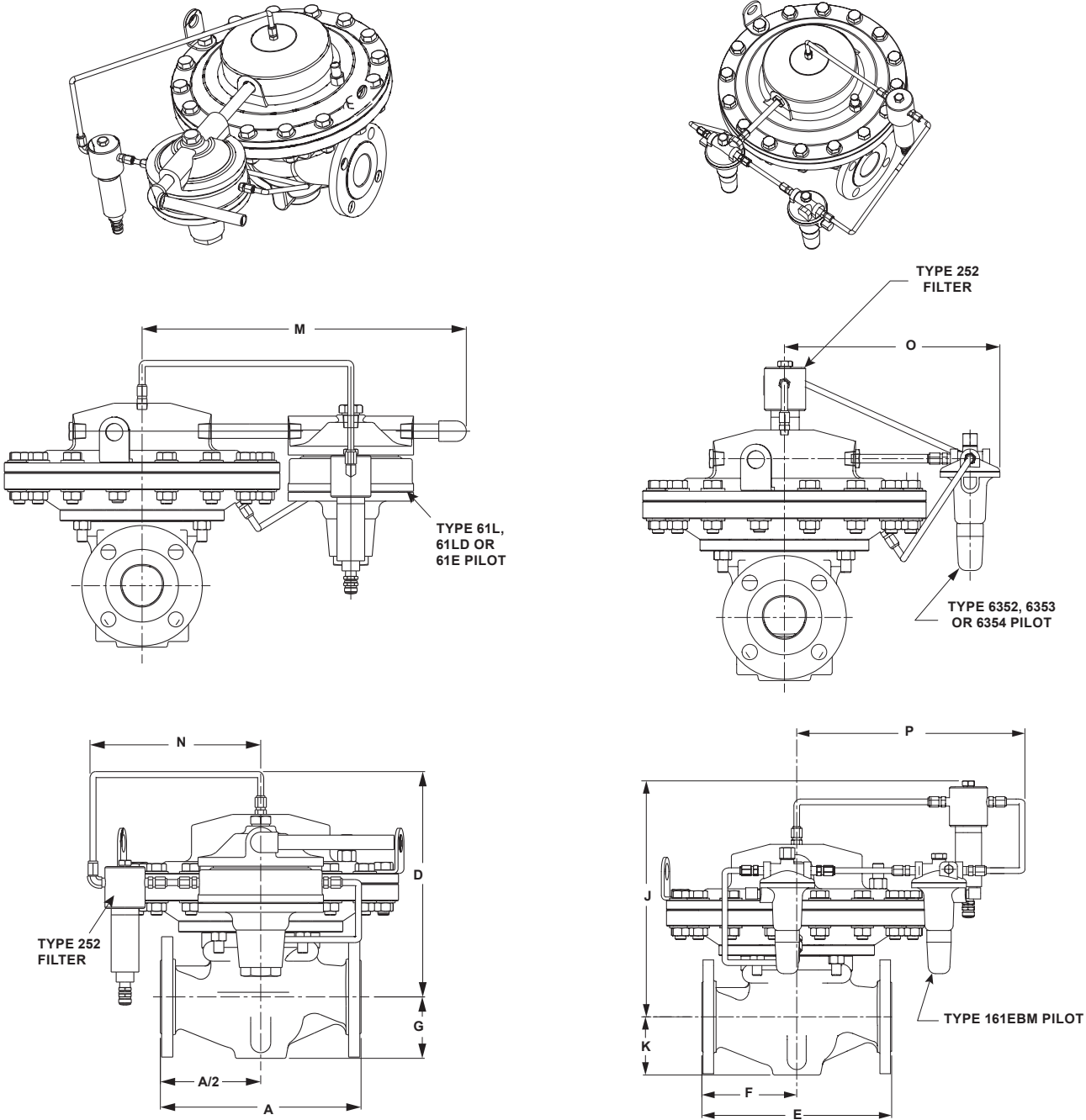

GE11539\_B

GE12413\_B

Figure 10. Type EZL Dimensions

# Type EZL

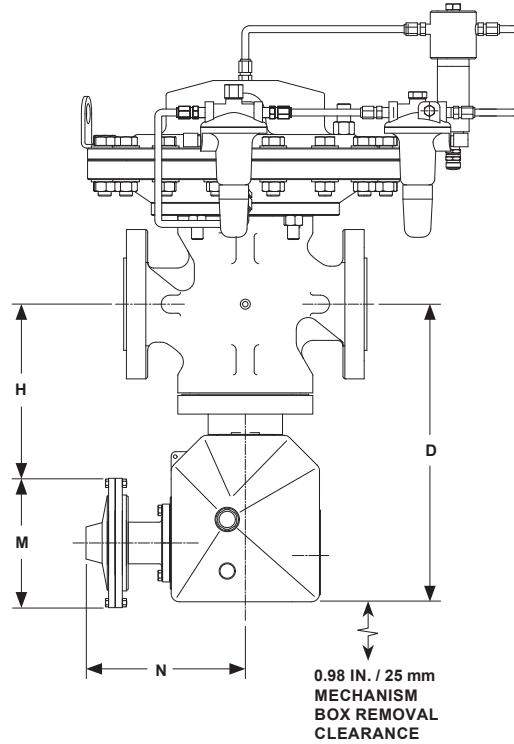

Figure 11. Type EZLOSX Dimensions

Table 14. Type EZLOSX Dimensions

BODY SIZE		DIMENSION WITH SLAM-SHUT													
		D		H		M <sup>(1)</sup>				N					
						Diaphragm		Piston		Diaphragm		Piston		Bellow	
In.	DN	In.	mm	In.	mm	In.	mm	In.	mm	In.	mm	In.	mm	In.	mm
2	50	13.0	330	10.4	264	6.38	162	2.80	71	6.89	175	8.03	204	8.78	223
3	80	14.34	364	11.78	299	6.38	162	2.80	71	6.89	175	8.03	204	8.78	223
4	100	15.64	397	13.09	332	6.38	162	2.80	71	6.89	175	8.03	204	8.78	223

1. Type 71 BMS with a diaphragm has an M dimension of 2.80 in. / 71 mm.

Table 15. Shipping Weights

BODY SIZE		APPROXIMATE SHIPPING WEIGHT													
		NPT		SWE		CL150 RF		CL300 RF		CL600 RF		SCH 40		Actuator Only	
In.	DN	Lbs	kg	Lbs	kg	Lbs	kg	Lbs	kg	Lbs	kg	Lbs	kg	Lbs	kg
2	50	90	41	90	41	97	44	107	49	111	50	90	41	45	20
3	80	----		----		172	78	182	83	186	84	----		80	36
4	100	----		----		201	91	225	102	270	122	----		85	39

## Ordering Guide

### Body Size (Select One)

- 2 in. / DN 50 Body\*\*\*
- 3 in. / DN 80 Body\*\*\*
- 4 in. / DN 100 Body\*\*\*

### Body Material and End Connection Style (Select One)

#### WCC Steel

- NPT (2 in. only)\*\*\*
- CL150 RF\*\*\*
- CL300 RF\*\*\*
- CL600 RF\*\*\*
- BWE (Schedule 40)\*\*
- SWE\*\*

#### Cast Iron

- NPT (2 in. only)\*\*\*
- CL125 FF\*\*\*

### Main Valve Seat Material (Select One)

- Nitrile (NBR) (standard)\*\*\*
- Fluorocarbon (FKM)\*\*\*

### Outlet Pressure Range (Select One)

#### Type 61L

- 0.25 to 2 psig / 0.017 to 0.14 bar, Red\*\*\*
- 1 to 5 psig / 0.069 to 0.35 bar, Yellow\*\*\*
- 2 to 10 psig / 0.14 to 0.69 bar, Blue\*\*\*
- 5 to 15 psig / 0.35 to 1.03 bar, Brown\*\*\*
- 10 to 20 psig / 0.69 to 1.38 bar, Green\*\*\*

#### Type 61HP

- 15 to 45 psig / 1.03 to 3.10 bar, Yellow\*\*\*
- 35 to 100 psig / 2.41 to 6.90 bar, Blue\*\*\*
- 100 to 300 psig / 6.90 to 20.7 bar, Red<sup>(1)</sup>\*\*\*

#### Type 6352

- 2 to 10 psig / 0.14 to 0.69 bar, Black\*\*\*

#### Type 6353

- 3 to 40 psig / 0.21 to 2.8 bar\*\*\*
- 35 to 125 psig / 2.41 to 8.6 bar, Red\*\*\*

#### Type 6354L, 6354M or 6354H

- 85 to 200 psig / 5.9 to 13.8 bar, Blue\*\*\*
- 175 to 220 psig / 12.1 to 15.2 bar, Blue\*\*\*
- 200 to 300 psig / 13.8 to 20.7 bar, Green<sup>(1)</sup>\*\*\*

#### Type 161EBM

- 5 to 15 psig / 0.35 to 1.03 bar, White\*\*\*
- 10 to 40 psig / 0.69 to 2.8 bar, Yellow\*\*\*
- 30 to 75 psig / 2.07 to 5.17 bar, Black\*\*\*
- 70 to 140 psig / 4.83 to 9.65 bar, Green\*\*\*
- 130 to 200 psig / 8.96 to 13.8 bar, Blue\*\*\*
- 200 to 350 psig / 13.8 to 24.1 bar, Red<sup>(1)</sup>\*\*\*

### Pilot Elastomer Material (Select One)

- Nitrile (NBR) (standard)\*\*\*
- Fluorocarbon (FKM)\*\*\*

### Travel Indicator (Optional)

- Yes\*\*\*
- No\*\*\*

### Main Valve Replacement Parts Kit (Optional)

- Yes, send one replacement parts kit to match this order.

### Pilot Replacement Parts Kit (Optional)

- Yes, send one replacement parts kit to match this order.

1. Operating range is limited to maximum pressure.

Regulators Quick Order Guide	
***	Readily Available for Shipment
**	Allow Additional Time for Shipment
*	Special Order, Constructed from Non-Stocked Parts. Consult your local Sales Office for Availability.
Availability of the product being ordered is determined by the component with the longest shipping time for the requested construction.	

### Specification Worksheet

#### Application:

Specific Use \_\_\_\_\_

Line Size \_\_\_\_\_

Fluid Type \_\_\_\_\_

Specific Gravity \_\_\_\_\_

Temperature (Ambient Range + Fluid Temp Range) \_\_\_\_\_

Does the Application Require Overpressure Protection? \_\_\_\_\_

- Yes  No

#### Pressure:

Maximum Inlet Pressure \_\_\_\_\_

Minimum Inlet Pressure \_\_\_\_\_

Differential Pressure \_\_\_\_\_

Set Pressure \_\_\_\_\_

Maximum Flow \_\_\_\_\_

#### Accuracy Requirements:

##### Less Than or Equal To:

- 5%  10%  20%  40%

#### Construction Material Requirements (if known):

\_\_\_\_\_

\_\_\_\_\_

✉ [Webadmin.Regulators@emerson.com](mailto:Webadmin.Regulators@emerson.com)

🔍 [Fisher.com](http://Fisher.com)

📘 [Facebook.com/EmersonAutomationSolutions](https://Facebook.com/EmersonAutomationSolutions)

🌐 [LinkedIn.com/company/emerson-automation-solutions](https://LinkedIn.com/company/emerson-automation-solutions)

🐦 [Twitter.com/emr\\_automation](https://Twitter.com/emr_automation)

## Emerson Automation Solutions

### Americas

McKinney, Texas 75070 USA  
T +1 800 558 5853  
+1 972 548 3574

### Europe

Bologna 40013, Italy  
T +39 051 419 0611

### Asia Pacific

Singapore 128461, Singapore  
T +65 6770 8337

### Middle East and Africa

Dubai, United Arab Emirates  
T +971 4 811 8100

D103092X012 © 2005, 2019 Emerson Process Management Regulator Technologies, Inc. All rights reserved. 12/19.

The Emerson logo is a trademark and service mark of Emerson Electric Co. All other marks are the property of their prospective owners. Fisher™ is a mark owned by Fisher Controls International LLC, a business of Emerson Automation Solutions.

The contents of this publication are presented for informational purposes only, and while every effort has been made to ensure their accuracy, they are not to be construed as warranties or guarantees, express or implied, regarding the products or services described herein or their use or applicability. All sales are governed by our terms and conditions, which are available upon request. We reserve the right to modify or improve the designs or specifications of such products at any time without notice.

Emerson Process Management Regulator Technologies, Inc does not assume responsibility for the selection, use or maintenance of any product. Responsibility for proper selection, use and maintenance of any Emerson Process Management Regulator Technologies, Inc. product remains solely with the purchaser.

