

## Proportional pressure relief cartridge with integrated electronics

- ◆ pilot operated
- ◆  $Q_{\max} = 100 \text{ l/min}$
- ◆  $p_{\max} = 400 \text{ bar}$
- ◆  $p_{N\max} = 350 \text{ bar}$

### DESCRIPTION

Pilot operated proportional pressure relief valve with integrated electronics as screw-in cartridge for cavity according to ISO 7789. When the operating pressure adjusted by means of the proportional solenoid is reached, the valve opens and connects the protected line with the drain to the tank. The back pressure in T (2) affects the pressure in P (1). This proportional valve is very sensitively adjustable and suitable for high pressures. The Plug & Play valves are factory set and adjusted and have therefore a high valve-to-valve reproducibility. The control takes place via an analogue interface or a fieldbus interface (CANopen, J1939 or Profibus DP). The parameterisation takes place by means of the free of cost parameterisation and diagnostics software «PASO» or via fieldbus interface. The USB parameterisation interface is accessible through a screw plug. As an option, these valves are available with integrated controller. As feedback value generators sensors with voltage or current output can be connected directly. The available controller structures are optimised for applications with hydraulic actuations.

### SYMBOL

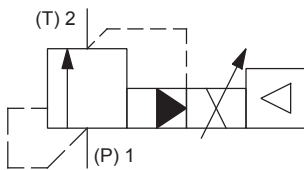

### ELECTRICAL SPECIFICATIONS

Protection class	IP67 with suitable mating connector and closed housing cover
Ramps	Adjustable
Parameterisation	Via fieldbus or USB
Supply voltage	12 VDC, 24 VDC

**Note!** Exact electrical specifications and detailed description of «DSV» electronics can be found on data sheet 1.13-76.



M22 x 1,5  
ISO 7789

**DSV**  
DIGITAL  
ALVE  
MART

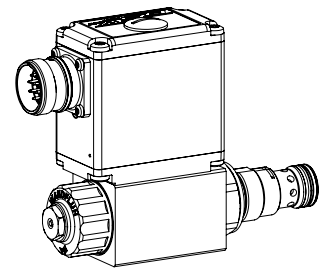

### APPLICATION

Proportional pressure relief valves with integrated electronics are perfectly suitable for demanding applications in which the pressure frequently has to be changed. They are used in applications where high valve-to-valve reproducibility, easy installation, comfortable operation and high precision are very important. The integrated controller relieves the machine control and operates the pressure control in a closed loop circuit. The applications are in the industrial as well as in the mobile hydraulics for the smooth control of hydraulic actuations. The screw-in cartridge is perfectly suitable for installation in control blocks and is installed in sandwich- (vertical stacked systems) and in flange plates (corresponding data sheets in this register). For machining the cartridge cavity in steel and aluminum blocks, cavity tools are available (hire or purchase). Please refer to the data sheets in register 2.13.

**Note!**



„PASO“ is a Windows programm in the flow diagram style, which enables the intuitive adjustment and storing of all variable parameters. The data remain saved in case of a power failure and can also be reproduced and transferred to other DSV.

### ACTUATION

Actuation	Proportional solenoid, wet pin push type, pressure tight
Connection	Via device receptacle

### MANUAL OVERRIDE

HB4,5 as standard

**TYPE CODE**

		B		V	P	PM22	-	<input type="text"/>	-	<input type="text"/>	/	M	E	<input type="text"/>	<input type="text"/>	-	<input type="text"/>	HB4,5	#	<input type="text"/>
Pressure relief valve																				
Pilot operated																				
Proportional																				
Screw-in cartridge M22 x 1,5																				
Nominal pressure range $p_N$	20 bar	<input type="text" value="20"/>	200 bar	<input type="text" value="200"/>																
	63 bar	<input type="text" value="63"/>	275 bar	<input type="text" value="275"/>																
	100 bar	<input type="text" value="100"/>	350 bar	<input type="text" value="350"/>																
	160 bar	<input type="text" value="160"/>																		
Nominal voltage $U_N$	12 VDC	<input type="text" value="G12"/>																		
	24 VDC	<input type="text" value="G24"/>																		
Slip-on coil	Metal housing square																			
Connection execution	Integrated electronics																			
Hardware configuration																				
Analog command value signal	12 pole	<input type="text" value="A1"/>	7 pole	<input type="text" value="D1"/>	(0 ... 10 V preset)															
Analog command value signal	12 pole	<input type="text" value="A4"/>	7 pole	<input type="text" value="D4"/>	(4 ... 20 mA preset)															
CANopen according to DSP-408	<input type="text" value="C1"/>																			
Profibus DP according to Fluid Power Technology	<input type="text" value="P1"/>																			
CAN J1939 (on request)	<input type="text" value="J1"/>																			
Function																				
Amplifier	<input type="text"/>																			
Controller with current feedback value signal (0...20 mA / 4...20 mA)	<input type="text" value="R1"/>																			
Controller with voltage feedback value signal (0...10 V)	<input type="text" value="R2"/>																			
Sealing material	NBR	<input type="text"/>																		
	FKM (Viton)	<input type="text" value="D1"/>																		
Manual override																				
Design index (subject to change)																				

2.3-537

**GENERAL SPECIFICATIONS**

Designation	Proportional pressure relief valve with integrated electronic
Construction	Pilot operated
Mounting	Screw-in cartridge construction
Nominal size	M22 x 1,5 according to ISO 7789
Actuation	Proportional solenoid
Ambient temperature	-20...+65 °C The upper temperature limit is a guideline for typical applications, in individual cases it may also be higher or lower. The electronics of the valve limit the power in case of a too high electronics temperature. More detailed information can be obtained from the operating instructions „DSV“.
Weight	1,0 kg
MTTFd	150 years

**HYDRAULIC SPECIFICATIONS**

Working pressure	$p_{max} = 400$ bar
Tank pressure	$p_{Tmax} = p_p + 20$ bar
Nominal pressure range	$P_N = 20$ bar, 63 bar, 100 bar, 160 bar, 200 bar, 275 bar, 350 bar
Volume flow range	$Q = 0,3...100$ l/min
Leakage oil	See characteristics
Hysteresis	≤ 4 % at optimal dither signal
Repeatability	≤ 2 % at optimal dither signal
Fluid	Mineral oil, other fluid on request
Viscosity range	12 mm <sup>2</sup> /s...320 mm <sup>2</sup> /s
Temperature range fluid	-25...+70 °C (NBR) -20...+70 °C (FKM)
Contamination efficiency	Class 18 / 16 / 13
Filtration	Required filtration grade $\beta_{6...10} \geq 75$ , see data sheet 1.0-50

**ELECTRICAL CONNECTION**

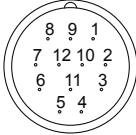
X1	Analog interface (Main)
Device receptacle	M23, 12 pole male
	1 = Supply voltage + 2 = Supply voltage 0 VDC 3 = Stabilised output voltage 4 = Command value signal voltage + 5 = Command value signal voltage - 6 = Command value signal current + 7 = Command value signal current - 8 = Reserved for extentions 9 = Reserved for extentions 10 = Enable signal (Digital input) 11 = Error signal (Digital output) 12 = Chassis
Command value signal voltage (PIN 4/5) resp. current (PIN 6/7) are selected with parameterisation and diagnostics software PASO.	

X1	Fieldbus interface (Main)
Device receptacle	M12, 4 pole male
	1 = Supply voltage + 2 = Reserved for extentions 3 = Supply voltage 0 VDC 4 = Chassis

X2	Parameterisation interface
USB, Mini B	Under the screw plug of the housing cover Factory set

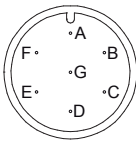
X1	Analog interface (Main)
Device receptacle	Connector DIN EN 175201 - 804
	7 pole male A = Supply voltage + B = Supply voltage 0 VDC C = Not connected D = Command value signal + E = Command value signal - F = Not connected G = Chassis
Command value signal: current (D4) or voltage (D2) to specify when placing the order	

X3	Profibus interface according to IEC 947-5-2
Device receptacle	M12, 5 pole female B-coded
	1 = VP 2 = Rx/D / Tx/D - N 3 = DGND 4 = Rx/D / Tx/D - P 5 = Shield

X3	CANopen interface according to DRP 303-1
Device receptacle	M12, 5 pole male
	1 = Not connected 2 = Not connected 3 = CAN Gnd 4 = CAN High 5 = CAN Low

X4 (controller only)	Feedback value interface (sensor)
Device receptacle	M12, 5 pole female
	1 = Supply voltage (output) + 2 = Feedback value signal + 3 = Supply voltage 0 VDC 4 = Not connected 5 = Stabilised output voltage
Feedback value signal: current (R1) or voltage (R2) to specify when placing the order	

**Note!** The mating connector is not included in the delivery

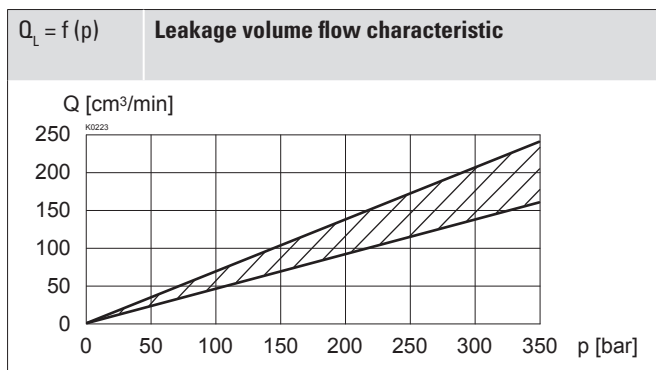
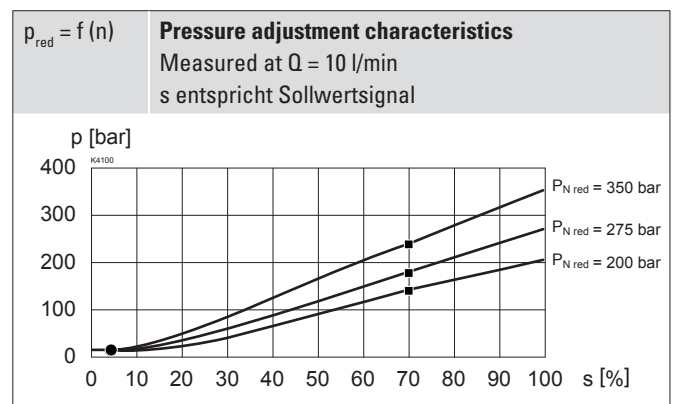
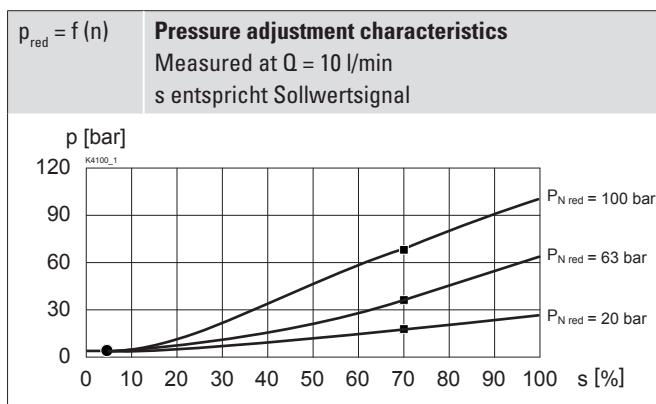
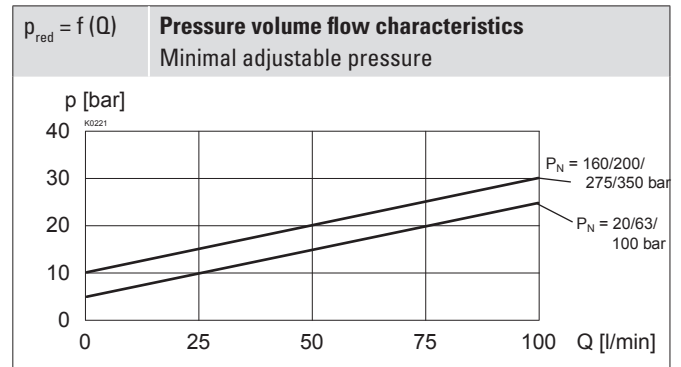
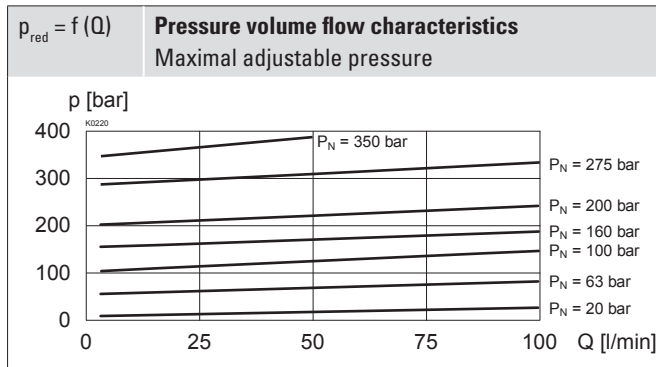

**PERFORMANCE SPECIFICATIONS**

 Oil viscosity  $\nu = 30 \text{ mm}^2/\text{s}$ 

**FACTORY SETTINGS**

Dither set for optimum hysteresis

● = Deadband: solenoid switched off at command value signal &lt; 5 %

■ = Limited pressure in port P (1) at 70 % command value signal

248 bar	at nominal pressure range $p_N$	350 bar
192 bar	at nominal pressure range $p_N$	275 bar
144 bar	at nominal pressure range $p_N$	200 bar
114 bar	at nominal pressure range $p_N$	160 bar
72 bar	at nominal pressure range $p_N$	100 bar
46 bar	at nominal pressure range $p_N$	63 bar
16 bar	at nominal pressure range $p_N$	20 bar

**DIMENSIONS**
**With analog interface, 12 pole connector**

Amplifier and controller

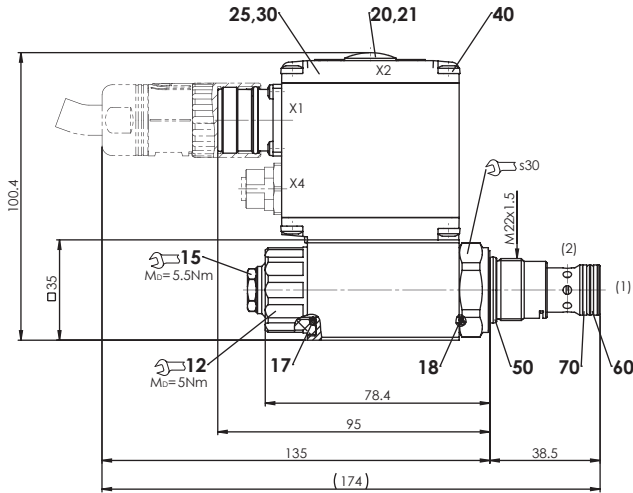

X4 (controller only)

**With fieldbus interface**

Amplifier

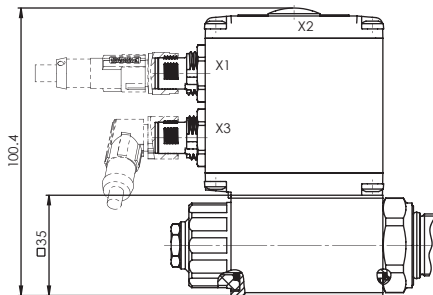
**With analog interface, 7 pole connector**

Amplifier and controller

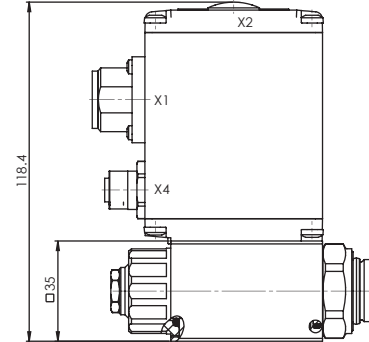
**With fieldbus interface**

Controller

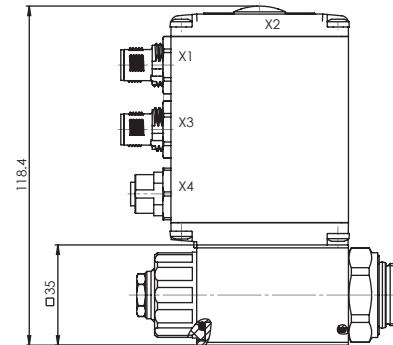
**HYDRAULIC CONNECTION**

Cavity drawing according to ISO 7789-22-02-0-98

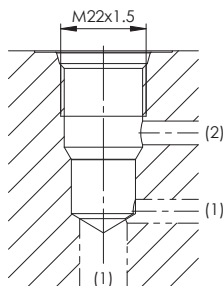
**Note!**

For detailed cavity drawing and cavity tools see data sheet 2.13-1003

**PARTS LIST**

Position	Article	Description
12	154.2700	Knurled nut
15	253.8000	Manual override HB4,5
17	160.2187	O-ring ID 18,72 x 2,62 (NBR)
18	160.2170	O-ring ID 17,17 x 1,78 (NBR)
20	223.1317	Dummy plug M16 x 1,5
21	160.6131	O-ring ID 13,00 x 1,5 (FKM)
25	062.0102	Cover
30	072.0021	Gasket 33,2 x 59,9 x 2
40	208.0100	Socket head screw M4 x 10
50	160.2188	O-ring ID 18,77 x 1,78 (NBR)
	160.6188	O-ring ID 18,77 x 1,78 (FKM)
60	160.2140	O-ring ID 14,00 x 1,78 (NBR)
	160.6141	O-ring ID 14,00 x 1,78 (FKM)
70	049.3177	Back-up ring rd 14,6 x 17,5 x 1,4

## ACCESSORIES

Parameterisation software	See start-up
Parameterisation cable for interface USB (from plug type A on Mini B, 3 m)	Article no. 219.2869
Mating connector (plug female) for analog interface	
straight, soldering contact M23, 12 pole	Article no. 219.2330
angled, soldering contact M23, 12 pole	Article no. 219.2331
straight, soldering contact, 7 pole	Article no. 219.2335
Flange body / sandwich plate NG4-Mini	Data sheet 2.3-720
Flange body / sandwich plate NG6	Data sheet 2.3-740
Flange body / sandwich plate NG10	Data sheet 2.3-760
Threaded body	Data sheet 2.9-200
Technical explanations	Data sheet 1.0-100
Filtration	Data sheet 1.0-50

**Attention!** Auxiliary conditions for the cable:

- External diameter 12 pol: 3,5...14,7 mm
- External diameter 7 pol: 8...10 mm
- Wire cross section max. 1 mm<sup>2</sup>
- Recommended wire cross section:  
 0...25 m = 0,75 mm<sup>2</sup> (AWG18)  
 25...50 m = 1 mm<sup>2</sup> (AWG17)



## SURFACE TREATMENT

- ◆ The cartridge body and the solenoid are zinc-nickel coated
- ◆ The electronics housing is made of aluminium.

## STANDARDS

Cartridge cavity	ISO 7789
CANopen	DRP 303-1
Profibus DP	IEC 947-5-2
Protection class	EN 60 529
Contamination efficiency	ISO 4406

## COMMISSIONING

For DSV amplifiers as a rule no parameter adjustments by the customer are required. The plugs have to be connected in accordance with the chapter «Electrical connection».

Controllers are supplied configured as amplifiers. The adjustment of the mode of control and of the controller are carried out by the customer by means of the software adjustment (USB interface, Mini B). Further information can be found on: «www.wandfluh.com». Free- of charge download of the «PASO» software and the operation instructions for «DSV» hydraulic valves as well as the operation instructions CANopen Protocol resp. Profibus DP Protocol, with Device Profile DSP-408 for «DSV».

### Note!



The mating connectors and the parameterisation cable are not part of the delivery. Refer to chapter «Accessories».

## SEALING MATERIAL

NBR or FKM (Viton) as standard, choice in the type code

## INSTALLATION NOTES

Mounting type	Screw-in cartridge M22 x 1,5
Mounting position	Any, preferably horizontal
Tightening torque	M <sub>0</sub> = 60 Nm Screw-in cartridge M <sub>0</sub> = 5 Nm knurled nut