



SWI - Critical Service Valves for the World's Industries

www.swivalve.com





CRITICAL SERVICE VALVES FOR THE WORLD'S INDUSTRIES

At a Glance

SWI Valve Co Ltd (SWI) is a leading manufacturer of industrial valves with over 28 years of experience in manufacturing and international selling. A widely approved brand with global majors, SWI has established a substantial presence in the oil and gas industry especially through the supply of our products in high-profile, off-shore upstream projects. SWI's product range includes gate, globe, check, ball, cryogenic, bellows sealed, double block & bleed and instrumentation valves for critical applications in the chemical, petrochemical, oil & gas and allied industries. With our breadth of experience and expertise in the valve industry, we offer innovative solutions and precise execution to meet the most demanding requirements of engineering companies and end users around the globe.

Manufacturing Plants

- Head-office & Plant 1 located in Anyang, South Korea
- Plant 2 located in Pyeongtaek, South Korea

Sales Offices

- Sales Office & Warehouse in Houston, TX, USA
- Sales Office in Los Angeles, CA, USA

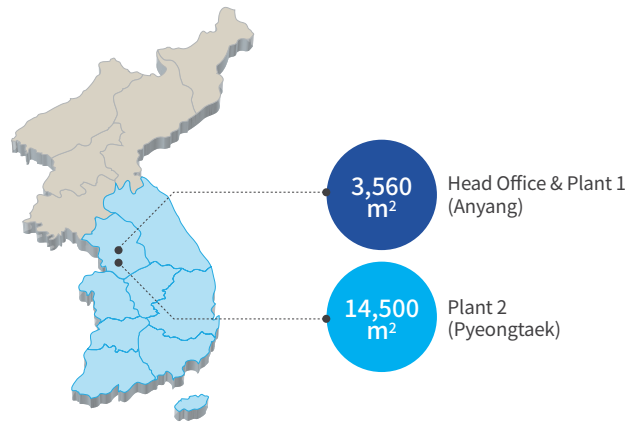

Timeline

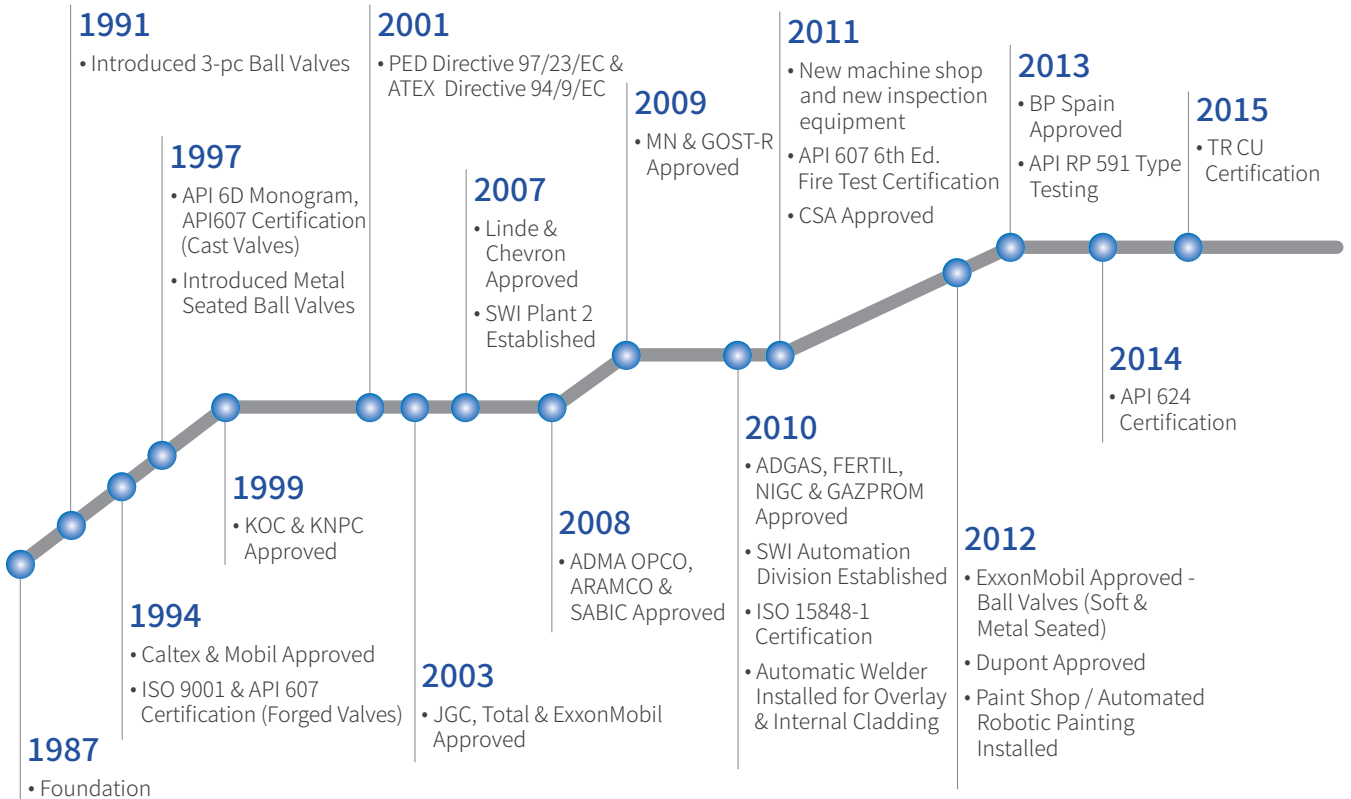

A Wide Range of Industrial Valves of Exceptional Quality

SWI is renowned for producing high quality products. All of our products are designed, machined, assembled and tested using strict quality control to ensure outstanding product quality. Furthermore, where we have truly taken an industry leadership role is in specialty and exotic valve products. We design, manufacture and market the broadest range of ASME, cryogenic and bellows sealed valves in the industry.

Products

Forged Steel Valves & High Alloy Cast Steel Valves



Ball Valves - Floating, Trunnion Mounted & Top Entry



Bellows Seal Valves



Automation



Triple Offset Butterfly Valves



Positive Isolation Block & Bleed Valves



Cryogenic Service Valves



Instrumentation Valves

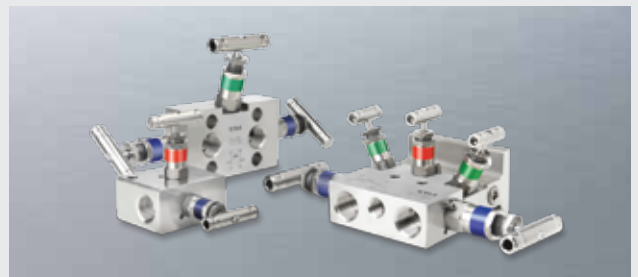



FORGED STEEL GATE/GLOBE/CHECK VALVES

1/2" - 2" VALVES	SW - NPT - BW						FLANGED				
	800#	1500#	1690#	2500#	2680#	4500#	150#	300#	600#	1500#	2500#
GATE											
GATE - Bellows Seal											
GLOBE											
GLOBE - Bonnetless											
GLOBE - Bellows Seal											
GLOBE - Stop Check											
GLOBE - Needle											
Y - GLOBE											
Y - GLOBE - Bellows Seal											
Y - GLOBE - Stop Check											
Y - GLOBE - Needle											
ANGLE GLOBE											
ANGLE GLOBE - Stop Check											
CHECK - Piston											
CHECK - Swing											
CHECK - Ball											
Y CHECK - Piston											
Y CHECK - Ball											





Valve Types

- Gate Standard, Bellows Seal & Cryogenic
- Globe Standard, Needle, Stop Check, Y Pattern, Bellows Seal, Cryogenic & Bonnet-less in-line maintainable
- Check Piston, Swing, Ball & Y Pattern

General Design & Wall Thickness

- Full & Reduced Port : Class 150#, 300#, 600#, 800# & 1500#
Gate (API 602 / ASME B16.34 / ISO 15761), Globe & Check (API 602 / ASME B16.34 / BS5352 / ISO 15761)
- Full Port : Class 1500#, 1690#, 2500#, 2680#, 4500#, Gate / Globe / Check (ASME B16.34)

Available Bonnet Configurations

- Bolted • Screwed & Seal Welded • Fully Welded • Pressure Seal • Bonnetless

Certifications

- ISO 15848-1 & API 624 Fugitive Emission
- API 607 6th Edition / ISO 10497
- Directive 97/23/EC (PED) and ATEX 94/9/EC

End to End Dimensions

- Flanged ASME B16.10
- Butt Weld Maker's standard
- Screwed & Socket Weld Maker's standard

API Trims

Trim No. 5, 8, 12 & 16, other API trims available on request.

NACE

NACE MR0175 / ISO 15156 or MR0103 compliance available.

End Connections

- Flanged ASME B16.5
- Butt Weld ASME B16.25
- Screwed ASME B1.20.1
- Socket Weld ASME B16.11

BELLOWS SEAL GATE/GLOBE VALVES

CONNECTION		SW-NPT-BW-FLANGED					FLANGED-BW												
TYPE & RATING		½"	¾"	1"	1½"	2"	2"	3"	4"	6"	8"	10"	12"	14"	16"	18"	20"	24"	36"
GATE	150#	■	■	■	■	■	■	■	■	■	■	■	■	■	■	■	■	■	■
	300#	■	■	■	■	■	■	■	■	■	■	■	■	■	■	■	■	■	■
	600#	■	■	■	■	■	■	■	■	■	■	■	■	■	■	■	■	■	■
	800#	■	■	■	■	■	■	■	■	■	■	■	■	■	■	■	■	■	■
	900#	■	■	■	■	■	■	■	■	■	■	■	■	■	■	■	■	■	■
	1500#	■	■	■	■	■	■	■	■	■	■	■	■	■	■	■	■	■	■
GLOBE	150#	■	■	■	■	■	■	■	■	■	■	■	■	■	■	■	■	■	■
	300#	■	■	■	■	■	■	■	■	■	■	■	■	■	■	■	■	■	■
	600#	■	■	■	■	■	■	■	■	■	■	■	■	■	■	■	■	■	■
	800#	■	■	■	■	■	■	■	■	■	■	■	■	■	■	■	■	■	■
	900#	■	■	■	■	■	■	■	■	■	■	■	■	■	■	■	■	■	■
	1500#	■	■	■	■	■	■	■	■	■	■	■	■	■	■	■	■	■	■

Helium Leak Test : Performed for each bellows assembly using helium detector with sensitivity of 10^{-7} cc/sec.

Bellows Material : SS321, Inconel 625, Hastelloy, Monel etc.

Fully Welded or Modular Design : Two or three section assembly.

Hydroformed Multiply Bellows : Minimum of two plies.

Soft Seat Insert on Globe Valves : Soft seat option is available for gas or vacuum service.

Impact Handwheel : Globe Valves fitted with impact handwheels which may be used to give effectively 3~10 times higher closing force.





General Design & Wall Thickness

- Forged Gate Valves - API 602 / ASME B16.34 / ISO 15761
- Forged Globe Valves - API 602 / ASME B16.34 / BS5352 / ISO 15761
- Cast Gate Valves - ASME B16.34 / ISO 10434
- Cast Globe Valves - ASME B16.34 / BS1873

Bellows Inspection & Test : MSS SP-117 / API 602

Cycle Life

Size (Inch)	Classes 150# - 800#		Classes 900# & 1500#	
	Gate Valves	Globe Valves	Gate Valves	Globe Valves
≤2"	2000	5000	2000	2000
2½" ~ 4"	2000	5000	1000	2000
5" ≤	1000	2000	1000	1000

Cycle Life Test : Performed under the maximum pressure condition.

Non-Rotating stem : Prevents torsion of bellows.

Two Secondary Stem Seals

Stem backseat and stem packing ensure perfect sealing in the event of bellows damage.

Long Life Seating Surface : Stellite 6 faced both seat and wedge / disc to prevent seizing and galling is available.

End Flange Dimensions : ASME B16.5

Butt Weld End Dimensions : ASME B16.25

End to End Dimensions

- Flanged - ASME B16.10
- Butt Weld - Cast Valves: ASME B16.10
- Forged Valves: Maker's standard
- Screwed & Socket Weld - Maker's standard.

NACE : NACE MR0175 / ISO 15156 or MR0103 compliance available.



HIGH INTEGRITY BALL VALVES

CONNECTION		SW-NPT-BW-FLANGED						FLANGED-BW															
TYPE & RATING		1/2"	3/4"	1"	1 1/2"	2"	3"	4"	6"	8"	10"	12"	14"	16"	18"	20"	24"	26"	28"	30"	36"	40"	48"
BALL Floating End Entry	150#																						
	300#																						
	600#																						
	800#																						
	900#																						
	1500#																						
	2500#																						
BALL Trunnion End Entry	150#																						
	300#																						
	600#																						
	900#																						
	1500#																						
	2500#																						
	BALL Trunnion Top Entry	150#																					
300#																							
600#																							
900#																							
1500#																							
2500#																							





General Design & Wall Thickness

- Floating Ball Valves - ISO 17292 / ASME B16.34 / API 608 / API 6D
- Trunnion Mounted Ball Valves - ISO 14313 / ASME B16.34 / API 6D
- Top Entry Ball Valves - ISO 14313 / ASME B16.34 / API 6D

Inspection & Test : API 598 / API 6D / EN 12266-1 / ISO 5208

End Flange Dimensions : ASME B16.5

Butt Weld End Dimensions : ASME B16.25

End to End Dimensions

- Flanged - ASME B16.10
- Butt Weld - ASME B16.10
- Screwed & Socket Weld - Maker's standard

Key Features

- Design, manufacture and materials conform to the essential requirements of API 6D, ISO 14313, ASME B16.34, ASME VIII and Directives PED 97/23/EC and ATEX 94/9/EC.
- NACE MR0175 / ISO 15156 or MR0103 compliance available.
- Certified firesafe in accordance with API 607 6th Edition / ISO 10497.
- Anti-static design (10Ω under 12 Volt).
- Fully contained body gasket, graphite seal is protected from the working fluid by primary elastomeric seal for soft seated.
- Internally assembled blow-out proof stem design. Bottom entry stem shouldered directly to the body and not to any other intermediate part bolted to the valve.
- Standard valve features high integrity stem sealing system in compliance with ISO 15848 Class AH suitable for high vacuum service and technically emission free.
- Trunnion Mounted & Top Entry valves feature in line maintainable stem sealing system. Replaceable without the need for valve disassembly or removal from the pipeline.
- Metal seated designs for critical or severe service.
- Low temperature and cryogenic service designs available.
- Available with pneumatic, hydraulic or electric actuators.

TRIPLE OFFSET BUTTERFLY VALVES

VALVE TYPE	ANSI CLASS	SIZE (NPS)																	
		3"	4"	6"	8"	10"	12"	14"	16"	18"	20"	24"	26"	28"	30"	36"	40"	42"	48"
Double Flanged Short	150#	Available	Available	Available	Available	Available	Available	Available	Available	Available	Available	Available	Available	Available	Available	Available	Available	Available	Available
	300#	Available	Available	Available	Available	Available	Available	Available	Available	Available	Available	Available	Available	Available	Available	Available	Available	Available	Available
	600#	Available	Available	Available	Available	Available	Available	Available	Available	Available	Available	Available	Available	Available	Available	Available	Available	Available	Available
	900#	Available	Available	Available	Available	Available	Available	Available	Available	Available	Available	Available	Available	Available	Available	Available	Available	Available	Available
Double Flanged Long	150#	Available	Available	Available	Available	Available	Available	Available	Available	Available	Available	Available	Available	Available	Available	Available	Available	Available	Available
	300#	Available	Available	Available	Available	Available	Available	Available	Available	Available	Available	Available	Available	Available	Available	Available	Available	Available	Available
	600#	Available	Available	Available	Available	Available	Available	Available	Available	Available	Available	Available	Available	Available	Available	Available	Available	Available	Available
	900#	Available	Available	Available	Available	Available	Available	Available	Available	Available	Available	Available	Available	Available	Available	Available	Available	Available	Available
Lug / Wafer	150#	Available	Available	Available	Available	Available	Available	Available	Available	Available	Available	Available	Available	Available	Available	Available	Available	Available	Available
	300#	Available	Available	Available	Available	Available	Available	Available	Available	Available	Available	Available	Available	Available	Available	Available	Available	Available	Available
	600#	Available	Available	Available	Available	Available	Available	Available	Available	Available	Available	Available	Available	Available	Available	Available	Available	Available	Available
	900#	Available	Available	Available	Available	Available	Available	Available	Available	Available	Available	Available	Available	Available	Available	Available	Available	Available	Available
Butt Weld	150#	Available	Available	Available	Available	Available	Available	Available	Available	Available	Available	Available	Available	Available	Available	Available	Available	Available	Available
	300#	Available	Available	Available	Available	Available	Available	Available	Available	Available	Available	Available	Available	Available	Available	Available	Available	Available	Available



The Triple-Offset Geometry

The SWI Triple-offset valve provides a bidirectional bubble tight shut-off to API 598. This geometry ensures that the disc seal contacts the body seat only at the final shut-off position without rubbing or galling, providing a torque generated resilient seal with sufficient wedging to ensure a uniform seal contact.

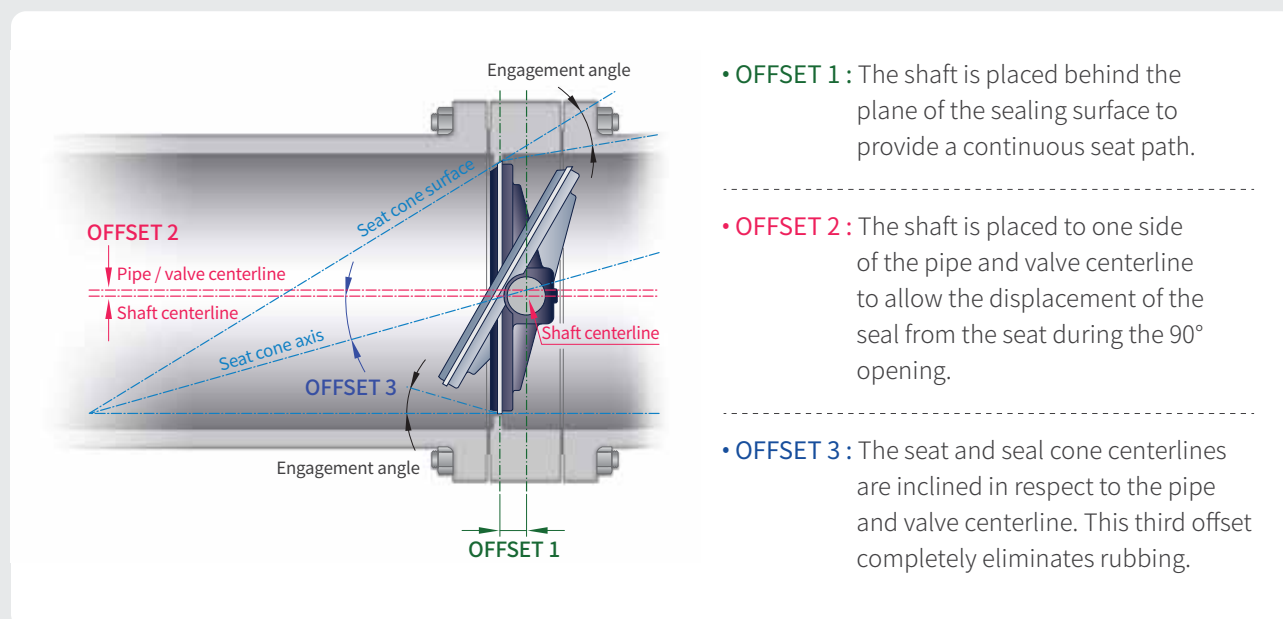

Key Features

- A Duplex metal seal ring and a highly wear-resistant Stellite 21 seat ensure superior tightness for a prolonged period
- Asymmetric design and disparate torque demands ensure bi-directional tightness
- Integral position indicators on the shaft and the top mounting flange provide positive indication of disc position
- All-metal construction produces an inherently fire safe valve
- Extensively hardened bearings, incorporating a standard reinforced, braided, flexible graphite bearing protector, ensure increased reliability
- Blowout-proof shaft is safe to operate and provides complete compliance with API 609 due to its four different internal and external retaining devices
- Cryogenic and high temperature service designs are available

Design Specifications

- Valve design, Pressure & Temperature ratings : ASME B16.34 / ASME VIII / API 609
- Face to face dimensions : API 609 / ASME B16.10 / ISO 5752
- Actuator mounting : ISO 5211
- Flange drilling : ASME B16.5 / ASME B16.47 / ISO 7005
- Seat testing : API 598 / API 6D / ISO 5208 / DIN 3230 / BS 6755
- Fire tested : API 607, 6th Edition / ISO 10497
- Fugitive emission testing : TA LUFT / ISO 15848
- Cryogenic service : BS 6364
- Valve markings : MSS-SP-25 / ASME B16.34



CRYOGENIC SERVICE GATE/GLOBE/CHECK/BUTTERFLY VALVES

CONNECTION		SW-NPT-BW-FLANGED					FLANGED-BW											
TYPE & RATING		½"	¾"	1"	1½"	2"	3"	4"	6"	8"	10"	12"	14"	16"	18"	20"	24"	36"
GATE	150#																	
	300#																	
	600#																	
	800#																	
	900#																	
	1500#																	
GLOBE	150#																	
	300#																	
	600#																	
	800#																	
	900#																	
	1500#																	
LIFT CHECK	150#																	
	300#																	
	600#																	
	800#																	
	900#																	
	1500#																	
BALL	150#																	
	300#																	
	600#																	
	800#																	
	900#																	
	1500#																	

VALVE TYPE	ANSI CLASS	SIZE (NPS) - DOUBLE FLANGED / LUG / WAFER / BUTT WELD																	
		3"	4"	6"	8"	10"	12"	14"	16"	18"	20"	24"	26"	28"	30"	36"	40"	42"	48"
TRIPLE OFFSET BUTTERFLY VALVE	150#																		
	300#																		
	600#																		
	900#																		





General Design & Wall Thickness

- Forged Gate Valves - API 602 / ASME B16.34 / ISO 15761
- Forged Globe Valves - API 602 / ASME B16.34 / BS5352 / ISO 15761
- Forged Check Valves - API 602 / ASME B16.34 / BS5352 / ISO 15761
- Cast Gate Valves - ASME B16.34
- Cast Globe Valves - ASME B16.34
- Floating Ball Valves - ISO 17292 / ASME B16.34 / API 608 / API 6D
- Trunnion Ball Valves - ISO 14313 / ASME B16.34 / API 6D
- Top Entry Ball Valves - ISO 14313 / ASME B16.34 / API 6D
- Triple Offset Butterfly Valves - API 609 / ASME B16.34 / ASME VIII

Inspection & Test : BS 6364, ISO 28921-1 or per client requirements

Long Life Seating Surface

Gate / Globe / Check Valves, Stellite 6 faced both seat and wedge / disc to prevent seizing and galling.

End Flange Dimensions : ASME B16.5 / ASME B16.47

Butt Weld End Dimensions : ASME B16.25

End to End Dimensions

- Flanged - ASME B16.10
- Butt Weld - Cast Valves: ASME B16.10
- Forged Valves: Maker's standard
- Screwed & Socket Weld - Maker's standard

Extended Bonnet : Bolted or integral vapour space extended bonnet in accordance with ISO 28921-1 to keep stem packing out of the cold zone and free of ice formation.

Austenitic Stainless Steel Forgings or Castings

Tough at cryogenic temperatures and can be classed as a 'cryogenic steel' with good impact strength and corrosion resistance.

Shell and Trim Parts : All austenitic stainless steel and sub-zero treated in LN².

Insulation Collar / Drip Plate : A "welded" insulation collar/drip plate or a "clamped on" insulation collar/drip plate can be provided on request.

NACE : NACE MR0175 / ISO 15156 or MR0103 compliance available.



POSITIVE ISOLATION BLOCK & BLEED VALVES

Type	ANSI Class	Size (NPS)									
		1/2"	3/4"	1"	1 1/2"	2"	3"	4"	5"	6"	
Modular	150#	Available	Available	Available	Available	Available	Available	Available	Available	Available	Available
	300#	Available	Available	Available	Available	Available	Available	Available	Available	Available	Available
	600#	Available	Available	Available	Available	Available	Available	Available	Available	Available	Available
	900#	Available	Available	Available	Available	Available	Available	Available	Available	Available	Available
	1500#	Available	Available	Available	Available	Available	Available	Available	Available	Available	Available
	2500#	Available	Available	Available	Available	Available	Available	Available	Available	Available	Available
Mono-flange	150#	Available	Available	Available	Available	Available	Not Available	Not Available	Not Available	Not Available	Not Available
	300#	Available	Available	Available	Available	Available	Not Available	Not Available	Not Available	Not Available	Not Available
	600#	Available	Available	Available	Available	Available	Not Available	Not Available	Not Available	Not Available	Not Available
	900#	Available	Available	Available	Available	Available	Not Available	Not Available	Not Available	Not Available	Not Available
	1500#	Available	Available	Available	Available	Available	Not Available	Not Available	Not Available	Not Available	Not Available
	2500#	Available	Available	Available	Available	Available	Not Available	Not Available	Not Available	Not Available	Not Available
Root	150#	Available	Available	Available	Not Available	Not Available	Not Available	Not Available	Not Available	Not Available	Not Available
	300#	Available	Available	Available	Not Available	Not Available	Not Available	Not Available	Not Available	Not Available	Not Available
	600#	Available	Available	Available	Not Available	Not Available	Not Available	Not Available	Not Available	Not Available	Not Available
	900#	Available	Available	Available	Not Available	Not Available	Not Available	Not Available	Not Available	Not Available	Not Available
	1500#	Available	Available	Available	Not Available	Not Available	Not Available	Not Available	Not Available	Not Available	Not Available
	2500#	Available	Available	Available	Not Available	Not Available	Not Available	Not Available	Not Available	Not Available	Not Available

Valve Range

SWI Positive Isolation Block & Bleed Valves are designed to replace conventional multiple valve installations used for gauge, isolation, instrument, drain and take off point applications.

The product range features an integrally forged single piece double block & bleed valve assembly providing a compact design that offers high savings on cost, space and weight over the traditional hook up installation methods of such instruments.

These compact valve assemblies are widely used in the offshore oil and gas, chemical and petrochemical, filter manufacturing, refining, fiscal metering skids and power industry due to the obvious benefits that the SWI products deliver.

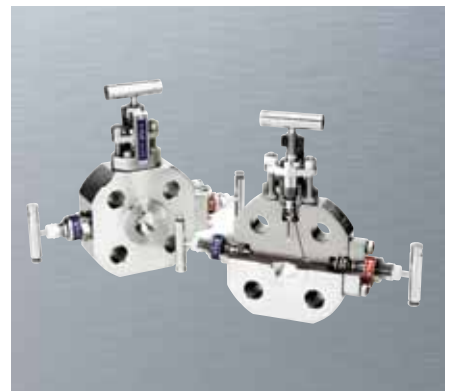



General Design & Wall Thickness

- ASME B16.34 - Design & Wall Thickness
- ASME Sec. VIII - Design Procedures and Material
- Directive 97/23/EC - PED & CE marking
- Directive 94/9/EC - ATEX

End Connections

- Flanged - ASME B16.5
- Screwed - ASME B1.20.1

Inspection & Test

- API 598 including optional hydrostatic seat tests.
- Testing in accordance with API 6D, EN12266-1 or ISO 5208 can be provided on request.

Key Features

- Design, manufacture and materials conform to the essential requirements of ASME B16.34, ASME VIII, PED Directive 97/23/EC and ATEX 94/9/EC.
- Certified firesafe in accordance with API 607 6th Edition / ISO 10497.
- Anti-static design as standard (10Ω under 12 Volt).
- Internally assembled blow-out proof one-piece ball valve stem.
- SS316 trim and operating handles as standard for corrosion resistance.
- High integrity live loaded triple seal ball valve stem sealing system in compliance with ISO 15848 Class AH, suitable for vacuum service and technically emission free.
- Fully encapsulated ball valve seats minimize the risk of extrusion and allows for higher working pressures and temperatures.
- Super finished ball for low operating torque and extended sealing capability.
- Bolted or screwed end connector. Screwed connector threads are fully isolated from process by primary and secondary static seals.
- Lock nut is vibration resistant to avoid working loose.
- Extensive choice of seat materials available, PTFE, Modified PTFE, PCTFE, PVDF, PEEK or Metal seated (Tungsten Carbide or Stellite).
- Certified firesafe heavy duty needle globe vent valve as standard.
- Bolted OS&Y needle globe valve available where threaded connections are not permitted.
- NACE MR0175 / ISO 15156 or MR0103 compliance.

INSTRUMENTATION VALVES

Valve Types

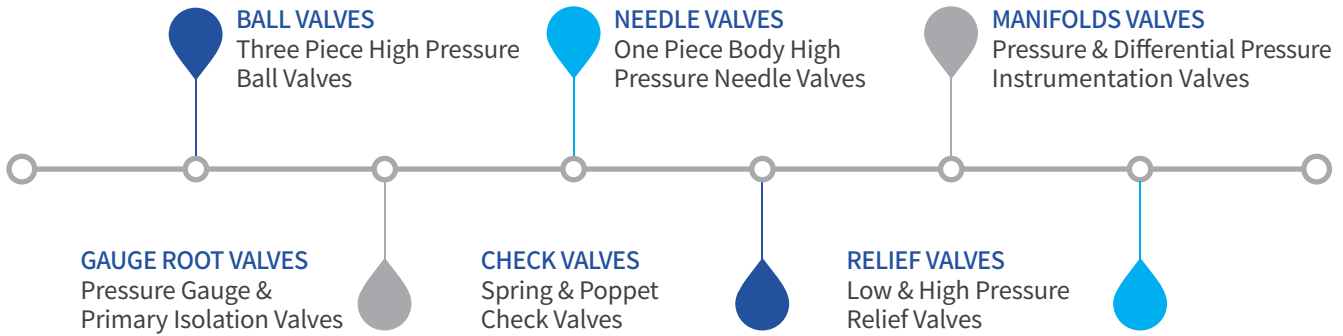

Ball Valves (VB6 Series)

- Pressure rating up to 10,000 psig (690 barg) @ 70°F (21°C)
- Temperature rating from -22°F to 355°F (-30°C to 180°C) with PCTFE seat and from -65°F to 500°F (-54°C to 260°C) with PEEK seat
- 2-way, 3-way, small and compact designs
- Materials available in 316 stainless steel, carbon steel, duplex and alloy 400



Needle Valves (VN6 / VN6H Series)

- Pressure rating up to 10,000 psig (690 barg) @ 100°F (38°C)
- Temperature rating from -65°F to 450°F (-54°C to 232°C) with standard PTFE packing and from -65°F to 1,200°F (-54°C to 649°C) with optional Grafoil packing
- Body materials available in 316 stainless steel, carbon steel, duplex and alloy 400
- Stem thread lubricant is isolated from system fluids



Manifolds Valves (VM Series)

- 2-Valves, 3-Valves, 5-Valves Manifolds designs
- Direct or remote mount manifolds available
- Pressure rating up to 6,000 psig (414 barg) @ 100°F (38°C)
- Temperature rating from -65°F to 1,200°F (-54°C to 649°C) with optional Grafoil packing
- Flange seal grooves meet the design requirements of MSS-SP-99
- Body materials available in 316 stainless steel, carbon steel, and alloy 400



Gauge Root Valves (VGR Series)

- Multi-port designs
- Pressure rating up to 6,000 psig (414 barg) @ 100°F (38°C)
- Temperature rating from -65°F to 450°F (-54°C to 232°C) with standard PTFE packing and from -65°F to 1,200°F (-54°C to 649°C) with optional Grafoil packing
- Body materials available in 316 stainless steel, carbon steel, duplex and alloy 400



Check Valves (VC3 / VC6 / VCO / VCA Series)

- Pressure rating up to 6,000 psig (414 barg) @ 70°F (21°C) - VC6 Series and to 3,000 psig (207 barg) @ 70°F (21°C) - VC3, VCO, VCA Series
- Temperature rating from 375°F (191°C) with FKM seal
- Adjustable and fixed cracking pressures
- Materials available in 316 stainless steel and brass
- Variety of end connections and seal materials
- 100% factory tested for cracking and reseal performance



Relief Valves (VR Series)

- Compact body for installation in small space
- Cracking pressure adjustable externally
- Lock wire capability to maintain pressure relief setting
- Body materials available in 316 stainless steel
- Color label identifies the set pressure range

AUTOMATED VALVES & CONTROL SYSTEMS

Key Features

SWI recognizes the importance of correctly engineered automated products to ensure correct functionality and longevity for reliable performance. In this regard, SWI has implemented rigorous engineering procedures and carries out every element of design, assembly and material selection with consideration to latest industry requirements. Our technical department works with the latest CAD design and sizing software to ensure that our products meet and / or exceed virtually all major operating company standard practices guaranteeing that all actuators are correctly sized and do not overstress the valve throughout its drive train.

Our business is to design, manufacture and supply all types of automated valve and control systems. SWI's philosophy has always been to provide comprehensive, fit - for - purpose and cost effective valve automation products in order to achieve maximum efficiency, safety and reliability to the industry sectors they serve.

To properly support our customers globally and provide correctly engineered and tested automated products, SWI Valve Automation Center center (VAC) has been equipped with some of the most advanced and sophisticated assembly & testing equipments not to be found elsewhere in the industry. Our capabilities and services include:

- Application engineering & design & stress analysis of mounting and drive train components.
- Mounting of electric, pneumatic or hydraulic actuators on valves.
- Panel mounting of control components or installation within control cabinets.
- Assembly of control systems for ESD, BDV, SDV, XV & HIPPS applications.
- Electronic valve torque measurement up to 40,000 Nm.
- Delta P testing up to 484 Kg/cm².
- Hydraulic, pneumatic leak testing of complete assembly.
- High pressure gas testing up to 422 Kg/cm².
- Fugitive emission testing according to ISO 15848.
- Electrical & functional testing of control system; EExd and EEx 'ia' capability.
- Actuator / controls service and repair.
- Supply and retrofitting of actuators & controls.
- Installation, commissioning and on-site service / SAT integration.
- Single warranty for total automated package.





Actuator & Controls

At the heart of any SWI automated valve is the use of high quality heavy duty actuators and controls from some of the most respected manufacturers in the industry.

Quarter turn or linear actuators

- Electric (MOV), pneumatic or hydraulic
- Gas / hydraulic, direct gas, electro / hydraulic
- Fully self-contained hydraulic operated
- On / off or modulating service
- ESD & HIPPS duty

Control systems are generally an integral part of any actuator valve assembly / installation. Control systems can be either mounted directly on the actuator, panel mounted or enclosed within an IP65 weatherproof control cabinet.

- Pneumatic, hydraulic and electrical/PLC control systems
- Partial closure testing: mechanical, simple and SMART
- Positioning / modulating controls with or without backup tank
- Self contained hydraulic power packs
- Control systems for high integrity shutdown ESD
- Gas/hydraulic systems for high pressure gas pipelines
- Direct gas systems for high pressure gas pipelines
- High integrity slam shut control
- ESD valve / actuator condition monitoring

NACE

NACE MR0175 / ISO 15156 or MR0103 compliance available.



QUALITY ASSURANCE

SWI operates under a Quality Assurance system which is approved by Bureau Veritas to ISO 9001/API Q1/KEPIC-MN and SWI is licensed to use the API Monogram in respect of API 6D ball valves. In line with SWI's high reputation for quality of design and manufacture, SWI products have been independently accredited by Bureau Veritas for design, manufacture and materials for complying with the safety requirements of the Directive 97/23/EC (PED).

Major Accreditations



- Quality Management to ISO 9001:2008 & API Q1
- Environment Management to ISO 14001:2004
- Health & Safety Management to OHSAS 18001:2007
- ISO 15848-1 Certification, PED 97 / 23 / EC



- API Monogram (API 6D & API 602)



- IEC 61508:2000 Part 1 & 2 SIL-3



- API 607 6th Ed. / ISO 10497, Fire Safe Test Certificate



- CSA Approval (CRN all regions)



- TR CU (Technical Regulation of Customs Union)



- KEPIC - MN (Nuclear Industry)





Machinery & Equipment

SWI's manufacturing plants are equipped with some of the most technically advanced CNC machineries, automated welding technology and inspection & testing equipments. The 14,500m² Pyeongtaek manufacturing plant has some of the largest CNC horizontal and vertical boring/machining centers to be found in the industry with full CAD/CAM capabilities, automatic tool change and tool wear compensation technology for precision machining of valve bodies and parts. Continuous investment in new and advanced machinery guarantees our clients with the highest levels in quality of manufacture.



Production Testing

SWI has specialized test equipments to perform virtually any required test including full functionality DP testing of valve/actuator assemblies. In-house testing capabilities include hydraulic & pneumatic testing, high pressure gas testing up to 6000 psig, cryogenic testing down to minus 196°C, vacuum testing, fugitive emission testing, thermal cycle testing and electronic torque measurement.



Weld Overlay Technology

SWI's fully automated robotic welding system offers a cost effective solution compared to solid corrosion resistant alloys for valves 8" and larger. Valve bodies, balls, stems & trunnions may all be overlaid with corrosion resistant alloys such as 25% Cr Duplex or Inconel 625. Where highly corrosive or erosive applications are involved, the life expectancy of a valve can be considerably extended by the application of local weld overlay to critical seal areas or full internal cladding to valve internal/process wetted surfaces.



Painting Shop

SWI painting shop includes automatic shot blasting facility, auto-conveyer and 40M drying oven with full segregation of carbon steel from stainless steel and is capable of handling all sizes from 1/2" to 48".

Our integrated painting system is capable of handling all types of painting requirements including heat resistant painting and painting for on-shore & off-shore projects. Furthermore, our shop incorporates Bell Electrostatic Coating System in order to maintain consistent film thickness. In order to ensure the quality of our painting work, SWI has industry standard measuring equipments which can perform C.N.S.Test, Profile Film (O-Film), Wet-Dry Film Thickness, Cleanliness Test, Solt Test, MEK Test and Pull-Off Test.



POLICY STATEMENT

SWI's Key Principles Relating to Environment, Health and Safety Policy

SWI places utmost priority in promoting respect for the environment and health and safety at work of all employees in order to ensure long-term sustainability of the business.

All SWI employees, in accordance with their skills and their role, are compelled to integrate in this policy in their business processes and to be actively involved in the growth of the management system with suggestions for improvement.



Primary Industries Served

SWI stands for three values - quality, innovation and service. We know the world's oil, chemical, petrochemical and process industries require precision flow control products. We have dedicated ourselves to supplying that need with an extensive range of industrial valves, manufactured in our own factories and designed for environmental sensitivity.



- Offshore / Onshore Oil & Gas



- Chemical, Petrochemical & Allied Process



- Power Plant



- Liquefied Natural Gas

Manufacturing Philosophy

SWI's unrelenting commitment to quality, reliability and customer satisfaction is a significant part of our company philosophy. In line with this commitment, SWI sources all of the major materials and parts only from within South Korea. Also, we do not outsource any manufacturing; all of our products are manufactured at one of our two state-of-the-art plants under our own brand name "SWI" – the very name that can be trusted to provide "Reliable Performance in Extreme Conditions".

Global Presence

- Two specialized production facilities in South Korea
- Subsidiary company in Houston, Texas, for stocking and distribution
- Worldwide network of agents, stocking distributors and service shops

Forged G/G/C, Bellows Seal, Metal Seated, Cryogenic Ball and DBB Valves	Extensive List of	Proven Track Record including Numerous	Forging / Casting Sourcing & Manufacturing
Wide Range of Products	Major End User Approvals	High Profile Off-shore Projects	100% done in South Korea

Contact Information

SWI Head Office & Plant 1

91-9 Beolmal-ro, Dongan-gu, Anyang-si, Gyeonggi-do, South Korea
 Tel : +82 31 421 1831~3 Fax : +82 31 421 1834

Seoghoon Lee - Sales & Marketing / Director
 shlee@swivalve.com

Will Chough - Sales & Marketing / General Manager
 whc@swivalve.com

Gene Oh - Operations / Managing Director
 goh@swivalve.com

Plant 2

51 Goryeom-gil, Cheongbuk-myeon, Pyeongtaek-si, Gyeonggi-do, South Korea
 Tel : +82 31 684 2981~3 Fax : +82 31 684 2984

Houston Office

Ronnie Kim - Head of U.S. Sales
 Tel : +1 713 702 2864 rkim@swivalves.com

Malcolm Gilchrist - Technical & Engineered Products / Director
 mgilchrist@swivalves.com

Los Angeles Office

Keith Pritchard - General Sales Manager
 Tel : +1 562 884 8247
 kapritchard@verizon.net



Forged Steel Valves



Cryogenic Service Valves



Bellows Seal Valves



High Integrity Floating Ball Valves



Trunnion Mounted Ball Valves



Top Entry Trunnion Ball Valves

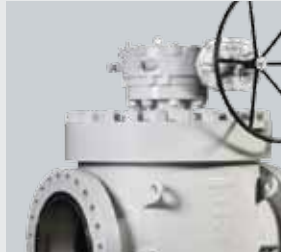

Automation Valves



Triple Offset Butterfly Valves



Positive Isolation Block & Bleed Valves



Instrumentation Valves



HEAD OFFICE & PLANT 1

SWI Valve Co., Ltd.
91-9 Beolmal-ro, Dongan-gu
Anyang-si, Gyeonggi-do
KOREA

Tel : +82 31 421 1831~3
Fax : +82 31 421 1834
www.swivalve.com

PLANT 2

SWI Valve Co., Ltd.
51 Goryeom-gil, Cheongbuk-myeon
Pyeongtaek-si, Gyeonggi-do
KOREA

Tel : +82 31 684 2981~3
Fax : +82 31 684 2984

USA OFFICE

SWI Valve International, LLC
13207 Stafford Rd., Suite 400
Missouri City, TX 77489
USA

Tel : +1 713 266 7033
Fax : +1 281 261 7507