



EL-O-MATIC

Pneumatic & Electric Actuator Product Guide

System
Compatible
Products for
Worldwide
Flow Control



EL-O-MATIC



We continue to grow as a customer-focused global resource that provides the best value in valve automation products.

We also remain committed to providing our customers with a wide range of cost effective valve automation solutions that are compatible with international valve and actuation standards.

Our aggressive approach to product R&D, manufacturing, QC, and global distribution allow us to provide high quality and outstanding customer service on a wide range of worldwide projects in the chemical, pharmaceutical, petroleum, offshore, mining, HVAC, pulp & paper, power, gas transmission, water and wastewater industries.

Contents

Page

Pneumatic Products

E&P Series Rack and Pinion Rotary Actuators 3-9

PosiFlex™ Integrated Valve Positioning System 10-11

Electric Products

ELS, EL and EL Extended Series Rotary Actuators 12-16

ELQ Series “Modular” Rotary Actuators 17-19

Warranty

All EL-O-MATIC products carry our standard warranty, 12 months from date of installation or 18 months from date of purchase.

E&P Series Pneumatic Rack and Pinion Rotary Actuators

Outstanding Performance Under All Types of Continuous Process Conditions

For applications involving extreme temperature ranges or corrosive chemicals, to periodic opening or closing of a valve or hundreds of cycles 24 hours a day, pneumatic actuators are required to operate flawlessly under all types of continuous process conditions.

EL-O-MATIC E&P Series Pneumatic Actuators offer the high quality and reliable performance needed to keep your process up and running with little or no process downtime and lost revenue due to shutdown.

Available in 24 double acting and spring return models from 40 to 120 psig air supply, E&P Series Pneumatic Actuators feature a compact, dual opposed, patented balanced piston design and guide band suspension system for optimum performance and long service life.

NAMUR, VDI/VDE 3845 solenoid, positioner, switch mounting, and a splined alloy 70-75 drive shaft with removable drive inserts provide universal accessory and valve mounting. Dual stroke adjustment is also offered on all E Series actuator models.

Integrated control options include manual override, PosiFlex™ positioning system, limit switches, solenoid valves, and breather blocks. Special actuator options may be supplied upon application.

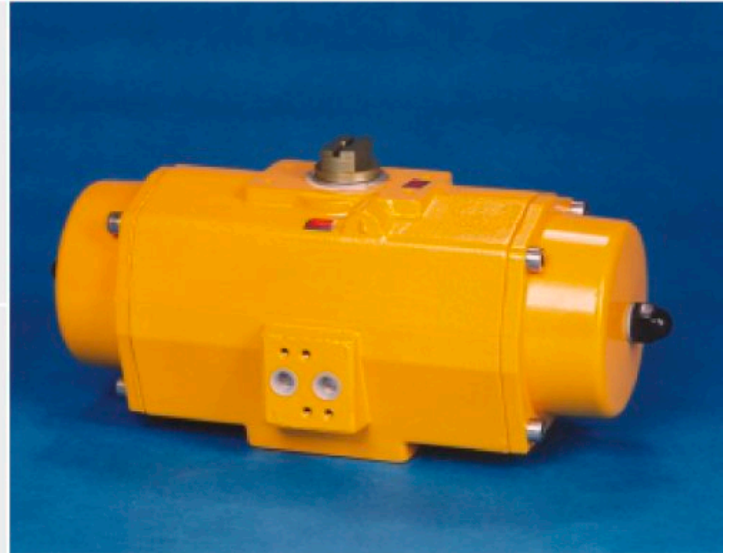

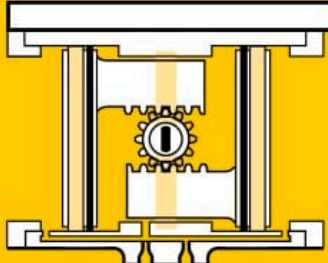
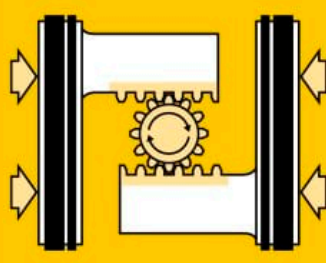
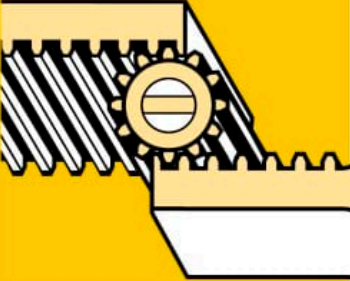
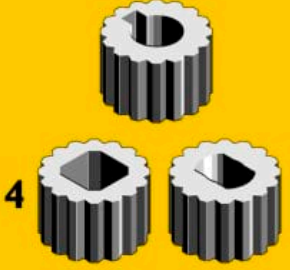
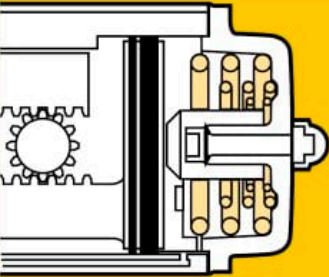
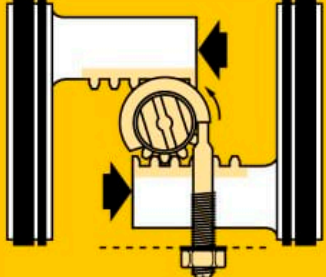
			
<p>High Quality Features Designed to Provide High Cycle, Trouble-Free Life</p>	<p>Three Point Suspension System</p> <ul style="list-style-type: none"> • Piston guide bands provide a low friction bearing surface for piston alignment and rack support • Elimination of metal-to-metal contact between pistons and cylinder wall reduces friction for outstanding cycle life, smooth piston travel, and maximum power 	<p>Dual Opposed, Patented Balanced Piston Design</p> <ul style="list-style-type: none"> • Three equally spaced bearing surfaces are cast into each piston to support and guide the piston for smooth operation • Transfer of maximum power along the central guide band at point of rack and pinion engagement results in even distribution of bearing loads, optimum gear engagement, and elimination of piston tilting 	<p>Alloy 70-75 Drive Shaft</p> <ul style="list-style-type: none"> • Lightweight, high performance aluminum alloy drive shaft ensures precision rack and pinion engagement • Blowout-proof shaft is fitted with inserts to provide direct mounting to valves without brackets or couplings
<p>Removable “Splined” Drive Inserts</p> <ul style="list-style-type: none"> • “Splined” Alloy 70-75 shaft has changeable drive inserts for universal mounting to a wide range of valves without the need for brackets or couplings • Drive inserts can be supplied for virtually all forms of valve shafts: Squares, Double Ds and Key Drives 	<p>Multiple Spring Concept</p> <ul style="list-style-type: none"> • Off-the-shelf availability of a multiple spring design means actuators are available for 40-120 psig supply air requirements • Equal spring force is applied to each piston enhancing actuator life—conversion from double acting to spring return is simple and safe 	<p>Dual Stroke Adjustment</p> <ul style="list-style-type: none"> • Is available on E Series spring return or double acting models • Allows stroke adjustment at both the outbound opening and inbound closing stroke • Rotating collar reduces side loading 	
			

"splined" drive inserts (left)

NAMUR shaft and air supply connections (right)



Safe In-Field Operation with Minimal Maintenance or Downtime

E&P Series Pneumatic Rotary Actuators are available in double acting or spring return models and are relatively lightweight due to their compact rack and pinion construction. They are designed so that there are no external moving parts except for a topshaft or a position indicator. This makes them safe, easy to install, and keeps maintenance to a minimum. Both E&P Series spring return actuators are also inherently "fail safe". In the event of a sudden air pressure loss the actuator automatically returns to its fail-safe position. A variety of spring return packages provides exactly the right choice for any application.

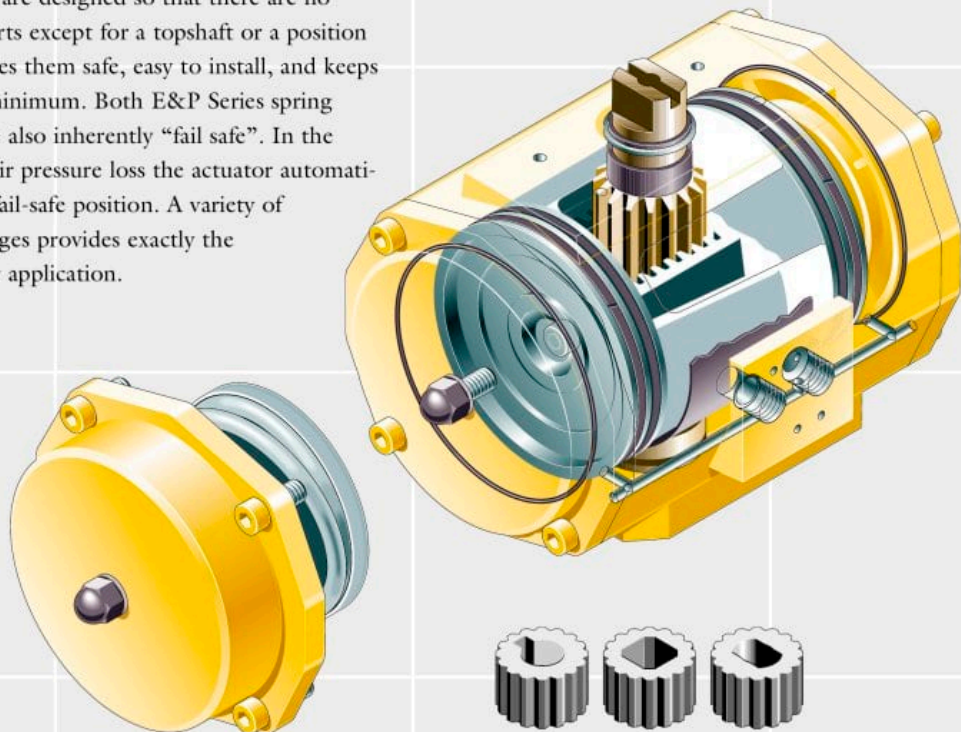



A Complete Choice of Accessories for Advanced Monitoring and Control Applications

Limit Switch Boxes HD

To signal the open/closed position of the valve—usually in on/off control applications. Standard unit contains two SPDT snap-acting switches that are independently adjustable. CSA Explosion-proof approval, Class I and II, Div. I Groups ABCD and EFG, NEMA 4.

Solenoid

For actuator control via an electrical signal.

Manual Override

To open and close the valve manually.



Breather Block

To prevent contaminants from entering a spring return actuator.

180° Actuation

Extended rotation for multi-ported valves. Available in 2 position, 3 position, double acting, and spring return versions.



Block & Vent Valve

To isolate the actuator from its air supply and vent it to make it safe for local service.

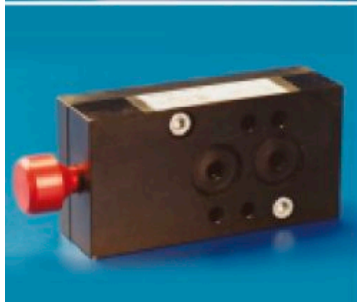

NOTE: For complete information regarding actuator and accessory specifications, data sheets are available for download from www.El-O-Matic.com.

Available Models and Sizing Data

E&P Series Pneumatic Rotary Actuators are available in twelve (12) single acting and twelve (12) double acting models.

180° Dual Stroke Adjustment (DSA), Caustic Soda Resistant (CSR) high or low temperature and fast-acting models are also available.

Complete sizing data for all major valve manufacturers is on file and available from EL-O-MATIC's in-house database to ensure proper selection of the right actuator for the right valve.

Typical Applications

E&P Series Pneumatic Rotary Actuators can be used with ball, plug, or butterfly valves for on/off to continuous process control.

While choice of a particular actuator type depends in part upon the application, the most important selection criteria remains torque. E&P Series Actuators cover a torque range from 80 to 40,000 lb.in.

Special versions are also available for offshore and hygienic applications and can be operated by gas or oil.

Specifications

Operating Pressure	(90° models) 40 to 120 psig (spring return) 20 to 120 psig (double acting)
	(180° models) 80 psig max. pressure (except E12)
Temperature	(standard) -4 to 175°F (-20 to 80°C) (optional) -4 to 250°F (-20 to 121°C) -40 to 175°F (-40 to 80°C)
Media	Air dry or lubricated; noncorrosive gas
Rotation	91.5° (96°-3° clockwise to +3° counterclockwise—DSA model)
Materials	casing: aluminum alloy shaft: 70-75 aluminum alloy
Finish	Polyester non-TGIC based powder coating
Life	Up to one million cycles, depending on application

Standards

E&P Series Pneumatic Rotary Actuators are manufactured in accordance with ISO 9001 and also comply with the following international standards:

- NAMUR, VDI/VDE 3845
- DIN 3337
- ISO 5211



Dimensions

Dim.	E Series										P Series		
	E 12	E 25	E 40	E 65	E 100	E 200	E 350	E 600	E 950	E 1600	P 2500	P 4000	
A DA	6.26	7.09	7.83	8.70	11.14	12.01	15.24	16.69	20.31	14.88	19.76		
B SR	6.77	8.03	9.80	10.51	14.17	15.24	18.78	20.35	25.08	22.44	32.83		
C	3.15	3.66	4.13	4.65	5.63	7.13	8.66	10.20	11.69	14.02	14.96		
D	0.79	0.79	0.79	0.79	0.79	0.79	1.18	1.18	1.18	1.18	1.18		
E	0.63	0.87	0.87	0.87	1.42	1.42	2.17	2.17	2.52	2.17	2.52		
E2	0.91	1.18	1.18	1.18	1.77	1.77	2.56	2.56	2.95	2.56	3.15		
F	0.39	0.55	0.55	0.55	0.75	0.75	1.42	1.42	1.42	1.42	1.42		
G	0.47	0.47	0.47	0.47	0.47	0.47	0.39	0.39	0.39	0.39	0.39		
H	2.91	3.39	3.86	4.25	5.04	6.81	8.15	9.09	10.43	13.78	14.96		
I	1.81	2.09	2.26	2.48	2.87	3.71	4.45	4.96	5.59	7.28	7.87		
J	1.26	1.32	1.54	1.59	1.99	2.85	3.33	4.15	4.74	7.01	7.48		
K	0.94	1.30	1.30	1.50	2.17	2.17	2.68	2.95	3.74	3.35	4.72		
M1	1.36	1.36	1.36	1.36	1.97	1.97	2.05	2.52	3.23	2.60	3.03		
M2	-	-	-	-	1.06	1.46	-	-	-	-	-		
M3	0.669	0.669	0.669	0.787	1.161	1.161	1.161	1.949	2.303	-	-		
N	0.04	0.04	0.04	0.06	0.06	0.06	0.06	0.06	0.12	0.12	0.06		
O max.	0.437	0.556	0.556	0.753	0.871	1.068	1.068	1.424	1.817	1.817	2.173		
O min.	0.433	0.551	0.551	0.748	0.866	1.063	1.063	1.417	1.811	1.811	2.165		
P	0.555	0.713	0.713	0.992	1.110	1.425	1.425	1.898	2.370	2.370	2.843		
P1	0.555	0.713	0.831	0.909	1.303	1.303	1.437	1.909	2.382	-	-		
P2	-	-	-	0.988	1.264	1.264	-	-	-	-	-		
R	2.05	2.56	2.76	2.76	3.54	4.49	4.88	5.12	6.06	6.69	6.69		
R1	1.97	1.97	1.97	2.36	2.36	2.36	3.54	3.54	4.92	6.30	6.30		
R2	-	-	-	-	-	-	-	-	5.20	-	10.31		
S	2.05	2.56	2.76	2.76	3.54	4.49	4.88	5.59	11.02	11.42	11.42		
S1	3.94	3.94	3.94	3.94	3.94	3.94	6.69	6.69	8.27	9.65	9.65		
T	-	-	-	-	-	-	-	-	9.236	9.236	-		
T1	3.150	3.150	3.150	3.150	3.150	3.150	5.118	5.118	5.118	5.118	5.118		
U	-	-	-	-	-	-	-	-	3.827	3.827	-		
U1	1.181	1.181	1.181	1.181	1.181	1.181	1.181	1.181	1.181	1.181	1.181		
V	F03	F05	F05	F05	F07	F07	F12	F14	F16	F16	F16		
V1	1.417	1.969	1.969	1.969	2.756	2.756	4.016	4.016	6.496	6.496	6.496		
W	10- 1/4"	1/4"	1/4"	1/4"	5/16"	5/16"	3/8"	3/8"	3/4"	3/4"	3/4"		
W1	24 x .31	20x.39	20x.39	20x.39	18x.39	18x.39	16x.63	16x.63	10x.114	10x.114	10x.114		
W2	F05	F07	F07	F07	F10	F10	F12	F14	-	-	F25		
W1	1.969	2.756	2.756	2.756	4.016	4.016	4.921	5.512	-	-	10.000		
W2	1/4"- 20x.39	5/16"- 18x.39	5/16"- 18x.39	5/16"- 18x.39	3/8"- 16x.63	3/8"- 16x.63	1/2"- 13x.79	5/8"- 11x.98	-	-	5/8"- 11x.98		
W2	-	-	-	-	-	-	-	-	5/8"- 11x.98	5/8"- 11x.98	-		

For E12 dimensions see A111031.02

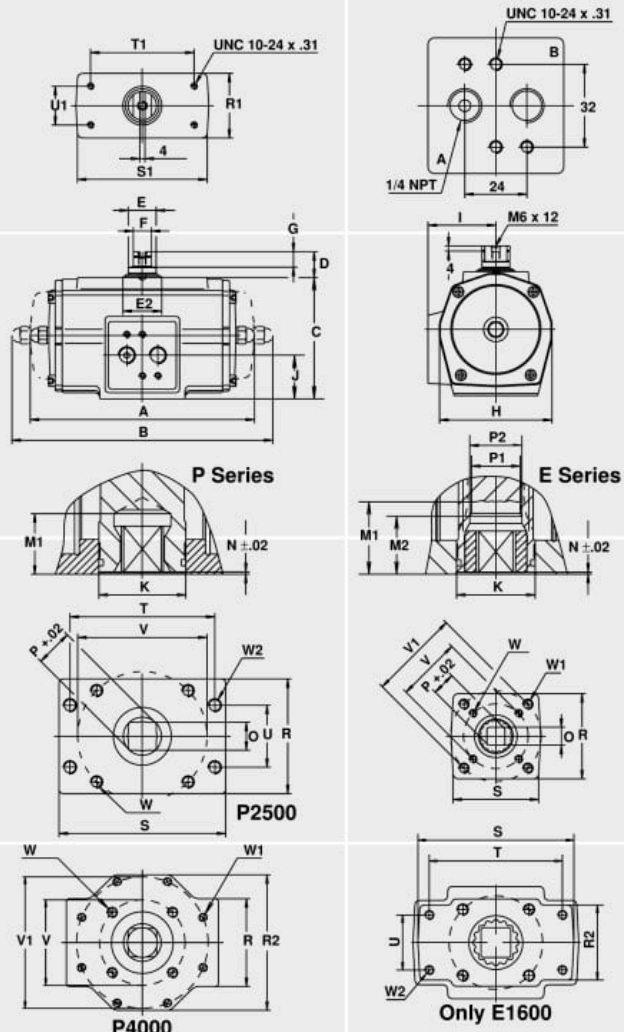

Technical Data

Model		E12	E25	E40	E65	E100	E200	E350	E600	E950	E1600	P2500	P4000
Bore	inch	1.8	2.2	2.8	3.1	3.6	4.3	5.7	6.9	7.9	9.1	11.8	12.8
Stroke	inch	0.5	0.6	0.7	0.9	1.0	1.5	1.5	1.7	2.0	2.5	2.2	3.2
Weight:	Double acting	lb.	1.3	2.9	4.0	5.3	6.8	12.8	22.9	42.8	58.2	94.1	125
	Spring return	lb.	1.5	3.7	5.3	7.9	10.1	20.1	37.3	60.8	85.1	145.1	194
Operating time	sec.	0.4	0.5	0.7	1.1	1.2	2.3	3.6	4.5	5.4	6.9	7	12
Air consumption	port A stroke	3.1	6.1	9.8	20.1	21.4	49	110	177	287	445	488	824
At 1 atm (cu./in.)	port B stroke	3.7	6.7	13.4	22.0	29.9	61	116	189	299	488	568	1.068

“E” & “P” Series Double Acting Torque (lb.in.) vs. Supply Pressure (psig)

Model	Torque of double acting actuators (lb.in.)												
	Supply pressure (psi)												
	30	35	40	45	50	55	60	70	75	80	90	100	120
ED 12	43.9	51.4	58.9	66.4	73.9	81.4	88.9	104	111	119	134	149	179
ED 25	81.4	95.3	109	123	137	151	165	193	206	220	248	276	332
ED 40	153	179	205	231	257	283	309	361	387	413	466	518	622
ED 65	233	272	312	352	392	431	471	551	590	630	709	789	948
ED 100	344	402	461	520	578	637	696	813	872	930	1048	1165	1400
ED 200	754	883	1011	1140	1269	1398	1527	1784	1913	2042	2299	2557	3072
ED 350	1310	1534	1757	1981	2205	2428	2652	3100	3323	3547	3994	4442	5337
ED 600	2226	2606	2986	3366	3747	4127	4507	5267	5647	6028	6788	7548	9069
ED 950	3323	3890	4458	5025	5593	6160	6728	7862	8430	8997	10132	11267	13537
ED 1600	5493	6431	7369	8307	9245	10183	11121	12998	13936	14874	16750	18626	22379

Model	Torque of double acting actuators (lb.in.)												
	Supply pressure (psi)												
	30	35	40	45	50	55	60	70	75	80	90	100	120
PD 2500	8774	10273	11825	13270	14768	16267	17847	20858	22363	23869	26880	29891	35912
PD 4000	14874	17414	19962	22495	25035	27576	30127	35210	37751	40293	45375	50458	60623

PosiFlex™ Integrated Valve Positioning System

Advanced Features Designed to Provide a High Degree of Control Flexibility with Less Maintenance

F10 Series Pneumatic and F20 Series Electro/Pneumatic Positioners

- Durable, corrosion-resistant aluminum NEMA 4X (IP65) housing
- Simple, trouble-free, expandable modular design
- External span and zero setting for fast, easy setup and adjustment of control functions (F10 only)
- 3 lobe cam for linear, quick opening, and equal percentage characteristics to cover all standard ranges and stroke lengths (F10 only)
- Electronic control for easy calibration (F20 only)
- Flexibility for use with single or double acting rotary or linear actuators



Advanced Control and Communication Capability for Today's Intelligent Control Systems

Today's process control systems are high quality, reliable, intelligent—and extremely dependent upon timely information received from instruments in the field. In turn, each instrument must respond accurately to feedback “instructions” received from the control system.

Positioners play a vital part in this communications link through quick and efficient signal conversion, and response in regulating valve position as part of the control process.

The PosiFlex Integrated Valve Positioning System, through a series of compact modular components, provides control of all EL-O-MATIC and other rotary actuators.

PosiFlex Pneumatic Positioners, Electro/Pneumatic Positioners and Limit Switches, with NAMUR, VDI/VDE 3845 or special mounting accessories, can also be used as separate control instruments for any spring return or double acting actuator.

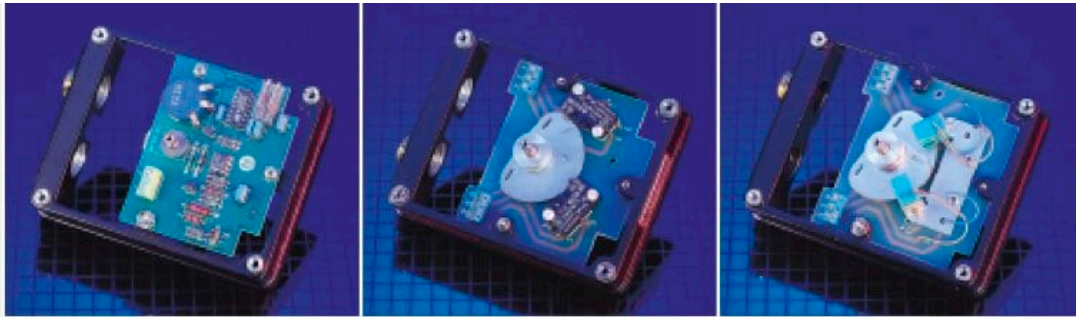

Modular Integrated and Exterior Mounted Accessories to Satisfy Virtually Any Control Requirement

Integrated Options

Mechanical Limit Switches

Two precision 11 ampere SPDT mechanical V3 switches for end of travel indication from 0-180° of rotation.

Electronic Proximity Switches

Two precision 2-wire or 3-wire electronic proximity switches for end of travel indication from 0-180° of rotation.

Potentiometer

For continuous resistive signal feedback on valve position.

Position Transmitter

To provide a reliable 4-20 mA feedback signal verifying valve position.

Exterior Mounted Options

Gauge Block

Compact manifold with durable aluminum cased gauges for continuous indication of the input and output air pressure of the actuator and positioner.

Dome Indicator

For visual indication of actuator position

Explosion Proof I/P Adaptor

For mounting of an FM/CSA approved explosion proof I/P transducer to meet Class I, II, and III requirements.

NAMUR, VDI/VDE 3845, and Special Mounting Accessories

For positioner mounting on any actuator.

NOTE: For complete information regarding the PosiFlex Integrated Valve Positioning System and accessories, please ask for the Process Direct Integrated Actuator Control Components brochure.

Specifications

Supply Pressure	20 to 125 psig
Operation	universal for use with single or double acting rotary or linear actuators
Mounting	NAMUR, VDI/VDE 3845
Materials	casing: aluminum
Finish	Polyester powder coated

Technical Data

Model	F10	F20
Function	Pneumatic	Electro/pneumatic
Input Ranges	3-15, 3-9, 9-15 psi	4-20, 4-12, 12-20 mA
Rotation	24-180°	24-180°
Sensitivity	<0.1%	<0.1%
Hysteresis	<0.6%	<0.6%
Linearity	<1.0%	<1.0%
Air Consumption	0.6 SCFM	0.4 SCFM
Flow Capacity	7.4 SCFM	7.4 SCFM
Connections	1/4" NPT	1/4" NPT supply 1/2" NPT electrical
Temperature Minimum	-4 to 176° F	-4 to 176° F
Actuator Volume	6.1 in ³	6.1 in ³

ELS, EL, and EL Extended Series Electric Actuators



Optimum Performance Under the Most Demanding On/Off and Regulating Conditions

From aggressive chemicals to use in hostile environments, electric actuators must provide optimum performance under the most demanding operating conditions.

EL-O-MATIC ELS, EL, and EL Extended Series Electric Actuators meet this challenge through a superior design that is field-proven over a wide range of process applications and uses high quality, corrosion-resistant aluminum alloy, stainless steel, and bronze materials for internal components and housings.

A Choice of Three Designs for Small, Medium or Large-Size Valves

ELS Series

ELS Series Electric Actuators are available in two (2) models, produce up to 221 lb.in. of torque and utilize a spur gear drive system effective for use with 2-way and 3-way ball valves.

Standard operating features include cam operated limit switches from 0° to 270° of rotation and 50% duty rating.

Options include two extra switches for auxiliary circuit control, feedback potentiometers, MOD positioner (ELS 25 only) for position control, compartment heater, low voltage DC motors for vehicular applications and special paint or labeling.

EL Series

EL Series Electric Actuators are available in the seven (7) models with torque outputs to 7,080 lb.in. and utilize a self-locking multiple reduction worm gear system for tight quarter turn positioning control. EL Series Actuators have a 30% duty cycle.

Standard, integrated features on all models include dome position indicator, manual override, heater, torque switches (except EL55), and mechanical travel stops.

Available options include positioners, position transmitters, low temperature, local control, speed control, extra switches, and multi-turn models.

EL Extended Series

EL Extended Series Electric Actuators are available in three (3) models, produce up to 22,125 lb.in. of torque and are ideal for use with butterfly and larger type valves.

A self-locking worm gear system, lubed-for-life gear case, ball bearing motor, anti-condensation heater, precision adjustable limit switch cams, and hermetically enclosed mechanical position indicator result in an all-encompassing actuator that provides on/off valve positioning service, extra long life, low maintenance, and maximum corrosion resistance. These units feature a 30% duty cycle.

Integrated control options include extra switches (up to 6), electronic speed control, potentiometer, multi-position control, 180° rotation (greater angles available), 4-20 mA position transmitter, 4-20 mA positioner control local control station, and plug and socket connection.

worm and worm gear drives



Outstanding Features to Meet Most In-Field Operating Requirements

ELS Series

- Compact, lightweight, fully gasketed NEMA 4X housing (500 hour salt spray tested)
- Spur gear system designed for 2-way and 3-way ball valves
- Split capacitor fan cooled ball bearing motor with integrated thermostatic overheat protection
- Sealed, maintenance-free gearbox with steel spur gear chain and “double-D” universal output shaft
- Easily adjustable, cam actuated limit switches that cover up to 270° of rotation and provide outputs for position indication

EL Series

- Compact, lightweight durable NEMA 4, 4X, 7, and 9 rated aluminum housings
- Self-locking, multiple reduction worm gear system for tight, quarter turn positioning control
- Rugged, ball bearing motor with auto-reset thermal overload protector available in all common supply voltages
- Hand wheel override for manual valve operation
- Torque switches to protect valve seat from debris damage and provide reserve torque up to the rated maximum (except EL55)
- Cam operated limit switches for in-field adjustment of actuator stroke to valve (factory preset for nominal 90° stroke)
- Highly visible, domed valve position indicator

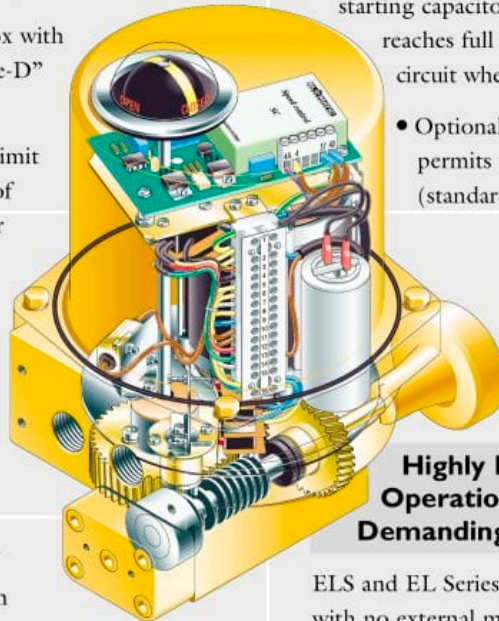

EL Extended Series

- Durable, corrosion-resistant NEMA 4, 4X, 7, and 9 rated aluminum housings (optional NEMA 6)
- Declutchable, easy-to-use spoked hand wheel override for manual operation
- Electromechanical torque regulator/limiter to protect valve seat from debris damage and provide reserve torque up to the rated maximum
- Integral motor centrifugal switch that removes the starting capacitor from the circuit when the motor reaches full speed and returns the capacitor to the circuit when the motor stops (EL2500 only)
- Optional NEMA 6 submersible rating permits use in 40” of seawater for 24 hours (standard on EL2500)

Highly Reliable, Trouble-Free Operation for the Most Demanding Applications

ELS and EL Series Electric Actuators have been designed with no external moving parts for trouble-free, in-field operation and are easily installed on most ball, plug, and butterfly valves through standardized mounting. The electric motor used in all EL actuator designs turns primary and secondary worm gears to engage the final drive shaft. This double worm gear drive system offers two (2) distinct advantages over other designs. First, the actuator is self-locking and second, transmission backlash is negligible. The hand wheel override, which is connected to the second worm gear, can be used to operate the valve manually in case of power failure.



local control (left)

positioner (right)

A Wide Range of Accessories to Accommodate Most In-Field Operating Needs

Additional Switches

For external (or remote) position indication of the actuator.

Speed Control

To regulate actuator cycle time (adjustable).

Potentiometer

Provides a resistive signal for position indication throughout the stroke.

Position Transmitter

For position indication by a 4-20 mA signal throughout the stroke.

Positioner

To regulate the valve between open and closed position via a 4-20 mA or 0-10 VDC signal.

Local Control Station

To operate actuator locally or from a remote location.

NOTE: For complete information regarding electric actuator and accessory specifications, data sheets are available for download from www.El-O-Matic.com.

Available Models and Sizing Data

ELS Series Electric Actuators are available in two (2) models: ELS18 and ELS25

EL Series Electric Actuators are available in seven (7) models: EL55, EL100, EL150, EL200, EL350, EL500, and EL800

EL Extended Series Electric Actuators are available in three (3) models: EL1200, EL1600, and EL2500.

Low, high temperature, and explosion proof models are also available.

Complete sizing data for major valve manufacturers is on file and available from EL-O-MATIC's in-house database to ensure proper selection of the right actuator for the right valve.

Standards

ELS, EL, and Extended Series Electric Actuators are manufactured in accordance with ISO 9001 and comply with the following international standards:

- ISO 5211
- EN55018
- DIN 3337
- EN50082-2
- EN50014
- EN50093
- EN60204
- EN60529

Typical Applications

Electric Actuators are ideal for applications where an air supply is not available, low ambient temperatures limit use of pneumatic actuators, location makes maintenance difficult, or an all electric system is much more flexible and economical than installation of an extensive compressed air network.

ELS Series Actuators are ideal for small ball valves while EL Series Actuators are particularly well suited for use with ball valves, small and medium-sized butterfly valves, and for other quarter turn applications such as dampers and ventilation grids. EL Extended Series actuators are specifically designed and engineered for use with butterfly and larger type valves in marine, wastewater, and other applications.

Technical Data

Model		ELS-18	ELS-25	EL-55	EL-100	EL-150	EL-200	EL-350	EL-500	EL-800	EL-1200	EL-1600	EL-2500	
Torque (Nm)	break	18	25	55	100	150	200	350	500	800	1200	1600	2500	
	run	14	20	20	35	53	70	123	175	280	420	560	875	
Torque (in.lb)	break	160	221	487	885	1,328	1,77	3,098	4,425	7,081	10,621	14,16	22,125	
	run	124	177	177	310	465	620	1,084	1,548	2,478	3,717	4,956	7,744	
Op. Time (S)	50 Hz	6.5	9.5	6	7.5	9	13.5	22	25.5	25.5	25.5	25.5	28	
	60 Hz	5.5	7.5	5	6	7.5	11.5	18	21.5	21.5	21.5	21.5	22.5	
	DC	-	-	5	6.5	8	12	20	23	-	-	-	-	
Current (A)	120/1/60	break	0.55	0.6	1.1	2.9	2.9	2.9	2.9	2.9	4.5	14	14	58
		run	0.45	0.5	0.6	2.1	2.1	2.1	2.1	2.1	2.8	5.8	5.8	8
	220/1/50	break	0.1	0.3	0.6	1.7	1.7	1.7	1.7	1.7	2.3	7	7	27
		run	0.1	0.27	0.5	1.1	1.1	1.1	1.1	1.1	1.8	2.5	2.5	6
	380/3/50	break	-	-	0.4	0.7	0.7	0.7	0.7	0.7	0.9	2.8	2.8	9
		run	-	-	0.2	0.4	0.4	0.4	0.4	0.4	0.54	0.6	0.6	1.5
	460/3/60	break	-	-	0.37	0.63	0.63	0.63	0.63	0.63	0.87	1.1	1.1	2
		run	-	-	0.18	0.45	0.45	0.45	0.45	0.45	0.57	0.72	0.72	1.6
	24Vdc	break	0.8	0.51	5	8	8	8	8	8	-	-	-	-
		run	0.15	0.1	1.9	4.9	4.9	4.9	4.9	4.9	-	-	-	-
	Power consump. (W)	120/1/60	45	25	100	225	225	225	225	225	315	535	535	720
220/1/50		40	65	72	200	200	200	200	200	305	450	450	792	
380/3/50		-	-	80	145	145	145	145	145	165	220	220	560	
460/3/60		-	-	77	180	180	180	180	180	200	266	266	600	
24Vdc		4.8	2.4	45	118	118	118	118	118	-	-	-	-	
Power factor (cos Phi)	120/1/60	-	-	0.87	0.98	0.98	0.98	0.98	0.98	0.93	0.83	0.83	0.74	
	220/1/50	0.82	0.82	0.91	0.82	0.82	0.82	0.82	0.82	0.77	0.92	0.92	0.5	
	380/3/50	-	-	0.54	0.51	0.51	0.51	0.51	0.51	0.47	0.55	0.55	0.67	
	460/3/60	-	-	0.54	0.5	0.5	0.5	0.5	0.5	0.44	0.53	0.53	0.6	
Motor speed (RPM)	50 Hz	1878	1620	1450	1425	1425	1425	1425	1425	1450	1450	1450	1450	
	60 Hz	2328	2040	1725	1725	1725	1725	1725	1725	1725	1725	1725	1725	
	24Vdc/ac	3230	4210	1600	1600	1600	1600	1600	1600	-	-	-	-	
Overall gear ratio		849/1	1070/1	1250/1	700/1	840/1	1316/1	2106/1	2480/1	2480/1	3100/1	3100/1	2600/1	
Capacitor (µF/V)	120/1/60	6.8/250	6.8/250	20/250	36/250	36/250	36/250	36/250	36/250	50/250	100/250	100/250	400/250	
	220/1/50	1.5/400	2/400	8/450	10/450	10/450	10/450	10/450	10/450	16/450	30/450	30/450	100/450	
Weight (Kg)	W-proof	2.2	2.8	6	11	11	16.5	17	25.5	26.4	37	37	75	
	Ex-proof	-	-	8	13	13	18.5	20	28.5	30	37	37	75	
Weight (Lbs)	W-proof	4.3	5.5	13	24	24	36	37.5	56	57	81.5	81.5	165	
	Ex-proof	-	-	17.5	28.5	28.5	40.5	44	62.5	66	81.5	81.5	165	
Duty Cycle		50%	50%	30%	30%	30%	30%	30%	30%	30%	30%	30%	30%	

ELS Series Specifications

Enclosure:	NEMA 4X (CSA approved optional)
Temperature:	-4 to +158°F
Connections:	by 4 point internal terminal strip
Materials:	aluminum base; steel cover, drive spindle, and fastenings
Finish:	zinc plating, two part polyurethane
Life:	100,000 operations minimum
Heater:	10 W, optional
Conduit entry:	1 x 1/2" NPT

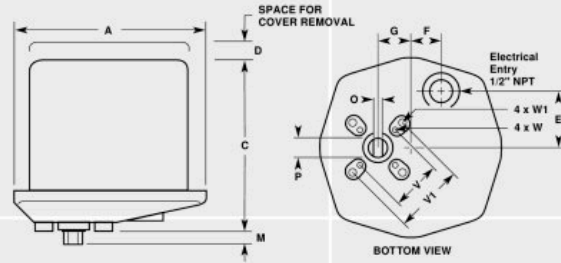

Dimensions

Model	A	C	D	E	F	G	M	O	P	V	VI	W	WI
ELS 18	5.1	4.82	3.3	1.65	0.87	0.92	0.44	0.279	0.437	2.114	-	10.24 UNC x .306	-
ELS 25	6.2	5.3	3.9	1.97	0.79	1.04	0.51	0.393	0.472	1.968	2.756	1/4-20 UNC x .408	5/16-18 UNC x .459

Note: Request for certain options on ELS25 adds 1.85" to cover height.

EL Series Specifications

Enclosure:	NEMA 4X or 4X/7/9 EL55-800 – available in NEMA 6
Temperature:	-4 to +158°F*
Connections:	by 12 to 16 point internal terminal strip
Materials:	see data sheet
Finish:	zinc plate, two part polyurethane
Life:	50,000 operations minimum
Heater:	10 W, standard
Conduit Entry:	EL55 – 150 1/2" NPT EL200 – 800 3/4" NPT

*FM approved explosion proof Model +140°F Max.

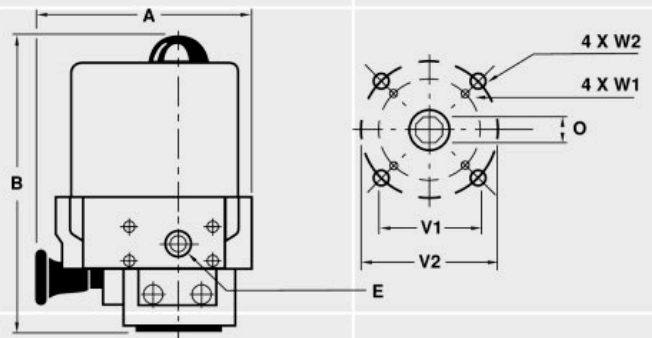

Dimensions

Model	A	B	E	O	V1	V2	W1	W2
EL 20	5.1	6.4	1/2	.435	1.969	-	1/4-20	-
EL 55	7.5	10	1/2	.551	1.969	2.756	1/4-20	5/16-18
EL 100	9.3	11.5	1/2	.748	1.969	2.756	1/4-20	5/16-18
EL 150	9.3	11.5	1/2	.748	1.969	2.756	1/4-20	5/16-18
EL 200	11.6	12.1	3/4	.748	2.756	4.016	5/16-18	3/8-16
EL 350	11.6	12.1	3/4	.748	2.756	4.016	5/16-18	3/8-16
EL 500	12.7	12.5	3/4	1.063	4.016	-	3/8-16	-
EL 800	12.7	14.02	3/4	1.063	4.921	-	1/2-14	-

EL mounting and drive dimensions are to ISO 5211.

EL Extended Series Specifications

Enclosure:	NEMA 4X/7/9
Temperature:	-4 to +158°F
Connections:	By 12 and 16 point internal terminal strip
Materials:	Aluminum cast base and cover, steel drive spindle, and fastenings
Finish:	Two part polyurethane
Life:	50,000 operations minimum
Heater:	20 W, standard
Conduit Entry:	1" NPT 3X

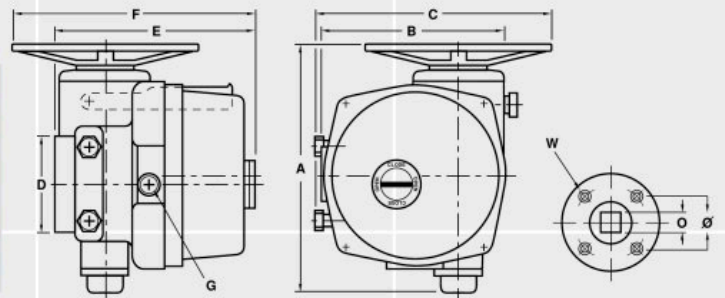

Dimensions

Model	A	B	C	D	E	F	G	O	Ø	W
EL 1200/1600	17.0	11.3	15.2	6.9	15.0	18.3	3/4" 3xPL NPT	1.417	5.510 UNC	4x5/8-11
EL 2500	21.3	15.8	25.2	8.3	19.5	23.2	1" 3xPL	1.811	6.496	4x3/4-10

ELQ Series Electric Actuators



Modularity of Design for Maximum Operating Versatility

Modularity ...the key word that can best be used to describe EL-O-MATIC's ELQ Series electric actuators for quarter turn rotary valves.

From on/off applications to full control or use from one valve to another, ELQ Series Electric Actuators provide maximum operating versatility through easily changed "plug-in" modules designed to accommodate varying operating requirements and "splined" drive inserts for direct mounting to a wide range of valves.

Available in five models from 445 to 7000 lb.in., ELQ Series Actuators feature a highly efficient flex-spline gear system for tight positioning control. Standard features include a manual override, mechanical travel stops, dome position indicator, and NEMA 4X, 6, 7, and 9 housings.

A built-in, multi-voltage capability allows use of the ELQ with most common supply voltages such as 24 VDC, 110 VAC, 220 VAC or 380 VAC 3 Phase. Analog, digital, and bus communications facilitate simple integration into any process automation system.



Optional MOD positioners, speed controls, and position transmitters are available as "plug-in" modules to simplify installation and reduce initial or later upgrade costs.

Unique Features with Highly Cost-Effective Installation, Operation, and Upgrade Benefits

- 100% duty cycle motor for continuous operation
- Built-in, multi-voltage capability for direct connection to most common supply voltages
- Electronic motor control for precise, highly reliable operation
- Optional fieldbus communications provide interoperability between system devices
- "Splined" drive inserts for direct mounting to a wide range of valves
- Easy-to-set mechanical travel stop and limit switches
- Hand wheel override for manual valve operation
- Highly visible, domed valve position indicator
- Compact, lightweight durable construction through use of NEMA 4X, 6, 7, and 9 rated aluminum alloy housings

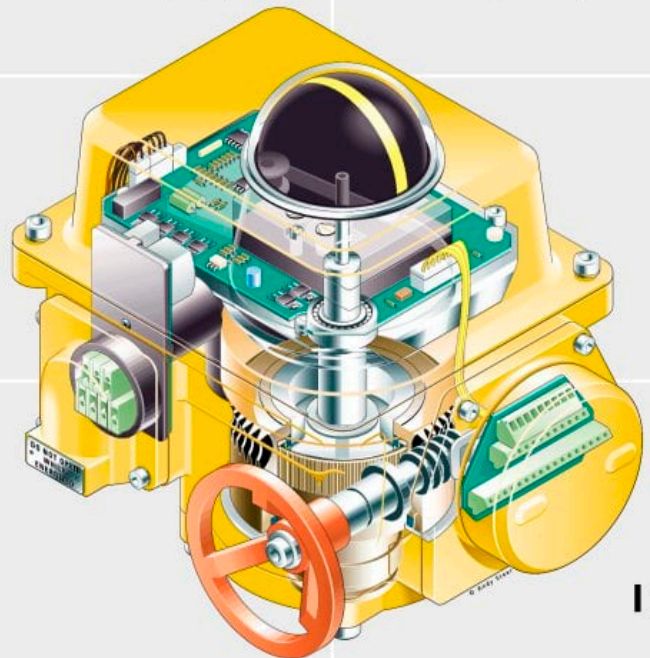

rotatable power entry (left)
terminal compartment with plug connector (right)



Operation Ideally Suited for On/Off to Numerous Full Control Applications

While ideally suited for on/off and modulating applications, the flexibility offered by the ELQ’s numerous operating features and “plug-in” options makes it highly suitable for a wide range of control functions.

Depending upon the desired operating features or application, the ELQ’s optional modules can be simply plugged into the electronic control board—no tools are required. External control signals are sent to the control board via the actuator’s modular terminal compartment.

Should the application parameters change, the terminal compartment along with the plug can be quickly removed and plugged into another ELQ—totally eliminating the time and cost associated with hardwiring the control signals.

The electronic motor utilizes a soft-start principle to avoid high peak loads during starting and ensures smooth running. The actuator has two mechanical stops at 0° and 90° with adjustment bolts that allow adjustment of the setting ± 10°. Factory preset torque is 100% with available torque settings of approximately 50%, 75% or 100% using a jumper.

The limit switch unit is mounted on the control board containing the motor switches and auxiliary limit switches. These switches provide stepless setting with a conical blocking system to prevent drift and are easily set by using a slotted screwdriver.

The ELQ’s high ratio gearing and very high reduction ratio result in a compact, lightweight actuator with very low noise level and virtually no play. The hand-wheel allows for manual or emergency operation and automatically disengages if the motor is running.

Numerous “Plug-In” Options to Simplify Installation and Meet Most In-Field Operating Requirements

Positioner

Controllable via a 4-20 mA or 0-10 VDC signal to regulate position of the valve between the closed and open position.

Position Transmitter

Provides continuous position indication through a 4-20 mA signal proportional to the position of the output shaft.

Communication Card

Interface cards available for Foundation Fieldbus™ or Profibus™ DP bus communication protocols.

Speed Control

To control output shaft speed of the ELQ actuator.

Local Control Station

Allows operation of the actuator locally or from a remote location.

Status Information

Provides feedback information on actuator operating modes including motor status, local/remote indication, and power supply connections.

High Power Limit Switches

For use when switch voltage is higher than 24 V (i.e. 110 or 220 V)

drive inserts



Available Models and Sizing Data

ELQ Series Electric Actuators are available in five models: ELQ100, ELQ200, ELQ300, ELQ500, and ELQ800.

Complete sizing data for all major valve manufacturers is on file and available from EL-O-MATIC's in-house database to ensure proper selection of the right actuator for the right valve.

Typical Applications

The new ELQ Series has been engineered to bridge the gap between electric actuators and today's challenging process automation applications.

In a variety of situations, electric actuators are actually preferable to pneumatic actuators. For example, when there is a large distance between valves, the cost of supplying compressed air is more expensive than laying electric cables. With its wide range of possibilities, the ELQ Series Electric Actuator is also highly suitable for applications where more extensive communication between the control room and actuator is required.

Power supply	AC - 115 V, 230V, or 400 V 50/60 Hz DC - 24V
Control signal	24VDC (±10%)
Limit Switches	2 x SPDT, 500mA at 30 VDC/VAC
Temperature	-4°F (-20°C) to 158°F (70°C), low and high temp versions available on request
Nominal rotation	90°, adjustable limit switches at each end ± 10°
Enclosure	NEMA 4X / IP65 (optional: NEMA 6 / IP67)
External steel parts	Stainless steel
Finish	Two part polyurethane
Heater	Standard 10 Watt
Torque control	Electronic, manually adjustable

Standards

ELQ Series Electric Actuators are manufactured in accordance with ISO 9001 and also comply with the following international standards:

- Water Proof NEMA 4X/IP65 (optional NEMA 6/IP 67)
- Explosion Proof FM, Class I, Div. 1, Groups C & D ATEX, II 2 G EEx d IIB T4
- Flanges ISO 5211 or DIN 3337

positioner option

Performance		ELQ100	ELQ200	ELQ300	ELQ500	ELQ800
Torque (lb.in.)		885	1770	2655	4425	7081
Speed/90° (sec.)	Max. Load	10	14	18	22	36
	No Load	6	8	13	17	28
Current (A) Max.	115 VAC	1	1	1	1.7	1.7
	230 VAC	0.5	0.5	0.5	0.9	0.9
	400 VAC	0.3	0.3	0.3	0.5	0.5
	24 VDC	4.1	4.3	4	5.3	5.1
Power (W) Normal		98	102	96	130	125
Weight (lb.)		29	31	32	62	66

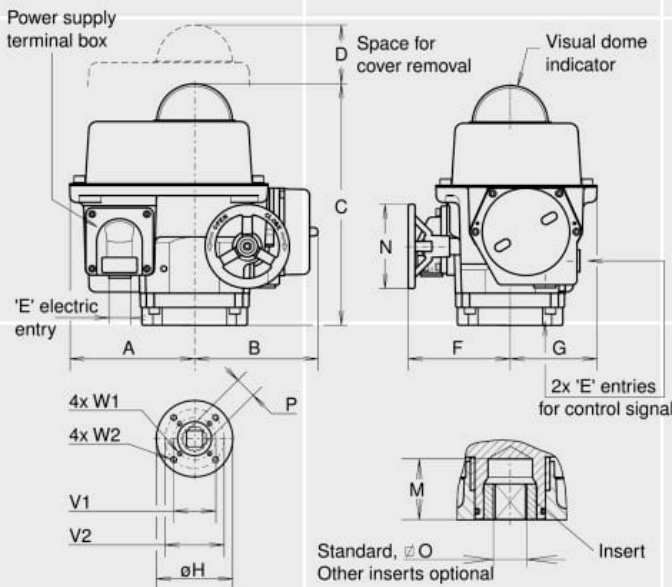
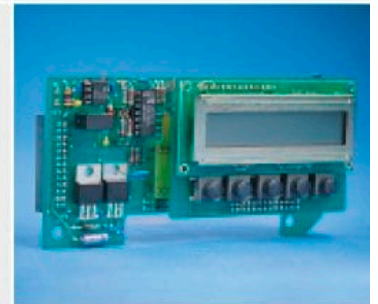

Dim. in In.	ELQ100	ELQ200	ELQ300	ELQ500	ELQ800
A	5.83	5.83	5.83	7.17	7.17
B	5.79	5.79	5.79	7.36	7.36
C	11.30	11.30	11.30	13.19	13.19
CI	10.24	10.24	10.24	12.01	12.01
D	3.94	3.94	3.94	3.94	3.94
E	1/2"NPT	1/2"NPT	1/2"NPT	1/2"NPT	1/2"NPT
F	4.65	6.14	6.14	8.62	10.08
G	4.06	4.06	4.06	5.20	5.20
H	4.92	4.92	4.92	6.89	6.89
M	1.97	1.97	1.97	2.36	2.36
O max.	0.752	0.752	0.871	1.068	1.424
O min.	0.748	0.748	0.866	1.063	1.417
P	0.99	0.99	1.11	1.43	1.90
V1	2.756	2.756	2.756	4.016	4.016
V2	4.016	4.016	4.016	5.512	5.512
W1	5/16-18 x .53	5/16-18 x .53	5/16-18 x .53	3/8-16 x .63	3/8-16 x .63
W2	3/8-16 x .63	3/8-16 x .63	3/8-16 x .63	5/8-11 x .79	5/8-11 x .79

CI: Height of actuator with NEMA 7 cover.

NORTH & SOUTH AMERICA

**Emerson Process Management,
Valve Automation division**

9009 King Palm Drive
Tampa
Florida
33619
United States of America
T +1 813 630 2255
F +1 813 630 9449
Info.El-O-Matic-USA@EmersonProcess.com

SOUTH AFRICA

**Emerson Process Management,
Valve Automation division**

P.O. Box 979
Isando
1600
2 Monteer Road
Isando
South Africa
T +27 11 974 3336
F +27 11 974 7005
salesinfo@elomatic.co.za

SINGAPORE

**Emerson Process Management,
Valve Automation division**

9 Gul Road
#01-02 Singapore 629361
T +65 6501 4600
F +65 6268 0028
Info.ValveAutomation-AP@EmersonProcess.com

EUROPE MIDDLE EAST & AFRICA

**Emerson Process Management,
Valve Automation division**

P.O. Box 223
7550 AE Hengelo (O)
Asveldweg 11
7556 BT Hengelo (O)
The Netherlands
T +31 74 256 10 10
F +31 74 291 09 38
Info.El-O-Matic@EmersonProcess.com

GERMANY

**Emerson Process Management,
Valve Automation division**

Postfach 500155
D-47870 Willich
Siemensring 112
D-47877 Willich
Germany
T +49 2154 499 660
F +49 2154 499 6613
Info.ValveAutomation-BRD@EmersonProcess.com

**Please visit www.El-O-Matic.com
for the latest product information.**

Important: Due to Emerson's continuing commitment to engineered product advancement, data presented herein is subject to change.

EL-O-MATIC® is a registered trademark of EL-O-MATIC International.
PosiFlex™ is a trademark of EL-O-MATIC International.
PROFIBUS™ is a registered trademark of PROFIBUS International.
Foundation Fieldbus® is a registered trademark of Fieldbus Foundation.

Bulletin # 101.00 Rev: 3-06

© 2001 Emerson. All rights reserved. 2.5M/3-06

