

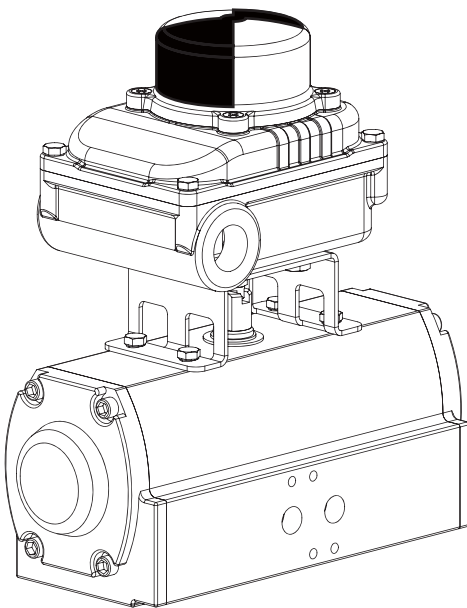

Robust valve position monitor with a good recognizable beacon, various switches and feedback options

Features

- ▶ Weatherproof to IP66 & 67 (optionally IP68)
- ▶ Rugged aluminum die-cast housing
- ▶ Various switches and sensors (available with Honeywell / P&F)
- ▶ NAMUR mounting shaft or fork lever shaft adjustable for a non-NAMUR pneumatic actuator



Options

- ▶ 2 x SPDT mechanical limit switch
- ▶ 4 x SPDT mechanical limit switch
- ▶ 2 x P&F proximity sensor

Specifications

Model	LSB-1000
Protection Class	IP66 & 67 (optionally IP68)
Switches / Sensors	See page 5
Operating Temperature	- 40 ~ +100°C (-40 ~ +212°F)
Electrical Connections	PF 1/2, NPT 1/2, M20 x 1.5, PG13.5
Body Material / Painting	Aluminum die-cast / powdered-coating
Weight	0.8 kg