

Safety-Valve, springloaded

for non-toxic steam and gases, low pressure

Typ 67

Standard version:

Operating temperature

Material: Inlet body

Typ 67.2: 1.4404

-60°C to 150°C

Connections:

Screwed connection: DIN ISO 228

soft seated
see techn. appendix: KWD-1

Approvals:

Pressure Equipment Directive: 97/23/EG
Declaration of Conformity



TÜV - Approval:

VdTÜV-leaflet AD 2000-leaflet A 2

TÜV • SV • XX-885 • do • D/G • α_w • p

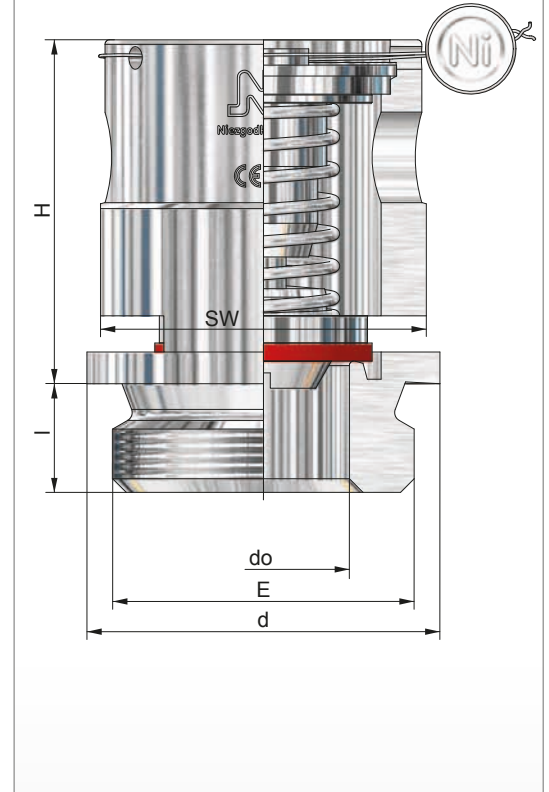

head E
G1 - male



head D
G1 - male



head C
G1 - male



head C
G1 - female

Size	Inlet				Outlet A	Dimensions			Height 'H' for head			Coefficient		Set pressure		Weight ~ [kg]
	E	d	l (G)	l (Muffe)		SW	do		C	D	E	D/G	α _w max.	p min.	p max.	
	[mm]	[mm]	[mm]	[mm]	[mm]	[mm]	[mm]	[mm]	[mm]	[mm]	[mm]		[bar(g)]	[bar(g)]		
1	39	12	12	free	36	19		38	46	54	0,31		0,05	3,0	0,25	

other design on request

Safety-Valve, springloaded

for non-toxic steam and gases, low pressure

Typ 67

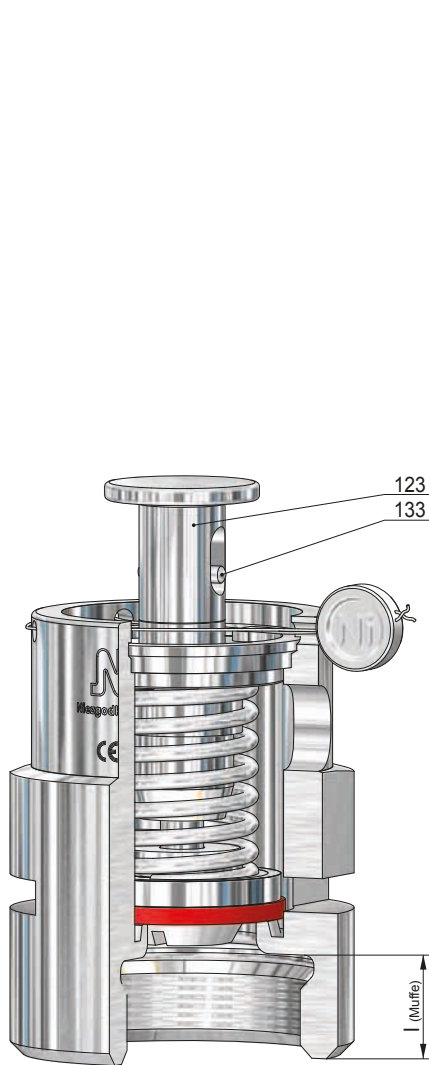

G1 - female
head E, liftable

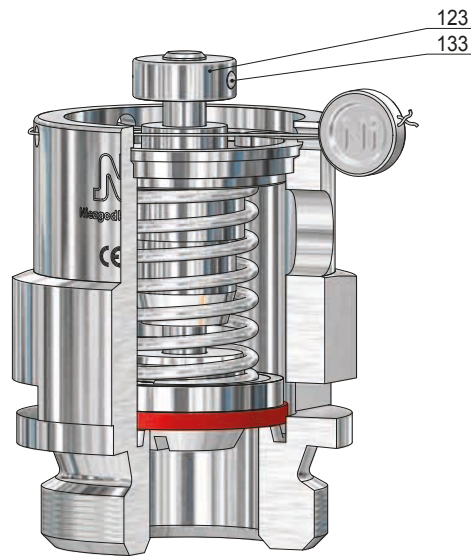

G1 - male
head D, liftable

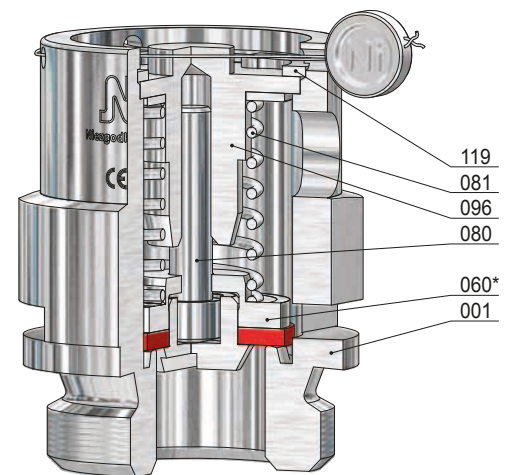

G1 - male
head C

Item	Piece	Description	Item	Piece	Description
001	1	inlet body			
060 *	1	disc, complete			
062	1	soft sealing			
064	1	disc screw			
080	1	spindle			
081	1	spring			
096	1	spring guide			
119	1	locking ring			
123	1	lifting button			
133	1	groove pin			

* expendable parts