

R 101

Construction and function of the R 101

The R 101 is a gas pressure regulator, which ensures the constant outlet pressure given a varying inlet pressure or flow capacity.

The gas flows through the regulator housing (cutview R 101) in arrow direction. The main diaphragm is actuated via an impulse line from the outlet side by pressure. The required outlet pressure is adjusted at the spring.

The valve remains open as long as the outlet pressure is below the seat value. When reaching the set point the regulator valve closes.

The measure work is directly mounted and operates independent from the inlet pressure.

R 101 with single seat valve

Nominal diameters: DN 25, 40, 50, 65, 100



Wheel in use materials

Housing:	Silumin casting
Diaphragm cap:	Silumin casting
Internal parts:	stainless
Diaphragms:	50 NBR
valve discs:	50 NBR, vulcanized

Connections

DN 25 - 100
Flange PN 16 DIN EN 1092-4

R 101 in a gas train

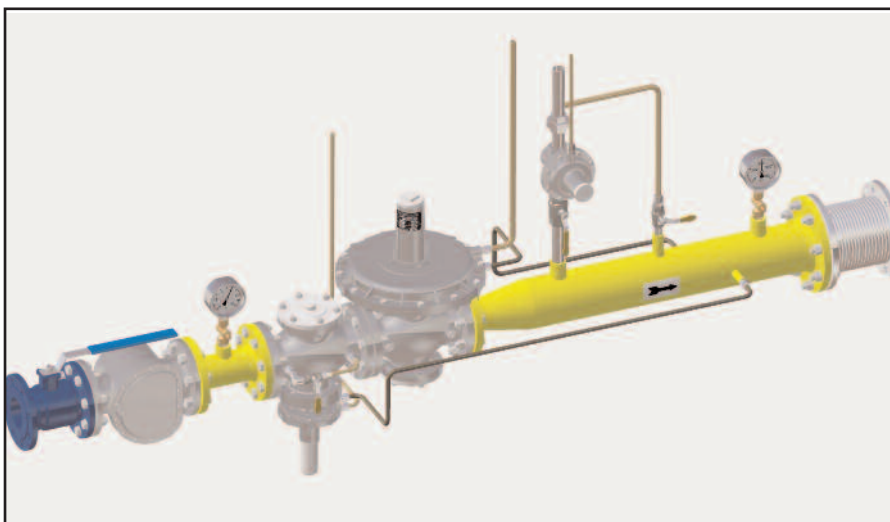

Install space -spring - X

R 101 DN 25-65 210mm
R 101 DN 100 410mm

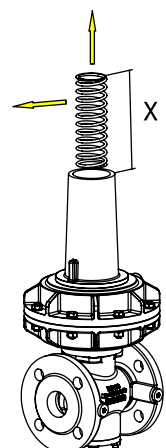

R 101

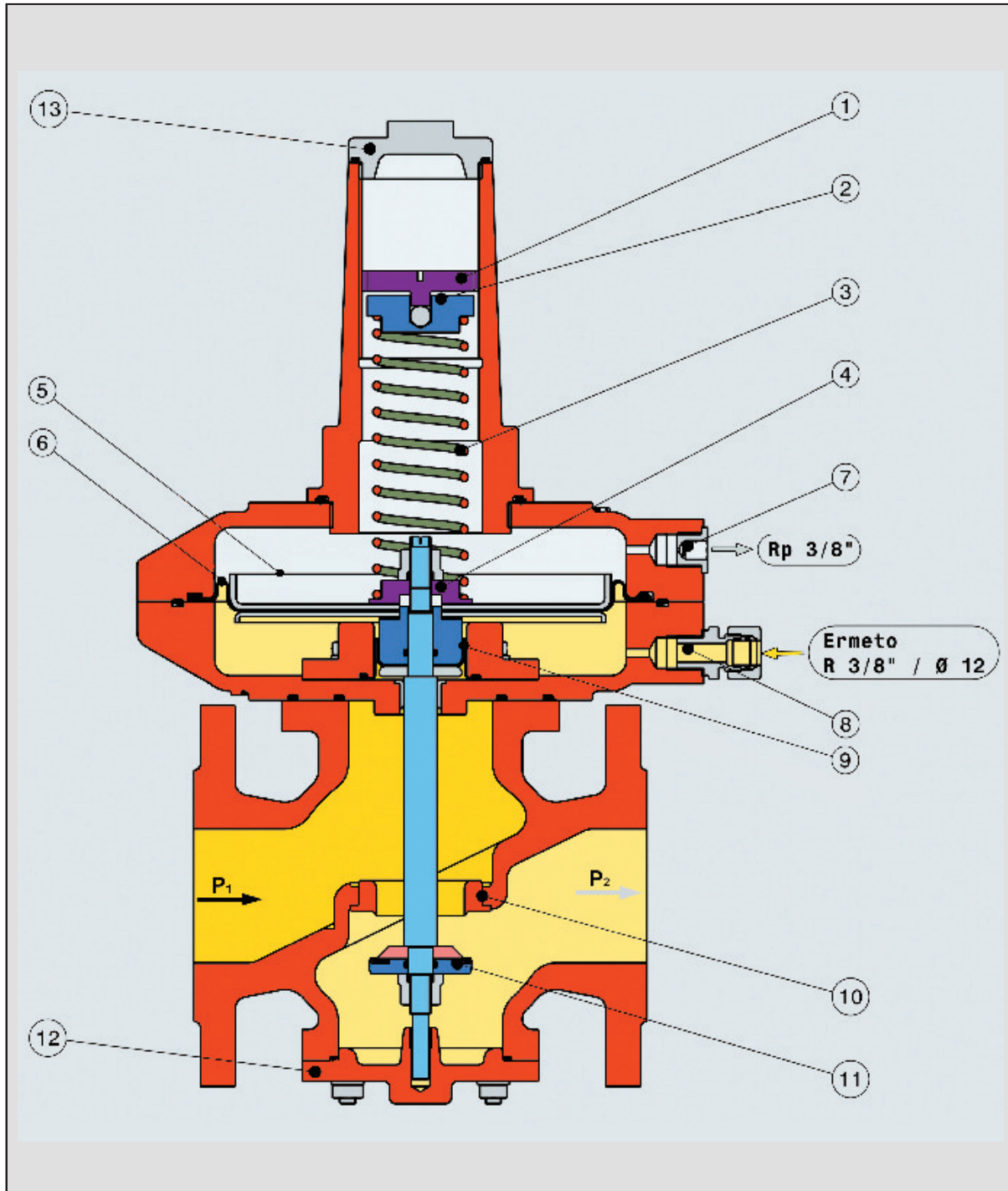

- 1 Pressure setting screw
- 2 Spring disc
- 3 Setting spring
- 4 Feet disc
- 5 Diaphragm disc
- 6 Main diaphragm

- 7 Vent connection
- 8 Impulse connection
- 9 Compensation diaphragm
- 10 Regulator valve seat
- 11 Valve disc
- 12 Cover plate

R 101

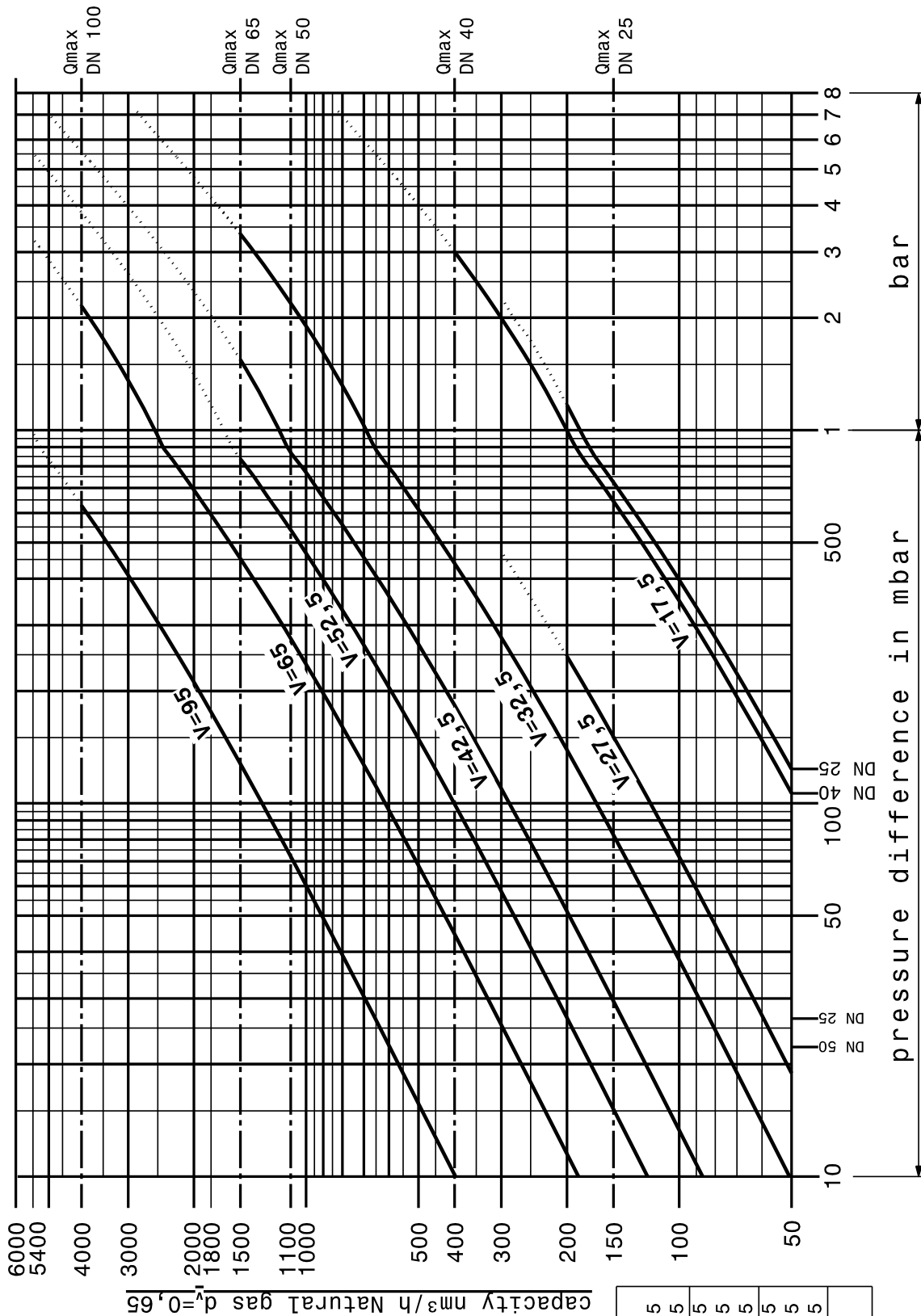

capacity m^3/h Natural gas $d_v=0,65$

R 101	
DN 025 - 17,5	27,5
DN 040 - 17,5	27,5
DN 050 - 32,5	32,5
DN 065 - 42,5	52,5
DN 100 - 65	95

R 101 DN 25

Pe = Pu max. 8 bar
Pa = Pd 22-1.200mbar
Q max. 200 Nm³/h
 (300) Nm³/h*

KG-Values

V 17,5 186 Nm³/h
V 27,5 459 Nm³/h

Gas characteristics:

suitable for gas of the gas families 1, 2, 3 (DVGW-G260) and not aggressiv gas.

Ambient-/ Working temp. -20...+60°C

Fitting position any

Flow speed max. 30m/s
 (limit 60m/s)*

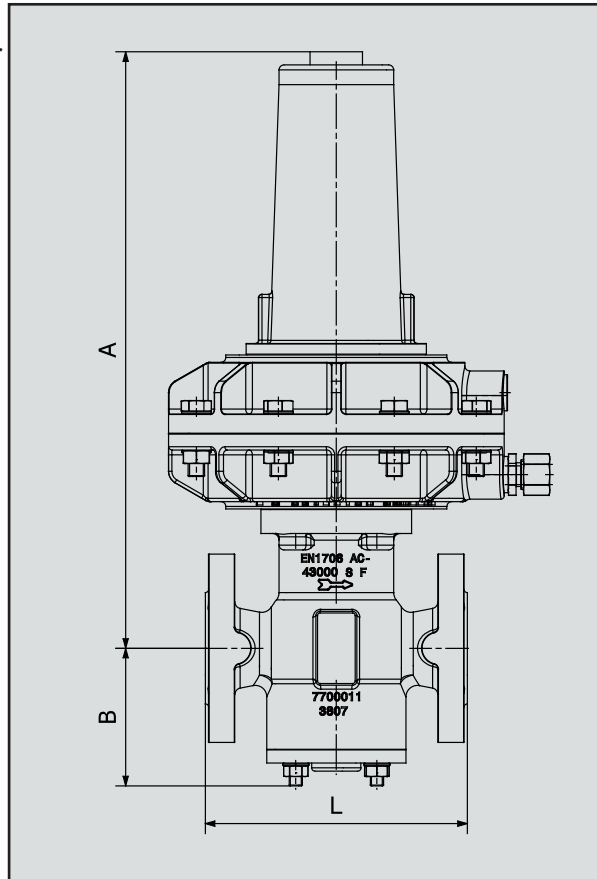

Special design:
high pressure shaft

* after consulting MEDENUS

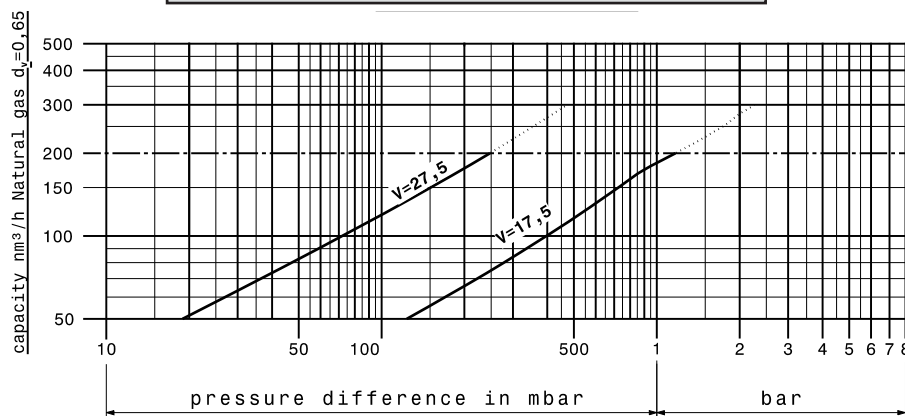

Pd < 200 mbar 200 - 800 mbar**	Pd < 750 mbar 750 - 1.200 mbar**	Pd < 1.200 mbar
10,5kg	8kg	6,5kg
PN16	PN16	PN16
A=346mm	A=364mm	A=356mm
B= 84mm	B= 84mm	B= 84mm
L=160mm	L=160mm	L=160mm
Ø 318	Ø 205	Ø 160
	** high pressure shaft	

R 101 DN 40

Pe = Pu max. 8 bar
Pa = Pd 22-1.200mbar
Q max. 500 Nm³/h
 (750) Nm³/h*

KG-Values

V 17,5 186 Nm³/h
V 27,5 459 Nm³/h
V 32,5 697 Nm³/h

Gas characteristics:

suitable for gas of the gas families 1, 2, 3 (DVGW-G260) and not aggressiv gas.

Ambient-/ Working temp. -20...+60°C

Fitting position any

Flow speed max. 30m/s
 (limit 60m/s)*

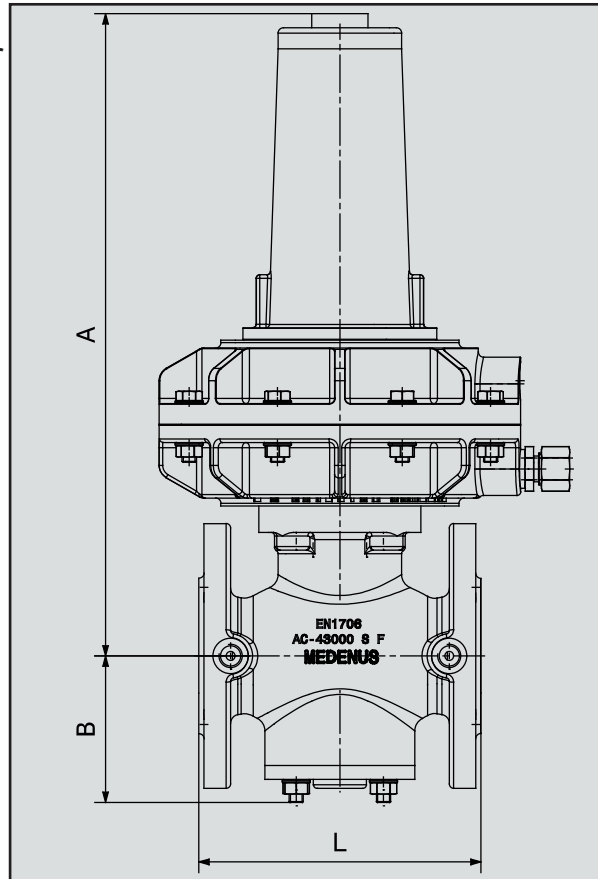

Special design:
 high pressure shaft

* after consulting MEDENUS

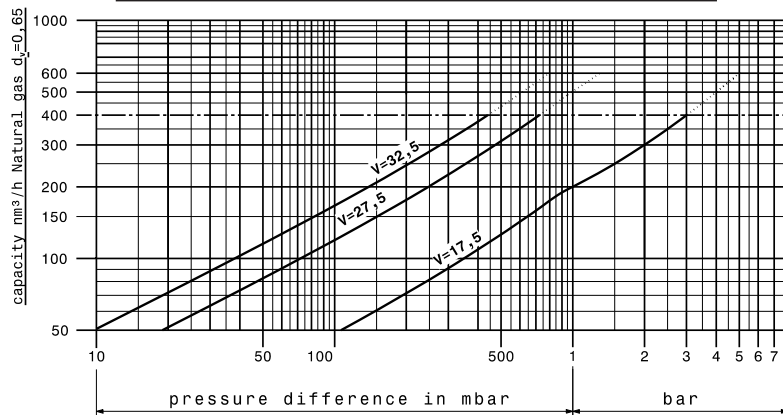

Pd < 200 mbar
200 - 800 mbar**
 11kg
 PN16
 A=346mm
 B= 84mm
 L=160mm

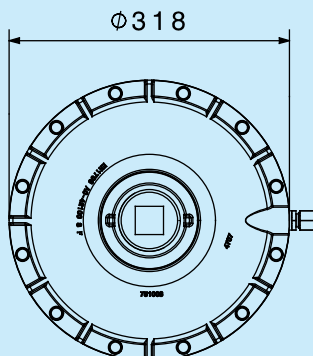

Pd < 750 mbar
750 - 1.200 mbar**
 9kg
 PN16
 A=364mm
 B= 84mm
 L=160mm

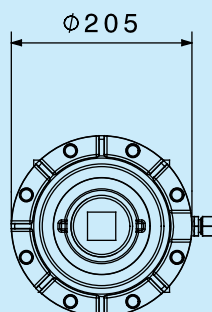

Pd < 1.200 mbar
 7,5kg
 PN16
 A=356mm
 B= 84mm
 L=160mm

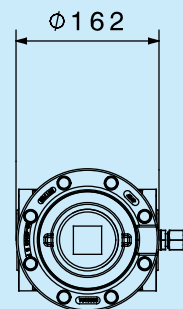

** high pressure shaft

R 101 DN 50

Pe = Pu max. 8 bar
Pa = Pd 22-1.200mbar
Q max. 1.100 Nm³/h
 (2.000) Nm³/h*

KG-Values

V 32,5 697 Nm³/h
V 42,5 1.191 Nm³/h
V 52,5 1.818 Nm³/h

Gas characteristics:

suitable for gas of the gas families 1, 2, 3 (DVGW-G260) and not aggressiv gas.

Ambient-/ Working temp. -20...+60°C

Fitting position any

Flow speed max. 30m/s
 (limit 60m/s)*

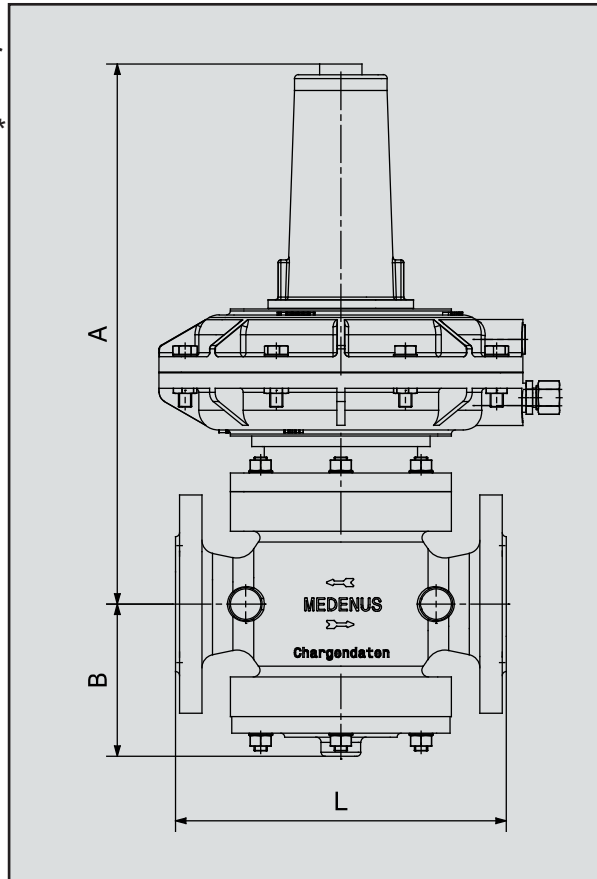

Special design:
 high pressure shaft

* after consulting MEDENUS

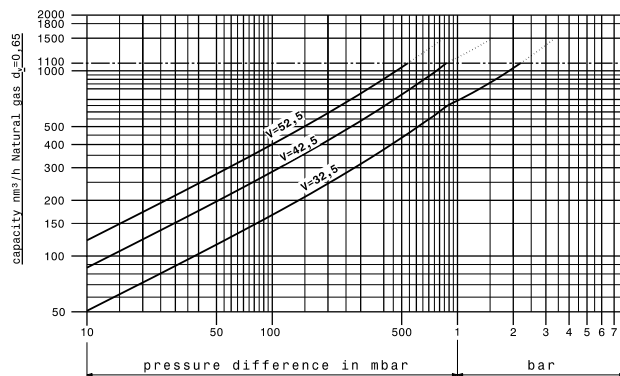

Pd < 130 mbar
130 - 450 mbar**
22kg
PN16
A=408mm
B=115mm
L=250mm

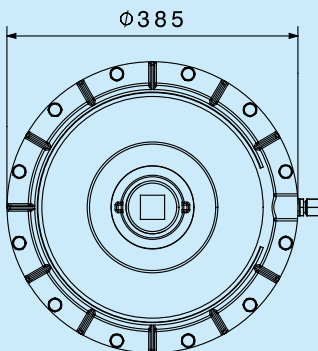

Pd < 400 mbar
400 - 1.100 mbar**
18kg
PN16
A=408mm
B=115mm
L=250mm

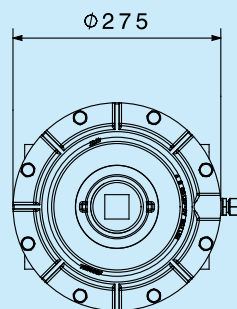

Pd < 750 mbar
750 - 1.200 mbar**
16kg
PN16
A=408mm
B=115mm
L=250mm

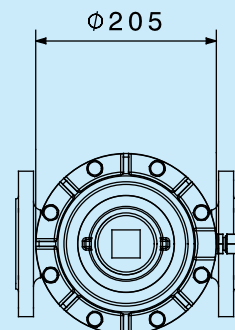

** high pressure shaft

R 101 DN 65

Pe = Pu max. 8 bar
Pa = Pd 22-1.200mbar
Q max. 1.500 Nm³/h
 (1.800) Nm³/h*

KG-Values

V 32,5 697 Nm³/h
V 42,5 1.191 Nm³/h
V 52,5 1.818 Nm³/h

Gas characteristics:

suitable for gas of the gas families 1, 2, 3 (DVGW-G260) and not aggressiv gas.

Ambient-/ Working temp. -20...+60°C

Fitting position any

Flow speed max. 30m/s
 (limit 60m/s)*

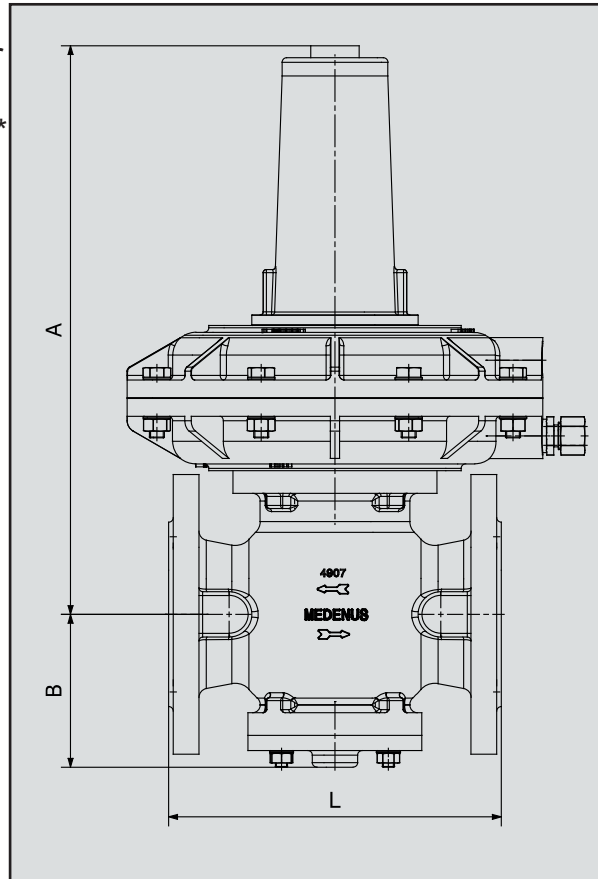

Special design:
 high pressure shaft

* after consulting MEDENUS

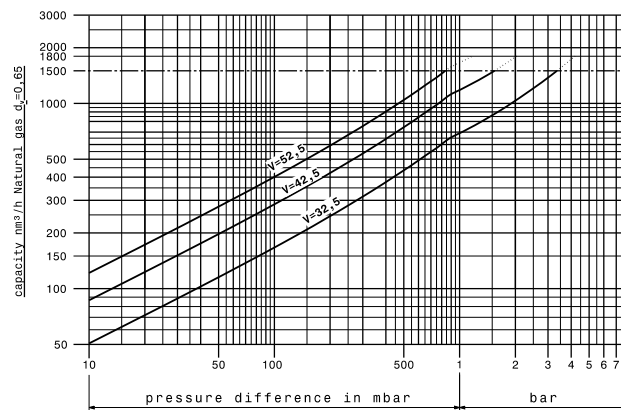

Pd < 130 mbar
130 - 450 mbar**
 22kg
 PN16
 A=376mm
 B=101mm
 L=220mm

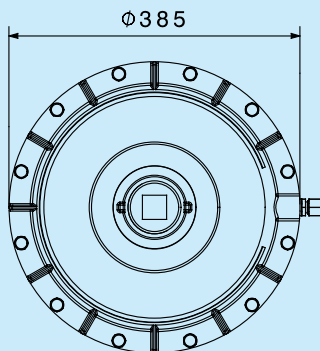

Pd < 400 mbar
400 - 1.100 mbar**
 18kg
 PN16
 A=376mm
 B=101mm
 L=220mm

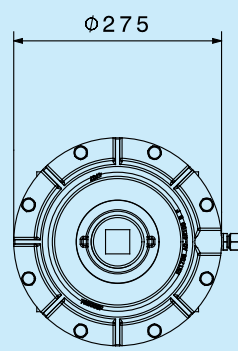

** high pressure shaft

Pd < 750 mbar
750 - 1.200 mbar**
 16kg
 PN16
 A=376mm
 B=101mm
 L=220mm

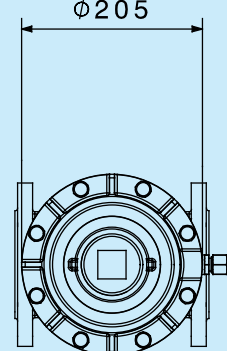

R 101 DN 100

Pe = Pu max. 8 bar
Pa = Pd 22-1.200mbar
Q max. 4.000 Nm³/h
 (5.400) Nm³/h*

KG-Values

V 65 2.566 Nm³/h
V 95 5.482 Nm³/h

Gas characteristics:

suitable for gas of the gas families 1, 2, 3 (DVGW-G260) and not aggressiv gas.

Ambient-/ Working temp. -20...+60°C

Fitting position any

Flow speed max. 30m/s
 (limit 60m/s)*

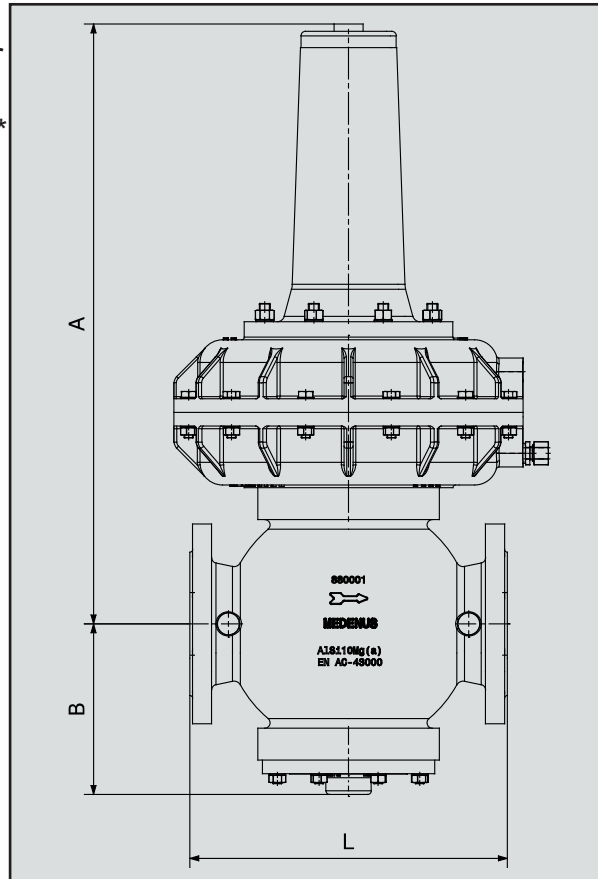

Special design:
high pressure shaft

* after consulting MEDENUS

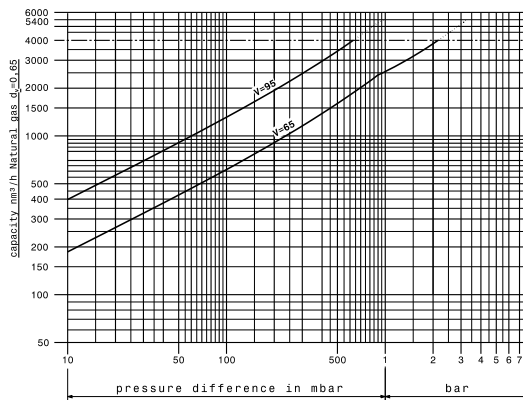

Pd < 150 mbar 150 - 450 mbar** 53kg PN16 A=661mm B=188mm L=350mm	Pd < 350 mbar 350 - 850 mbar** 43kg PN16 A=661mm B=188mm L=350mm	Pd < 850 mbar 850 - 1.200 mbar** 38kg PN16 A=661mm B=188mm L=350mm
<p>Ø485</p>	<p>Ø385</p>	<p>Ø275</p>

** high pressure shaft