

Diaphragm Valve, Metal

Construction

The GEMÜ 695 pneumatically operated 2/2-way diaphragm valve has a low maintenance membrane actuator which can be controlled by inert gaseous media. Normally Closed, Normally Open and Double Acting control functions are available.

Features

- Suitable for inert and corrosive* liquid and gaseous media
- Insensitive to particulate media
- Valve body and diaphragm available in various materials and designs
- Surface finishes down to 10 µinch, electropolished
- Versions according to ATEX on request
- Optical position indicator integrated as standard

Advantages

- Optional flow direction
- Installation for an optimized draining is possible
- Weight-saving design
- Optional accessories:
 - Stroke limiter
 - Manual override (GEMÜ 1002)
 - Pilot valve with manual override (GEMÜ 0322 - 0326)
 - Electrical position indicator

*see information on working medium on page 2



Sectional drawing

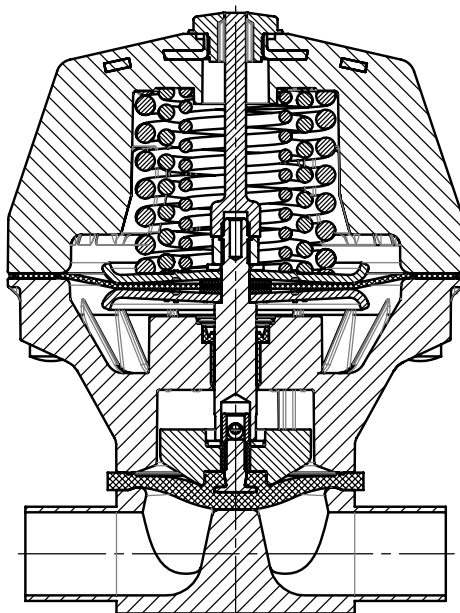

Technical data

Working medium

Corrosive, inert, gaseous and liquid media which have no negative impact on the physical and chemical properties of the body and diaphragm material.

The valve will seal in both flow directions up to full operating pressure. (All pressures are gauge pressures.)

Temperatures

Medium temperature	14 ... 176 °F
Ambient temperature	32 ... 140 °F

Control medium

Max. perm. temperature of control medium	104 °F
---	--------

Filling volume

Actuator size	Control function 1	Control function 2
FDM	11.59 cinch	-
FDN	11.59 cinch	9.76 cinch
HDM	31.73 cinch	-
HDN	31.73 cinch	24.41 cinch
JDM	64.69 cinch	-
JDN	64.69 cinch	40.89 cinch

C.f. 3 = for filling volume in open position see c.f. 1, for filling volume in closed position see c.f. 2

MG	DN	Actuator size	Operating pressure [psi]				Control pressure [bar]		
			Control function 1		Control function 2 + 3		Control function 1	Control function 2	Control function 3
			EPDM / FKM	PTFE	EPDM / FKM	PTFE			
25	15, 20, 25	FDM	0 - 90	0 - 90	-	-	55 - 87	-	-
		FDN	0 - 150	0 - 150	0 - 150	0 - 150	80 - 102	max. 80	max. 80
40	32, 40	HDM	0 - 90	0 - 90	-	-	55 - 87	-	-
		HDN	0 - 150	0 - 150	0 - 150	0 - 150	80 - 102	max. 80	max. 80
50	50, 65	JDM	0 - 90	0 - 90	-	-	55 - 87	-	-
		JDN	0 - 150	0 - 150	0 - 150	0 - 150	80 - 102	max. 73	max. 73

All pressures are gauge pressures. Operating pressure values were determined with static operating pressure applied on one side of a closed valve. Sealing at the valve seat and atmospheric sealing is ensured for the given values. Information on operating pressures applied on both sides and for high purity media on request.

Control functions 2 + 3 EPDM

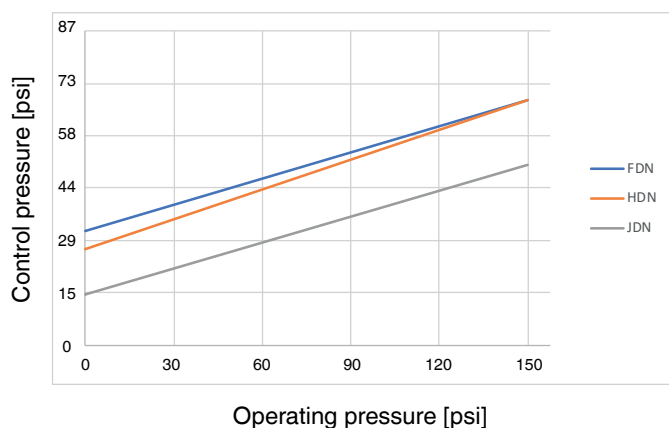

Control functions 2 + 3 PTFE

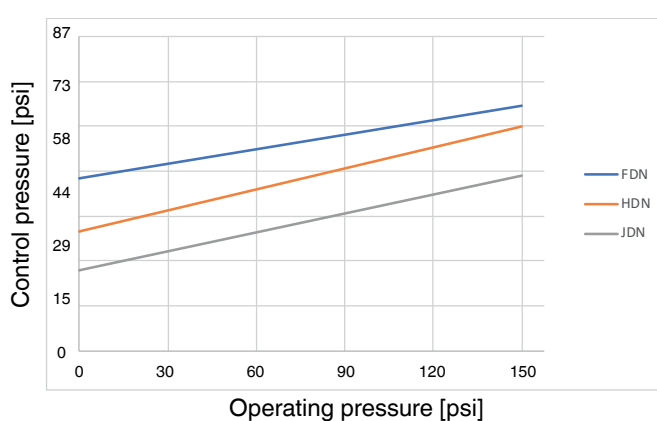

The values shown relate to control function 2 (with opening spring).
 For control function 3 (without opening spring) control pressure is approx. 1 bar lower.
 The control pressure depending on the prevailing operating pressure, as shown in the diagram, is intended as a guide for operating the system with low wear on the diaphragm.

Technical data

Cv values [gpm]

Pipe standard	DIN	EN 10357 series B (formerly DIN 11850 series 1)	EN 10357 series A (formerly DIN 11850 series 2) / DIN 11866 series A	DIN 11850 series 3	SMS 3008	ASME BPE / DIN 11866 series C	ISO 1127 / EN 10357 series C / DIN 11866 series B	DIN ISO 228	NPT	
Connection code	0	16	17	18	37	59	60	1	31	
MG	DN									
25	15	4.8	5.5	5.5	5.5	-	-	8.7	7.6	7.6
	20	7.4	8.2	8.2	8.2	-	5.1	15.4	11.7	11.7
	25	16.3	17.5	17.5	17.5	14.7	14.3	19	16.4	16.4
40	32	29.6	31.6	31.6	31.6	30.7	-	35.1	30.4	30.4
	40	34.3	36.2	36.2	36.2	35.3	34.5	38.4	38.6	38.6
50	50	54.4	56.6	56.6	56.6	60.5	59.2	64.6	70.2	70.2
	65	-	-	-	-	72.8	72.3	-	-	-

MG = diaphragm size

Cv values determined acc. to inlet pressure 75 psi, Δp 1 psi, stainless steel valve body (forged body) and soft elastomer diaphragm. The Cv values for other product configurations (e.g. other diaphragm or body materials) may differ. In general, all diaphragms are subject to the influences of pressure, temperature, the process and their tightening torques. Therefore the Cv values may exceed the tolerance limits of the standard.

The Kv value curve (Kv value dependent on valve stroke) can vary depending on the diaphragm material and duration of use.

Cv values [gpm]

MG	DN	GGG 40.3	GG 25	PFA / PP	Hartgummi
25	15	9.4	8.2	5.9	7.0
	20	13.5	16.4	10.5	12.9
	25	13.5	23.4	15.2	17.5
40	32	32.8	42.1	26.9	33.9
	40	32.8	46.8	30.4	37.4
50	50	70.2	93.6	55.0	74.9

MG = Membrangröße

Cv values determined acc. to inlet pressure 75 psi, Δp 1 psi, with connection flange EN 1092 length EN 558 series 1 (or threaded socket DIN ISO 228 for body material GGG40.3) and soft elastomer diaphragm.

The Cv values for other product configurations (e.g. other diaphragm or body materials) may differ. In general, all diaphragms are subject to the influences of pressure, temperature, the process and their tightening torques. Therefore the Cv values may exceed the tolerance limits of the standard.

Die Kv-Wert-Kurve (Kv-Wert in Abhängigkeit vom Ventilhub) kann je nach Membranwerkstoff und Einsatzdauer variieren.

Order data

Nominal size		Code
DN 15	NPS 1/2"	15
DN 20	NPS 3/4"	20
DN 25	NPS 1"	25
DN 32	NPS 1 1/4"	32
DN 40	NPS 1 1/2"	40
DN 50	NPS 2"	50
DN 65	NPS 2 1/2"	65

Body configuration	Code
2/2-way body	D

Connection	Code
Butt weld spigots	
Spigots DIN	0
Spigots EN 10357 series B (formerly DIN 11850 series 1)	16
Spigot EN 10357 series A (formerly DIN 11850 series 2) / DIN 11866 series A	17
Spigots DIN 11850 series 3	18
Spigots JIS-G 3447	35
Spigots JIS-G 3459	36
Spigots SMS 3008	37
Spigots BS 4825 Part 1	55
Spigot ASME BPE / DIN 11866 series C	59
Spigot ISO 1127 / EN 10357 series C / DIN 11866 series B	60
Spigots ANSI/ASME B36.19M Schedule 10s	63
Spigots ANSI/ASME B36.19M Schedule 15s	64
Spigots ANSI/ASME B36.19M Schedule 40s	65
Threaded connections	
Threaded sockets DIN ISO 228	1
Threaded spigots DIN 11851	6
Cone spigot and union nut DIN 11851	6K
Aseptic unions on request	

Flanges	
Flanges EN 1092 / PN16 / form B, length EN 558, series 1, ISO 5752, basic series 1	8
Flanges ANSI Class 150 RF, length MSS SP-88	38
Flanges ANSI Class 125/150 RF, length EN 558, series 1, ISO 5752, basic series 1	39

Clamp connections	
Clamps ASME BPE for pipe ASME BPE, length ASME BPE	80
Clamps DIN 32676 series B for pipe EN ISO 1127, length EN 558, series 7	82
Clamps ASME BPE for pipe ASME BPE, length EN 558, series 7	88
Clamps DIN 32676 series A for pipe DIN 11850, length EN 558, series 7	8A
Clamps SMS 3017 for pipe SMS 3008, length EN 558, series 7	8E
Clamps DIN 32676 series C, length FTF ASME BPE	8P
Clamps DIN 32676 series C, length FTF EN 558 series 7	8T
Aseptic clamps on request	

For overview of available valve bodies see page 15/16

Valve body material	Code
EN-GJL-250, (GG 25) (Cast iron)	8
EN-GJS-400-18-LT (S.G. Iron 40.3), PFA lined	17
EN-GJS-400-18-LT (S.G. Iron 40.3), PP lined	18
1.4435, investment casting	C3
1.4408, investment casting	37
1.4408, PFA lined	39
1.4435 (316L), forged body	40
1.4435 (BN2), forged body $\Delta Fe < 0.5\%$	42
EN-GJS-400-18-LT (S.G. Iron 40.3), hard rubber lined	83
EN-GJS-400-18-LT (GGG 40.3)	90
1.4539, forged body	F4

Diaphragm material	Code
NBR	2
FKM	4
EPDM	13
EPDM	17
EPDM	19
EPDM	29
EPDM	36
PTFE/EPDM, one-piece	54
PTFE/EPDM, two-piece	5M
PTFE/FKM, two-piece	5T
PTFE/PVDF/EPDM, three-piece	71**
** Code 71 only available for bodies with PFA lining (code 17 and code 39)	
Material complies with FDA requirements, except codes 2, 4 and 29	

Control function	Code
Normally closed (NC)	1
Normally open (NO)	2
Double acting (DA)	3

Actuator size	Code
Diaphragm size 25	FDM
Diaphragm size 25	FDN
Diaphragm size 40	HDM
Diaphragm size 40	HDN
Diaphragm size 50	JDM
Diaphragm size 50	JDN

Order data

Internal surface finishes for forged and block material bodies ¹

Readings for Process Contact Surfaces	Mechanically polished ²		Electropolished	
	Hygienic class DIN 11866	Code	Hygienic class DIN 11866	Code
Ra ≤ 31.5 μinch	H3	1502	HE3	1503
Ra ≤ 23.62 μinch	-	1507	-	1508
Ra ≤ 15.75 μinch	H4	1536	HE4	1537
Ra ≤ 9.84 μinch ³	H5	1527	HE5	1516

Readings for Process Contact Surfaces acc. to ASME BPE 2016 ⁴	Mechanically polished ²		Electropolished	
	ASME BPE Surface Designation	Code	ASME BPE Surface Designation	Code
Ra Max. = 30 μinch	SF3	SF3	-	-
Ra Max. = 25 μinch	SF2	SF2	SF6	SF6
Ra Max. = 20 μinch	SF1	SF1	SF5	SF5
Ra Max. = 15 μinch	-	-	SF4	SF4

Internal surface finishes for investment cast bodies

Readings for Process Contact Surfaces	Mechanically polished ²	
	Hygienic class DIN 11866	Code
Ra ≤ 248.03 μinch	-	1500
Ra ≤ 31.5 μinch	H3	1502
Ra ≤ 23.62 μinch ⁵	-	1507

¹ Surface finishes of customized valve bodies may be limited in special cases.

² Or any other finishing method that meets the Ra value (acc. to ASME BPE).

³ The smallest possible Ra finish for 1/4" (DN 8) BS 4825 Part 1 and ASME BPE is 15 μinch.

⁴ When using these surfaces, the bodies are marked according to the specifications of ASME BPE.

The surfaces are only available for valve bodies which are made of materials (e.g. GEMÜ material codes 40, 41, F4, 44) and use connections (e.g. GEMÜ connection codes 59, 80, 88) according to ASME BPE.

⁵ Not possible for GEMÜ connection code 59, DN 8 and GEMÜ connection code 0, DN 4.

Ra acc. to DIN EN ISO 4288 and ASME B46.1

Order example	695	25	D	60	C3	17	1	FDN	1500
Type	695								
Nominal size		25							
Body configuration (code)			D						
Connection (code)				60					
Valve body material (code)					C3				
Diaphragm material (code)						17			
Control function (code)							1		
Actuator size (code)								FDN	
Surface finish (code)									1500

Actuator dimensions [inch]

Actuator dimensions - control function 1

MG	Actuator size	ø B	A	A1	G	Weight [lb]
25	FDM, FDN	5.12	5.75	1.1	G 1/4	3.5
40	HDM, HDN	6.73	7.76	2.05	G 1/4	7.7
50	JDM, JDN	8.31	9.65	3.54	G 1/4	12.6

Control function 1 -
Actuator size FDM, FDN, HDM, HDN, JDM, JDN

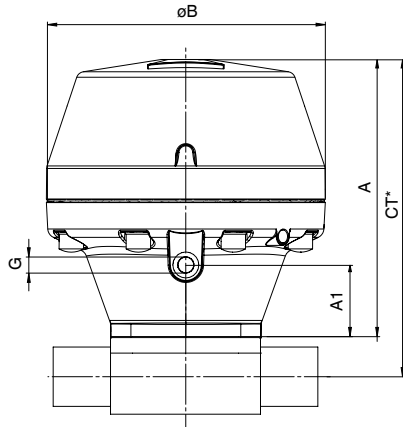

Actuator dimensions - control function 2 + 3

MG	Actuator size	ø B	A	A1	A2	G	Weight [lb]
25	FDM, FDN	5.12	4.84	1.1	1.85	G 1/4	2.2
40	HDM, HDN	6.73	6.38	2.05	2.17	G 1/4	4.9
50	JDM, JDN	8.31	8.11	3.54	1.89	G 1/4	8.4

Control function 2 + 3 -
Actuator size FDM, FDN, HDM, HDN, JDM, JDN

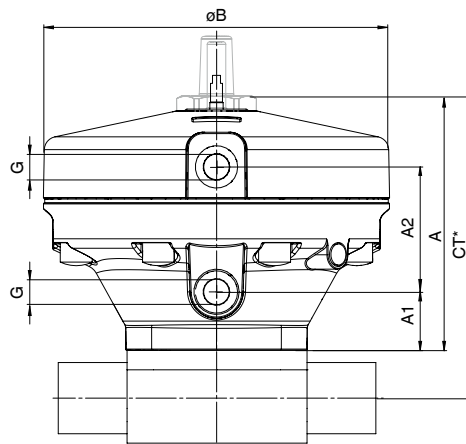

* CT = A + H1 (see body dimensions)

Body dimensions [inch]

Butt weld spigots, connection code 0, 16, 17, 18 Valve body material: Investment casting (code C3), forged body (code 40, F4)

Pipe standard							DIN		EN 10357 series B (formerly DIN 11850 series 1)		EN 10357 series A (formerly DIN 11850 series 2) / DIN 11866 series A		DIN 11850 Series 3		Weight [lb]
Connection code							0		16		17		18		
MG	DN	NPS	L	c	H1*	H1**	ød	s	ød	s	ød	s	ød	s	
25	15	1/2"	4.72	0.98	0.51	0.75	0.71	0.06	0.71	0.04	0.75	0.06	0.79	0.08	1.37
	20	3/4"	4.72	0.98	0.63	0.75	0.87	0.06	0.87	0.04	0.91	0.06	0.94	0.08	1.28
	25	1"	4.72	0.98	0.75	0.75	1.1	0.06	1.1	0.04	1.14	0.06	1.18	0.08	1.21
40	32	1 1/4"	6.02	0.98	0.94	1.02	1.34	0.06	1.34	0.04	1.38	0.06	1.42	0.08	3.2
	40	1 1/2"	6.02	0.98	1.02	1.02	1.57	0.06	1.57	0.04	1.61	0.06	1.65	0.08	2.91
50	50	2"	6.81	1.18	1.26	1.26	2.05	0.06	2.05	0.04	2.09	0.06	2.13	0.08	4.96

* only for investment cast design ** only for forged design MG = diaphragm size
For materials see overview on page 13

Butt weld spigots, connection code 60 Valve body material: Investment casting (code C3), forged body (code 40, F4)

Pipe standard							ISO 1127 / EN 10357 series C / DIN 11866 series B		Weight [lb]
Connection code							60		
MG	DN	NPS	L	c	H1*	H1**	ød	s	
25	15	1/2"	4.72	0.98	0.51	0.75	0.84	0.06	1.37
	20	3/4"	4.72	0.98	0.63	0.75	1.06	0.06	1.28
	25	1"	4.72	0.98	0.75	0.75	1.33	0.08	1.21
40	32	1 1/4"	6.02	0.98	0.94	1.02	1.67	0.08	3.2
	40	1 1/2"	6.02	0.98	1.02	1.02	1.9	0.08	2.91
50	50	2"	6.81	1.18	1.26	1.26	2.37	0.08	4.96

* only for investment cast design ** only for forged design MG = diaphragm size
For materials see overview on page 13

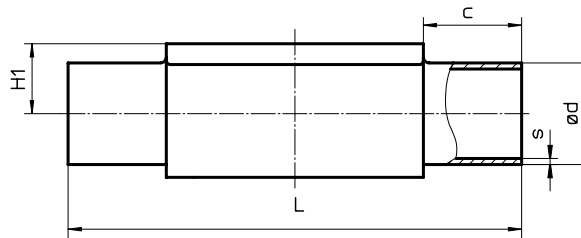

Body dimensions [inch]

Butt weld spigots, connection code 35, 36, 37 Valve body material: Investment casting (code C3), forged body (code 40, F4)

Pipe standard							JIS-G 3447		JIS-G 3459		SMS 3008		Weight [lb]
Connection code							35		36		37		
MG	DN	NPS	L	c	H1*	H1**	ød	s	ød	s	ød	s	
25	15	1/2"	4.72	0.98	-	0.75	-	-	0.85	0.08	-	-	1.37
	20	3/4"	4.72	0.98	-	0.75	-	-	1.07	0.08	-	-	1.28
	25	1"	4.72	0.98	0.75	0.75	1.00	0.05	1.34	0.11	0.98	0.05	1.21
40	32	1 1/4"	6.02	0.98	-	1.02	1.25	0.05	1.68	0.11	1.33	0.05	3.2
	40	1 1/2"	6.02	0.98	1.02	1.02	1.50	0.05	1.91	0.11	1.5	0.05	2.91
50	50	2"	6.81	1.18	1.26	1.26	2.00	0.06	2.38	0.11	2.01	0.05	4.96
	65	2 1/2"	6.81	1.18	-	1.34	2.50	0.08	-	-	2.50	0.06	4.85

* only for investment cast design ** only for forged design MG = diaphragm size
For materials see overview on page 13

Butt weld spigots, connection code 55, 59, 63, 64, 65 Valve body material: Investment casting (code C3), forged body (code 40, F4)

Pipe standard							BS 4825 Part 1		ASME BPE / DIN 11866 series C		ANSI/ASME B36.19M Schedule 10s		ANSI/ASME B36.19M Schedule 5s		ANSI/ASME B36.19M Schedule 40s		Weight [lb]
Connection code							55		59		63		64		65		
MG	DN	NPS	L	c	H1*	H1**	ød	s	ød	s	ød	s	ød	s	ød	s	
25	15	1/2"	4.72	0.98	-	0.75	-	-	-	-	0.84	0.08	0.84	0.06	0.84	0.11	1.37
	20	3/4"	4.72	0.98	0.63	0.75	0.75	0.05	0.75	0.06	1.05	0.08	1.05	0.06	1.05	0.11	1.28
	25	1"	4.72	0.98	0.75	0.75	-	-	1.00	0.06	1.31	0.11	1.31	0.06	1.31	0.13	1.21
40	32	1 1/4"	6.02	0.98	-	1.02	-	-	-	-	1.66	0.11	1.66	0.06	1.66	0.14	3.2
	40	1 1/2"	6.02	0.98	1.02	1.02	-	-	1.50	0.06	1.9	0.11	1.9	0.06	1.90	0.14	2.91
50	50	2"	6.81	1.18	1.26	1.26	-	-	2.00	0.06	2.37	0.11	2.37	0.06	2.37	0.15	4.96
	65	2 1/2"	6.81	1.18	-	1.34	-	-	2.50	0.06	-	-	-	-	-	-	4.63

* only for investment cast design ** only for forged design MG = diaphragm size
For materials see overview on page 13

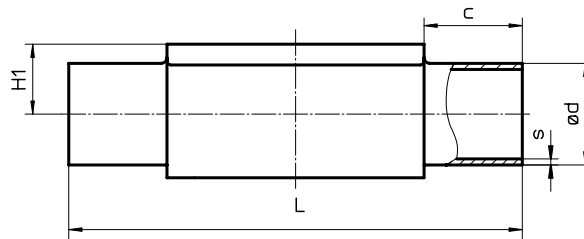

Body dimensions [inch]

Threaded sockets, connection code 1 Valve body material: investment casting (code 37), GGG40.3 (code 90)

MG	DN	R	Material code 37						Material code 90						Weight [lbs]
			H	H1	t	L	SW2	Anzahl der Schlüssel- flächen	H	H1	t	L	SW2	Anzahl der Schlüssel- flächen	
25	15	G 1/2	1.11	0.58	0.59	3.35	27	6	1.29	0.66	0.59	3.35	32	6	0.7
	20	G 3/4	1.31	0.68	0.63	3.35	32	6	1.65	0.85	0.64	3.35	41	6	0.7
	25	G 1	1.67	0.86	0.51	4.33	41	6	1.84	0.93	0.75	4.33	46	6	0.9
40	32	G 1 1/4	2.02	1.04	0.79	4.72	50	8	2.2	1.12	0.84	4.72	55	6	1.9
	40	G 1 1/2	2.22	1.13	0.71	5.51	55	8	2.6	1.32	0.84	5.51	65	6	2.1
50	50	G 2	2.81	1.43	1.02	6.5	70	8	2.99	1.52	1.01	6.5	75	6	3.4

MG = diaphragm size

For materials see overview on page 13

Threaded sockets, connection code 31 Valve body material: investment casting (code 37), GGG40.3 (code 90)

MG	DN	R	Material code 37						Material code 90						Weight [lbs]
			H	H1	t	L	SW2	Anzahl der Schlüssel- flächen	H	H1	t	L	SW2	Anzahl der Schlüssel- flächen	
25	15	NPT 1/2	1.11	0.58	0.55	3.35	27	6	1.29	0.66	0.54	3.35	32	6	0.7
	20	NPT 3/4	1.31	0.68	0.55	3.35	32	6	1.65	0.85	0.56	3.35	41	6	0.7
	25	NPT 1	1.67	0.86	0.67	4.33	41	6	1.84	0.93	0.66	4.33	46	6	0.9
40	32	NPT 1 1/4	2.02	1.04	0.67	4.72	50	8	2.2	1.12	0.68	4.72	55	6	1.9
	40	NPT 1 1/2	2.22	1.13	0.67	5.51	55	8	2.6	1.32	0.68	5.51	65	6	2.1
50	50	NPT 2	2.81	1.43	0.71	6.5	70	8	2.99	1.52	0.7	6.5	75	6	3.4

MG = diaphragm size

For materials see overview on page 13

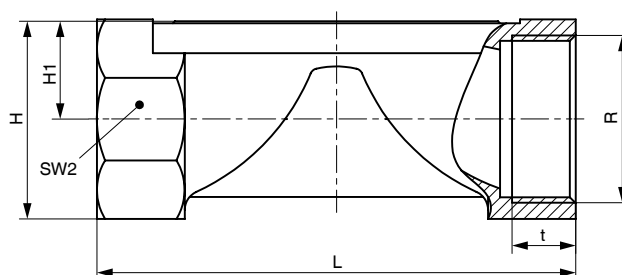

Body dimensions [inch]

Threaded connections, connection code 6 Valve body material: Forged body (code 40)

MG	DN	H1	ød1	Thread to DIN 405 R	L	Weight [kg]
25	15	0.75	0.63	RD 34 x 1/8	4.65	1.6
	20	0.75	0.79	RD 44 x 1/6	4.65	1.7
	25	0.75	1.02	RD 52 x 1/6	5.04	1.7
40	32	1.02	1.26	RD 58 x 1/6	5.79	3.7
	40	1.02	1.50	RD 65 x 1/6	6.30	3.6
50	50	1.26	1.97	RD 78 x 1/6	7.52	6.0

MG = diaphragm size

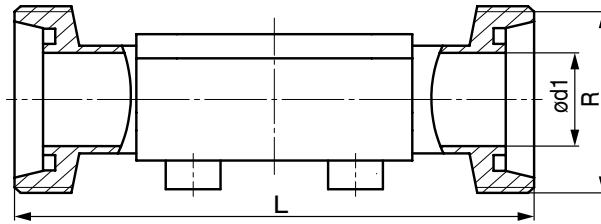

Threaded connections, connection code 6K Valve body material: Forged body (code 40)

MG	DN	H1	ød1	Thread to DIN 405 R	L	Weight [kg]
25	15	0.75	0.63	RD 34 x 1/8	4.57	1.6
	20	0.75	0.79	RD 44 x 1/6	4.49	1.7
	25	0.75	1.02	RD 52 x 1/6	5.00	1.7
40	32	1.02	1.26	RD 58 x 1/6	5.79	3.7
	40	1.02	1.50	RD 65 x 1/6	6.30	3.6
50	50	1.26	1.97	RD 78 x 1/6	7.52	6.0

MG = diaphragm size

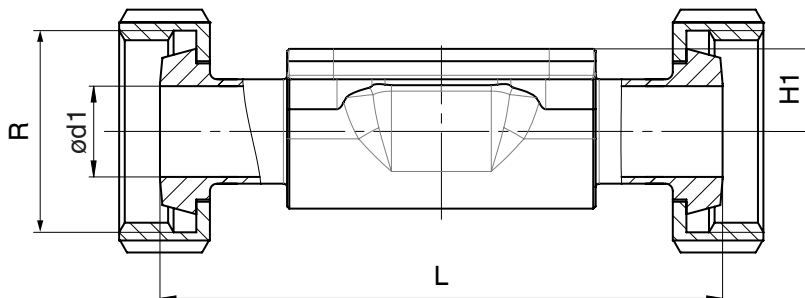

Body dimensions [inch]

Flanges - DIN EN 1092, connection code 8
 Valve body material GG 25 (code 8), GGG 40.3 (code 17, 18, 83), investment casting (code C3),
 forged body (code 40), investment casting PFA lined (code 39)

MG	DN	øD	øk	øL	Number of bolts	H1				FTF	Weight [lb]
						Material code 8	Material code 17, 18, 39, 83	Material code C3	Material code 40		
25	15	3.74	2.56	0.55	4	0.75	0.71	0.51	0.75	5.12*	4.08
	20	4.13	2.95	0.55	4	0.75	0.81	0.63	0.75	5.91	5.18
	25	4.53	3.35	0.55	4	0.75	0.91	0.75	0.75	6.3	6.28
40	32	5.51	3.94	0.75	4	1.1	1.13	0.94	1.02	7.09	10.8
	40	5.91	4.33	0.75	4	1.1	1.3	1.02	1.02	7.87	12.46
50	50	6.5	4.92	0.75	4	1.38	1.54	1.26	1.26	9.06	16.42

*Material code C3, 40 FTF = 5.91 (no DIN length)

MG = diaphragm size

For materials see overview on page 13

Flanges - ANSI Class 125/150 RF, connection code 38, 39
 Valve body material GG 25 (code 8), GGG 40.3 (code 17, 18, 83), investment casting (code C3),
 forged body (code 40), investment casting PFA lined (code 39)

MG	DN	øD	øk	øL	Number of bolts	H1				FTF		Weight [lb]	
						Connection code 38, 39				MSS Sp-88 Connection code 38			EN 558 Series 1 Connection code 39
						Material code 8	Material code 17, 18, 39, 83	Material code C3	Material code 40	Material code 17, 18, 39, 83			Material code 8, 17, 18, C3, 39, 40, 83
25	15	3.54	2.37	0.63	4	0.75	0.71	0.51	0.75	-	-	5.12	4.08
	20	4.09	2.75	0.63	4	0.75	0.81	0.63	0.75	5.75	5.76	5.91	5.18
	25	4.33	3.13	0.63	4	0.75	0.91	0.75	0.75	5.75	5.76	6.3	6.28
40	32	4.53	3.5	0.63	4	1.1	1.13	0.94	1.02	-	-	7.09	10.8
	40	4.92	3.87	0.63	4	1.1	1.3	1.02	1.02	6.89	6.75	7.87	12.46
50	50	5.91	4.75	0.75	4	1.38	1.54	1.26	1.26	7.87	7.77	9.06	16.42

MG = diaphragm size

For materials see overview on page 13

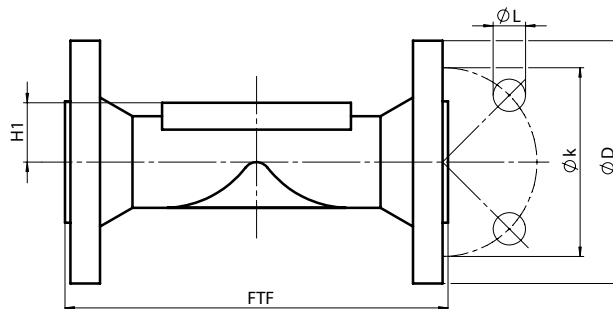

Body dimensions [inch]

Clamp connections, connection code 80, 82, 88, 8A, 8E Valve body material: Forged body (code 40, F4)

Pipe connection for clamp			ASME BPE						ISO 1127 / EN 10357 series C / DIN 11866 series B			EN 10357 series A (formerly DIN 11850 series 2) / DIN 11866 series A			SMS 3008			Weight [lb]	
Clamp connection			Code 80, 88 - ASME BPE Code 8P, 8T - DIN 32676 series C						DIN 32676 series B			DIN 32676 series A			ISO 2852 / SMS 3017				
Clamp connection code			80, 8P			88, 8T			82			8A			8E				
MG	DN	NPS	H1	ød1	ød3	L	ød1	ød3	L	ød1	ød3	L	ød1	ød3	L	ød1	ød3		L
25	15	1/2"	0.75	-	-	-	-	-	-	0.71	1.99	4.25	0.63	1.34	4.25	-	-	-	1.65
	20	3/4"	0.75	0.62	0.98	4	0.62	0.98	4.61	0.93	1.99	4.61	0.79	1.34	4.61	-	-	-	1.57
40	25	1"	0.75	0.87	1.99	4.5	0.87	1.99	5	1.17	1.99	5	1.02	1.99	5	0.89	1.99	5	1.39
	32	1 1/4"	1.02	-	-	-	-	-	-	1.51	2.52	5.75	1.26	1.99	5.75	1.23	1.99	5.75	3.57
50	40	1 1/2"	1.02	1.37	1.99	5.5	1.37	1.99	6.26	1.74	2.52	6.26	1.5	1.99	6.26	1.4	1.99	6.26	3.31
	50	2"	1.26	1.87	2.52	6.25	1.87	2.52	7.48	2.22	3.05	7.48	1.97	2.52	7.48	1.91	2.52	7.48	5.51
50	65	2 1/2"	1.34	2.37	3.05	7.63	2.37	3.05	8.5	-	-	-	-	-	-	2.37	3.05	8.5	5.07

MG = diaphragm size

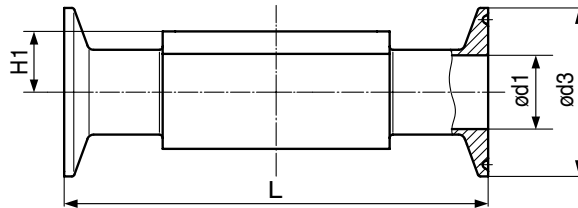

Overview of valve bodies for GEMÜ 695																		
		Spigots																
Connection code		0	16	17		18	35	36	37		55	59		60		63	64	65
Material code		40	40	C3	40	40	40	40	C3	40	40	C3	40	C3	40	40	40	40
MG	DN																	
25	15	X	X	X	X	X	-	X	-	-	-	-	-	X	X	X	X	X
	20	X	X	X	X	X	-	X	-	-	X	X	X	X	X	X	X	X
	25	X	X	X	X	X	X	X	X	X	-	X	X	X	X	X	X	X
40	32	X	X	X	X	X	X	X	X	-	X	-	-	-	X	X	X	X
	40	X	X	X	X	X	X	X	X	X	-	X	X	X	X	X	X	X
50	50	X	X	X	X	X	X	X	X	X	-	X	X	X	X	X	X	X
	65	-	-	-	-	-	-	X	-	-	X	-	-	X	-	-	-	-

Availability of material code 42, F4: same as code 40
MG = diaphragm size

All rights including copyright and industrial property rights are expressly reserved.

Overview of valve bodies for GEMÜ 695																													
		Threaded connections						Clamps				Flanges																	
Connection code		1		31		6, 6K	80, 8P	82	88, 8T	8A	8E	8						38				39							
Material code		37	90	37	90	40	40	40	40	40	8	17	18	C3	39	40	83	17	18	39	83	8	17	18	C3	39	40	83	
MG	DN																												
25	15	X	X	X	X	W	-	W	-	K	-	X	X	X	W	X	W	X	-	-	-	-	X	X	X	W	X	W	X
	20	X	X	X	X	W	K	K	K	K	-	X	X	X	W	X	W	X	X	X*	X	X	X	X	X	W	X	W	X
	25	X	X	X	X	W	K	K	K	K	K	X	X	X	W	X	W	X	X	X*	X	X	X	X	X	W	X	W	X
40	32	X	X	X	X	W	-	W	-	K	K	X	X	X	W	X	W	X	-	-	-	-	X	X	X	W	X	W	X
	40	X	X	X	X	W	K	W	K	K	K	X	X	X	W	X	W	X	X	X*	X	X	X	X	W	X	W	X	
50	50	X	X	X	X	W	K	W	K	K	K	X	X	X	W	X	W	X	X	X*	X	X	X	X	W	X	W	X	
	65	-	-	-	-	-	W	-	W	-	W	-	-	-	-	-	-	-	-	-	-	-	-	-	-	-	-	-	

* Connection code 38 / material code 18 on request
X = Standard
K = Connections completely machined (not welded)
W = Welded construction
Availability of material code 42, F4: same as code 40
MG = diaphragm size

Should there be any doubts or misunderstandings, the German version of this data sheet is the authoritative document!

For further metal diaphragm valves, accessories and other products, please see our Product Range catalogue and Price List.
Contact GEMÜ.

