

- **Globe valves** ▪ **Globe valve** ▪ **200 AE/BE/AJ/BJ** ▪ **PN 10-160** ▪ **DN 10-50**
- **Globe valves** ▪ **Lift check valve** ▪ **240 MT** ▪ **PN 10-160** ▪ **DN 10-50**

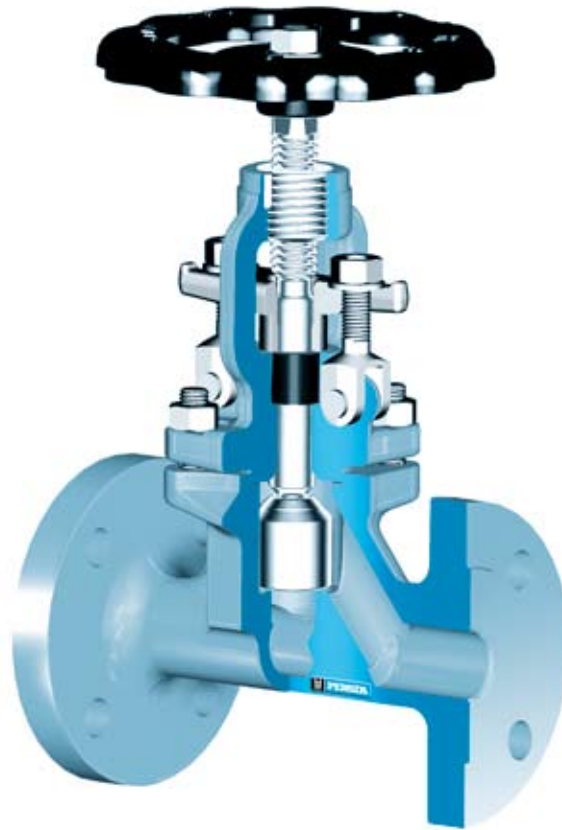

### Range of application

Admissible operating pressure [bar] at design temperature [°C] <sup>1)</sup>

Material	PN	Admissible operating pressure [bar] at design temperature [°C] <sup>1)</sup>																	
		-200	-60	-10	20	120	150	200	250	300	350	400	450	500	510	520	530	540	550
<b>1.0460</b>	<b>10-40</b>			40	40	40	37	35	32	28	24	21	10						
	<b>63</b>	63	63	63	58	50	45	40	36	32	24								
	<b>100</b>	100	100	100	90	80	70	60	56	50	38								
	<b>160</b>	160	160	160	145	130	112	96	90	80	60								
<b>1.5415</b> <sup>5)</sup>	<b>10-40</b>			40	40	40	40	40	35	31	30	28	18	14	11	9			
	<b>63</b>	63	63	63	63	63	63	56	50	47	45	29	22	16	14				
	<b>100</b>	100	100	100	100	100	100	87	78	74	70	45	34	27	22				
	<b>160</b>	160	160	160	160	160	160	139	125	118	112	72	55	43	35				
<b>1.7335</b>	<b>10-40</b>			40	40	40	40	40	40	38	36	34	29	24	19	15	12	9	
	<b>63</b>	63	63	63	63	63	63	63	61	58	56	47	40	32	25	20	15		
	<b>100</b>	100	100	100	100	100	100	100	95	91	87	74	62	49	38	31	24		
	<b>160</b>	160	160	160	160	160	160	160	153	146	139	118	100	79	62	46	35		
<b>1.4571</b>	<b>10-40</b> <sup>2)3)4)</sup>	40	40	40	40	40	40	40	38	36	34	32	32	32	31	31	31	31	
	<b>63</b> <sup>2)3)4)</sup>	63	63	63	63	63	59	56	53	50	48	47							
	<b>100</b> <sup>2)3)4)</sup>	100	100	100	100	100	92	88	83	79	76	73							
	<b>160</b> <sup>2)3)4)</sup>	160	160	160	160	160	150	142	135	127	123	119							
<b>1.0566</b>	<b>10-40</b> <sup>4)6)</sup>		40	40	40	37	35	32	28										
	<b>63</b> <sup>4)6)</sup>		63	63	63	58	50	45	40										
	<b>100</b> <sup>4)6)</sup>		100	100	100	92	80	70	60										
	<b>160</b> <sup>4)6)</sup>		160	160	160	147	130	112	96										

1) Operating temperature = design temperature minus temperature surcharge acc. to DIN regulations.  
2) Application at more than 400 °C operating temperature only admissible if no intercrystalline corrosion has to be expected.  
3) At operating temperature 400 °C the material of the screws is 1.4986.  
4) In case of screws A4-70 with > 8 x d screw-length the mechanical strength properties acc. to table 6 of DIN 267 Part 11 have been considered.  
5) Butt welding ends  
6) At temperature > 50 °C only applicable for short-time service.

- **Globe valves** ▪ **Globe valve** ▪ **200 AE/BE/AJ/BJ** ▪ **PN 10-160** ▪ **DN 10-50**
- **Globe valves** ▪ **Lift check valve** ▪ **240 MT** ▪ **PN 10-160** ▪ **DN 10-50**

#### Standard features

- Straight body
- Die-forged valve body and bonnet
- Shut-off disc, Fig. No. 200 AE
- Shut-off disc with yoke sleeve, standard features AJ
- Trottle disc with yoke sleeve, standard features BJ
- Trottle disc standard features BE
- Outside screw and yoke
- Position indicator if required
- Turning and rising stem (AE/BE)
- Non-turning, rising stem (AJ/BJ)

#### Pressure and temperature ratings

- Pressure rating BW-Ends up to 160 bar
- Pressure rating FL up to 160 bar
- Temperature rating up to 550 °C

#### Materials

- 1.0460
- 1.0566
- 1.5415 only with BW-Ends
- 1.7335
- 1.4571

Further materials on request.

#### Media

Depending on the material the valves are suitable for water, gas, oil and other non aggressive media

#### Fields of application

Chemical industries, power plants, ship building and other

#### Design Highlights

- Die-forged valve body and bonnet
- Seats are hardfaced or welded on
- Body-bonnet connection male and female
- Body and bonnet in two separate pieces with bolted connection

#### Benefits

- Free from porosity and shrink holes
- Extremely resistant to wear
- Sealing blow out proof
- To ease maintenance work, e.g. regrinding of the body seats

- **Globe valves** ▪ **Globe valve** ▪ **200 AE/BE/AJ/BJ** ▪ **PN 10-160** ▪ **DN 10-50**
- **Globe valves** ▪ **Lift check valve** ▪ **240 MT** ▪ **PN 10-160** ▪ **DN 10-50**

**Globe valve AE/BE**

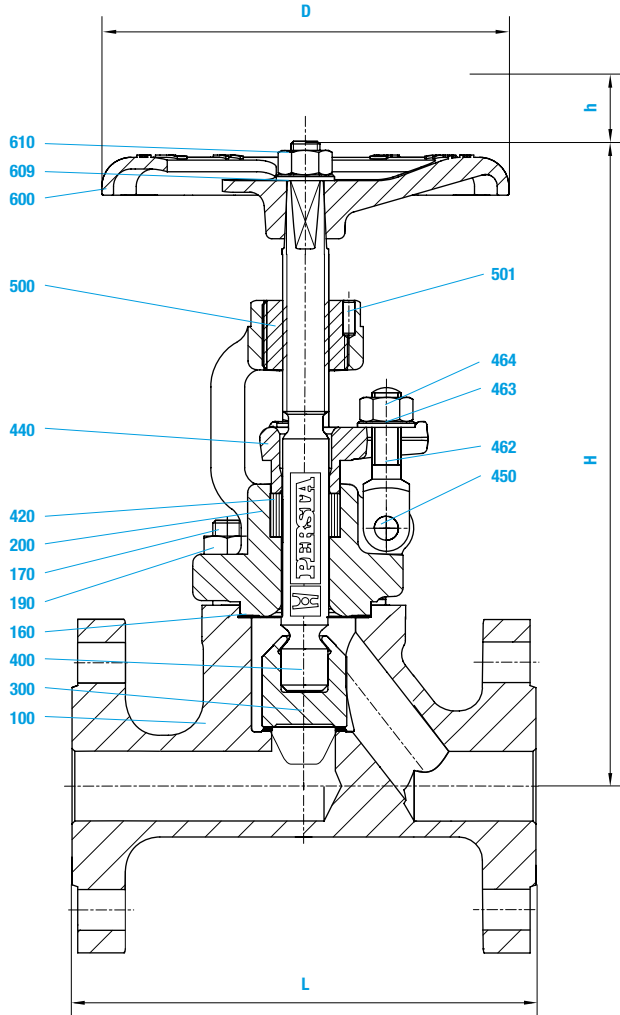

**Globe valve AJ/BJ**

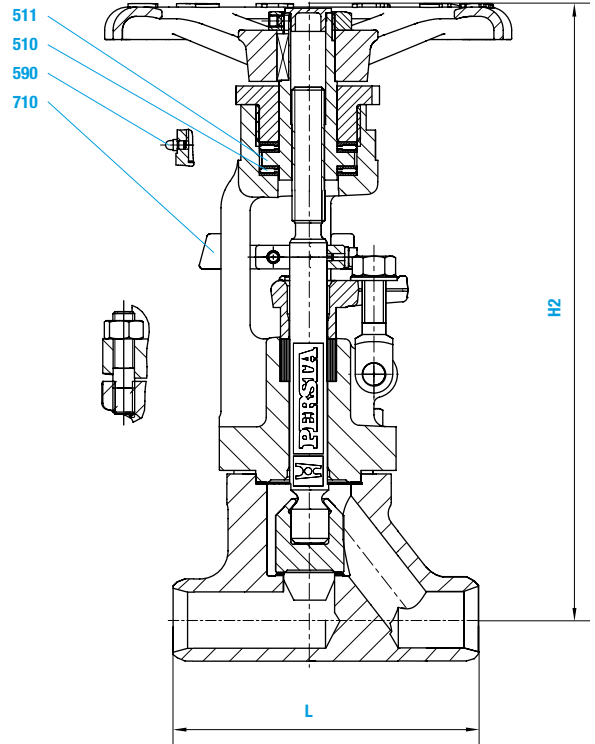

**Lift check valve**

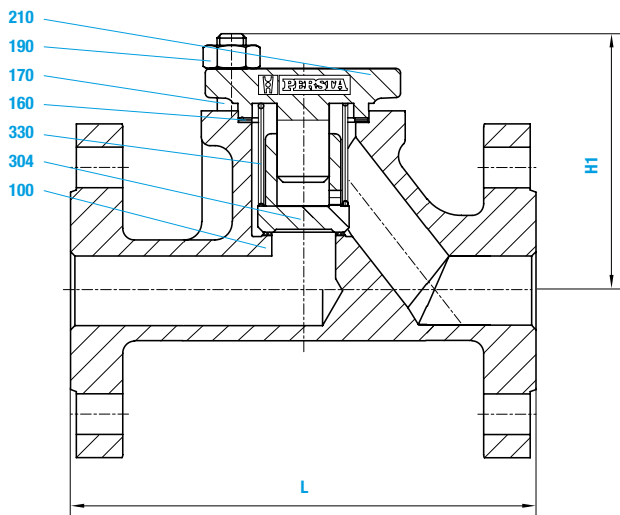

**BW-Version**

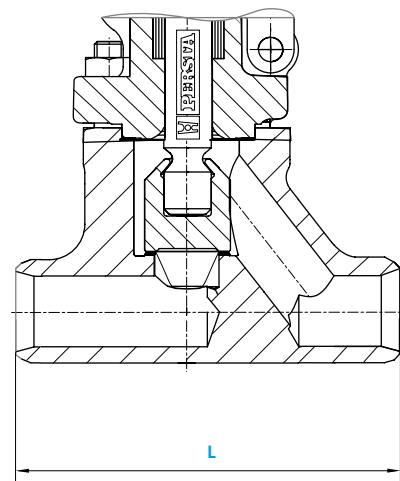

- **Globe valves** ▪ **Globe valve** ▪ **200 AE/BE/AJ/BJ** ▪ **PN 10-160** ▪ **DN 10-50**
- **Globe valves** ▪ **Lift check valve** ▪ **240 MT** ▪ **PN 10-160** ▪ **DN 10-50**

Materials							
Pos.	Component	1.0460 (21)	1.0566 (25)	BW-Version 1.5415 (42)	1.7335 (44)	1.4571 (82)	1.4571 (87)
100	Body	1.0460 <sup>4(8)</sup>	1.0566 <sup>4)</sup>	1.5415 <sup>5)</sup>	1.7335 <sup>5)</sup>	1.4571 <sup>7)</sup>	1.4571 <sup>7)</sup>
160	▶ Gasket	Graphite	Graphite	Graphite	Graphite	Teflon	Graphite
170	Stud <sup>1)</sup>	1.1181	A4-70	1.7709	1.7709	A4-70	A4-70
170	Stud <sup>2)</sup>	1.7709	A4-70	1.4923	1.4923	A4-70	A4-70
190	Hexagonal nut <sup>1)</sup>	1.1181	A4-70	1.7218	1.7218	A4-70	A4-70
190	Hexagonal nut <sup>2)</sup>	1.7218	A4-70	1.7218	1.7218	A4-70	A4-70
200	Bonnet	1.0460	1.0566	1.7335	1.7335	1.4571	1.4571
210	Bonnet	1.0460	1.0566	1.7335	1.7335	1.4571	1.4571
300	▶ Disc	1.4021 <sup>3)</sup>	1.0566 <sup>4)</sup>	1.7335 <sup>5)</sup>	1.7335 <sup>5)</sup>	1.4571 <sup>6)</sup>	1.4571 <sup>6)</sup>
304	▶ Disc	1.4021 <sup>3)</sup>	1.4571 <sup>6)</sup>	1.4571 <sup>5)</sup>	1.4571 <sup>5)</sup>	1.4571 <sup>6)</sup>	1.4571 <sup>6)</sup>
330	▶ Spring	1.4310	1.4310	1.4310	1.4310	1.4571	1.4571
400	▶ Stem	1.4021	1.4571	1.4021	1.4021	1.4571	1.4571
420	▶ Packing	Graphite	Graphite	Graphite	Graphite	Teflon	Graphite
440	Gland flange	1.0460	1.4571	1.0460	1.0460	1.4571	1.4571
450	Rivet	1.1181	A4-50	1.1181	1.1181	A4-50	A4-50
462	Gland bolt	1.1181	1.4571	1.1181	1.1181	1.4571	1.4571
463	Washer	St	A4-50	St	St	A4-50	A4-50
464	Hexagonal nut	1.1181	A4-70	1.1181	1.1181	A4-70	A4-70
500	▶ Stem nut	1.0718	1.0718	1.0718	1.0718	1.0718	1.0718
501	▶ Cylindrical pin	St	St	St	St	St	St
510	▶ Yoke sleeve	1.0718	1.0718	1.0718	1.0718	1.0718	1.0718
511	▶ Needle bearing	WLS	WLS	WLS	WLS	WLS	WLS
590	Grease nipple	5.8	5.8	5.8	5.8	5.8	5.8
600	Handwheel	5.3106	5.3106	5.3106	5.3106	5.3106	5.3106
609	Washer	St	St	St	St	A4-50	A4-50
610	Hexagonal nut	1.1181	1.1181	1.1181	1.1181	A4-70	A4-70
710	Anti-rotation device	5.3106	5.3106	5.3106	5.3106	5.3106	5.3106

▶ Spare parts  
Special materials on request; alterations reserved.

1) PN 10-40  
2) PN 63-160  
3) Seat hard faced  
4) Seat hard faced with Cr17  
5) Seat hard faced with Stellite  
6) ≥ PN 63 seat hard faced with Stellite  
7) ≥ PN 63 seat hard faced with hastelloy  
8) DN 50 PN 10-160 Flange Version with 1.0619 hard faced with Cr17

Dimensions/mm									
PN	DN	FL L	BW L	H	H1	H2	Stroke h	D	1.0619 H
<b>10-40</b>	<b>10</b>	130	130	215	85	275	12	140	
	<b>15</b>	130	130	215	85	275	12	140	
	<b>20</b>	150	130	220	90	275	12	140	
	<b>25</b>	160	130	220	90	275	12	140	
	<b>32</b>	180	160	245	115	305	15	180	
	<b>40</b>	200	180	250	130	305	15	180	
<b>63-160</b>	<b>50</b>	230	210	260	120	345	18	180	
	<b>10</b>	210	150	220	100	275	12	180	
	<b>15</b>	210	150	220	100	275	12	180	
	<b>20</b>	230	150	220	100	275	12	180	
	<b>25</b>	230	160	220	100	275	12	180	
	<b>32</b>	260	180	285	140	335	15	225	
<b>63-100</b>	<b>40</b>	260	210	285	140	335	15	225	
	<b>50</b>	300	250	285	150	345	18	150	260
<b>160</b>	<b>50</b>	300	250	285	150	345	18	225	260

The valves are also available in angle pattern up DN 100.

Weights/kg					
PN	DN	200 AE/BE		240 MT	
		FL	BW	FL	BW
<b>10-40</b>	<b>10</b>	4,5	3,8	3,2	2,4
	<b>15</b>	5,0	4,2	3,2	2,4
	<b>20</b>	5,7	3,8	3,9	2,4
	<b>25</b>	6,3	4,0	4,7	2,3
	<b>32</b>	10,0	7,3	7,9	5,5
	<b>40</b>	11,2	7,3	9,1	5,5
<b>63-160</b>	<b>50</b>	15,5	11,0	12,1	7,9
	<b>10</b>	8,7	5,9	6,0	4,0
	<b>15</b>	8,6	6,2	6,8	4,0
	<b>20</b>	10,4	5,5	9,0	4,0
	<b>25</b>	10,9	5,8	9,2	4,0
	<b>32</b>	19,0	13,2	15,6	9,0
<b>63-100</b>	<b>40</b>	21,0	12,8	16,8	9,0
	<b>50</b>	24,1	15,0	19,5	11,0
<b>160</b>	<b>50</b>	25,0	15,0	22,0	11,0

Kvs-values (m3/h)														
Line	DN 10	DN 15	DN 20	PN 10-40				DN 10	DN 15	DN 20	PN 63-160			
				DN 25	DN 32	DN 40	DN 50				DN 25	DN 32	DN 40	DN 50
<b>200 AE (BW)</b>	3,0	4,5	6,2	8,6	16,0	21,0	30,0	3,0	4,5	6,2	8,6	16,0	21,0	30,0
<b>200 AE (FL)</b>	1,8	3,0	5,3	8,6	13,0	21,0	37,2	1,8	4,5	5,3	8,6	13,0	21,0	37,2
<b>200 BE (BW)</b>	2,8	4,2	5,9	7,6	14,5	19,5	26,9	2,8	4,2	5,9	7,6	14,5	19,5	26,9
<b>200 BE (FL)</b>	1,5	2,8	4,9	7,6	11,2	19,5	34,5	2,8	4,2	5,9	7,6	14,5	19,5	34,5
<b>240 MT (BW)</b>	2,7	4,1	5,7	7,9	14,6	19,2	34,0	2,7	4,1	5,7	7,9	14,6	19,2	34,0
<b>240 MT (FL)</b>	1,7	2,7	5,7	7,9	11,9	19,2	25,8	1,7	2,7	5,7	7,9	11,9	19,2	25,8

- **Globe valves** ▪ **Globe valve** ▪ **200 AE/BE/AJ/BJ** ▪ **PN 10-160** ▪ **DN 65-200**
- **Globe valves** ▪ **Lift check valve** ▪ **240 MT** ▪ **PN 10-160** ▪ **DN 65-200**



### Range of application

Admissible operating pressure [bar] at design temperature [°C] <sup>1)</sup>

Material	PN	Admissible operating pressure [bar] at design temperature [°C] <sup>1)</sup>																					
		-200	-50	-10	20	100	120	150	200	250	300	350	400	425	450	475	500	510	520	530	540	550	
<b>1.0619</b>	<b>10-16</b>			16	16	16	16	15	14	13	11	10	8										
	<b>25</b>			25	25	25	25	23	22	20	17	16	13										
	<b>40</b>			40	40	40	40	37	35	32	28	24	21										
	<b>63</b>			63	63	63	63	53	50	45	40	36	32										
	<b>100</b>			100	100	100	100	83	80	70	60	56	50										
	<b>160</b> <sup>3)</sup>			160	160	160	160	135	130	112	96	90	80										
<b>1.5419</b>	<b>10</b>			10	10	9	9	9	8	7	7	7	6	6	6	6	3	3	2	2			
	<b>25</b>			25	25	23	23	22	20	19	17	16	16	16	15	15	9	7	6	4			
	<b>40</b>			40	40	36	36	35	31	29	27	26	25	24	24	23	14	11	9	7			
	<b>63</b>			63	63	59	59	58	51	48	45	42	41	40	39	38	22	18	14	12			
	<b>100</b>			100	100	92	92	90	80	74	69	65	63	62	61	59	35	28	22	18			
	<b>160</b> <sup>3)</sup>			160	160	148	148	143	128	119	111	104	101	100	98	94	55	44	35	29			
<b>1.7221</b>	<b>10-16</b> <sup>2)</sup>			16	16	16	16	15,1	15	14	13	11											
	<b>25</b> <sup>2)</sup>			25	25	25	25	23,6	23	22	20	17											
	<b>40</b> <sup>2)</sup>			40	40	40	40	37,7	37	35	32	28											
	<b>63</b> <sup>2)</sup>			63	63	63	55	54	53	50	45	40											
	<b>100</b> <sup>2)</sup>			100	100	100	87	84	83	80	70	60											
	<b>160</b> <sup>2)</sup>			160	160	160	140	136	135	130	112	96											
<b>1.7357</b>	<b>10-16</b>			16	16	16	16	15	14	13	11	10	8										
	<b>25</b>			25	25	25	25	25	25	25	25	25	24	23	22	21	20	18	15	12	9		
	<b>40</b>			40	40	40	40	40	40	40	40	40	38	36	35	34	33	29	24	19	15		
	<b>63</b>			63	63	63	63	63	63	63	63	61	58	57	56	51	47	40	32	25			
	<b>100</b> <sup>4)</sup>			100	100	100	100	100	100	100	100	95	91	89	87	80	74	62	49	38			
<b>1.4308</b>	<b>10-16</b>	16	16	16	16	13	12,6	12	11	8	8												
	<b>25</b>	25	25	25	25	21	19,8	18	17	13	12												
	<b>40</b>	40	40	40	40	34	32,4	30	24	21	20												
<b>1.4581</b>	<b>10-16</b>			16	16	15	14,6	14	13	13	12	12	11	10	8	7,5	7	7	7	7	7	6,5	
	<b>25</b>			25	25	24	23,2	22	21	20	19	18	17	16	13	12,5	12	11	11	11	11	11	
	<b>40</b>			40	40	38	36,8	35	33	32	30	28	26	24	21	20	19	19	19	19	18	18	

1) Operating temperature = design temperature minus temperature surcharge acc. to DIN regulations.  
 2) At temperature > 50 °C only applicable for short-time service.  
 3) PN 160 is only valid for DN 65-100.  
 4) Only for globe valves DN 65-80; for lift check valves DN 65-125.

Permissible differential pressure (pressure inlet below the disc) acc. to EN 13709.

- **Globe valves** ▪ **Globe valve** ▪ **200 AE/BE/AJ/BJ** ▪ **PN 10-160** ▪ **DN 65-200**
- **Globe valves** ▪ **Lift check valve** ▪ **240 MT** ▪ **PN 10-160** ▪ **DN 65-200**

#### Standard features

- Straight bonnet
- Cast steel body and bonnet
- Shut-off disc, Fig. No. AE
- Shut-off disc with yoke sleeve standard features AJ
- Throttle disc with yoke sleeve standard features BJ
- Throttle disc, Fig. No. 200 BE
- Outside screw and yoke
- Position indicator if required
- Turning and rising stem (AE/BE)
- Non-turning, rising stem (AJ/BJ)

#### Pressure and temperature ratings

- Pressure rating BW-Ends up to 160 bar
- Pressure rating FL up to 160 bar
- Temperature rating up to 550 °C

#### Materials

- 1.0619
- 1.5419
- 1.7221
- 1.7357
- 1.4581
- 1.4308

Further materials on request.

#### Media

Depending on the material the valves are suitable for water, gas, oil and other non aggressive media

#### Fields of application

Chemical industries, power plant, ship building and other

#### Design Highlights

- Seats are welded on
- Body-bonnet connection male and female
- Body and bonnet in two pieces with bolted connection

#### Benefits

- Extremely resistant to wear
- Sealing blow out proof
- To ease maintenance work, e.g. regrinding

- **Globe valves** ▪ **Globe valve** ▪ **200 AE/BE/AJ/BJ** ▪ **PN 10-160** ▪ **DN 65-200**
- **Globe valves** ▪ **Lift check valve** ▪ **240 MT** ▪ **PN 10-160** ▪ **DN 65-200**

**Globe valve AE/BE**

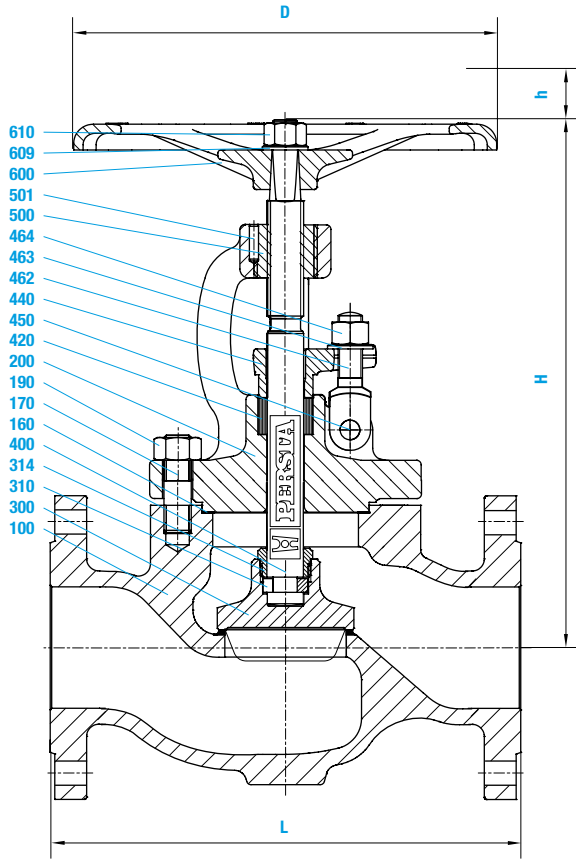

**Globe valve AJ/BJ**

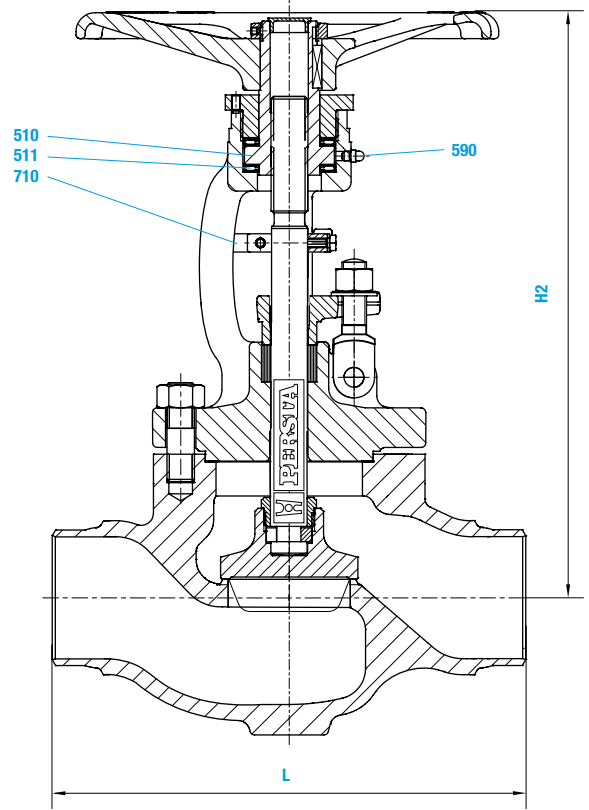

**Lift check valve**

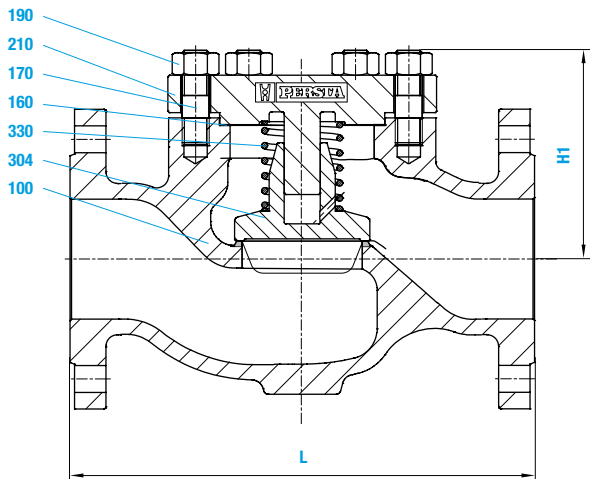

**BW-Version**

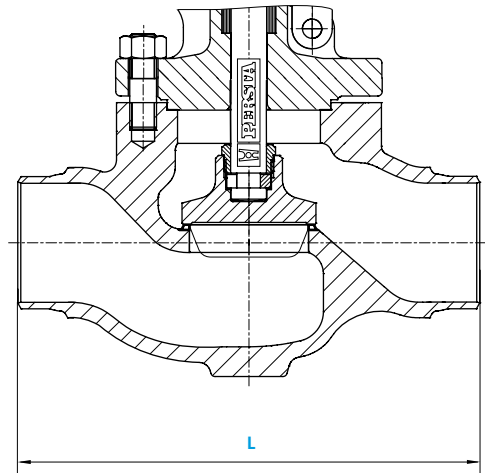

- **Globe valves** ▪ **Globe valve** ▪ **200 AE/BE/AJ/BJ** ▪ **PN 10-160** ▪ **DN 65-200**
- **Globe valves** ▪ **Lift check valve** ▪ **240 MT** ▪ **PN 10-160** ▪ **DN 65-200**

Materials							
Pos.	Component	1.0619 (11)	1.5419 (32)	1.7221 (31)	1.7357 (34)	1.4581 (72)	1.4308 (77)
100	Body	1.0619 <sup>4)</sup>	1.5419 <sup>5)</sup>	1.7221	1.7357 <sup>5)</sup>	1.4581 <sup>9)</sup>	1.4308 <sup>9)</sup>
160	▶ Gasket	Graphite	Graphite	Graphite	Graphite	Teflon	Graphite
170	Stud <sup>1)</sup>	1.1181	1.7709	A4-70	1.7709	A4-70	A4-70
170	Stud <sup>2)</sup>	1.7709	1.4923	A4-70	1.4923		
190	Hexagonal nut <sup>1)</sup>	1.1181	1.7218	A4-70	1.7218	A4-70	A4-70
190	Hexagonal nut <sup>2)</sup>	1.7218	1.7218	A4-70	1.7218		
200	Bonnet	1.0619	1.7357	1.7221	1.7357	1.4581	1.4308
210	Cover	1.0460	1.7335	1.0566	1.7335	1.4571	1.4571
300	▶ Disc	1.4021 <sup>3)</sup>	1.7335 <sup>5)</sup>	1.0566 <sup>4)</sup>	1.7335 <sup>5)</sup>	1.4571 <sup>8)</sup>	1.4571 <sup>8)</sup>
304	▶ Disc	1.0460 <sup>3)</sup>	1.7335 <sup>5)</sup>	1.0566 <sup>4)</sup>	1.7335 <sup>5)</sup>	1.4571 <sup>8)</sup>	1.4571 <sup>8)</sup>
310	▶ Filling piece	1.0035	1.0035	1.0035	1.0035	1.4571	1.4571
314	▶ Disc nut	1.0050	1.0050	1.0050	1.0050	1.4571	1.4571
330	▶ Spring	1.4310	1.4310	1.4310	1.4310	1.4571	1.4571
400	▶ Stem	1.4021	1.4021	1.4571	1.4021	1.4571	1.4571
420	▶ Packing	Graphite	Graphite	Graphite	Graphite	Teflon	Graphite
440	Gland flange	1.0460	1.0460	1.4571	1.0460	1.4571	1.4571
450	Rivet	1.1181	1.1181	A4-50	1.1181	A4-50	A4-50
462	Gland bolt	1.1181	1.1181	1.4571	1.1181	1.4571	1.4571
463	Washer	St	St	A4-50	St	A4-50	A4-50
464	Hexagonal nut	1.1181	1.1181	A4-70	1.1181	A4-70	A4-70
500	▶ Stem nut	1.0718	1.0718	1.0718	1.0718	1.0718	1.0718
501	▶ Cylindrical pin	St	St	St	St	St	St
510	▶ Yoke sleeve	1.0718	1.0718	1.0718	1.0718	1.0718	1.0718
511	▶ Bearing	WLS	WLS	WLS	WLS	WLS	WLS
590	Grease nipple	5.8	5.8	5.8	5.8	5.8	5.8
600	Handwheel	5.3106	5.3106	5.3106	5.3106	5.3106	5.3106
600	Handwheel	5.3106	5.3106	5.3106	5.3106	5.3106	5.3106
609	Washer	St	St	St	St	A4-50	A4-50
610	Hexagonal nut	1.1181	1.1181	1.1181	1.1181	A4-70	A4-70
710	Anti-rotation device	5.3106	5.3106	5.3106	5.3106	5.3106	5.3106

▶ Spare parts      Special materials on request; alterations reserved.

1) PN 10-40      4) Seat hard faced with Cr17      9) ≥ PN 63 seat hard faced with hastelloy  
2) PN 63-160      5) Seat hard faced with stellite  
3) Seat hard faced ≥ DN 125, 1.0460 seat hard faced with Cr17      8) ≥ PN 63 seat hard faced with stellite

Dimensions/mm								
PN	DN	FL L	BW L	H	Stroke h	H1	D	H2
10-40	65	290	290	310	22	105	225	330
	80	310	310	360	25	115	280	390
	100	350	350	400	30	140	280	400
	125	400	400	465	40	145	360	495
	150	480	480	530	50	170	360	530
	200	600	600	575	65	240	450	575
63-160	65	340	340	360	22	120	280	360
	80	380	380	400	25	145	280	400
	100	430	430	410	30	165	360	410
63	125	500	500	535	40	210	360	535
	150	550	550	555	50	235	450	555
100	125	500	500	535	40	210	360	535
	150	550	550	555	50	235	450	555

Weights/kg									
DN	200 AE / BE								
	PN 10-16 FL	PN 25-40 FL	PN 10-40 BW	PN 63 FL	PN 63 BW	PN 100 FL	PN 100 BW	PN 160 FL	PN 160 BW
65	27,5	27,5	16,0	34,0	24,0	34,0	24,0	39,0	24,0
	37,0	37,0	28,0	47,0	36,0	47,0	36,0	51,0	36,0
	52,0	53,0	41,0	72,0	56,0	72,0	56,0	80,0	56,0
	69,0	69,0	55,0	117,0	93,0	120,0	93,0		
	103,0	110,5	97,0	160,0	125,0	166,0	125,0		
	171,0	175,0	156,0						
DN	240 MT								
	PN 10-16 FL	PN 25-40 FL	PN 10-40 BW	PN 63 FL	PN 63 BW	PN 100 FL	PN 100 BW	PN 160 FL	PN 160 BW
65	18,5	18,5	11,5	29,0	13,0	29,0	13,0	33,0	13,0
	29,6	29,6	20,4	42,0	23,0	42,0	23,0	46,0	23,0
	35,4	35,4	29,0	63,0	38,0	63,0	38,0	71,0	38,0
	58,0	58,0	40,0	101,0	78,0	106,0	78,0		
	80,0	80,0	65,0	145,0	110,0	150,0	110,0		
	145,0	160,0	148,0						

Kvs-values (m <sup>3</sup> /h) BW- and FL-version						
Line	DN 65	DN 80	DN 100	DN 125	DN 150	DN 200
	PN 10-160	PN 10-160	PN 10-160	PN 10-160	PN 10-160	PN 10-40
200 AE / AJ	71,0	122,0	162,0	260,0	370,0	660,0
200 BE / BJ	61,5	78,0	104,0	171,0	250,0	422,0
240 MT	72,1	105,9	171,6	263,0	374,0	688,0

The valves are also available in angle pattern up to DN 100 nominal sizes > DN 200 on request.

Permissible differential pressure (pressure inlet below the disc) acc. to EN 13709. **DN bar** 65 80 100 125 150 200 110 70 44 33 21 14



- **Globe valves** ▪ VALTRA Bellow seal globe valve ▪ 200 AL ▪ PN 10-160 ▪ DN 15-50
- **Globe valves** ▪ VALTRA Bellow seal globe valve ▪ 200 AL ▪ PN 10-40 (63-160) ▪ DN 65-400 (DN 65-200)

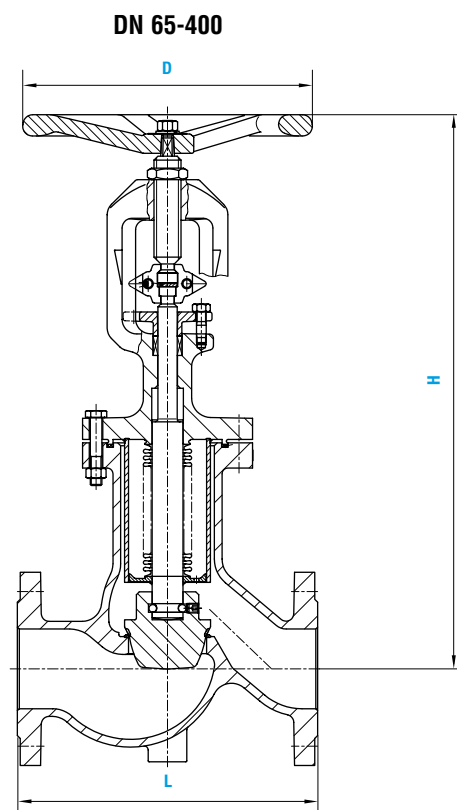
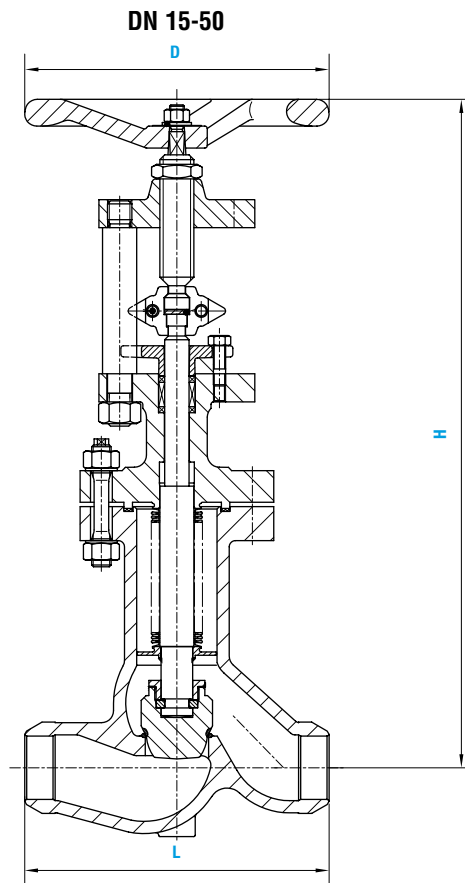

- **Globe valves** ▪ VALTRA Bellow seal globe valve ▪ 200 AL ▪ PN 10-160 ▪ DN 15-50
- **Globe valves** ▪ VALTRA Bellow seal globe valve ▪ 200 AL ▪ PN 10-40 (63-160) ▪ DN 65-400 (DN 65-200)

Materials				
Component	1.0619	1.4408	1.1138	
Body	1.0619	1.4408	1.1138	
welded on with	1.4370 <sup>1)</sup>	Stellite	1.4370 <sup>1)</sup>	
Bonnet	1.0619	1.4408 / 1.4571	1.1138 / 1.0566	
Disc	1.4021 <sup>2)</sup>	1.4571	1.4571 / 1.0566	
welded on with	1.4021 <sup>1)</sup>	Stellite	Stellite	
Bellow seal	1.4571	1.4571	1.4571	
Gasket	1.4571 Graphite layer			
Bolt	A2-70 <sup>3)</sup>	A2-70 <sup>5)</sup>	A2-70 <sup>5)</sup>	
Hexagonal nut	A2-70 <sup>4)</sup>	A2-70 <sup>5)</sup>	A2-70 <sup>5)</sup>	
Stuffing box	Pure graphite			
Gland flange	1.4408 <sup>6)</sup>	1.4408	1.4408	
Stem upper part	1.4122	1.4122	1.4122	
Stem lower part	1.4571	1.4571	1.4571	
Handwheel	0.6020	0.6020	0.6020	

1) ≥ PN 63 Stellite  
 2) ≥ PN 63 1.4571  
 3) ≥ PN 63 1.7709  
 4) ≥ PN 63 1.7218  
 5) ≥ PN 63 A4-70  
 6) ≥ DN 65 1.0420

Dimensions/mm					
PN	DN	FL L	BW L	H/open	D
40	15	130	130	290	150
	20	150	130	290	150
	25	160	130	300	150
	32	180	160	335	175
	40	200	180	340	175
	50	230	210	360	200
	65	290	290	460	200
	80	310	310	610	250
	100	350	350	610	300
	125	400	400	615	300
	150	480	480	645	400
	200	600	600	910	400
	250	730	730	1280	600
	300	850	850	1285	600
350	980	980	1675	600	
400	1100	1100	1685	600	
63	15	210	210	300	150
	20	230	230	300	150
	25	230	230	300	150
	32	260	260	335	175
	40	260	260	340	175
	50	300	300	360	200
	65	340	340	460	200
	80	380	380	610	300
	100	430	430	610	300
	125	500	500	615	300
	150	550	550	945	400
	200	650	650	910	400
100-160	15	210	210	375	175
	20	230	230	375	175
	25	230	230	375	175
	32	260	260	410	250
	40	260	260	410	250
	50	300	300	560	250
	65	340	340		
	80	380	380	880	400
100	430	430	880	400	
125	500	500	890	400	
100	150	550	550	1080	400
	200	650	650	1045	400
160	150	550	550	1140	400
	200	650	650	1140	400

Weights/kg			
PN	DN	FL	BW
40	15	7	6
	20	8	7
	25	8	7
	32	12	10
	40	14	11
	50	17	13
	65	26	18
	80	40	30
	100	56	38
	125	86	72
	150	155	130
	200	255	215
	250	393	325
	300	492	444
350	800	720	
400	1020	890	

▪ **Globe valves** ▪ High pressure globe valve HD 91 ▪ 200 JM ▪ PN 320 ▪ DN 10-65/50



**ASME**  
version  
available

**Range of application**

Admissible operating pressure [bar] at design temperature [°C] <sup>1)</sup>

Material	PN	-10	20	50	100	120	150	200	250	300	350	400	410	420	430	440	450	460	470	480	490	500	510	520	530	540	550	560	570	580 <sup>2)</sup>	590 <sup>2)</sup>	600 <sup>2)</sup>			
<b>1.0460</b>	160	160	160	160	160	160	160	151	132	118	99	80	76	73	69	65	61	54	45	37															
	250	250	250	250	250	250	250	235	206	184	155	125	119	113	107	102	96	85	71	58															
	320	320	320	320	320	320	320	302	264	236	198	160	153	145	138	130	123	109	91	75															
<b>1.5415</b>	160	192	192	192	192	192	192	179	165	141	137	132	131	130	129	128	127	126	125	124	109	85	64	51	41										
	250	300	300	300	300	300	300	280	258	221	213	206	205	203	202	200	199	197	196	194	170	132	101	79	64										
	320	320	320	320	320	320	320	320	320	283	273	264	262	260	258	256	255	253	251	249	217	170	129	102	81										
<b>1.7335</b>	160	192	192	192	192	192	192	189	174	165	156	154	152	150	148	146	145	144	143	142	129	109	86	70	57	44	36	29							
	250	300	300	300	300	300	300	294	272	258	243	240	237	234	231	228	227	225	224	222	202	170	134	109	88	69	57	46							
	320	320	320	320	320	320	320	320	320	320	311	307	304	300	296	292	290	289	287	285	258	217	172	140	113	88	72	59							
<b>1.7383 <sup>2)</sup></b>	160	192	192	192	192	192	192	189	174	165	163	161	159	157	156	154	152	150	143	127	111	97	85	74	64	55	48	41	36	32					
	250	300	300	300	300	300	300	300	294	272	258	255	252	249	246	243	240	237	234	224	199	174	152	132	115	100	85	75	65	56	49				
	320	320	320	320	320	320	320	320	320	320	320	319	315	311	307	304	300	287	285	223	194	170	147	128	109	96	83	72	63						

1) Operating temperature = design temperature minus temperature surcharge acc. to DIN regulations.

2) For temperatures > 570 °C, stem in 1.4923 and high-temperature-packing.

## ■ **Globe valves** ■ High pressure globe valve HD 91 ■ 200 JM ■ PN 320 ■ DN 10-65/50

### Standard features

- Disc and stem in one piece
- Die-forged valve body
- Non-turning, rising stem
- Position indicator
- Throttle disc
- Yoke sleeve supported by needle bearings
- Possibility to add an actuator-flange

### Pressure and temperature ratings

- Pressure rating 320 bar
- Temperature rating from -10 °C up to 600 °C

### Materials

- 1.0460
- 1.5415
- 1.7335
- 1.7383

Further materials on request.

### Media

Depending on the material the globe valves are suitable for water, gas, oil and other non aggressive media

### Fields of application

High temperature steam and water, refining (catalytic reformers and hydrocrackers), petrochemical and chemical industries, power plants

### Design Highlights

- Body seat: edge seat welded on integrately with stellite
- Disc / stem single piece of material > 570 °C with stellite edge seat
- Sealing to the outside only means of the gland packing
- Body and bonnet in two separate pieces with bolted connection
- Yoke sleeve supported by needle bearings (axial type)
- Possibility to add an actuator-flange

### Benefits

- No pressed in or screwed seat ring, therefore no crevice corrosion or loosening
- No damages between disc and stem because of high flow velocity
- No bonnet gaskets, therefore reduction of possible leakage areas
- To ease maintenance work, e.g. regrinding of the body seats
- To minimize the expenditure of effort when operating valve
- Simple retrofitting of an electric actuator possible

▪ **Globe valves** ▪ **High pressure globe valve HD 91** ▪ **200 JM** ▪ **PN 320** ▪ **DN 10-65/50**

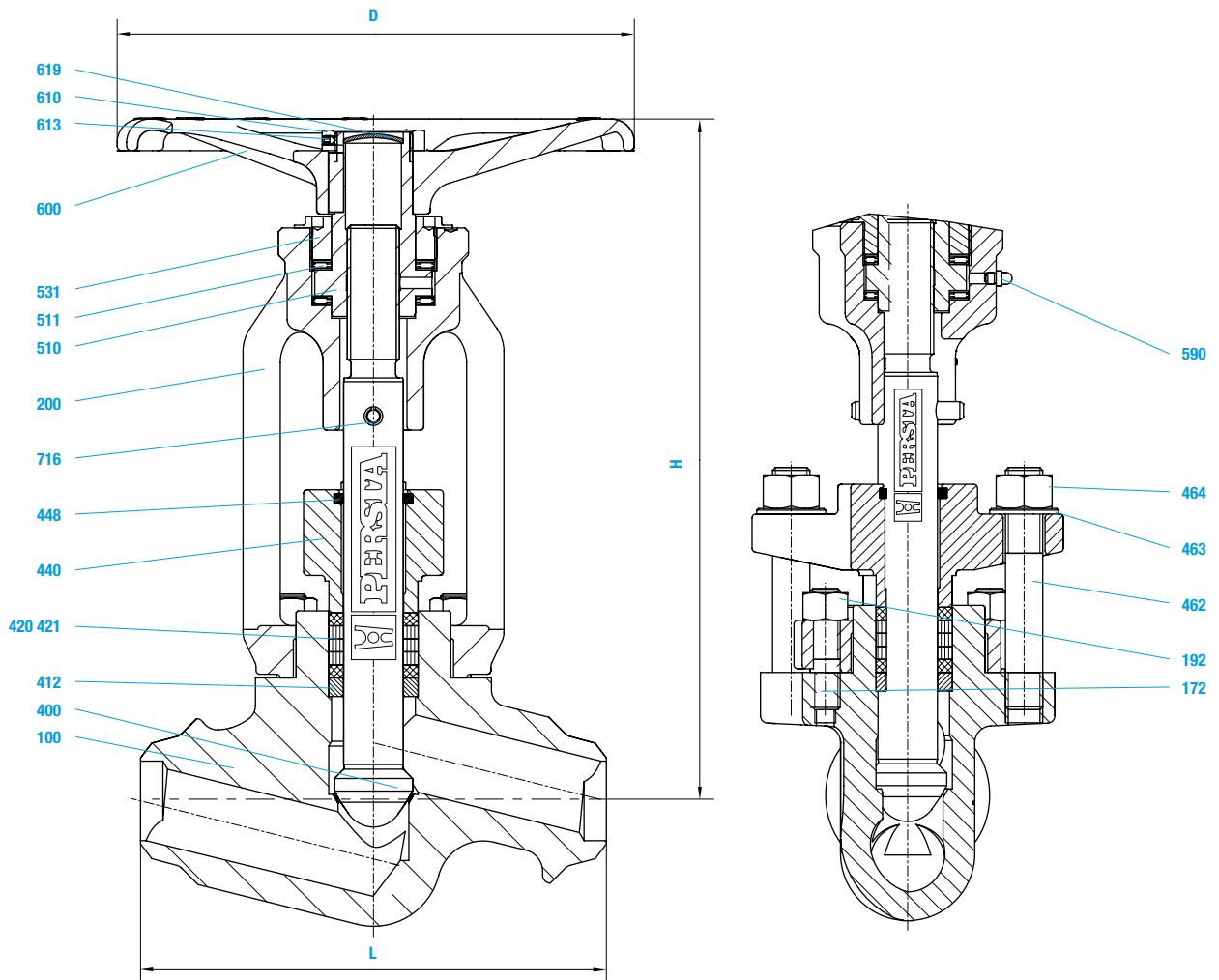

■ **Globe valves** ■ High pressure globe valve HD 91 ■ 200 JM ■ PN 320 ■ DN 10-65/50

Materials					
Pos.	Component	1.0460 (21)	1.5415 (42)	1.7335 (44)	1.7383 (45)
100	Body welded on with	1.0460	1.5415	1.7335	1.7383
172	Stud	Stellite	Stellite	Stellite	Stellite
192	Hexagonal nut	1.7709	1.7709	1.7709	1.7709
200	Bonnet	1.7218	1.7218	1.7218	1.7218
400	▶ Stem	1.7379	1.7379	1.7379	1.7379
412	▶ Guide sleeve	1.4122 <sup>1)</sup>	1.4122 <sup>1)</sup>	1.4122 <sup>1)</sup>	1.4122 <sup>1)2)</sup>
420 / 421	▶ Packing	0.7660	0.7660	0.7660	0.7660
440	▶ Gland flange	Pure graphite	Pure graphite	Pure graphite	Pure graphite <sup>2)</sup>
448	▶ Dirt scraper	1.7379	1.7379	1.7379	1.7379
462	▶ Stud	Graphite plait	Graphite plait	Graphite plait	Graphite plait
463	▶ Washer	1.7709	1.7709	1.7709	1.7709
464	▶ Hexagonal nut	St	St	St	St
510	▶ Yoke sleeve	1.7218	1.7218	1.7218	1.7218
511	▶ Bearing	CW 713 R	CW 713 R	CW 713 R	CW 713 R
531	▶ Screwing	WLSt	WLSt	WLSt	WLSt
590	▶ Grease nipple	1.0460	1.0460	1.0460	1.0460
600	▶ Handwheel	5.8	5.8	5.8	5.8
610	▶ Hexagonal nut	5.3106	5.3106	5.3106	5.3106
613	▶ Screw pin	St	St	St	St
619	▶ Lock washer	45H	45H	45H	45H
716	▶ Tension pin	ST	ST	ST	ST
		1.0904	1.0904	1.0904	1.0904

▶ Spare parts

1) On request stem in 1.4923 with stellite seats  
2) For temperatures > 570 °C stem with stellite seats in 1.4923 and hightemperature-packing

Dimensions/mm					
DN	L	H	Stroke	R/Stroke	DIN/ISO D 5210
10	150	208	10	5	140 F07/F10
15	150	208	10	5	140 F07/F10
20	160	250	16	8	180 F10
25	160	250	16	8	180 F10
32	250	415	27	9	280 F10/F14
40	250	415	27	9	280 F10/F14
50	250	415	27	9	280 F10/F14
65 / 50	250	415	27	9	280 F10/F14

**Attention: In case of welding connections the permissible operating overpressure is valid for the corresponding tube dimension.**

Weights/kg and Kvs-values		
DN	BW	Kvs (m <sup>3</sup> /h)
10	4	2,3
15	4	3,4
20	6,9	6,2
25	6,9	7,9
32	23	20,0
40	23	24,1
50	23	28,3
65 / 50	23	28,3

- **Globe valves** ▪ High pressure globe valve HD 2000 ▪ 200 LM ▪ PN 500 ▪ DN 10-65
- **Globe valves** ▪ Lift check valve HD 2000 ▪ 240 MT ▪ PN 500 ▪ DN 10-65



**ASME**  
version  
available

**Range of application**

Admissible operating pressure [bar] at design temperature [°C] <sup>1)</sup>

Material	PN	20	50	100	120	150	200	250	300	350	400	410	420	430	440	450	460	470	480	490	500	510	520	530	540	550	560	570	580 <sup>2)</sup>	590 <sup>2)</sup>	600 <sup>2)</sup>	610 <sup>2)</sup>	620 <sup>2)</sup>	630 <sup>2)</sup>	640 <sup>2)</sup>	650 <sup>2)</sup>				
<b>1.0460</b>	500	550	550	550	550	550	550	518	463	389	315	300	285	270	255	240	213	177	146																					
<b>1.5415</b>	500	550	550	550	550	550	550	550	550	537	518	514	510	507	503	500	496	493	489	426	333	253	200	160																
<b>1.7335</b>	500	550	550	550	550	550	550	550	550	550	550	550	550	550	550	550	550	550	550	550	500	426	338	275	222	173	142	116												
<b>1.7383<sup>2)</sup></b>	500	550	550	550	550	550	550	550	550	550	550	550	550	550	550	550	550	550	550	550	500	437	381	333	289	252	214	189	163	140	124									
<b>1.4903<sup>2)</sup></b>	500	550	550	550	550	550	550	550	550	550	550	550	550	550	550	550	550	550	550	550	550	550	550	550	550	550	550	500	465	430	380	338	298	261	231	198	172			
<b>1.4901<sup>2)</sup></b>	500	550	550	550	550	550	550	550	550	550	550	550	550	550	550	550	550	550	550	550	550	550	550	550	550	550	550	550	550	526	470	419	370	322	278	241	207			
<b>1.4550</b>	500	550	550	550	550	550	550	544	504	481	463	460	456	454	451	449	447	445	443	442	441	440	439	438	437	437	436	435	434	433	396	363	320	271	240	207				

1) Operating temperature = design temperature minus temperature surcharge acc. to DIN regulations.

2) For temperatures > 570 °C, stem in 1.4980 and high-temperature-packing.

- **Globe valves** ▪ High pressure globe valve HD 2000 ▪ 200 LM ▪ PN 500 ▪ DN 10-65
- **Globe valves** ▪ Lift check valve HD 2000 ▪ 240 MT ▪ PN 500 ▪ DN 10-65

### Standard features

- Disc and stem in one piece
- Die-forged valve body
- Non-turning, rising stem
- Position indicator / Anti-rotation device
- Throttle disc
- Yoke sleeve supported by needle bearings
- Greater than DN 20 with integral actuator flange
- Back seat type available (200 LS / 200 LJ)
- All HD 2000 valves also available in angle pattern (e.g. 202 LM)

### Pressure and temperature ratings

- Pressure rating up to 550 bar
- Temperature rating from -10 °C up to 650 °C (depending on selected material)

### Materials

- 1.0460
- 1.4550
- 1.4901
- 1.4903
- 1.5415
- 1.7335
- 1.7383 Further materials on request.

### Media

Depending on the material the valves are suitable for water, gas, oil and other non aggressive media

### Fields of application

High temperature steam and water, refining (catalytic reformers and hydrocrackers, petrochemical and chemical industries)

### Design Highlights

- Body seat: tapered seat welded on integrally with stellite
- Disc and stem in one piece; up from 570 °C with stellite tapered seat
- Sealing to the outside only by means of the gland packing
- Body and bonnet in two separate pieces with bolted connection
- Yoke sleeve made of bronze
- Cup springs above the upper needle bearing

### Benefits

- No pressed in or screwed seat ring, therefore no crevice corrosion or loosening
- Damage between disc and stem due to high flowrates is prevented
- No bonnet gasket, therefore reduction of possible leakage areas
- To ease maintenance work, e.g. regrinding of the body seats
- Good emergency running properties
- To maintain the necessary closing forces when dimensions change between stem and yoke arms due to thermal fluctuation



▪ **Globe valves** ▪ High pressure globe valve HD 2000 ▪ 200 LM ▪ PN 500 ▪ DN 10-65

200 LM Shut-off globe valve

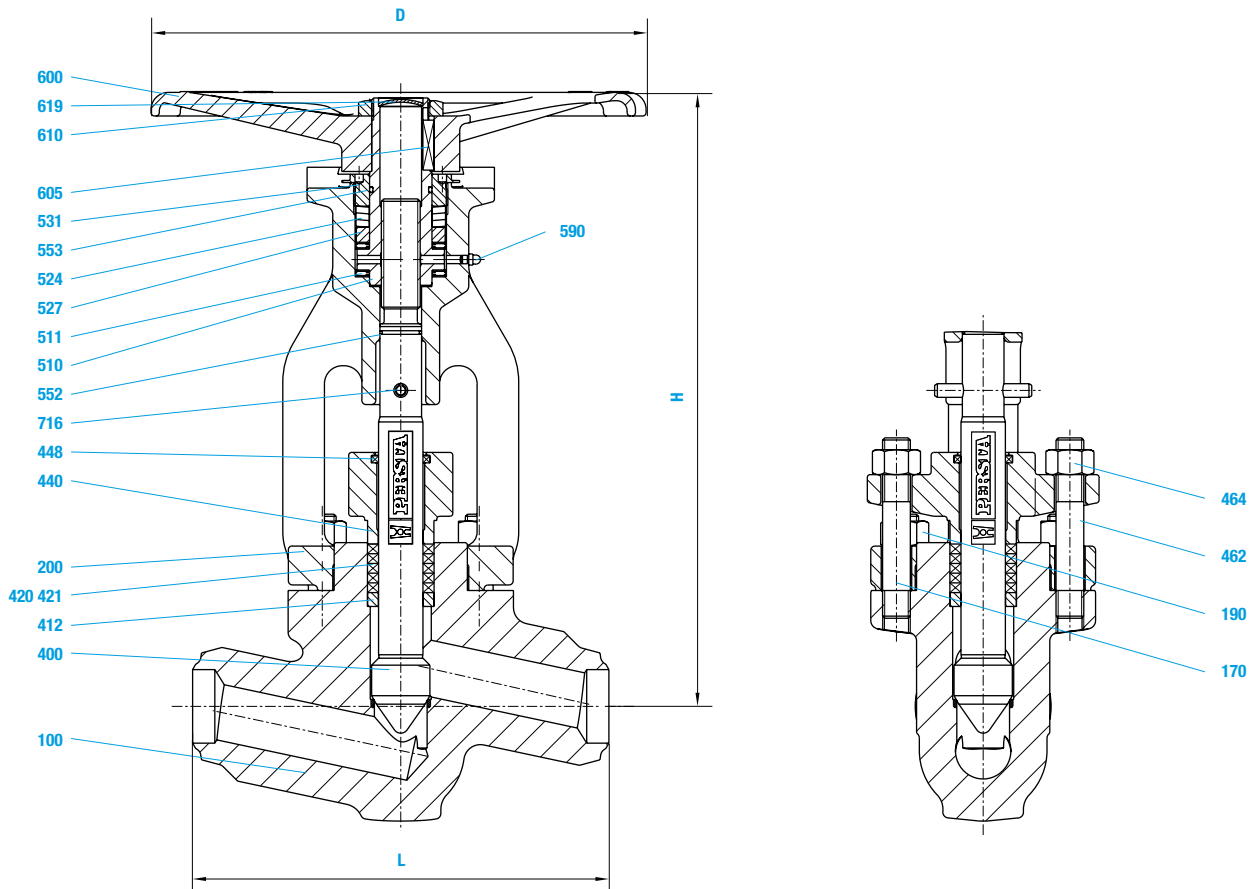



- **Globe valves** ▪ High pressure globe valve HD 2000 ▪ 200 LS ▪ PN 500 ▪ DN 10-65
- **Globe valves** ▪ Stop check valve ▪ 240 MM ▪ PN 500 ▪ DN 10-65
- **Globe valves** ▪ Lift check valve HD 2000 ▪ 240 MT ▪ PN 500 ▪ DN 10-65

**240 MM Stop check valve**  
also available in angle pattern

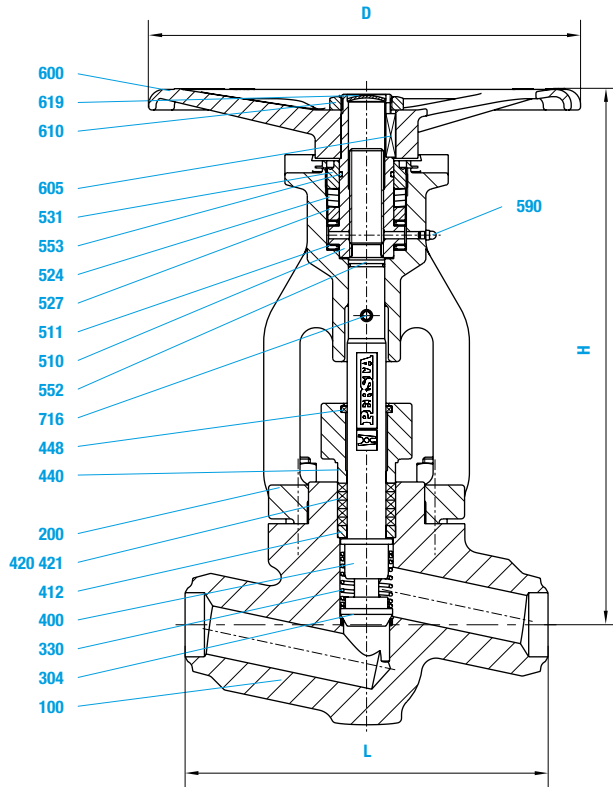

**200 LS globe valve with back seat**  
also available in angle pattern

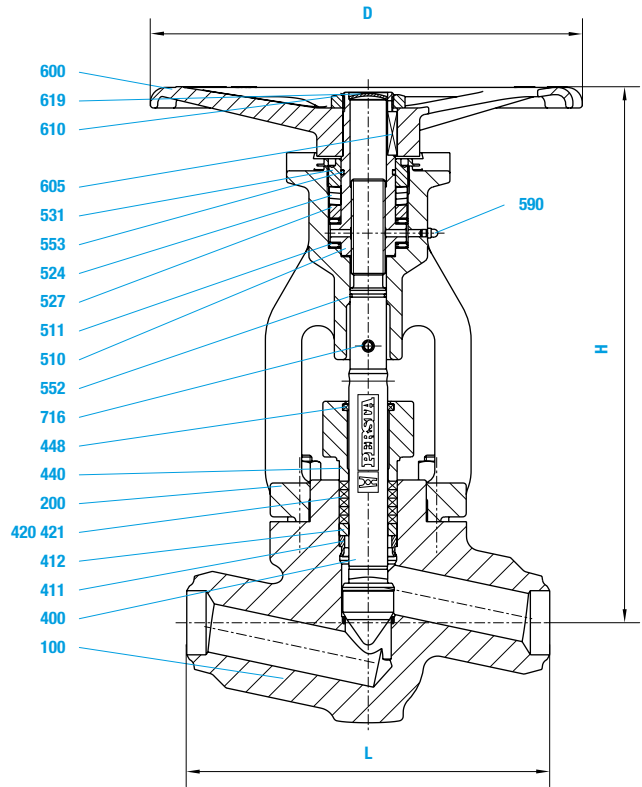

**240 MT Lift check valve**  
also available in angle pattern

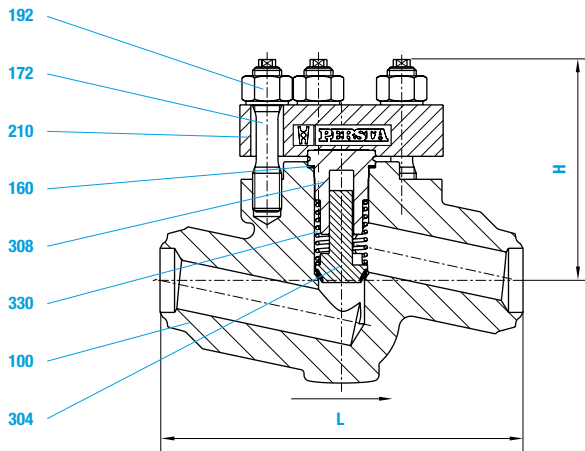

- **Globe valves** ▪ High pressure globe valve HD 2000 ▪ 200 LM/LS ▪ PN 500 ▪ DN 10-65
- **Globe valves** ▪ Stop check valve ▪ 240 MM ▪ PN 500 ▪ DN 10-65
- **Globe valves** ▪ Lift check valve HD 2000 ▪ 240 MT ▪ PN 500 ▪ DN 10-65

Materials								
Pos.	Component	1.0460 (21)	1.5415 (42)	1.7335 (44)	1.7383 (45) <sup>2)</sup>	1.4903 (63) <sup>2)</sup>	1.4901(66) <sup>2)</sup>	1.4550 (89)
100	Body welded on with	1.0460	1.5415	1.7335	1.7383	1.4903	1.4901	1.4550
		Stellite	Stellite	Stellite	Stellite	Stellite	Stellite	Stellite
160	▶ Gasket	Graphite	Graphite	Graphite	Graphite	Graphite	Graphite	Graphite
170	Stud	1.7709	1.7709	1.7709	1.7709	1.4923	1.4923	1.4980
172	Stud	1.4923	1.4923	1.4923	1.4923	1.4986	1.4986	1.4986
190	Hexagonal nut	1.7218	1.7709	1.7218	1.4986	1.4986	1.4923	1.4986
192	Hexagonal nut	1.4923	1.4923	1.4923	1.4923	1.4986	1.4986	1.4986
200	Bonnet	1.7379	1.7379	1.7379	1.7379	1.7379	1.7379	1.7379 <sup>3)</sup>
210	Cover	1.7380	1.7380	1.7380	1.7380	1.4903	1.4901	1.4550
304	▶ Disc	1.4923	1.4923	1.4923	1.4923	1.4923	1.4923	1.4980
308	Guide bush	1.4923	1.4923	1.4923	1.4923	1.4980	1.4980	1.4980
330	Pressure spring	2.4669	2.4669	2.4669	2.4669	2.4699	2.4699	2.4669
400	▶ Stem	1.4122 <sup>1)</sup>	1.4122 <sup>1)</sup>	1.4122 <sup>1)</sup>	1.4122 <sup>1)2)</sup>	1.4122 <sup>1)2)</sup>	1.4122 <sup>1)2)</sup>	1.4980 <sup>1)</sup>
411	Back seat ring	1.4980	1.4980	1.4980	1.4980	1.4980	1.4980	1.4980
412	Guide sleeve	0.7660	0.7660	0.7660	0.7660	0.7660	0.7660	0.7660
420	▶ Packing	Pure graphite	Pure graphite	Pure graphite	Pure graphite	Pure graphite	Pure graphite	Pure graphite
421	▶ Thrust ring	Pure graphite	Pure graphite	Pure graphite	Pure graphite	Pure graphite	Pure graphite	Pure graphite
440	Gland flange	1.7379	1.7379	1.7379	1.7379	1.7379	1.7379	1.7379 <sup>3)</sup>
448	▶ Dirt scraper	Graphite plait	Graphite plait	Graphite plait	Graphite plait	Graphite plait	Graphite plait	Graphite plait
462	Stud	1.7709	1.7709	1.7709	1.7709	1.4923	1.4980	1.4980
464	Hexagonal nut	1.7218	1.7218	1.7218	1.7218	1.4923	1.4923	1.4986
510	▶ Yoke sleeve	CW 713 R	CW 713 R	CW 713 R	CW 713 R	CW 713 R	CW 713 R	CW 713 R
511	▶ Bearing	WLSt	WLSt	WLSt	WLSt	WLSt	WLSt	WLSt
524	Spring	1.8159	1.8159	1.8159	1.8159	1.8159	1.8159	1.8159
527	Supporting ring	1.4021	1.4021	1.4021	1.4021	1.4021	1.4021	1.4021
531	Screwing	1.0460	1.0460	1.0460	1.0460	1.0460	1.4122	1.0460
552	▶ O-Ring	Viton	Viton	Viton	Viton	Viton	Viton	Viton
553	▶ O-Ring	Viton	Viton	Viton	Viton	Viton	Viton	Viton
590	Grease nipple	5.8	5.8	5.8	5.8	5.8	5.8	5.8
600	Handwheel	5.3106	5.3106	5.3106	5.3106	5.3106	5.3106	5.3106
605	Key	1.0060	1.0060	1.0060	1.0060	1.0060	1.0060	1.0060
610	Hexagonal nut	St	St	St	St	St	St	St
619	Lock washer	St	St	St	St	St	St	St
716	Tension pin	1.0904	1.0904	1.0904	1.0904	1.0904	1.0904	1.0904

▶ Spare parts

1) On request stem with stellite seats  
 2) For temperatures > 570 °C stem with stellite seats in 1.4980 and high-temperature-packing.  
 3) Nickel plated

Dimensions/mm								
DN	L	L1	H	H1	Stroke	R/ Stroke	D	DIN/ISO 5210
<b>10</b>	150	75	228	99	10	5	140	F07 <sup>1)</sup>
<b>15</b>	150	75	228	99	10	5	140	F07 <sup>1)</sup>
<b>20</b>	180	90	280	122	16	8	225	F10
<b>25</b>	180	90	280	122	16	8	225	F10
<b>32</b>	300	150	445	182	27	9	360	F10/F14
<b>40</b>	300	150	445	182	27	9	360	F10/F14
<b>50</b>	300	150	445	182	27	9	360	F10/F14
<b>65</b>	360	200	563	208	36	12	450	F14/F16

1) Specify flange ends when placing order

Attention: In case of welding connections the permissible operating overpressure is valid for the corresponding tube dimension.

Weights/kg and Kvs-values						
DN	BW 200 LM	BW 202 LM	BW 240 MM	BW 200 LS	BW 240 MT	Kvs (m <sup>3</sup> /h) 200 LM / LS
<b>10</b>	6,0	6,0	6,0	6,0	3,8	2,3
<b>15</b>	6,0	6,0	6,0	6,0	3,8	3,4
<b>20</b>	11,5	11,5	11,5	11,5	7,9	6,2
<b>25</b>	11,3	11,3	11,3	11,3	7,7	7,9
<b>32</b>	47,5	47,5	47,5	47,5	30,5	20,0
<b>40</b>	47,0	47,0	47,0	47,0	30,0	24,1
<b>50</b>	46,5	46,5	46,5	46,5	29,5	28,3
<b>65</b>	107,0	107,0	128,0	107,0	72,0	48,5

- **Globe valves** ▪ **High pressure globe valve DVA 25 / DVA 40** ▪ **200 BZ** ▪ **PD 25 / PD 40** ▪ **DN 80-250**

**ASME**  
version  
available

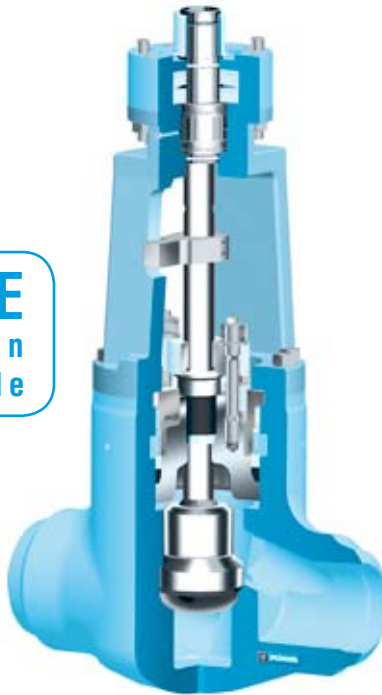

		Range of application																																								
		Admissible operating pressure [bar] at design temperature [°C] <sup>1)</sup>																																								
BW-Version	Material	PD	20	50	100	120	150	200	250	300	350	400	410	420	430	440	450	460	470	480	490	500	510	520	530	540	550	560	570	580	590	600	610	620	630	640	650					
1.0460	25	250	250	250	250	250	235	206	184	155	125	119	113	107	102	96	85	71	58																							
1.5415	25	300	300	300	300	300	280	258	221	213	206	205	203	202	200	199	197	196	194	170	132	101	80	64																		
1.7335	25	300	300	300	300	300	300	294	272	258	243	240	237	234	231	228	227	225	224	222	202	170	134	110	88	69	57	46														
1.7380	25	300	300	300	300	300	300	294	272	258	255	252	249	246	243	240	237	234	224	199	174	152	132	115	100	85	75	65	56	49												
1.6368	25	320	320	320	320	320	320	320	320	320	320	320	320	320	320	320	309	257	205	153	102																					
1.4903	25	320	320	320	320	320	320	320	320	320	320	320	320	320	320	320	320	320	320	320	320	320	316	290	263	238	213	191	169	150	132	115	100	85	75	65						
1.4901	25	320	320	320	320	320	320	320	320	320	320	320	320	320	320	320	320	320	320	320	320	320	320	320	320	297	275	253	231	209	187	166	147	128	110	96	82					

1) Operating temperature = design temperature minus temperature surcharge acc. to DIN regulations.

**Attention: Pressure rating of the materials 1.6368, 1.4903 and 1.4901 was reduced in the "cold" range to 320 bar. This pressure rating is only valid for the DVA 25.**

		Range of application																																										
		Admissible operating pressure [bar] at design temperature [°C] <sup>1)</sup>																																										
BW-Version	Material	PD	20	50	100	120	150	200	250	300	350	400	410	420	430	440	450	460	470	480	490	500	510	520	530	540	550	560	570	580	590	600	610	620	630	640	650							
1.0460	40	400	400	400	400	400	377	330	295	248	200	191	182	172	163	153	136	113	93																									
1.5415	40	480	480	480	480	480	448	413	354	342	330	328	325	323	321	318	316	314	311	272	212	161	127	102																				
1.7335	40	481	481	481	481	481	471	436	413	389	384	380	375	370	365	363	361	358	356	323	272	215	175	141	110	91	74																	
1.7380	40	480	480	480	480	480	480	471	436	413	408	403	398	394	389	384	380	375	358	318	278	243	212	184	160	137	120	104	90	79														
1.6368	40	600	600	600	600	600	600	600	600	600	600	600	600	600	600	600	577	495	412	328	245	163																						
1.4903	40	600	600	600	600	600	600	600	600	600	600	600	600	600	600	600	600	600	600	600	600	600	596	551	506	464	422	382	342	306	271	240	212	184	160	137	120	104						
1.4901	40	600	600	600	600	600	600	600	600	600	600	600	600	600	600	600	600	600	600	600	600	600	600	600	600	553	513	475	440	405	369	334	299	266	235	205	177	153	132					

1) Operating temperature = design temperature minus temperature surcharge acc. to DIN regulations.

**Attention: Pressure rating of the materials 1.6368, 1.4903 and 1.4901 was reduced in the "cold" range to 600 bar. This pressure rating is only valid for the DVA 40.**

▪ **Globe valves** ▪ High pressure globe valve DVA 25 / DVA 40 ▪ 200 BZ ▪ PD 25 / PD 40 ▪ DN 80-250

**Standard features**

- Straight pattern
- Die-forged valve body and bonnet
- Pressure sealing bonnet acc. to VGB-guidelines
- Throttle disc
- Body seat welded on integratedly
- Outside screw and yoke
- Position indicator / Anti-rotation device
- Yoke sleeve supported at the top and the bottom  
By means of needle bearings
- Non-turning, rising stem
- Universal valve head for mounting actuators

**Pressure and temperature ratings**

- Pressure rating up to 600 bar
- Temperature rating up to 650 °C

**Materials**

- 1.0460
- 1.5415
- 1.7335
- 1.7383
- 1.6368
- 1.4903
- 1.4901

Further materials and sizes on request.

**Media**

Depending on the material the globe valves are suitable for water, gas, oil and other non aggressive media

**Fields of application**

Chemical industries, industries and power plant.

**Design Highlights**

- Die-forged body and bonnet
- Pressure sealing bonnet
- Body seat welded on integratedly with stellite
- Extended bonnet
- Outside located anti twist device
- Non-turning, rising stem
- Gland flange and gland ring in two separate pieces
- Yoke sleeve supported by needle bearings
- Cup springs above the upper needle bearing

**Benefits**

- Free from porosity and shrink holes
- Best possible sealing function
- Extremely resistant to wear
- To reduce temperatures
- Usable as position indicator
- Minimum packing wear
- Damage to the stem by irregular tightening of gland bolts is avoided
- To minimize the expenditure of effort when operating the valve
- To maintain the necessary closing forces at elongation changes between stem and yoke arms due to thermal changes. Also to protect against excess torsion when electric actuators are fitted.

▪ **Globe valves** ▪ High pressure globe valve DVA 25 / DVA 40 ▪ 200 BZ ▪ PD 25 / PD 40 ▪ DN 80-250

**DVA 25 ▪ PD 25 ▪ DN 80-250**

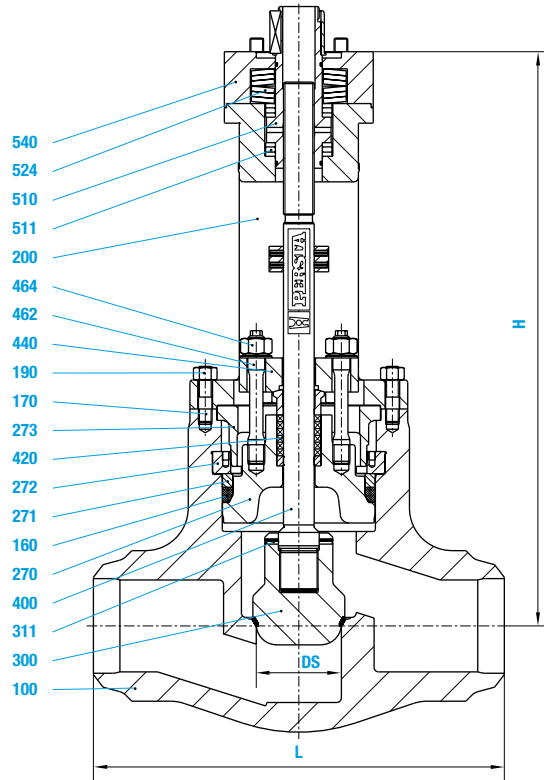

**DVA 40 ▪ PD 40 ▪ DN 80-200**

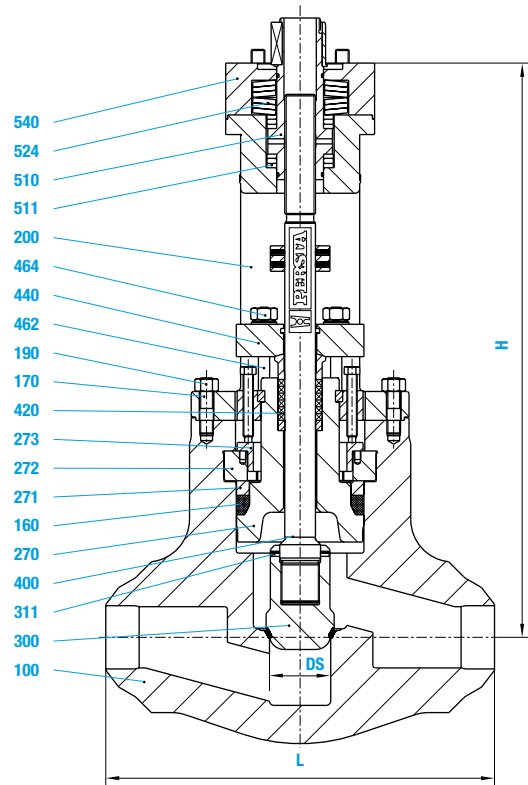

■ **Globe valves** ■ High pressure globe valve DVA 25 / DVA 40 ■ 200 BZ ■ PD 25 / PD 40 ■ DN 80-250

Materials								
Pos.	Component	1.0460 (21)	1.5415 (42)	1.7335 (44)	1.7383 (45)	1.6368 (46)	1.4903 (63)	1.4901 (66)
100	Body welded on with	1.0460 Stellite	1.5415 Stellite	1.7335 Stellite	1.7383 Stellite	1.6368 Stellite	1.4903 Stellite	1.4901 Stellite
160	▶ Gasket	Graphite	Graphite	Graphite	Graphite	Graphite	Graphite	Graphite
170	Stud	1.7709	1.7709	1.7709	1.7709	1.4923	1.4923	1.4923
190	Hexagonal nut	1.7218	1.7218	1.7218	1.7218	1.7218	1.7218	1.7218
200	Bonnet	1.7379	1.7379	1.7379	1.7379	1.7379	1.7379	1.7379
270	Cover	1.7383	1.7383	1.7383	1.7383	1.4903	1.4903	1.4901
271	Thrust ring	1.7383	1.7383	1.7383	1.7383	1.4903	1.4903	1.4901
272	Segmentring	1.7383	1.7383	1.7383	1.7383	1.4903	1.4903	1.4901
273	Cover	1.5419	1.5419	1.5419	1.5419	1.5419	1.5419	1.5419
300	▶ Disc welded on with	1.4903 Stellite	1.4903 Stellite	1.4903 Stellite	1.4903 Stellite	1.4903 Stellite	1.4903 Stellite	1.4901 Stellite
311	Grooved pin	1.4571	1.4571	1.4571	1.4571	1.4571	1.4571	1.4571
400	▶ Stem	1.4122	1.4122	1.4122	1.4122	1.4923	1.4923	1.4980
400	▶ Stem up to 500°C			1.4980*	1.4980		1.4980	
420	▶ Packing	Graphite	Graphite	Graphite	Graphite	Graphite	Graphite	Graphite
440	Gland flange	1.7380	1.7380	1.7380	1.7380	1.7380	1.7380	1.7380
462	Stud	1.7709	1.7709	1.7709	1.7709	1.4923	1.4923	1.4923
464	Hexagonal nut	1.7218	1.7218	1.7218	1.7218	1.4923	1.4923	1.4923
510	▶ Yoke sleeve	CW713R	CW713R	CW713R	CW713R	CW713R	CW713R	CW713R
511	▶ Bearing	WLS	WLS	WLS	WLS	WLS	WLS	WLS
524	Spring	Spring Steel	Spring Steel	Spring Steel	Spring Steel	Spring Steel	Spring Steel	Spring Steel
540	Flange	1.0460	1.0460	1.0460	1.0460	1.0460	1.0460	1.0460

▶ Spare parts

\* In PD 25 up to DN 150  
\* In PD 40 up to DN 125

Dimensions/mm DVA 25							
DN	DS	L	H	Stroke	R/Stroke	H-Wheel	DIN/ISO 5210
80	64	305	450 (475)	32	11	450	F10 (F14)
100	82	406	575	42	14	500	F14
125	100	483	675 (725)	51	17	600	F14 (F16)
150	122	559	800 (850)	62	21	720	F16 (F25)
200	160	711	950 (1000)	82	27		F25 (F30)
250	190	864	1075 (1150)	96	24		F30 (F35)

Weights/kg and Kvs-values DVA 25		
DN	BW	Kvs (m <sup>3</sup> /h)
80	69	71
100	132	95
125	200	141
150	378	210
200	615	362
250	1120	510

Dimensions/mm DVA 40							
DN	DS	L	H	Stroke	R/Stroke	H-Wheel	DIN/ISO 5210
80	57	368	575	28	9	500	F14
100	72	359	675 (725)	38	13	600	F14 (F16)
125	90	533	800 (850)	45	15	720	F16 (F25)
150	111	610	950 (1000)	57	19		F25 (F30)
200	146	762	1075 (1150)	75	19		F30 (F35)

Weights/kg and Kvs-values DVA 40		
DN	BW	Kvs (m <sup>3</sup> /h)
80	145	45
100	225	73
125	430	114
150	715	174
200	1140	300



▪ **Globe valves** ▪ **Further standards**

**Screw down non return valve 240 ME**

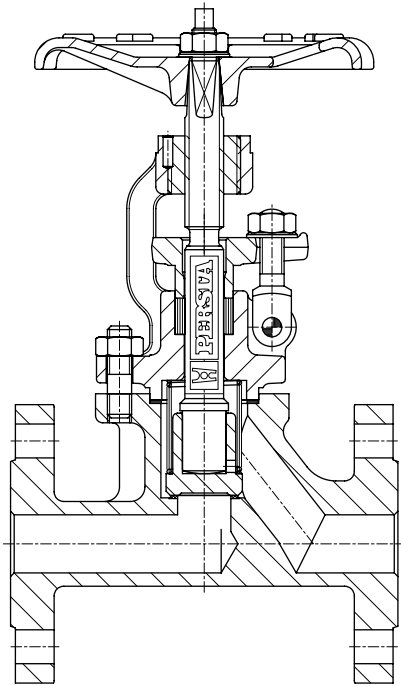

**Angle globe valve 202 AE**

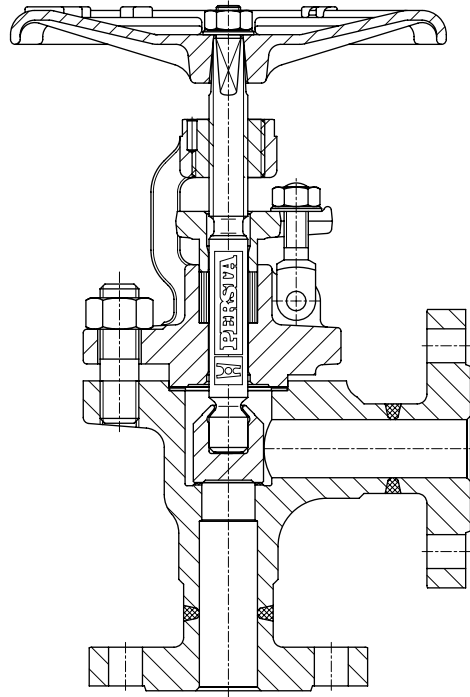

**Changeover valve 203 EM**

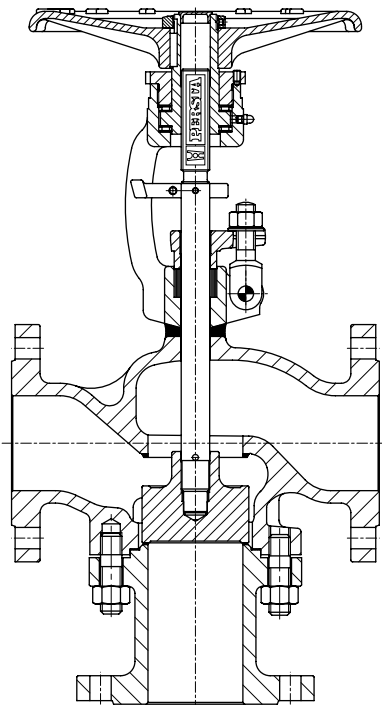

■ **Globe valves** ■ **Actuator variants**

**Universal Valve-Head**

For subsequent assembly of E-actuators without welding

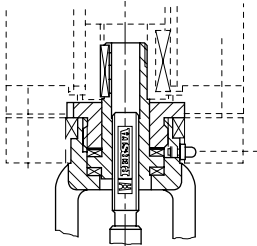

**Assembly of E-actuators**

Standard design DN 65

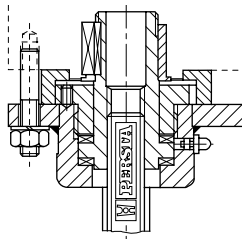

For running a particular limit of travel e.g. with air or current

**Example**

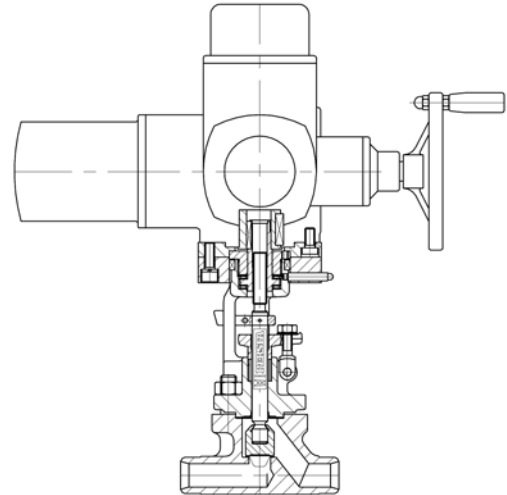

**PERCON piston drive**

Spring opening

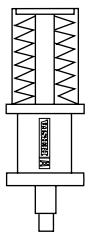

**PERCON piston drive**

Spring closing

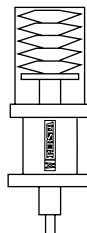

**Example**

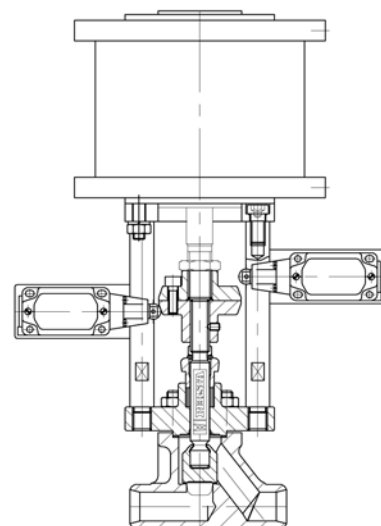

■ **Globe valves** ■ **Variants**

**Disc with edge seat**

For media with small quantities of impurities

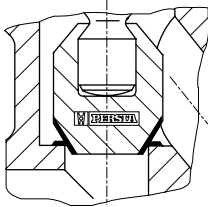

**Disc with soft seat**

E.g. of lead or PTFE for crystallizing media etc.

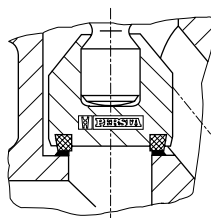

**Disc with elastomer coated obturator**

E.g. with PTFE spacer ring for special media up to approx. 280 °C

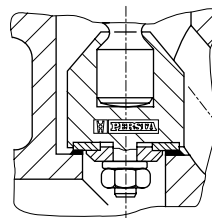

**Control disc**

Pinned down suitable for operating in intermediate position

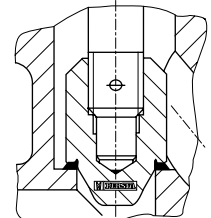

**PTFE-stuffing box**

With chambers for aggressive media up to approx. max. 280 °C

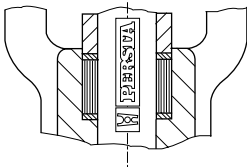

**Stuffing box with lantern and test screw plug**

Also for sealing water or leakage suction

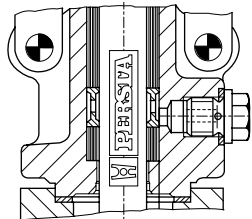

**Stuffing box with central cup spring tightening**

In order to minimize maintenance costs

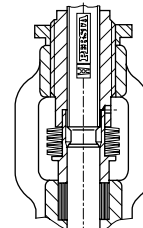

**Hard faced back seat**

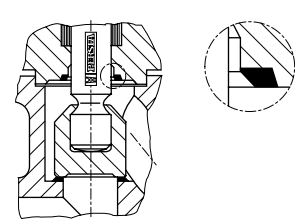

**Limit switches**

Can be supplied mechanically or inductively

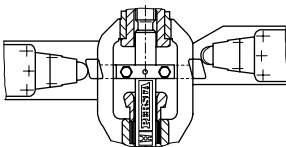

**On-Off position indicator**

With sheet metal bracket

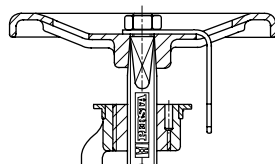

**Non-rotating stem**

In order to reduce packing wear

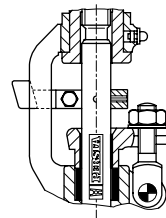

**Stem extension**

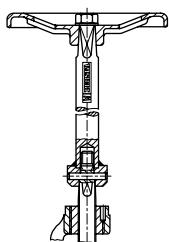

**PERLOC system locking mechanism**

Also for interlocking mechanism (safety circuits)

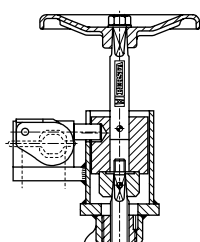

**Locking mechanism**

With padlock

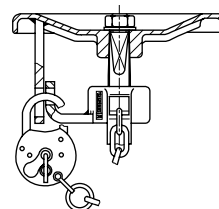

■ **Globe valves** ■ **Special valves**

**Y-pattern stop check valve**

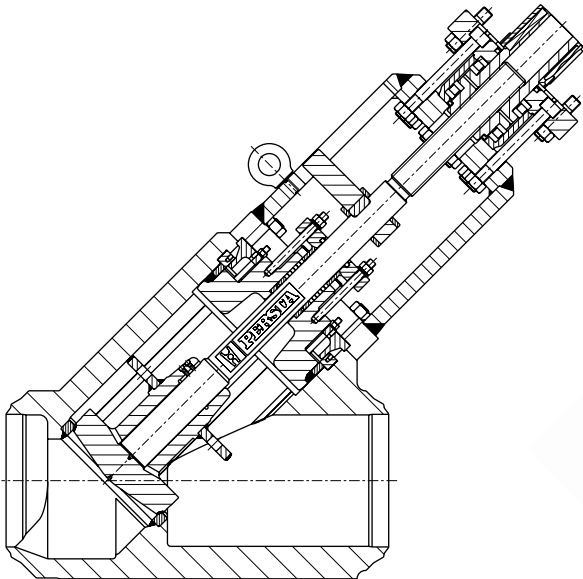

**Bellow seal Y-valve**

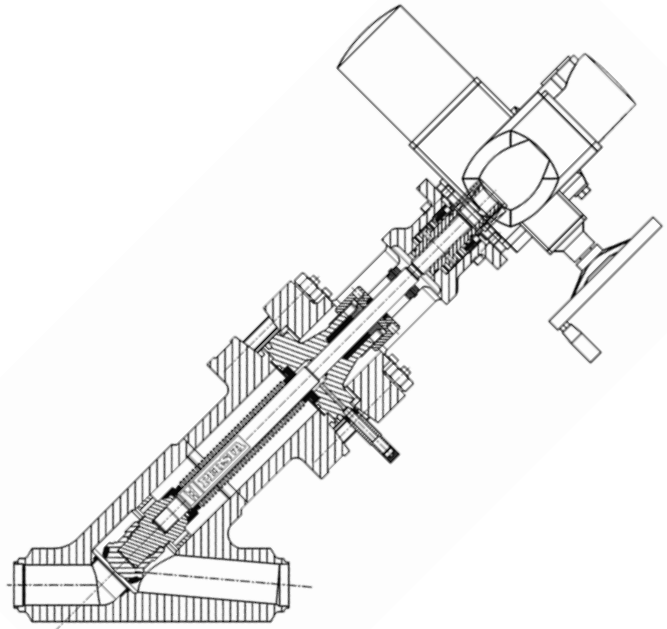

**Globe valve with insulating section**

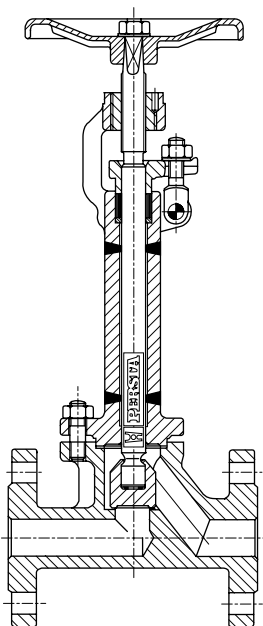

**Monobloc valve**

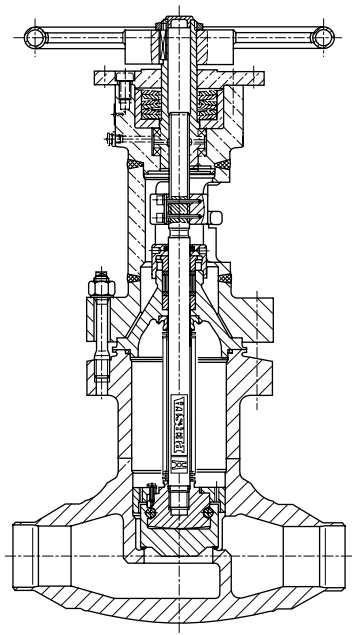

**Monobloc-Z-valve**

