

 STRAINERS zSTRA













Body material	Nominal pressure	Nominal diameter	Max. temperature
F Cast steel	E 40 bar	DN 15-200	450°C
I Stainless steel	E 40 bar	DN 15-200	400°C

 correspond to the pressure equipment directive 2014/68/UE marking CE for DN≥32

**FEATURES**

- screen made of stainless steel (from DN 50 with reinforced ring, from DN 150 with supporting basket)
- compact settlement
- environment-friendly
- cleaning of screen without disassembling
- face-to-face dimension according to EN 558 series 1
- flanges drilled according to EN 1092-1
- but welded ends according to EN 12627

**APPLICATION**

industries						
	INDUSTRY	SHIPBUILDING INDUSTRY	HEATING	POWER ENGINEERING		
media						
	GLYCOL	INDUSTRIAL WATER	DIATHERMIC OIL	STEAM	COMPRESSED AIR	NEUTRAL FLUIDS

Data given can be changed without notice.

Edition 01/2018

FIG.827

MATERIALS, DIMENSIONS

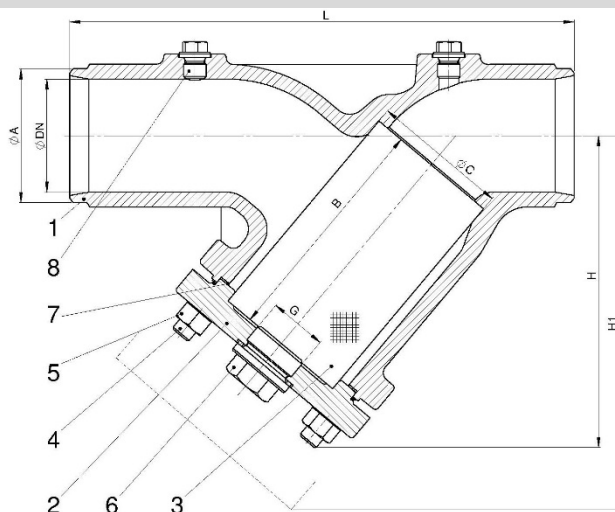

	Material kadłuba	F	I
1	Body	GP240GH 1.0619	GX5CrNiMo19-11-2
2	Cover	GP240GH 1.0619	GX5CrNiMo19-11-2
3	Screen	X5CrNi 18-10 1.4301	
4	Studs	25CrMo4	A4-70
5	Hexagon nut	25CrMo4	A4-70
6	Draing plug	C35E	A2
7	Cover gasket	CrNiSt- Graphite	
8	Plug *	C35E	A2
<b>Max. temperature</b>		<b>450°C</b>	<b>400°C</b>

\* plugs on client's request

DN	(mm)	15	20	25	32	40	50	65	80	100	125	150	200
	(inch)	1/2	3/4	1	1 1/4	1 1/2	2	2 1/2	3	4	5	6	8
L	(mm)	130	150	160	180	200	230	290	310	350	400	480	600
A	(mm)	22	28	35	44	50	62	78	91	117	144	172	223
B	(mm)	56	68	82	98	114	119	134	149	169	199	224	284
C	(mm)	23	28	36	42	50	61,5	78,5	89,5	109,5	137,5	160	210
H	(mm)	90	100	115	135	150	160	180	215	240	280	330	405
H1	(mm)	135	160	180	215	240	250	285	330	395	455	525	650
G	(inch)	G 3/8	G 3/8	G 3/4	G 3/4	G 1	G1	G1	G1	G 1 1/2	G1 1/2	G1 1/2	G1 1/2
Kvs	(m³/h)	6,3	11,2	14,7	23,7	37,7	57,9	101,5	147,4	209,6	326,2	403	707
Weight	(kg)	1,6	2,4	2,8	3,9	5,7	7,5	10,8	14,5	23	33,5	51	105,5

Data given can be changed without notice.

Edition 01/2018

**PRESSURE-TEMPERATURE RATINGS**

Acc. EN 1092-1	PN		-40°±<-10°C	-10°C±50°C	100°C	150°C	200°C	250°C	300°C	350°C	400°C	450°C
GP240GH	40	bar	30	40	37,1	35,2	33,3	30,4	27,6	25,7	23,8	13,1
Acc. g EN 1092-1			-60°±<-10°C	-10°C±100°C	150°C	200°C	250°C	300°C	350°C	400°C	450°C	
G-X5CrNiMo19-11-2	40	bar		40	40	36,3	33,7	31,8	29,7	28,5	27,4	---

**SCREENS**

Screen	Type	DN	Mesh size	Mesh/cm2	Execution
Standard	F45	10-50	1,0	45	50
	F28	65-80	1,25	28	49
	F15	100-400	1,6	15	43
Other performance	screen cartridges F100 (0,6), F200 (0,5), F300 (0,4), F400 (0,32), F600 (0,25)				

\* type with magnetic cartridge on client's request

**HYDRAULIC CHARACTERISTIC**

DN	15	20	25	32	40	50	65	80	100	125	150	200
Screen	Kv sr. [m <sup>3</sup> /h]											
Standard	6,3	11,2	14,7	23,7	37,7	57,9	101,5	147,4	209,6	326,2	403,0	707,0
F100 (0,63)	6,2	9,6	14,2	23,1	36,6	53,7	95,1	137,1	206,4	268,8	401,4	706,7
F200 (0,50)	6,2	9,5	14,1	23,0	35,6	53,0	92,7	133,4	202,7	314,3	462,3	811,0
F300 (0,40)	6,1	9,3	13,5	22,1	33,4	49,8	86,0	121,2	183,5	284,3	420,3	738,3
F400 (0,32)	6,0	9,1	13,2	21,7	33,4	48,5	82,9	115,9	173,7	268,8	401,4	706,7
F600 (0,25)	6,0	9,1	13,0	21,7	33,3	48,4	82,6	115,9	173,1	266,8	397,9	701,2

Data given can be changed without notice.

Edition 01/2018

FIG.827

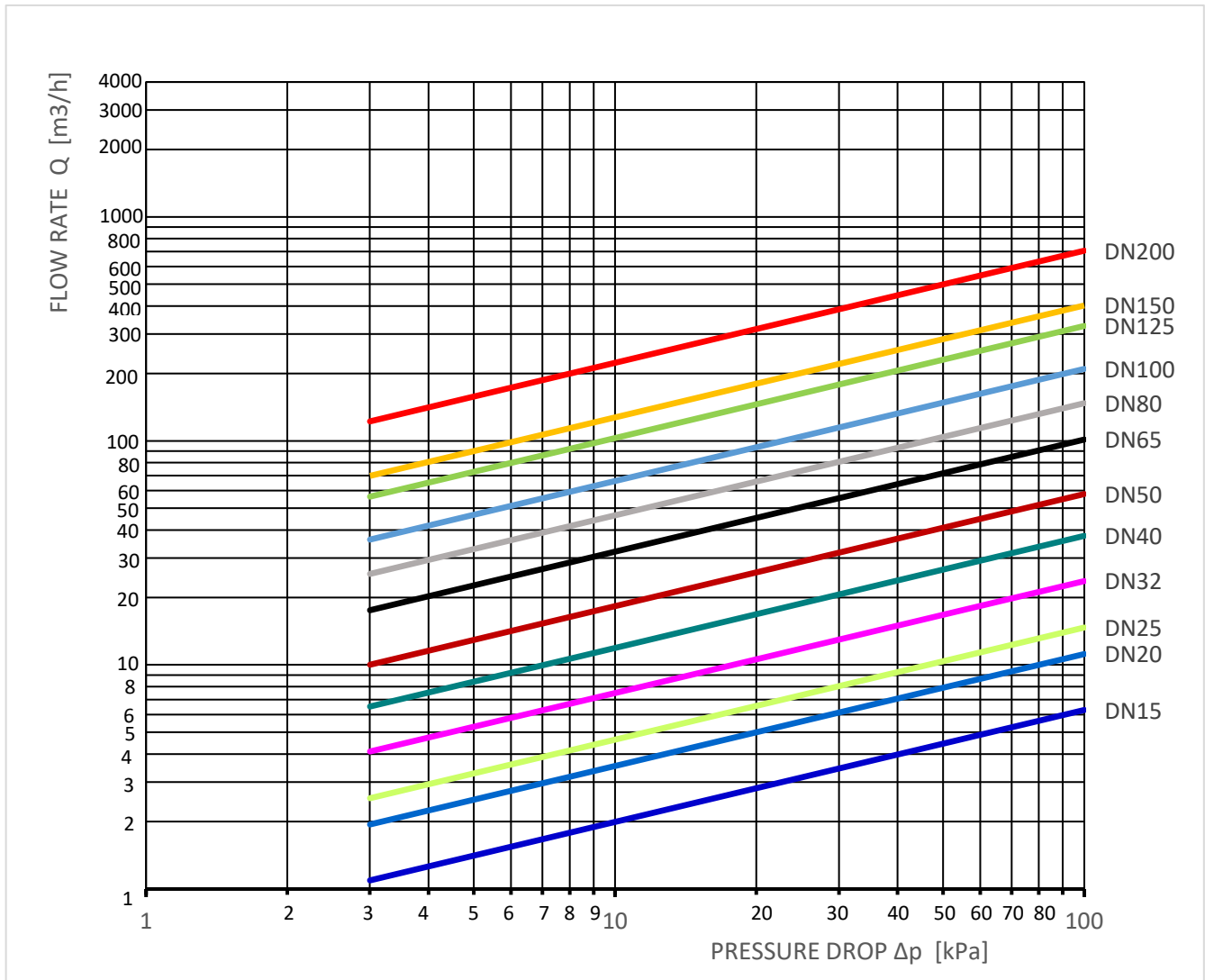

Data given can be changed without notice.

Edition 01/2018

**WZF-100 FILTER POLLUTION INDICATOR**

WZF 100 - filter pollution indicator, operating on the principle of measuring pressure difference before and after the filter. The measurement is carried out by a magnetic field sensor that measures a displacement of a magnet placed on the sensor's piston.

The indicator is available in three versions:

- version with battery power supply,
- version with battery power supply and output and power supply from 4-20 mA current loop,
- version with battery power supply and a WiFi communication module.

All versions of the indicators are powered by a battery that allows to use the indicator in places without mains power. In the case of a version equipped with a 4-20 mA output, it is possible to permanently supply the sensor from the current loop. In indicators equipped with a WiFi module, external power supply is necessary to use the module.

Display of the pollution status is carried out for all versions by means of a display made up of LEDs, two green ones, two orange ones and one red one. In addition, a blue LED indicates power on.

#### Sensor parameters

Ambient temperature from -20°C to 70°C

Medium temperature 120 °C

Medium - cold and hot water, neutral agents

Differential pressure measurement range from 0 bar to 1,2 bar

Maximum static pressure 16 bar

External and current loop power supply 16÷32 V DC

Degree of protection IP 66



**WZF-100 FILTER POLLUTION INDICATOR**

Remember that the direction of flow on the indicator and filter should be the same. To mount the indicator, order a filter drilled and plugged with G1/4" plugs.

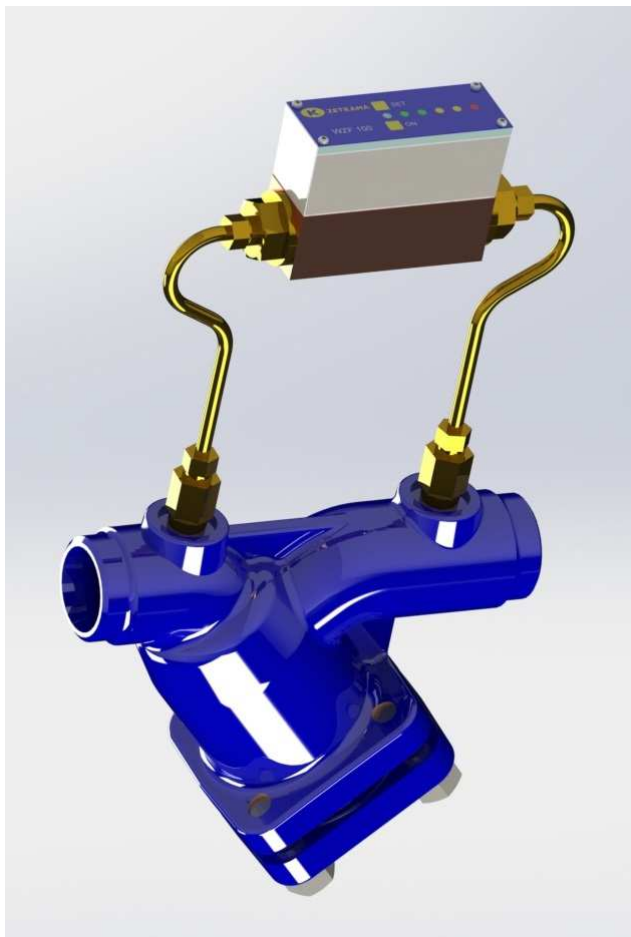

The method of attachment on the filter.

Available accessories:

1. Allen tube for each DN diameter
2. zG1/4"/ wM10 x 1 reducer

More data in the user manual.

FIG.827



TYPE

Figure	Body material	Nominal diameter	Nominal pressure	Type
827	F Cast steel GP240GH	15-50 mm	E 40 bar	50 mesh 1,00 mm, 45 mesh/cm <sup>2</sup>
		65-80 mm	E 40 bar	49 mesh 1,25 mm, 28 mesh/cm <sup>2</sup>
		100-200 mm	E 40 bar	43 mesh 1,60 mm, 15 mesh/cm <sup>2</sup>
		15-200 mm	E 40 bar	44 mesh 0,63 mm, 100 mesh/cm <sup>2</sup>
		15-200 mm	E 40 bar	45 mesh 0,50 mm, 200 mesh/cm <sup>2</sup>
		15-200 mm	E 40 bar	46 mesh 0,40 mm, 300 mesh/cm <sup>2</sup>
		15-200 mm	E 40 bar	47 mesh 0,32 mm, 400 mesh/cm <sup>2</sup>
		15-200 mm	E 40 bar	48 mesh 0,25 mm, 600 mesh/cm <sup>2</sup>
827	I Stainless steel G-X5CrNiMo19-11-2	15-50 mm	E 40 bar	50 mesh 1,00 mm, 45 mesh/cm <sup>2</sup>
		65-80 mm	E 40 bar	49 mesh 1,25 mm, 28 mesh/cm <sup>2</sup>
		100-200 mm	E 40 bar	43 mesh 1,60 mm, 15 mesh/cm <sup>2</sup>
		15-200 mm	E 40 bar	44 mesh 0,63 mm, 100 mesh/cm <sup>2</sup>
		15-200 mm	E 40 bar	45 mesh 0,50 mm, 200 mesh/cm <sup>2</sup>
		15-200 mm	E 40 bar	46 mesh 0,40 mm, 300 mesh/cm <sup>2</sup>
		15-200 mm	E 40 bar	47 mesh 0,32 mm, 400 mesh/cm <sup>2</sup>
		15-200 mm	E 40 bar	48 mesh 0,25 mm, 600 mesh/cm <sup>2</sup>

Data given can be changed without notice.

Edition 01/2018

ZETKAMA Sp. z o.o.  
Ul. 3 Maja 12  
PL 57-410 Ścinawka Średnia

Tel. +48 74 8652 193  
Tel. +48 74 8652 111  
Fax +48 74 8652 199

E-mail [export@zetskama.com.pl](mailto:export@zetskama.com.pl)  
[www.zetskama.com](http://www.zetskama.com)

FIG.827

**ORDERING**

Figure	Body material	Nominal diameter	Nominal pressure	Type
827	F Cast steel GP240GH	15-50 mm	E 40 bar	50 mesh 1,00 mm, 45 mesh/cm <sup>2</sup>

Order example acc. index

827 F 050 E 50

Strainer, weldedends, form Y-tape	827				
Cast steel GP240GH		F			
Nominal diameter (mm)			050		
Nominal pressure PN 40				E	
Mesh 1,00 mm, 45 mesh/cm <sup>2</sup>					50

Data given can be changed without notice.

Edition 01/2018