

BUTTERFLY VALVE zBUT



Body material	Nominal pressure	Nominal diameter	Max. temperature
J Aluminum	B 10 bar	50-100	210°C*
	A 6 bar	125-200	
	J 2,5bar	250-600	

\* max. temperature depends on the used materials



correspond to the pressure equipment directive 2014/68/UE

**FEATURES**

- high tightness class - A acc. to EN - 12266 – 1
- compact settlement
- environment-friendly
- tests acc. to EN - 12266 - 1
- face-to-face dimension according to EN 558 series 20
- Epoxy RAAL 5002 150 µm
- sealing EPDM/ NBR/ FLUCAST/ SILICONE/ VITON/ HYPALON/ EPICHLOROHYDRIN/ NEOPREN/ BUTYL
- discs NODULAR CAST IRON/ STAINLESS STEEL/ ALUMINIUM/ BRONZE/ ALU-BRONZE/ CAST STEEL/ DUPLEX/ SUPERDUPLEX

**APPLICATION \***

\* not all of the applications are suitable for all of the executions

industries					
	INDUSTRY	SHIPBUILDING INDUSTRY	HEATING	REFRIGERATION AND AIR CONDITIONING	FOOD INDUSTRY
media					
	GLYCOL	INDUSTRIAL WATER	DIATHERMIC OIL	COMPRESSED AIR	NEUTRAL FLUIDS

Data given can be changed without notice.

Edition 01/2018

**MATERIALS, DIMENSIONS**

DN32-500

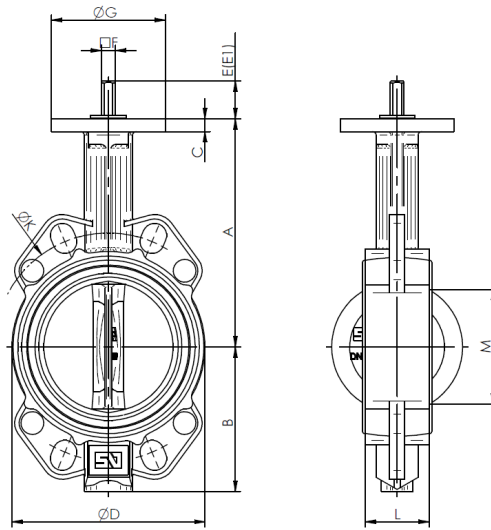

Body material		J		
Type		06	36	A6
1	Body	EN-AC 44100 G-AISI12		
2	Disc*	1.4408		
3	Seat**	EPDM		
4	Stem	1.4005		
steering		free shaft	catch lever	gear box
Max. temperature		110°C		

\* other disc materials on request  
 \*\* other seat materials on request

DN	50	65	80	100	125	150	200	250	300	350	400	450	500	600
A (mm)	140	154	160	180	197	211	240	283	308	339	380	381	433	494
B (mm)	80	91	100	114	130	145	175	210	240	263	308	340	380	440
C (mm)	10	10	10	10	10	10	10	14	14	16	18	20	20	24
D (mm)	97	113	128	153	182	207	262	324	376	422	480	536	593	690
E (mm)	30	30	30	30	33	33	33	30	30	31	31	38	38	80
F (mm)	11	11	11	11	14	14	17	22	22	22	27	36	36	Ø60
G (mm)	90	90	90	90	90	90	90	130	130	160	160	190	210	210
K (mm) (PN10)	125	145	160	180	210	240	295	350	400	460	515	565	620	725
M (mm)	29	46	65	90	112	139	191	241	290	338	387	434	478	570
L (mm)	43	46	46	52	56	56	60	68	78	78	102	114	127	154
ISO	F-07	F-07	F-07	F-07	F-07	F-07	F-07	F-10	F-10	F-10	F-12	F-14	F-14	F-16
Weight (kg)	1,2	1,6	1,9	2,3	3,4	4,2	7,3	12,1	18,1	23,0	36,1	54,6	72,9	114

Data given can be changed without notice.

Edition 01/2018

ZETKAMA Sp. z o.o.  
 Ul. 3 Maja 12  
 PL 57-410 Ścinawka Średnia

Tel. +48 74 8652 193  
 Tel. +48 74 8652 111  
 Fax +48 74 8652 199

E-mail export@zetkama.com.pl  
 www.zetkama.com

FIG.496

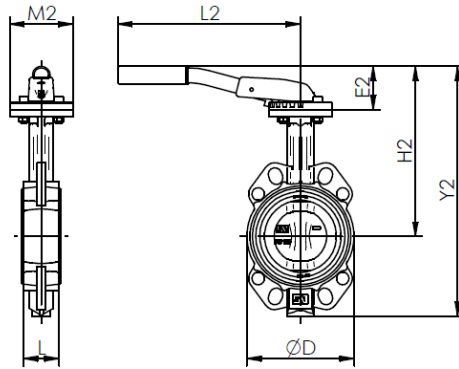

N	50	65	80	100	125	150	200
D (mm)	96	112	128	152	182	207	262
L (mm)	43	46	46	52	56	56	60
E 2 (mm)	49	49	60	60	75	75	75
H 2 (mm)	189	203	220	240	272	286	315
Y 2 (mm)	269	294	320	354	402	431	490
L 2 (mm)	220	220	260	260	315	315	315
M 2(mm)	90	90	90	90	90	90	90
Weight (kg)	16	2,1	24	2,9	4,0	4,8	7,9

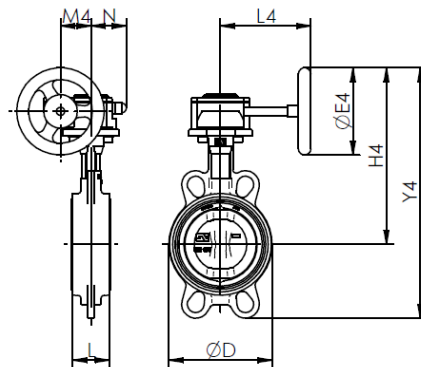

DN	D	L	E4	H4	Y4	L4	M4	N	Weight (kg)
50	96	43	125	228	308	129	43,5	50,5	2,4
65	112	46	125	242	333	129	43,5	50,5	2,9
80	128	46	125	248	348	129	43,5	50,5	3,2
100	152	52	125	268	382	129	43,5	50,5	3,6
125	182	56	160	302	432	135	43,5	50,5	4,9
150	207	56	160	316	461	135	43,5	50,5	5,6
200	262	60	200	370	545	152	52,5	59	9,9
250	324	68	250	442	652	222	61,5	70,5	15,7
300	376	78	250	468	708	222	61,5	70,5	21,0
350	422	78	250	498	762	222	61,5	70,5	26,7
400	480	102	300	572	880	277	68,8	72,5	44,5
450	536	114	400	630	970	321	96,5	91,5	74,0
500	593	127	400	682	1062	321	98,5	91,5	92,0
600	690	154	500	798	1239	408	138	140	149,0

Data given can be changed without notice.

Edition 01/2018

ZETKAMA Sp. z o.o.  
 Ul. 3 Maja 12  
 PL 57-410 Ścinawka Średnia

Tel. +48 74 8652 193  
 Tel. +48 74 8652 111  
 Fax +48 74 8652 199

E-mail [export@zetskama.com.pl](mailto:export@zetskama.com.pl)  
[www.zetskama.com](http://www.zetskama.com)

KV [m<sup>3</sup>/h] DEPENDING OF ANGLE OPENING DISC

DN	90°	80°	70°	60°	50°	40°	30°	25°
50	112	90	60	45	23	14	7,7	5
65	172	138	90	70	36	22	12,9	8,6
80	258	207	138	110	54	33	19	13
100	474	410	260	200	103	63	36	24
125	970	860	540	420	215	133	76	52
150	1680	1420	890	690	353	215	146	125
200	2800	2350	1510	1120	603	360	215	146
250	4310	3700	3190	1850	990	580	336	224
300	6465	5215	3490	2670	1380	860	475	327
350	8620	6980	4395	3535	1896	1120	645	430
400	10775	9310	5600	4395	2285	1465	775	560
450	15086	12700	7930	6120	3190	1980	1077	775
500	18965	15085	9900	7500	3965	2415	1380	970
600	24137	20700	14225	10130	5260	3275	1895	1293

## OPERATING TORQUE IN NM TO CLOSE THE VALVES DEPENDING ΔP (BAR)

DN	3 bar	6 bar	10 bar
50	5	7	13
65	15	16	20
80	17	20	23
100	22	29	42
125	39	46	72
150	48	75	90
200	90	120	140
250	126	210	270
300	161	270	390
350	245	300	500
400	520	600	700
450	590	1120	1450
500	840	1390	1800
600	1000	2200	3450

Data given can be changed without notice.

Edition 01/2018

**PART'S MATERIALS**

## Disc

Material	Standard	Application
Stainless steel	1.4308	Chemical products/ nourishing products
Stainless steel	1.4408	Demineralized water/ chemical products/ nourishing products
Stainless steel	1.4404	Chemical and nourishing products/ sea water/ demineralized water
Aluminium	En-AC-44100	Cold water/ air
Bronze tin	CuSn10-C	Sea water
Bronze-aluminium	CuAl10Fe5Ni5-C	Sea water
Cast steel	GP240GH	Water/ gas
Nodular cast iron	EN-GJS-400-15 5.3106	Hot water / air/ gas
Nodular cast iron + EPDM	EN-GJS-400-15 + EPDM 5.3106	Powdery products/ pneumatic transport/ sea water
Duplex	1.4517	Chemical products
Superduplex	1.4469	Sea water/ corrosive atmospheres

## Seat

Material	Application	Temperature range	
EPDM ( Ethylene propylene)	Water/ sea water/ weak acids and basis	-40°C	+110°C
EPDM HT (EDM high temp.)	Heating without steam water	+80°C	+130°C
NBR (nitrile)	Mineral oils/ vegetables oils/ greases	-40°C	+90°C
Flucast AB/P	Abrasive powdered products	-10°C	+90°C
Flucast AB/E	Oxygenated solvents ketones esters with abrasion	-20°C	+95°C
Flucast AB/N	Mineral oils/ vegetables oils/ greases/ abrasives	-10°C	+100°C
Silicone	Air and hot water without steam	-60°C	+200°C
Food silicone	Nourishing and milky products	-60°C	+200°C
Steam silicone	steam	-60°C	+140°C
Viton	Acids/ high temperature	-15°C	+210°C
Biodisel Viton	Biodiesel	-5°C	+210°C
Viton GF Gasoline	Oxygenate gasoline	-5°C	+210°C
Hypalon	Water/ diluted bases	-25°C	+120°C
Epichlorohydrin	Brine systems	-40°C	+125°C
Neoprene	Sea water	-25°C	+80°C
Butyl	Gas	-10°C	+95°C
Flucast extreme	Water / steam / acids	-5°C	+200°C

Data given can be changed without notice.

Edition 01/2018

**TYPE**

Figure	Body material	Nominal diameter	Nominal pressure	Type
496	J Aluminum EN-AC 44100	50-100 mm	B 10 bar	disc - stainless steel; EPDM sealing; catch lever <b>36</b>
		125-200 mm	A 6 bar	disc - stainless steel; EPDM sealing; catch lever <b>36</b>
		250-600 mm	J 2,5 bar	disc - stainless steel; EPDM sealing; catch lever <b>36</b>
		50-100 mm	B 10 bar	disc - stainless steel; EPDM sealing; , bare shaft - for the actuator <b>06</b>
		125-200 mm	A 6 bar	disc - stainless steel; EPDM sealing; , bare shaft - for the actuator <b>06</b>
		250-600 mm	J 2,5 bar	disc - stainless steel; EPDM sealing; , bare shaft - for the actuator <b>06</b>
		50-100 mm	B 10 bar	disc - cast stainless steel, gearbox, EPDM sealing <b>A6</b>
		125-200 mm	A 6bar	disc - cast stainless steel, gearbox, EPDM sealing <b>A6</b>
		250-600 mm	J 2,5 bar	disc - cast stainless steel, gearbox, EPDM sealing <b>A6</b>

**ORDERING**

Figure	Body material	Nominal diameter	Nominal pressure	Type
496	J Aluminum EN-AC 44100	50-100 mm	B 10 bar	disc - stainless steel; EPDM sealing; catch lever <b>36</b>

**Order example acc. index**

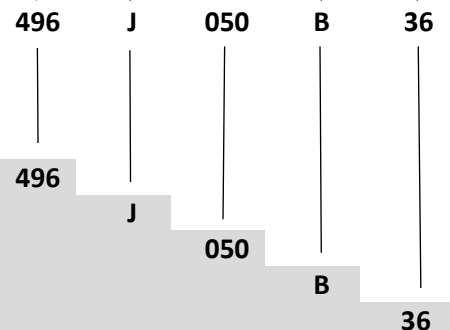

Butterfly valve, ends wafer type, form straight  
 Aluminum EN-AC 44100  
 Nominal diameter (mm)  
 Nominal pressure PN 10  
 Disc - stainless steel; EPDM sealing; catch lever

Data given can be changed without notice.

Edition 01/2018