

BALL VALVE zBAL



Body material	Nominal pressure	Nominal diameter	Max. temperature
A Grey cast iron	C 16 bar	DN 15-200	150°C
	B 10 bar	DN 250	100°C
B Nodular cast iron	C 16 bar	DN 15-150	150°C



correspond to the pressure equipment directive 2014/68/UE marking CE for DN≥32

FEATURES

- high tightness (leakproofness class - A acc. to EN -12266 - 1)
- compact settlement
- environment-friendly
- tests acc. to EN - 12266 - 1
- flanges drilled according to EN 1092-2
- face-to-face dimension according to EN 558 series 14 (DN 15-150)
- face-to-face dimension according to EN 558 series 15 (DN 200-250)

APPLICATION

industries	INDUSTRY	SHIPBUILDING INDUSTRY	HEATING	
media	GLYCOL	INDUSTRIAL WATER	COMPRESSED AIR	NEUTRAL FLUIDS

Data given can be changed without notice.

Edition 01/2018

MATERIALS, DIMENSIONS

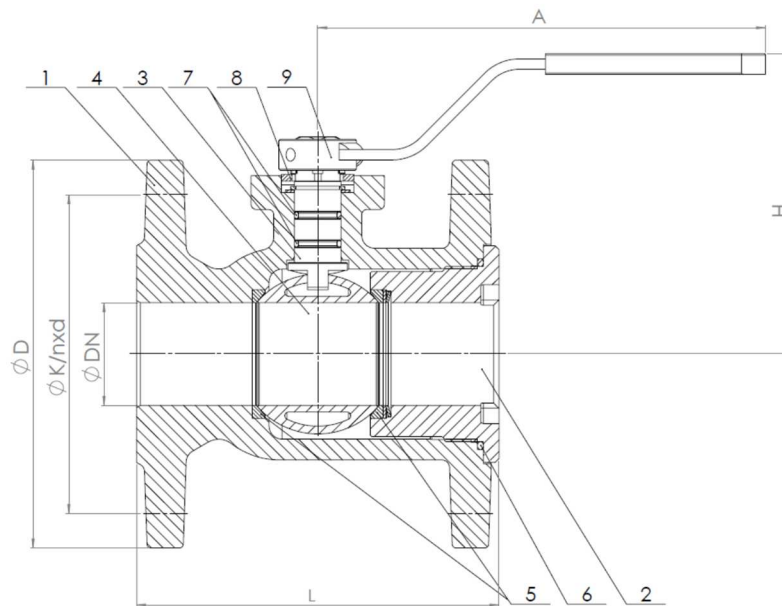

	Body material	A			B	
		02	05	09	05	06
1	Body	EN – GJL-250 5.1301 (ex. JL 1040)			EN – GJS-400 – 15 5.3106 (ex. JS 1030)	
2	Screw plug	EN – GJL-250 5.1301 (ex. JL 1040)				
3	Stem	CuZn39Pb3		X20Cr13 1.4021	CuZn39Pb3	AISI 304 1.4301
4	Ball	CuZn39Pb3	AISI 304 1.4301		AISI 304 1.4301	CuZn39Pb3
5	Ball seat	PTFE				
6	Sealing ring	EPDM*				
7	Sealing ring	FKM	NBR*	EPDM*	NBR*	
8	Opening limiter	Carbon steel + zinc				
9	Lever	Carbon steel + zinc				
Max. temperature		150°C**				

* upon special request – FKM

DN	15	20	25	32	40	50	65	80	100	125	150	200	250	
L (mm)	115	120	125	130	140	150	170	180	190	200	210	400	450	
A (mm)	172	172	185	185	250	250	300	300	525	625	625	1000	1350	
H (mm)	78	85	80	90	116	125	150	160	180	245	260	320	-----	
K _{vs} (m ³ /h)	8,4	14,6	23,0	38,8	61,3	96,7	164,2	244,9	392,6	597,9	875,2	1656,5	2616,6	
Weight (kg)	A	2,2	2,6	3,3	4,9	6,5	8,2	11,9	16,5	25,0	36,9	45,0	93,0	180,0
	B	2,6	3,3	4,2	5,8	7,5	9,0	10,5	15,5	18,5	28,0	38,5	-----	-----

Data given can be changed without notice.

Edition 01/2018

ZETKAMA Sp. z o.o.
Ul. 3 Maja 12
PL 57-410 Ścinawka Średnia

Tel. +48 74 8652 193
Tel. +48 74 8652 111
Fax +48 74 8652 199

E-mail export@zetskama.com.pl
www.zetskama.com

FIG.565

DN 200

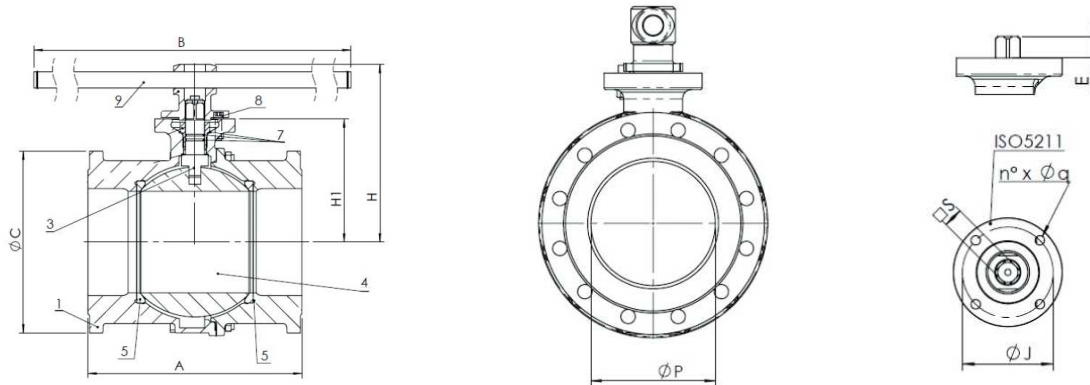

DN 250

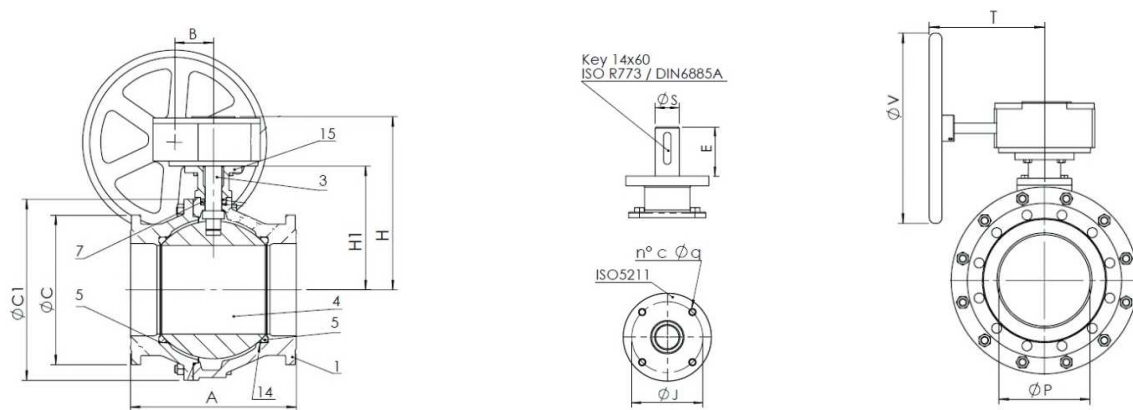

DN	200	250
P (mm)	190	240
A (mm)	400	450
H (mm)	320	448
H1 (mm)	230	335
B (mm)	1000	101
G (mm)	340	405
C1 (mm)	-	490
V (mm)	-	500
T (mm)	-	284
ISO5311	F12	F12
J (mm)	125	125
n x ϕq	4 x 13	4 x 13
E (mm)	92	92
S (mm)	$\phi 27$	$\phi 45$
Weight (kg)	93	180

Data given can be changed without notice.

Edition 01/2018

FIG.565

BALL VALVE WITH PNEUMATIC ACTUATOR

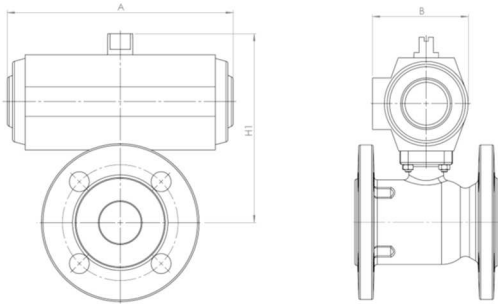

DN	15	20	25	32	40	50	65	80	100	125	150
A (mm)	133	133	176	176	205	205	214	214	267	355	355
B* (mm)	60	60	71	71	94	94	122	122	146	172	172
H1** (mm)	134	140	158	167	182	189	241	308	335	410	430
Weight (kg)	3,0	3,4	4,4	6,0	7,9	8,9	11,8	16,0	33,9	52,2	61,5

* REVO's actuator

Additional equipment:

- control valve
- location transmitter

BALL VALVE WITH ELECTRIC ACTUATOR

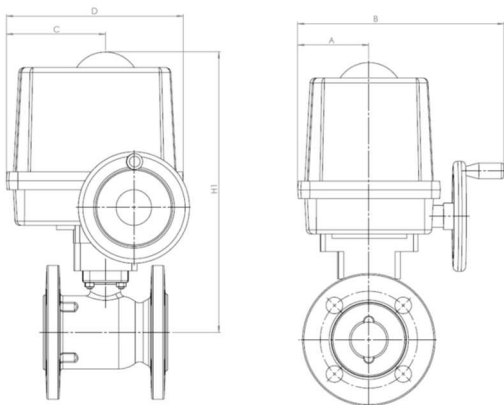

DN	15	20	25	32	40	50	65	80	100	125	150
A (mm)	86	86	79	79	79	79	93	93	109	109	109
B (mm)	60	60	71	71	94	94	122	122	146	172	172
C (mm)	96	96	86	86	86	86	96	96	111	111	111
D (mm)	196	196	196	196	196	196	227	227	278	278	278
H1 (mm)	134	140	158	167	182	189	241	308	335	410	430
Weight (kg)	3,0	3,4	4,4	6,0	7,9	8,9	11,8	16,0	33,9	52,2	61,5

Standard equipment:

- 230 V engine
- two road limit switches
- two torque switches
- regulated end stops
- hand wheel
- mechanical location indicator
- IP67 protection rating

Additional equipment:

- 24 VDC, 24 VAC and 400 VAC engines
- 1 or 2 location transmitters x 100 Ohm
- location transmitter 4-20 mA
- additional road limit/ torque switches
- electronic location regulator
- heater
- local control
- IP68 protection rating

Another on customer's request.

Data given can be changed without notice.

Edition 01/2018

PRESSURE-TEMPERATURE RATINGS

	PN		-10°C÷120°C	150°C
EN-GJL-250	10	bar	10	----
EN-GJL-250	16		16	14,4
EN-GJS-400-15	16		16	15,5

FLANGE DIMENSIONS ACC. PN-EN 1092-1/-2

DN		15	20	25	32	40	50	65	80	100	125	150	200	250
PN 10	D (mm)	95	105	115	140	150	165	185	200	220	250	285	340	395
	K (mm)	65	75	85	100	110	125	145	160	180	210	240	295	350
	nxd (mm)	4x14	4x14	4x14	4x19	4x19	4x19	4x19	8x19	8x19	8x19	8x23	8x23	12x23
PN16	D (mm)	95	105	115	140	150	165	185	200	220	250	285	340	405
	K (mm)	65	75	85	100	110	125	145	160	180	210	240	295	350
	nxd (mm)	4x14	4x14	4x14	4x19	4x19	4x19	4x19	8x19	8x19	8x19	8x23	12x23	12x28

TYPE

Figure	Body material	Nominal diameter	Nominal pressure	Type
565	A Grey cast iron EN-GJL-250	15-200 mm	C 16 bar	ball AISI 304; ball seat PTFE; stem- stainless steel 09
		200 mm	C 16 bar	ball AISI 304; o-ring NBR; stem- brass 05
		200 mm	C 16 bar	brass ball; o-ring FKM; stem- brass 02
		250 mm	B 10 bar	ball AISI 304; o-ring NBR; stem- brass 05
		250 mm	B 10 bar	brass ball; o-ring FKM; stem- brass 02
565	B Nodular cast iron EN-GJS-400-15	15-150 mm	C 16 bar	brass ball; ball seat PTFE; stem- stainless steel 06
				ball AISI 304; o-ring NBR; stem- brass 05

Data given can be changed without notice.

Edition 01/2018

ORDERING

Figure	Body material	Nominal diameter	Nominal pressure	Type
565	A Grey cast iron EN-GJL-250	15-200 mm	C 16 bar	09 ball AISI 304; o-ring PTFE; stem- stainless steel

Order example acc. index

565 A 050 C 09

Ball valve, ends flanged, form straight
 Grey cast iron EN-GJL-250
 Nominal diameter (mm)
 Nominal pressure PN 16
 Ball AISI 304; o-ring PTFE; stem- stainless steel

565 A 050 C 09

Data given can be changed without notice.

Edition 01/2018