

EMERSON™
KEYSTONE

Resilient seated flange type butterfly valves Size 65mm to 1,800mm (2½" to 72")

Features & Benefits

- The concentric disc offers bi-directional service and allows high Cv values with its symmetric shape
- Primary seal is formed by the disc hub and stem top, the seat contact exceeds the pressure rating of the valve
- Secondary stem seal is suitable for high pressure and is self-adjusting
- Disc hub edge are rounded and hand polished to provide full concentric sealing without seat obstruction to flow, combined with maximum seat life
- Replacement seat isolates the stem and body parts from the stream and also serves as the flange gasket
- Moulded-in O-ring provides positive flange sealing and eliminates the need for gasket
- Double flanged body design specified according to JIS F7480
- Heavy duty top bushing absorbs side thrust and torque loads
- Stainless steel disc screws allow quick and easy disassembly
- Factory testing of every valve at full rating ensures 100% tight shut-off
- Type approved by various major shipping class



General Applications

The Figure V11 is a double flanged type, fully rubber lined valves for the marine industry. Applications are mainly for :

- Shipside valves
- Ballast valves

Technical Data

Pressure	: 5/10kg/cm ² (75/150 psi)
Temperature	: -40°C to 120°C (-40°F to 248°F)
Size	: 65mm to 1,800mm (2½" to 72")
Flange Accommodation	: JIS 5K/10K PN 6/10

Butterfly Valve Figure V11

Valve Dimensions

65mm to 500mm

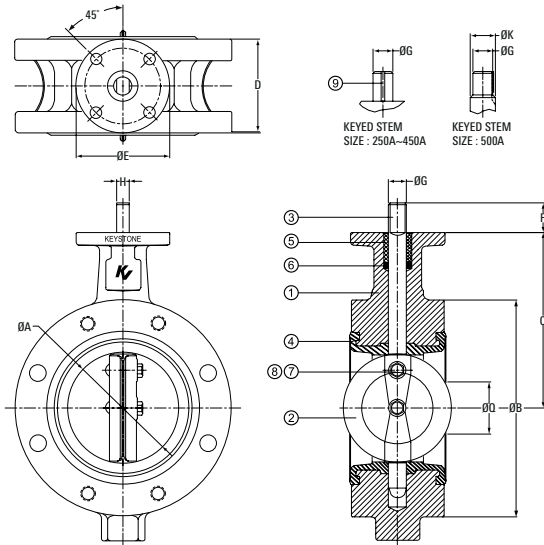

Parts list

Item	Component
1	Body
2	Disc
3	Stem
4	Seat
5	Bushing
6	Packing
7	Disc Screw
8	O-ring
9	Key

550mm to 1,000mm

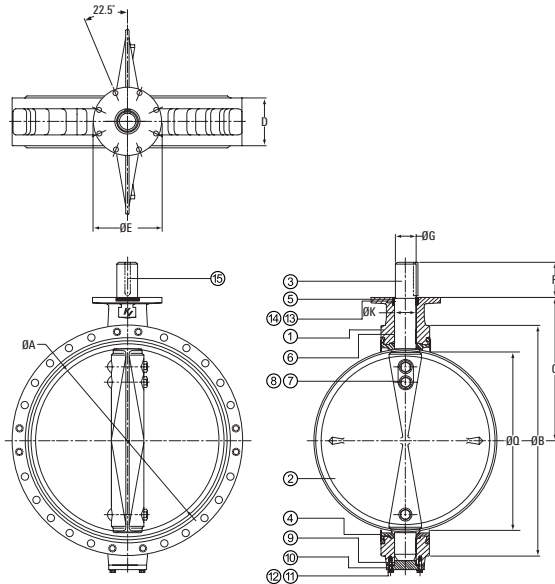

Parts list

Item	Component
1	Body
2	Disc
3	Stem
4	Seat
5	Packing Holder
6	Bushing
7	Disc Screw
8	O-ring
9	O-ring
10	Bottom Cover
11	Bottom Cover Screw
12	Spring Washer
13	O-ring
14	O-ring
15	Key

1,200mm to 1,800mm

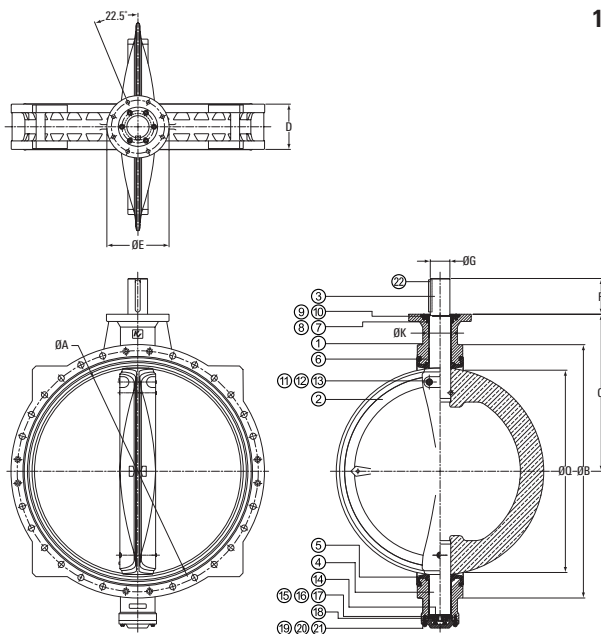

Parts list

Item	Component
1	Body
2	Disc
3	Upper Stem
4	Lower Stem
5	Seat
6	Bearing
7	Packing Holder
8	O-ring
9	Holder Cover
10	Cover Bolt
11	Taper Pin
12	Nut
13	O-ring
14	Thrust Ring
15	Axial Positioning Ring
16	Stop Bolt
17	Position Bolt
18	Locking Ring
19	Bottom Cover Screw
20	Wrench Bolt & Washer
21	O-ring
22	Key

Butterfly Valve Figure V11

Valve Dimensions

Dimensions (mm)																		
Valve Size		øA	øB		C	D	øE	F	øG	H	øK	øQ	Top Plate Data			Weight (kg)		
(Inch)	(mm)		JIS 5K	JIS 10K									B.C.D.	Hole No.	Hole Dia.	JIS 5K	JIS 10K	
2½	65	64	155	175	152	40	102	32	14.30	9.5	-	55	82.6	4	11.0	8	9	
3	80	76	180	185	159	60	102	32	14.30	9.5	-	53	82.6	4	11.0	12	13	
4	100	92	200	210	178	60	102	32	15.90	11.1	-	75	82.6	4	11.0	15	17	
5	125	119	235	250	191	100	102	32	19.10	12.7	-	69	82.6	4	11.0	17	20	
6	150	143	265	280	203	100	102	32	19.10	12.7	-	106	82.6	4	11.0	25	30	
8	200	190	320	330	241	100	152	32	22.20	15.9	-	168	127.0	4	14.3	33	40	
10	250	242	385	400	273	110	152	51	28.60	-	-	222	127.0	4	14.3	46	55	
12	300	290	430	445	300	110	152	51	28.60	-	-	275	127.0	4	14.3	55	66	
14	350	329	480	490	320	120	152	76	34.90	-	-	313	127.0	4	14.3	75	90	
16	400	382	540	560	353	130	152	76	41.30	-	-	366	127.0	4	14.3	94	113	
18	450	438	605	620	390	150	203	108	47.60	-	-	419	165.0	4	21.0	127	152	
20	500	471	655	675	415	160	203	108	47.60	-	54.0	450	165.0	4	21.0	156	187	
22	550	520	720	745	460	170	203	90	60.00	-	65.0	506	165.0	4	21.0	202	242	
22*	550	520	720	745	460	170	203	108	47.60	-	65.0	506	165.0	4	21.0	202	242	
24	600	570	770	795	485	170	203	90	60.00	-	65.0	559	165.0	4	21.0	230	276	
24*	600	570	770	795	485	170	203	108	47.60	-	65.0	559	210.0	4	21.0	230	276	
26	650	625	825	845	519	170	254	90	60.00	-	70.0	616	210.0	4	21.0	262	314	
28	700	676	875	905	545	180	254	90	60.00	-	70.0	666	210.0	4	21.0	297	356	
30	750	717	945	970	585	190	254	117	75.00	-	80.0	705	210.0	4	21.0	373	448	
32	800	768	995	1,020	615	200	254	117	75.00	-	80.0	754	210.0	4	21.0	432	518	
34	850	818	1,045	1,070	650	210	300	150	90.00	-	-	803	254.0	8	18.0	503	604	
36	900	865	1,095	1,120	691	230	300	150	90.00	-	95.0	851	254.0	8	18.0	630	756	
40	1,000	962	1,195	1,235	744	250	360	176	107.95	-	110.0	945	317.5	8	20.0	777	932	
48	1,200	1,162	1,420	1,465	880	254	350	200	110.00	-	120.0	1,150	298.0	8	21.0	1,242	1,294	
56	1,400	1,370	-	1,675	1,000	279	415	210	130.00	-	140.0	1,358	356.0	8	31.0	-	1,510	
60	1,500	1,462	1,730	1,795	1,070	279	415	250	142.00	-	150.0	1,452	356.0	8	31.0	1,840	1,924	
64	1,600	1,571	-	1,915	1,140	318	415	263	150.00	-	160.0	1,556	356.0	8	31.0	-	2,248	
72	1,800	1,764	-	2,115	1,260	356	475	263	170.00	-	180.0	1,745	406.0	8	37.0	-	2,853	

*Use for manual operator.

※ 56", 64", 72" : ISO 2084 NP10

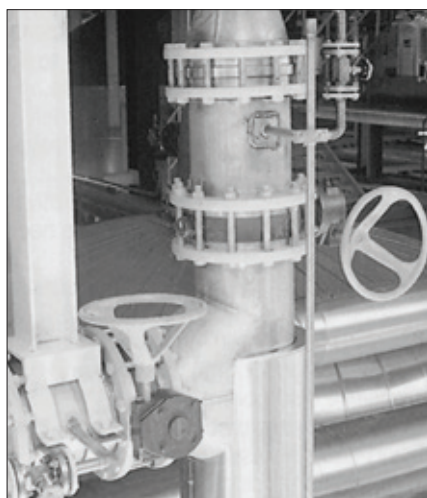

Notes

- 1 Valve size shown is for 125mm, 1,000mm, 1,200mm.
- 2 "Q" is the disc chordal dimension at face of valve for disc clearance into pipe fitting or equipment.
- 3 The valve dimensions are for reference only. For detailed information, please consult factory.
- 4 Valve dimensions shown are the JIS standard.

Actuator Selection

Actuator	Figure	Remark
Handle	F401	Leverlock
Gear	F420 to F430	Range of heavy duty gear operators available
Pneumatic	F79U	Double acting and spring return rack and pinion designs
Gear & Pneumatic	F453/79U	Dec clutchable gear unit provides manual override for the Keystone pneumatic actuator
Electric	EPI ₂	Compact electric actuators

Butterfly Valve Figure V11

Valve Data / Material Selection

K_v values

Disc opening	Valve Size in mm																								
	65	80	100	125	150	200	250	300	350	400	450	500	550	600	650	700	750	800	900	1,000	1,200	1,400	1,500	1,600	1,800
10"	2.6	3.4	5	9	15	21	33	49	65	86	110	130	160	190	225	260	300	340	433	540	830	1,400	1,700	2,320	3,130
20"	10.0	14.0	25	38	52	95	155	220	290	380	490	610	750	860	990	1,120	1,290	1,460	2,249	2,770	4,190	7,080	8,600	11,780	15,850
30"	22.0	33.0	54	86	120	220	340	510	660	860	1,120	1,380	1,680	1,980	2,320	2,670	3,050	3,440	4,498	5,830	8,820	14,900	18,110	24,800	33,360
40"	38.0	57.0	95	160	220	380	610	860	1,200	1,550	1,980	2,490	2,960	3,440	4,130	4,820	5,510	6,200	7,872	9,610	14,440	24,390	29,660	40,600	54,620
50"	60.0	95.0	150	240	340	590	950	1,460	1,890	2,410	3,100	3,960	4,730	5,500	6,530	7,570	8,510	9,460	12,975	15,480	23,150	39,100	47,550	65,090	87,570
60"	95.0	150.0	240	390	550	950	1,550	2,320	2,920	3,870	4,990	6,190	7,390	8,600	9,900	11,200	13,350	15,500	19,895	24,910	37,380	63,120	76,760	105,080	141,360
70"	160.0	240.0	400	640	950	1,550	2,580	3,780	4,820	6,360	8,260	10,300	12,450	14,600	16,750	18,900	22,350	25,800	32,870	42,120	63,070	106,510	129,520	177,300	238,510
80"	250.0	370.0	620	950	1,380	2,410	3,960	5,850	7,740	9,460	12,900	15,500	18,950	22,400	26,700	31,000	34,400	37,800	51,900	62,280	93,390	157,710	191,790	262,540	363,180
90"	280.0	430.0	710	1,120	1,630	2,840	4,640	6,880	8,600	11,200	15,500	18,900	22,350	25,800	30,100	34,400	39,550	44,700	60,550	73,510	110,260	186,200	226,430	309,960	416,980

Notes

Rated K_v=the volume of water in m³/hr that will pass through a given valve opening at a pressure drop of 1 bar C_v=1.156 K_v

Material Selection

Part name	Material	ASME Standard	KS Standard	Optional Material
Body	Carbon Steel	A216 Grade WCB	D4101 SC480	Ductile Iron
	Cast Iron	A126 Class B	D4301 GC200/GC250	
Disc	304 Stainless Steel	A351 Grade CF8	D4103 SSC13A	
	316 Stainless Steel	A351 Grade CF8M	D4103 SSC14A	
	Aluminium Bronze	B148-C95200	D6024 CAC701	
Stem	304 Stainless Steel	A276 Type 304	D3706 STS304	17-4PH Stainless Steel
	316 Stainless Steel	A276 Type 316	D3706 STS316	
Seat	NBR			
	EPDM			
Disc Screw	304 Stainless Steel	A276 Type 304	D3706 STS304	17-4PH Stainless Steel
	316 Stainless Steel	A276 Type 316	D3706 STS316	
	Alloy 2205			
Bushing	Acetal			
Bearing	PTFE on Steel			
Packing	NBR			Fluoroelastomer
Packing Holder	Bronze	B61		304/316 Nitride
Bottom Cover	Steel	A36		316 Stainless Steel

Notes

Other materials or combination of materials are available on request.

Model Coding System

Example :	Valve size (mm)	Figure number	Trim code	
	065	V11	T065	
Trim Code	Body	Disc	Stem	Seat
T065	Cast Iron	Al Bronze	304SS	NBR
T062	Cast Iron	Al Bronze	304SS	EPDM
T329	Cast Iron	304SS	304SS	NBR
T331	Cast Iron	304SS	304SS	EPDM
T098	Cast Iron	316SS	316SS	NBR
T089	Ductile Iron	Al Bronze	304SS	NBR
T087	Ductile Iron	Al Bronze	304SS	EPDM
T093	Ductile Iron	304SS	304SS	NBR
T045	Ductile Iron	304SS	304SS	EPDM
T123	Cast Steel	Al Bronze	304SS	NBR
T423	Cast Steel	Al Bronze	304SS	EPDM
T097	Cast Steel	304SS	304SS	NBR
T105	Cast Steel	304SS	304SS	EPDM