



KTM SERIES NB / MB THREE-WAY BALL VALVES 2-SEATS (L-PORT) AND 4-SEATS (L AND T-PORT)

A single KTM 3-way ball valve replaces several 2-way valves, saving valuable space and simplifying piping



GENERAL APPLICATION

Diverting or mixing fluids.

TECHNICAL DATA

2 seats (L-port)

Model: Series NB
Full bore: DN 40 - 350 (NPS 1½ - 14)
Reduced bore: DN 125 - 350 (NPS 5 - 14)
Pressure rating: ASME Class 150, 300, 600
JIS 10K, 20K, 40K
Temperature: -29°C to 270°C (-20°F - 518°F)
(Option: up to 500°C/932°F)

4 seats (L and T-port)

Model: Series MB
Full bore: DN 15 - 300 (NPS ½ - 12)
Reduced bore: DN 125 - 350 (NPS 5 - 14)
Pressure rating: ASME Class 150, 300, 600
JIS 10K, 20K, 40K
Temperature: -29°C to 150°C (-20°F - 302°F)

FEATURES

- Positive alignment of body.
- Blow-out proof stem for safety.
- Sphericity tolerance of the ball is unsurpassed.
- Multiple layers of adjustable PTFE chevron packing rings for standard model enable excellent fugitive emission control.
- Positive position indication.
- Locking device capable.
- Heavy duty body construction.
- Machined ISO 5211 top mounting flange.
- Live load springs keep constant force on stem-seal packing, ensuring seal integrity and extended valve life.
- Dual shaft bearings for high cycle life operation.
- Higher C_v values and less cost for diverting which can be normally done with multiple installation of valves.

2 seats feature

- EB1 compatible, co-polymer E-seat as standard.
- Machined firesafe lip for metal touch to ball in case of fire. It also eliminates possibility of seat deformation.
- Lower operating torque, easing operation and reducing actuator cost.

4 seats feature

- Equipped with 4 seats so that each port can be used as an inlet.
- Available with L-port and T-port for variety of applications.
- E-seat as standard for MB1 Class 150 (MB11 and MB21).

KTM SERIES NB / MB THREE-WAY BALL VALVES

2-SEATS (L-PORT) AND 4-SEATS (L AND T-PORT)

2-SEATS (L-PORT) SERIES NB - FULL BORE / SERIES NB - REDUCED BORE

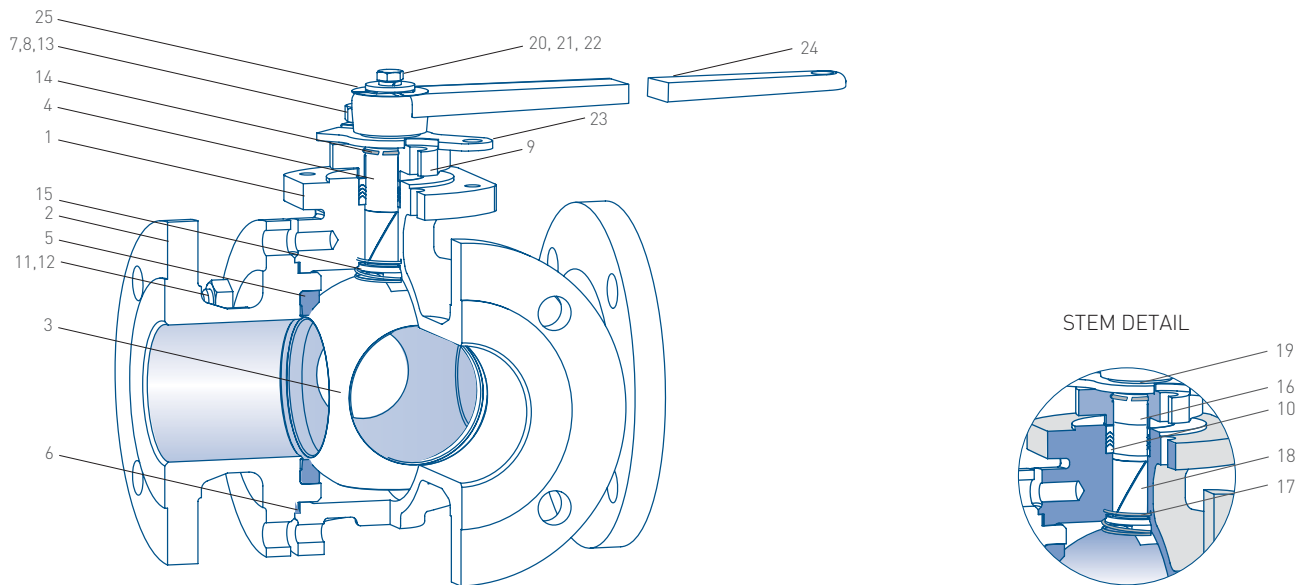

Note: The illustration shows body construction of 3-way ball valve, Series NB11 in DN 80 (NPS 3)

PARTS LIST

No.	Description	Material
1	Body	CF8M, CF8, or WCB
2	Body cap	CF8M, CF8, or WCB
3	Ball	CF8M or CF8
4	Shaft	316 S/S or 304 S/S
5	Seat	E-seat as standard (T or G seat for options)
6	Gasket	R-PTFE
7	Gland bolt	A193 (G) B8
8	Washer	316 S/S
9	Gland flange	CF8
10	Gland packing	PTFE
11	Stud	A193 (G) B8 or A193 (G) B7
12	Nut	A194 (G) 8 or A194 (G) 2H
13	Live loading spring	304 S/S
14	Anti-static spring	316L S/S
15	Anti-static spring	316L S/S
16	Gland bearing	PTFE
17	Thrust bearing	PTFE
18	Shaft bearing	R-PTFE
19	Snap ring	304 S/S
20	Spring washer	304 S/S
21	Bolt	304 S/S
22	Washer	304 S/S
23	Stopper	304 S/S
24	Handle	Carbon steel
25	Indicator	304 S/S

OPTIONS

- NACE MR-01-75
- Grating seat for high temp. service (Series NB, 2 seats)
- Extension bonnet for low temp. service (Series NB, 2 seats)
- CE Marking PED 97 / 23 / EC
- Special tests
 - X-ray (RT)
 - Liquid penetrant (PT)
 - Positive Material Identification (PMI)

KTM SERIES NB / MB THREE-WAY BALL VALVES

2-SEATS (L-PORT) AND 4-SEATS (L AND T-PORT) - METRIC

2-SEATS (L-PORT) SERIES NB - FULL BORE / SERIES NB - REDUCED BORE

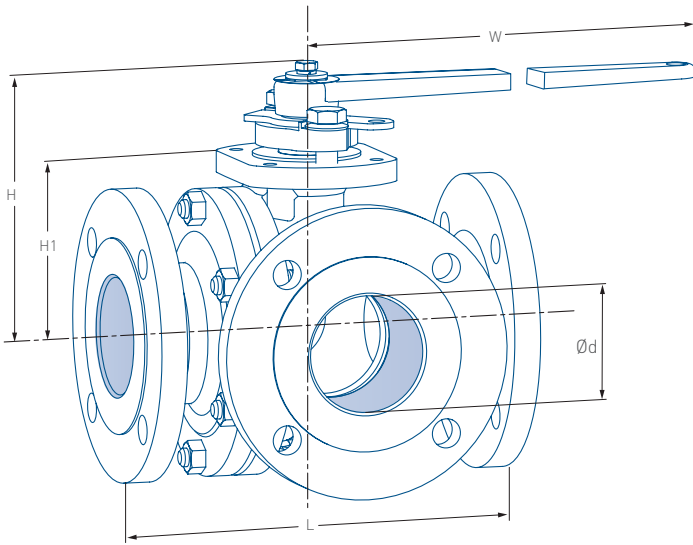

ASME CLASS 150 / JIS 10K DIMENSIONS - NB1 (NB11 AND NB21)

DN	Full bore - NB1 (NB11)					Reduced bore - NB1 (NB21)					
	Ød	L	H	W	H1	Ød	Ødo	L	H	W	H1
40	38	210	103	230	69	-	-	-	-	-	-
50	51	220	113	230	79	-	-	-	-	-	-
65	64	250	155	400	104	-	-	-	-	-	-
80	76	260	164	400	113	-	-	-	-	-	-
100	102	330	189	715	138	-	-	-	-	-	-
125	127	370	311	1140	168	102	127	370	189	715	138
150	152	430	331	1140	188	127	152	430	311	1140	168
200	203	540	414	1510	248	152	203	540	331	1140	188
250	254	670	-	-	328	203	254	670	414	1510	248
300	305	762	-	-	387	254	305	762	-	-	328
350	337	864	-	-	450	305	337	864	-	-	387

ASME CLASS 300 / JIS 20K DIMENSIONS - NB1 (NB12 AND NB22)

DN	Full bore - NB1 (NB12)					Reduced bore - NB1 (NB22)					
	Ød	L	H	W	H1	Ød	Ødo	L	H	W	H1
40	38	220	103	230	69	-	-	-	-	-	-
50	51	240	113	230	79	-	-	-	-	-	-
65	64	270	155	400	104	-	-	-	-	-	-
80	76	290	164	400	113	-	-	-	-	-	-
100	102	350	189	715	138	-	-	-	-	-	-
125	127	410	311	1140	168	102	127	410	189	715	138
150	152	460	331	1140	188	127	152	460	311	1140	168
200	203	570	414	1510	248	152	203	570	331	1140	188
250	254	720	-	-	328	203	254	720	414	1510	248
300	305	860	-	-	387	254	305	860	331	-	188

ASME CLASS 600 / JIS 40K DIMENSIONS - NB1

DN	Full bore - NB1					
	Ød	L		H	W	H1
		RF	RJ			
20	19	190	190	121	160	71
25	25	216	216	139	230	82
40	38	254	254	154	230	97
50	51	330	333	191	400	128
80	76	356	359	255	715	148
100	102	432	435	332.5	1140	190
150	152	559	562	-	-	262

NOTE
Ødo = bore opening diameter on reduced bore valves

KTM SERIES NB / MB THREE-WAY BALL VALVES

2-SEATS (L-PORT) AND 4-SEATS (L AND T-PORT) - IMPERIAL

2-SEATS (L-PORT) SERIES NB - FULL BORE / SERIES NB - REDUCED BORE

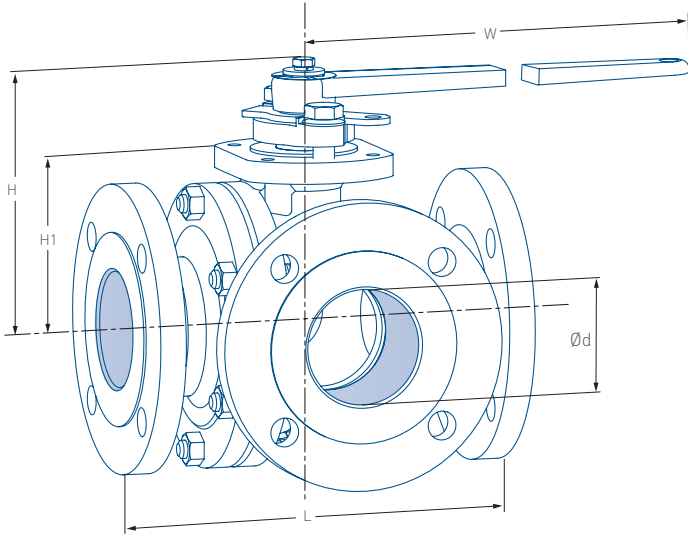

ASME CLASS 150 / JIS 10K DIMENSIONS - NB1 (NB11 AND NB21)

NPS	Full bore - NB1 (NB11)					Reduced bore - NB1 (NB21)					
	Ød	L	H	W	H1	Ød	Ødo	L	H	W	H1
1½	1.50	8.27	4.06	9.06	2.72	-	-	-	-	-	-
2	2.01	8.66	4.45	9.06	3.11	-	-	-	-	-	-
2½	2.52	9.84	6.10	15.75	4.09	-	-	-	-	-	-
3	2.99	10.24	6.46	15.75	4.45	-	-	-	-	-	-
4	4.02	12.99	7.44	28.15	5.43	-	-	-	-	-	-
5	5.00	14.57	12.24	44.88	6.61	4.02	5.00	14.57	7.44	28.15	5.43
6	5.98	16.93	13.03	44.88	7.40	5.00	5.98	16.93	12.24	44.88	6.61
8	7.99	21.26	16.30	59.45	9.76	5.98	7.99	21.26	13.03	44.88	7.40
10	10.00	26.38	-	-	12.91	7.99	10.00	26.38	16.30	59.45	9.76
12	12.01	30.00	-	-	15.24	10.00	12.01	30.00	-	-	12.91
14	13.27	34.02	-	-	17.72	12.01	13.27	34.02	-	-	15.24

ASME CLASS 300 / JIS 20K DIMENSIONS - NB1 (NB12 AND NB22)

NPS	Full bore - NB1 (NB12)					Reduced bore - NB1 (NB22)					
	Ød	L	H	W	H1	Ød	Ødo	L	H	W	H1
1½	1.50	8.66	4.06	9.06	2.72	-	-	-	-	-	-
2	2.01	9.45	4.45	9.06	3.11	-	-	-	-	-	-
2½	2.52	10.63	6.10	15.75	4.09	-	-	-	-	-	-
3	2.99	11.42	6.46	15.75	4.45	-	-	-	-	-	-
4	4.02	13.78	7.44	28.15	5.43	-	-	-	-	-	-
5	5.00	16.14	12.24	44.88	6.61	4.02	5.00	16.14	7.44	28.15	5.43
6	5.98	18.11	13.03	44.88	7.40	5.00	5.98	18.11	12.24	44.88	6.61
8	7.99	22.44	16.30	59.45	9.76	5.98	7.99	22.44	13.03	44.88	7.40
10	10.00	28.35	-	-	12.91	7.99	10.00	28.35	16.30	59.45	9.76
12	12.01	33.86	-	-	15.24	10.00	12.01	33.86	13.03	-	7.40

ASME CLASS 600 / JIS 40K DIMENSIONS - NB1

NPS	Full bore - NB1						
	Ød	L				W	H1
		RF	RJ	H			
¾	0.75	7.48	7.48	4.76	6.30	2.80	
1	0.98	8.50	8.50	5.47	9.06	3.23	
1½	1.50	10.00	10.00	6.06	9.06	3.82	
2	2.01	12.99	13.11	7.52	15.75	5.04	
3	2.99	14.02	14.13	10.04	28.15	5.83	
4	4.02	17.01	17.13	13.09	44.88	7.48	
6	5.98	22.01	22.13	-	-	10.31	

NOTE

Ødo = bore opening diameter on reduced bore valves

KTM SERIES NB / MB THREE-WAY BALL VALVES

2-SEATS (L-PORT) AND 4-SEATS (L AND T-PORT)

4-SEATS (L AND T-PORT) SERIES MB - FULL BORE / SERIES MB - REDUCED BORE

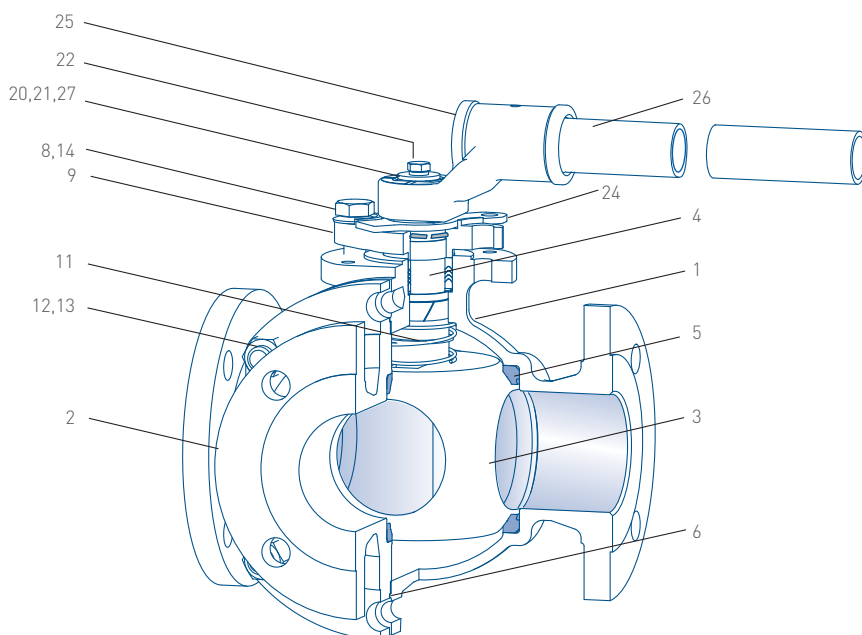

STEM DETAIL

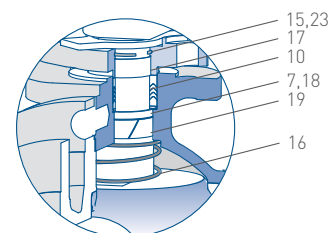

Note: The illustration shows body construction of 3-way ball valve, Series MB11 in DN 80 (NPS 3)

PARTS LIST

No.	Description	Material
1	Body	CF8M, CF8, or WCB
2	Body cap	CF8M, CF8, or WCB
3	Ball	CF8M or CF8
4	Stem	316 S/S or 304 S/S
5	Seat	E-seat as standard for MB11 H-seat as standard for MB12
6	Gasket	PTFE or R-PTFE
7	Thrust washer	316 S/S
8	Gland bolt	A193 (G) B8
9	Gland flange	CF8
10	Gland packing	PTFE
11	Snap ring	304 S/S
12	Stud	A193 (G) B8 or A193 (G) B7
13	Nut	A194 (G) 8 or A194 (G) 2H
14	Live loading spring	304 S/S
15	Anti-static spring	316L S/S
16	Anti-static spring	316L S/S
17	Gland bearing	PTFE
18	Thrust bearing	PTFE
19	Shaft bearing	R-PTFE
20	Washer	304 S/S
21	Spring washer	304 S/S
22	Bolt	304 S/S
23	Snap ring	304 S/S
24	Stopper	304 S/S
25	Handle head	Carbon steel
26	Handle/pipe	Carbon steel
27	Indicator	304 S/S

OPTIONS

- NACE MR-01-75
- CE Marking PED 97 / 23 / EC
- Special tests
 - X-ray (RT)
 - Liquid penetrant (PT)
 - Positive Material Identification (PMI)

NOTE

Please consult your local Emerson representative for 4 seats ASME Class 300 valves (MB12 and MB22)

KTM SERIES NB / MB THREE-WAY BALL VALVES

2-SEATS (L-PORT) AND 4-SEATS (L AND T-PORT) - METRIC

4 - SEATS (L AND T - PORT) SERIES MB - FULL BORE / SERIES MB - REDUCED BORE

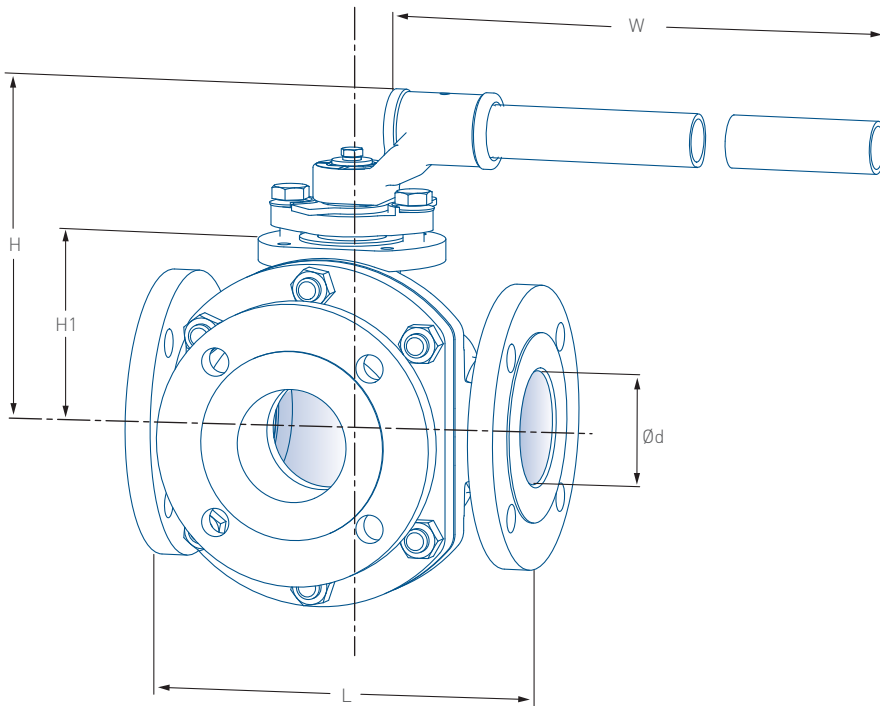

ASME CLASS 150 / JIS 10K DIMENSIONS - MB1 (MB11 AND MB21)

DN	Full bore - MB1 (MB11)					Reduced bore - MB1 (MB21)					
	Ød	L	H	W	H1	Ød	Ødo	L	H	W	H1
15	13	140	94	160	46	-	-	-	-	-	-
20	19	150	108	230	52	-	-	-	-	-	-
25	25	160	110	230	54.5	-	-	-	-	-	-
40	38	210	158	400	97	-	-	-	-	-	-
50	51	220	164	400	103	-	-	-	-	-	-
65	64	250	215	715	113	-	-	-	-	-	-
80	76	260	224	715	121.5	-	-	-	-	-	-
100	102	330	304	1050	161	-	-	-	-	-	-
125	127	430	327	1050	184	102	127	370	304	1050	161
150	152	510	314	-	223	127	152	430	327	1050	184
200	203	580	-	-	281.5	152	203	500	-	-	223
250	254	740	-	-	395	-	-	-	-	-	-
300	305	991	-	-	477	305	337	991	-	-	477

ASME CLASS 600 / JIS 40K DIMENSIONS - MB1

DN	Full bore - MB1					
	Ød	L		H	H1	W
		RF	RJ			
15	13	300	298.5	124	67	230
20	19	300	300	124	67	230
25	25	306	306	124	67	230
40	38	410	410	234	129	715

NOTE

Ødo = bore opening diameter on reduced bore valves

Please consult your local Emerson representative for 4 seats ASME Class 300 valves (MB12 and MB22)

KTM SERIES NB / MB THREE-WAY BALL VALVES

2-SEATS (L-PORT) AND 4-SEATS (L AND T-PORT) - IMPERIAL

4 - SEATS (L AND T - PORT) SERIES MB FULL BORE / SERIES MB REDUCED BORE

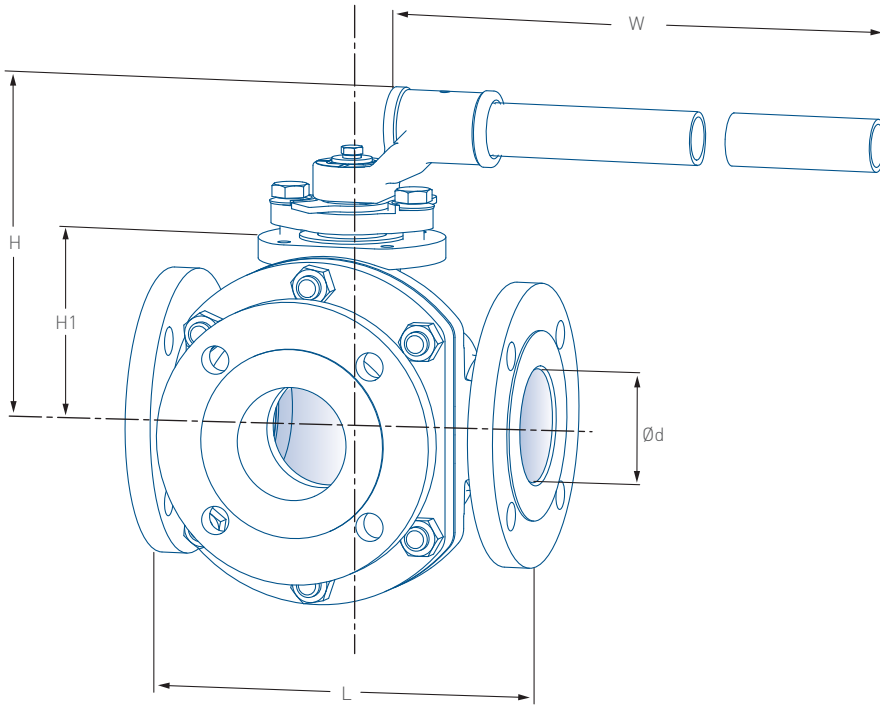

ASME CLASS 150 / JIS 10K DIMENSIONS - MB1 (MB11 AND MB21)

NPS	Full bore - MB1 (MB11)					Reduced bore - MB1 (MB21)					
	Ød	L	H	W	H1	Ød	Ødo	L	H	W	H1
1/2	0.51	5.51	3.70	6.30	1.81	-	-	-	-	-	-
3/4	0.75	5.91	4.25	9.06	2.05	-	-	-	-	-	-
1	0.98	6.30	4.33	9.06	2.15	-	-	-	-	-	-
1 1/2	1.50	8.27	6.22	15.75	3.82	-	-	-	-	-	-
2	2.01	8.66	6.46	15.75	4.06	-	-	-	-	-	-
2 1/2	2.52	9.84	8.46	28.15	4.45	-	-	-	-	-	-
3	2.99	10.24	8.82	28.15	4.78	-	-	-	-	-	-
4	4.02	12.99	11.97	41.34	6.34	-	-	-	-	-	-
5	5.00	16.93	12.87	41.34	7.24	4.02	5.00	14.57	11.97	41.34	6.34
6	5.98	20.08	12.36	-	8.78	5.00	5.98	16.93	12.87	41.34	7.24
8	7.99	22.83	-	-	11.08	5.98	7.99	19.69	-	-	8.78
10	10.00	29.13	-	-	15.55	-	-	-	-	-	-
12	12.01	39.02	-	-	18.78	12.01	13.27	39.02	-	-	18.78

ASME CLASS 600 / JIS 40K DIMENSIONS - MB1

NPS	Full bore - MB1					
	Ød	L		H	H1	W
		RF	RJ			
1/2	0.51	11.81	11.75	4.88	2.64	9.06
3/4	0.75	11.81	11.81	4.88	2.64	9.06
1	0.98	12.05	12.05	4.88	2.64	9.06
1 1/2	1.50	16.14	16.14	9.21	5.08	28.15

NOTE

Ødo = bore opening diameter on reduced bore valves

Please consult your local Emerson representative for 4 seats ASME Class 300 valves (MB12 and MB22)

KTM SERIES NB / MB THREE-WAY BALL VALVES

2-SEATS (L-PORT) AND 4-SEATS (L AND T-PORT) - METRIC

PRESSURE-TEMPERATURE RATINGS

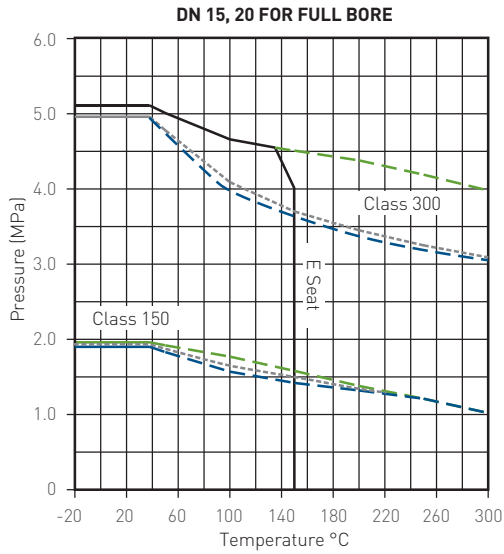

LEGEND:

Dashed lines indicate body ratings.

- WCB
- CF8M
- CF8
- 4-seats - Upper limit 150°C (302°F)

NOTE

E seat is PTFE/PFA copolymer seat
 Seat ratings for Gratiite seated valves are identical to ASME body ratings
 Please consult your local Emerson representative for 4 seats ASME Class 300 valves (MB12 and MB22)

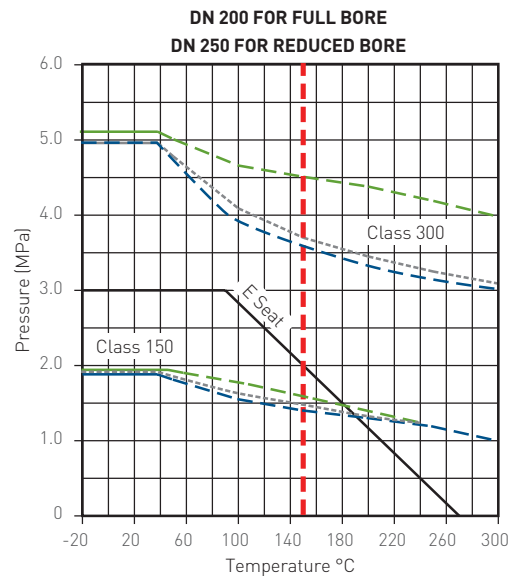
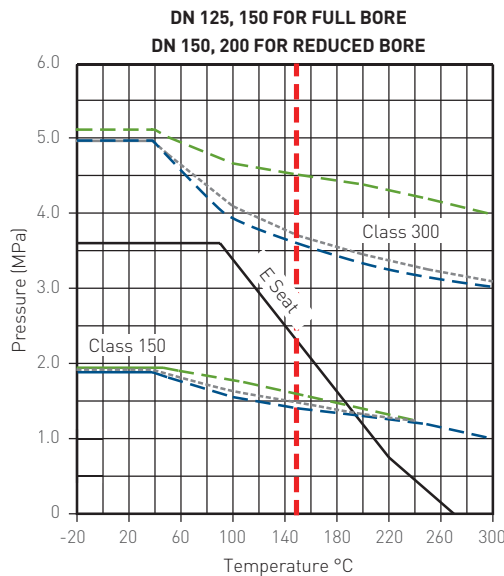
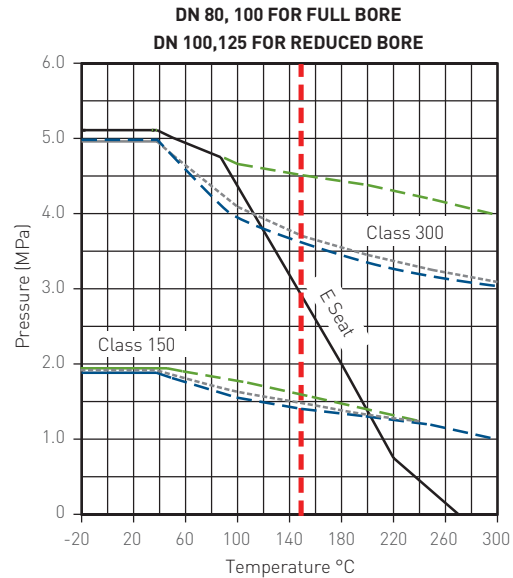
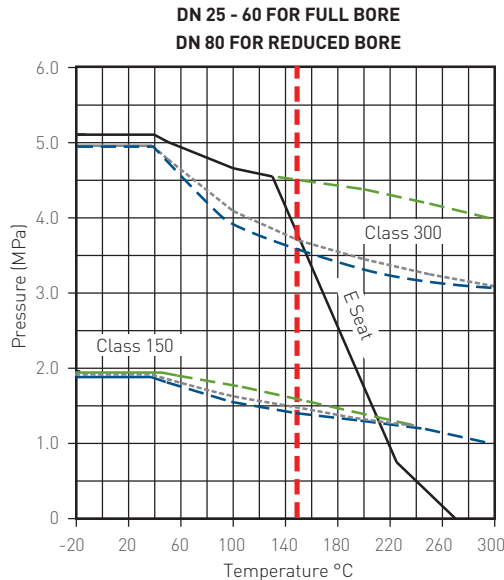

KTM SERIES NB / MB THREE-WAY BALL VALVES

2-SEATS (L-PORT) AND 4-SEATS (L AND T-PORT) - IMPERIAL

PRESSURE-TEMPERATURE RATINGS

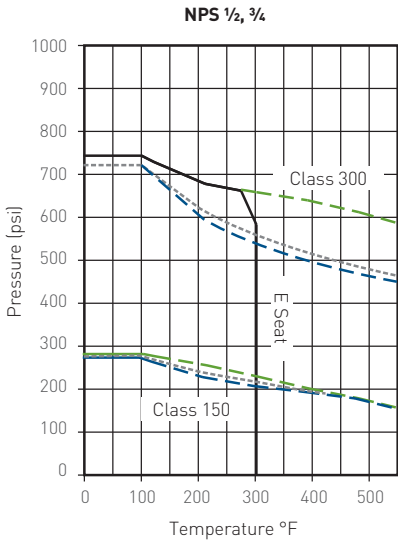

LEGEND:

Dashed lines indicate body ratings.

- WCB
- CF8M
- CF8
- 4-seats - Upper limit 302°F

NOTE

E seat is PTFE/PFA copolymer seat
 Seat ratings for Gratiite seated valves are identical to ASME body ratings
 Please consult your local Emerson representative for 4 seats ASME Class 300 valves (MB12 and MB22)

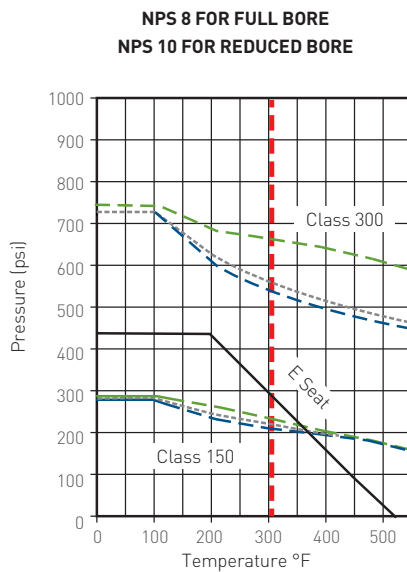
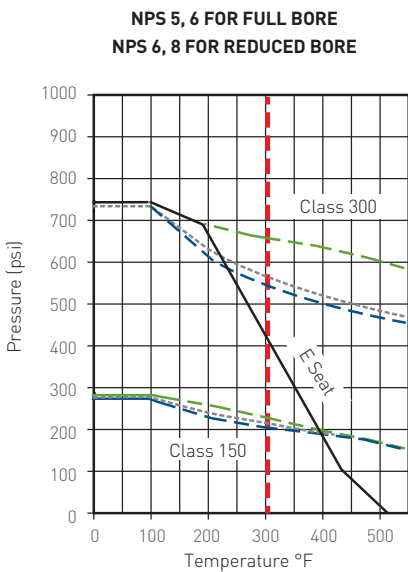
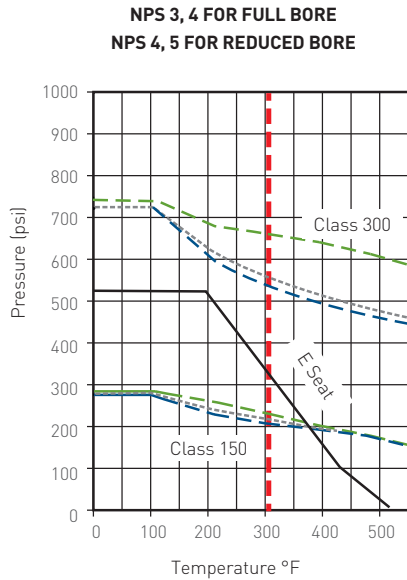
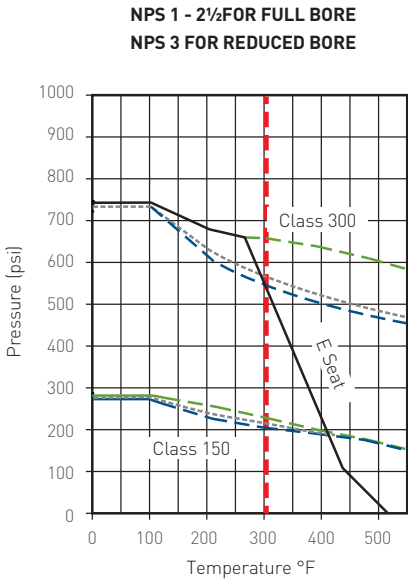

KTM SERIES NB / MB THREE-WAY BALL VALVES

2-SEATS (L-PORT) AND 4-SEATS (L AND T-PORT)

OPERATION FORM L-PORT - NB1 / MB1 (NB11, NB12, NB21, NB22 AND MB11, MB21)

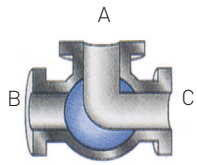

- A, B, C indicate the three supply ports.
- Quarter turn and L-port construction allow for the following two flow patterns. (Pattern 1 and Pattern 2)

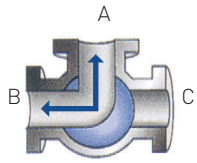

FLOW PLAN A (PATTERN 1)

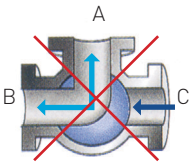

FLOW PLAN A (PATTERN 2)

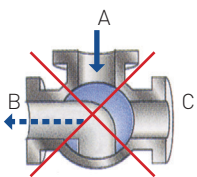

PATTERN 3

- Pattern 1 and Pattern 2 are standard flow directions for L-port valve.
- Arrows \rightarrow indicate pressure higher than 0 MPa. For vacuum use please inquire separately.
- Straight flow from B to C and C to B is not possible. (The operation rotates 90°.)
- Crossed out \times forms cannot be used.
- Leakage occurs on the flow channel side if the pressure of arrow \rightarrow is higher than the flow channel \rightarrow side.

NOTES

1. As for 2-seats (NB), Shut-off function is not available at the center port (A) because the seat is not installed there. Please pay attention to the direction of the flow channel when using it. In Pattern 3, the fluid pass through both flow channel A to B and B to A.
2. Please consult your local Emerson representative for 4 seats ASME Class 300 and JIS 20K valves (MB12/MB22)

OPERATION FORM T-PORT - MB1 (MB11, MB21)

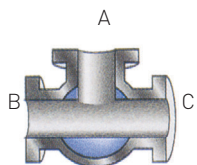

- A, B, C indicate the three supply ports.
- T-port available for below four patterns.

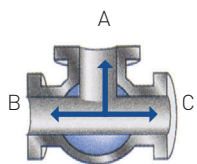

FLOW PLAN D (PATTERN 1)

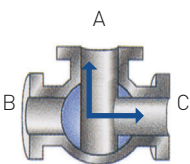

FLOW PLAN G (PATTERN 2)

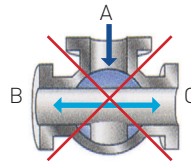
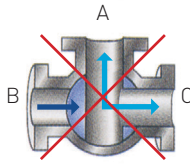
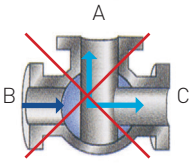
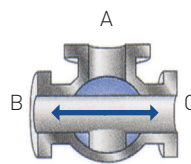
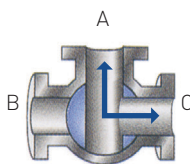

- Pattern 1 and Pattern 2 are standard flow directions for a 4-seat (T-port) valve.
- Arrows \rightarrow indicate pressure higher than 0 MPa. For vacuum use please inquire separately.
- Crossed out \times forms cannot be used.
- Leakage occurs on the flow channel side if the pressure of arrow \rightarrow is higher than the flow channel \rightarrow side.

NOTE

Please consult your local Emerson representative for 4 seats ASME Class 300 and JIS 20K valves (MB12/MB22)

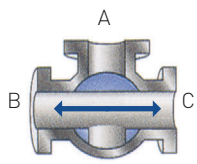

FLOW PLAN F (PATTERN 3)

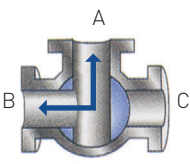

FLOW PLAN E (PATTERN 4)

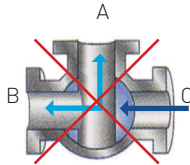
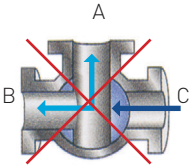
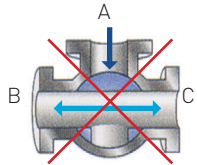
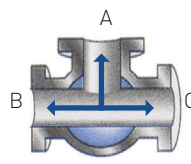
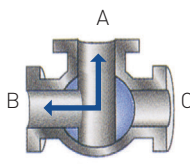

KTM SERIES NB / MB THREE-WAY BALL VALVES
2-SEATS (L-PORT) AND 4-SEATS (L AND T-PORT)

This page intentionally left blank.

VCTDS-02959-EN © 2014, 2021 Emerson Electric Co. All rights reserved 11/21. KTM is a mark owned by one of the companies in the Emerson Automation Solutions business unit of Emerson Electric Co. The Emerson logo is a trademark and service mark of Emerson Electric Co. All other marks are the property of their prospective owners.

The contents of this publication are presented for informational purposes only, and while every effort has been made to ensure their accuracy, they are not to be construed as warranties or guarantees, express or implied, regarding the products or services described herein or their use or applicability. All sales are governed by our terms and conditions, which are available upon request. We reserve the right to modify or improve the designs or specifications of such products at any time without notice.

Emerson Electric Co. does not assume responsibility for the selection, use or maintenance of any product. Responsibility for proper selection, use and maintenance of any Emerson Electric Co. product remains solely with the purchaser.

[Emerson.com/FinalControl](https://www.emerson.com/FinalControl)
