



## KTM SERIES EB7 UNIBODY FLOATING BALL VALVES

KTM Fire-safe and Anti-Static ASME 150/300 one piece, end entry, flanged ball valve for oil, gas, petrochemical and chemical industries



### FEATURES

- Designed to ASME B16.34, API 608 and ISO 17292.
- Optional testing to API 6D / ISO 14313.
- Single piece end entry body design complies with ASME B16.34.
- ISO 5211 top mounting flange.
- Face to Face to API 6D/ASME B16.10/BS 2080/BS EN 558.2.
- Fire tested to API 607 6th edition.
- Flange connection to ASME B16.5 as standard.
- One piece body offers total pipe integrity minimizing the number of potential leak paths.
- Carbon steel or stainless steel body as standard.
- Precision 316 stainless steel ball as standard.
- Blowout proof shouldered stem.
- Anti-static device.
- Cantilevered E-seat (PTFE/PFA copolymer) as standard.
- A secondary metal 'fire-safe' seat.
- Optional (DN 50 and above) cavity pressure bleed / vent fitting.
- External replaceable weather seal (DN 50/NPS 2 and above).
- Emergency seat and stem sealant facility (optional - DN 50/NPS 2 and above).
- Spring energized stem assembly to compensate for wear and temperature changes.
- Integral padlocking facility as standard.
- Vented ball equalizes body cavity pressure in open position and prevents possible seat damage.
- Manufactured under quality system ISO 9001 and API 6D Q1.
- All valves factory hydro/air tested to API 598.
- Certificate of compliance to EN 10204:2004. Type 3.1 are supplied as standard.

### GENERAL APPLICATIONS

Ideally suited for use in the oil and gas production, refining and chemical applications. Body material and wetted trim components conform to NACE MR0175-2002.

Hazardous areas handling flammable fuels, gases or chemicals where 'fire-safe', or anti-static valves are mandatory or desirable.

### TECHNICAL DATA

Model: EB7  
Sizes: DN 15 - 200 (NPS ½ - 8)  
Pressure rating: ASME Class 150, 300  
End Connection: ASME B16.5  
Raised face flange  
Temperature: -29°C - 232°C (-20°F - 450°F)

# KTM SERIES EB7 UNIBODY FLOATING BALL VALVES

**Note:** DN 25 (NPS 1) valve illustrated

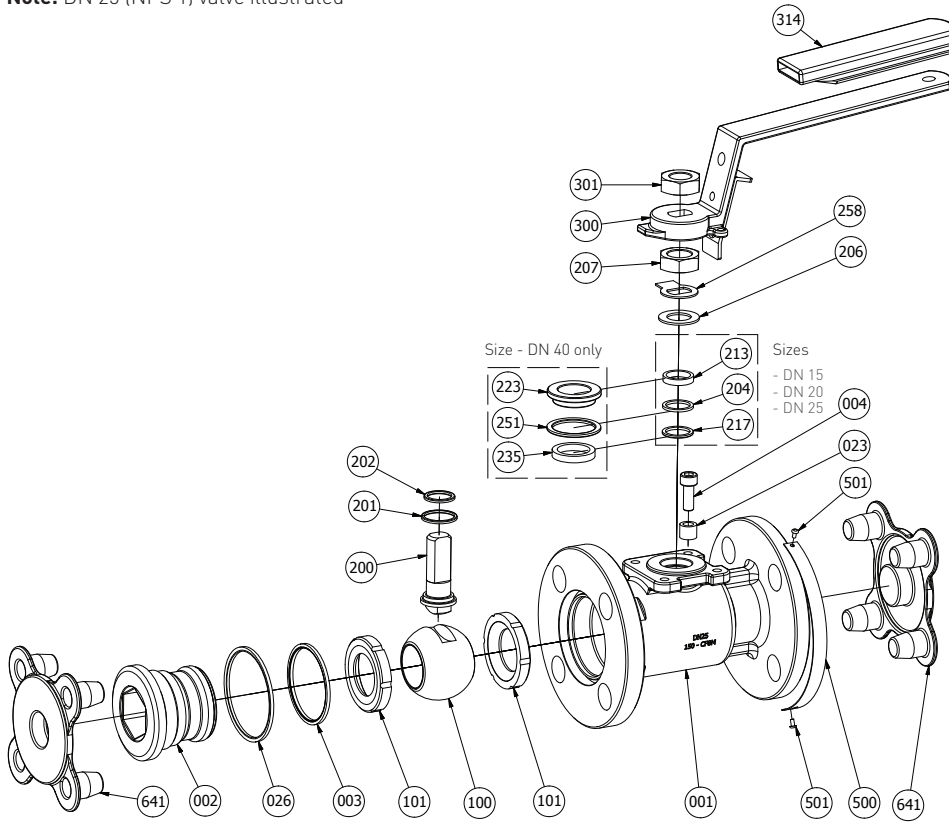

**Note:** DN 150 (NPS 6) valve illustrated

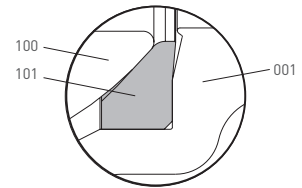
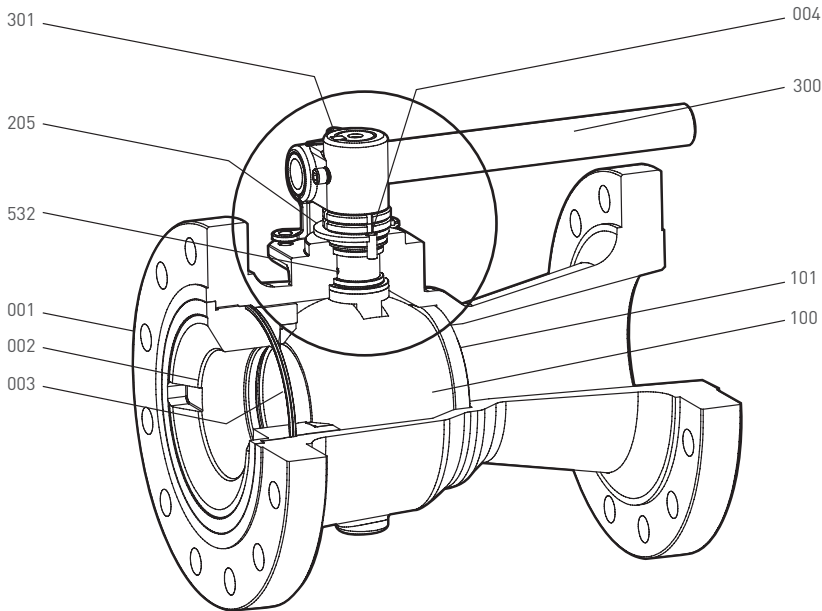

Cantilever seat detail

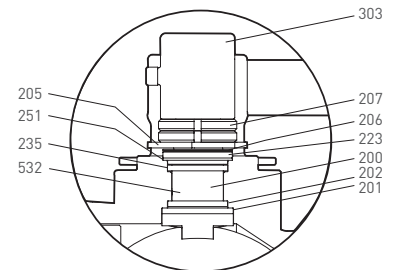

Stem section detail DN 50-200 (NPS 2 - 8)

# KTM SERIES EB7 UNIBODY FLOATING BALL VALVES

## PARTS LIST

No.	Description	Carbon steel	Stainless steel
001	Body	ASTM A216-WCB/WCC Dual certified	ASTM A351-CF8M
002	Body insert	ASTM A216-WCB/WCC Dual certified	ASTM A351-CF8M
003	Body insert seal	Virgin PTFE	Virgin PTFE
004	Stop screw DN 15 - 50 (NPS ½ - 2)	UNS S31600	UNS S31600
004	Stop pin DN 80 - 200 (NPS 3 - 8)	Alloy steel	UNS S31600
023	Stop pin spacer DN 15 - 50 (NPS ½ - 2)	UNS S31600	UNS S31600
026	Firesafe body seal DN 15 - 40 (NPS ½ - 1½) only	Flexible graphite	Flexible graphite
100	Ball	UNS S31600	UNS S31600
101	Seat (Code E - Cantilevered)	PTFE/PFA copolymer	PTFE/PFA copolymer
	Seat (Code G - Cantilevered)	Carbon reinforced PTFE	Carbon reinforced PTFE
200	Stem (Standard)	UNS S31600	UNS S31600
	Stem (High strength)	(Optional - UNS S17400)	(Optional - UNS S17400)
201	Primary stem seal	Glass reinforced PTFE	Glass reinforced PTFE
202	Firesafe stem seal	Flexible graphite	Flexible graphite
204	Stem thrust washer DN 15 - 25 (NPS ½ - 1)	Glass reinforced PTFE	Glass reinforced PTFE
205	Stop plate DN 80 - 200 (NPS 3 - 8)	UNS S31600	UNS S31600
206	Stem spring	Inconel	Inconel
207	Stem nut	UNS S31600	UNS S31600
213	Gland DN 15 - 25 (NPS ½ - 1)	UNS S31600	UNS S31600
217	Gland packing DN 15 - 25 (NPS ½ - 1)	Flexible graphite	Flexible graphite
223	Stem seal follower DN 40 - 200 (NPS 1½ - 8)	UNS S31600	UNS S31600
235	Aux. stem seal DN 40 - 200 (NPS 1½ - 8)	Virgin PTFE	Virgin PTFE
251	Weather seal DN 40 - 200 (NPS 1½ - 8)	Comp. carbon fiber	Comp. carbon fiber
258	Lock washer DN 15 - 50 (NPS ½ - 2)	UNS S31600	UNS S31600
300	Lever DN 15 - 50 (NPS ½ - 2)	UNS S31600	UNS S31600
	Lever DN 80 - 200 (NPS 3 - 8)	Carbon steel zinc plated (Optional - UNS S31600)	Carbon steel zinc plated (Optional - UNS S31600)
301	Lever retainer	Carbon steel zinc plated (Optional - UNS S31600)	Carbon steel zinc plated (Optional - UNS S31600)
303	Lever head DN 80 - 200 (NPS 3 - 8)	S.G. iron (prime coated) (Optional - UNS S31600)	S.G. iron (prime coated) (Optional - UNS S31600)
532	Anti-Static device DN 80 - 200 (NPS 3 - 8)	UNS S31600/Inconel	UNS S31600/Inconel
641	Flange cover	Plastic	Plastic

**Note:** pressure containing materials conform to NACE standard MR0175-2002.

# KTM SERIES EB7 UNIBODY FLOATING BALL VALVES

## METRIC DATA

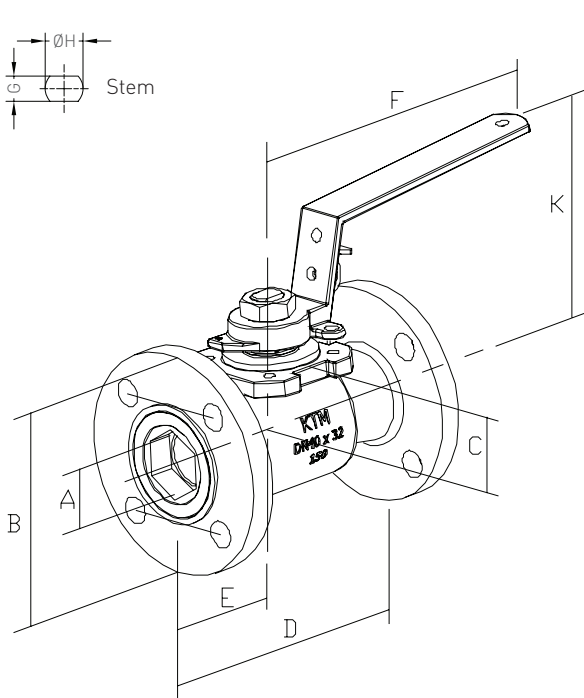

Note: DN 40 valve illustrated

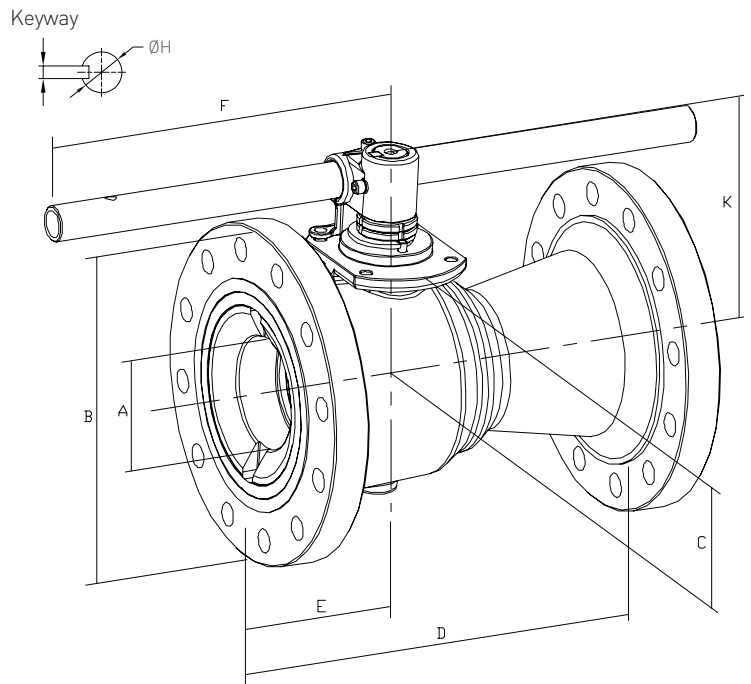

Note: DN 150 valve illustrated

### DIMENSIONS DN 15 - DN 40 (Full bore)

Valve size		ØB			C	D			Stem connection		Top plate data			Mass (kg)		K <sub>v</sub> at		
DN	Bore ØA	Class		150		Class		E	F	K	ØH x G	Key	No. holes	Hole dia.	PCD	150	300	150
15	13	90	95	22.5	108	140	56.0	145	95	9.5 x 6.3	-	4	M06	50	2.0	2.0	7.9	
20	19	100	115	30.0	117	152	63.0	180	106	14.3 x 9.5	-	4	M06	50	2.5	2.5	26.2	
25	25	110	125	34.5	127	165	65.0	180	111	14.3 x 9.5	-	4	M06	50	3.5	3.5	45.3	
40	38	125	155	47.5	165	190	87.6	200	127	19 x 12.7	-	4	M08	70	6.5	10.0	132.0	

### DIMENSIONS DN 50 - DN 200 (Reduced bore)

Valve size		ØB			C	D			Stem connection		Top plate data			Mass (kg)		K <sub>v</sub> at		
DN	Bore ØA	Class		150		Class		E	F	K	ØH x G	Key	No. holes	Hole dia.	PCD	150	300	150
50	38	150	165	47.5	178	216	89.0	200	134	19 x 12.7	-	4	M08	70	8.5	11.0	139	152
80	63	190	210	85.0	203	283	103.3	427	158	22 x 15.9	-	4	M10	102	18.5	26.0	351	357
100	76	230	255	97.0	229	305	114.5	427	170	22 x 15.9	-	4	M10	102	29.5	40.5	532	600
150	102	280	320	124.0	267	403	133.5	625	220	32	10 x 10	4	M12	125	52.0	78.0	578	832
200	150	345	380	159.0	292	419	161.0	966	255	32	10 x 10	4	M12	125	98.0	118.0	1280	1558

### NOTES

F = The lever dimension when the handle is in the extended position.

H = The diameter of the stem connection.

G = The dimension across the stem flats.

K<sub>v</sub> = The flow rate of water in m<sup>3</sup>/hr that will pass through a valve with a pressure drop of 1 bar (100 kPa) at 20°C.

C<sub>v</sub> = 1.155 K<sub>v</sub>      K<sub>v</sub> = C<sub>v</sub>/1.155

Dimensions are nominal to ±1 mm.

# KTM SERIES EB7 UNIBODY FLOATING BALL VALVES

## IMPERIAL DATA

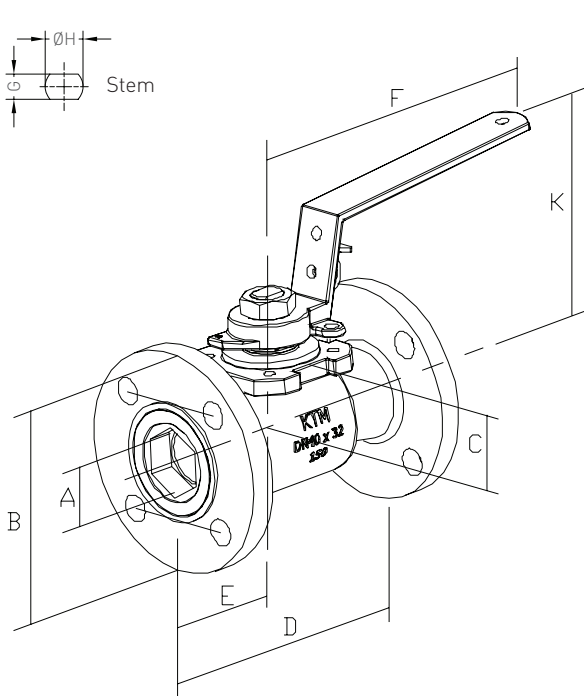

Note: NPS 1½ valve illustrated

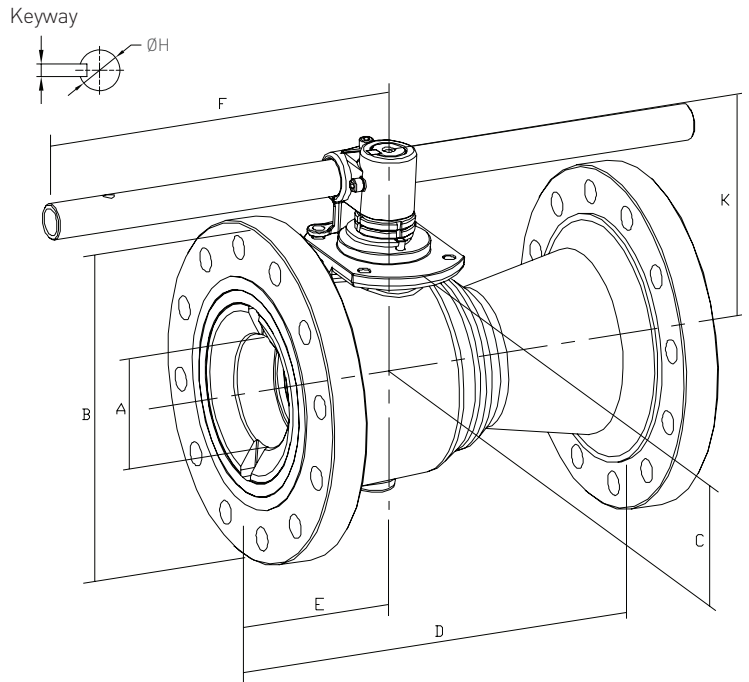

Note: NPS 6 valve illustrated

### DIMENSIONS NPS ½ - NPS 1½ (Full bore)

Valve size	NPS	Bore ØA	ØB		C	D			Shaft connection		Top plate data			Mass (lbs)		K <sub>v</sub> at		
			Class 150	Class 300		Class 150	Class 300	E	F	K	ØH x G	Key	No. holes	Hole dia.	PCD	Class 150	Class 300	Class 150
½		0.50	3.54	3.74	0.89	4.25	5.50	2.20	5.70	3.74	0.37 x 0.25	-	4	M06	2.00	4.4	4.4	7.9
¾		0.75	3.94	4.53	1.18	4.60	5.98	2.48	7.10	4.20	0.56 x 0.37	-	4	M06	2.00	5.5	5.5	26.2
1		1.00	4.33	4.92	1.35	5.00	6.50	2.60	7.10	4.37	0.56 x 0.37	-	4	M06	2.00	7.7	7.7	45.3
1½		1.50	4.92	6.10	1.87	6.50	7.48	87.60	7.87	5.00	0.75 x 0.50	-	4	M08	2.75	14.3	22.0	132.0

### DIMENSIONS NPS 2 - NPS 8 (Reduced bore)

Valve size	NPS	Bore ØA	ØB		C	D			Shaft connection		Top plate data			Mass (lbs)		K <sub>v</sub> at			
			Class 150	Class 300		Class 150	Class 300	E	F	K	ØH x G	Key	No. holes	Hole dia.	PCD	Class 150	Class 300	Class 150	Class 300
2		1.5	5.90	6.5	1.87	7.0	8.5	3.5	7.9	5.3	0.75 x 0.5	-	4	M08	2.75	18.7	24.3	139	152
3		2.5	7.48	8.3	3.35	8.0	11.1	4.1	16.8	6.2	0.87 x 0.63	-	4	M10	4.00	40.8	57.3	351	357
4		3.0	9.10	10.0	3.82	9.0	12.0	4.5	16.8	6.7	0.87 x 0.63	-	4	M10	4.00	65.0	89.3	532	600
6		4.0	11.00	12.6	4.88	10.5	15.9	5.3	24.6	8.7	1.26	10 x 10 #	4	M12	4.90	114.6	172.0	578	832
8		6.0	13.60	15.0	6.26	11.5	16.5	6.3	39.0	10.0	1.26	10 x 10 #	4	M12	4.90	216.0	260.0	1280	1558

### NOTES

F = The lever dimension when the handle is in the extended position.

H = The diameter of the stem connection.

G = The dimension across the stem flats.

K<sub>v</sub> = The flow rate of water in US gallon per minute that will pass through a valve with a pressure drop of 1 psi at 68°F.

C<sub>v</sub> = 1.155 K<sub>v</sub>      K<sub>v</sub> = C<sub>v</sub>/1.155

# = Metric stem keyway is used on NPS 6 and 8 valves.

Dimensions are nominal to ±0.03".

# KTM SERIES EB7 UNIBODY FLOATING BALL VALVES

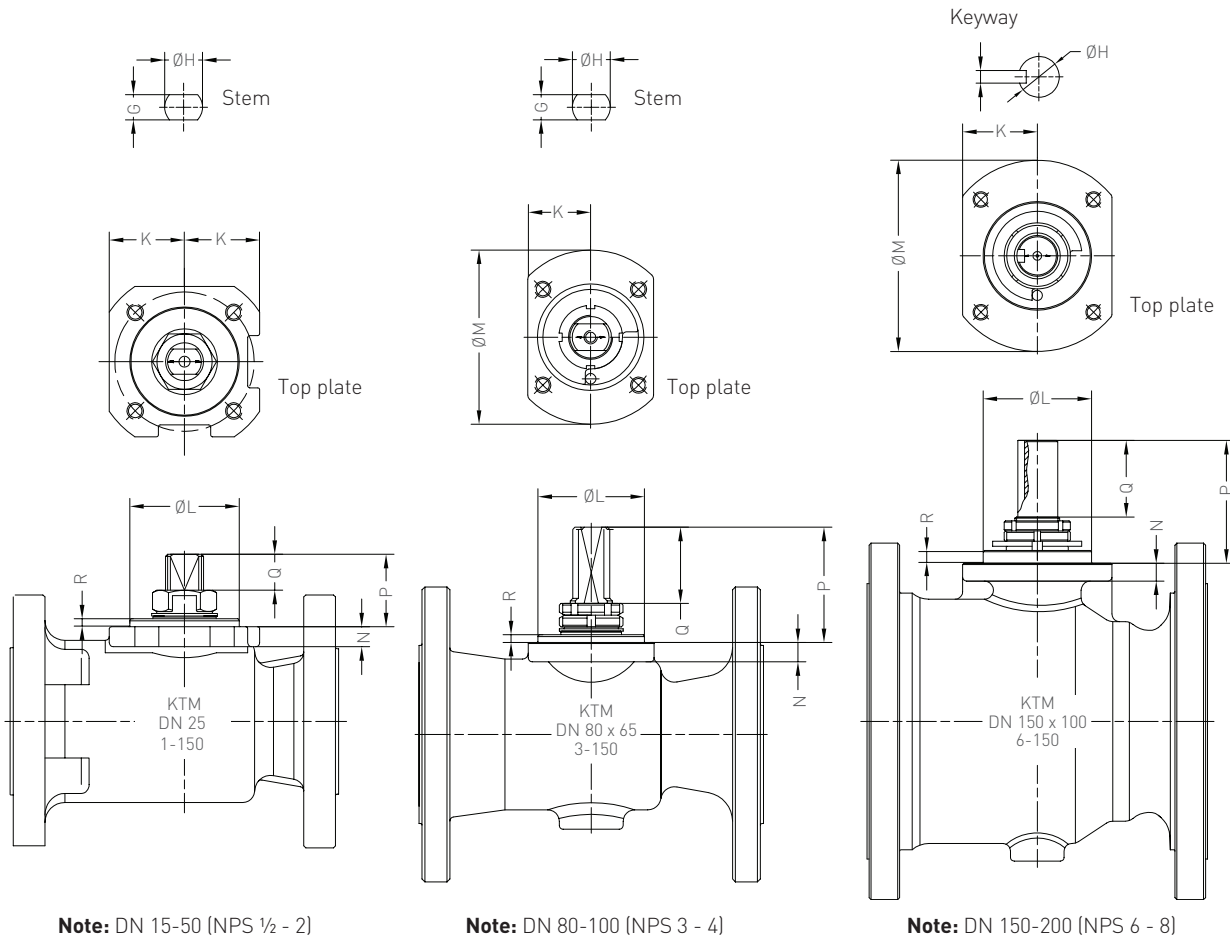

## TOP WORK DIMENSIONS DN 15 - DN 200 (Metric)

Valve size	ISO MTG code	Stem connection		Top plate data			Dimensions						
		ØH x G	Key	No. holes	Hole dia.	PCD	P	Q	M	K	L	N	R
15	F05	9.5 x 6.3	-	4	M06	50	19.0	8.5	-	25.0	35	6.5	2
20	F05	14.3 x 9.5	-	4	M06	50	29.5	15.5	-	25.0	35	6.5	2
25	F05	14.3 x 9.5	-	4	M06	50	29.5	15.5	-	25.0	35	6.5	2
40	F07	19 x 12.7	-	4	M08	70	37.0	18.0	-	37.5	55	10.0	4
50	F07	19 x 12.7	-	4	M08	70	37.0	18.5	75	37.5	55	10.0	4
80	F10	22 x 15.9	-	4	M10	102	73.0	42.0	126	47.5	70	10.0	5
100	F10	22 x 15.9	-	4	M10	102	73.0	42.0	126	47.5	70	10.0	5
150	F12	32	10 x 10	4	M12	125	96.0	60.0	151	58.5	85	14.0	10
200	F12	32	10 x 10	4	M12	125	96.0	60.0	151	58.5	85	15.0	10

## TOP WORK DIMENSIONS NPS ½ - NPS 8 (Imperial)

Valve size	ISO MTG code	Stem connection		Top plate data			Dimensions						
		ØH x G	Key	No. holes	Hole dia.	PCD	P	Q	M	K	L	N	R
½	F05	0.373 x 0.247	-	4	M06	2.00	0.75	0.33	-	0.98	1.38	0.26	0.08
¾	F05	0.562 x 0.373	-	4	M06	2.00	1.16	0.61	-	0.98	1.38	0.26	0.08
1	F05	0.562 x 0.373	-	4	M06	2.00	1.16	0.61	-	0.98	1.38	0.26	0.08
1½	F07	0.75 x 0.5	-	4	M08	2.75	1.46	0.71	-	1.48	2.17	0.40	0.16
2	F07	0.75 x 0.5	-	4	M08	2.75	1.46	0.72	2.95	1.48	2.17	0.40	0.16
3	F10	0.865 x 0.625	-	4	M10	4.00	2.88	1.65	4.96	1.87	2.76	0.40	0.20
4	F10	0.865 x 0.625	-	4	M10	4.00	2.88	1.65	4.96	1.87	2.76	0.40	0.20
6	F12	1.259	10 x 10 #	4	M12	4.92	3.78	2.36	5.95	2.30	3.35	0.55	0.40
8	F12	1.259	10 x 10 #	4	M12	4.92	3.78	2.36	5.95	2.30	3.35	0.59	0.40

**Note:**

# = Metric stem keyway is used on DN 150 and DN 200 (NPS 6 and NPS 8)

# KTM SERIES EB7 UNIBODY FLOATING BALL VALVES

PRESSURE/TEMPERATURE GRAPH

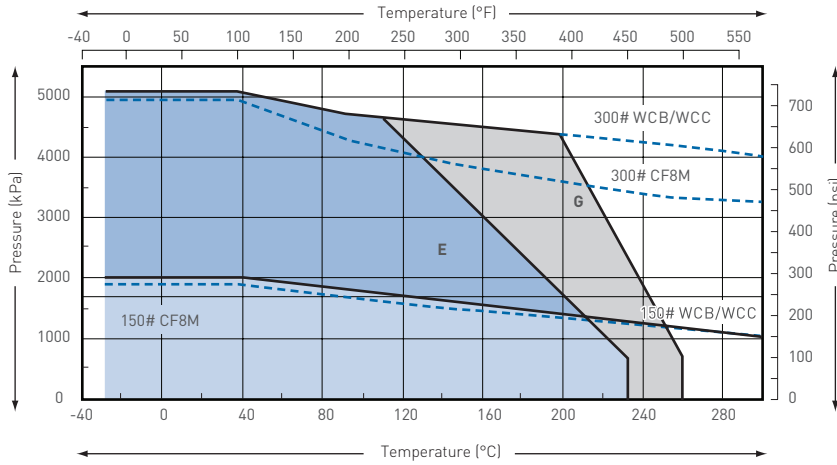

**E** - PTFE/PFA copolymer cantilevered seat  
**G** - R'PTFE cantilevered seat

**NOTE**

1. These pressure/temperature ratings displayed are for total valve assembly with the respective seat material fitted.
2. Carbon steel valves have a minimum temperature limitation of minus 29°C (-20°F).

**PRESSURE/TEMP RATINGS**

**Class 150**

**PTFE/PFA copolymer**

**Carbon steel:**

ASTM A216-WCB/WCC dual certified  
 1980 kPa/19.8 bar max at 38°C  
 (287 psi max at 100°F)

**Stainless steel:**

ASTM A351-CF8M  
 1900 kPa/19 bar max at 38°C  
 (276 psi max at 100°F)

**Carbon reinforced PTFE**

**Carbon steel:**

ASTM A216-WCB/WCC dual certified  
 1980 kPa/19.8 bar max at 38°C  
 (287 psi max at 100°F)

**Stainless steel:**

ASTM A351-CF8M  
 1900 kPa/19 bar max at 38°C  
 (276 psi max at 100°F)

**Class 300**

**PTFE/PFA copolymer**

**Carbon steel:**

ASTM A216-WCB/WCC dual certified  
 5170 kPa/51.7 bar max at 38°C  
 (750 psi max at 100°F)

**Stainless steel:**

ASTM A351-CF8M  
 4960 kPa/49.6 bar max at 38°C  
 (719 psi max at 100°F)

**Carbon reinforced PTFE**

**Carbon steel:**

ASTM A216-WCB/WCC dual certified  
 5170 kPa/51.7 bar max at 38°C  
 (750 psi max at 100°F)

**Stainless steel:**

ASTM A351-CF8M  
 4960 kPa/49.6 bar max at 38°C  
 (719 psi max at 100°F)

Neither Emerson, Emerson Automation Solutions, nor any of their affiliated entities assumes responsibility for the selection, use or maintenance of any product. Responsibility for proper selection, use, and maintenance of any product remains solely with the purchaser and end user.

KTM is a mark owned by one of the companies in the Emerson Automation Solutions business unit of Emerson Electric Co. Emerson Automation Solutions, Emerson and the Emerson logo are trademarks and service marks of Emerson Electric Co. All other marks are the property of their respective owners.

The contents of this publication are presented for informational purposes only, and while every effort has been made to ensure their accuracy, they are not to be construed as warranties or guarantees, express or implied, regarding the products or services described herein or their use or applicability. All sales are governed by our terms and conditions, which are available upon request. We reserve the right to modify or improve the designs or specifications of such products at any time without notice.

[Emerson.com/FinalControl](https://www.emerson.com/FinalControl)