

**KTM GRATITE<sup>®</sup> SEAT HI-TEMP BALL VALVES**

FLOATING

KTM's GratiTe<sup>®</sup> seat ball valve not only operates across an impressive range of temperatures, from -29°C to 500°C, it also boasts outstanding performance and a reliability, making it ideal for high pressure, fire-proof, anti-corrosion and other key process lines.

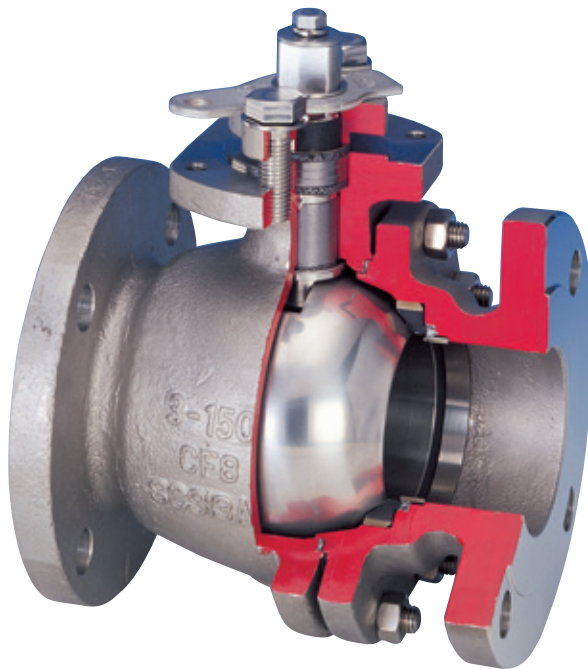

**FEATURES**

- Hard graphite with excellent self-lubrication and anti-corrosion properties is adopted to the seat and flexible graphite to the cushion seal
- Hard graphite seats and the graphite packing ensure a wide operating temperature range from -29°C to 500°C
- GratiTe<sup>®</sup> offers superior cost effectiveness in comparison to the metal seated valves
- High resistance to thermal shock prevents the cracking caused by thermal shock seen in ceramics
- With high conductivity, GratiTe<sup>®</sup> has an anti-static function
- Blowout-proof stem (ASME Class 600 optional)
- A two-piece body construction makes maintenance easier
- The product features a fire safe design
- Easy actuator mounting
- It can be used for both flow directions (ASME Class 600, DN 50 to DN 100 is unidirectional flow).
- GratiTe<sup>®</sup> boasts outstanding sealing characteristics
  - Water pressure: Zero leakage
  - Air pressure: 10 cc / min / inch
  - (10 cc / min for the size of DN 25 or less)

**GENERAL APPLICATIONS**

Chemical plant, oil refinery, power plant, steam, Dowtherm<sup>®</sup>, fused alkali, fuel oil and gas

**Special options**

- Extension bonnet
- Jacketed ball valve
- Special tests
  - X-ray (RT)
  - Liquid penetrant (PT)
  - Positive material identification (PMI)

**TECHNICAL DATA**

Models / Sizes: EB1 DN 15 to DN 200 (NPS ½ to NPS 8)  
 Class 150 and Class 300  
 EB2 Reduced Bore  
 DN 15 to DN 200 (NPS ½ to NPS 8)  
 E01 Full Bore  
 DN 15 to DN 100 (NPS ½ to NPS 4) Class 600

Pressure rating: JIS 10K, 20K / ASME Class 150, 300 and 600 (JPI available)

Face to face: ASME B16.10 / JIS B2002

End connection: ASME B16.5 / JIS B2220

Temperature: -29°C to 500°C (-20°F to 932°F)  
 Up to 450°C/842°F for oxidizing condition

# KTM GRATITE® SEAT HI-TEMP BALL VALVES

## FLOATING

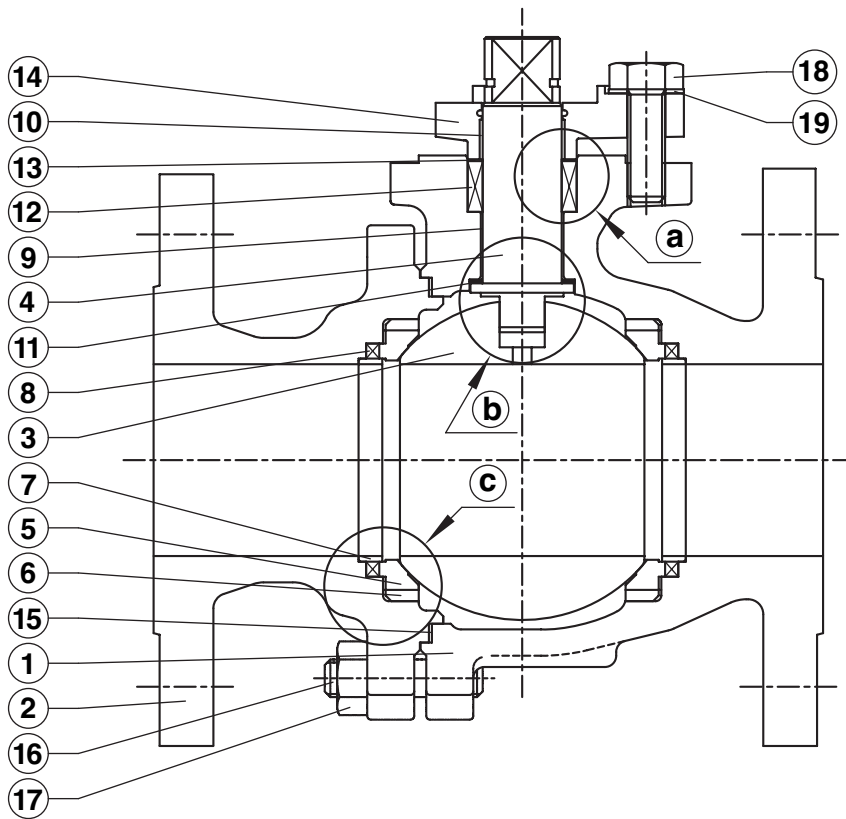

(A) GLAND AREA

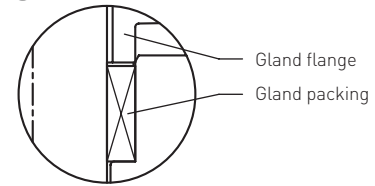

The graphite packing has a fire safe design that makes it suitable for high temperature environments.

(B) STEM AREA

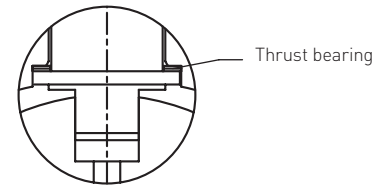

The flanged stem is prevented from blowing out in the event of a packing loss.

(C) SEAT AREA

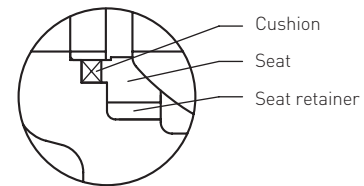

The Gratite® seat has impressive sealing performance. The cushion seal absorbs thermal expansion to ensure stable operation.

This figure shows a product in ASME150, 300 (JIS10K, 20K).

### PARTS LIST

No	Part name	Model no			Qty
		EB1 / EB2	EB1 / EB2	EB1 / EB2	
1	Body	WCB (SCPH2)	CF8 (SCS13A)	CF8M (SCS14A)	1
2	Body cap	WCB (SCPH2)	CF8 (SCS13A)	CF8M (SCS14A)	1
3	Ball	CF8 (SCS13A)	CF8 (SCS13A)	CF8M (SCS14A)	1
4	Stem	SUS329J1 (329SS)	SUS329J1 (329SS)	SUS329J1 (329SS)	1
5	Seat	Gratite®	Gratite®	Gratite®	2
6	Seat retainer	316SS	316SS	316SS	2
7	Inner ring	316SS	316SS	316SS	2
8	Cushion	Graphite	Graphite	Graphite	2
9	Stem bearing	Graphite	Graphite	Graphite	1
10	Stem bearing	Graphite	Graphite	Graphite	1
11	Thrust bearing	316SS	316SS	316SS	2
12	Gland packing	Graphite	Graphite	Graphite	1set
13	Packing washer	316SS	316SS	316SS	1
14	Gland flange	CF8 (SCS13A)	CF8 (SCS13A)	CF8 (SCS13A)	1
15	Gasket	Graphite	Graphite	Graphite	1
16	Stud	A193 GB7	A193 GB8	A193 GB8	4-12
17	Nut	A194 G2H	A194 G8	A194 G8	4-12
18	Gland bolt	A193 GB8	A193 GB8	A193 GB8	2
19	Live loading spring	304SS (SUS304)	304SS (SUS304)	304SS (SUS304)	2

• Materials in parentheses indicate equivalent JIS material.

# KTM GRATITE® SEAT HI-TEMP BALL VALVES

## FLOATING

### GRATITE® SEAT

A proprietary product for high-temperature, high-pressure, flammable and corrosive critical process applications, the KTM Gratite® seat offers superior performance and reliability. Gratite® as a bonded composite of graphite material in high temperature and high pressure is designed to operate within a temperature range from -29°C to +500°C. The cushion provides resiliency during thermal expansion-contraction. The result is a Gratite® seat with physical properties that are far superior to conventional ball valve seats of carbon graphite construction.

Gratite® is a registered trade name of Emerson Japan. Co., Ltd.

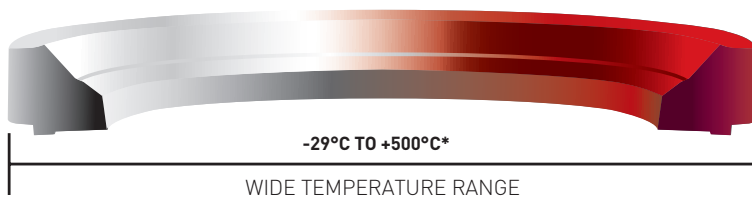

\* Up to 450°C for oxidizing condition.

### PRESSURE-TEMPERATURE RATING

Please note that pressure temperature rating for valves vary from body materials.

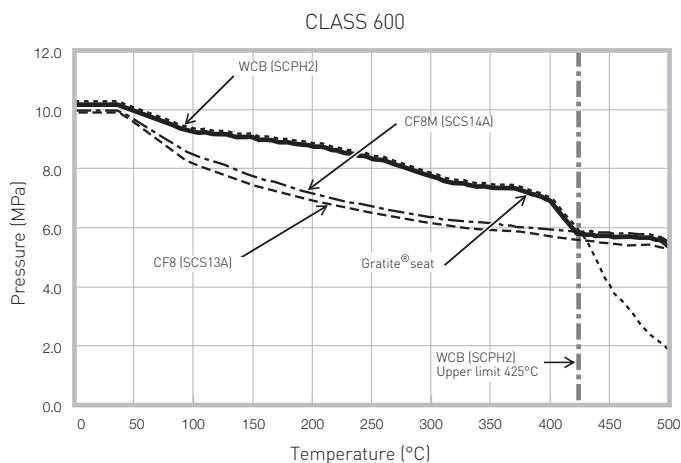
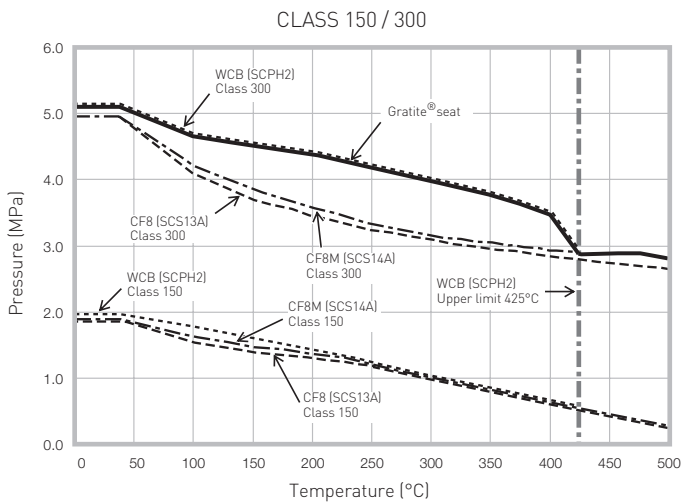

- Solid line — indicate Gratite® seat rating.
- Dashed lines indicate body ratings.
  - WCB
  - CF8
  - CF8M
- Material in parentheses indicate equivalent JIS material

# KTM GRATITE® SEAT HI-TEMP BALL VALVES

## FLOATING

### CLASS 150 / 300

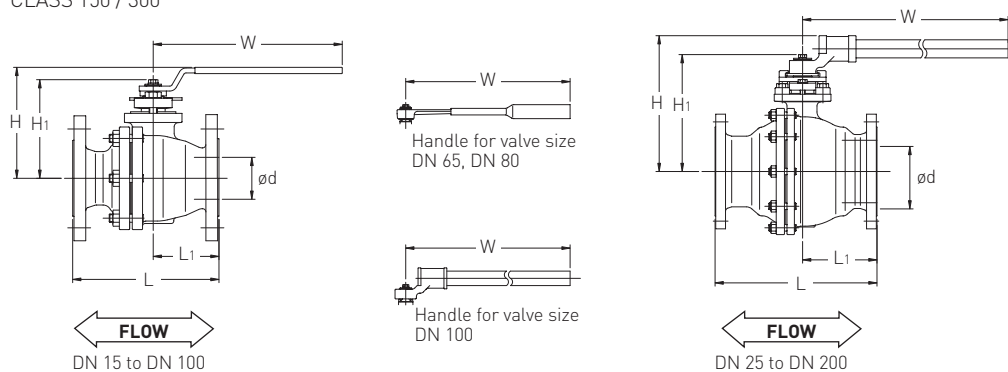

### JIS10K, 20K ASME CLASS 150, 300 DIMENSIONS (mm)

Size (DN)	ød	JIS10K Class 150 / EB11		JIS20K Class 300 / EB12		H	H <sub>1</sub>	W
		L	L <sub>1</sub>	L	L <sub>1</sub>			
15	13	108	47	140	62	81	64	200
20	19	117	51	152	72	85	68	200
25	25	127	55	165	73	98	80	240
40	38	165	75	190	80	125	110	350
50	51	178	80	216	90	135	120	350
65	64	190	88	241	107	-	165	600
80	76	203	98	283	120	-	174	600
100	102	229	115	305	145	240	200	1130
125	127	356	140	381	155	311	265	1740
150	152	394	181	403	190	331	285	1740
200	203	457	225	502	235	414	368	2345

### JIS10K, 20K ASME CLASS 150, 300 DIMENSIONS (inch)

Size (NPS)	ød	JIS10K Class 150 / EB11		JIS20K Class 300 / EB12		H	H <sub>1</sub>	W
		L	L <sub>1</sub>	L	L <sub>1</sub>			
1/2	0.50	4.3	1.85	5.51	2.44	3.19	2.52	7.87
3/4	0.75	4.6	2.01	5.98	2.83	3.35	2.68	7.87
1	1.00	5.0	2.17	6.50	2.87	3.86	3.15	9.45
1 1/2	1.50	6.5	2.95	7.48	3.15	4.92	4.33	13.78
2	2.00	7.0	3.15	8.50	3.54	5.31	4.72	13.78
2 1/2	2.50	7.5	3.46	9.49	4.21	-	6.50	23.62
3	3.00	8.0	3.86	11.14	4.72	-	6.85	23.62
4	4.00	9.0	4.53	12.01	5.71	9.45	7.87	44.49
5	2.50	14.0	5.51	15.00	6.10	12.24	10.43	68.50
6	6.00	15.5	7.13	15.87	7.48	13.03	11.22	68.50
8	8.00	18.0	8.86	19.76	9.25	16.30	14.49	92.32

# KTM GRATITE® SEAT HI-TEMP BALL VALVES

## FLOATING

### CLASS 600

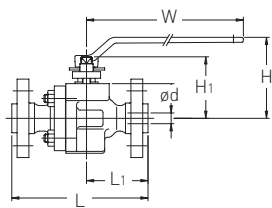

← FLOW →  
Sizes DN 15 to 40

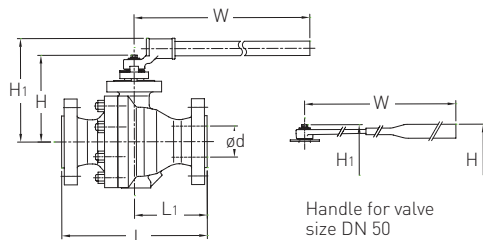

← FLOW →  
Sizes DN 50 and DN 80

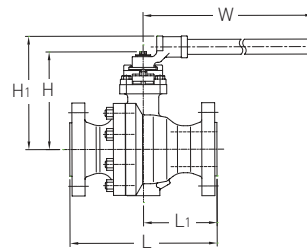

← FLOW →  
Sizes DN 100

### ASME CLASS 600 DIMENSIONS (mm)

Size (DN)	Ød	RF (Raised Face)		RTJ (Ring Type Joint)		H	H <sub>1</sub>	W
		L	L <sub>1</sub>	L	L <sub>1</sub>			
15	13	165	74.5	163	73.5	98	75	240
20	19	190	87.0	190	87.0	105	82	240
25	25	216	100.0	216	100.0	124	101	350
40	38	241	110.5	241	110.5	134	111	350
50	51	292	126.0	295	127.5	192	192	600
80	76	356	178.0	359	179.5	253	212	1130
100	102	432	216.0	435	217.5	333	287	1740

### ASME CLASS 600 DIMENSIONS (inch)

Size (NPS)	Ød	RF (Raised Face)		RTJ (Ring Type Joint)		H	H <sub>1</sub>	W
		L	L <sub>1</sub>	L	L <sub>1</sub>			
1/2	0.50	6.50	2.93	6.42	2.89	3.86	2.95	9.45
3/4	0.75	7.48	3.43	7.48	3.43	4.13	3.23	9.45
1	1.00	8.50	3.94	8.50	3.94	4.88	3.98	13.78
1 1/2	1.50	9.49	4.35	9.49	4.35	5.28	4.37	13.78
2	2.00	11.50	4.96	11.61	5.02	7.56	7.56	23.62
3	3.00	14.02	7.01	14.13	7.07	9.96	8.35	44.49
4	4.00	17.01	8.50	17.13	8.56	13.11	11.30	68.50

# KTM GRATITE® SEAT HI-TEMP BALL VALVES

## FLOATING

### CORROSION RESISTANCE AND APPLICATION TEMPERATURE FOR GRATITE® SEAT

	Fluid	Density (%)	Temperature (°C)	Corrosion resistance
1	Acidum hydrochloricum	all	boiling point	Please contact us
2	Chromic acid	10%	93°C	Please contact us
3	Nitric acid	10%	85°C	Please contact us
4	Nitric acid	10 - 20%	60°C	NG
5	Nitric acid	20%<	-	NG
6	Carbonic acid	all	boiling point	OK
7	Hydrofluoric acid	48%	boiling point	Please contact us
8	Boric acid	all	boiling point	OK
9	Hydrosulfuric acid	all	boiling point	OK
10	Sulfuric acid	75%	130°C	Please contact us
11	Sulfuric acid	75 - 96%	80°C	NG
12	Sulfuric acid	96%<	-	NG
13	Phosphoric acid	85%	boiling point	Please contact us
14	Phosphoric acid	96%	100°C	Please contact us
15	Formic acid	all	boiling point	Please contact us
16	Citric acid	all	boiling point	OK
17	Acetic acid	all	boiling point	OK
18	Anhydrous acetic acid	100%	boiling point	OK
19	Oxalic acid	all	boiling point	OK
20	Stearic acid	100%	170°C	OK
21	Tannic acid	all	170°C	OK
22	Acidum lacticum	all	boiling point	OK
23	Ammonia water	all	boiling point	OK
24	Caustic soda	67%	boiling point	Please contact us
25	Caustic soda	67 - 80%	125°C	Please contact us
26	Ferrous chloride	all	100°C	Please contact us
27	Ferric chloride	all	boiling point	Please contact us
28	Sodium chloride	all	boiling point	OK
29	Sodium hypochlorite	5%	room temperature	Please contact us
30	Sodium carbonate	all	50°C	OK
31	Zinc sulfate	all	boiling point	OK
32	Copper sulfate	all	boiling point	OK
33	Chlorine	100%	room temperature	Please contact us
34	Chlorine water	saturation	room temperature	Please contact us
35	Bromine	100%	-	NG
36	Bromine water	saturation	room temperature	Please contact us
37	Fluorine	100%	-	NG
38	Iodine	100%	-	NG
39	Acetone	100%	boiling point	OK
40	Isopropyl alcohol	100%	boiling point	OK
41	Ethyl alcohol	100%	boiling point	OK
42	LPG	all	-100°C	OK
43	Ethane tetrachloride	100%	boiling point	OK
44	Ethylene oxide	all	170°C	OK
45	Carbon tetrachloride	100%	boiling point	OK
46	VCM	100%	170°C	OK
47	Gasoline	100%	boiling point	OK
48	Glycerin	100%	170°C	OK
49	Chloroform	100%	boiling point	OK
50	Kerosene	100%	boiling point	OK
51	Dowtherm®	100%	-	Please contact us
52	Butyl alcohol	100%	boiling point	OK
53	Benzene	100%	boiling point	OK
54	Naphtha	100%	150°C	OK
55	Water	-	boiling point	OK
56	Water vapor	-	100°C	OK
57	Air	-	300°C	OK

#### NOTE

This list should be used only as reference.

Please consult us about your usage.

Neither Emerson, Emerson Automation Solutions, nor any of their affiliated entities assumes responsibility for the selection, use or maintenance of any product. Responsibility for proper selection, use, and maintenance of any product remains solely with the purchaser and end user.

KTM is a mark owned by one of the companies in the Emerson Automation Solutions business unit of Emerson Electric Co. Emerson Automation Solutions, Emerson and the Emerson logo are trademarks and service marks of Emerson Electric Co. All other marks are the property of their respective owners.

The contents of this publication are presented for informational purposes only, and while every effort has been made to ensure their accuracy, they are not to be construed as warranties or guarantees, express or implied, regarding the products or services described herein or their use or applicability. All sales are governed by our terms and conditions, which are available upon request. We reserve the right to modify or improve the designs or specifications of such products at any time without notice.

[Emerson.com/FinalControl](https://www.emerson.com/FinalControl)

---