

NELES

Jamesbury™ 4" 9RET/REL full-port bottom-outlet valves (AAR no. E172109)

DESCRIPTION

The new 4" 9RET and 9REL flanged ball valves are reduced weight bottom-outlet valves and are available in a wide variety of materials to satisfy most tank car applications.

Specifically designed for tank car applications, the valve ensures fast handling of almost all materials including abrasive slurries and viscous fluids. This ball valve offers the advantages of quick quarter- turn operation, long service life, and easy cycling.

It is much faster to operate than multi-turn types of valves. In addition, it is easy to cycle even after being set in one position for an extended period.

The valve is optionally available with a full-steam jacket.

UNIQUE SEALING

The superior performance of Jamesbury™ bottom outlet valves is achieved by the unique design of the seat. The flexible-lip seats exert continuous sealing pressure on the ball. The seat automatically compensates for wear and for changes in temperature and pressure.

In addition, this valve is designed to withstand the demanding service requirements of the railroad industry.

MATERIALS

The 9RET and 9REL valves are available in carbon steel with 316 stainless steel trim and all 316 stainless steel. Other materials are available for special applications.

FIRE-TITE™ DESIGN

All Jamesbury tank car ball valves have the Fire-Tite design tested to API-607. In the event of a fire resulting in partial or complete destruction of the PTFE seats, a secondary metal sealing surface provides continuous effective shutoff. API 608 compliance to serve refineries and related chemical and petrochemical industries except face to face dimension. Flange connection per AAR specifications.



FLOW DATA

The 4" 9RET and 4" 9REL have an installed Cv value of 2200. Cv is defined as the flow of water through the valve in U.S. gallons per minute at a pressure drop of 1 psi. This Cv value is an estimate of the installed flow capacity and considers typical inlet losses.

RATINGS

9RET and 9REL valves are rated for pressures and temperatures well in excess of those that are normally encountered in tank car service. Carbon steel valves are rated from -20°F to +400°F (-29°C to +204°C). 316 stainless steel valves are rated from -60°F to +400°F (-51°C to +204°C). The pressure rating is 285 psi (15.2 bar) at ambient temperature.

SERVICE

Representative stocks of 9RET and 9REL valves are maintained by Neles' network of authorized stocking distributors located in key industrial areas of the United States and Canada. They will be happy to assist in the selection of the most cost-effective valve for your application. For more information visit our website at www.neles.com.



DESCRIPTION – 9REL

The new *Jamesbury* 9REL low-profile flanged ball valve has been designed specifically for tank car applications. The valve has the same internals as the 9RET, but has a lower profile with a face-to-face dimension of only 4-3/4".

DESCRIPTION – 9RETS/9RELS

4" 9RETS and 9RELS valve has been specially engineered to overcome the major problem encountered in handling molten sulfur and similar materials – “freezing” caused by solidification within the valve. The valve is designed to resist the penetration of media into the normal clearances of the valve where it can solidify.

UNIQUE SEALING

The 9RETS and 9RELS ball valves for sulphur service are equipped with a special Barrier™ seat, consisting of a filled PTFE seat that is mechanically contained in an outer casing of 316 stainless steel. The drawing below illustrates the Barrier seat. (**Figure 1**) shows the seat contained in the outer casing and the ring seal. This combination of tackweld seat geometry and the ring seal produces a seat with a sealing zone on the back surface that prevents media from entering behind the seat, yet preserves the flexure of the seat.

The 9RETS valve is standard with a full steam jacket.

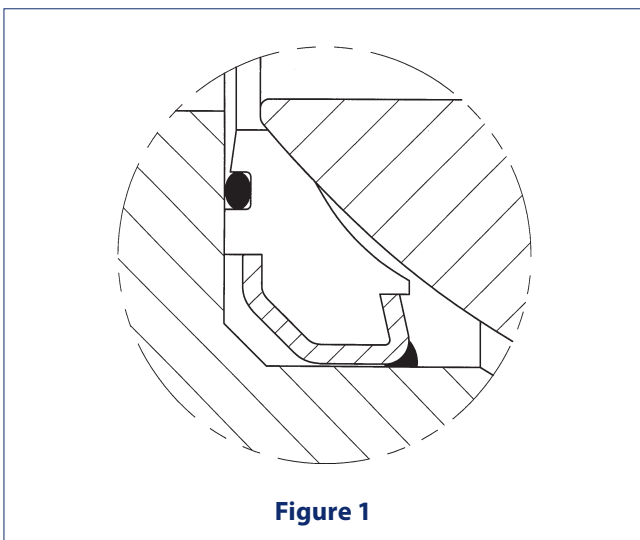

Figure 1

MATERIALS

9RETS and 9RELS valves are available in carbon steel with 316 stainless steel trim and all 316 stainless steel. Both standard with full steam jacket.

The new stem seal system consists of live-loaded v-ring packing, standard on all *Jamesbury* 9RET and 9REL Bov's.

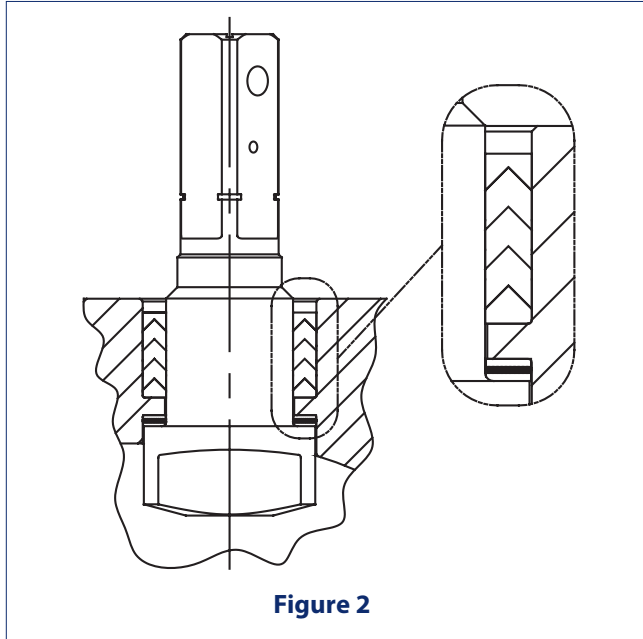
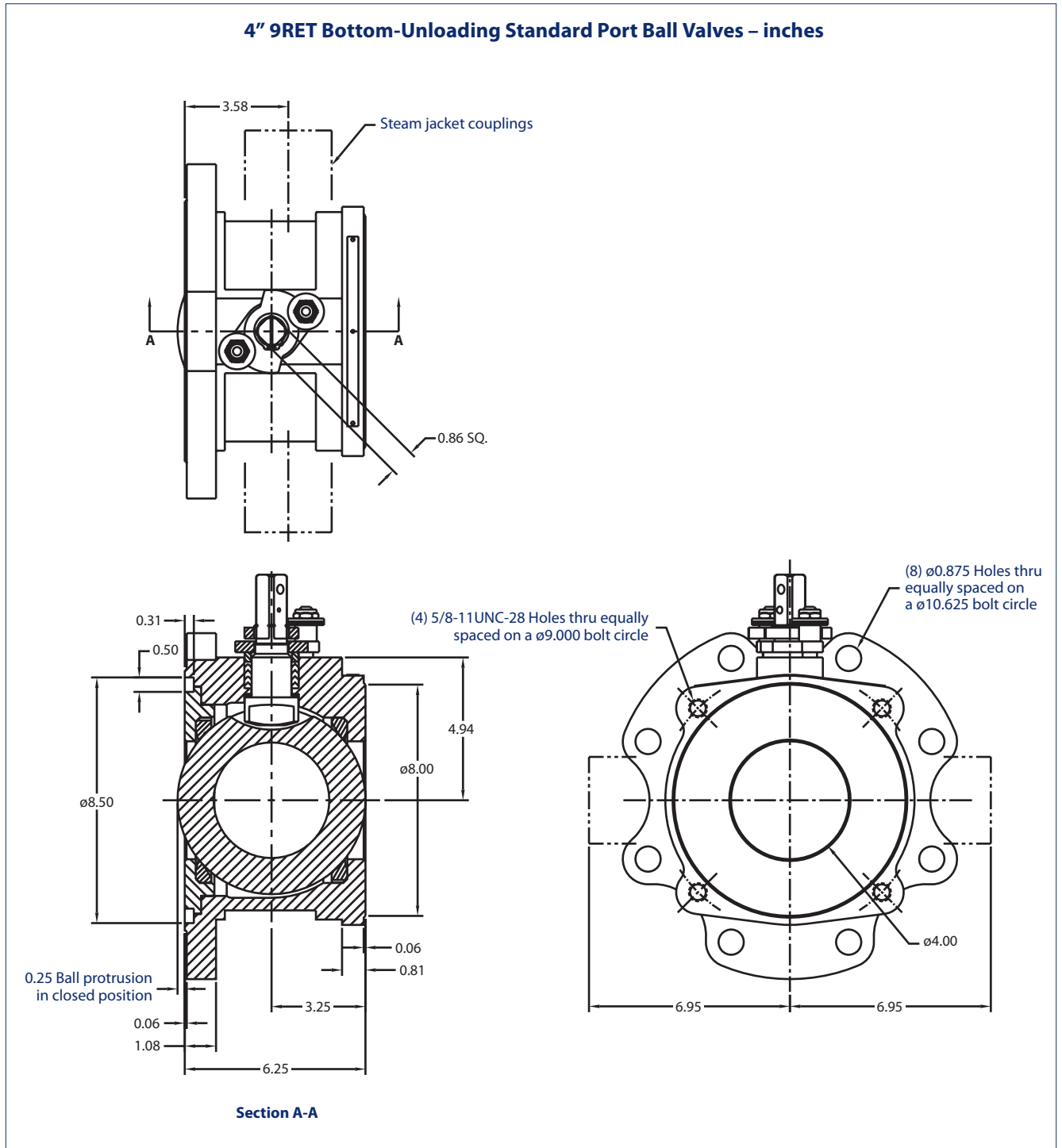

Figure 2

DIMENSIONS

4" 9RET Bottom-Unloading Standard Port Ball Valves – inches



DIMENSIONS

4" 9REL Low-Profile Bottom-Unloading Valves – inches

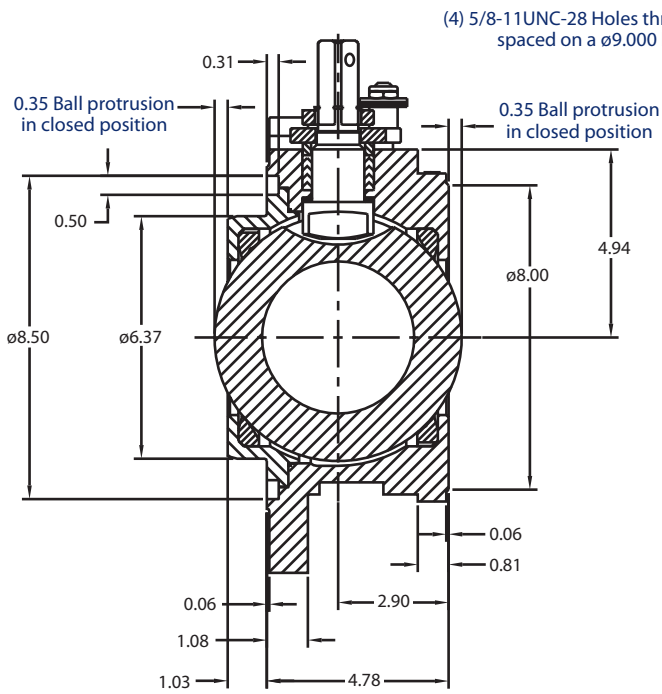
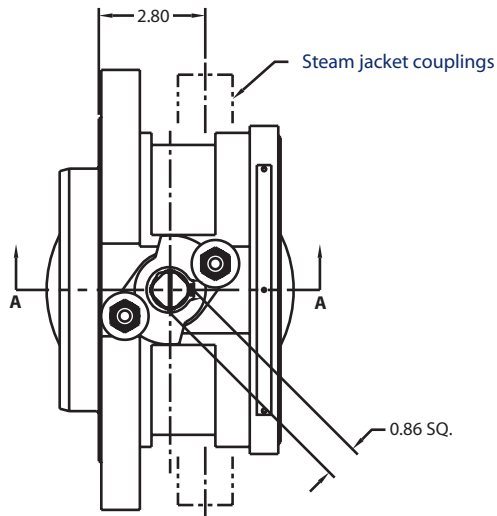

(4) 5/8-11UNC-28 Holes thru equally spaced on a $\phi 9.000$ bolt circle

(8) $\phi 0.875$ Holes thru equally spaced on a $\phi 10.625$ bolt circle

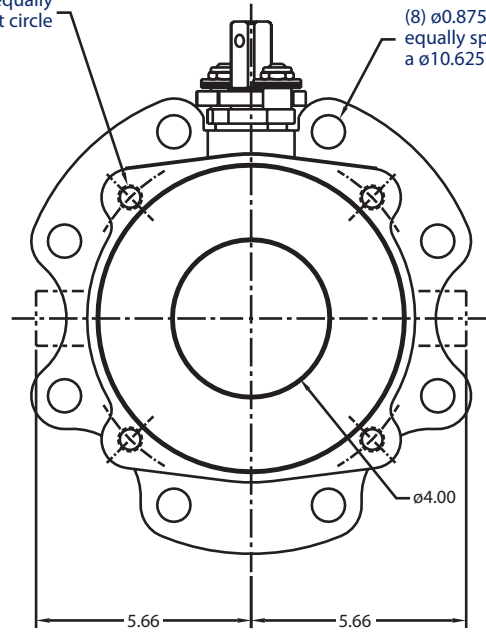

BILL OF MATERIALS AND PARTS LIST			
Part No.	Part Name	Body Material	
		Carbon Steel with 316 Stainless Steel Trim (22HB)	316 Stainless Steel (36HB)
1	Body	Carbon steel ASTM A216 Type WCB	316 Stainless steel ASTM A351 Type CF8M
2	Body Insert	Carbon steel	316 Stainless steel
3	Ball	316 Stainless steel	
4	Stem	17-4 PH Stainless steel	
5	Seat	PTFE or Xtreme® (Metal wrapped filled teflon) ¹	
6	Body Seal	PTFE	
7	Stem Seals	PTFE	
9	Bonnet Plate	Stainless steel	
10 ²	Locking Nut	Stainless steel	
11	Stem Bearing	PTFE	
12	Indicator Stop	Carbon steel	Stainless steel
13	Secondary Stem Seal	Graphite	
14	Stop Sleeve	Stainless Steel	
15*	Handle	Carbon Steel	
18	Compression Ring	Stainless steel	
20 ³	Socket Head Cap Screw	Stainless steel	
21	Pin	Stainless Steel	
25	O-Ring1	Viton	
26	Set Screw	Stainless steel	
28*	Handle Pin	Stainless Steel	
29	Identification Tag	Stainless steel	
31 ⁴	Pop Rivet	Stainless steel	
32	Retaining Ring	Stainless steel	

* Handle and pin supplied on request.
* Optional trim material offered upon request.
¹ Barrier™ seat design
² Part #10 on REL/RELS valves is an Elastic Stop Nut. Body material remains the same.
³ Part #20 on REL/RELS valves is a Body Insert Cap Screw. Body material remains the same.
⁴ Part #31 on REL/RELS valves is a Drive Screw. Body material remains the same.

HOW TO ORDER 9RET & 9RETS STANDARD PORT AND 9REL & 9RELS LOW-PROFILE VALVES

To specify Style 9RET & 9RETS Full-Port and 9REL & 9RELS Low-Profile, Bottom-Unloading Valves for Tank Car Applications, choose the appropriate code from each of the boxes shown at right.

EXAMPLE: The valve specified above is a 4" 9RET valve with standard construction and options, ASTM A216 body, 316 ball and 17-4 PH stem, and Xtreme seats and PTFE seals.

1	Size
4000	4"

2	Style
9RET	Full Bore, AAR Female Tongue / RR Raised Face, Standard Height, Bottom Outlet Valve
9REL	Full Port, AAR Female Tongue / RR Raised Face, Low Profile, Bottom Outlet Valve

3	Construction
3	Standard Construction
4	Steam Jacket Construction
5	Sulphur Service - Steam Jacket w/ Barrier Seats (Use MB Seats Only)

4	Body Materials
22	ASTM A216, Gr. WCB
36	ASTM A351, Gr. CF8M

1	2	3	4	5	6	7	8
0400	9RET	3	22	HB	XT	A	FO

5	Ball / Stem Material
HB	316 SS / 17-4 PH

6	Seat / Seal Material
TT	PTFE / PTFE
XT	Xtreme / PTFE
MB	MTFE - 316 - Viton / PTFE

7	Model
A	Model A

8	Word Modifiers (Optional Code)
FO	Counter-Clockwise to Close, Handle Rotation
-	Standard

Subject to change without prior notice. Neles, Jamesbury and Easyflow by Neles, and certain other trademarks, are either registered trademarks or trademarks of Neles Corporation or its subsidiaries or affiliates in the United States and/or in other countries. For more information www.neles.com/trademarks

Neles

Vanha Porvoontie 229, 01380 Vantaa, Finland.
Tel. +358 10 417 5000.

neles.com

Reinventing
reliability