

NELES

Jamesbury™ Value-Line™ 1/2", 3/4", 1", 1-1/2", 2" & 3" (DN 15, 20, 25, 40, 50 & 80) series 6FR full-bore threaded ball valves (AAR no. E182105)

The 6FR ball valve is a member of the Jamesbury™ Value-Line Series which offers the benefits of proven quality and design performance with exceptional economy not previously available in high-performance ball valves. Its full-bore configuration and high-pressure rating (1000 psi for 1/2" – 2" (DN 15 – 50), 800 psi for 3" (DN 80) make it an ideal choice for the majority of applications where tight shut-off is required.

FEATURES

Tight Shut-off

- The *Jamesbury* proven self-relieving seat design incorporates a flexible lip that automatically compensates for fluctuations in pressure and temperature.

Design

- Body cap tack-welded to body for superior integrity.

High Flow Capacity

- Full-bore design for maximum flow.

Anti-Blow-Out Stem

- Internal entry stem provides positive stem retention.

Fire-Tite™ Design

- All *Jamesbury* tank car ball valves are available with *Fire-Tite* design. In the event of a fire with resultant destruction of the PTFE seats, a secondary metal seating surface provides for continuing effective shutoff of flow through the valve.

Excellent Corrosion Resistance

- Available in all stainless steel construction.

SPECIFICATIONS

Valve Body Ratings

These are the maximum working pressure ratings of the valve body only. The seat ratings on page 2 determine the practical pressure limitation in actual service. Working pressure rating is at -20° F to +100° F (-29°C to +38°C)



for carbon steel and -60°F to +100°F (-51°C to +38°C) for stainless steel body materials.

Valve Size		Working Pressure	
inches	DN	psi	bar
1/2 – 2	15 – 50	1000	69
3	80	800	55

Flow Data

The table below provides flow coefficients for Series 6F valves. The C_v values represent the flow of water at +60°F (+17°C) through the valve in U.S. Gallons per minute at a pressure drop of 1 psi (bar).

Valve Size		C_v
Inches	DN	
1/2	15	13
3/4	20	40
1	25	65
1-1/2	40	135
2	50	251
3	80	1160

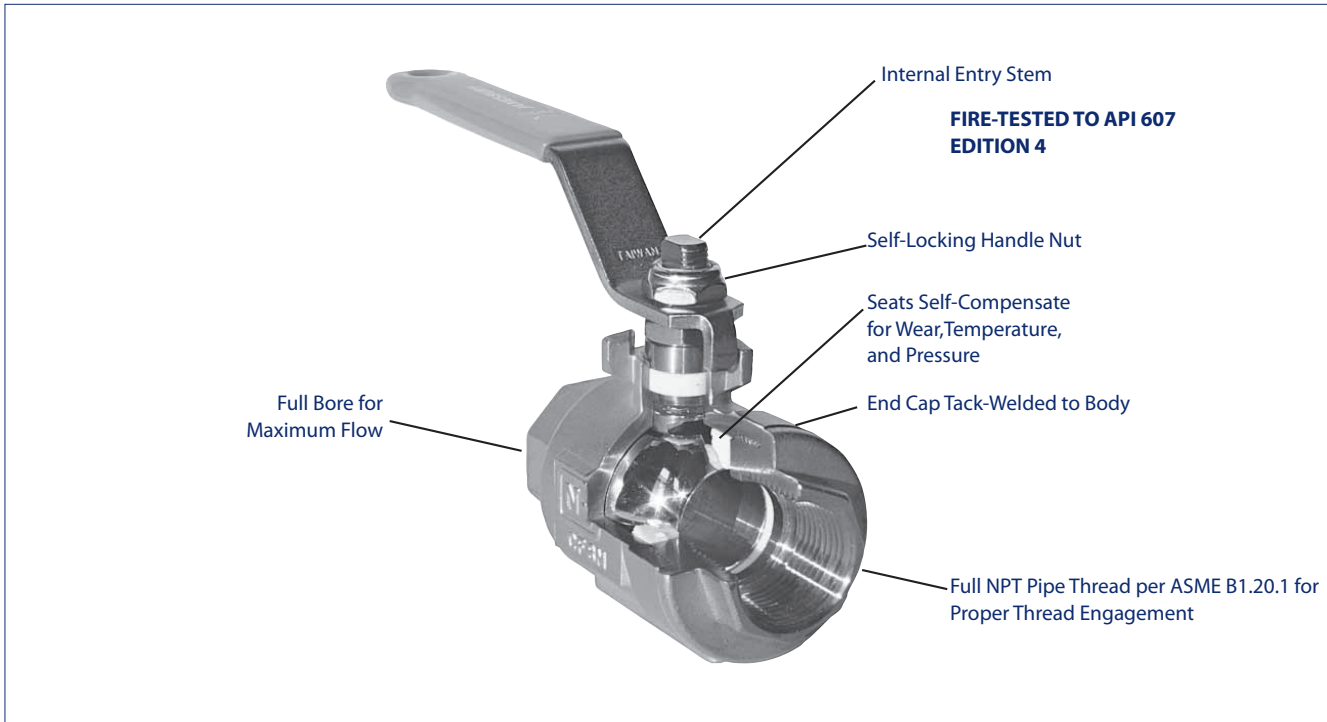

Valve Seat Ratings

These ratings, shown in the graph at right, are based on differential pressure with the valve ball in the fully closed position and refer to seats only. Valves in carbon steel are suitable for service to -20°F (-29°C); valves in stainless steel to -60°F (-51°C).

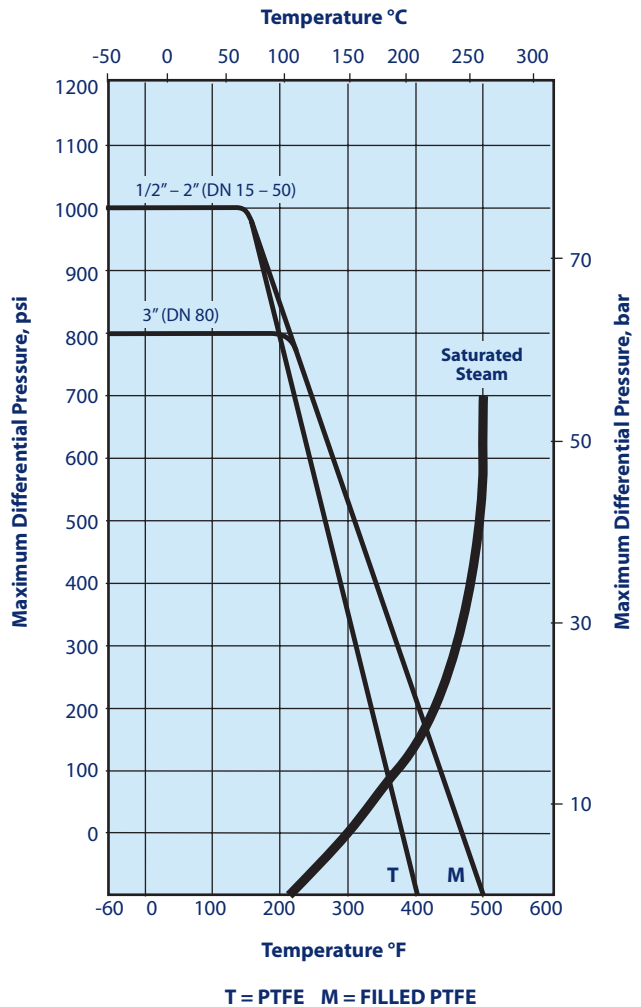

DIMENSIONS

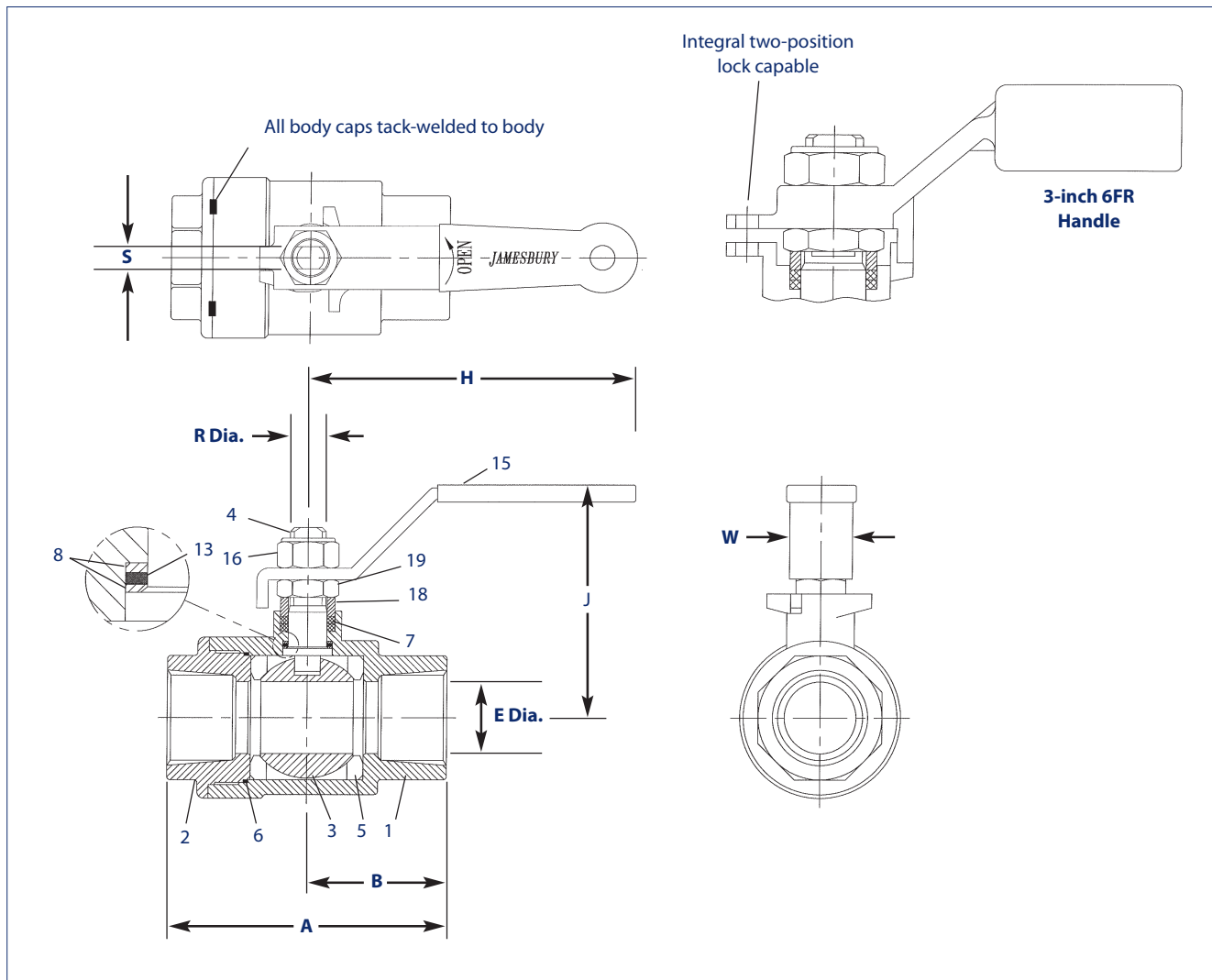

Valve Size inches	Approximate Dimensions - inches								Approx. Weight lb
	A	B	E	J	H	R	S	W	
1/2	2.57	1.18	0.50	2.20	4.00	0.31	0.18	0.75	0.75
3/4	3.38	1.58	0.88	3.00	5.50	0.50	0.31	0.88	2.1
1	3.76	1.81	1.00	3.13	5.50	0.50	0.31	0.88	2.7
1-1/2	4.77	2.28	1.50	4.02	6.00	0.63	0.37	0.98	5.6
2	5.04	2.52	2.00	4.61	6.00	0.63	0.37	0.98	8.7
3	7.36	3.68	2.99	6.14	6.00	1.00	0.67	1.05	28.0

Valve Size DN	Approximate Dimensions - mm								Approx. Weight kg
	A	B	E	J	H	R	S	W	
15	65	30	13	56	102	8	5	19	0.34
20	86	40	22	76	140	13	8	22	0.95
25	96	46	25	80	140	13	8	22	1.22
40	121	58	38	102	152	16	9	25	2.54
50	128	64	51	117	152	16	9	25	3.95
80	187	93	76	156	152	25	17	27	12.70

BILL OF MATERIALS AND PARTS LIST

Part Number	Quantity	Part Name	Carbon Steel	316 Stainless Steel
1	1	Body	A216-WCB - Carbon steel	A351-CF8M - Stainless steel
2	1	Body Cap	A216-WCB - Carbon steel	A351-CF8M - Stainless steel
3	1	Ball	316 Stainless steel	
4	1	Stem	316 Stainless steel	
5	2	Seal	PTFE/Filled PTFE	
6	1	Body Seal	Graphite	
7	2	Stem Seal	PTFE	
8	2	Stem Bearing	PTFE/Filled PTFE	
13	1	Secondary Stem Seal	Graphite	
15	1	Handle	Carbon steel	304 Stainless steel
16	1	Self Locking Stem Nut	304 Stainless steel	
18	1	Compression Ring	304 Stainless steel	
19	1	Packing Nut	304 Stainless steel	

WARNING:

As the use of the valve is application specific, a number of factors should be taken into account when selecting a valve for a given application. Therefore, some of the situations in which the valves are used are outside the scope of this manual. If you have any questions concerning the use, application or compatibility of the valve with the intended service, contact Neles for more information.

HOW TO ORDER SERIES 6FR BALL VALVES

To specify Series 6FR ball valves, choose the appropriate code from each of the boxes shown at right.

EXAMPLE: The valve specified is a 2" Series 6FR Full-bore threaded ball valve constructed of carbon steel body, 316 stainless steel ball and stem, and PTFE seats and seal.

1	2	3	4	5
2"	6FR	—	2236	TT C

1	Size
1/2	1/2" (DN 15)
3/4	3/4" (DN 20)
1	1" (DN 25)
1-1/2	1-1/2" (DN 40)
2	2" (DN 50)
3	3" (DN 80)

3	Body / Trim Material
2236	Carbon Steel Body / 316 Stainless Steel Trim
3600	316 Stainless Steel Body / Trim

4	Seat / Seal Material
TT	PTFE / PTFE*
MT	Filled PTFE / PTFE*

*With graphite secondary stem and body seal

2	Series
6FR	Series 6FR Full-bore Ball Valve

5	Model code
C	Serie 6FR Model C

Subject to change without prior notice. Neles, Jamesbury and Easyflow by Neles, and certain other trademarks, are either registered trademarks or trademarks of Neles Corporation or its subsidiaries or affiliates in the United States and/or in other countries. For more information www.neles.com/trademarks

Neles

Vanha Porvoontie 229, 01380 Vantaa, Finland.
Tel. +358 10 417 5000.

neles.com

Reinventing
reliability