

# NELES

## Jamesbury™ 2" (DN 50) 5RNT top-loading and unloading standard port angle ball valves for tank car applications (AAR no. E079030)

The 2" (DN 50) 5RNT angle ball valve is designed for top-loading and unloading of tank cars. Easy to install and to maintain, this type valve has proven to be reliable and give outstanding performance in a multi-tude of applications for over 30 years.

The 2" (DN 50) 5RNT ball valve offers the advantages of quick quarter-turn operation, long service life, and easy cycling. It is much faster to operate than multi-turn types of valves. In addition, it is easy to cycle even after being set in one position for an extended period.

### FEATURES

#### Unique Sealing

The superior performance of Jamesbury™ tank car ball valves is achieved by the unique design of the seat. The flexible-lip seats exert continuous sealing pressure on the ball. The seat automatically compensates for wear and for changes in temperature and pressure.

In addition, this valve is designed to withstand the demanding service requirements of the railroad industry.

#### Materials

5RNT valves are available in all 316 stainless steel. Other materials are available for special applications.

#### FIRE-TITE™ Design

All Jamesbury tank car ball valves have the Fire-Tite design. In the event of a fire resulting in partial or complete destruction of the PTFE seats, a secondary metal sealing surface provides continuous effective shutoff.



### SPECIFICATIONS

#### Flow Data

The 2" (DN 50) 5RNT valve has an installed CV value of 70. CV is defined as the flow of water through the valve in U.S. gallons per minute at a pressure drop of 1 psi. The metric equivalent, KV, is the flow of water at 16°C through the valve in cubic meters per hour at a pressure drop of 1 kg/cm<sup>2</sup>. To convert CV to KV, multiply by 0.8569. This CV value is an estimate of the installed flow capacity and considers typical inlet losses.

#### Ratings

5RNT valves are rated for pressures and temperatures well in excess of those that are normally encountered in tank car service. Carbon steel valves are rated from -20°F to +500°F (-29°C to +260°C). 316 stainless-steel valves are rated from -60°F to +500°F (-51°C to +260°C). The pressure rating is 600 psi (41 bar) at ambient temperature.

#### Service

Representative stocks of 5RNT valves are maintained by the Neles network of authorized stocking distributors located in key areas of the United States and Canada. They will be happy to assist you in the selection of the most cost-effective valve for your application. For the distributor, visit our web site at [www.neles.com](http://www.neles.com).

**DIMENSIONS**

**2" (DN 50) 5RNT Top-Loading and Unloading Standard-Port Angle Ball Valves inches (mm)**

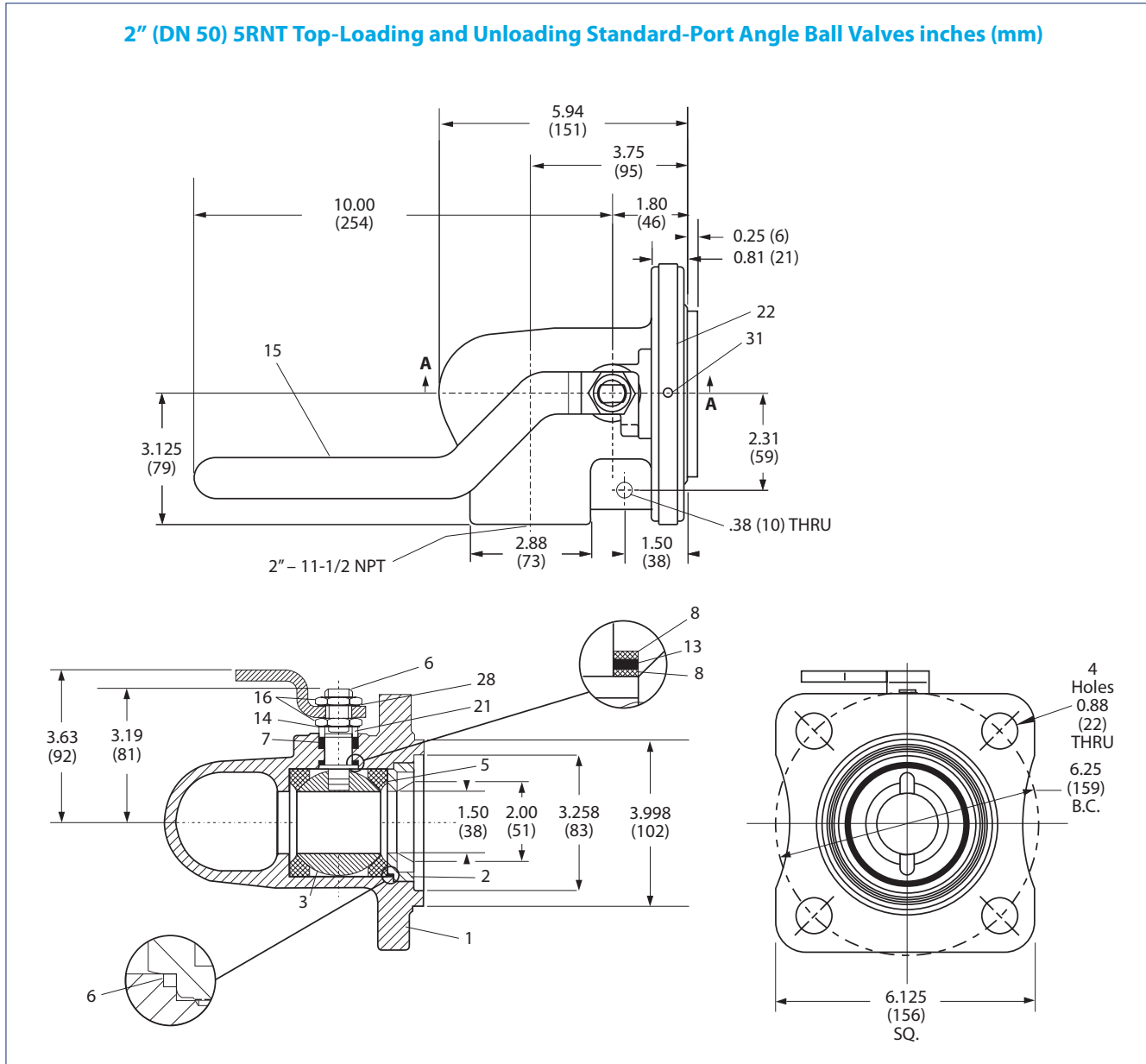

BILL OF MATERIALS AND PARTS LIST		
Part No.	Part Name	Body Material
		316 Stainless Steel (36HB)
1	Body	316 Stainless steel ASTM A351 Type CF8M
2	Body Insert	316 Stainless steel flash chrome plated
3	Ball*	316 Stainless steel
4	Stem*	316 Stainless steel hard chrome plated
5	Seat	PTFE or XTREME™
6	Body Seal	PTFE
7	Stem Seal	PTFE or TFM
8	Stem Bearing	Filled PTFE
13	Secondary Stem Seal	Graphite
14	Stem Washer	Stainless steel
15	Handle†	Carbon steel
16	Stem Nut	Stainless steel
21	Compression Ring	Stainless steel
22	Identification Tag	Stainless steel
28	Shakeproof Washer	Stainless steel

\* Optional trim material offered upon request.

† Handle options available. See IMO-R13.

## HOW TO ORDER 5RNT BALL VALVES

To specify one of these valves, it is necessary only to select the proper body material to meet a particular service requirement. All other components are of materials appropriate for the most severe conditions.

The catalog designations below fully describe a valve, identifying body, trim, seat, and seal materials. The codes are:

### **316 Stainless steel body and trim:**

#### **2" 5RNT-3600 TT**

For XTREME seats, simply substitute XT for TT.

To order a Service Kit for these valves, specify RKR48 TT or MT.

Subject to change without prior notice. Neles, Jamesbury and Easyflow by Neles, and certain other trademarks, are either registered trademarks or trademarks of Neles Corporation or its subsidiaries or affiliates in the United States and/or in other countries. For more information [www.neles.com/trademarks](http://www.neles.com/trademarks)

# Neles

Vanha Porvoontie 229, 01380 Vantaa, Finland.  
Tel. +358 10 417 5000.

[neles.com](http://neles.com)

Reinventing  
reliability