

NELES

2"- 12" (DN 50-300) side ported Jamesbury™ 3-way flanged ball valves

Jamesbury 3-way ball valves are extremely versatile units of rugged design for diverting or blending flow in a variety of gases or liquids. Important savings result from the fact that one 3-way valve does the work of two or even three conventional valves.

Equipped with a ball having a right angle port which connects either end port with the side port of the valve, they can be used for diversion of flow entering the side port to either end port, or for mixing or blending when there is flow of different fluids into the end ports and out the side port. Just one 3-way valve can control a by-pass or recirculation system, or direct flow out of or into different storage tanks (see **Figure 1**).

Available in 2" – 12" (DN 50 – 300) sizes, these valves are designed for Class 150 service. They are rated for a maximum differential pressure of 275 psi (19 bar), and for temperatures from -40°F to +300°F (-40°C to 149°C) depending on size and material. Standard materials include carbon steel with 316 stainless steel trim or all 316 stainless steel. Valves in other materials, flange designs and waterway configurations are available on application.

Class 150 3-way valves in sizes 2" – 4" (DN 50 – 100) have the designation AM150FD. Valves in sizes 6" – 12" (DN 150 – 300) are designated as DM150FD.

FEATURES

Bidirectional Flow

- Handles flow into the end ports and out of the common side port for mixing applications, or into the side port and out of either end port for diverting applications.

Effective Stem Sealing

- "Corner Sealing," the compression of low friction PTFE box rings, eliminates stem leakage by avoiding straightline leakage paths.

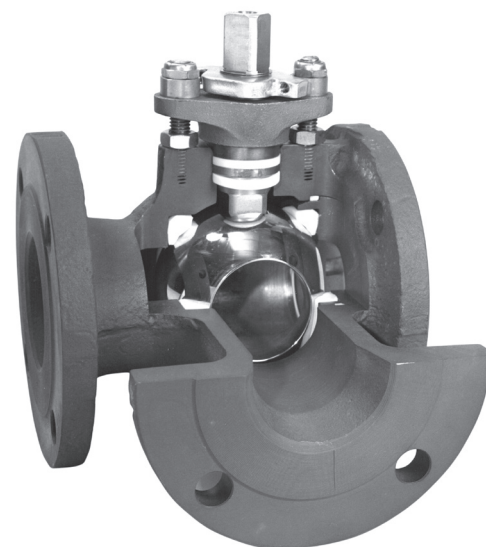
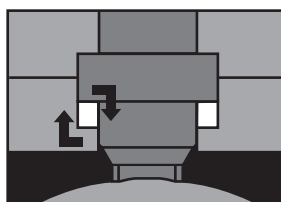
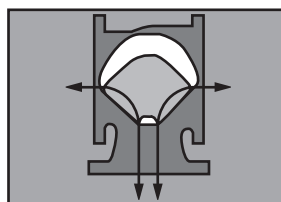

- Stem seal adjustment, if ever required, is done by simply tightening bonnet screws or bolts.

Economical

- One 3-way valve does the work of two or three conventional valves.
- Lowers the investment in valves, flanges, intermediate piping, actuators, installation labor, and circuit requirements.

Single Piece Body

- A unit body design in sizes 2" – 10" (DN 50 – 250) provides high structural strength, assures overall piping rigidity, and minimizes potential leak paths.

Easy Automation

- For automatic valve operation, any of these 3-way valves may be ordered with a *Jamesbury* pneumatic or electric actuator, providing single source responsibility.
- Each valve is manufactured with its bonnet surface machined and tapped to permit rigid, positively aligned field mounting of an actuator directly onto the valve.

APPLICATION

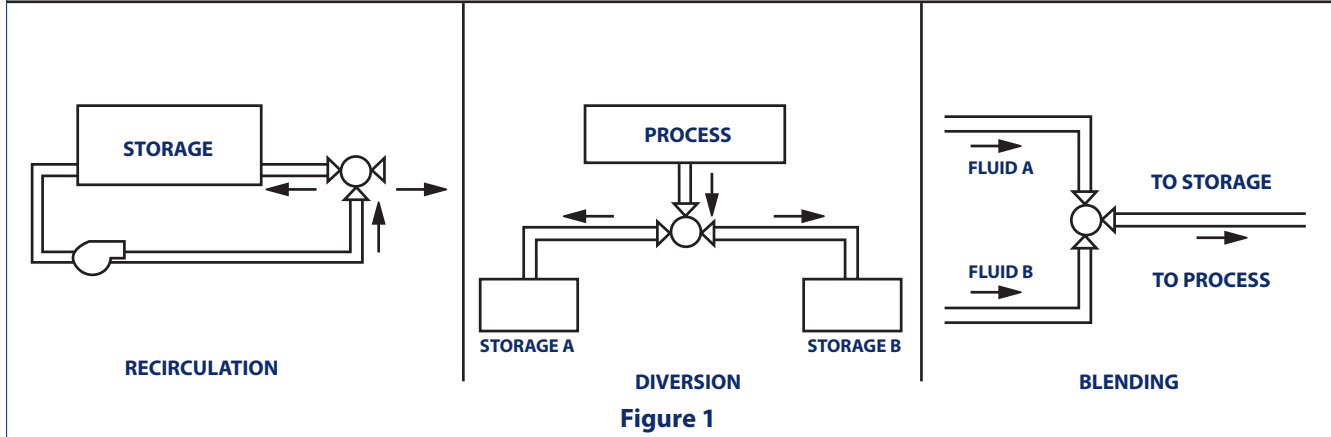
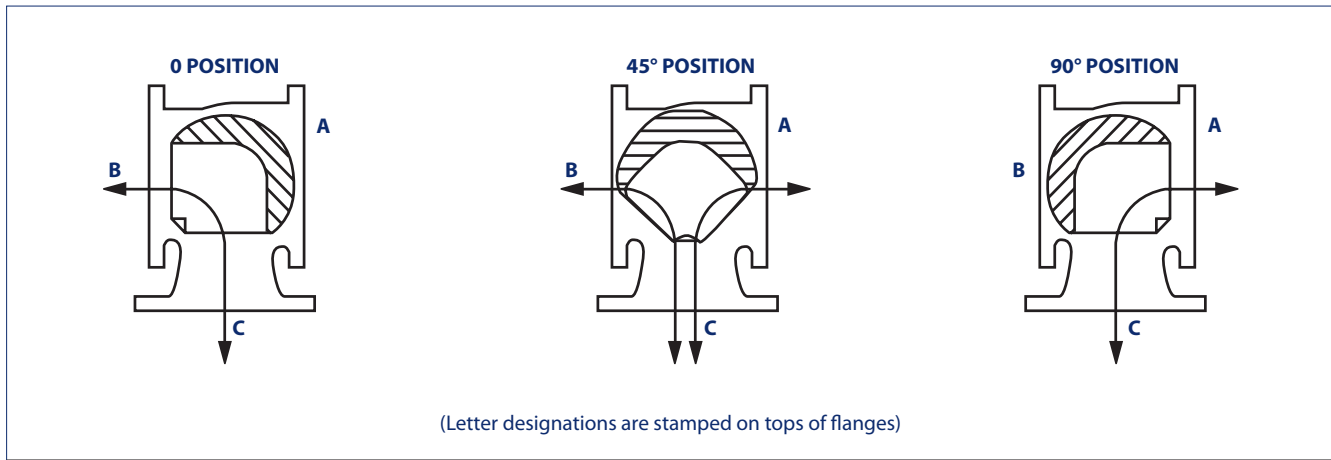
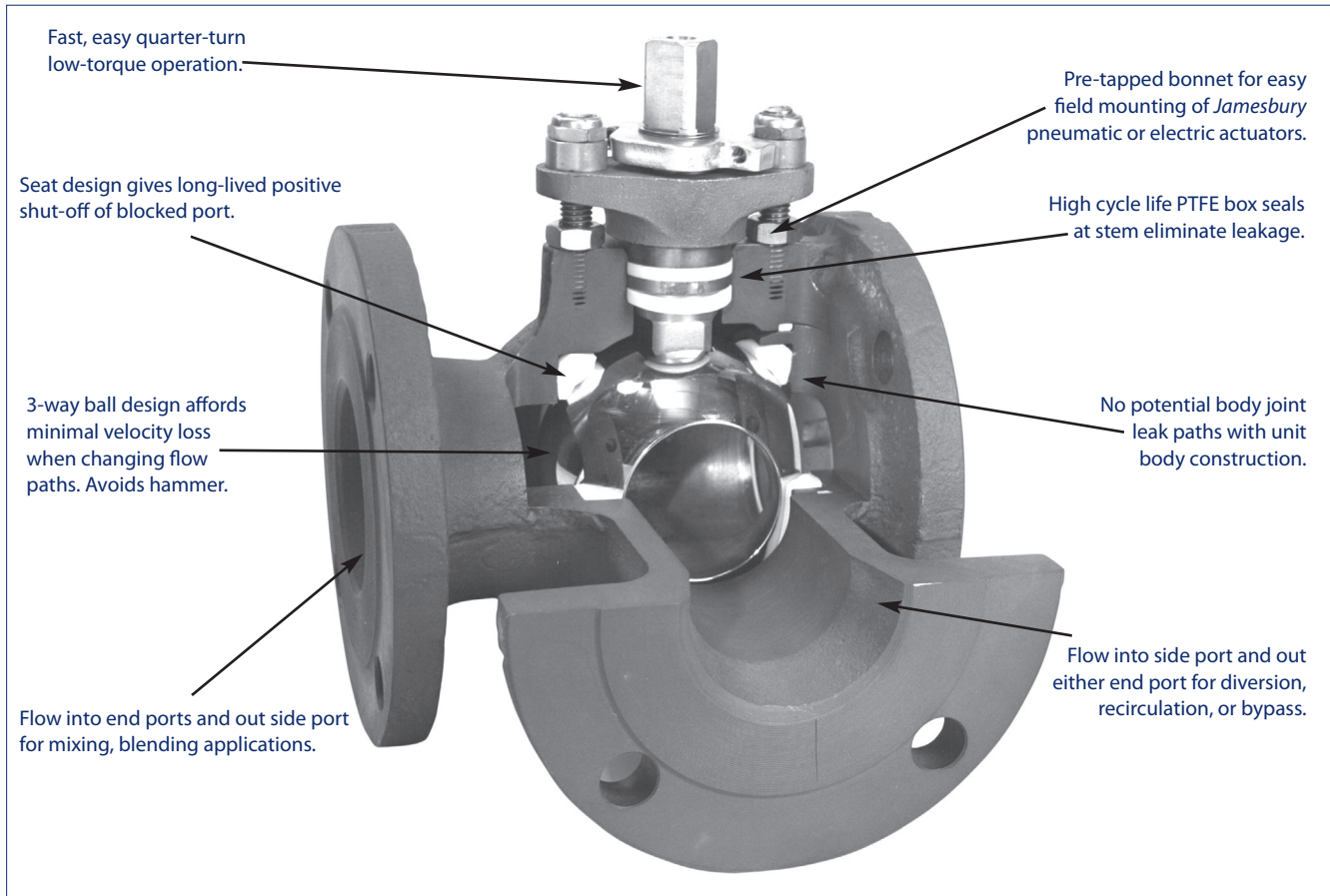

SPECIFICATIONS

Valve Body Ratings

These are maximum working pressure ratings of the **valve body only**. The seat ratings shown in **Figure 2** below, determine the practical pressure limitations according to actual service conditions. Test pressures are for hydrostatic test with ball half open.

Temperature °F	Carbon Steel psi	316 Stainless Steel psi
-20 to 100	285	275
200	260	235
300	230	215
400	200	195
500	170	170
Test Pressure	450	425

Temperature °C	Carbon Steel bar	316 Stainless Steel bar
-29 to +38	19.6	19.0
100	17.7	16.2
150	15.8	14.8
200	13.8	13.7
250	12.1	12.1
Test Pressure	30	29

Flow Data

The table below provides friction loss information on 3- way valves. The C_v values represent the flow of water at +60°F through the valve in U.S. gallons per minute at a pressure drop of 1 psi. The metric equivalent, K_v , is the flow of water at 16°C through the valve in cubic meters per hour at a pressure drop of 1 kg/cm². To convert C_v to K_v , multiply by 0.8569. Values are for flow through either end port or through the common side port.

Valve Size		C_v
inches	DN	
2	50	50
3	80	155
4	100	270
6	150	440

Valve Size		C_v
inches	DN	
8	200	880
10	250	1500
12	300	2300

VALVE SEAT RATINGS

Seat ratings, indicated by solid lines in the charts, are based on differential pressure with the valve ball in the fully closed position and refer to seats only. Maximum

working pressures for Class 150 steel valve bodies are shown in the tables on the previous page.

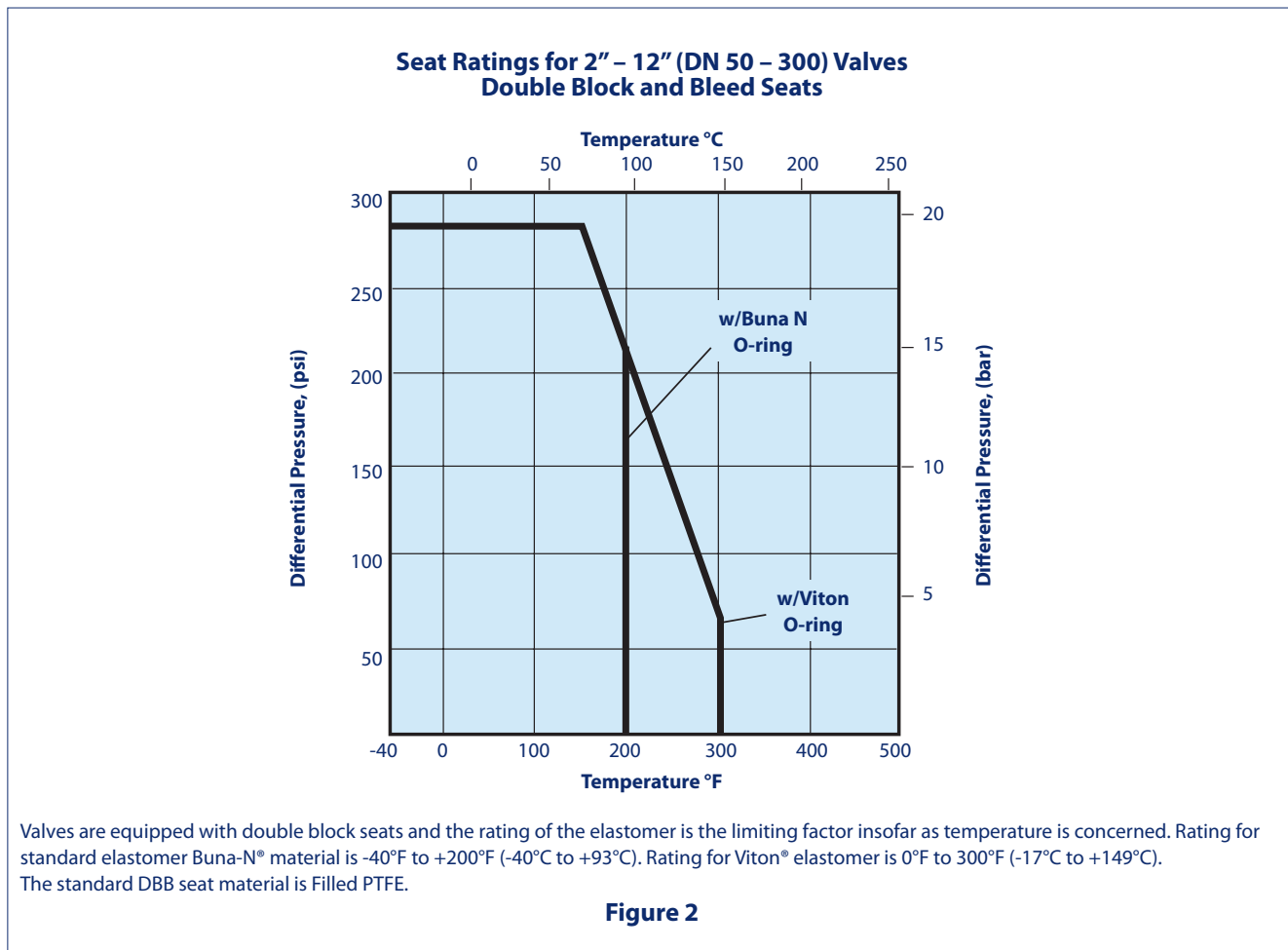

DIMENSIONS

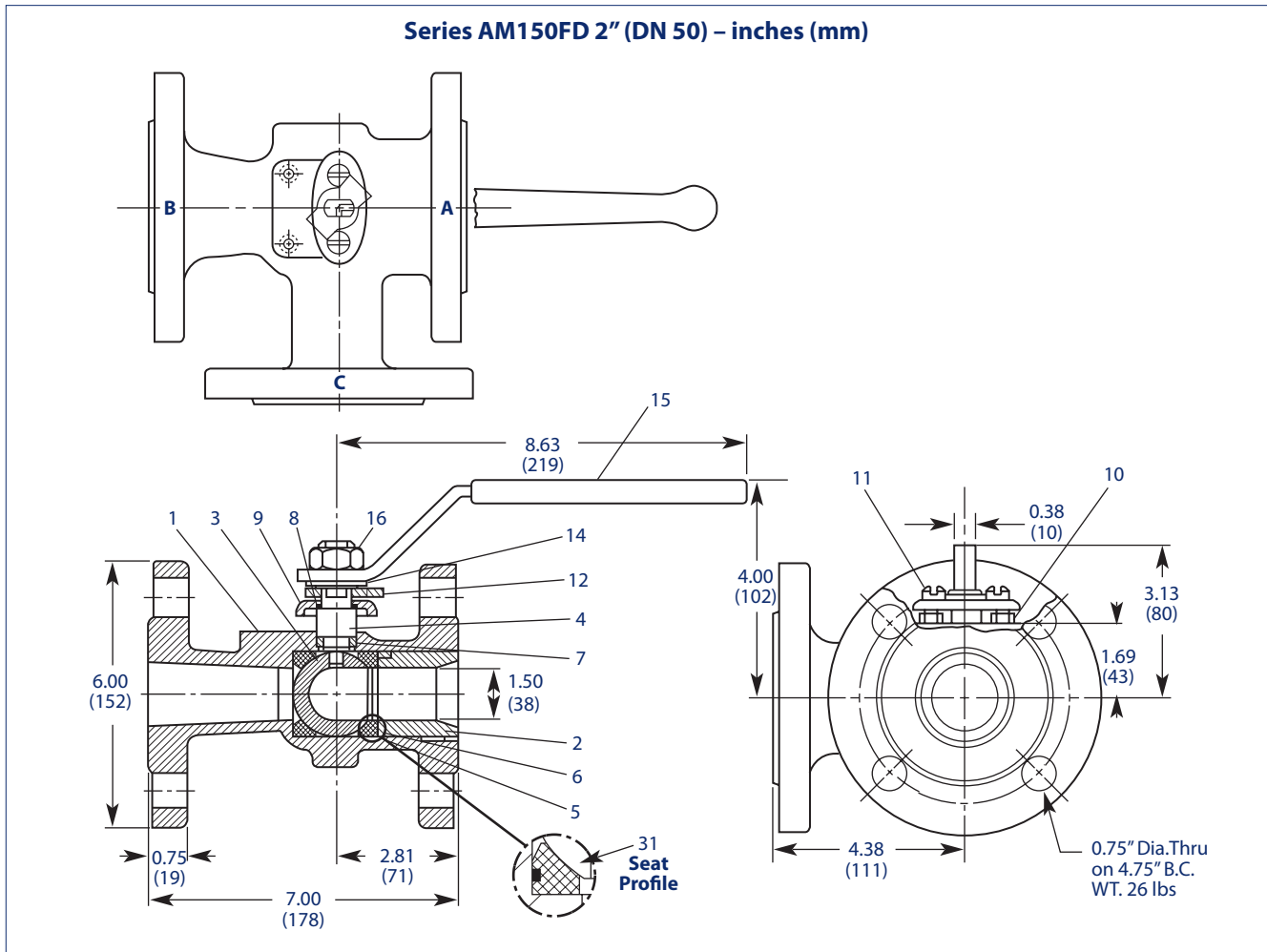

BILLS OF MATERIALS AND PARTS LIST			
2" (DN 50) AM150FD			
Part No.	Part Name	Body Material	
		Carbon steel (22)	316 Stainless steel (36)
1	Body	Carbon steel ASTM A216 Type WCB	316 Stainless steel ASTM A351 Type CF8M
2	Insert	Carbon steel	316 Stainless steel Flash Chrome Plated
3	Ball	316 Stainless steel	
4	Stem	316 Stainless steel – Hard Chrome Plated	
5	Seat	Elastomer Backed Filled PTFE	
6	Body Seal	PTFE	
7	Stem Seal	PTFE	
8	Stem Bearing	Nylon	
9	Bonnet Plate	302 Stainless steel	
10	Hex Nut	Carbon steel	
11	Bonnet Screw	300 Series Stainless steel	
12	Indicator Stop	302 Stainless steel	
14	Retaining Ring	Carbon steel	
15	Handle	Carbon steel	
16	Stem Nut	Carbon steel	

DIMENSIONS

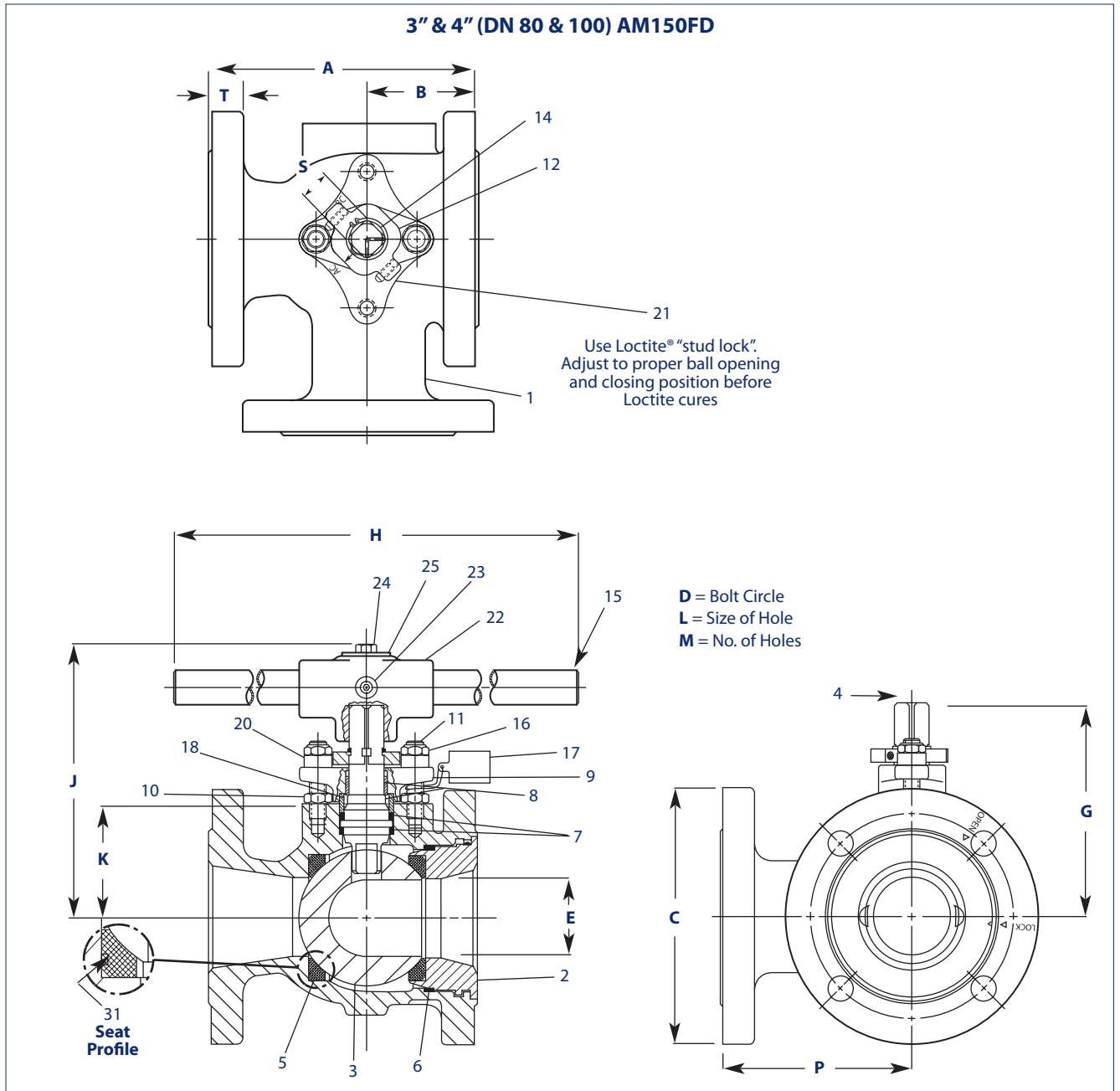

Approximate Dimensions - inches															
Valve Size inches	A	B	C	D	E	G	H	J	K	L	M	P	S	T	Approx. Weight lbs
3	8.00	3.25	7.50	6.00	2.31	6.25	21.50	8.25	3.38	0.75	4.00	5.75	0.88	0.75	74
4	9.00	4.00	9.00	7.50	3.13	6.88	21.50	8.88	4.00	0.75	8.00	6.50	0.88	0.94	95

Approximate Dimensions - mm															
Valve Size DN	A	B	C	D	E	G	H	J	K	L	M	P	S	T	Approx. Weight kg
80	203	83	191	152	59	159	546	210	86	19	4	146	22	19	34
100	229	102	229	191	80	175	546	226	102	19	8	165	22	24	43

BILLS OF MATERIALS AND PARTS LIST			
3" & 4" (DN 80 & 100) AM150			
Part No.	Part Name	Body Material	
		Carbon steel (22)	316 Stainless steel (36)
1	Body	Carbon steel ASTM A216 Type WCB	316 Stainless steel ASTM A351 Type CF8M
2	Insert	Carbon steel ASTM A216 Type WCB	316 Stainless steel ASTM A351 Type CF8M
3	Ball	316 Stainless steel	
4	Stem	316 Stainless steel	
5	Seat	Elastomer Backed Filled PTFE	
6	Body Seal	PTFE	
7	Stem Seal	PTFE	
8	Stem Bearing	Filled PTFE	
9	Compression Plate	Carbon steel	Stainless steel
10	Hex Jam Nut	Carbon steel	
11	Bonnet Stud	300 Series Stainless steel	
12	Indicator Stop	Carbon steel	Stainless steel
14	Retaining Ring	300 Series Stainless steel	
15	Handle	Carbon steel	
16	Stop Nut	300 Series Stainless steel	
17	Identification Tag	300 Series Stainless steel	
18	Compression Ring	300 Series Stainless steel	
20	Spacer	300 Series Stainless steel	
21	Set Screw	300 Series Stainless steel	
22	"T" Handle Adapter	Malleable Iron	
23	Set Screw	300 Series Stainless steel	
24	Stem Screw	Carbon steel	
25	Washer	Carbon steel	
31	O-Ring	Buna-N,Viton A (as specified)	

DIMENSIONS

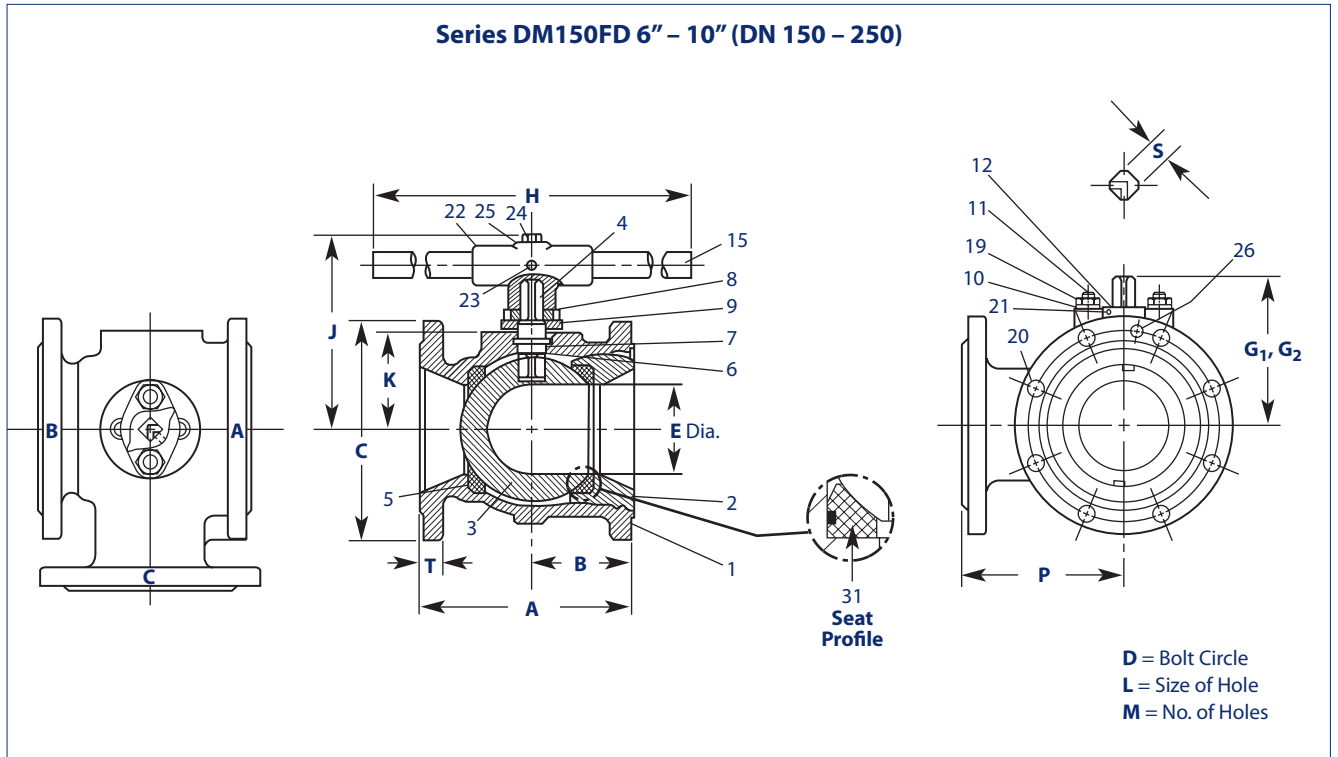

Valve Size inches	Approximate Dimensions – inches															Approx. Weight lbs
	A	B	C	D	E	G ₁ *	G ₂ *	H	J	K	L	M	P	S	T	
6	10.50	5.00	11.00	9.50	4.50	7.50	9.44	30.00	9.81	4.88	0.88	8	8.00	1.00	1.06	168
8	11.50	5.75	13.50	11.75	6.00	8.69	10.69	30.00	11.13	6.19	0.88	8	9.75	1.00	1.19	265
10	13.00	6.50	16.00	14.75	7.38	10.44	12.25	72.00	13.31	7.50	1.00	12	13.00	1.31	1.25	520

Valve Size DN	Approximate Dimensions – mm															Approx. Weight kg
	A	B	C	D	E	G ₁ *	G ₂ *	H	J	K	L	M	P	S	T	
150	267	127	279	241	114	191	240	762	249	124	22	8	203	25	27	76
200	146	146	343	298	152	221	272	762	283	157	22	8	248	25	30	120
250	330	165	406	362	187	265	311	1829	338	197	25	12	331	33	32	236

* Dimension G₁ is for manually operated valve. Dimension G₂ is for valve to be equipped with an actuator.

BILLS OF MATERIALS AND PARTS LIST			
6" - 10" (DN 150 - 250) DM150FD			
Part No.	Part Name	Body Material	
		Carbon steel (22)	316 Stainless steel (36)
1	Body	Carbon steel ASTM A216 Type WCB	316 Stainless steel ASTM A351 Type CF8M
2	Insert	Carbon steel ASTM A216 Type WCB	316 Stainless steel ASTM A351 Type CF8M
3	Ball	316 Stainless steel	
4	Stem	316 Stainless steel	
5	Seat	Elastomer Backed Filled PTFE	
6	Body Seal	PTFE	
7	Stem Seal	PTFE	
8	Stem Bearing	Filled PTFE	
9	Bonnet Plate	Carbon steel	Stainless steel
10	Hex Jam Nut	Carbon steel	
11	Bonnet Stud or Cap Screw	300 Series Stainless steel	
12	Indicator Stop	Carbon steel	Stainless steel
15	Handle	Carbon steel	
17	Identification Tag	300 Series Stainless steel	
19	Lockwasher	300 Series Stainless steel	
21	Set Screw	300 Series Stainless steel	
22	"T" Handle Adapter	Malleable Iron	
23	Set Screw	300 Series Stainless steel	
24	Stem Screw	Carbon steel	
25	Washer	Carbon steel	
26	Roll Pin	300 Series Stainless steel	
31	O-Ring	Buna-N,Viton A (as specified)	

DIMENSIONS

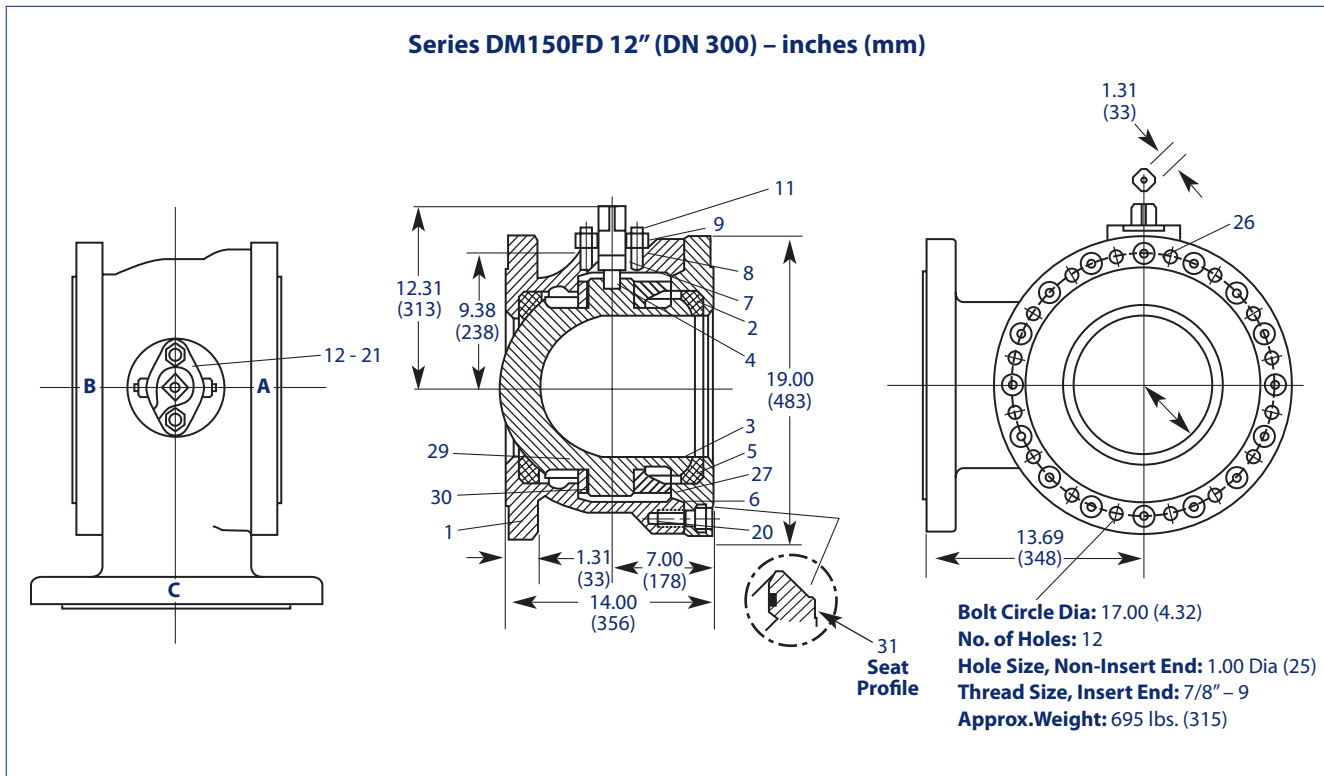

BILLS OF MATERIALS AND PARTS LIST – 12" (DN 300) Valves			
Part No.	Part Name	Body Material	
		Carbon steel (22)	316 Stainless steel (36)
1	Body	Carbon steel ASTM A216 Type WCB	316 Stainless steel ASTM A351 Type CF8M
2	Insert 3" – 10" (DN 80 – 250) Body Cap 12" (DN 300)	Carbon steel	316 Stainless steel
3	Ball	316 Stainless Steel	
4	Stem	316 Stainless Steel – Hard Chrome Plated (3" – 10" [DN 80 – 250]) 17-4 PH Stainless steel (12" [DN 300])	
5	Seat	Elastomer Backed Filled PTFE	
6	Body Seal	PTFE	
7	Stem Seal	PTFE	
8	Stem Bearing 3", 4", 10", 12" (DN 80, 100, 250, 300)	Filled PTFE	
9	Bonnet Plate	Carbon steel	Stainless steel
10	Hex Nut 3" – 4" (DN 80 – 100)	Carbon steel	
11	Bonnet Stud or Screw	300 Series Stainless steel	
14	Retaining Ring 3"– 4" (DN 80 – 100)	300 Series Stainless steel	
16	Bonnet Nut 3" – 4" (DN 80 – 100)	300 Series Stainless steel	
18	Compression Ring 3"– 4"(DN 80 – 100)	300 Series Stainless steel	
20	Spacer 3" – 4" (DN 80 – 100)	300 Series Stainless steel	
24	Stem Screw	Carbon steel	
26	Roll Pin 12" (DN 300) only	300 Series Stainless steel	
27	Trunnion Plate 12" (DN 300) only	Carbon steel	316 Stainless steel
29	Trunnion Bearings 12"(DN 300) only	Other Materials Available On Application	
30	Trunnion Thrust Bearing 12"(DN 300)	Filled PTFE - Metal Backed Filled PTFE	
31	O-Ring	Buna-N or Viton (as specified)	

VALVE TORQUE DATA

These torque charts for valves equipped with filled PTFE Double Block and Bleed seats are to be used as a guide for actuator selection. **Note:** with these 3-way valves, differential pressure will exist only when one of the side ports is blocked. An actuator should be selected that provides the same or greater torque output than that shown in the chart below. Refer to bulletins on *Jamesbury* pneumatic and electric actuators for torque output values and actuator selection tables.

Additional requirements may be imposed by media characteristics, trim, and frequency of valve operation. For clean lubricating fluid service, required torque may be reduced 33% when the valve is equipped with corrosion resistant trim. For difficult services (slurries, semi-solids) increase values by 50%. If in doubt, select the next larger actuator.

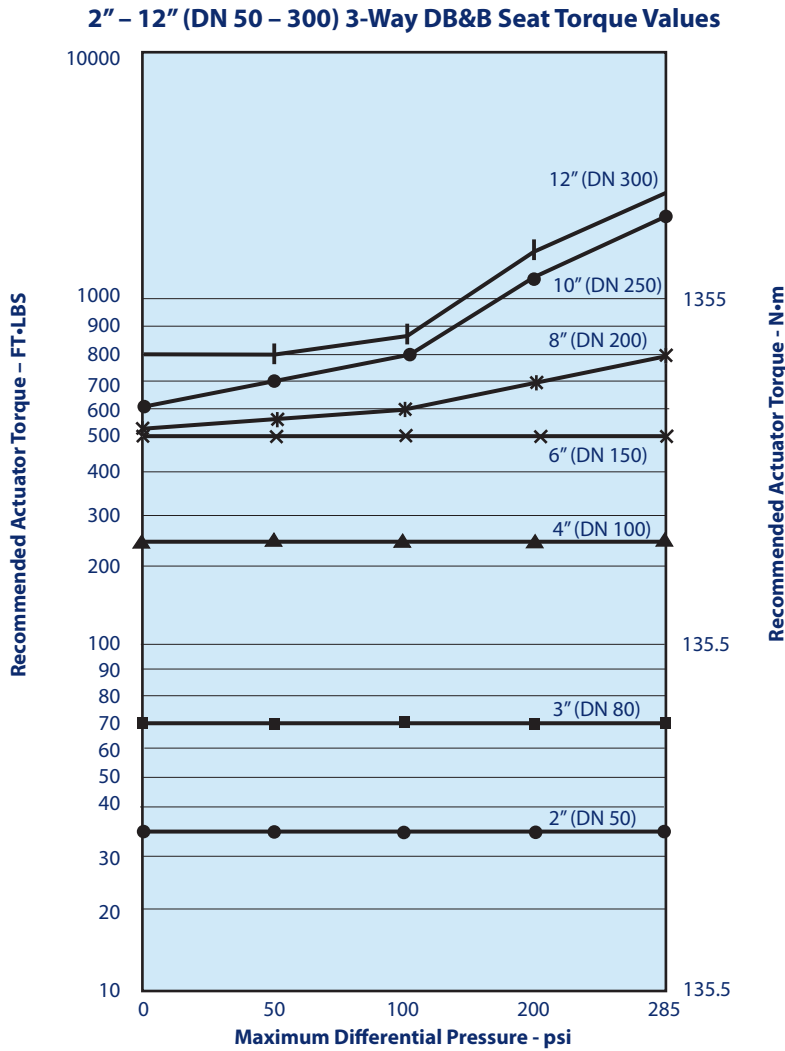

ACTUATORS

Pneumatic actuators that include both double-acting and spring-return types are available for all valves. Electric actuators are available in both watertight and hazardous location models.

For description of actuator types, see the following bulletins:

Actuator	Bulletin
Manual Gear Actuators	A100-1
Spring Diaphragm Rotary Actuators	A110-4
VPVL Rack & Pinion Actuators	A111-5
V-Series Electric Actuators	V200-1
ADC-Series Electric Actuators	V201-1
I-Series Electric Actuators	V206-1
QX-Series Electric Actuators	V207-1

WARNING:

As the use of the valve is application specific, a number of factors should be taken into account when selecting a valve for a given application. Therefore, some of the situations in which the valves are used are outside the scope of this manual. If you have any questions concerning the use, application or compatibility of the valve with the intended service, contact Neles for more information.

HOW TO ORDER

To specify a *Jamesbury* 3-way valve it is necessary only to determine the size and material required for a particular service. Then make a selection from each of the categories below to complete the proper catalog code.

EXAMPLE: (Code in Parenthesis)

4" Class 150 3-way flanged valve (AM150) w/Double Block and Bleed Seats, Carbon Steel Body (22), 316 stainless steel trim (36), filled PTFE seats (M), PTFE seals (T) and Buna-N O-Rings (52) is written: 4" AM150FDDBB2236MT52.

1	2	3	4	5	6	7	8	9		
4"	—	AM	150	FD	DBB	—	2236	M	T	52

1	Size						
inches	2	3	4	6	8	10	12
DN	50	80	100	150	200	250	300

2	Body Style inches (DN)	
AM	2" – 4" (DN 50 – 100)	
DM	6" – 12" (DN 150 – 300)	

3	Body Rating
150	Class 150

4	Configuration
FD	Side ported flanged body

5	Configuration
DBB	Double Block and Bleed Seat

6	Body/Trim Material
2236	Carbon steel body/316 stainless steel trim
3600	316 Stainless steel body/316 stainless steel trim

7	Seat Material
M	Filled PTFE

8	Seal Material
T	PTFE

9	O-Ring / Stem Selection
2" thru 10"	
52	Buna N
53	Viton
6" thru 12"	
AO	Buna N with operating stem
DO	Viton with operating stem

Neles

Vanha Porvoontie 229, 01380 Vantaa, Finland.
Tel. +358 10 417 5000.

neles.com

B114-1EN - 11/2020

Subject to change without prior notice. Neles, Jamesbury and Easyflow by Neles, and certain other trademarks, are either registered trademarks or trademarks of Neles Corporation or its subsidiaries or affiliates in the United States and/or in other countries. For more information www.neles.com/trademarks

Reinventing
reliability