

Cast iron
16K

Type RPF13 Lift Safety Relief Valves

4

Safety Relief Valves

Features

- Lift type safety relief valve with cast iron body
- Stable operation



With lever opened

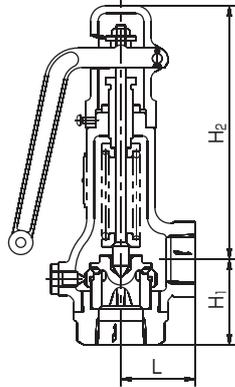

With lever opened



Non-lever

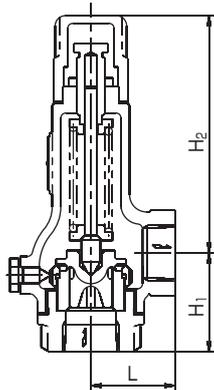

Non-lever closed

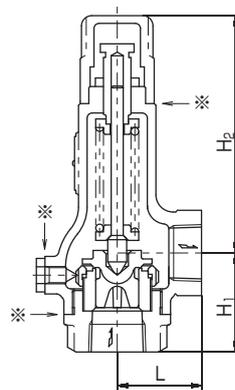

Non-lever opened

※Without gasket

Specifications

Spring case form	Non-lever opened	With lever opened	Non-lever closed	Non-lever closed	
Fluid	Steam, gas			Water	
Pressure	Set : 0.02 – 1.6 MPa (back pressure : atmospheric)			0.02 – 1.0MPa	
Temperature	0 – 220°C		0 – 200°C	0 – saturated temp.	
Material	Body	Cast iron		Cast iron	
	Valve seat	Stainless steel		Stainless steel stellited	
	Valve disc	Stainless steel		Stainless steel stellited	
	Stem	Stainless steel		Stainless steel	
	Spring case	Cast iron		Cast iron	
	Adjusting spring	Spring wire, piano wire		Spring wire, piano wire	
	Lever	—	Cast iron	—	—
	Cover	Cast iron		Cast iron	
	Adjusting ring	Brass		Brass	
Use for	Pressure vessel, header, outlet of PRV, thermal relief and piping protection				

Dimensions and weights

(mm, kg)

Size Inlet×Outlet	L	H ₁	With lever	Non-lever	Connection		Weight (Non-lever)
			H ₂	H ₂	Inlet	Outlet	
15×15	40	45	160	130	Screwed JIS Rc	Screwed JIS Rc	1.5
20×20	42	50	157	127			1.6
25×25	49	58	169	139			2.1
32×32	57	71	192	162			3.5
40×40	63	78	210	180			4.7

Remarks 1. H₁ : 1mm less for with lever opened.
2. H₁, H₂ : 1mm less for non-lever opened.

**Bronze
16K**

Type R101-1BHA Relief Valve

4

Relief Valve

Features

- Diaphragm seal type valve disc.
- A valve disc made of synthetic rubber prevents seat leakage.
- Pressure setting can be done without taking off the lever.
- Frozen cracking doesn't occur because of its construction and material.



Screwed type



Flanged type

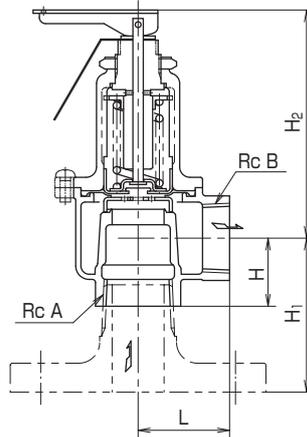

Specifications

Type	Diaphragm seal	
Fluid	Water	
Pressure	Set : 0.05 – 1.6 MPa (back pressure : atmospheric)	
Temperature	0 – 100°C	
Material	Lever	Mild steel
	Adjusting screw	Brass
	Spring seat	Mild steel
	Stem	Stainless steel
	Adjusting spring	Spring wire, piano wire
	Spring case	Bronze
	Diaphragm seat	Stainless steel
	Diaphragm	Synthetic rubber
	Body	Bronze
Flange	Bronze	
Use for	Pressure vessel, outlet of PRV and piping protection	

- Note
1. Back pressure should be atmospheric.
 2. Exhaust piping such a collecting drain should be avoided.
 3. In case of presuming the freezing, insulation should be done sufficiently.

Dimensions and weights

(mm, kg)

Size Inlet × Outlet	L	H (Screwed)	H ₁ (Flanged)	Height		Connection			Weight	
				H ₂	A	Inlet	B	Outlet	Screwed	Flanged (Inlet)
15 × 20	44	33	64	111	1/2	Screwed JIS Rc or Flanged JIS16KFF	3/4	Screwed JIS Rc	1.2	2.0
20 × 25	44	33	67	111	3/4		1		1.2	2.1
25 × 25	44	33	72	111	1		1		1.2	2.7
32 × 32	62	43	82	140	1 1/4		1 1/4		3.0	5.1
40 × 40	62	43	83	140	1 1/2		1 1/2		3.0	5.4

Capacity of Type RPC14, R101-1BHA Relief Valves

Capacity of RPC14 relief valve (Fluid : water)

(kg/h)

Size	15	20	25	32	40	50	65	80
Seat dia. D(mm)	20	20	25	32	40	50	65	80
Lift ℓ (mm)	0.28	0.5	0.63	0.8	1.0	1.25	1.63	2.0
Discharge area A(mm ²)	12.4	22.2	34.9	56.8	88.8	138.8	235.3	355.3
Set pressure(MPa·G)								
0.1	423	758	1191	1939	3032	4740	8036	12134
0.2	598	1072	1685	2743	4289	6704	11364	17160
0.3	733	1313	2064	3360	5252	8210	13919	21017
0.4	847	1516	2383	3879	6065	9480	16072	24269
0.5	946	1695	2665	4337	6781	10600	17969	27133
0.6	1037	1857	2919	4751	7428	11611	19684	29723
0.7	1120	2006	3153	5132	8024	12542	21261	32105
0.8	1197	2144	3371	5486	8578	13408	22729	34321
0.9	1270	2274	3575	5819	9098	14221	24108	36403
1.0	1339	2397	3769	6134	9590	14990	25412	38373
1.1	1404	2514	3953	6433	10058	15722	26653	40246
1.2	1467	2626	4129	6720	10505	16421	27838	42035
1.3	1526	2733	4297	6994	10934	17092	28975	43752
1.4	1584	2836	4459	7258	11347	17737	30068	45403
1.5	1640	2936	4616	7513	11746	18359	31124	46997
1.6	1694	3032	4767	7759	12131	18961	32145	48538
1.7	1746	3126	4914	7998	12504	19545	33134	50032
1.8	1796	3216	5057	8230	12867	20112	34094	51482
1.9	1845	3304	5195	8455	13219	20663	35029	52893
2.0	1893	3390	5330	8675	13563	21200	35939	54267

Remark : Except for G (sp.gr.) = 1, the relieving capacity in the table should be multiplied by \sqrt{G} .

Capacity of R101-1BHA relief valve (Fluid : water)

(kg/h)

Size	15-20	25	32	40
Seat dia. D(mm)	20	25	32	40
Lift ℓ (mm)	0.7	0.8	1.0	1.3
Discharge area A(mm ²)	43.9	62.8	100.5	163.3
Set pressure(MPa·G)				
0.1	1499	2144	3432	5645
0.2	2120	3033	4854	7983
0.3	2596	3714	5945	9778
0.4	2998	4289	6864	11291
0.5	3352	4795	7675	12623
0.6	3672	5253	8407	13828
0.7	3966	5674	9081	14936
0.8	4240	6066	9708	15967
0.9	4497	6434	10297	16936
1.0	4741	6782	10854	17852
1.1	4972	7113	11383	18724
1.2	5193	7429	11890	19556
1.3	5405	7733	12375	20355
1.4	5609	8025	12842	21123
1.5	5806	8306	13293	21865
1.6	5997	8579	13729	22582

Remark : Except for G (sp.gr.) = 1, the relieving capacity in the table should be multiplied by \sqrt{G} .

Cast iron
16K
Screwed

Type RPC14 Relief Valve

4

Relief Valve

Features

- For liquid
- Closed type allow some back pressure
- Useful for back pressure regulating valve

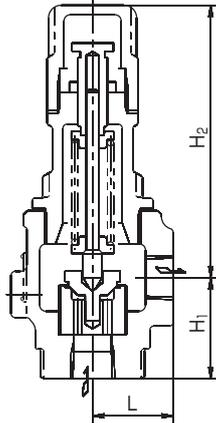

Specifications

Spring case form	Non-lever closed	
Fluid	Water, oil and non-corrosive liquid	
Pressure	Set : 0.04 – 1.6 MPa (back pressure : 1.0MPa or less)	
Temperature	0 – 200°C	
Material	Body	Cast iron
	Valve seat	Stainless steel
	Valve disc	Stainless steel
	Stem	Stainless steel
	Spring case	Cast iron
	Adjusting spring	Spring wire, piano wire
	Cover	Cast iron
	Adjusting ring	Brass
Use for	Pump by-pass, back pressure regulating valve	

Note : In case of being back pressure, inlet pressure will be set pressure + back pressure. Allowable max. inlet pressure is 1.6MPa.

Dimensions and weights

(mm, kg)

Size Inlet × Outlet	L	H ₁	Height H ₂	Connection		Weight
				Inlet	Outlet	
15 × 15	38	48	129	Screwed JIS Rc	Screwed JIS Rc	1.5
20 × 20	38	48	129			2
25 × 25	44	56	140			3
32 × 32	51	70	162			4
40 × 40	57	75	182			5

**Cast iron
10K, 16K
Flanged**

Type RPC14 Relief Valve

Features

- For liquid
- Closed type allow some back pressure
- Useful for back pressure regulating valve

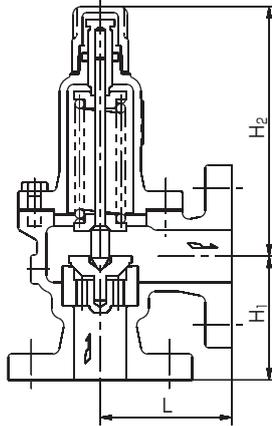

Specifications

Spring case form	Non-lever closed	
Fluid	Water, oil and non-corrosive liquid	
Pressure	Set : 0.04 – 1.6 MPa (back pressure : 1.0MPa or less)	
Temperature	0 – 200°C	
Material	Body	Cast iron (15A – 40A, JIS16K : Spherical graphite cast iron)
	Valve seat	Stainless steel
	Valve disc	Stainless steel
	Stem	Stainless steel
	Spring case	Cast iron
	Adjusting spring	Spring wire, piano wire
	Cover	Cast iron
	Adjusting ring	Brass
Use for	Pump by-pass	

Note : In case of back pressure available, start-to-discharge pressure differs from the set pressure which is adjusted at factory in atmosphere back pressure.

Start-to-discharge pressure (=factory set pressure+back pressure) should not be over nominal pressure of the flange rating.

Dimensions and weights

(mm, kg)

Size Inlet×Outlet	L	H ₁	Height H ₂	Connection		Weight
				Inlet	Outlet	
15× 15	73	68	136	Flanged JIS10KFF	Flanged JIS10KFF	3.8
20× 20	75	70	136			4.2
25× 25	85	85	148			6.5
32× 32	95	90	172			9.2
40× 40	100	95	191			10.8
50× 50	110	105	238			15.6
65× 65	130	120	286			25.7
80× 80	140	135	343			33.2
15× 20	75	83	143	Flanged JIS16KFF	Flanged JIS10KFF	4.7
20× 25	75	85	143			5.4
25× 32	90	90	158			7.5
32× 40	95	95	183			10
40× 50	100	105	206			13
50× 65	115	115	250			17.2
65× 80	130	130	303			26.5
80× 100	145	145	358			38

Cast steel 10K, 20K Flanged

Type RPC14 Relief Valve

Features

- For liquid
- Closed type allow some back pressure
- Useful for back pressure regulating valve

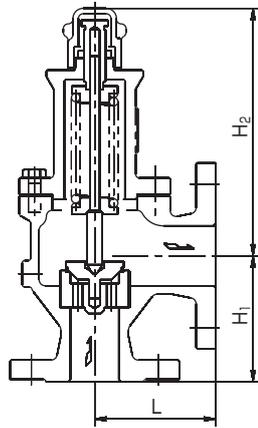

Note : In case of back pressure available, start-to-discharge pressure differs from the set pressure which is adjusted at factory in atmosphere back pressure.

Start-to-discharge pressure (=factory set pressure+back pressure) should not be over nominal pressure of the flange rating.

4 Relief Valve

Specifications

Spring case form	Non-lever closed	
Fluid	Water, oil and non-corrosive liquid	
Pressure	Set : 0.04—1.6 MPa (back pressure : 1.0MPa or less)	
Temperature	-5 — +200°C	-30 — Saturated temp.
Material	Body	Cast iron
	Valve seat	Stainless steel
	Valve disc	Stainless steel
	Stem	Stainless steel
	Spring case	Mild steel, cast steel
	Adjusting spring	Spring wire, piano wire
	Cover	Stainless steel, mild steel
	Adjusting ring	Stainless steel
	Use for	Pump by-pass

Dimensions and weights

(mm, kg)

Size Inlet × Outlet	L	H ₁	Height H ₂	Connection		Weight
				Inlet	Outlet	
15 × 20	85	83	143	Flanged JIS10KRF JIS20KRF	Flanged JIS10KFF	4.1
20 × 25	85	85	143			4.8
25 × 32	90	90	158			7
32 × 40	95	95	183			9.7
40 × 50	100	105	206			11.7
50 × 65	115	115	250			17.3
65 × 80	130	130	311			25
80 × 100	145	145	366			37.9
20 × 25	86.5	83	143	Flanged ANSI·JPI 150RF	Flanged ANSI·JPI 150RF	4.8
25 × 32	91	89.5	158			7
32 × 40	97.5	94	183			9
40 × 50	104.5	105.5	206			11.7
15 × 20	85	84.5	143	Flanged ANSI·JPI 300RF	Flanged ANSI·JPI 150RF	4.1
20 × 25	86.5	86	143			4.8
25 × 32	91	92.5	158			7
32 × 40	97.5	97.5	183			9.7
40 × 50	104.5	109	206			11.7

Cast iron
10K, 16K

Type RPF12 Lift Safety Relief Valves

4

Safety Relief Valves

Features

- Lift type safety relief valve with cast iron body
- Stable operation

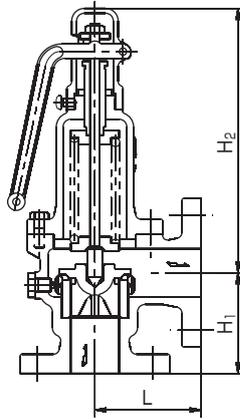

With lever opened

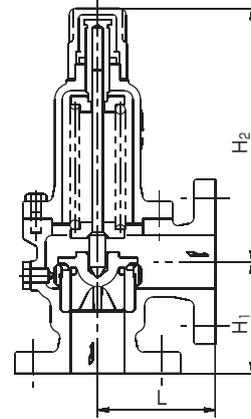

Non-lever closed

Specifications

Spring case form	With lever opened	Non-lever closed		
Fluid	Steam, air	Steam, air, non-corrosive gas and liquid	Water	
Pressure	Set : 0.02 – 1.6 MPa (back pressure : atmospheric)			
Temperature	0 – 220°C	0 – 200°C	Saturated temp.	
Material	Body	Cast iron (15A – 40A JIS16K : Spheroidal graphite cast iron)		
	Valve seat	Stainless steel	Stainless steel stellite	
	Valve disc	Stainless steel	Stainless steel stellite	
	Stem	Stainless steel		
	Spring case	Cast iron		
	Adjusting spring	Spring wire, piano wire		
	Lever	Cast iron		
	Cover	Cast iron		
	Adjusting ring	Bronze, brass		
Use for	Pressure vessel, header, outlet of PRV, thermal relief and piping protection			

Dimensions and weights

(mm, kg)

Size Inlet × Outlet	L	H ₁	With lever	Non-lever	Connection		Weight
			H ₂	H ₂	Inlet	Outlet	
15 × 15	73	68	165	136	Flanged JIS10KFF	Flanged JIS10KFF	4.2
20 × 20	75	70	165	136			4.5
25 × 25	85	85	177	148			6.7
32 × 32	95	90	201	172			9.5
40 × 40	100	95	220	191			11.2
50 × 50	110	105	276	238			16.0
65 × 65	130	120	336	286			26.0
80 × 80	140	135	393	343			33.5
15 × 20	75	83	172	143	Flanged JIS16KFF	Flanged JIS10KFF	4.7
20 × 25	75	85	172	143			5.4
25 × 32	90	90	187	158			7.5
32 × 40	95	95	212	183			10.0
40 × 50	100	105	235	206			13.0
50 × 65	115	115	288	250			17.6
65 × 80	130	130	353	303			27.3
80 × 100	145	145	408	358			38.7

Cast steel,
Stainless steel
10K, 20K

Type RPF12 Lift Safety Relief Valves

Features

- Lift type safety relief valve with cast steel or stainless cast steel body
- Stable operation

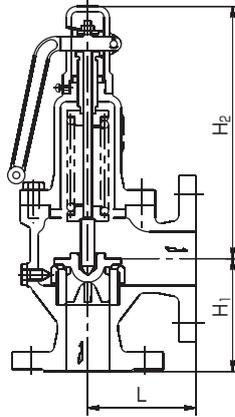

With lever opened

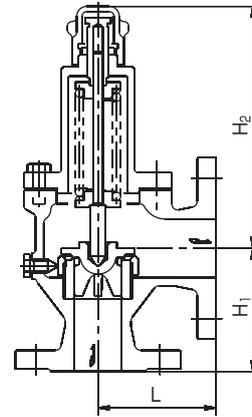

Non-lever closed

Specifications

Spring case form	With lever opened	Non-lever closed		Non-lever closed	
Fluid	Steam, air	Steam, air, non-corrosive gas and liquid		Liquid, gas, steam	
Pressure	Set : 0.02 – 2.0 MPa (back pressure : atmospheric)			0.02 – 2.0MPa	
Temperature	0 – 220°C	– 5 – +200°C		– 30 – +200°C	
Material	Body	Cast steel		Stainless cast steel	
	Valve seat	Stainless steel	Stainless steel stellited	Stainless steel stellited	
	Valve disc	Stainless steel	Stainless steel stellited	Stainless steel stellited	
	Stem	Stainless steel		Stainless steel	
	Spring case	Cast iron	Mild steel, cast steel		Stainless steel
	Adjusting spring	Spring wire, piano wire		Stainless steel	
	Lever	Cast iron	_____	_____	_____
	Cover	Cast iron	Stainless steel, mild steel		Stainless steel
	Adjusting ring	Bronze, brass	Stainless steel		Stainless steel
Use for	Pressure vessel, header, outlet of PRV, thermal relief and piping protection				

Dimensions and weights

(mm, kg)

Size Inlet×Outlet	L	H ₁	With lever	Non-lever	Connection		Weight
			H ₂	H ₂	Inlet	Outlet	
15× 20	85	83	172	143	Flanged JIS10KRF JIS20KRF	Flanged JIS10KFF	4.5
20× 25	85	85	172	143			5.1
25× 32	90	90	187	158			7.2
32× 40	95	95	212	183			10
40× 50	100	105	235	206			12.1
50× 65	115	115	288	250			17.7
65× 80	130	130	353	311			27.3
80× 100	145	145	408	366			38.2
20× 25	86.5	83	172	143	Flanged ANSI 150RF	Flanged ANSI 150RF	5.1
25× 32	91	89.5	187	158			7.2
32× 40	97.5	94	212	183			10
40× 50	104.5	105.5	235	206			12.1
15× 20	85	84.5	172	143	Flanged ANSI 300RF	Flanged ANSI 150RF	4.5
20× 25	86.5	86	172	143			5.1
25× 32	91	92.5	187	158			7.2
32× 40	97.5	97.5	212	183			10
40× 50	104.5	109	235	206			12.1

Cast iron
10K

Type RPN6B Full Bore Safety Valves & Safety Relief Valves

- Full bore type safety relief valve
- For large capacity

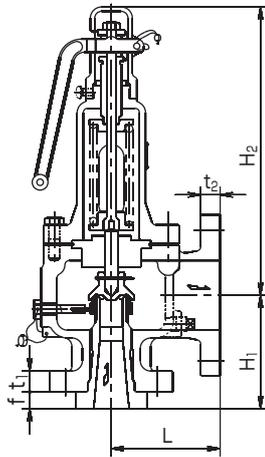

With lever opened
Size25-80

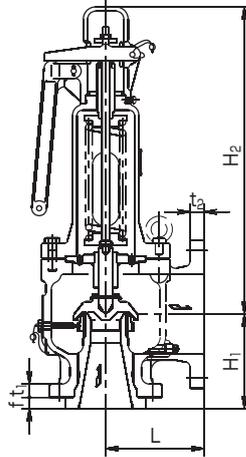

With lever opened
Size100-200

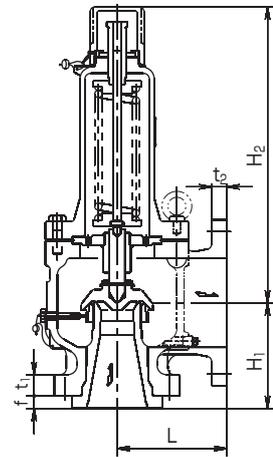

Non-lever closed

4

Safety Valves & Safety Relief Valves

Specifications

Spring case form	With lever opened	Non-lever closed
Fluid	Steam and air	Steam, air, water, non-corrosive gas and liquid
Pressure	Set : 0.05 - 1.0 MPa (back pressure : atmospheric)	
Temperature	0 - 220°C	0 - 200°C
Material	Body	Cast iron
	Valve seat	Stainless cast steel stellited
	Valve disc	Stainless cast steel stellited
	Stem	Stainless steel
	Adjusting spring	Spring wire, piano wire
	Spring case	Cast iron
	Cover	Cast iron
	Lever	Cast iron
Adjusting ring	Bronze and stainless cast steel	

Dimensions and weights

(mm, kg)

Size Inlet × Outlet	Orifice	L	H ₁	Height		Inlet flange			Outlet flange		Weight (Non-lever)
				With lever H ₂	Non-lever H ₂	Thickness t ₁	f	Standard	Thickness t ₂	Standard	
25 × 50	E	114	105	206	178	22	13	JIS 10K	20	JIS10KFF	11
40 × 50	F	121	124	251	223	24	19		20		15
40 × 65	G	121	124	251	223	24	19		22		17
40 × 80	H	124	130	332	295	24	19		22		23
50 × 80	J	124	136	332	295	26	21		22		25
80 × 100	K	165	156	427	378	32	21		24		39
80 × 100	L	165	156	427	378	32	21		24		43
100 × 150	M	184	178	580	500	36	21		26		81
100 × 150	N	210	197	580	500	36	21		26		81
100 × 150	P	229	181	660	580	36	21		26		99
150 × 200	Q	241	240	857	743	42	21	26	187		
150 × 200	R	241	240	857	743	42	21	26	197		
200 × 250	T	279	276	1094	981	46	21	JIS 16K	30	357	

Cast steel,
Stainless steel
10K 20K

Type RPN6B Full Bore Safety Valves & Safety Relief Valves

- Full bore type safety relief valve
- For large capacity

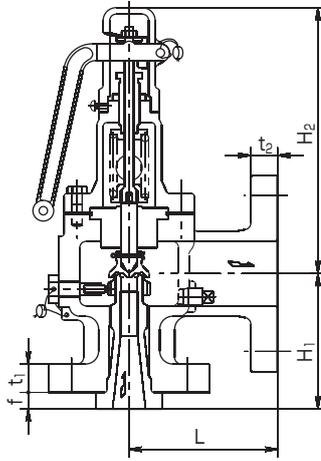

With lever opened
Size 25-80

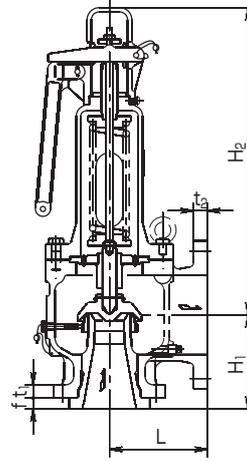

With lever opened
Size 100-200

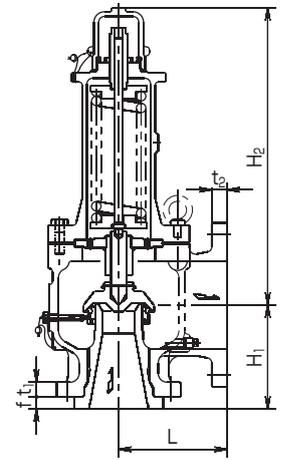

Non-lever closed

4

Safety Valves & Safety Relief Valves

Specifications

Spring case form	With lever opened	Non-lever closed		
Fluid	Steam and air	Steam, air, water, non-corrosive gas and liquid		
Pressure	Set : 0.05-2.0 MPa (back pressure : atmospheric)			
Temperature	0-300°C	-5 - +200°C	-30 - +200°C	
Material	Body	Cast steel	Stainless cast steel	
	Valve seat	Stainless cast steel stellited		
	Valve disc	Stainless cast steel stellited		
	Stem	Stainless steel		
	Adjusting spring	Spring wire, piano wire		Stainless steel
	Spring case	Spherical graphite cast iron	Mild steel, cast steel	Stainless steel
	Cover	Cast iron	Stainless steel, cast steel or mild steel	Stainless steel
	Lever	Cast iron		
	Adjusting ring	Stainless steel		

Dimensions and weights

(mm, kg)

Size Inlet × Outlet	Orifice	L	H ₁	Height		Inlet flange			Outlet flange		Weight (Non-lever)
				With lever H ₂	Non-lever H ₂	Thickness t ₁	f	Standard	Thickness t ₂	Standard	
25 × 50	E	114	105	206	178	22	13	JIS 10K JIS 20K	20.5	JIS10KFF	11
40 × 50	F	121	124	251	223	24	19		20.5		15
40 × 65	G	121	124	251	223	18.5	19		23.5		17
40 × 80	H	124	130	332	295	18.5	19		25		23
50 × 80	J	124	136	332	295	20.5	21		25		25
80 × 100	K	162	156	427	386	25	21		25		39
80 × 100	L	162	156	427	386	25	21		25		43
100 × 150	M	184	178	580	507	25	21		26.5		81
100 × 150	N	210	197	580	507	25	21		26.5		81
100 × 150	P	229	181	660	587	32	21		26.5		99
150 × 200	Q	241	240	857	753	36	21	JIS 10K	30	178	
150 × 200	R	241	240	857	753	36	21		30	178	
150 × 200	Q	241	240	857	753	42	21	JIS 20K	30	187	
150 × 250	R	267	240	1050	935	42	21		30	270	

Type RPN6B Full Bore Safety Valve & Safety Relief Valves

Capacity of RPN6B safety relief valve (Fluid : saturated steam)

(kg/h)

Size	25×50		40×50		40×65		40×80		50×80		80×100			100×150			150×200		150×250	200×250
	Orifice		E	F	G	H	J	K	L	M	N	P	Q	R	R	T				
Throat area A (mm ²)																				
Set pressure (MPa·G)	coefficient C	126.6	198.5	326.8	506.7	834.6	1188	1847	2324	2808	4116.8	7133	10330		16780					
0.1	1.000	113	178	293	454	749	1066	1657	2085	2520	3694	6401	9270		15059					
0.2	1.000	165	259	426	661	1089	1550	2411	3033	3665	5373	9311	13484		21904					
0.3	1.000	222	348	573	888	1463	2083	3239	4076	4925	7221	12511	18119		29433					
0.4	1.003	279	438	722	1119	1843	2624	4080	5134	6204	9095	15759	22823		37074					
0.5	0.999	335	525	865	1342	2210	3146	4892	6156	7438	10904	18894	27362		44448					
0.6	0.995	390	612	1008	1563	2574	3664	5697	7168	8662	12699	22003	31865		51762					
0.7	0.991	445	698	1149	1782	2935	4178	6495	8173	9875	14478	25087	36331		59015					
0.8	0.987	499	783	1289	1999	3293	4687	7287	9169	11079	16243	28144	40759		66209					
0.9	0.985	554	869	1431	2219	3655	5203	8089	10178	12298	18030	31240	45242		73491					
1.0	0.983	609	955	1572	2438	4016	5716	8887	11182	13511	19809	34323	49707		80744					
1.1	0.980	663	1039	1711	2653	4370	6221	9672	12170	14705	21559	37355		54098						
1.2	0.978	717	1124	1851	2870	4728	6730	10463	13165	15907	23322	40409		58521						
1.3	0.976	771	1209	1990	3086	5083	7236	11251	14156	17104	25077	43450		62925						
1.4	0.975	825	1294	2131	3305	5443	7749	12047	15158	18315	26852	46527		67380						
1.5	0.974	880	1380	2272	3523	5803	8260	12842	16159	19524	28624	49596		71826						
1.6	0.973	934	1465	2412	3740	6161	8770	13635	17157	20730	30392	52660		76262						
1.7	0.972	988	1550	2552	3957	6519	9279	14427	18153	21933	32157	55717		80689						
1.8	0.971	1043	1635	2692	4174	6876	9787	15217	19147	23134	33917	58767		85107						
1.9	0.970	1097	1720	2831	4390	7232	10294	16005	20138	24333	35674	61811		89516						
2.0	0.970	1152	1806	2974	4611	7595	10811	16809	21150	25555	37466	64916		94012						

Capacity of RPN6B safety relief valve (Fluid : air 20°C)

(kg/h)

Size	25×50		40×50		40×65		40×80		50×80		80×100			100×150			150×200		150×250	200×250
	Orifice		E	F	G	H	J	K	L	M	N	P	Q	R	R	T				
Throat area A (mm ²)																				
Set pressure (MPa·G)	coefficient C	126.6	198.5	326.8	506.7	834.6	1188	1847	2324	2808	4116.8	7133	10330		16780					
0.1		183	288	474	736	1212	1726	2683	3377	4080	5982	10365	15010		24383					
0.2		267	419	690	1070	1764	2511	3903	4912	5935	8701	15076	21834		35467					
0.3		359	563	928	1439	2370	3374	5245	6600	7975	11692	20259	29339		47659					
0.4		451	708	1165	1807	2976	4237	6587	8289	10015	14683	25441	36845		59850					
0.5		543	852	1403	2175	3583	5100	7929	9977	12055	17674	30624	44350		72042					
0.6		635	996	1640	2543	4189	5963	9271	11666	14096	20666	35807	51856		84234					
0.7		727	1140	1877	2911	4796	6826	10613	13354	16136	23657	40989	59361		96426					
0.8		819	1284	2115	3279	5402	7690	11955	15043	18176	26648	46172	66866		108618					
0.9		911	1429	2352	3648	6008	8553	13297	16731	20216	29639	51355	74372		120810					
1.0		1003	1573	2590	4016	6615	9416	14639	18420	22256	32630	56537	81877		133002					
1.1		1095	1717	2827	4384	7221	10279	15981	20109	24297	35621	61720		89383						
1.2		1187	1861	3065	4752	7828	11142	17323	21797	26337	38612	66903		96888						
1.3		1279	2006	3302	5120	8434	12005	18665	23486	28377	41604	72085		104394						
1.4		1371	2150	3540	5488	9040	12869	20007	25174	30417	44595	77268		111899						
1.5		1463	2294	3777	5856	9647	13732	21349	26863	32457	47586	82450		119405						
1.6		1555	2438	4014	6225	10253	14595	22691	28551	34498	50577	87633		126910						
1.7		1647	2582	4252	6593	10859	15458	24033	30240	36538	53568	92816		134416						
1.8		1739	2727	4489	6961	11466	16321	25375	31928	38578	56559	97998		141921						
1.9		1831	2871	4727	7329	12072	17184	26717	33617	40618	59551	103181		149427						
2.0		1923	3015	4964	7697	12679	18048	28059	35306	42658	62542	108364		156932						

Type RPN6B Full Bore Safety Valves & Safety Relief Valves

Capacity of RPN6B safety relief valve (Fluid : water)

(kg/h)

Orifice Throat area A (mm ²) Set pressure (MPa·G)	Size	25×50	40×50	40×65	40×80	50×80	80×100		100×150			150×200		150×250	200×250
		E	F	G	H	J	K	L	M	N	P	Q	R	R	T
		126.6	198.5	326.8	506.7	834.6	1188	1847	2324	2808	4116.8	7133	10330		16780
0.1		4323	6779	11161	17305	28504	40574	63081	79372	95902	140602	243615	352803		573091
0.2		6114	9587	15784	24473	40311	57380	89210	112249	135626	198841	344523	498939		810474
0.3		7489	11742	19331	29973	49370	70276	109259	137476	166107	243530	421953	611072		992623
0.4		8647	13558	22322	34610	57008	81148	126162	158744	191804	281204	487230	705606		1146183
0.5		9668	15159	24957	38696	63737	90726	141053	177481	214444	314395	544740	788891		1281471
0.6		10591	16606	27339	42389	69821	99385	154516	194421	234911	344403	596732	864187		1403782
0.7		11439	17936	29529	45785	75415	107348	166896	209999	253733	371998	644545	933429		1516258
0.8		12229	19175	31568	48947	80622	114760	178420	224498	271252	397862	689047	997878		1620948
0.9		12971	20338	33483	51916	85512	121722	189243	238116	287707	421806	730845	1058409		1719274
1.0		13673	21438	35295	54724	90138	128306	199479	250996	303269	444622	770378	1115661		1812274
1.1		14340	22484	37017	57395	94538	134568	209216	263247	318072	466324	807980		1170115	
1.2		14978	23484	38663	59947	98741	140552	218519	274953	332215	487060	843907		1222145	
1.3		15589	24443	40242	62395	102773	146291	227442	286180	345780	506948	878367		1272049	
1.4		16178	25366	41761	64751	106653	151814	236027	296983	358833	526085	911524		1320068	
1.5		16746	26256	43227	67023	110396	157142	244311	307407	371428	544549	943517		1366400	
1.6		17295	27117	44645	69221	114017	162296	252324	317488	383609	562408	974460		1411212	
1.7		17827	27952	46019	71352	117526	167291	260089	327259	395415	579717	1004451		1454644	
1.8		18344	28762	47353	73420	120933	172141	267630	336747	406879	596524	1033571		1496817	
1.9		18847	29550	48650	75432	124247	176858	274963	345975	418028	612870	1061893		1537833	
2.0		19336	30318	49914	77392	127475	181452	282107	354963	428888	628791	1089480		1577783	

Remark : Except for G (sp.gr.) = 1, the relieving capacity in the table should be multiplied by \sqrt{G} .