

Direct acting

Type PPD41B-3 Pressure Reducing Valves

For gas

- Negligible influence is exerted by inlet pressure change due to the use of a pressure balancing construction.
- A valve disc made of synthetic rubber ensures tight shut off when closed.
- A strainer (80 mesh) is provided internally for bronze body valve (1.6MPa) and stainless cast steel body valve.
- For the control of highly precise pressure such as in a fuel burner, use PPD41L-3 pressure reducing valve.

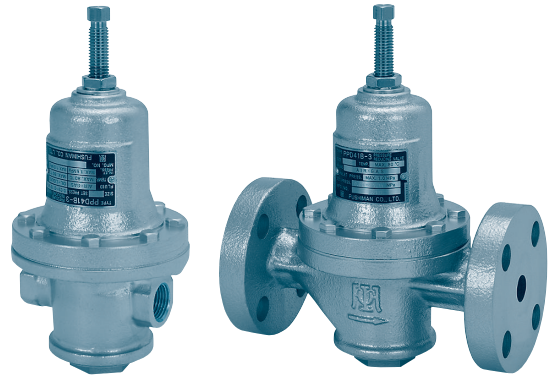

1 Pressure Reducing Valves (For gas)

Specifications

Fluid	Pressure (MPa)		Temp. (°C)	Material for main parts					Connection
	Inlet	Outlet set range		Body	Bottom cover	Spring case	Valve disc	Diaphragm	
Air & non-corrosive gases	0.05 1.6	0.03-0.15 0.1 -0.7	0 80	Bronze	Bronze	Cast iron	Stainless steel & synthetic rubber	Synthetic rubber	JIS Rc Screwed
	0.05 3.0	0.03-0.15 0.1 -0.7 0.6 -1.6		Bronze	Bronze				JIS Rc Screwed
	0.05 1.0	0.03-0.15 0.1 -0.7		Stainless cast steel	Stainless steel				JIS Rc Screwed
	0.05 1.0	0.03-0.15 0.1 -0.7		Cast iron	Bronze				Flanged JIS10KFF
	0.05 2.0	0.03-0.15 0.1 -0.7 0.6 -1.6		Cast steel	Stainless steel				Flanged JIS10KFF or JIS20KRF
	0.05 2.0	0.03-0.15 0.1 -0.7 0.6 -1.6		Stainless cast steel	Stainless steel				

- Remarks
1. ASME flange is available.
 2. Non-copper alloy for fluid contact is available.
 3. 2MPa or less inlet pressure and 0.6-1.6MPa outlet set range with a stainless cast steel body and a JIS Rc screwed is available on request.

Performance

Min. differential pressure	0.02MPa
Offset pressure	10% of max. set range or less
Lockup Pressure	0.02MPa or less
Min. controllable flow (air) (1)	1m³/h (normal)
Seat leakage	0.01% of rated flow or less

Note (1) : Except for air, the flow rate should be divided by \sqrt{G} (G : sp.gr., air : 1).

Flow characteristic curve

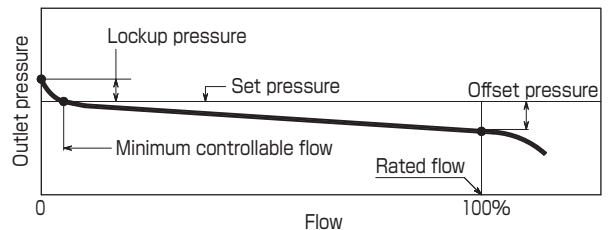

Cv values

Size	15	20	25
Cv	1.8	2.6	3.9

Note

Use as the flow rate either the Cv value calculation or the maximum flow rate, depending on which is the smaller rate. Use the smaller value as the rated flow.

Maximum flow rate conforms to the following formula which is based on the velocity 30m/s at valve outlet.

$$\text{Max. flow rate } V_{LM} = K \cdot P_2 \cdot \frac{273}{G(273+t)} \text{ m}^3/\text{h (normal)}$$

P_2 : Set pressure MPa abs.

t : Temperature °C

G : Specific gravity (air : 1)

K : 218 for size 15

392 for size 20

641 for size 25

Type PPD41B-3 Pressure Reducing Valves

Sizing

Use the following chart to select the suitable valve size.

Example Inlet pressure : 1.0MPa Outlet set pressure : 0.1MPa Temperature : 20°C
 Specific gravity : 0.8 Flow : 70m³/h (normal)

From the intersection of the 0.1MPa outlet set pressure at 20°C temperature line, draw a horizontal line to 1.0 specific gravity line. Continue, in parallel with the oblique line, to the specific gravity 0.8 line.

Draw a horizontal line to the value of 70m³/h (normal) line. This point is between valve size 15 and 20 line.

Select the larger size 20 and continue to check the pressure drop between inlet and outlet of the valve as follows.

This is, from the intersection of the valve size 20 line, draw a vertical line to the pressure drop 1.0-0.1=0.9MPa line. As this point is above the pressure drop boundary line, the valve size 20 is correct.

If inlet pressure is 0.15MPa, the intersection of vertical line and the pressure drop 0.15-0.1=0.05MPa line is below the pressure drop boundary line. In this case, draw a line in parallel with the oblique line, from the above point to the pressure drop boundary line. From the intersection, draw a line downward to the valve size 20 line. This intersection shows 71m³/h (normal) (which is the maximum flow of the valve size 20).

As 71m³/h (normal) is more than the given flow rate 70m³/h (normal), the valve size 20 is adequate.

If given flow rate is 80m³/h (normal), get the maximum flow of valve size 25, by the same procedure shown above, and make sure that the maximum flow is more than 80m³/h (normal). (In this case, the maximum flow of the valve size 25 is 102m³/h (normal). So, the valve size 25 is adequate).

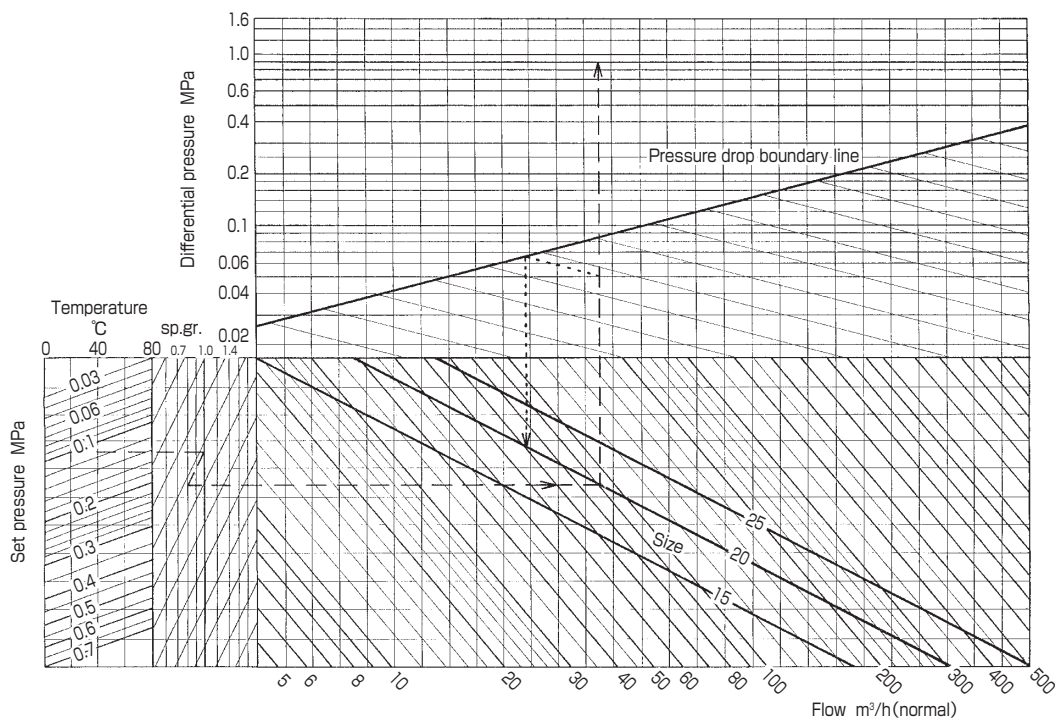

Installation example

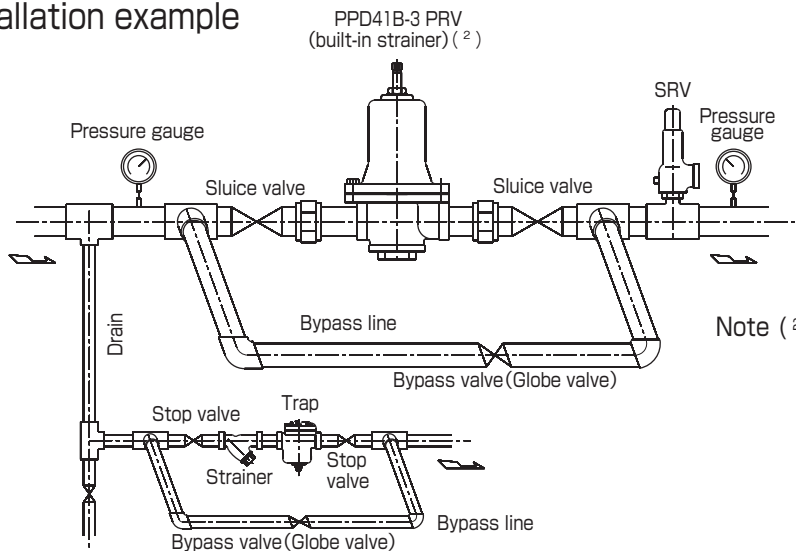

Remark : PPD41B-3 can be installed in both horizontal and vertical piping with upright or upside-down.

Note (²) : This is an example for a bronze body (for 1.6MPa) and a stainless cast steel body. In other cases, install a strainer (with about 80 mesh) at the inlet side.

Type PPD41B-3 Pressure Reducing Valves

Construction

Bronze
1.6MPa
3.0MPa

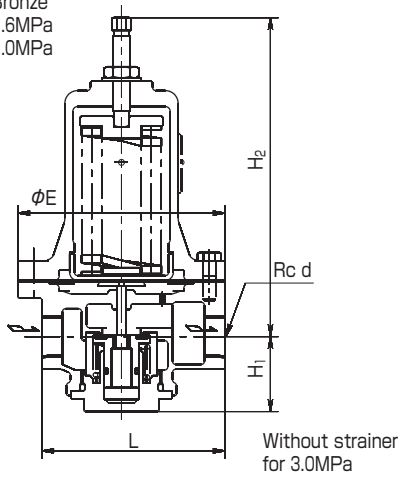

Stainless cast steel
1.0MPa

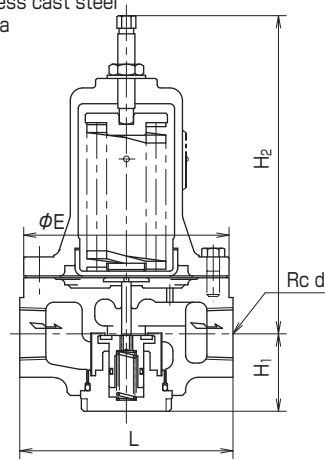

Cast iron

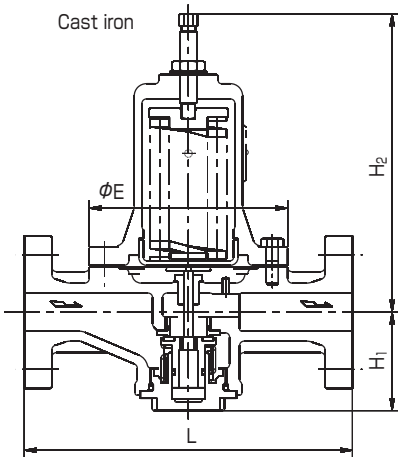

Cast steel

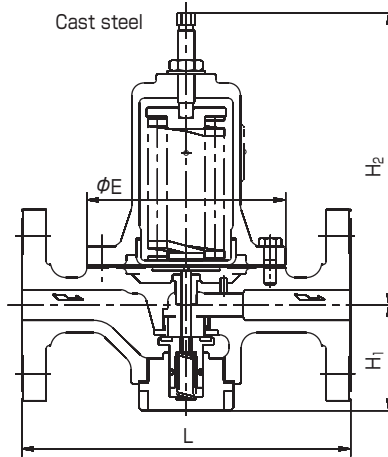

Stainless cast steel

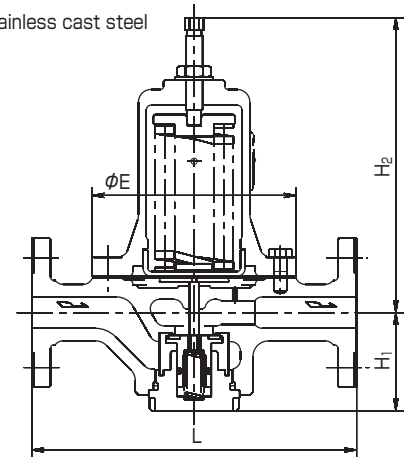

Dimensions and weights

(mm, kg)

Material (body)	Size	Dimensions					Weight	Connection
		d	L	H ₁	H ₂	E		
Bronze	15	1/2	85	43	168	100	2.8 ⁽²⁾	Screwed JIS Rc 1.6MPa 3.0MPa
	20	3/4	115	47	222	130	5.5 ⁽²⁾	
	25	1	115	47	222	130	5.5 ⁽²⁾	
Stainless cast steel	15	1/2	135	49	224	130	6.8	Screwed JIS Rc 1.0MPa
	20	3/4	135	49	224	130	6.8	
	25	1	135	49	224	130	6.7	
Cast iron	15	—	170	54	161	100	4.6	Flanged JIS10KFF
	20	—	215	65	218	130	7.9	
	25	—	215	65	218	130	8.9	
Cast steel ⁽¹⁾	15	—	211	69	213	130	8.3	Flanged JIS20KRF
	20	—	215	69	213	130	8.7	
	25	—	215	69	213	130	9.3	
Stainless cast steel ⁽¹⁾	15	—	207	63	210	130	8.1	Flanged JIS10KFF
	20	—	211	63	210	130	8.5	
	25	—	211	63	210	130	9.3	

Note ⁽¹⁾ : Dimension of L for JIS 10KFF Cast steel and JIS 20KRF Stainless cast steel is different from this table.

⁽²⁾ : Weight for 3MPa, bronze body and screwed: size 15; 3.3kg size 20, 25; 6.5kg.

Direct acting

Type PMD31 Pressure Reducing Valves

For gas

1 Pressure Reducing Valves (For gas)



- Stable operation.
- Negligible influence is exerted by inlet pressure change due to the use of a pressure balancing construction.
- A valve disc made of synthetic rubber ensures tight shut off when closed.
- For smaller flow rate, use PPD41B-3 pressure reducing valve (size 15–25).

Specifications

Fluid	Pressure (MPa)		Temp. (°C)	Size	Material for main parts				Connection
	Inlet	Outlet set range			Body & spring case	Valve disc & diaphragm	Valve seat, liner & bush	Stem	
Air & non-corrosive gases	0.055–1.0	0.035–0.3 0.2–0.7	0–80	15–25 32–80	Cast iron	Synthetic rubber	Bronze	Stainless steel	Flanged JIS10KFF
		0.035–0.3 0.2–0.55		100					
		0.035–0.4		125, 150					

Remarks 1. Cast steel body and stainless cast steel body are available on request.
2. Non-copper alloy material to allow contact with fluid is available.

Performance

Applicable pressure range	Refer to illustration
Min. differential pressure	0.02MPa
Offset pressure	10% of max. set range or less
Lockup pressure	0.01–0.02MPa
Min. controllable flow (air) ⁽¹⁾	5–10m ³ /h (normal)
Seat leakage	0.01% of rated flow or less

Note ⁽¹⁾ : Except for air, the flow rate should be divided by \sqrt{G} (G : sp.gr., air : 1).

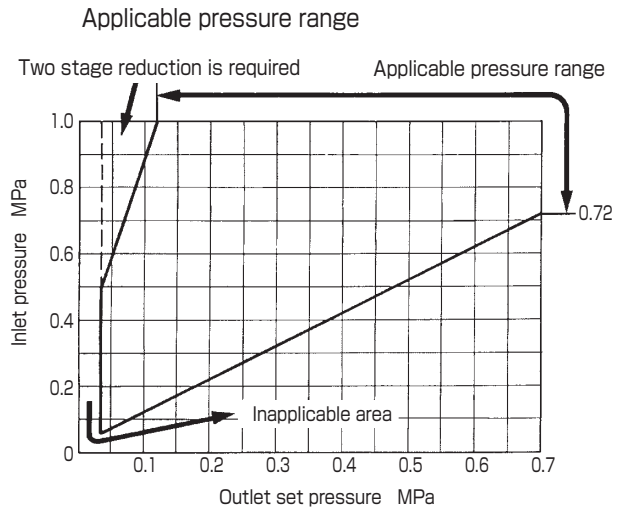

Flow characteristic curve

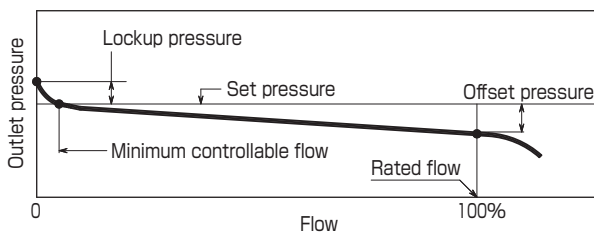

Cv values

Size	15	20	25	32	40	50	65	80	100	125	150
Cv	1.8	2.6	3.9	6.3	8.3	13	21	29	50	76	109

Type PMD31 Pressure Reducing Valves

Sizing

Use the following chart to select the suitable valve size.

In the event that the inlet pressure or the outlet pressure is not constant but stays within range, select the minimum difference in pressure between the inlet pressure and outlet pressure to choose the correct size.

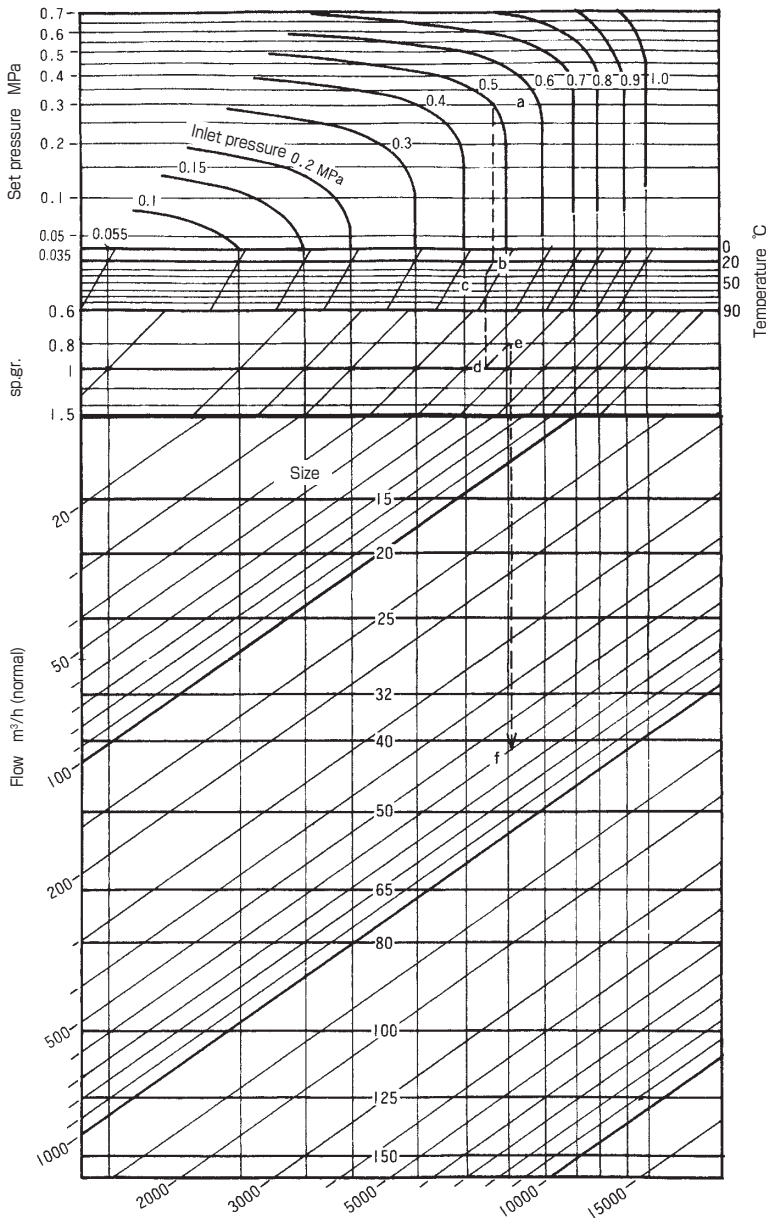

Example

Inlet pressure : 0.5MPa

Outlet set pressure : 0.3MPa

Temperature : 40°C

Specific gravity : 0.8 (air : 1)

Flow : 600m³/h (normal)

From the intersection (a) of 0.5MPa of inlet pressure line and 0.3MPa outlet pressure line, draw a vertical line down to 20°C temperature line, point (b).

From point (b), draw a line in parallel with the oblique line to 40°C temperature line, point (c). Draw a vertical line from point (c) down to 1 specific gravity line, point (d).

From point (d), draw a line in parallel with the oblique line to 0.8 specific gravity line, point (e). From point (e), draw a vertical line downward to 600m³/h (normal) flow line, point (f).

The final point (f) is between the size 40 line and the size 50 line.

The required valve size is 50.

Type PMD31 Pressure Reducing Valves

Construction & Dimensions

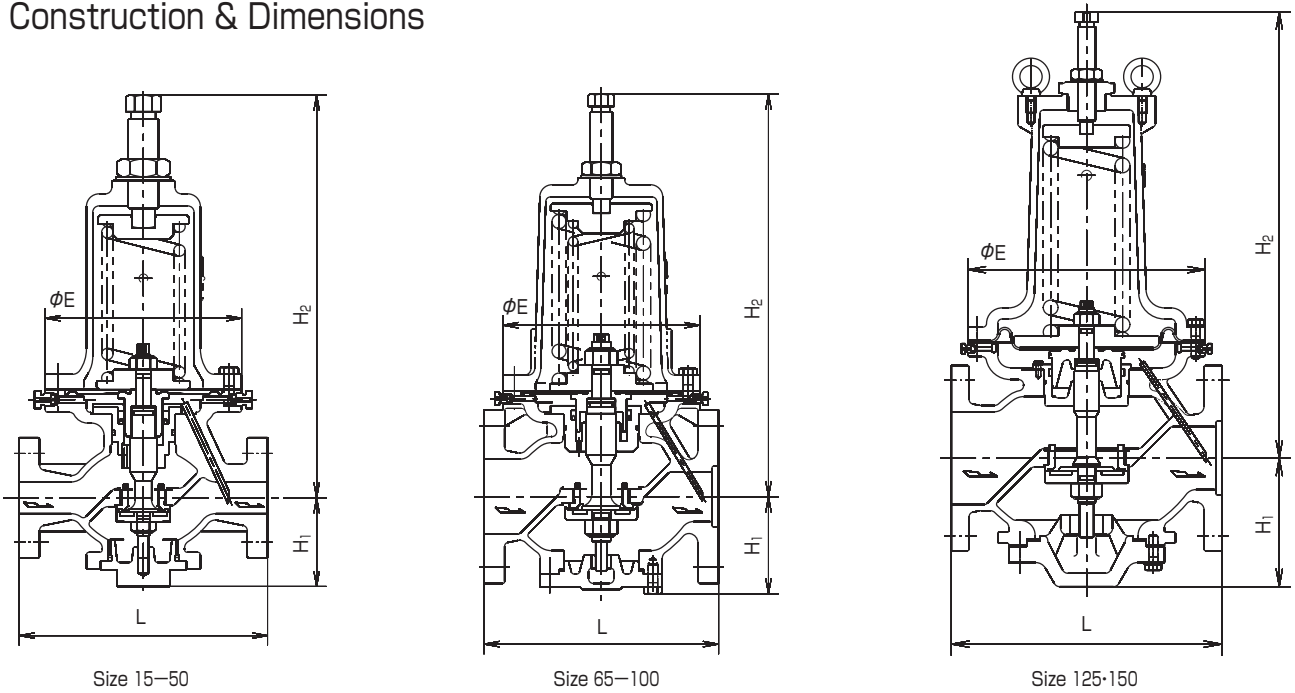

Dimensions and weights

(mm, kg)

Size	Body : Cast iron					Body : Cast steel or Stainless cast steel				
	L	H ₁	H ₂	E	Weight	L	H ₁	H ₂	E	Weight
15	196	70	318	155	12	206	70	318	155	16
20 · 25	200	70	318	155	13	210	70	318	155	17
32	175	70	318	155	14	220	70	318	155	18
40	190	80	328	155	16	220	80	328	155	21
50	195	80	328	155	17	225	80	328	155	22
65	230	104	429	210	34	280	109	429	210	38
80	250	104	429	210	35	280	109	429	210	39
100	290	127	466	250	58	330	121	471	250	65
125	365	174	612	320	98	380	174	612	320	114
150	415	207	792	380	159	470	207	792	380	170

Installation example

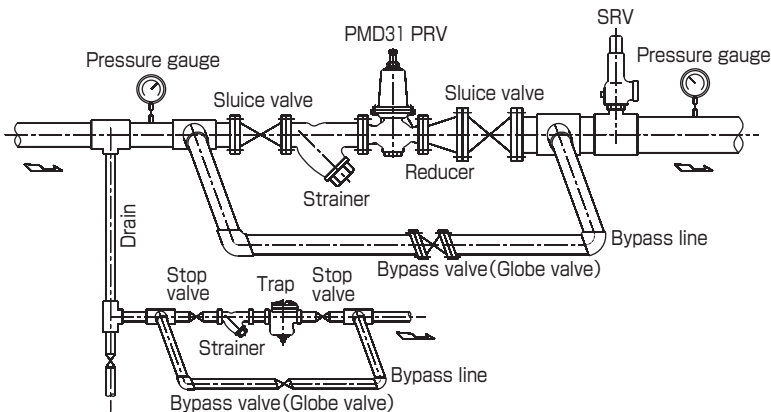

Space required for disassembling and maintenance (mm)

Size	Above the center of pipe line	Beneath the center of pipe line
15-32	470	190
40 · 50	480	200
65 · 80	590	340
100	650	400
125	930	450
150	1220	550

Note : PMD31 can be installed in both horizontal and vertical piping.

Direct acting

Type PMD31L Pressure Reducing Valves

For gas

- Stable operation.
- For low pressure use of PMD31 pressure reducing valve.
- Negligible influence is exerted by inlet pressure change due to the use of a pressure balancing construction.
- A valve disc made of synthetic rubber ensures tight shut off when closed.



1 Pressure Reducing Valves (For gas)

Specifications

Fluid	Pressure (Mpa)		Temp. (°C)	Material for main parts					Connection	
	Inlet	Outlet set range		Body	Diaphragm pusher & liner	Valve disc & diaphragm	Valve seat	Stem		Spring case
Air & non-corrosive gases	0.02	0.01	0 80	Cast iron	Bronze or stainless steel	Synthetic rubber	Bronze or stainless steel	Stainless steel	Cast iron	Flanged JIS10KFF
				Cast steel						
	0.4	0.05		Stainless cast steel	Stainless steel					

Remarks 1. ASME flange is available.
2. Non-copper alloy for fluid contact is available.

Performance

Min. differential pressure	0.01MPa
Offset pressure	Approx. 12% of max. set range (6kPa)
Lockup Pressure	Approx. 3-7kPa ⁽¹⁾
Min. controllable flow (air) ⁽²⁾	Approx. 3-8m ³ /h (normal) ⁽¹⁾
Seat leakage	0.01% of rated flow or less

Note ⁽¹⁾ : The bigger the pressure difference between the inlet and the outlet, the bigger the lockup pressure and the min. controllable flow.
⁽²⁾ : Except for air, the flow rate should be divided by \sqrt{G} (G : sp.gr., air : 1)

Flow characteristic curve

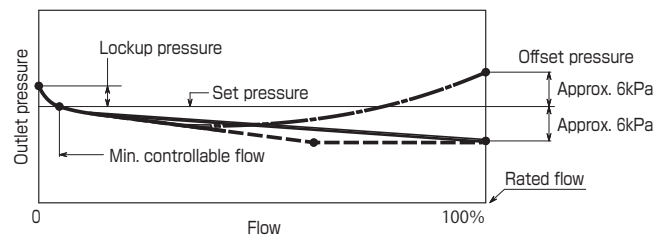

Cv values

Size	15	20	25	32	40	50	65	80	100	125	150
Cv	1.8	2.6	3.9	6.3	8.3	13	21	29	50	76	109

Construction

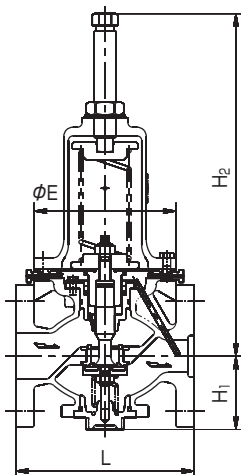

Dimensions and weights

(mm, kg)

Size	Body : Cast iron JIS10KFF					Body : Cast steel or stainless cast steel JIS10KFF				
	L	H ₁	H ₂	E	Weight	L	H ₁	H ₂	E	Weight
15	196	70	364	155	12	206	70	364	155	16
20 · 25	200	70	364	155	13	210	70	364	155	17
32	175	70	364	155	14	220	70	364	155	18
40	190	80	374	155	16	220	80	374	155	21
50	195	80	374	155	17	225	80	374	155	22
65	230	110	488	210	34	280	109	488	210	38
80	250	110	488	210	35	280	109	488	210	39
100	290	127	537	250	58	330	121	542	250	65
125	365	174	690	320	98	380	174	690	320	114
150	415	207	902	380	150	470	207	902	380	162

Type PMD31L Pressure Reducing Valves

Sizing

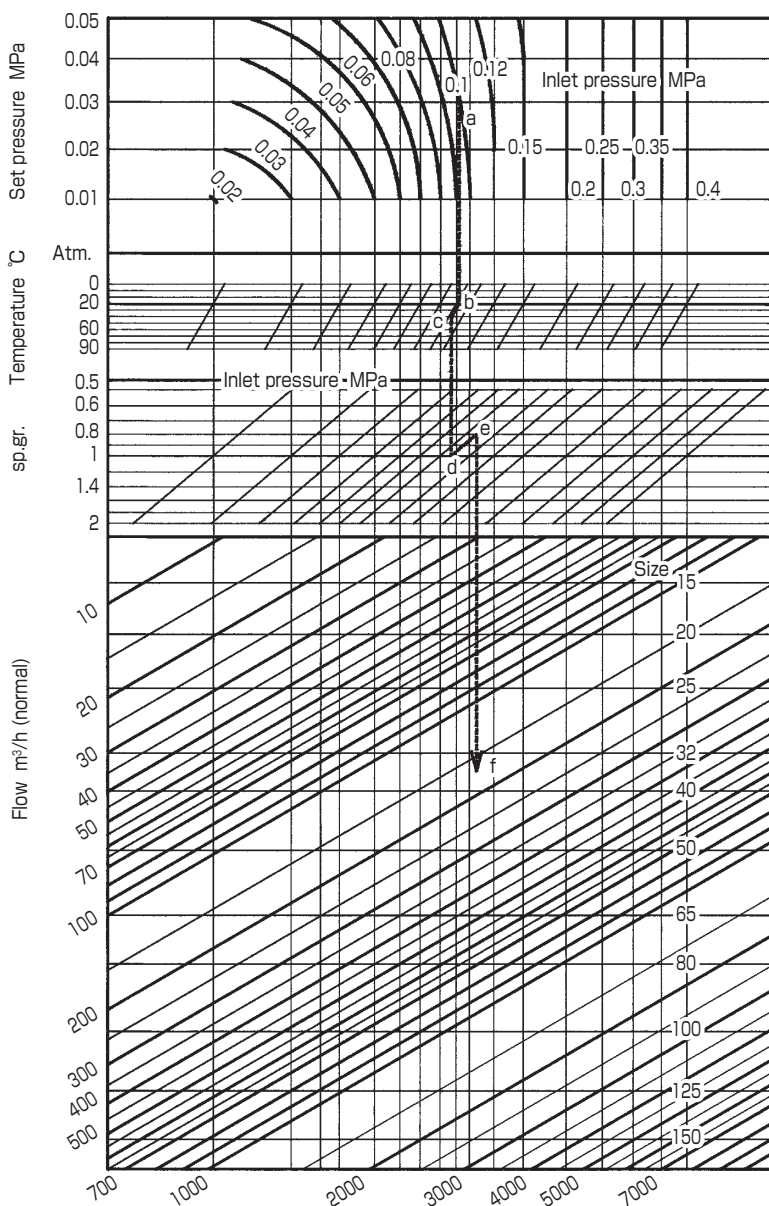

In the event that the inlet pressure or the outlet pressure is not constant but stays within range, select the minimum difference in pressure between the inlet pressure and outlet pressure to choose the correct size.

The valve size selected using this method and the size of the piping are not always the same. The size of piping is determined separately taking allowable pressure loss, cost, etc., into consideration.

Example

Inlet pressure : 0.1MPa
 Outlet set pressure : 0.03MPa
 Temperature : 40°C
 Specific gravity : 0.8 (air : 1)
 Flow : 160m³/h (normal)
 From intersection (a) of 0.1MPa of inlet pressure line and 0.03MPa outlet set pressure line, draw a vertical line down to 20°C temperature line, point (b).
 From point (b), draw a line in parallel with oblique line to 40°C temperature line, point (c).
 Draw a vertical line from point (c) down to specific gravity 1.0 line, point (d).
 From point (d), draw a vertical line in parallel with oblique line to 0.8 specific gravity line, point (e).
 From point (e), draw a vertical line downward to 160m³/h (normal) flow line, point (f).
 Final point (f) is between size 32 line and size 40 line.
 The required valve size is 40.

Installation example

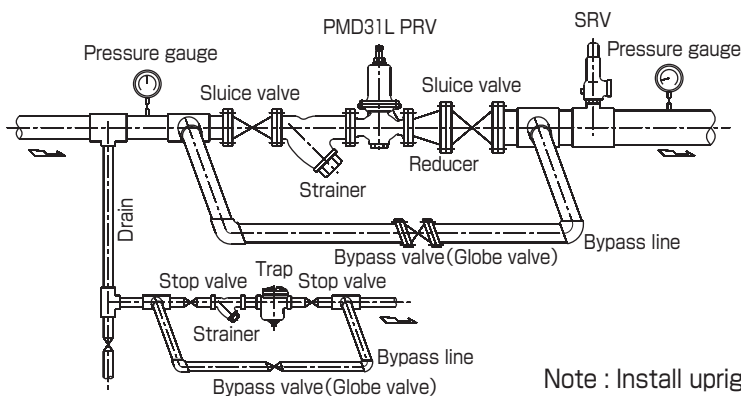

Space required for disassembling and maintenance (mm)

Size	15-32	40-50	65-80	100	125	150
Above the center of pipe line	520	530	650	720	1010	1330
Beneath the center of pipe line	190	200	340	400	450	550

Note : Install upright in horizontal piping.

Direct acting

Type PLG61-2 Pressure Reducing Valves

For gas

- For low pressure use of PMD31L pressure reducing valve.
- Negligible influence is exerted by inlet pressure change due to the use of a pressure balancing construction.
- A valve disc made of synthetic rubber ensures tight shut off when closed.
- PRL pressure reducing valve will be used for size 65 and larger.
- External sensing type.



1 Pressure Reducing Valves (For gas)

Specifications

Fluid	Pressure (kPa)		Temp. (°C)	Material for main parts					Connection
	Inlet	Outlet set range		Body	Diaphragm case	Spring case	Valve seat	Valve disc & diaphragm	
Air & non-corrosive gases	2.5 400	0.5-1.4 1.2-3.3 3.0-8.0 7.0-20	0 80	Cast iron	Rolled steel	cast iron	Bronze	Synthetic rubber	Flanged JIS10KFF

- Remarks
1. Cast steel body and stainless cast steel body are available on request.
 2. Non-copper alloy for fluid contact is available.
 3. ASME flange is available for size 20, 25, 40 and 50.
 4. 0.7MPa or less inlet pressure (in this case, set pressure range is 1.4-3.3, 3.0-8.0, 7.0-18kPa) is available on request.

Performance

Min. differential pressure	2.0kPa
Offset pressure (1)	15% of set pressure (Min. 0.3kPa) or less
Lockup pressure (2)	Size 15, 20, 25 : 0.4kPa or less Size 32, 40, 50 : 1.5kPa or less
Min. controllable flow (air) (2)	Size 15, 20, 25 : 0.5 - 2 m³/h (normal) Size 32, 40, 50 : 5 - 10 m³/h (normal)
Seat leakage	0.01% of rated flow or less

- Note (1) : It will be larger than 15%, depending on pressure condition.
(2) : The bigger the pressure difference between the inlet and the outlet, the bigger the lockup pressure and the min. controllable flow.

Flow characteristic curve

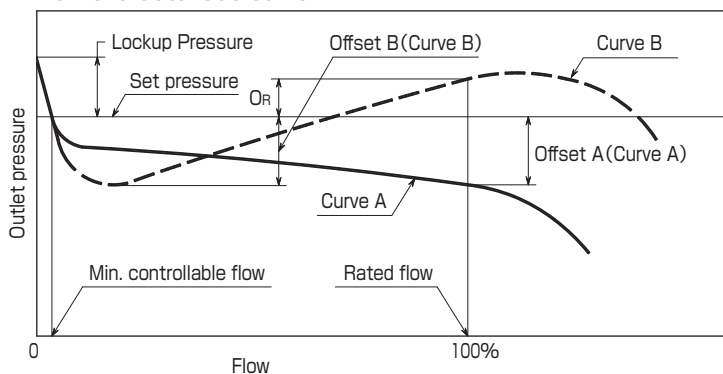

Remark : Flow characteristic will normally follow curve A.
In case of sizes 15-25, when there is a large difference in pressure between the inlet and outlet, it will follow curve B.
In the event that O_R is bigger than offset B, choose O_R .

Cv values

Size	15	20	25	32	40	50
Cv	1.8	2.6	3.9	6.3	8.3	13

Type PLG61-2 Pressure Reducing Valves

Sizing

- When the inlet pressure is in range of 0.2–0.4MPa and the outlet pressure is in the range of 0.5–3.0kPa, use the table of Max. flow rate regardless of specific gravity and temperature. Under the condition where the inlet pressure is beyond 0.4MPa, the flow is at the maximum when it is 0.4MPa.
- In the event that the inlet pressure or the outlet pressure is not constant but stays within range, select the minimum difference in pressure between the inlet pressure and outlet pressure to choose the correct size.
- The valve size selected using the above method and the size of the piping are not always the same. The size of piping is determined separately taking allowable pressure loss, cost, etc., into consideration.

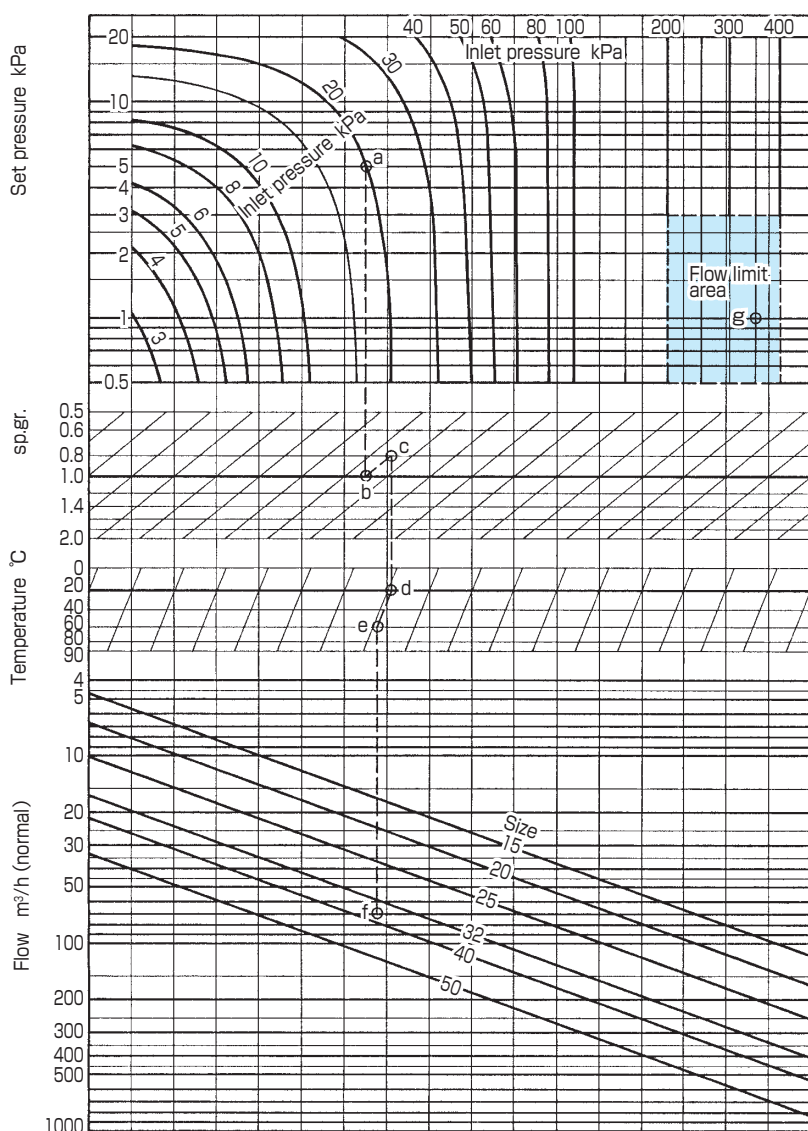

Example A

Inlet pressure : 20kPa
 Outlet pressure : 5kPa
 Temperature : 60°C
 Specific gravity : 0.8 (air : 1)
 Flow : 70m³/h (normal)
 Draw a perpendicular downward from the intersection of 20kPa inlet pressure line and 5kPa outlet pressure until it reaches 1.0 specific gravity line and obtain the intersecting point b.
 From the point b, draw a line upward along the oblique until it reaches 0.8 specific gravity line, the point c.
 Draw a perpendicular downward from the point c until it reaches 20°C temperature line and obtain the point d.
 From there, draw a line downward along the oblique line until it reaches 60°C temperature line, the point e.
 Draw a perpendicular downward from the point e until it reaches 70m³/h (normal) flow line, the point f.
 As the final point f is between size 32 line and size 40 line, the required valve size is 40.

Example B

Inlet pressure : 350kPa
 Outlet pressure : 1.0kPa
 Temperature : 40°C
 Specific gravity : 1.2
 Flow : 150m³/h (normal)
 The intersecting point of 350kPa inlet pressure line and 1.0kPa outlet pressure line the point g, is the flow limited area.
 In this case, use the table of Max. flow rate and select the valve size 32 which allows a flow of more than 150m³/h (normal).

Maximum flow rate (m³/h(normal))

Size	Flow rate (³)
15	60
20	90
25	120
32	200
40	260
50	370

Note (³) : For any kind of fluid.

Type PLG61-2 Pressure Reducing Valves

Construction & Dimensions

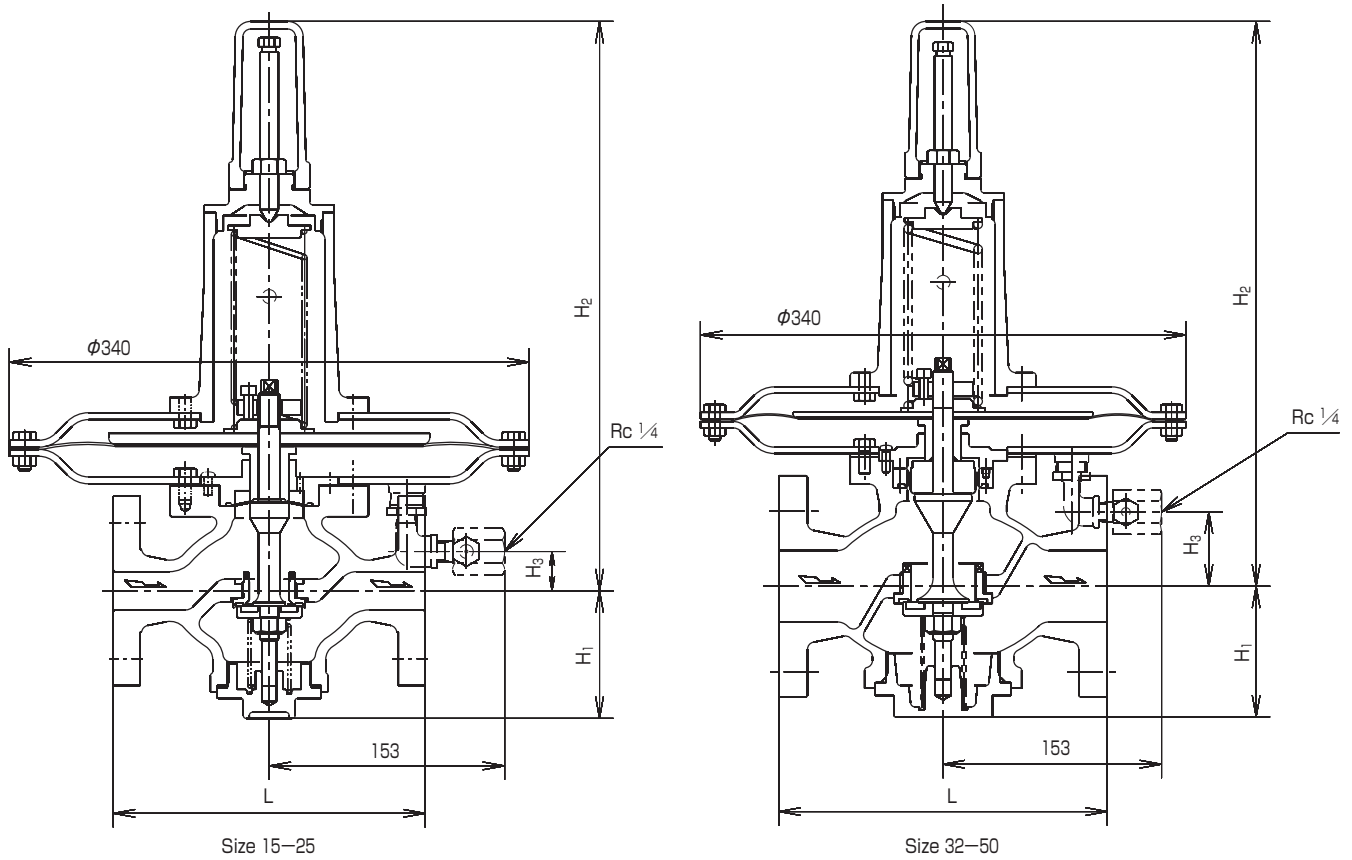

Dimensions and weights (Connection : JIS10KFF)

(mm, kg)

Size	L		H ₁	H ₂	H ₃	Weights	
	Body : Cast iron	Body : Cast steel, Stainless cast steel				Body : Cast iron	Body : Cast steel, Stainless cast steel
15	180	180	81	368	25	18.5	20
20	185	185	81	368	25	18.5	20
25	196	196	84	372	30	20	21
32	220	230	92	395	53	23	25
40	220	230	92	395	53	24	25
50	230	230	92	395	53	25	27

Space required for disassembling and maintenance

(mm)

Size	15 - 50
Above the center of pipe line	600
Beneath the center of pipe line	320

Type PLG61-2 Pressure Reducing Valves

Installation example

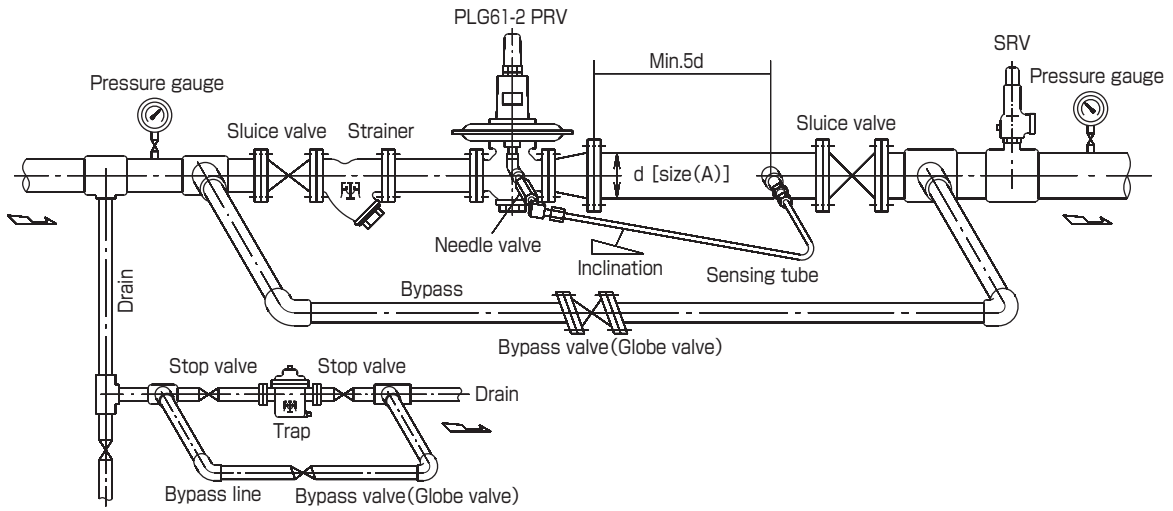

1. Before installation of the pressure reducing valve, the interior of the piping should be thoroughly cleaned. Defective operation is mostly caused by grit, scale and other foreign matter in the pipe, so ensure thorough removal of foreign matter.
2. The pressure reducing valve should be installed upright in horizontal piping and according to the arrow mark on the body.
3. Connect the pressure sensing tube to the inlet piping. The sensing tube should be inclined to avoid drain accumulation. (If drain is not mixed in the fluid, it does not have to be inclined.)
4. Needle valve should be fully opened during normal operation but in the event of unstable operation, it may be closed slightly. However, it should not be fully closed because this would disrupt the pressure reducing valve from operating normally.

Direct acting

Type PRL Pressure Reducing Valves

For gas

- For low pressure and large flow (size 65–150)
- Use PLG61-2 or PMD31L pressure reducing valve for small flow rate (size 15–50).
- External sensing type.

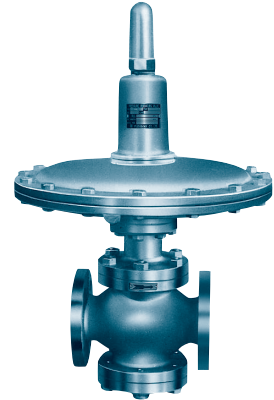

1 Pressure Reducing Valves (For gas)

Specifications

Fluid	Size	Pressure (kPa)		Temp. (°C)	Material for main parts			Connection
		Inlet	Outlet set range		Body	Valve disc & seat	Diaphragm	
Air & non-corrosive gases	65–150	500 or less ⁽¹⁾	1.0–50 ⁽¹⁾	0–80	Cast iron	Stainless steel	Synthetic rubber	Flanged JIS10KFF

Note ⁽¹⁾ : Refer to following table of "Outlet set pressure range and top-work model".

- Remarks
1. Cast steel body and stainless cast steel body are available on request.
 2. ASME flange is available.

Outlet set pressure range and top-work model

Size	Top-work & max. differential pressure (kPa)	Outlet set pressure (kPa)	1.0 or over	over 1.5	over 2.0	over 3.0	over 5.0	over 7.0	over 10	over 15	over 20	over 30
			1.5	2.0	3.0	5.0	7.0	10	15	20	30	50
65	Top-work model		A	B	B	B	C	C	D	D	E	E
	Max. ΔP		150	130	200	340	300	430	420	500	500	500
80	Top-work model		A	A	B	B	B	C	D	D	D	E
	Max. ΔP		140	180	180	290	410	380	370	490	500	500
100	Top-work model		A	A	A	B	B	C	C	C	D	D
	Max. ΔP		110	140	220	240	330	300	460	500	500	500
125	Top-work model		A	A	A	A	A	B	C	C	D	D
	Max. ΔP		84	110	170	280	390	360	350	470	460	480
150	Top-work model		A	A	A	A	A	B	C	C	D	D
	Max. ΔP		68	90	140	230	310	290	280	380	370	390

Remark : Maximum allowable pressure for valve inlet is outlet set pressure + maximum ΔP.

Example : In case of size : 100 and set press. : 10kPa, max. allowable inlet pressure is 300+10=310kPa.

Performance

Range ability	Depend on set pressure and top-work model
Offset pressure	12% of max. set range or less
Min. controllable flow (air)	5% of rated flow
Seat leakage	0.5% of rated flow or less

Cv values

Size	65	80	100	125	150
Cv	35	46	72	123	178

Type PRL Pressure Reducing Valves

Sizing

Select the suitable size by Cv calculation.

In case of $(P_1 - P_2) \leq \frac{P_1}{2}$	In case of $(P_1 - P_2) \geq \frac{P_1}{2}$	Description
$Cv = \frac{V}{3.94} \sqrt{\frac{G(273+t)}{(P_1 - P_2)P_2}} \quad - (1)$	$Cv = \frac{V\sqrt{G(273+t)}}{1.97P_1} \quad - (2)$	V : Flow rate m ³ /h (normal) G : Specific gravity (air : 1) T : Temperature °C P ₁ : Inlet pressure MPa abs P ₂ : Set pressure MPa abs
In case of amb. temp (20°C)		
$Cv = \frac{V}{0.23} \sqrt{\frac{G}{(P_1 - P_2)P_2}} \quad - (3)$	$Cv = \frac{V\sqrt{G}}{0.115P_1} \quad - (4)$	

Example
 Fluid : Air
 Temperature : 40°C
 P₁ : 200kPa
 P₂ : 5.0kPa
 Flow : 1300m³/h (normal)

P₁ = 301.3kPa abs
 P₂ = 106.3kPa abs
 P₁ - P₂ = 195 > $\frac{1}{2} P_1$
 = 150.65
 Cv = 38.8 (Calculate by formula (2))
 Required valve size is 80 (Cv : 46)

Construction

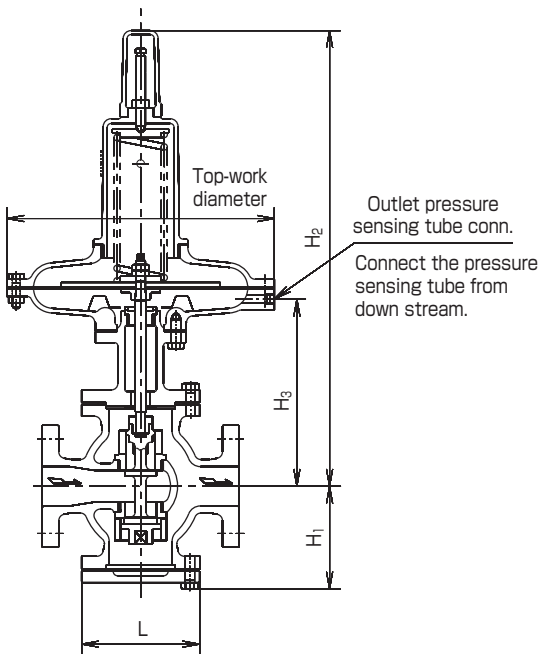

Dimensions and weights

Size	65	80	100	125	150
L	240	270	310	360	380
H ₁	141	146	173	203	222
H ₂	590	602	630	675	694
H ₃	248	260	288	333	352
Weights ⁽²⁾	57	65	81	104	122

Note ⁽²⁾ : In case of top-work C.

Top-work diameter

Model	A	B	C	D	E
Diameter	610	500	410	340	290
Weight fluctuation ⁽³⁾	+27	+12	0	-7	-10

Note ⁽³⁾ : Based on top-work C.

Installation example

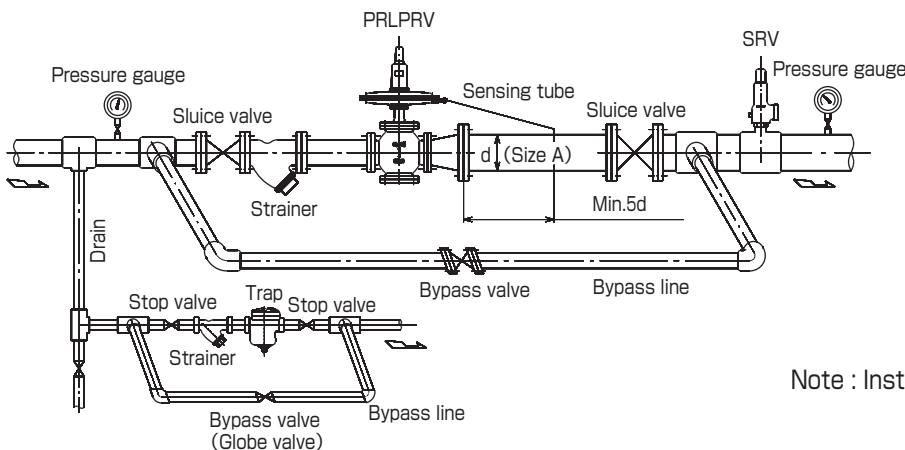

Note : Install upright in horizontal piping.

Direct acting

Type 67R · PPD25 Pressure Reducing Valves

For gas

- For small flow rate and small size.
- Non-bleed type.
- A inner valve with rubber printed ensures tight shut off when closed.

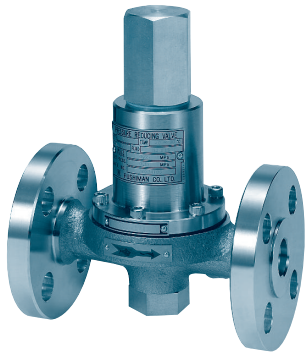
 67R PRV
Screwed

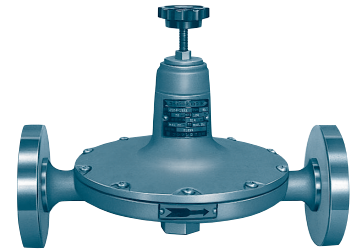
 67R PRV
Flanged

 PPD25 PRV
Screwed

 PPD25 PRV
Flanged

1 Pressure Reducing Valves (For gas)

Specifications

Model	Fluid	Size	Pressure		Temp. (°C)	Material for main parts			Connection
			Inlet (MPa)	Outlet set range		Body	inner Valve	Diaphragm	
67R	Air & non-corrosive gases	8-15	0.055-4.0	0.035-0.16MPa 0.08-0.28MPa 0.2-0.5 MPa (Max. press. reduc. ratio : 25 : 1)	-10 +110	Stainless steel	Stainless steel (rubber printed for 1.6MPa or lower)	Synthetic rubber	Screwed JIS Rc
		10-25				Stainless cast steel			Flanged JIS20KRF
PPD25	Air & non-corrosive gases	8	0.002-0.4	0.5- 2.0kPa 1.0- 5.0kPa 3.0-10 kPa 6.0-20 kPa 15-35 kPa	-10 +80	Bronze	Stainless steel (rubber printed)	Synthetic rubber	Screwed JIS Rc
		8-15				Stainless cast steel			Screwed JIS Rc
		10-25							Flanged JIS10KFF

- Remarks
1. All valves are single seated.
 2. PPD25 should be installed in horizontal piping.
 3. ASME flange is available.

Performance

Type	67R	PPD25
Offset	10% of max.set pressure or less	12% of max.set pressure or less
Seat leakage	0.01% of rated flow or less (0.05% or less for over 1.6MPa of inlet press.)	0.01% of rated flow or less
Cv	0.04 or 0.07	0.07

Type 67R · PPD25 Pressure Reducing Valves

1

Construction

●67R Pressure Reducing Valve

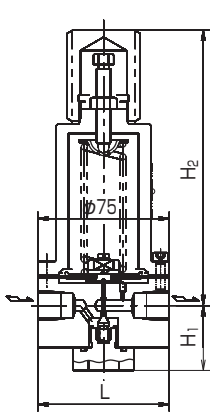

Stainless steel, Screwed
Size 8–15

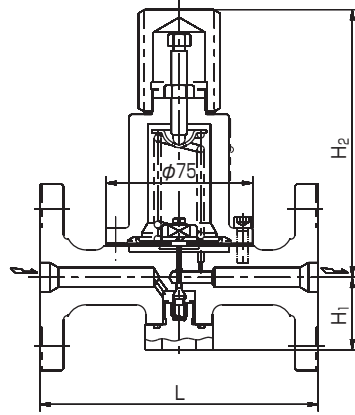

Stainless cast steel, Flanged
Size 10–25

Dimensions of 67R

(mm, kg)

Connection	Size	L	H ₁	H ₂		Weight
				For 0.16 & 0.28MPa	For 0.5MPa	
Screwed JIS Rc	8	75	37	137	158	2.3
	10	75	37	137	158	2.3
	15	75	33	141	162	2.3
Flanged JIS 20K	10	146	37	137	158	4
	15	146	37	137	158	4
	20	150	33	141	162	4
	25	150	33	141	162	5

●PPD25 Pressure Reducing Valve

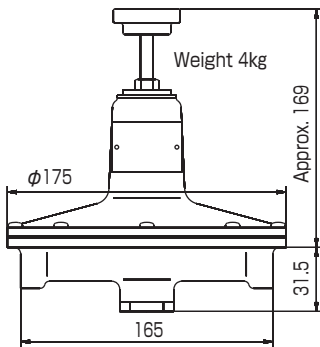

Bronze, Screwed
Size 8

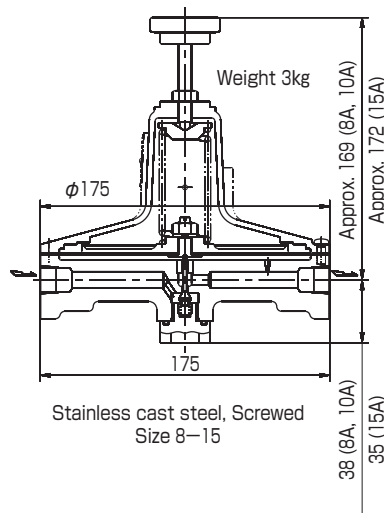

Stainless cast steel, Screwed
Size 8–15

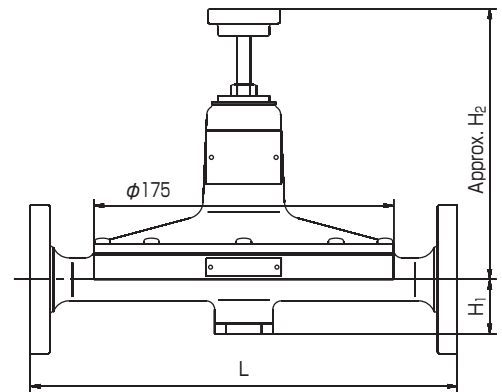

Stainless cast steel, Flanged
Size 10–25A

Dimensions of PPD25 (Flanged JIS10KFF)

(mm, kg)

Size	L	H ₁	H ₂	Weight
10	252	38	169	5.4
15	252	38	169	5.5
20	256	38	169	6
25	256	35	172	6.3

Direct acting

Type 67R · PPD25 Pressure Reducing Valves

For gas

- For small flow rate and small size.
- Non-bleed type.
- A inner valve with rubber printed ensures tight shut off when closed.

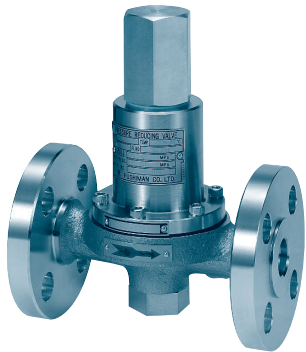
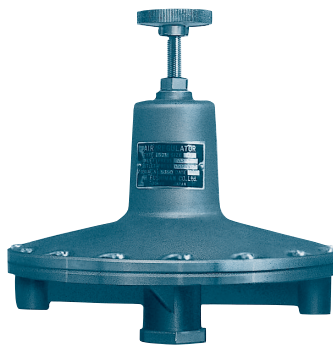
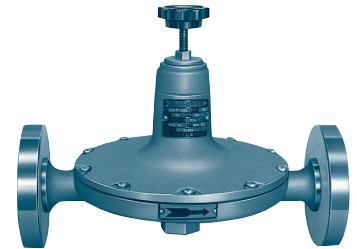
 67R PRV
Screwed

 67R PRV
Flanged

 PPD25 PRV
Screwed

 PPD25 PRV
Flanged

1 Pressure Reducing Valves (For gas)

Specifications

Model	Fluid	Size	Pressure		Temp. (°C)	Material for main parts			Connection
			Inlet (MPa)	Outlet set range		Body	inner Valve	Diaphragm	
67R	Air & non-corrosive gases	8-15	0.055-4.0	0.035-0.16MPa 0.08-0.28MPa 0.2-0.5 MPa (Max. press. reduc. ratio : 25 : 1)	-10 +110	Stainless steel	Stainless steel (rubber printed for 1.6MPa or lower)	Synthetic rubber	Screwed JIS Rc
		10-25				Stainless cast steel			Flanged JIS20KRF
PPD25	Air & non-corrosive gases	8	0.002-0.4	0.5- 2.0kPa 1.0- 5.0kPa 3.0-10 kPa 6.0-20 kPa 15-35 kPa	-10 +80	Bronze	Stainless steel (rubber printed)	Synthetic rubber	Screwed JIS Rc
		8-15				Stainless cast steel			Screwed JIS Rc
		10-25							Flanged JIS10KFF

- Remarks
1. All valves are single seated.
 2. PPD25 should be installed in horizontal piping.
 3. ASME flange is available.

Performance

Type	67R	PPD25
Offset	10% of max.set pressure or less	12% of max.set pressure or less
Seat leakage	0.01% of rated flow or less (0.05% or less for over 1.6MPa of inlet press.)	0.01% of rated flow or less
Cv	0.04 or 0.07	0.07

Type 67R · PPD25 Pressure Reducing Valves

Construction

●67R Pressure Reducing Valve

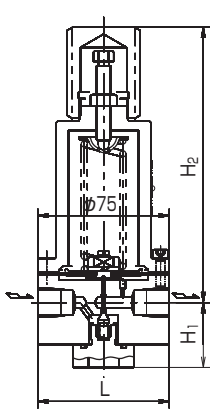

Stainless steel, Screwed
Size 8–15

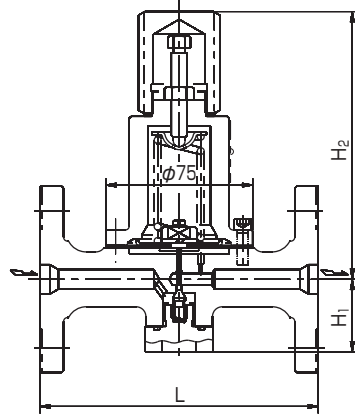

Stainless cast steel, Flanged
Size 10–25

Dimensions of 67R

(mm, kg)

Connection	Size	L	H ₁	H ₂		Weight
				For 0.16 & 0.28MPa	For 0.5MPa	
Screwed JIS Rc	8	75	37	137	158	2.3
	10	75	37	137	158	2.3
	15	75	33	141	162	2.3
Flanged JIS 20K	10	146	37	137	158	4
	15	146	37	137	158	4
	20	150	33	141	162	4
	25	150	33	141	162	5

●PPD25 Pressure Reducing Valve

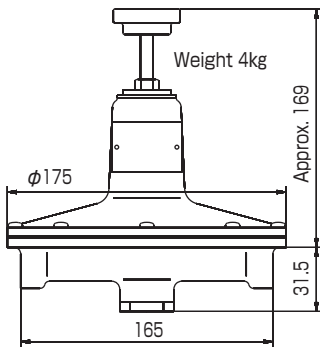

Bronze, Screwed
Size 8

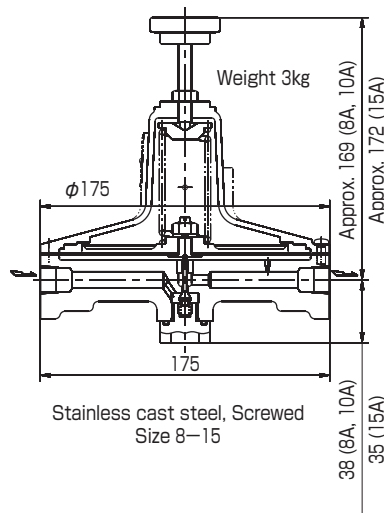

Stainless cast steel, Screwed
Size 8–15

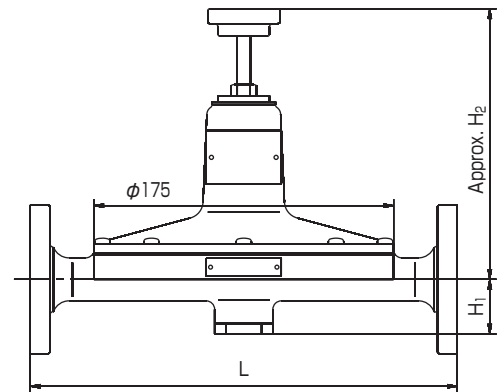

Stainless cast steel, Flanged
Size 10–25A

Dimensions of PPD25 (Flanged JIS10KFF)

(mm, kg)

Size	L	H ₁	H ₂	Weight
10	252	38	169	5.4
15	252	38	169	5.5
20	256	38	169	6
25	256	35	172	6.3

Direct acting

Type PPD41B Pressure Reducing Valves

For gas

1 Pressure Reducing Valves (For gas)

- Negligible influence is exerted by inlet pressure change due to the use of a pressure balancing construction.
- To cope with high pressure use of PPD41B-3.
- For larger flow rate, use type PHP30 pressure reducing valve.

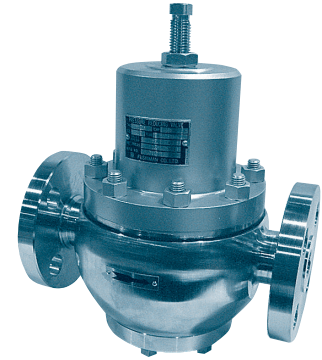

Specifications

Fluid	Pressure (MPa)		Temp. (°C)	Material for main parts					Connection
	Inlet	Outlet set range		Body	Bottom cover	Spring case	Valve disc & stem	Diaphragm	
Air & non-corrosive gases	0.7-4.0	0.6-1.6 1.3-2.3 2.0-3.0	0-80	Stainless steel	Stainless steel	Cast steel or carbon steel	Stainless steel (Teflon seated)	Synthetic rubber	Flanged JIS40KRF

Remarks 1. Cast steel body and stainless cast steel body are available on request.
2. ASME class 300RF and class 600RF flange are available.

Performance

Min. differential pressure	0.1MPa
Offset pressure	Approx. 10% of max. set range
Lockup pressure	Approx. 0.1MPa
Min. controllable flow (air) (¹)	3m³/h (normal)
Seat leakage	0.05% of rated flow or less

Note (¹) : Except for air, the flow rate should be divided by \sqrt{G} (G : sp.gr., air : 1).

Flow characteristic curve

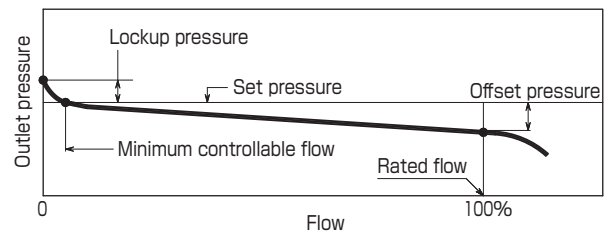

Cv values

Size	15	20	25
Cv	1.8	2.6	3.9

Note

Use as the flow rate either the Cv value calculation or the maximum flow rate, depending on which is the smaller rate. Use the smaller value as the rated flow. Maximum flow rate conforms to the following formula which is based on the velocity 30m/s at valve outlet.

$$\text{Max. flow rate } V_{LM} = K \cdot P_2 \cdot \frac{273}{G(273+t)} \text{ m}^3/\text{h (normal)}$$

P_2 : Set pressure MPa abs.

t : Temperature °C

G : Specific gravity (air : 1)

K : 218 for size 15

392 for size 20

641 for size 25

Construction & Dimensions

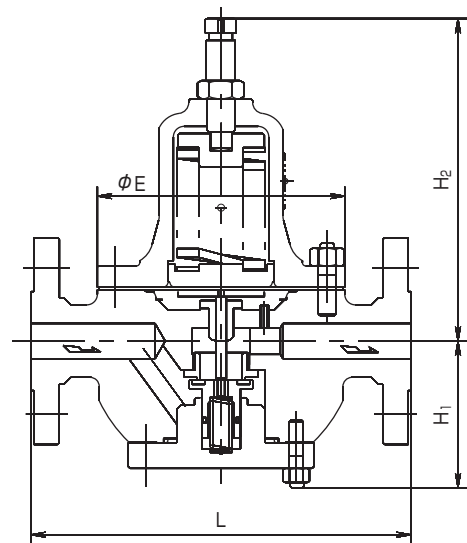

Dimensions and weights

Size	L	H ₁	H ₂	E	Weight
15 · 20	223	83	182	140	18
25	227	83	182	140	20

Direct acting

Type PPD41L-3 Pressure Reducing Valves

For gas

- For low pressure use of PPD41B-3 pressure reducing valve.
- A valve disc made of synthetic rubber ensures tight shut off when closed.
- A strainer is built in stainless cast steel body valve.
- Use PMD31L pressure reducing valve for larger flow rate.
- Suited best for the control of highly precise pressure such as in a fuel burner.

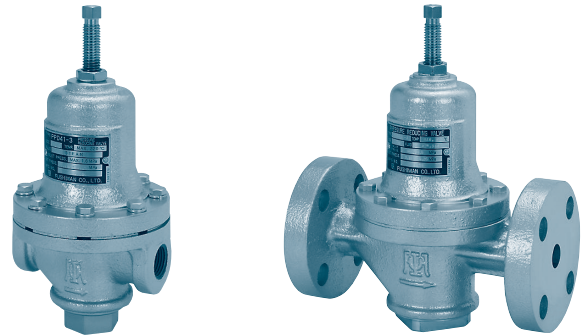

1 Pressure Reducing Valves (For gas)

Specifications

Fluid	Pressure (MPa)		Max. Temp. (°C)	Material for main parts					Connection
	Inlet	Outlet set range		Body	Bottom cover	Spring case	Valve disc	Diaphragm	
Air & non-corrosive gases	0.03 0.5	0.01–0.05 0.03–0.15	0 80	Cast iron	Bronze	Cast iron	Stainless steel & synthetic rubber	Synthetic rubber	JIS Rc Screwed
				Cast iron	Bronze				Flanged JIS10KFF
				Cast steel	Stainless steel				
				Stainless cast steel					

Performance

Min. differential pressure	0.02MPa
Offset pressure	Approx. 10% of max. set range (min. 0.01MPa)
Lockup Pressure	Approx. 5% of max. set range
Min. controllable flow (air)	Approx. 0.3m ³ /h (normal)
Seat leakage	0.01% of rated flow or less
Cv	1.8
Max. flow	Size 15 : 20m ³ /h (normal) Size 20, 25 : 35m ³ /h (normal)

Flow characteristic curve

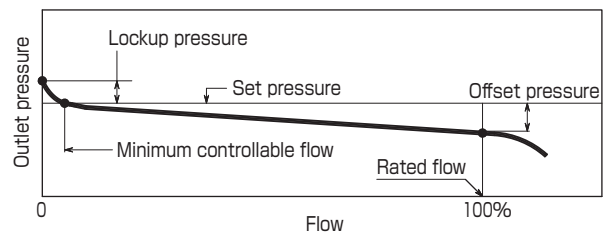

Construction

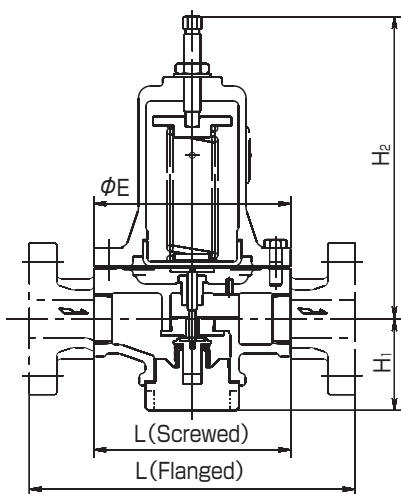

Dimensions and weights

(mm, kg)

Body	Size	Dimensions				Weights	Connection
		L	H ₁	H ₂	E		
Cast iron	15	95	49	165	100	2.6	JIS Rc Screwed
	20	130	61	222	130	5.8	
	25	130	61	222	130	5.8	
Cast iron	15	170	54	161	100	4.6	Flanged JIS10KFF
	20	215	65	218	130	7.9	
	25	215	65	218	130	8.9	
Cast steel	15	207	69	213	130	8.3	Flanged JIS10KFF
	20	211	69	213	130	8.7	
	25	211	69	213	130	9.3	
Stainless cast steel	15	207	63	210	130	8.3	Flanged JIS10KFF
	20	211	63	210	130	8.7	
	25	211	63	210	130	9.3	

Installation example

Same as that of PLG41 pressure reducing valve. Please refer to it.

Direct acting

Type PLG41 Pressure Reducing Valves

For gas

- For low pressure use of PPD41L-3 pressure reducing valve.
- A valve disc made of synthetic rubber ensures tight shut off when closed.
- Use PLG61-2 pressure reducing valve for large flow rate.



1 Pressure Reducing Valves (For gas)

Specifications

Fluid	S ize	Pressure (kPa)			Max. Temp. (°C)	Material for main parts					Connection
		Inlet	Outlet set range			Body	Bottom cover	Spring case	Valve disc	Diaphragm	
Air & non-corrosive gases	20 · 25	2.3 400	#1	0.3-1.0	0 80	Stainless cast steel	Stainless steel	Aluminium alloy casting	Stainless steel & synthetic rubber	Synthetic rubber	Screwed JIS Rc
			#2	0.8-5.0							
			#3	2.0-10							
			#4	6.0-20							
			#5	15-35							
										Flanged JIS10KFF	

Performance

Min. differential pressure	2kPa	
Offset pressure	Approx. 15% of max. set pressure (min. 0.4kPa) or less	
Lockup Pressure	Approx. 0.4kPa	
Min. controllable flow (air)	Approx. 0.3m³/h (normal)	
Seat leakage	0.01% of rated flow or less	
Cv	1 (#1, 2) 1.3 (#3-5)	
Max. flow	Set press. lower than 5kPa	20m³/h (normal)
	Set press. 5kPa and above	30m³/h (normal)

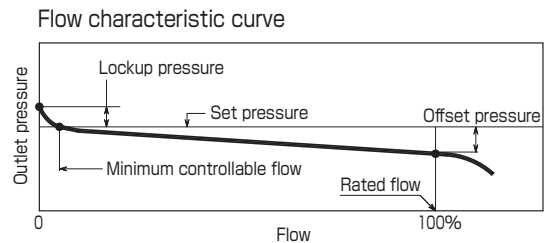

Construction

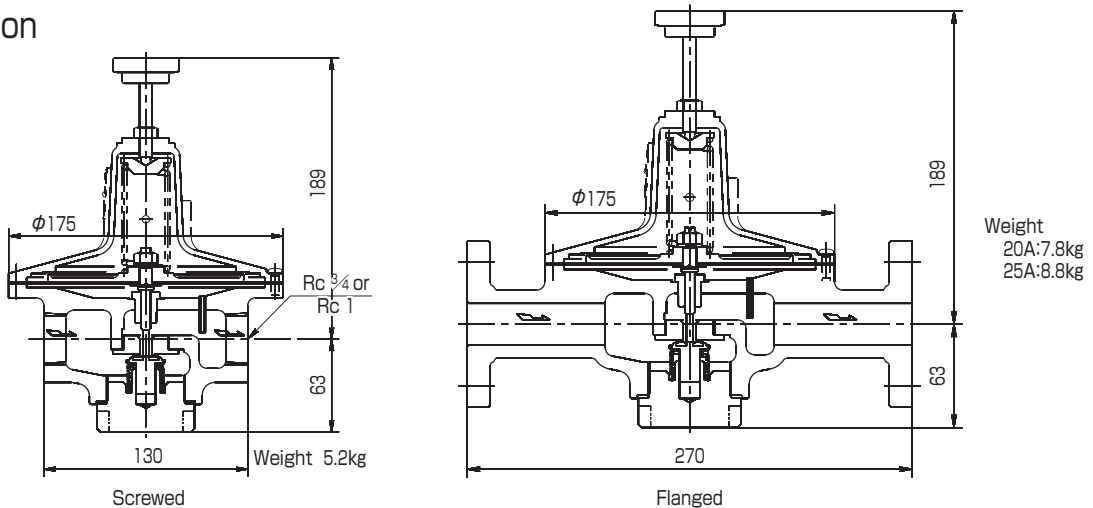

Installation example

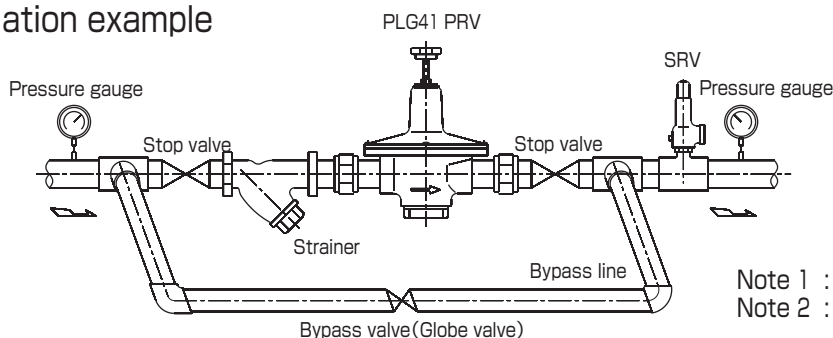

Note 1 : Install upright in horizontal piping.
 Note 2 : The outlet straight pipe line needs 1m or more apart from the valve.