

NELES

Jamesbury™ 2" (DN 50) 6RA3 top-loading and unloading full-port angle ball valves for tank car applications (AAR no. E172115)

A full-port ball valve, the 6RA3 is designed for top loading and unloading of tank cars. These ball valves offer the advantages of quick quarter-turn operation, long service life, and easy cycling. They are much faster to operate than multi-turn types of valves. In addition, they are easy to cycle even after being set in one position for extended periods.

UNIQUE SEALING

The superior performance of Jamesbury™ tank car ball valves is achieved by the unique design of the seat. The flexible-lip PTFE seats exert continuous sealing pressure on the ball. The seat automatically compensates for wear and for changes in temperature and pressure.

In addition, these valves are designed to withstand the demanding service requirements of the railroad industry.

In Jamesbury's "corner sealing" of the stem, the compression of low-friction box rings tops stem leakage by avoiding straight-line leakage paths. Stem seal adjustment, if required, is done simply by tightening the packing unit.

MATERIALS

6RA3 valves are available in carbon steel with 316 stainless steel trim and all 316 stainless steel. Other materials are available for special applications.

FIRE-TITE™ DESIGN

All Jamesbury tank car ball valves have the Jamesbury Fire-Tite design. In the event of a fire resulting in partial or complete destruction of the PTFE seats, a secondary metal sealing surface provides continuous effective shutoff.

FLOW DATA

The 2" (DN 50) 6RA3 has an installed Cv value of 150. Cv is defined as the flow of water at 60°F through the valve in

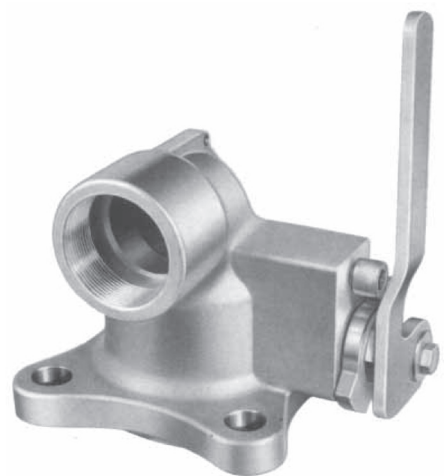

U.S. gallons per minute at a pressure drop of 1 psi (.07 bar). This Cv value is an estimate of the installed flow capacity and considers typical inlet losses. The metric equivalent, Kv, is the flow of water at 16°C through the valve in M3/hr at a pressure drop of 1 kg/cm. To convert Cv to Kv, multiply by 0.8569.

RATINGS

6RA3 valves are rated for pressures and temperatures well in excess of those that are normally encountered in tank car service. Carbon steel valves are rated from -20°F to +500°F (-29°C to +260°C). 316 stainless-steel valves are rated from -60°F to +500°F (-51°C to +260°C). The pressure rating is 600 psi (41 bar) at ambient temperature.

SERVICE

Representative stocks of 6RA3 valves are maintained by Neles' network of authorized stocking distributors located in key areas of the United States and Canada. They will be happy to assist you in the selection of the most cost-effective valve for your application. Visit our website at www.neles.com.

DIMENSIONS

2" (DN 50) 6RA3 Top-Loading and Unloading Full-Port Angle Ball Valves – inches (mm)

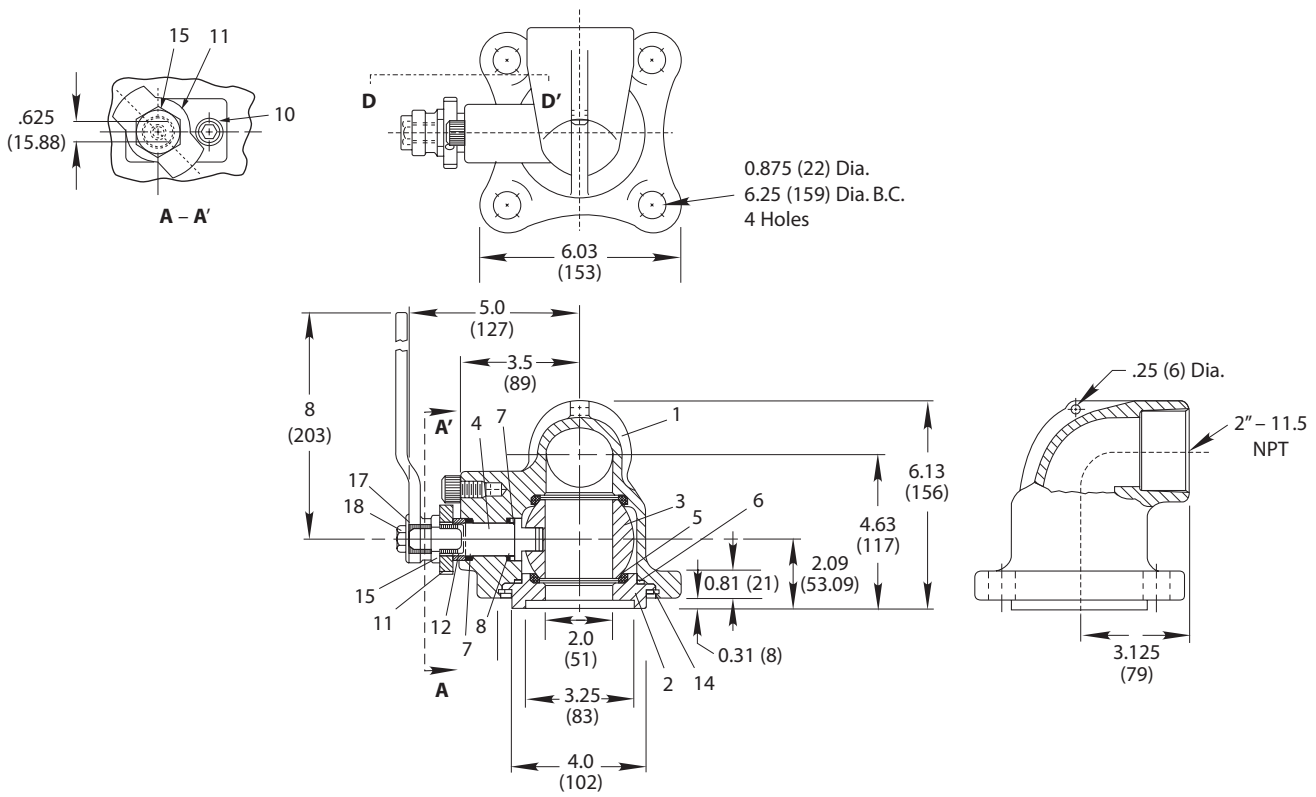

Figure 1

BILL OF MATERIAL AND PARTS LIST			
Part Number	Part Name	Carbon Steel with 316 Stainless Steel Trim (2236)	316 Stainless Steel (3600)
1	Body	Carbon Steel ASTM A216 Type WCB	316 Stainless steel ASTM A351 Type CF8M
2	Body Insert	Carbon steel	316 Stainless steel
3	Ball		316 Stainless steel
4	Stem		316 Stainless steel
5	Seat		PTFE
6	Body Seal		Spiral wound 316 Stainless steel and PTFE
7	Stem Seal		PTFE or Filled PTFE
8	Secondary Stem Seal		Graphite
10	Stop Screw		Stainless steel
11	Indicator Stop	Carbon steel	Stainless steel
12	Compression Ring		Stainless steel
13	Handle		Carbon steel
14	Spirolox Ring	Carbon steel	Stainless steel
15	Stem Nut		Carbon steel
17	Washer		Carbon steel
18	Hex Head Cap Screw		Carbon steel
19	Identification Tag		Stainless steel
20	Drive Screw		Stainless steel
* Optional trim materials offered upon request.			

HOW TO ORDER 6RA3 BALL VALVES

To specify one of these valves, it is necessary only to select the proper body and seat material to meet a particular service requirement. All other components are of materials appropriate for the most severe conditions.

The catalog designations below fully describe a valve, identifying body, trim, seat, and seal materials. The codes are:

Carbon steel body with 316 Stainless steel trim:

2" (DN 50) 6RA3-2236 TT

316 Stainless steel body and trim:

2" (DN 50) 6RA3-3600 TT

For filled PTFE seats, simply substitute MT or TT.

To order a Service Kit for these valves, specify RKN79 TT or MT.

Subject to change without prior notice. Neles, Jamesbury and Easyflow by Neles, and certain other trademarks, are either registered trademarks or trademarks of Neles Corporation or its subsidiaries or affiliates in the United States and/or in other countries. For more information www.neles.com/trademarks

Neles

Vanha Porvoontie 229, 01380 Vantaa, Finland.
Tel. +358 10 417 5000.

neles.com

Reinventing
reliability