

UTE

EXCCO[®]-F

FORGED STEEL

GATE

GLOBE

CHECK

VALVES

Quick look at Utsue Valve

Utsue Valve (UTE) has, over the years, manufactured and sold more than 3 million small-sized forged-steel valves. We have customers all around the world, in the power generation, oil refinery and petrochemical industries, and more. Already, our EXCO-F Series (newly developed production started in 1978) is well-distributed and highly acclaimed amongst users for its reliability and cost-performance. This is one example of how we have continued to brush up our technical know-how. Both in name and virtue, we can honestly recommend products of the EXCO-F Series over similar products sold both in and outside of Japan. With our larger sizes of cast steel valves, we hope to have your further trust and patronage.

History

- Aug. 1931 Founded.
- Oct. 1939 Placed under the Navy supervision.
- Dec. 1943 Reorganized as Nihon Valve Industry Co., Ltd.
- Jan. 1944 Placed under Naval Ministry and Munitions Ministry.
- Nov. 1951 Certified as an authorized manufacturer under JIS (Japan Industrial Standard).
- May 1954 Renamed as Utsue Valve Co., Ltd.
- Feb. 1961 Designated model factory under enterprise restructuring program.
- Feb. 1964 Concluded a technical assistance agreement with Manning, Maxwell & Moore Inc., USA (now Dresser Industries Corp.).
- Jan. 1969 Certified as an authorized manufacturer by API (American Petroleum Institute); products receive the API mark.
- Aug. 1972 Approved as a facility for testing of high pressure gas equipment.
- Nov. 1972 High temperature, high pressure large die-forged valve (CDF valve) developed in cooperation with THE JAPAN STEEL WORKS, LTD.
- Aug. 1976 Certified as an authorized manufacturer by ASME (American Society of Mechanical Engineers); products receive ASME's 'N' stamp.
- Jan. 1978 Successfully concluded the technical assistance agreement with Dresser Industries Corp. Started production and sales of EXCO-F Series compact forged steel valves.
- Oct. 1982 Awarded Class 1 Certificate for industrial safety by Labor Standards Bureau, Ministry of Labor (1.5 million combined work hours without an accident).
- Dec. 1982 Welding method at factory authorized by MITI (Ministry of International Trade and Industry).
- Apr. 1988 Certified as a General Construction Business (Tube Work) Enterprize By Osaka Prefecture.
- Jun. 1992 Awarded Class 4 Certificate for industrial safety by Labor Standards Bureau, Ministry of Labor (5.1 million combined work hours without an accident).
- Jul. 1995 Conferred Safety Promotion Award by Ministry of Labor.

Areas of business

Manufacture, sales (domestic & import/export) and service of high-temperature, high-pressure valves

Contents

Quick look at Utsue Valve	1
History	
Areas of business	
Safety Precautions	
Everything from Taking Orders to Aftercare Service	2
EXCO-F Forged Steel Valves	3
EXCO-F (Class 800)	
Gate Valve Type E115/E215	5
EXCO-F (Class 600)	
Globe Valve Type E135/E235	7
EXCO-F (Class 1500/2500)	
Globe Valve Type E137/E139	9
EXCO-F Ultra High Pressure (Class 4500)	
Globe Valve Type E13C	11
EXCO-F (Class 600)	
Check Valve Type E155/E255/E465 ...	12
EXCO-F (Class 600)	
Flow Rate Control Valve Type E735/UH35	13
End-to-End Distance on Flanged valves	14
Engineering Sheet	15
Flange dimensions	
Hydrostatic pressure test	
Formulas for calculating Cv	
Motor operated valve specifications	
Needle valve specifications	
Pressure-Temperature Ratings	19
EXCO-F Series Quality Control	23
EXCO-F Series valves quality control	
Precautions in usage with EXCO-F Series valves	
Handling precautions for EXCO-F Series valves	
EXCO-F Series Lineups	25



UTSUE VALVE CO., LTD. recognizes that preserving the earth environment is one of the most important subjects of human community and endeavors with its every organization to decrease environmental burden.

NPO KES ENVIRONMENTAL ORGANIZATION



Safety Precautions

- Select proper valves to meet your requirements within your authority and on your responsibility.
- Read the Instruction Manual carefully to handle valves properly and safely before using the equipments.
- Improper handling can lead to product damage or breakdown.
- (Facing the valve) Turn the handwheel clockwise to CLOSE the valve and counter-clockwise to OPEN it.
- Keep valves either fully opened or fully closed. (Not required with needle valves)
- Contact Utsue Valve when flow-regulating valves or other types of control valves are required
- Do not use more than the limited tightening torque when shutting hand-operated valves are required.
- Turn handwheels backward 1/4 to 1/2 turn after fully opening valve. (For gate valves and globe valves)
- Flow direction of globe and check valves is restricted to oneway traffic.
- Check medium flow direction before installing valves.
- We recommend valves be handled and operated only by qualified persons who are familiar with product specifications.

Everything from Taking Orders to Aftercare Service

System

We make every effort to ensure that you get the equipment you need and that it works properly. Any information from taking orders to aftercare service is accurately linked with computer network system.

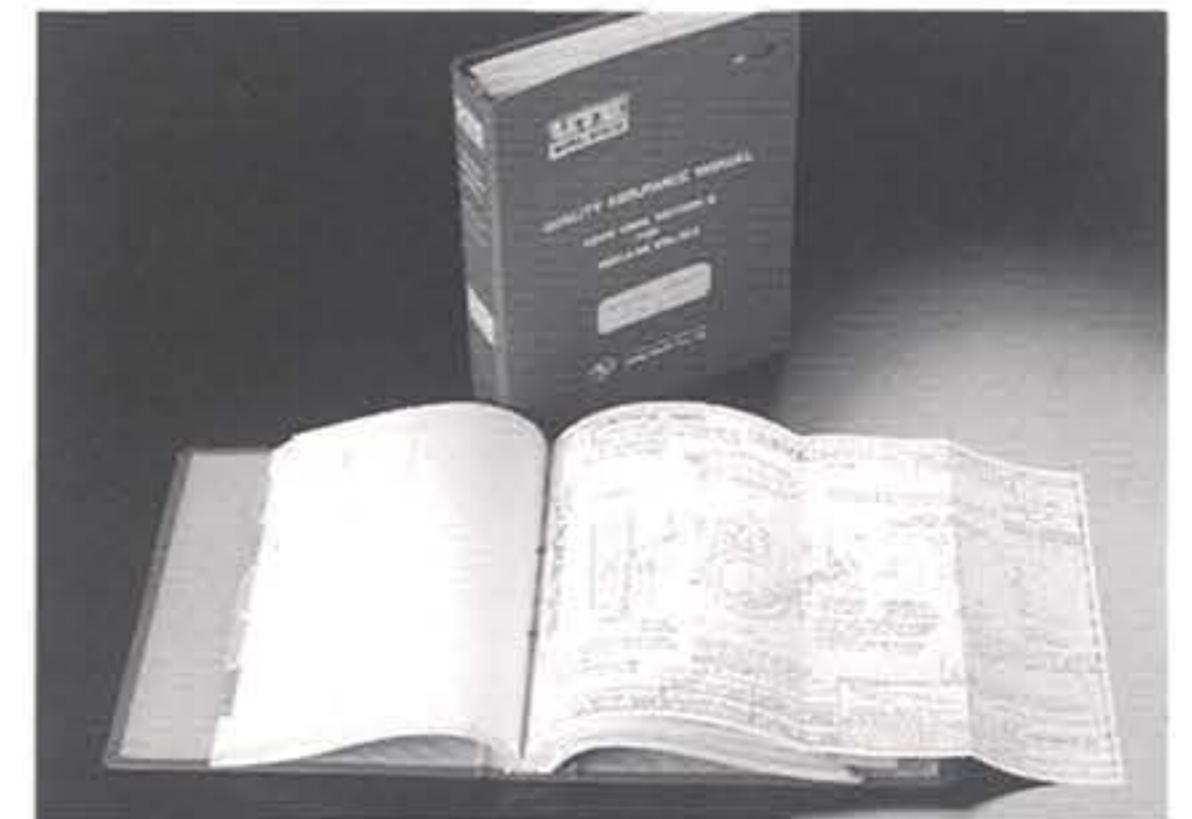

•QA manual

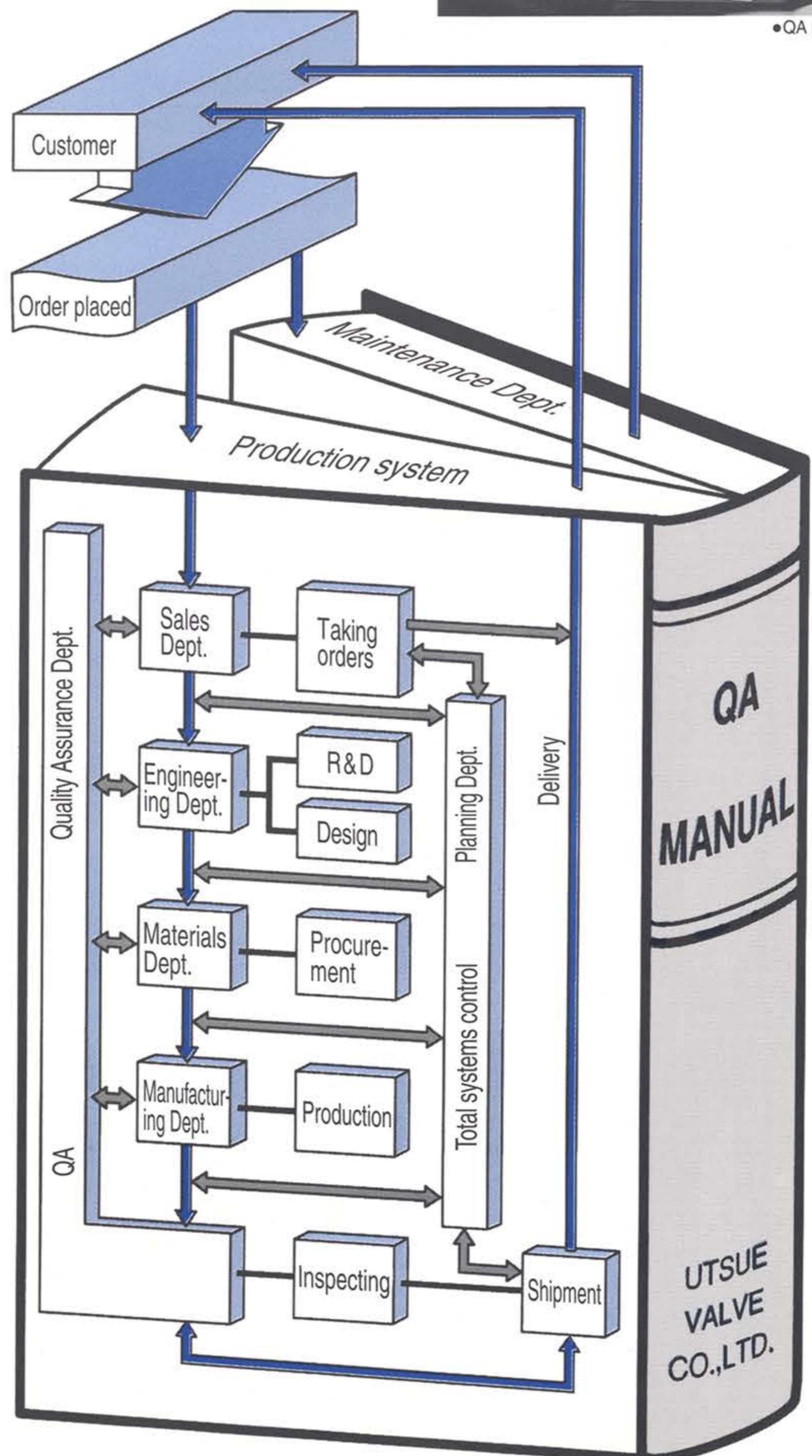

EXCO-F

FORGED STEEL

**GATE
GLOBE
CHECK
VALVES**

EXCO-F Forged Steel Valves

● Please use the below type Nos. when ordering or inquiring about EXCO-F Series valves.

Valve type	Pressure class	Type No.	Remark
Gate	800	E115	Standard port
		E215	Full port
Globe	600	E135	Standard port
		E235	Full port
Globe	1500	E137	Standard port
	2500	E139	
	4500	E13C	
Check	600	E155	Standard port
		E255	Full port



Type E115/E215

Valve type No. coding system

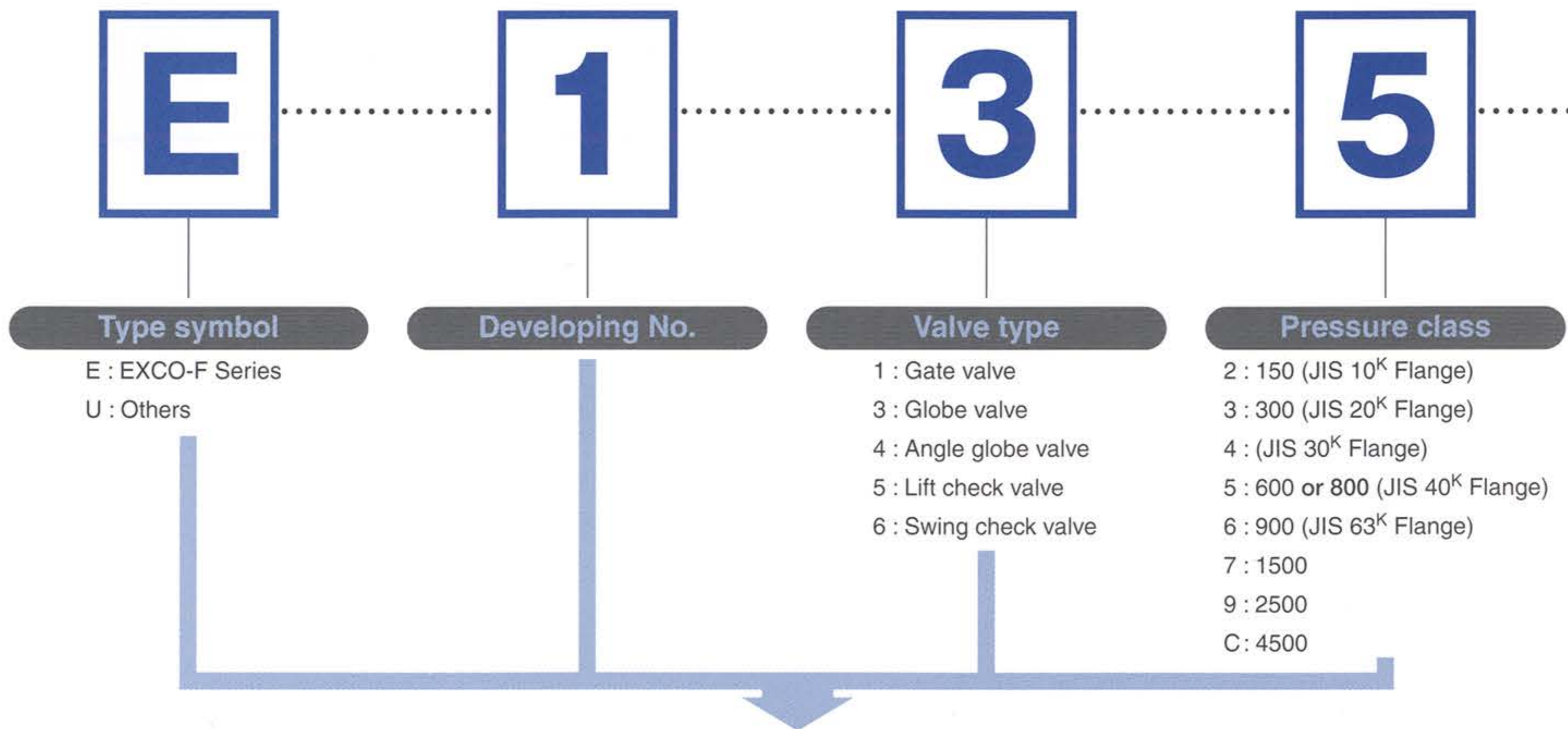

Class	Developing No.		Valve type										
	1 Standard port	2 Full port	3	4	5	6	7	9	H				
600 or 800 (WG)	1 Gate valve	E115	E215										
	3 Globe valve	E135	E235				E635 With position indicator	E735 Parabolic with position indicator	E935 Screw down stop check				UH35 Needle with position indicator
	4 Angle valve	E145											UH45 Needle with position indicator
	5 Lift check valve	E155	E255	E355 Spring-loaded	E455 Full port Spring-loaded	E555 For small press. diff.	E655 Full port For small press. diff.						
	6 Swing check valve				E465								
900	1 Gate valve	E116											
	3 Globe valve	E136				E536 Needle with position indicator	E636 With position indicator	E736 Parabolic with position indicator	E936 Screw down stop check				
	4 Angle valve	E146				E546 Needle with position indicator	E646 With position indicator						
	5 Lift check valve	E156											
1500	3 Globe valve	E137		E337 Instrument valve		E537 Needle with position indicator	E637 With position indicator	E737 Parabolic with position indicator					
	4 Angle valve	E147				E547 Needle with position indicator	E647 With position indicator						
	5 Lift check valve	E157											
2500	3 Globe valve	E139		E339 Instrument valve		E539 Needle with position indicator	E639 With position indicator	E739 Parabolic with position indicator					
	4 Angle valve	E149				E549 Needle with position indicator	E649 With position indicator						
	5 Lift check valve	E159											
4500	3 Globe valve	E13C											

● Colored areas are listed in this catalog.
● For instrument valves, see catalog No. 1885JE.



Type E135/E235



Type E155/E255



Type E137/E139



Type E13C

5

Joint

- 1 : Butt welding
- 2 : ASME Flange
- 3 : JIS Flange
- 4 : Ring joint
- 5 : Socket welding (JIS)
- 6 : Screwed type (Rc)
- 7 : Socket welding (ASME)
- 8 : Screwed type (NPT)
- 9 : API, etc.

5

Size

- 51 : 6A (3/8OD)
- 52 : 8A (1/4B)
- 53 : 10A (3/8B)
- 54 : 15A (1/2B)
- 55 : 20A (3/4B)
- 56 : 25A (1B)
- 57 : 32A (1 1/4B)
- 58 : 40A (1 1/2B)
- 59 : 50A (2B)

9

Material

- A : S28C
- C : SFVA F11A
- D : SFVA F22B
- K : SUSF304
- L : SUSF316
- G : SUSF304L
- T : ASTM A105
- V : ASTM A182 F11
- W : ASTM A182 F22
- Q : ASTM A182 F304
- R : ASTM A182 F316
- H : ASTM A182 F304L
- Y : SFVC2A
- X : Special

A

E

Special specification

- Without symbol : Standard
- E : Motor operated

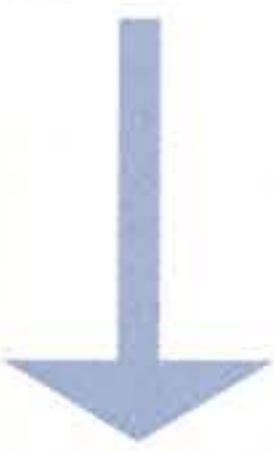

Joint end

Socket welding end

- ASME
- JIS

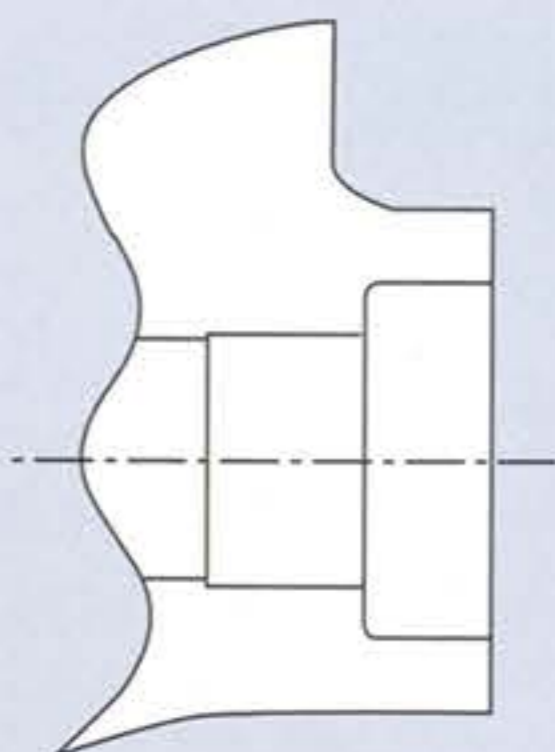

Threaded end

- NPT
- Rc (PT)

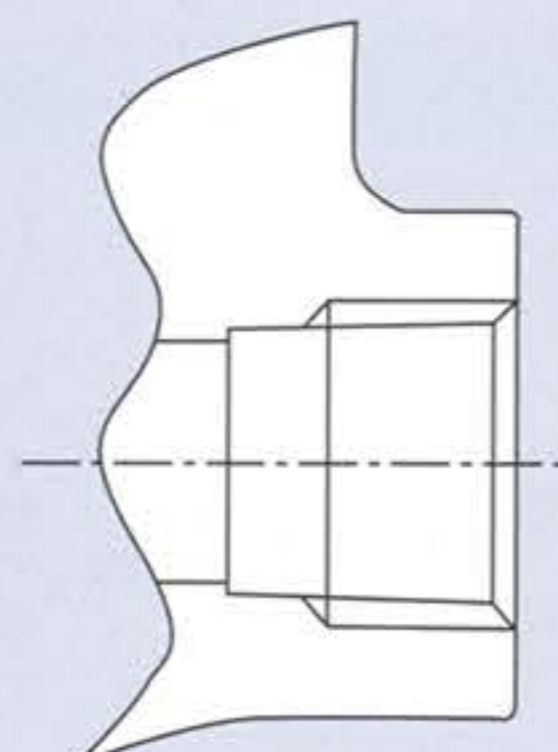

Flanged end

- ASME
- API
- JIS

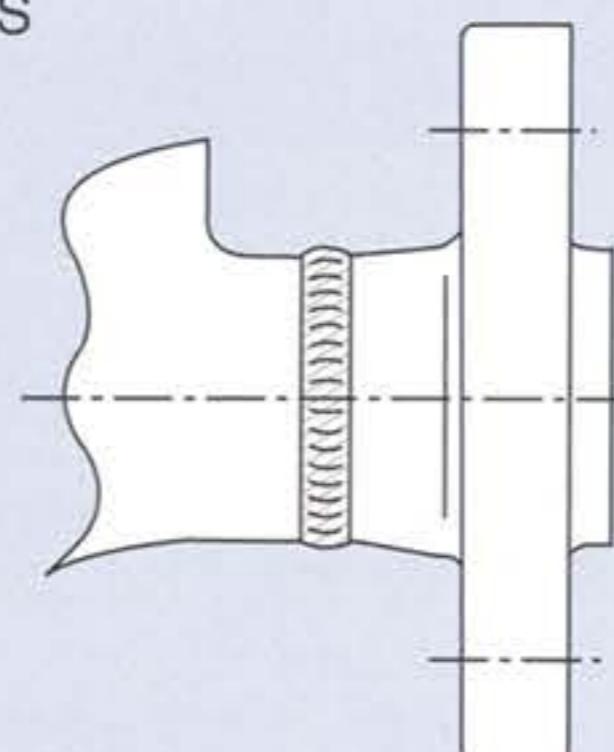

Butt welding end

- Specify type, dimension, etc. when ordering.

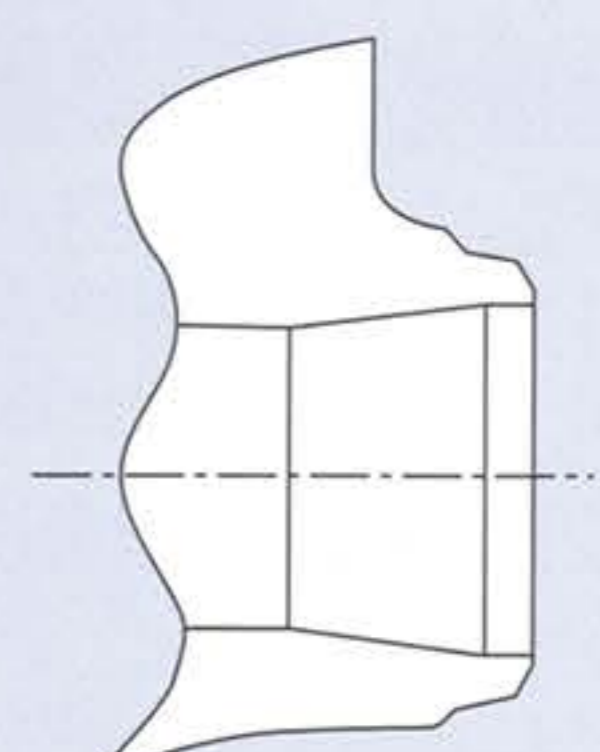

EXCO-F (Class 800) Gate Valve

Type **E115** ● Standard port type / **E215** ● Full port type

● Valve size: 1/4 B~2B

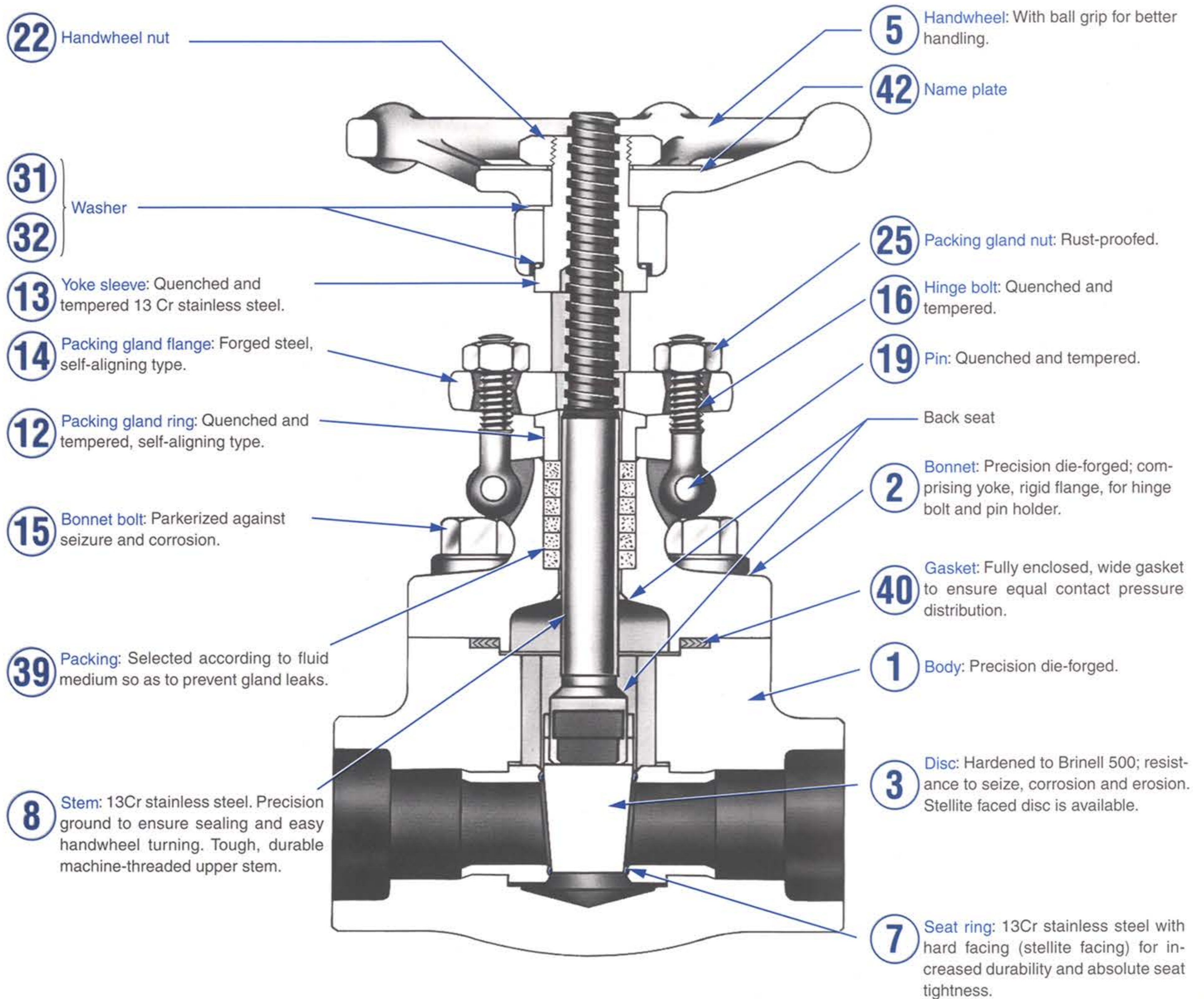

● Standard materials (Carbon steel)

Mark	Part name	Material	Mark	Part name	Material	Mark	Part name	Material
1	Body	ASTM A105	13	Yoke sleeve	SUS416	31	Washer	SK85
2	Bonnet	ASTM A105	14	Packing gland flange	S25C	32	Washer	SK85
3	Disc	SUS420J2	15	Bonnet bolt	SNB7	39	Packing	Graphite with stainless wire
5	Handwheel	FCMB270	16	Packing gland bolt	SUS410	40	Gasket	Graphite · Stainless hoop
7	Seat ring	SUS410	19	Pin	SUS410	42	Nameplate	Aluminum alloy
8	Stem	SUS416	22	Handwheel nut	SS400			
12	Packing gland ring	SUS416	25	Packing gland nut	S45C			

● Other body/bonnet materials
Low alloy steel
Stainless steel



- Outside screw and yoke (OS & Y)
- Bolted bonnet (BB)
- Hard faced disc and seat ring

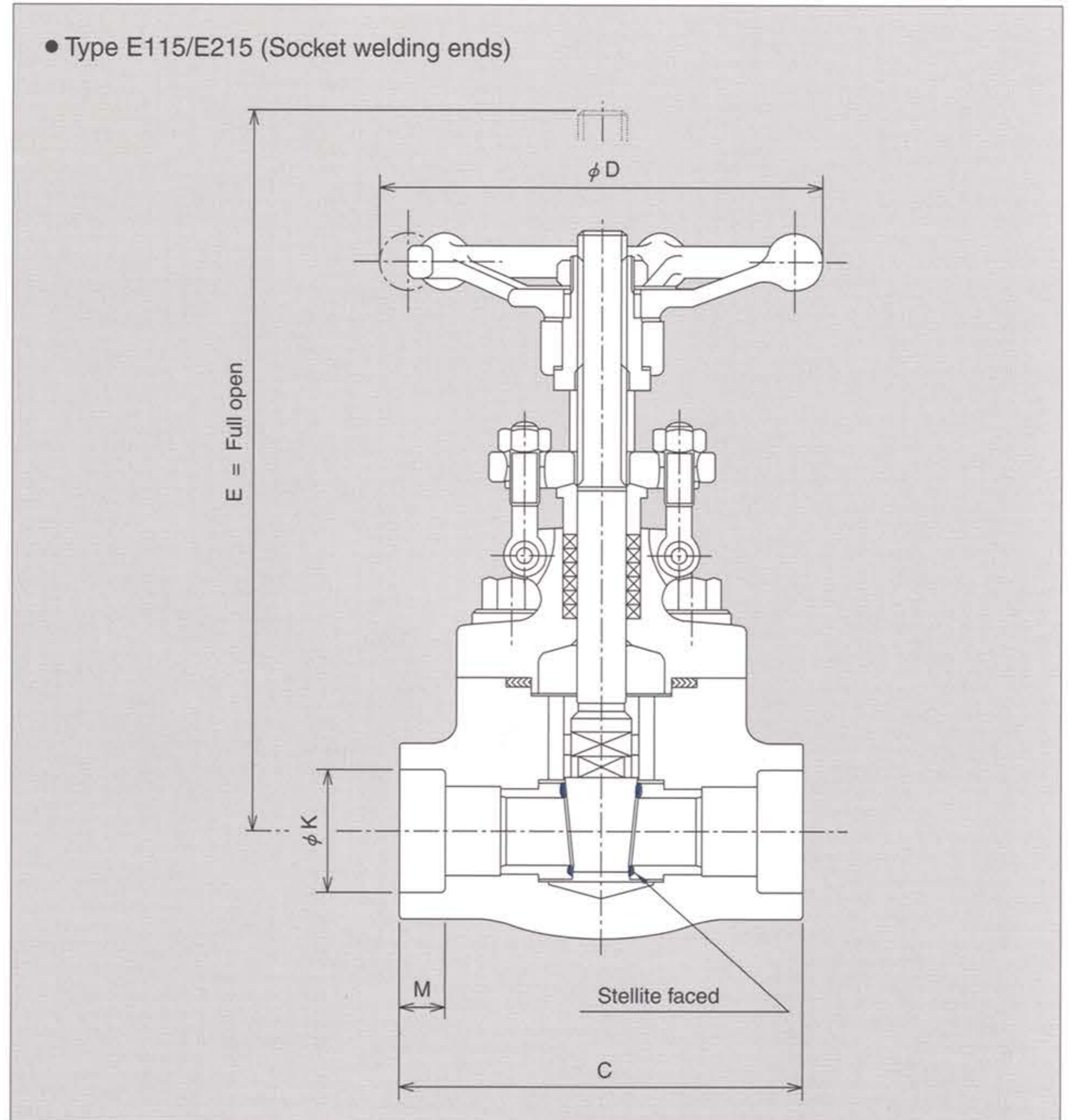

● Standard dimensions (mm) and weight (kg)

Valve size		Socket inside dia. K	Socket depth M	Thread size B	Type E115				Type E215			
A	B				End-to-end distance C	Handwheel dia. D	Height (Full open) E	Weight	End-to-end distance C	Handwheel dia. D	Height (Full open) E	Weight
8	1/4	14.3	13.0	1/4	84	95	139	1.9	—	—	—	—
10	3/8	17.8	13.0	3/8	84	95	139	1.9	—	—	—	—
15	1/2	22.2	13.0	1/2	84	95	139	1.9	90	110	149	2.2
20	3/4	27.7	13.0	3/4	90	110	149	2.2	114	125	187	4.0
25	1	34.5	13.0	1	114	125	187	4.0	121	155	218	5.0
32	1 1/4	43.2	13.0	1 1/4	121	155	236	7.4	130	180	265	10.5
40	1 1/2	49.1	13.0	1 1/2	121	155	236	7.4	130	180	265	10.5
50	2	61.1	15.9	2	130	180	265	10.5	156	200	340	15.0

● For flange end-to-end distance, see page 14.

EXCO-F (Class 600) Globe Valve

Type **E135** ● Standard port type / **E235** ● Full port type

● Valve size: 1/4 B~2B

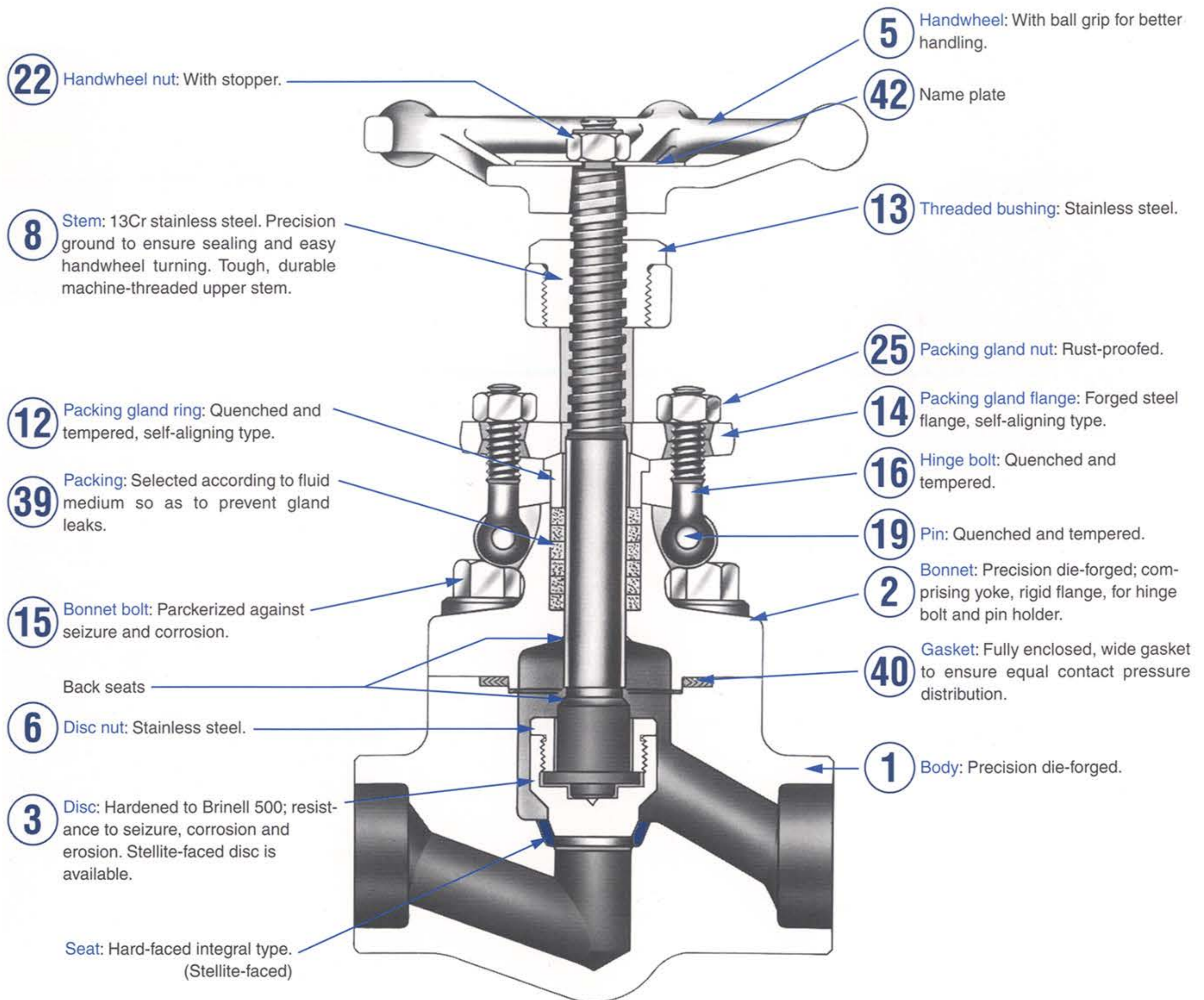

● Standard materials (Carbon steel)

Mark	Part name	Material	Mark	Part name	Material	Mark	Part name	Material
1	Body	ASTM A105	12	Packing gland ring	SUS416	22	Handwheel nut	S15C
2	Bonnet	ASTM A105	13	Thread bushing	SUS416	25	Packing gland nut	S45C
3	Disc	SUS420J2	14	Packing gland flange	S25C	39	Packing	Graphite with stainless wire
5	Handwheel	FCMB270	15	Bonnet bolt	SNB7	40	Gasket	Graphite · Stainless hoop
6	Disc nut	SUS416	16	Packing gland bolt	SUS410	42	Nameplate	Aluminum alloy
8	Stem	SUS416	19	Pin	SUS410			

● Other body/bonnet materials
 Low alloy steel
 Stainless steel



- Outside screw and yoke (OS & Y)
- Bolted bonnet (BB)
- Hard faced disc and body seats

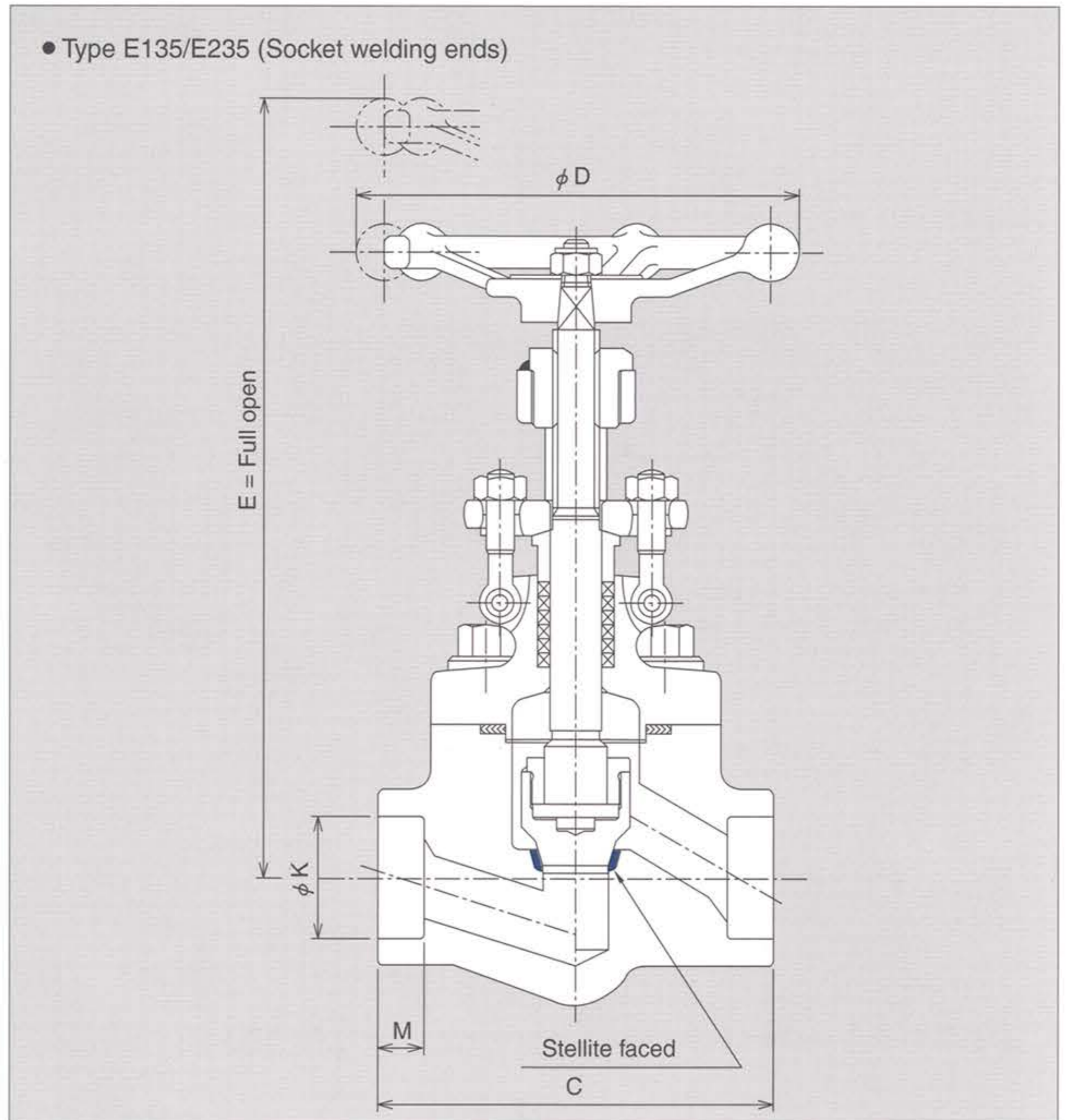

● Standard dimensions (mm) and weight (kg)

Valve size		Socket inside dia. K	Socket depth M	Thread size B	Type E135				Type E235			
A	B				End-to-end distance C	Handwheel dia. D	Height (Full open) E	Weight	End-to-end distance C	Handwheel dia. D	Height (Full open) E	Weight
8	1/4	14.3	13.0	1/4	84	95	145	1.8	—	—	—	—
10	3/8	17.8	13.0	3/8	84	95	145	1.8	—	—	—	—
15	1/2	22.2	13.0	1/2	84	95	145	1.8	90	110	158	2.1
20	3/4	27.7	13.0	3/4	90	110	158	2.1	111	125	198	3.8
25	1	34.5	13.0	1	111	125	198	3.8	133	155	231	4.9
32	1 1/4	43.2	13.0	1 1/4	165	155	238	7.8	178	180	275	11.2
40	1 1/2	49.1	13.0	1 1/2	165	155	238	7.8	178	180	275	11.2
50	2	61.1	15.9	2	178	180	275	11.2	228	200	338	17.6

● For flange end-to-end distance, see page 14.

EXCO-F (Class 1500/2500) Globe Valve

Type **E137** (Class 1500) ● Standard port type / **E139** (Class 2500) ● Standard port type

● Valve size: 1/4 B ~ 2B

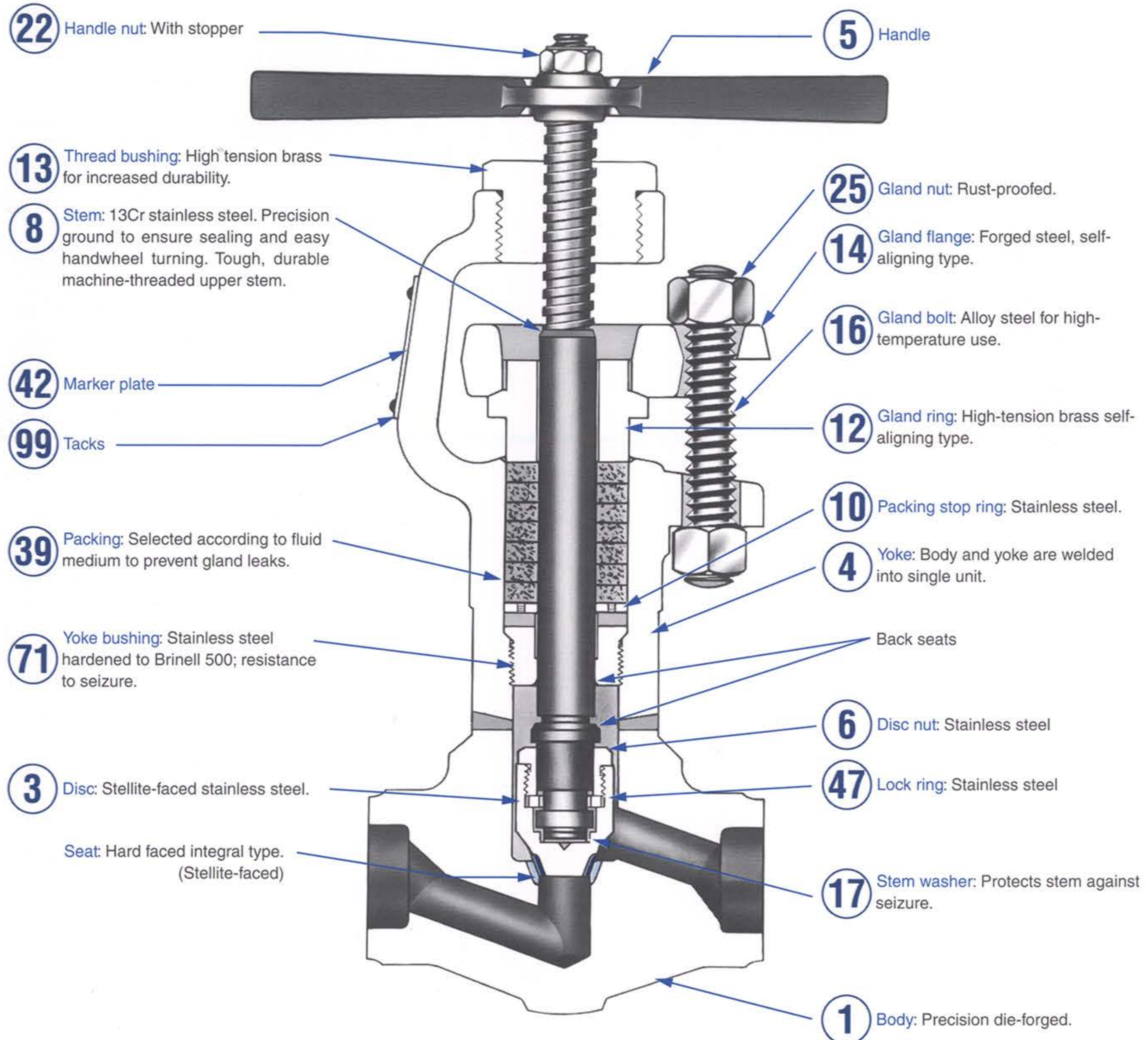

● Standard materials (Carbon steel)

Mark	Part name	Material	Mark	Part name	Material	Mark	Part name	Material
1	Body	ASTM A105	12	Gland ring	C6782BE	39	Packing	Graphite with Inconel wire
3	Disc	SUS403	13	Thread bushing	C6782BE	42	Nameplate	Copper alloy
4	Yoke	ASTM A105	14	Gland flange	SCM435	47	Lock ring	SUS403
5	Handle	FCMB270	16	Gland bolt	SNB7	71	Yoke bush nut	SUS420J2
6	Disc nut	SUS403	17	Stem washer	H-25	99	Tack	C3771BE
8	Stem	SUS403	22	Handle nut	S15C			
10	Packing stop ring	SUS416	25	Gland nut	S45C			

● Other body/bonnet materials
Low alloy steel
Stainless steel



*Handwheel model is available.

- Outside screw and yoke (OS & Y)
- Body/yoke integral type
- Hard faced disc and body seats

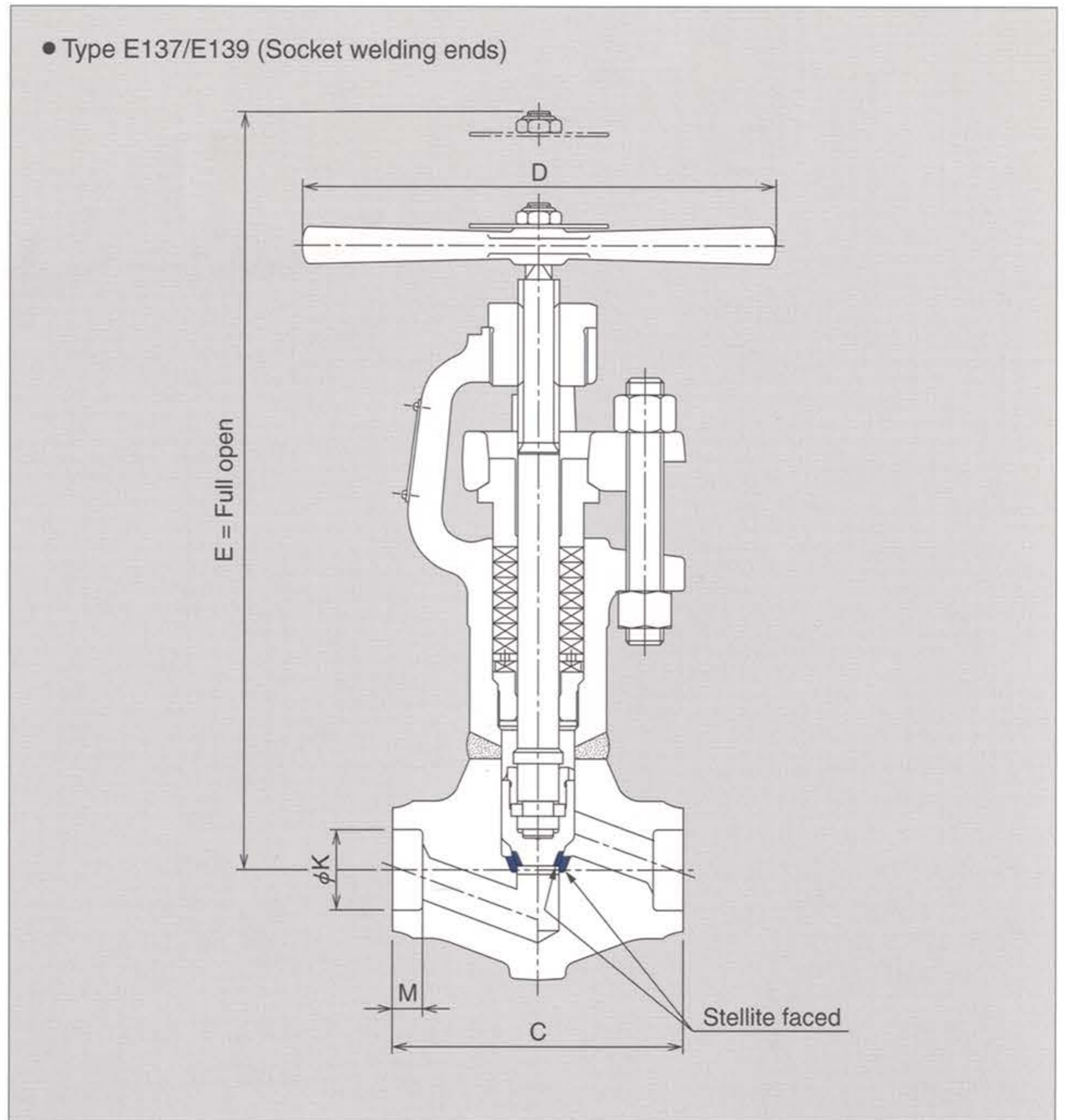

● Standard dimensions (mm) and weight (kg)

Valve size		Socket inside dia. K	Socket depth M	End-to-end distance C	Handle length D	Type E137		Type E139	
A	B					Height (Full open) E	Weight	Height (Full open) E	Weight
8	1/4	14.3	13.0	127	181	261	5.4	261	5.4
10	3/8	17.8	13.0	127	181	261	5.4	261	5.4
15	1/2	22.2	13.0	127	181	261	5.4	261	5.4
20	3/4	27.7	13.0	127	206	301	8.6	301	8.6
25	1	34.5	13.0	127	206	301	8.6	301	8.6
32	1 1/4	43.2	13.0	216	318	415	23.1	422	26.3
40	1 1/2	49.1	13.0	216	318	415	23.1	422	26.3
50	2	61.1	15.9	216	318	435	25.0	452	29.4

EXCO-F Ultra High Pressure (Class 4500) Globe Valve

Type **E13C** (Class 4500)

● Valve size: 1/4 B~2B

See pages 19~22 for PRESSURE – TEMPERATURE RATINGS.



- Outside screw and yoke (OS & Y)
- Body / yoke integral type
- Hard faced disc and body seats

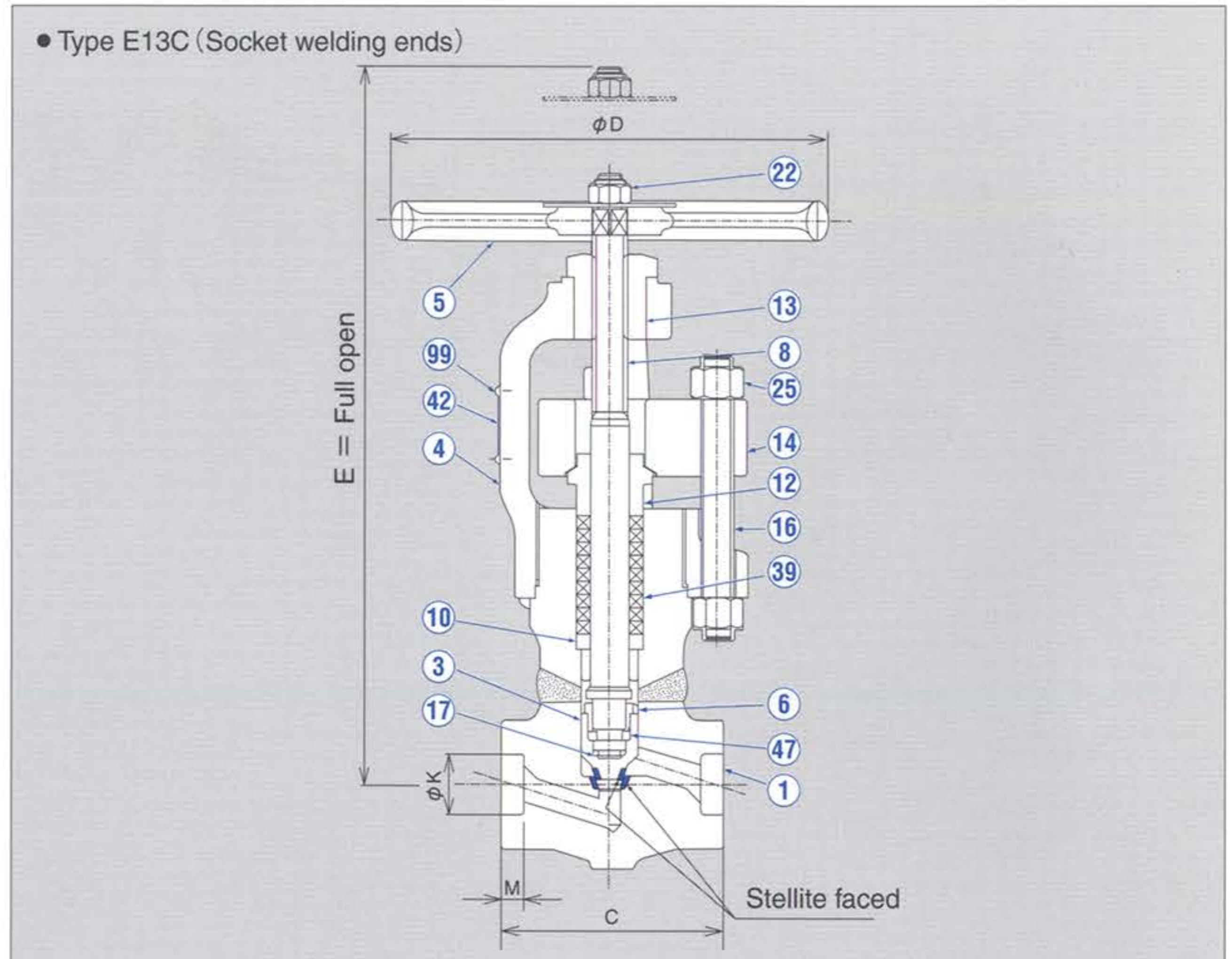

● Standard materials (Low alloy steel)

Mark	Part name	Material	Mark	Part name	Material	Mark	Part name	Material
1	Body	ASTM A182 F22	10	Packing stop ring	SUS403	22	Handwheel nut	S15C
3	Disc	SUS316	12	Packing gland ring	C6782BE	25	Packing gland nut	S45C
4	Yoke	SCPH32	13	Thread bushing	C6782BE	39	Packing	Graphite with Inconel wire
5	Handwheel	FCMB270	14	Packing gland flange	S25C	42	Nameplate	Copper alloy
6	Disc nut	SUS403	16	Packing gland bolt	SNB7	47	Lock ring	SUS403
8	Stem	SUS403	17	Stem washer	H-25	99	Tack	C3771BE

- Other body/bonnet materials
 Low alloy steel
 Stainless steel

● Standard dimensions (mm) and weight (kg)

Valve size		Socket inside dia. K	Socket depth M	End-to-end distance C	Handwheel dia. D	Height (Full open) E	Weight
A	B						
8	1/4	14.3	13.0	127	200	308	10.6
10	3/8	17.8	13.0	127	200	308	10.6
15	1/2	22.2	13.0	127	200	308	10.6
20	3/4	27.7	13.0	127	250	367	20.0
25	1	34.5	13.0	127	250	367	20.0
32	1 1/4	43.2	13.0	216	350	477	52.0
40	1 1/2	49.1	13.0	216	350	477	52.0
50	2	61.1	15.9	216	350	477	52.0

EXCO-F (Class 600) Check Valve

Type **E155** ● Lift type Standard port / **E255** ● Lift type Full port / **E465** ● Swing type Full Port ● Valve size: 1/4 B~2B

See pages 19~22 for PRESSURE – TEMPERATURE RATINGS.

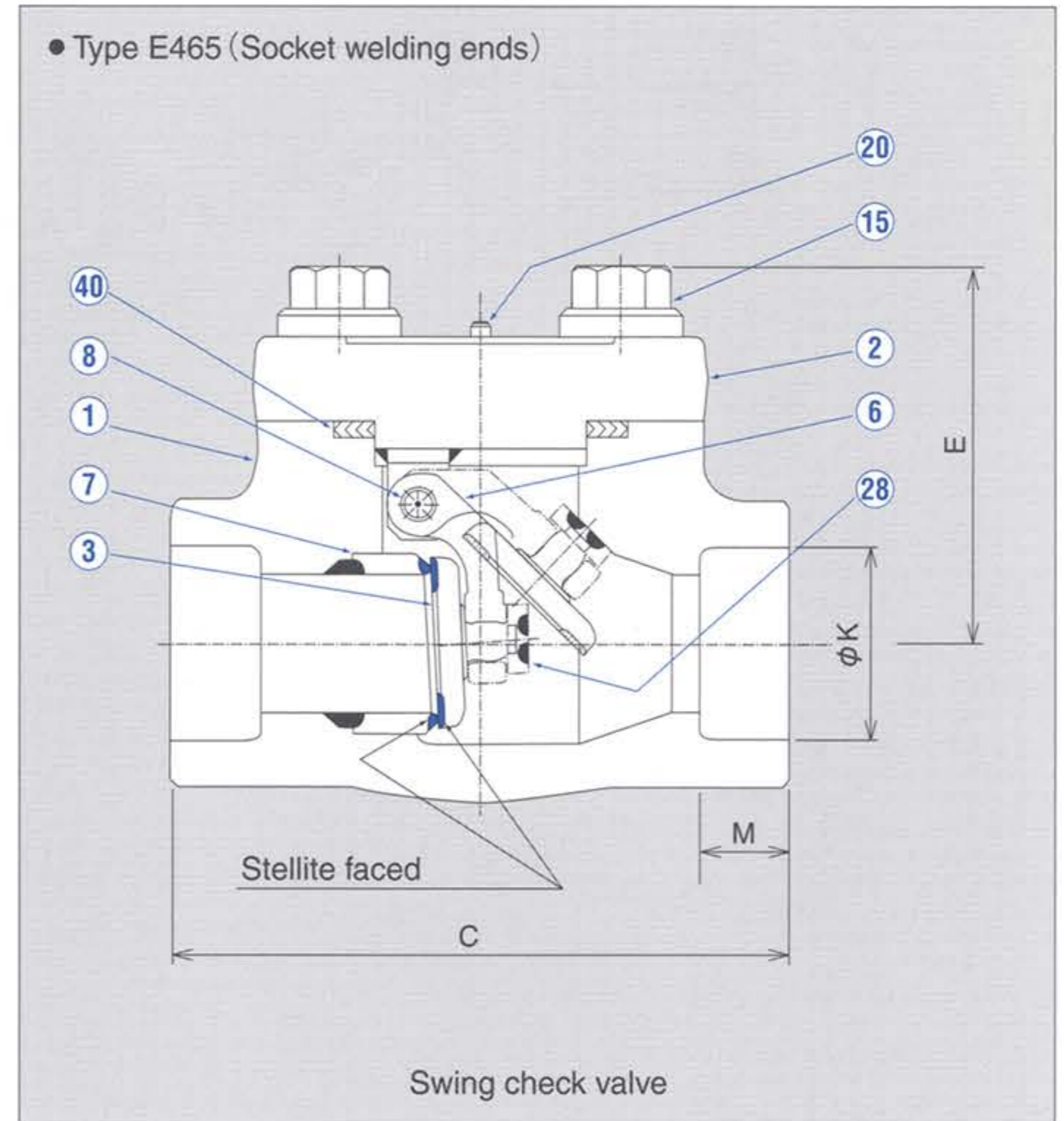
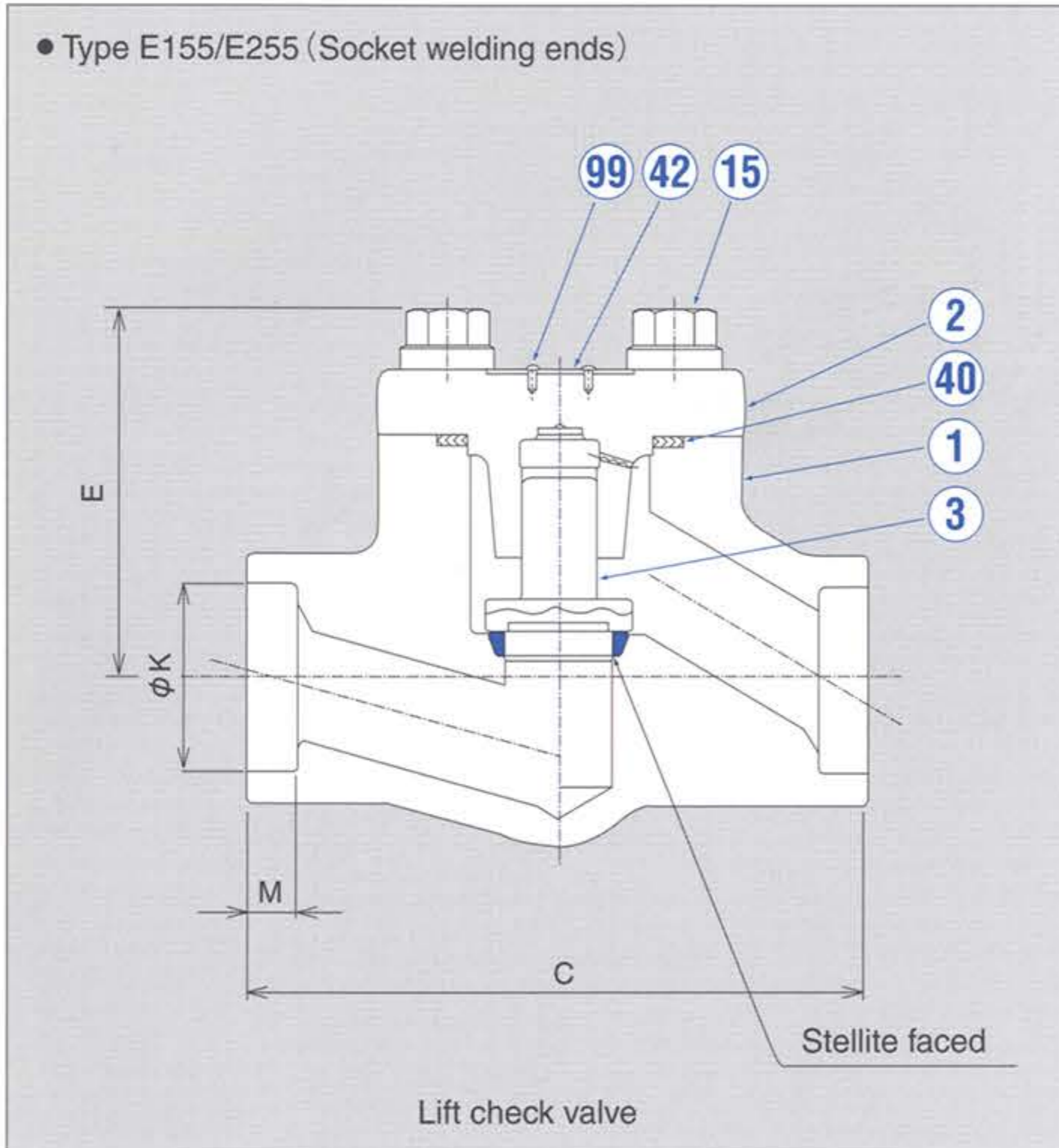

● Standard materials

● Type E155/E255 (Carbon steel) ● Type E465 (Carbon steel)

Mark	Part name	Material	Mark	Part name	Material	Mark	Part name	Material
1	Body	ASTM A105	1	Body	ASTM A105	20	Taper pin	SUS304
2	Bonnet	ASTM A105	2	Bonnet	ASTM A105	28	Disc lock fittings	S25C
3	Disc	SUS420J2	3	Disc	S25C	40	Gasket	Graphite · Stainless hoop
15	Bonnet bolt	SNB7	6	Arm	SCS14A			
40	Gasket	Graphite · Stainless hoop	7	Seat ring	S25C			
42	Nameplate	Aluminum alloy	8	Spindle	SUS316			
99	Tack	C3771BE	15	Bonnet bolt	SNB7			

● Standard dimensions (mm) and weight (kg)

Valve size		Socket inside dia. K	Socket depth M	Screw size B	Type E155			Type E255			Type E465		
A	B				End-to-end distance C	Height E	Weight	End-to-end distance C	Height E	Weight	End-to-end distance C	Height E	Weight
8	1/4	14.3	13.0	1/4	84	48	1.1	—	—	—	—	—	—
10	3/8	17.8	13.0	3/8	84	48	1.1	—	—	—	—	—	—
15	1/2	22.2	13.0	1/2	84	48	1.1	90	54	1.4	90	55	1.5
20	3/4	27.7	13.0	3/4	90	54	1.4	111	71	2.4	90	55	1.5
25	1	34.5	13.0	1	111	71	2.4	133	92	3.6	114	72	2.7
32	1 1/4	43.2	13.0	1 1/4	165	97	6.0	178	118	10.0	121	108	5.2
40	1 1/2	49.1	13.0	1 1/2	165	97	6.0	178	118	10.0	130	120	7.8
50	2	61.1	15.9	2	178	118	10.0	228	145	15.2	156	151	11.5

● For flange end-to-end distance, see page 14.

EXCO-F (Class 600) Flow Rate Control Valve

Type **E735** ● Parabolic disc type / **UH35** ● Needle type

● Type E735 (Socket welding ends)

Position indicator (Option)

E = Full open

ϕD

ϕK

M

C

Stellite faced

Standard globe valve (E135) with parabolic-shaped disc and improved flow control. Select UH35 for severe flow condition. It is also available with position indicator.

Flow rate characteristic

● Type UH35 (Socket welding ends)

Position indicator

E = Full open

ϕD

ϕK

M

C

Stellite faced

Narrower seat orifice and integrated stem-disc for improved vibration resistance and controllability. Stem is stellite-faced near tip for higher erosion resistance. Position indicator marked by 1/10 turn increments consists of standard equipment.

Flow rate characteristic

● Standard dimensions (mm) and weight (kg)

● Type UH35 (Type E735 data are the same as Type E135. See page 8.)

Valve size		Socket inside dia. K	Socket depth M	End-to-end distance C	Hand-wheel dia. D	(Note) Height (Full open) E	Weight
A	B						
15	1/2	22.2	13.0	90	110	162	2.1
20	3/4	27.7	13.0	111	125	193	4.1
25	1	34.5	13.0	165	155	236	5.2
40	1 1/2	49.1	13.0	178	180	281	11.5
50	2	61.1	15.9	228	200	337	17.9

● Full open Cv-value

Valve size	Type E735	Type UH35 (Standard)		
		Orifice I	Orifice II	Orifice III
15 A	1.2	0.2	0.4	1.0
20 A	3.2	0.58	1.0	2.4
25 A	5.8	1.2	2.9	5.9
40 A	14	6.0	11	18
50 A	22	6.0	14	22

● To ensure the best valve for your flow conditions, inform needle valve specifications listed on page 18.
Note: Height (E) varies according to orifice size. Table figures given as reference only.

End-to-End Distance on Flanged Valves

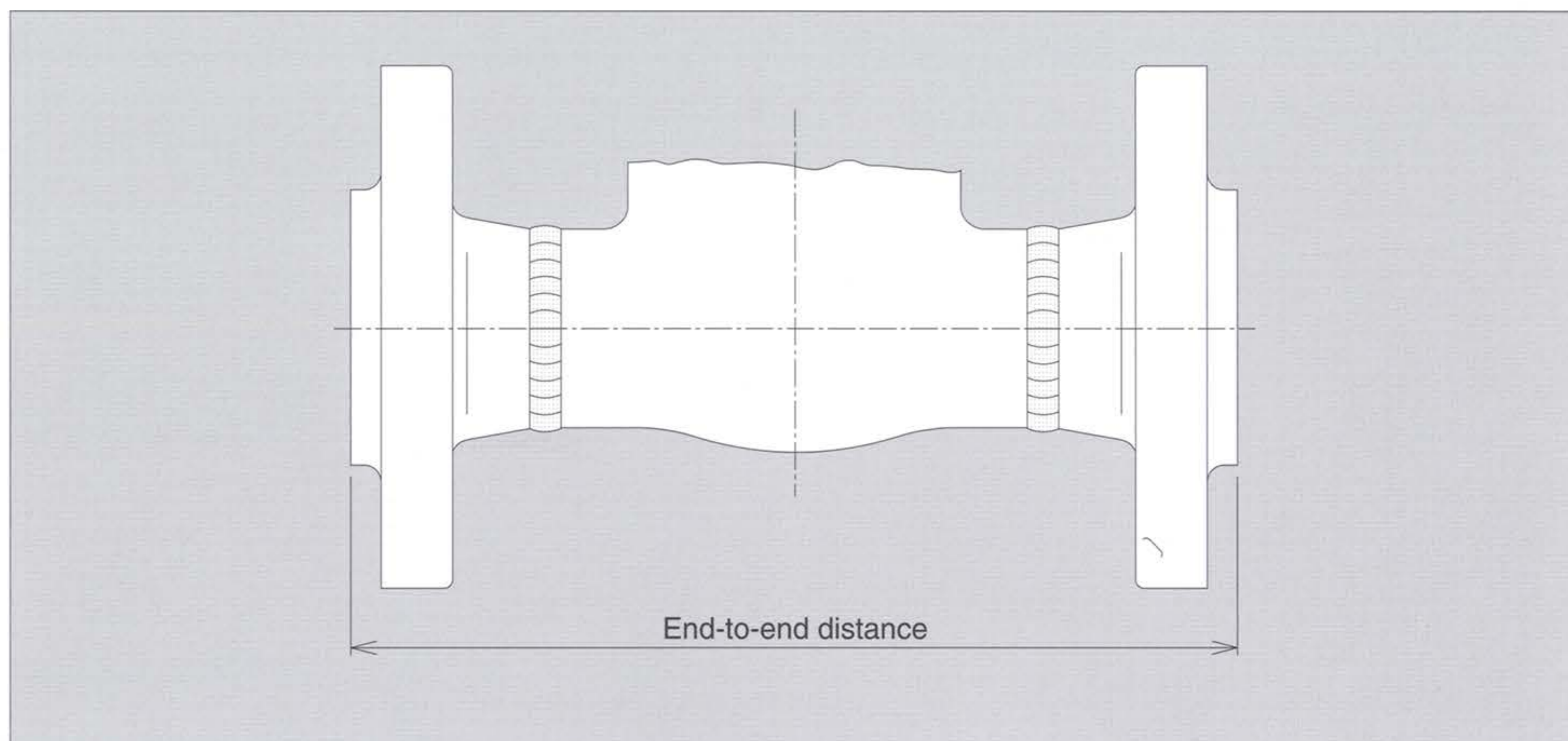

● Standard port type

(Unit:mm)

Type Flange Valve size	E115						E135/E735/E155					
	ASME	JPI	JIS	ASME	JPI	JIS	ASME	JPI	JIS	ASME	JPI	JIS
	150 300		10K 20K	600		30K 40K	150 300		10K 20K	600		30K 40K
15 A	152		165		165		152		165		165	
20 A	178		190		190		178		190		190	
25 A	203		216		216		203		216		216	
40 A	190		241		241		229		241		241	
50 A	216		292		292		267		292		292	

● Full port type

(Unit:mm)

Type Flange Valve size	E215						E235/E255						
	ASME	JPI	JIS	ASME	JPI	JIS	ASME	JPI	JIS	ASME	JPI	JIS	
	150 300		10K 20K	600		30K 40K	150 300		10K 20K	600		30K 40K	
15 A	158		165		165		158		165		165		
20 A	202		190		190		199		212		212		
25 A	210		216		216		225		238		238		
40 A	※	190		241		242		254		254		254	
50 A	242		318		318		317		342		342		

※Note: CLASS 150 applies to 190, CLASS 300 applies 229.

●Hydrostatic pressure test

●Materials

ASME materials group	Steel type	Material
1.1	Carbon steel	S28C, SFVC2A, ASTM A105, SCPH2, ASTM A216 WCB
1.9	1-¼Cr-½Mo	SFVA F11A, ASTM A182 F11 Class2, SCPH21, ASTM A217 WC6
1.10	2-¼Cr-1Mo	SFVA F22B, ASTM A182 F22 Class3, SCPH32, ASTM A217 WC9
1.15	9Cr-1Mo-V	火SFVA F28, ASTM A182 F91, 火SCPH91, A217 C12A
2.1	18Cr-8Ni	SUSF304, ASTM A182 F304, SCS13A, SCS19A
2.2	16Cr-12Ni-2Mo	SUSF316, ASTM A182 F316, SCS14A, SCS16A
2.3	16Cr-12Ni-2Mo(LC)	SUSF316L, ASTM A182 F316L
	18Cr-8Ni(LC)	SUSF304L, ASTM A182 F304L

●ASME Hydrostatic test pressure on Standard class (MPa)

ASME materials group	Class 150		Class 300		Class 600		Class 800	
	Shell test	Closure test	Shell test	Closure test	Shell test	Closure test	Shell test	Closure test
1.1	3.0	2.2	7.7	5.7	15.4	11.3	20.5	15.0
1.9 & 1.10 & 1.15	3.0	2.2	7.8	5.7	15.6	11.4	20.7	15.2
2.1 & 2.2	2.9	2.1	7.5	5.5	14.9	11.0	19.9	14.6
2.3	2.4	1.8	6.3	4.6	12.5	9.1	16.6	12.2

ASME materials group	Class 900		Class 1500		Class 2500		Class 4500	
	Shell test	Closure test	Shell test	Closure test	Shell test	Closure test	Shell test	Closure test
1.1	23.0	16.9	38.3	28.1	63.9	46.9	* 114.9	* 84.3
1.9 & 1.10 & 1.15	23.3	17.1	38.8	28.5	64.7	47.4	* 116.4	* 85.4
2.1 & 2.2	22.4	16.4	37.3	27.4	62.1	45.6	* 111.7	* 82.0
2.3	18.7	13.7	31.1	22.8	51.8	38.0	* 93.1	* 68.3

Note: Table figures conform to ASME B16.34

*Upper limit pressure given for hydraulic test where marked with *. Unless specified, shell test pressure is set as 2 times max. working pressure, and seat as 1.5 times max. working pressure.

●JIS Hydrostatic test pressure of valve with flanges (MPa)

JIS 10K		JIS 16K		JIS 20K		JIS 30K		JIS 40K	
Shell test	Closure test	Shell test	Closure test	Shell test	Closure test	Shell test	Closure test	Shell test	Closure test
2.1	1.6	4.1	3.0	5.1	3.8	7.7	5.7	10.2	7.5

Note: Table figures conform to JIS B 2220.

●JPI Hydrostatic test pressure (MPa)

ASME materials group	Class 150		Class 300		Class 600		Class 800	
	Shell test	Closure test	Shell test	Closure test	Shell test	Closure test	Shell test	Closure test
1.1	3.10	2.16	7.76	5.61	15.34	11.22	20.51	14.98
1.9 & 1.10 & 1.15	3.10	2.20	7.76	5.69	15.51	11.38	20.68	15.17
2.1 & 2.2	2.93	2.09	7.58	5.46	15.00	10.92	19.99	14.56
2.3	2.41	1.74	6.21	4.55	12.41	9.10	16.55	12.13

ASME materials group	Class 900		Class 1500		Class 2500	
	Shell test	Closure test	Shell test	Closure test	Shell test	Closure test
1.1	23.10	16.84	38.44	28.10	63.95	46.79
1.9 & 1.10 & 1.15	23.27	17.06	38.78	28.44	64.64	47.40
2.1 & 2.2	22.41	16.38	37.23	27.30	62.05	45.51
2.3	18.62	13.65	31.03	22.75	51.71	37.92

Note: Table figures conform to JPI 7S-39.

Engineering sheet

Formulas for calculating Cv

Liquid

$$\frac{0.3656 Q \sqrt{G}}{\sqrt{\Delta p}}$$

Gas

$$\frac{Q \sqrt{G}}{173.3 \sqrt{\Delta p (p_1 + p_2)}}$$

Temperature correction (over 60°C)

$$\frac{Q \sqrt{G} (492 + 9T/5)}{3955 \sqrt{\Delta p (p_1 + p_2)}}$$

Saturated Steam

$$\frac{W}{138.1 \sqrt{\Delta p (p_1 + p_2)}}$$

Superheated Steam

$$\frac{(1 + 0.00126 T_{SH}) W}{138.1 \sqrt{\Delta p (p_1 + p_2)}}$$

● Symbols

- Q : Flow rate of fluid (m³/H)/gas (Nm³/H)
 W : Steam flow rate (kg/H)
 p_1 : Inlet pressure (MPa abs)
 p_2 : Outlet pressure (MPa abs)
 Δp : Pressure difference (MPa)
 G : Specific gravity ... Liquids : Water = 1.0
 Gas: Air = 1.0
 T_{SH} : Degree of superheat (°C) ...
 Temperature of super-heated steam —
 Temperature of saturated steam that
 shows same pressure as the super-
 heated steam
 T : Temperature (°C)

● Notes

- Cv correction is needed with liquids when evaporated after decompression (e.g.: saturated water).
- Cv correction is needed if the coefficient of kinematic viscosity for the liquid is over 20 mm²/s.
- With gas or steam, when $p_2 < \frac{p_1}{2}$, substitute "0.87 p_1 " in for the denominator $\sqrt{\Delta p (p_1 + p_2)}$ when making calculations.

● Cv: Capacity coefficient. Expresses valve flow rate at 60° F when pressure difference is 1 lbf/in², in US gal/min.

● Motor Operated Valve Specifications

Client		Destination		
UTE Order No.		Valve No.	Q'ty	
Class-Diameter	Class Diameter A	Valve type	Delivery date	
Valve spec.	Max. (Shut of) Pressure x Temp.	MPaG · °C		
	Inching	Yes (Times/Hour/1 Operation) · No		
	DSS	Yes · No		
	Liquid	Steam · Water · Drain · Heavy Oil · Others		
Valve Control Spec.	Standard	JEC · NEMA · Others		
	Maker	Nihon Gear · Seibu · Shimazu		
	Protection	Totally-enclosed outdoor use · Explosion-proof d G · Increased Safety eG		
	Handle switching	Automatic Return · Manual Return		
	Seating	(Open) Geared Torque / (Close) Geared Torque		
	Power	Motor	AC·DC V/3P · 1P/50HZ · 60HZ	
		Control	AC·DC V/3P · 1P/50HZ · 60HZ	
	Voltage Drop	Yes % · No		
	Insulating Class	E · B · F · H		
	Rated Time	15 min. (STD) · 30 min · 6.5 min. (DCSTD)		
	Limit Switch	2 trains · 4 trains · 6 trains · others		
	Field Position Indicator	100% (STD) · 3 positions · Others: /Japanese·English		
	Wire Through Hole	Motor	G	Pieces·Maker STD
		Control	G	Pieces·Maker STD
Calculation		G	Pieces·Maker STD	
Opening/Closing	Yes	min.	No	
Valve Control Option	Push Button	Yes (Open · Stop · Close) · No		
	Lamp	Yes (Colors: Open · Middle · Close) · No		
	Selsyn	Transmitter	Yes (Model · A C V) · No	
		Receiver	Yes (Model · Frame angle · Color) · No	
	Potentiometer	Transmitter	Yes (Model · Degree · Ω) · No	
		Receiver	Yes (Model · Frame angle · Color) · No	
		Regulator	Yes (Model) · No	
	Connector	Motor	Yes (Model · Wire dia. [□] · Cores · Dia.) · No	
		Control	Yes (Model · Wire dia. [□] · Cores · Dia.) · No	
		Calculation	Yes (Model · Wire dia. [□] · Cores · Dia.) · No	
	Explosion-proof · Increased Safety	Explosion-proof Grade	(Explosion-proof) d ₂ G ₄ · d ₂ G ₃ / (Increased Safety) eG ₃ · ed ₂ G ₃ only	
		Pressure-proof Packing	Motor	Cable Dia. [□] · Cores · Dia. · Screw G
			Control	Cable Dia. [□] · Cores · Dia. · Screw G
			Calculation	Cable Dia. [□] · Cores · Dia. · Screw G
Explosion-proof Grade		(Explosion-proof) d ₂ G ₄ · d ₂ G ₃ / (Increased Safety) eG ₃ · ed ₂ G ₃ only		
Pressure-proof Screw		Motor	Cable Dia. [□] · Cores · Dia. · Screw G	
	Control	Cable Dia. [□] · Cores · Dia. · Screw G		
	Calculation	Cable Dia. [□] · Cores · Dia. · Screw G		
Note 1: E and B types only for d ₂ G ₄ , H type only for d ₂ G ₃				
Note 2: eG ₃ shows the motor grade, ed ₂ G ₃ shows the actuator grade				
Remarks				

● Needle Valve Specifications

Client		Destination		
UTE Order No.		Valve No.	Q'ty	
Class-Diameter	Class Diameter A	Valve type	Delivery date	
Valve Name	Bypass · Flow Regulator · Pressure Regulator · Pressure Relief · External Blow · Filling Water · Continuous Blow · Drain · Recirculation · Other			
Valve Spec.	Design Pressure x Temp.	MPaG · °C		
	Valve Form	Globe Valve Needle · Angle Needle · Others		
	Needle Characteristic	Equal Percent (Quadric Curve) · Linear (Straight Line) · Others		
	Operation Mode	Pause · Start · Run · Trouble · Others		
Needle Spec.	Fluid*	Water · Steam (Super Heated · Saturated) · Drain (Water · Steam) · Oil · Gas · Others		
	Conditions	CASE I (MAX.)	CASE II (NOR.)	CASE III (MIN.)
	Flow Rate*	kg/H·m ³ /H·Nm ³ /H	kg/H·m ³ /H·Nm ³ /H	kg/H·m ³ /H·Nm ³ /H
	Primary Pressure*	MPaA	MPaA	MPaA
	Secondary Pressure*	MPaA	MPaA	MPaA
	Pressure Difference*	MPa	MPa	MPa
	Primary Temperature*	°C	°C	°C
	Specific Volume****	m ³ /kg	m ³ /kg	m ³ /kg
	Enthalpy****	KJ/kg	KJ/kg	KJ/kg
	Humidity****	%	%	%
	Specific Gravity***			mm ² /s
	Viscosity***	mm ² /s	mm ² /s	mm ² /s
	Molecular Weight**			
	Designated Position (%)			
Note: *... All, **... Gas, ***... Oil or Viscous Liquid, ****... Steam				
Remarks				

Clarify the pressure unit if you use a different unit from the one shown above.

Pressure-Temperature Ratings ASME B16.34-2004 Standard Class

● Applicable Materials: S25C, S28C, SF50A, SFVC2A, SCPH2, A105, A216WCB

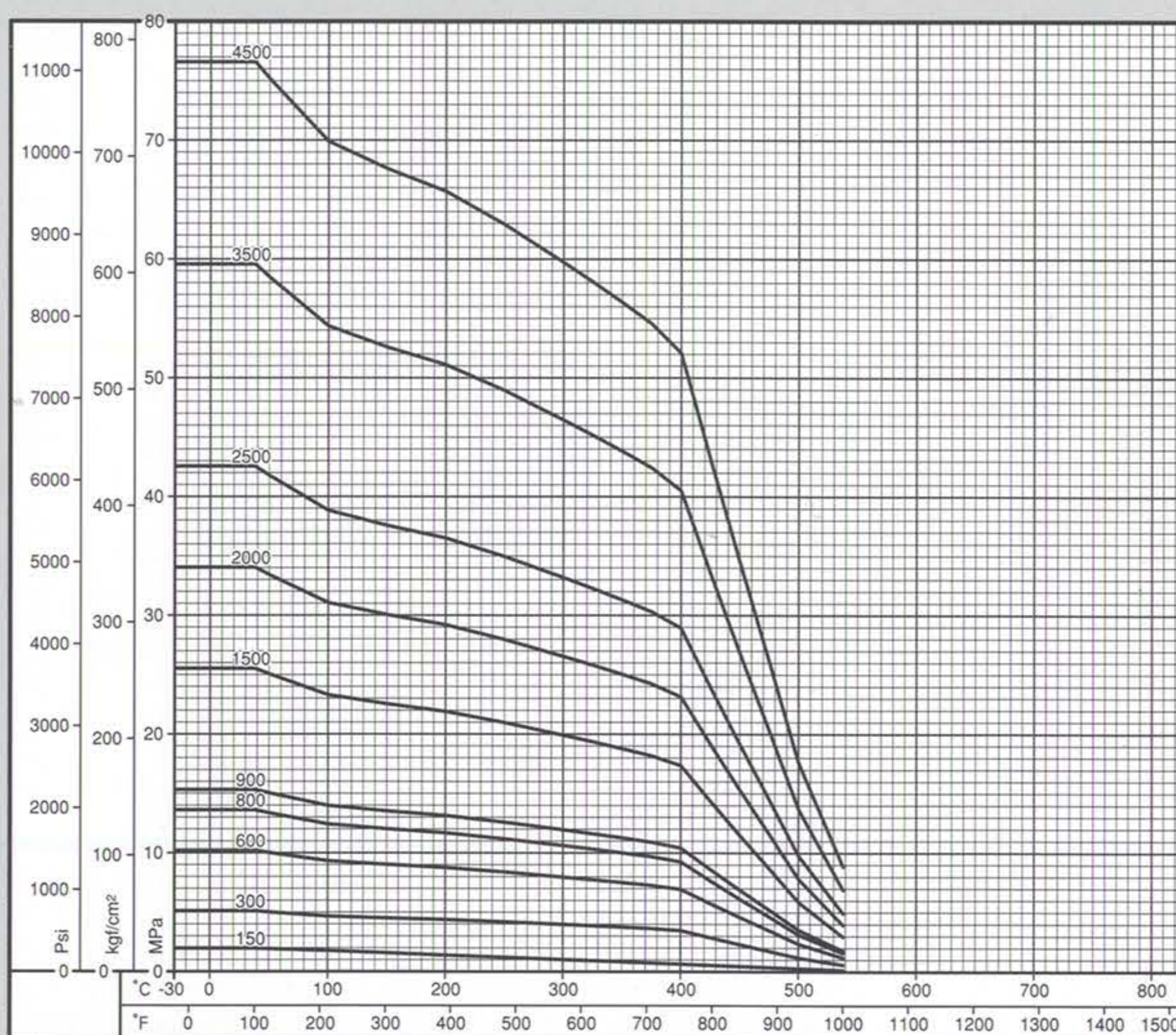

Temperature		Max. Working Pressure in MPa by Classes									
°F	°C	150	300	600	800	900	1500	2000	2500	3500	4500
-20~100	-29~38	1.96	5.11	10.21	13.61	15.32	25.53	34.04	42.55	59.57	76.59
122	50	1.92	5.01	10.02	13.36	15.04	25.06	33.41	41.77	58.48	75.19
212	100	1.77	4.66	9.32	12.42	13.98	23.30	31.06	38.83	54.36	69.90
302	150	1.58	4.51	9.02	12.02	13.52	22.54	30.05	37.56	52.58	67.61
392	200	1.38	4.38	8.76	11.68	13.14	21.90	29.20	36.50	51.10	65.70
482	250	1.21	4.19	8.39	11.18	12.58	20.97	27.96	34.95	48.93	62.91
572	300	1.02	3.98	7.96	10.62	11.95	19.91	26.54	33.18	46.45	59.73
617	325	0.93	3.87	7.74	10.32	11.61	19.36	25.81	32.26	45.16	58.07
662	350	0.84	3.76	7.51	10.01	11.27	18.78	25.04	31.30	43.82	56.35
707	375	0.74	3.64	7.27	9.69	10.91	18.18	24.24	30.31	42.43	54.55
752	400	0.65	3.47	6.94	9.26	10.42	17.36	23.14	28.93	40.50	52.08
797	425	0.55	2.88	5.75	7.67	8.63	14.38	19.17	23.97	33.56	43.15
842	450	0.46	2.30	4.60	6.13	6.90	11.50	15.33	19.17	26.84	34.51
887	475	0.37	1.74	3.49	4.65	5.23	8.72	11.62	14.53	20.34	26.15
932	500	0.28	1.18	2.35	3.13	3.53	5.88	7.83	9.79	13.71	17.63
1000	538	0.14	0.59	1.18	1.57	1.77	2.95	3.93	4.92	6.89	8.86
1022	550										
1067	575										
1112	600										
1157	625										
1202	650										
1247	675										
1292	700										
1337	725										
1382	750										
1427	775										
1472	800										
1500	816										

Note: Choose the pressure and temperature within the colored range.

●Applicable Materials: SFVAF11A, SCPH21, A182F11Cl.2, A217WC6

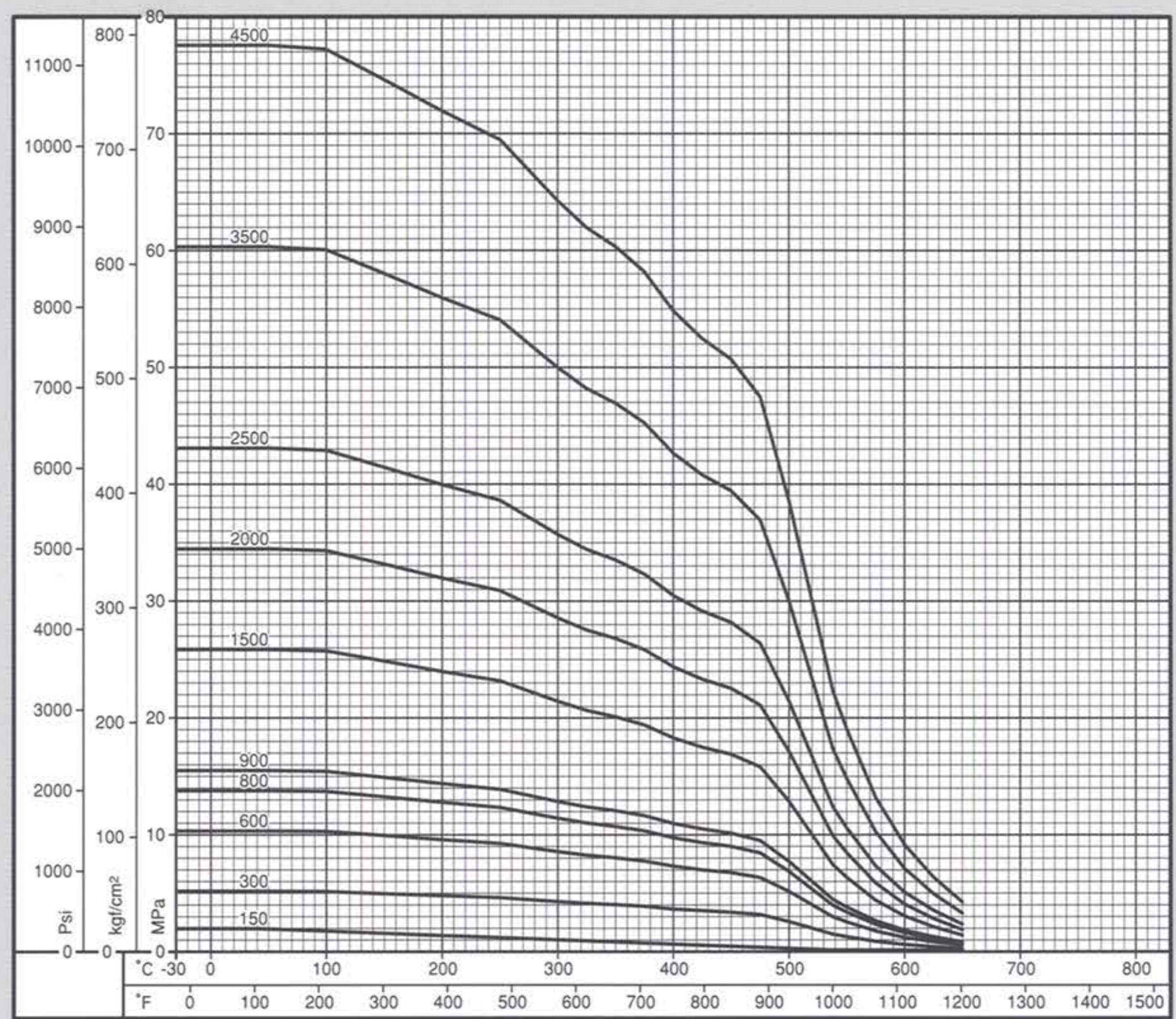

Temperature		Max. Working Pressure in MPa by Classes									
°F	°C	150	300	600	800	900	1500	2000	2500	3500	4500
-20~100	-29~38	1.98	5.17	10.34	13.78	15.51	25.86	34.47	43.09	60.33	77.57
122	50	1.95	5.17	10.34	13.78	15.51	25.86	34.47	43.09	60.33	77.57
212	100	1.77	5.15	10.30	13.72	15.44	25.74	34.32	42.90	60.06	77.22
302	150	1.58	4.97	9.95	13.26	14.92	24.87	33.16	41.45	58.03	74.62
392	200	1.38	4.80	9.59	12.79	14.39	23.98	31.97	39.96	55.95	71.94
482	250	1.21	4.63	9.27	12.35	13.90	23.18	30.90	38.62	54.05	69.48
572	300	1.02	4.29	8.57	11.43	12.86	21.44	28.57	35.71	49.98	64.26
617	325	0.93	4.14	8.26	11.02	12.40	20.66	27.54	34.43	48.19	61.96
662	350	0.84	4.03	8.04	10.72	12.07	20.11	26.82	33.53	46.93	60.33
707	375	0.74	3.89	7.76	10.35	11.65	19.41	25.86	32.32	45.25	58.18
752	400	0.65	3.65	7.33	9.76	10.98	18.31	24.40	30.49	42.67	54.85
797	425	0.55	3.52	7.00	9.34	10.51	17.51	23.33	29.16	40.81	52.47
842	450	0.46	3.37	6.77	9.01	10.14	16.90	22.54	28.18	39.44	50.70
887	475	0.37	3.17	6.34	8.45	9.51	15.82	21.10	26.39	36.93	47.48
932	500	0.28	2.57	5.15	6.86	7.72	12.86	17.14	21.44	30.01	38.59
1000	538	0.14	1.49	2.98	3.97	4.47	7.45	9.93	12.41	17.37	22.34
1022	550	☆ 0.14	1.27	2.54	3.38	3.81	6.35	8.46	10.59	14.82	19.06
1067	575	☆ 0.14	0.88	1.76	2.34	2.64	4.40	5.87	7.34	10.27	13.20
1112	600	☆ 0.14	0.61	1.22	1.62	1.83	3.05	4.07	5.09	7.12	9.16
1157	625	☆ 0.14	0.43	0.85	1.13	1.28	2.13	2.84	3.55	4.97	6.39
1202	650	☆ 0.11	0.28	0.57	0.75	0.85	1.42	1.89	2.36	3.30	4.26
1247	675										
1292	700										
1337	725										
1382	750										
1427	775										
1472	800										
1500	816										

Note: Choose the pressure and temperature within the colored range. Not available for flanged valves where marked with ☆.

Pressure-Temperature Rating

● Applicable Materials: SFVAF22B, SCPH32, A182F22Cl.3, A217WC9

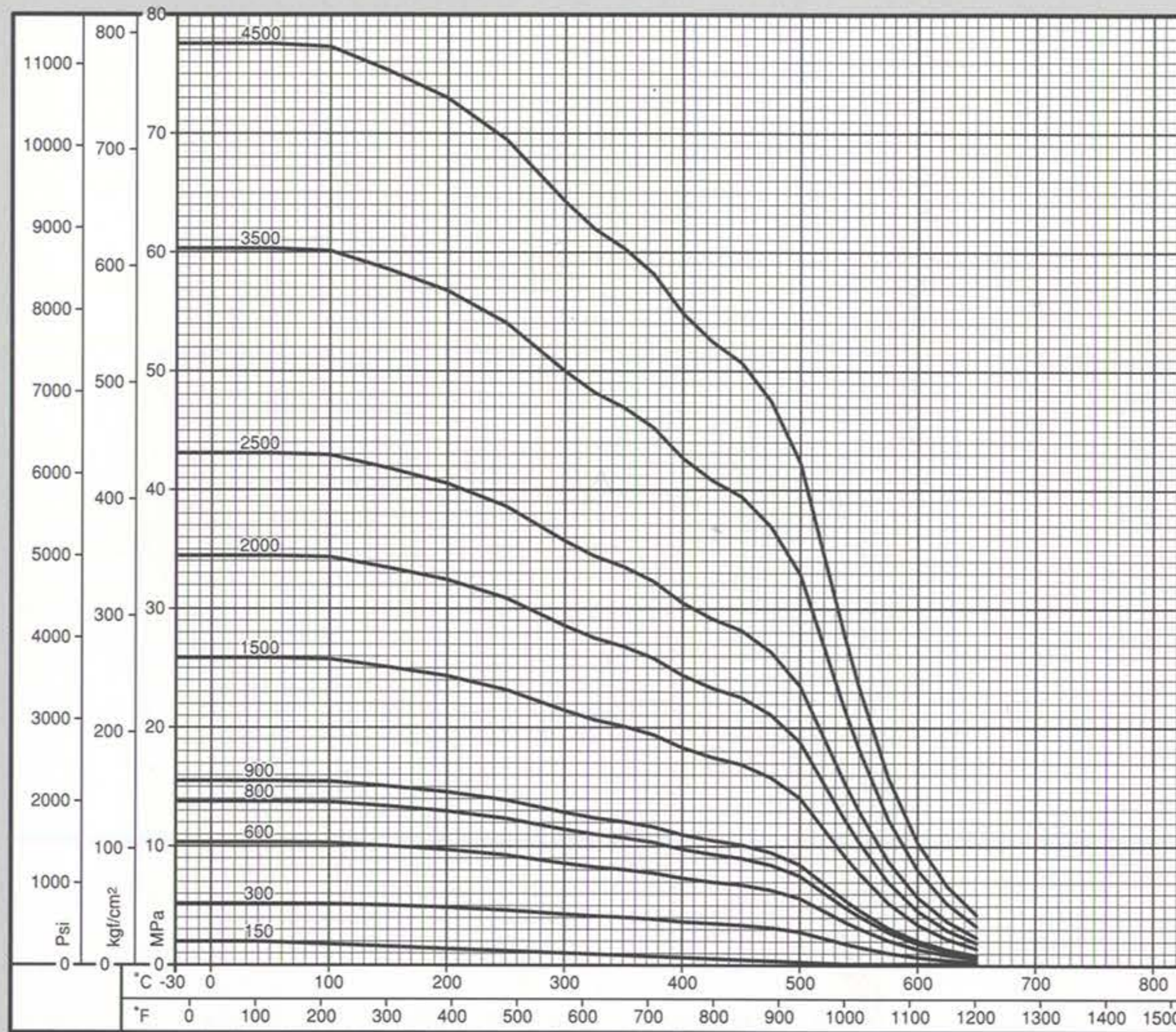

Temperature		Max. Working Pressure in MPa by Classes									
°F	°C	150	300	600	800	900	1500	2000	2500	3500	4500
-20~100	-29~38	1.98	5.17	10.34	13.78	15.51	25.86	34.47	43.09	60.33	77.57
122	50	1.95	5.17	10.34	13.78	15.51	25.86	34.47	43.09	60.33	77.57
212	100	1.77	5.15	10.30	13.74	15.46	25.76	34.35	42.94	60.12	77.30
302	150	1.58	5.03	10.03	13.38	15.06	25.08	33.45	41.82	58.55	75.28
392	200	1.38	4.86	9.72	12.96	14.58	24.34	32.44	40.54	56.76	72.98
482	250	1.21	4.63	9.27	12.35	13.90	23.18	30.90	38.62	54.05	69.48
572	300	1.02	4.29	8.57	11.43	12.86	21.44	28.57	35.71	49.98	64.26
617	325	0.93	4.14	8.26	11.02	12.40	20.66	27.54	34.43	48.19	61.96
662	350	0.84	4.03	8.04	10.72	12.07	20.11	26.82	33.53	46.93	60.33
707	375	0.74	3.89	7.76	10.35	11.65	19.41	25.86	32.32	45.25	58.18
752	400	0.65	3.65	7.33	9.76	10.98	18.31	24.40	30.49	42.67	54.85
797	425	0.55	3.52	7.00	9.34	10.51	17.51	23.33	29.16	40.81	52.47
842	450	0.46	3.37	6.77	9.01	10.14	16.90	22.54	28.18	39.44	50.70
887	475	0.37	3.17	6.34	8.45	9.51	15.82	21.10	26.39	36.93	47.48
932	500	0.28	2.82	5.65	7.53	8.47	14.09	18.79	23.50	32.90	42.30
1000	538	0.14	1.84	3.69	4.91	5.53	9.22	12.29	15.37	21.51	27.66
1022	550	☆ 0.14	1.56	3.13	4.17	4.69	7.82	10.42	13.03	18.23	23.45
1067	575	☆ 0.14	1.05	2.11	2.81	3.16	5.26	7.01	8.77	12.28	15.79
1112	600	☆ 0.14	0.69	1.38	1.84	2.07	3.44	4.59	5.74	8.03	10.33
1157	625	☆ 0.14	0.45	0.89	1.19	1.34	2.23	2.97	3.72	5.20	6.69
1202	650	☆ 0.11	0.28	0.57	0.75	0.85	1.42	1.89	2.36	3.30	4.26
1247	675										
1292	700										
1337	725										
1382	750										
1427	775										
1472	800										
1500	816										

Note: Choose the pressure and temperature within the colored range. Not available for flanged valves where marked with ☆.

● Applicable Materials: SUS304/F304, SCS13A/19A, A182F304, A351CF8/CF3

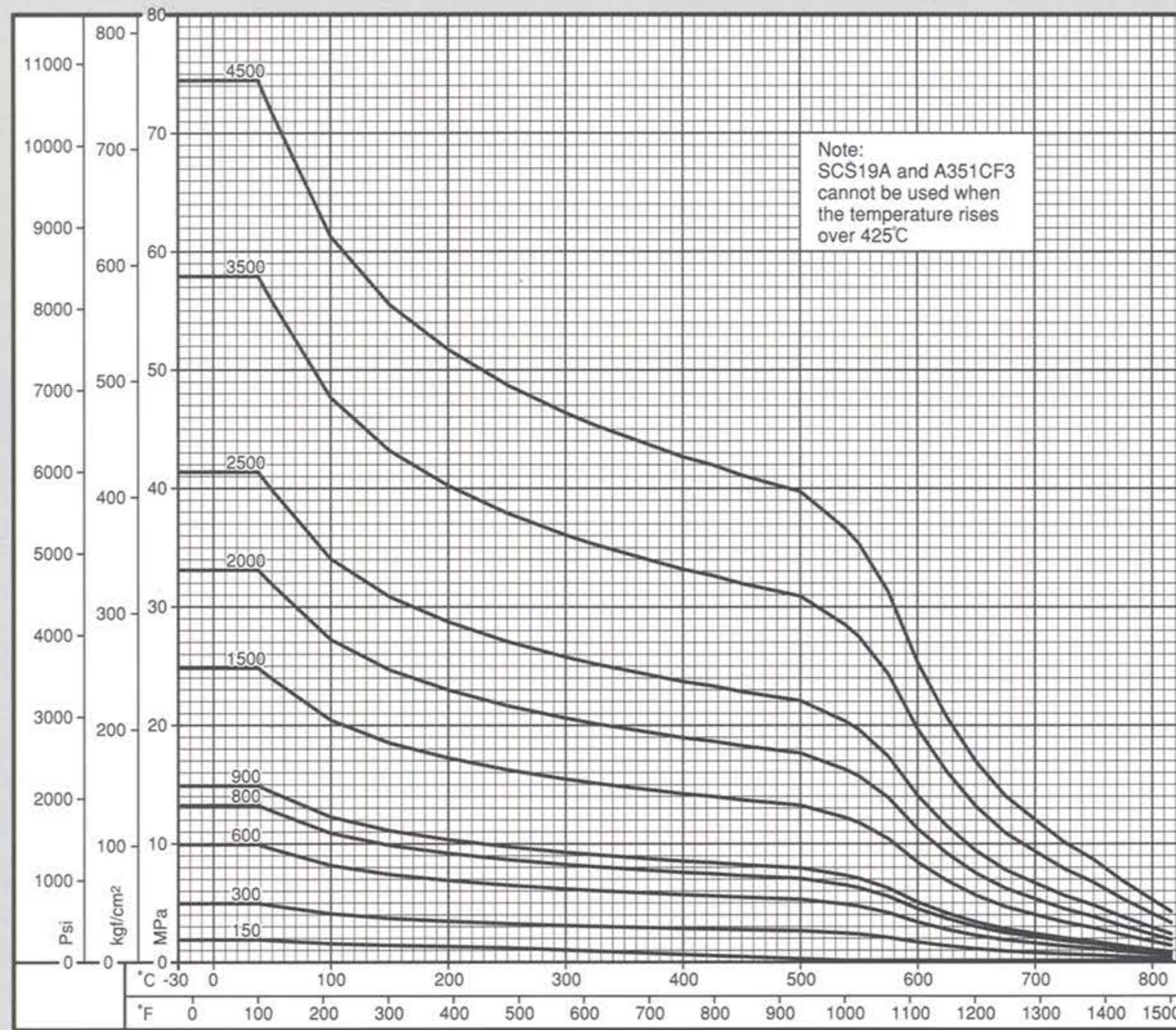

Temperature		Max. Working Pressure in MPa by Classes									
°F	°C	150	300	600	800	900	1500	2000	2500	3500	4500
-20~100	-29~38	1.90	4.96	9.93	13.23	14.89	24.82	33.09	41.37	57.91	74.46
122	50	1.83	4.78	9.56	12.75	14.35	23.91	31.88	39.85	55.79	71.73
212	100	1.57	4.09	8.17	10.89	12.26	20.43	27.23	34.04	47.66	61.28
302	150	1.42	3.70	7.40	9.86	11.10	18.50	24.67	30.84	43.17	55.51
392	200	1.32	3.45	6.90	9.19	10.34	17.24	22.98	28.73	40.22	51.72
482	250	1.21	3.25	6.50	8.66	9.75	16.24	21.65	27.07	37.90	48.73
572	300	1.02	3.09	6.18	8.24	9.27	15.46	20.61	25.76	36.06	46.37
617	325	0.93	3.02	6.04	8.06	9.07	15.11	20.14	25.19	35.26	45.33
662	350	0.84	2.96	5.93	7.90	8.89	14.81	19.75	24.69	34.56	44.44
707	375	0.74	2.90	5.81	7.74	8.71	14.52	19.35	24.19	33.86	43.55
752	400	0.65	2.84	5.69	7.58	8.53	14.22	18.96	23.70	33.18	42.66
797	425	0.55	2.80	5.60	7.46	8.40	14.00	18.66	23.33	32.65	41.99
842	450	0.46	2.74	5.48	7.30	8.22	13.70	18.27	22.84	31.97	41.11
887	475	0.37	2.69	5.39	7.18	8.08	13.47	17.96	22.45	31.42	40.40
932	500	0.28	2.65	5.30	7.06	7.95	13.24	17.65	22.07	30.90	39.73
1000	538	0.14	2.44	4.89	6.51	7.33	12.21	16.28	20.36	28.50	36.64
1022	550	☆ 0.14	2.36	4.71	6.28	7.07	11.78	15.70	19.63	27.48	35.34
1067	575	☆ 0.14	2.08	4.17	5.55	6.25	10.42	13.89	17.37	24.32	31.27
1112	600	☆ 0.14	1.69	3.38	4.50	5.06	8.44	11.25	14.07	19.69	25.32
1157	625	☆ 0.14	1.38	2.76	3.68	4.14	6.89	9.19	11.49	16.08	20.68
1202	650	☆ 0.14	1.13	2.25	3.00	3.38	5.63	7.50	9.38	13.13	16.89
1247	675	☆ 0.14	0.93	1.87	2.48	2.80	4.67	6.23	7.79	10.90	14.02
1292	700	☆ 0.14	0.80	1.61	2.14	2.41	4.01	5.35	6.69	9.36	12.04
1337	725	☆ 0.14	0.68	1.35	1.80	2.03	3.38	4.50	5.63	7.88	10.13
1382	750	☆ 0.14	0.58	1.16	1.54	1.73	2.89	3.84	4.81	6.74	8.67
1427	775	☆ 0.14	0.46	0.90	1.21	1.37	2.28	3.04	3.80	5.32	6.84
1472	800	☆ 0.12	0.35	0.70	0.93	1.05	1.74	2.33	2.92	4.09	5.26
1500	816	☆ 0.10	0.28	0.59	0.77	0.86	1.41	1.89	2.38	3.32	4.27

Note: Choose the pressure and temperature within the colored range. Not available for flanged valves where marked with ☆.

EXCO-F Series Quality Control

● EXCO-F Series valves quality control

EXCO-F Series valves are subjected to strict quality controls to assure that all parts have been properly assembled and that valves function satisfactory (leak-free smooth operating, etc.). Brief outlines of quality control are;

1. Material control

Chemical elements and mechanical properties of forged steel and bar materials shall strictly be inspected against supplier test data. Materials are then carefully selected based on requested conditions of use and labeled for comparison with the finished product.

2. Parts control

(1) Process control

All tools used in processing parts are subjected to controls in order to ensure preciseness. Finished products are closely examined for dimensional accuracy using specially designed gauges.

(2) Heat treatment control

Each part shall be heat-treated in accordance with specified hardness and process standards. Hardness is closely measured and kept under control.

3. Assembly control

Based on control items 1 and 2, we ensure all products coming off the line are of uniform precision and quality.

4. Finished product inspection

All finished products shall be checked closely part-by-part, and inspected for pressure and leak tests (valve seat) using the hydraulic pressure given on page 16. After the products passed the inspection, valve internal surfaces shall be dried and valve connection openings be sealed.

5. Air-tightness test

EXCO-F Series valves are recommended for vapor, water, oil, gas and air, however air-tightness tests are performed upon request. Clearly indicate how you intend to use the product when ordering. We will help you select the most suitable gland packing.

6. High pressure gas handling products

UTE is certified by the Ministry of International Trade and Industry to perform high pressure gas tests. Technical information is available upon request. When making inquiries, please provide us with the below information.

(1) User's name

(2) Class (1, 2, or 3)

(3) Types of fluid

(4) Pressure and temperature of fluid

Contact us for use in nuclear power generation, processing prohibited oil, etc.

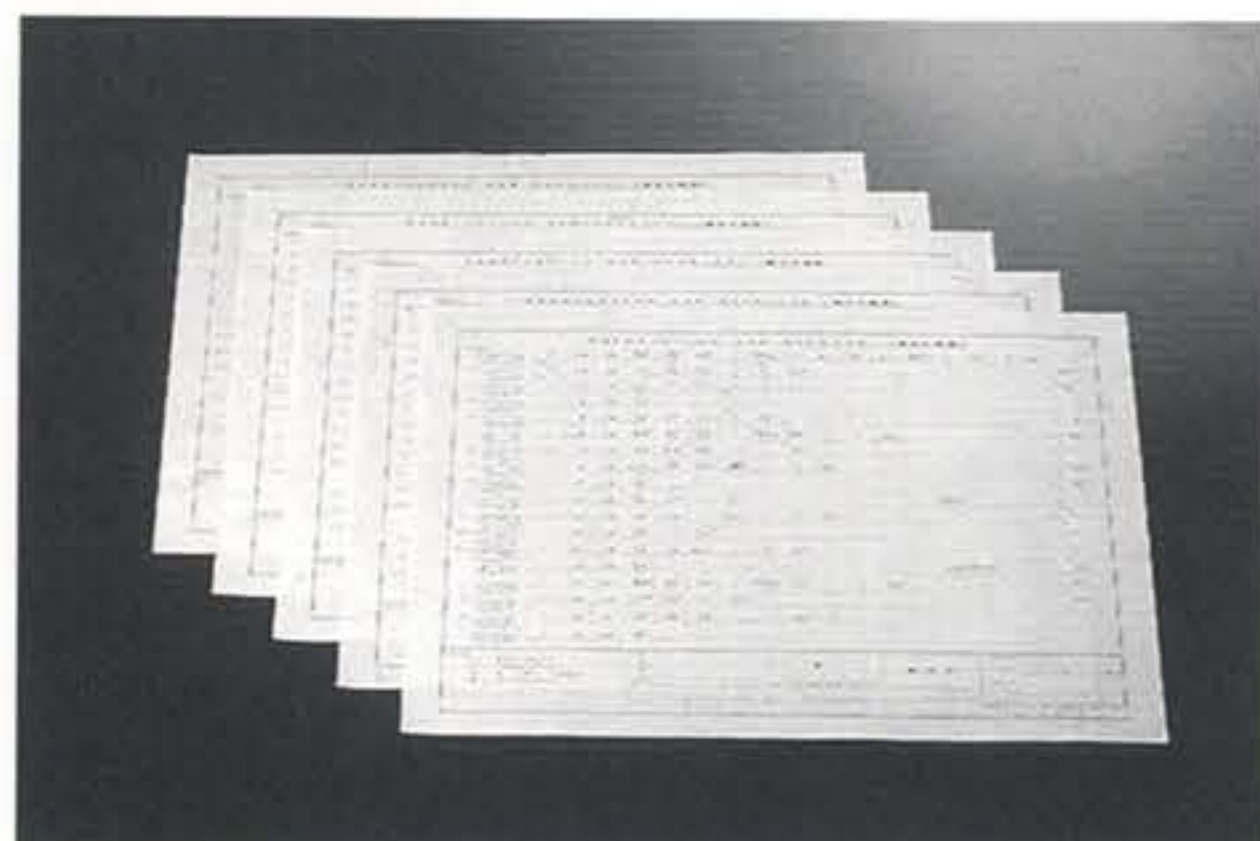

Fabrication sequence chart

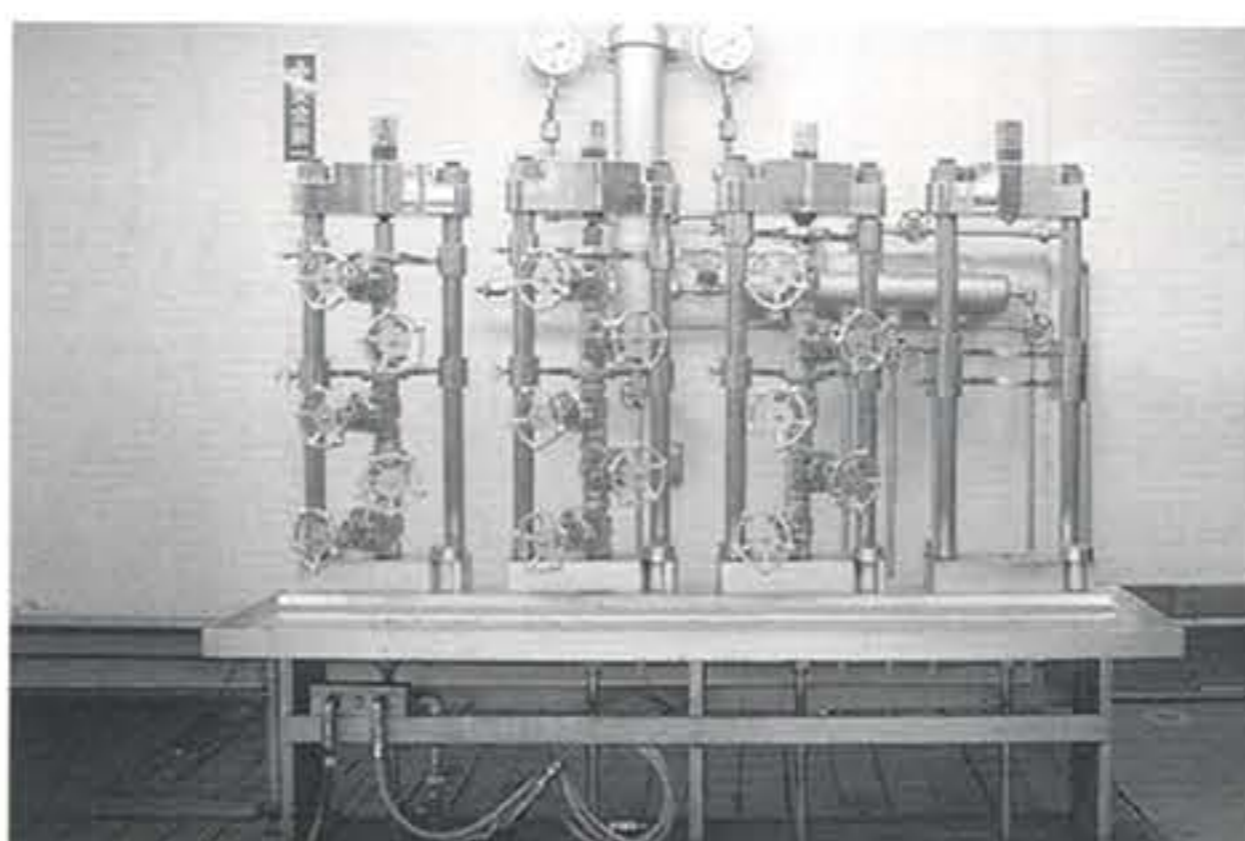

Hydraulic pressure test equipment



Helium leak detector

●Precautions in usage with EXCO-F Series valves

Observe the following 4 points in order to obtain the best lasting performance from valves.

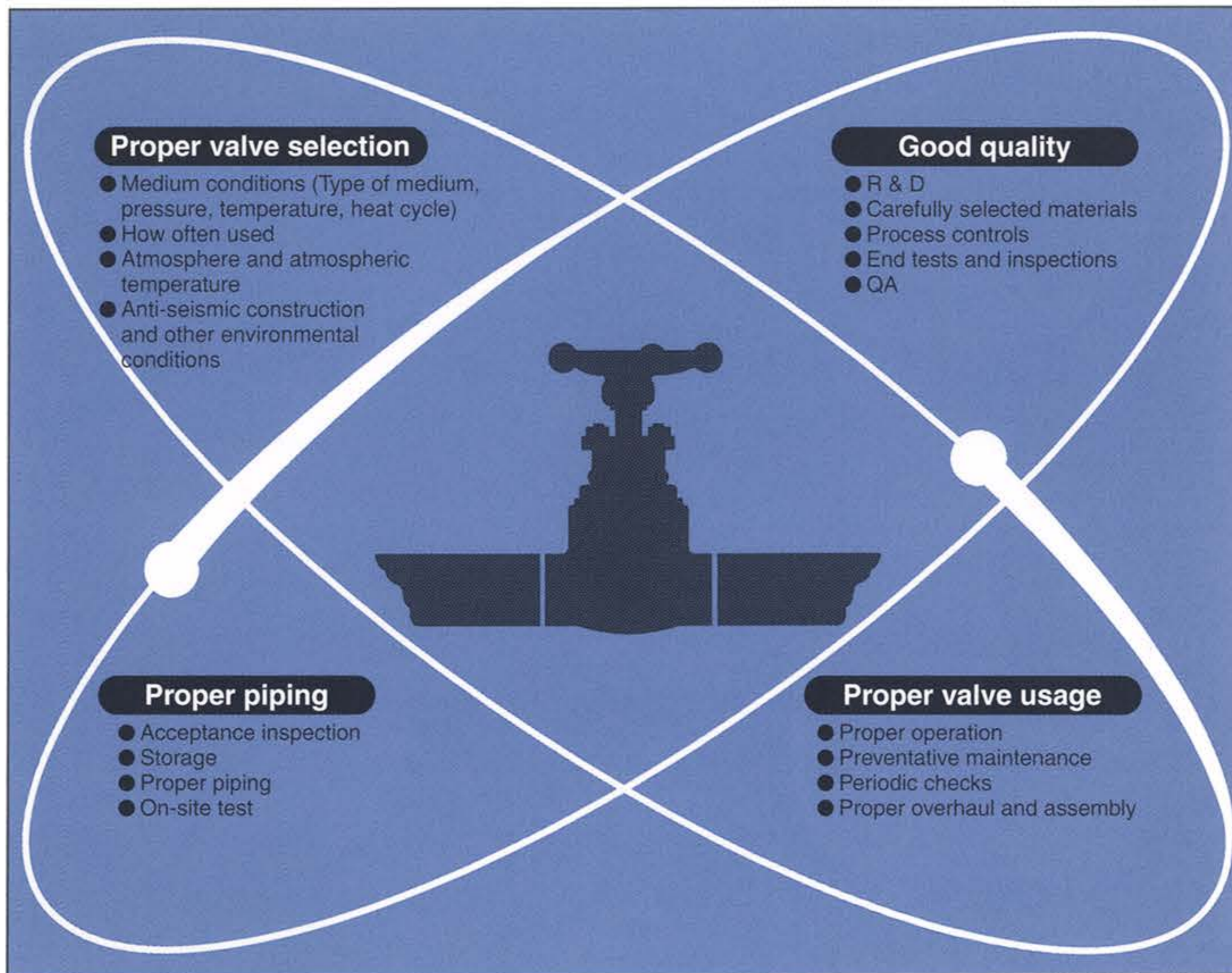

●Handling precautions for EXCO-F Series valves

Although all EXCO-F Series valves and parts are inspected prior to shipment, improper handling can impair performance. It is required to read these handling precautions in order to get the maximum performance. We recommend the product to be handled only by qualified personnel with ample knowledge of the product.

1. Storage

- (1) Keep polyethylene caps on valve ends while in storage. Infiltrated foreign matter can damage the seat and eventually cause leaking.
- (2) Do not store valves outdoors, in dusty places or in other adverse environment. Harsh environmental conditions can cause malfunctions or damage the seat.

- (3) Avoid leaving valves on the ground or concrete floors. Store on wood shelves in a dry place.

2. Care on installation

- (1) Check valve type, materials and size before connecting to pipes, and connect only when sure of having the proper parts.
- (2) With globe valves and check valves, check the flow direction arrow on the valve body before connecting to pipes. Also, keep lift check valves horizontal to prevent them from shutting by themselves under gravity.

3. Valve operation & maintenance

- (1) Turning the handwheel counter-clockwise opens the valve while clockwise shuts it. Levers and other helping means for turning the handwheel can impair valve functioning, and should be avoided.

- (2) Periodically grease the threaded part on valve stems.
- (3) Coat valves externally with a suitable rust-proofing if using the valve outdoors.
- (4) At the first time in using the valve, regulate surface pressure on packing by tightening the gland. Be careful to tighten the gland evenly.
- (5) If leaking is detected around the stem, evenly tighten the gland bolts to utilize the back seat to seal the leak. If the leak persists, change the packing. In such case, before disassemble check that the valve is internally depressurized.

EXCO-F Series Lineups

EXCO is a trademark of UTE, which coins an acronym formed of the words **EX**cellent and **CO**mpact. **EXCO-F** are great small **F**orged valves designed and built with sound technology. Over the years, we have provided customers all over the world with valves for every sort of use. EXCO-F valves, installed at many plants domestic and overseas, have certainly been in good order.

Some examples of the EXCO-F Series are shown here. Have a good look and let us know what you need.

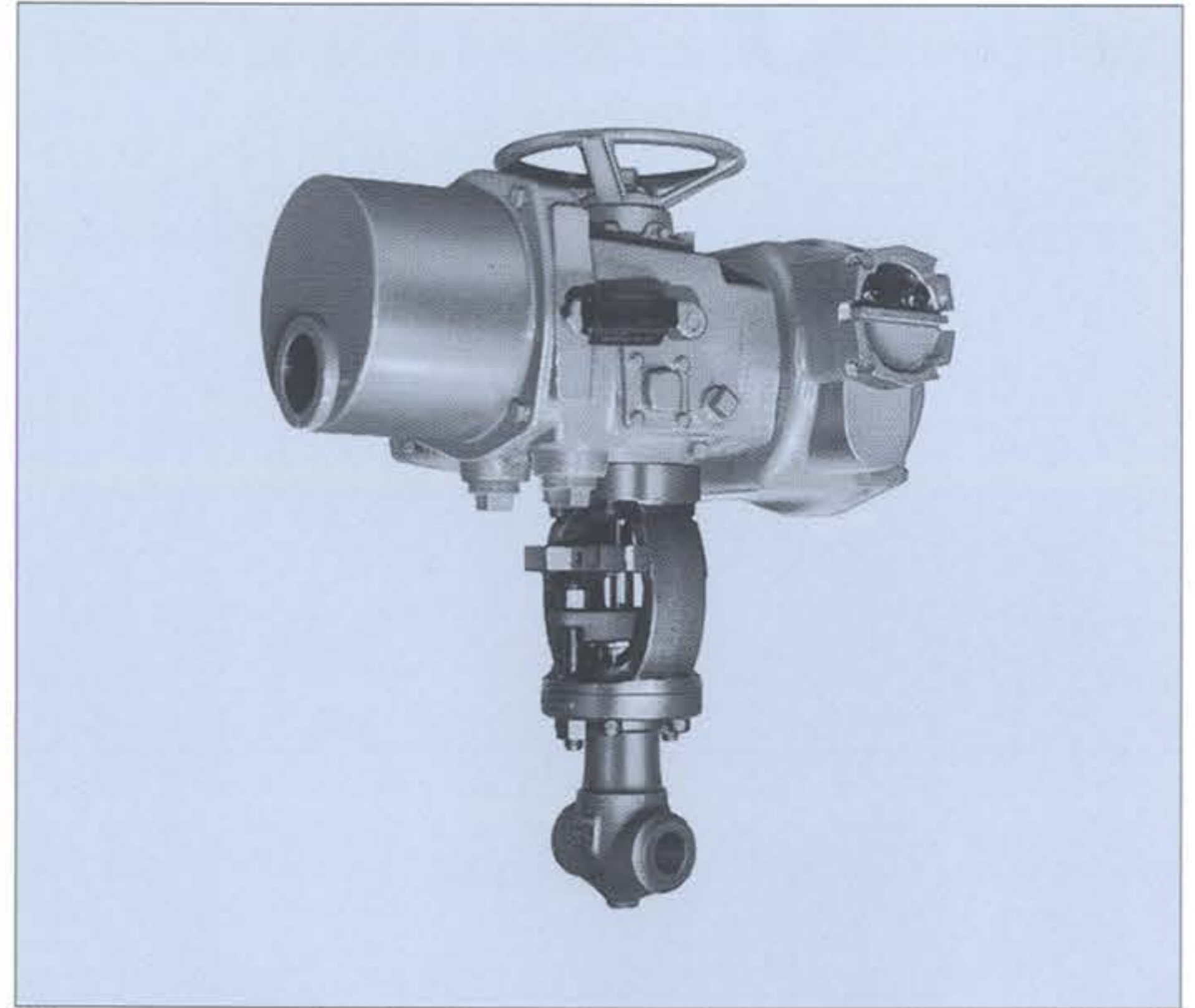

Motor operated valve



Globe valve with position indicator



High pressure lift check valve



With open/close limit switch



Bellows seal valve



Angle globe valve



High pressure angle needle valve

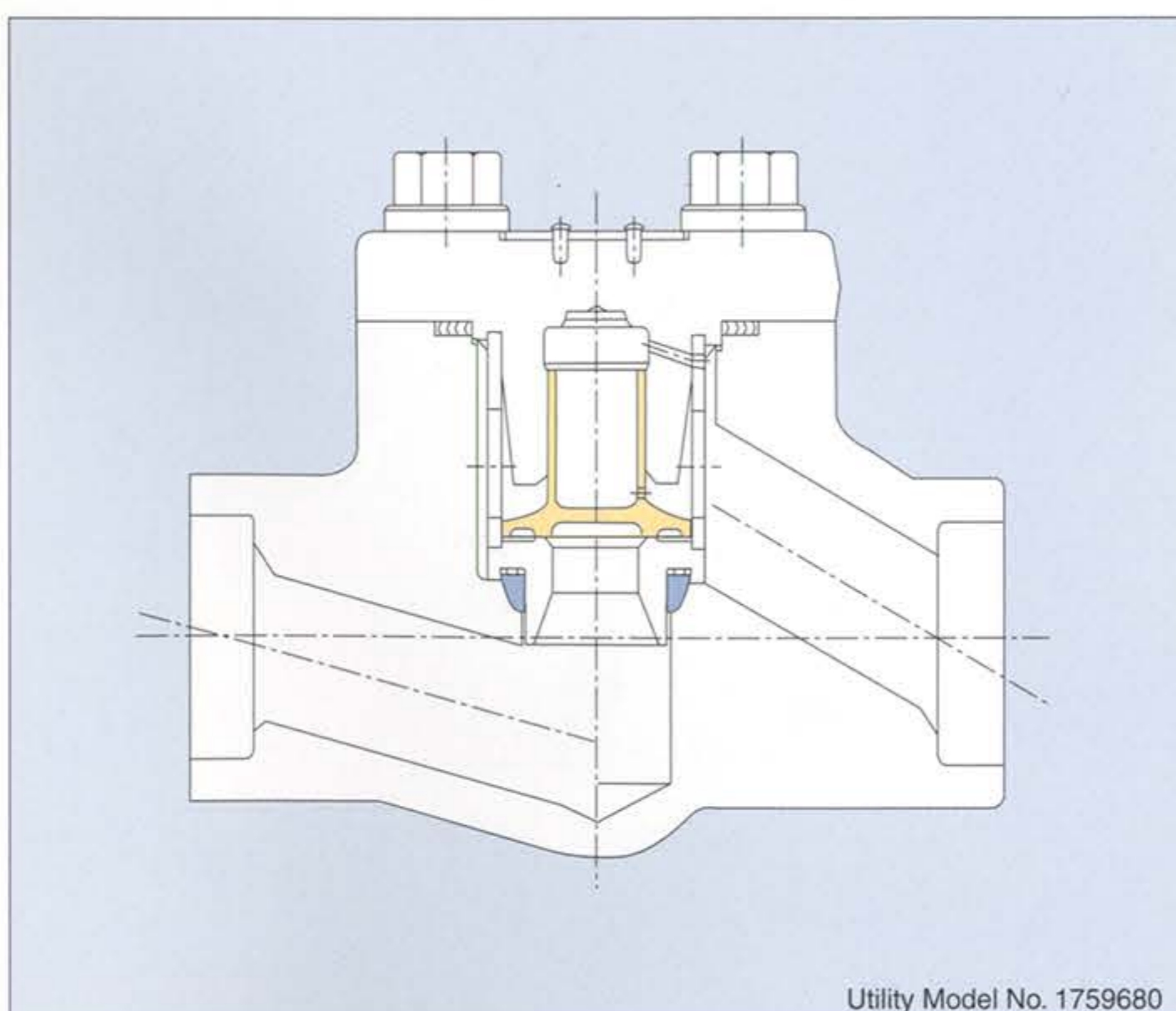

Low-flow rate lift check valve

Utility Model No. 1759680

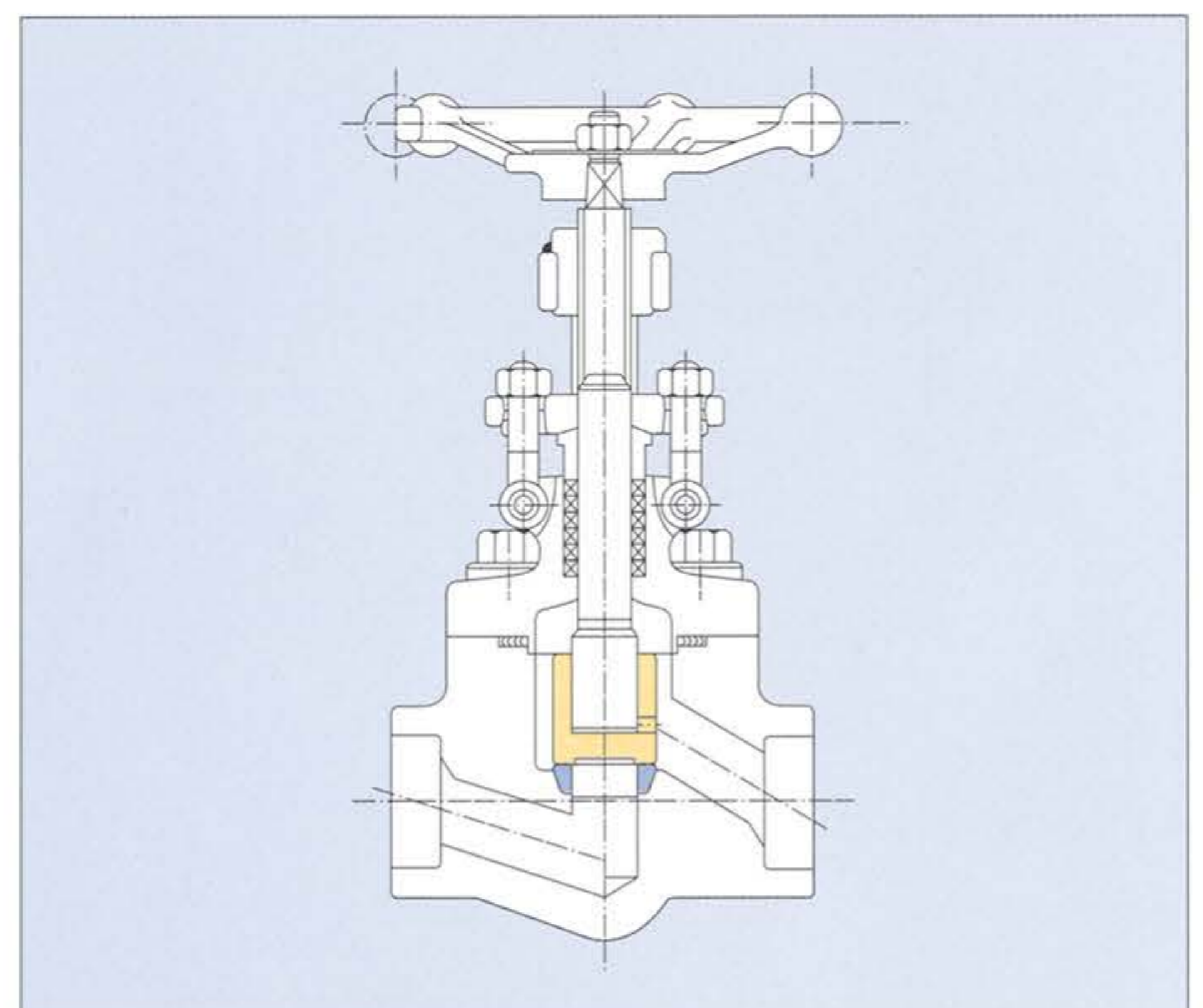

Screw down stop check valve

UTSUE VALVE CO., LTD.

Head Office & Plant: 2-1-13, Kitamura, Taisho-ku, Osaka 551-0032, Japan

Tel : 06-6552-3162 Fax: 06-6551-3245

URL : <http://www.utsue-valve.co.jp>

e-mail: ute2@sage.ocn.ne.jp (Sales Department)

e-mail: ute@maple.ocn.ne.jp (Engineering Department)

Office & Works : Tokyo / Hitachi / Takahama / Kashiwazaki-kariwa