

## Electric slides EGSK

**FESTO**

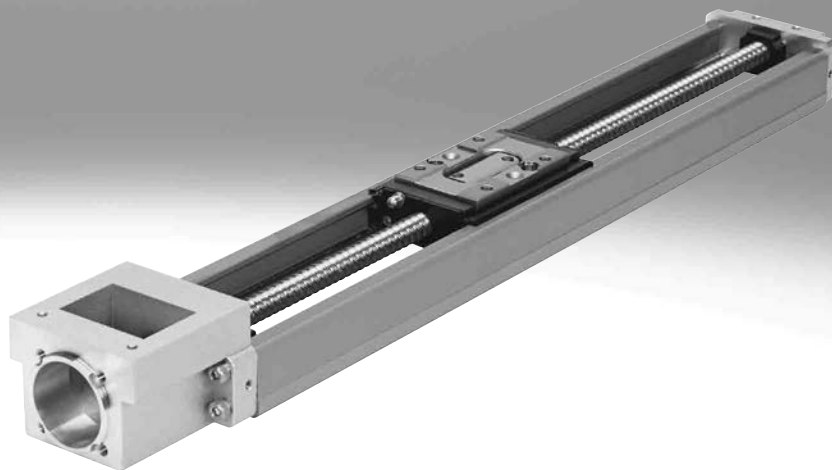

Selection aid

Overview of toothed belt and spindle axes

Toothed belt axes

- Speeds of up to 10 m/s
- Acceleration of up to 50 m/s<sup>2</sup>
- Repetition accuracy of up to ±0.08 mm
- Strokes of up to 8500 mm (longer strokes on request)
- Flexible motor mountings

Spindle axes

- Speeds of up to 2 m/s
- Acceleration of up to 20 m/s<sup>2</sup>
- Repetition accuracy of up to ±0.003 mm
- Strokes of up to 3000 mm

Coordinate system

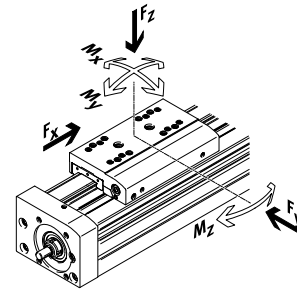

Toothed belt axes

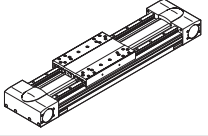
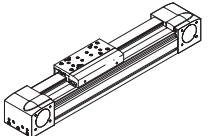
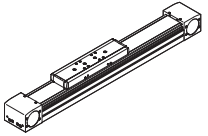
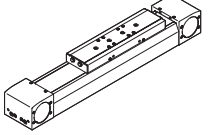
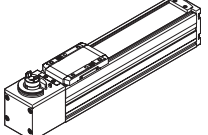
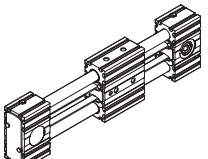
Type	F <sub>x</sub> [N]	v [m/s]	M <sub>x</sub> [Nm]	M <sub>y</sub> [Nm]	M <sub>z</sub> [Nm]	Characteristics
<b>Heavy-duty recirculating ball bearing guide</b>						
<b>EGC-HD-TB</b>						
	450 1000 1800	3 5 5	140 300 900	275 500 1450	275 500 1450	<ul style="list-style-type: none"> <li>• Flat drive unit with rigid, closed profile</li> <li>• Precision DUO guide rail with high load capacity</li> <li>• Ideal as a base axis for linear gantries and cantilever axes</li> </ul>
<b>Recirculating ball bearing guide</b>						
<b>EGC-TB-KF</b>						
	50 100 350 800 2500	3 5 5 5 5	3.5 16 36 144 529	10 132 228 680 1820	10 132 228 680 1820	<ul style="list-style-type: none"> <li>• Rigid, closed profile</li> <li>• Precision guide rail with high load capacity</li> <li>• Small drive pinions reduce required driving torque</li> <li>• Space-saving position sensing</li> </ul>
<b>ELGA-TB-KF</b>						
	350 800 1300 2000	5 5 5 5	16 36 104 167	132 228 680 1150	132 228 680 1150	<ul style="list-style-type: none"> <li>• Internal guide and toothed belt</li> <li>• Precision guide rail with high load capacity</li> <li>• Guide and toothed belt protected by cover strip</li> <li>• High feed forces</li> </ul>
<b>ELGA-TB-KF-F1</b>						
	260 600 1000	5 5 5	16 36 104	132 228 680	132 228 680	<ul style="list-style-type: none"> <li>• Suitable for use in the food zone</li> <li>• "Clean look": smooth, easy-to-clean surfaces</li> <li>• Internal guide and toothed belt</li> <li>• Precision guide rail with high load capacity</li> <li>• Guide and toothed belt protected by cover strip</li> </ul>
<b>ELGC-TB-KF</b>						
	75 120 250	1.2 1.5 1.5	5.5 29.1 59.8	4.7 31.8 56.2	4.7 31.8 56.2	<ul style="list-style-type: none"> <li>• Internal guide and toothed belt</li> <li>• Precision guide rail with high load capacity</li> <li>• Guide and toothed belt protected by cover strip</li> </ul>
<b>ELGR-TB</b>						
	50 100 350	3 3 3	2.5 5 15	20 40 124	20 40 124	<ul style="list-style-type: none"> <li>• Cost-optimised rod guide</li> <li>• Ready-to-install unit</li> <li>• Linear ball bearings with high load capacity for dynamic operation</li> </ul>

## Selection aid

## Overview of toothed belt and spindle axes

## Toothed belt axes

- Speeds of up to 10 m/s
- Acceleration of up to 50 m/s<sup>2</sup>
- Repetition accuracy of up to ±0.08 mm
- Strokes of up to 8500 mm (longer strokes on request)
- Flexible motor mountings

## Spindle axes

- Speeds of up to 2 m/s
- Acceleration of up to 20 m/s<sup>2</sup>
- Repetition accuracy of up to ±0.003 mm
- Strokes of up to 3000 mm

## Coordinate system

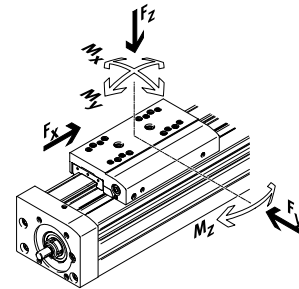

## Toothed belt axes

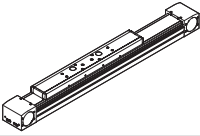
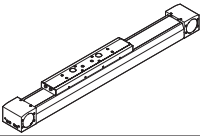
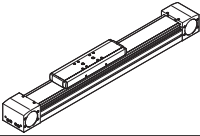
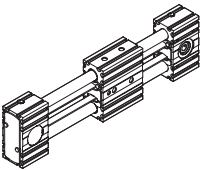
Type	$F_x$ [N]	$v$ [m/s]	$M_x$ [Nm]	$M_y$ [Nm]	$M_z$ [Nm]	Characteristics
<b>Roller bearing guide</b>						
<b>ELGA-TB-RF</b>						
	350 800 1300	10 10 10	11 30 100	40 180 640	40 180 640	<ul style="list-style-type: none"> <li>• Heavy-duty roller bearing guide</li> <li>• Guide and toothed belt protected by cover strip</li> <li>• Speeds of up to 10 m/s</li> <li>• Lower weight than axes with guide rails</li> </ul>
<b>ELGA-TB-RF-F1</b>						
	260 600 1000	10 10 10	8.8 24 80	32 144 512	32 144 512	<ul style="list-style-type: none"> <li>• Suitable for use in the food zone</li> <li>• "Clean look": smooth, easy-to-clean surfaces</li> <li>• Heavy-duty roller bearing guide</li> <li>• Guide and toothed belt protected by cover strip</li> <li>• Lower weight than axes with guide rails</li> </ul>
<b>Plain-bearing guide</b>						
<b>ELGA-TB-G</b>						
	350 800 1300	5 5 5	5 10 120	30 60 120	10 20 40	<ul style="list-style-type: none"> <li>• Guide and toothed belt protected by cover strip</li> <li>• For simple handling tasks</li> <li>• As a drive component for external guides</li> <li>• Insensitive to harsh ambient conditions</li> </ul>
<b>ELGR-TB-GF</b>						
	50 100 350	1 1 1	1 2.5 1	10 20 40	10 20 40	<ul style="list-style-type: none"> <li>• Cost-optimised rod guide</li> <li>• Ready-to-install unit</li> <li>• Heavy-duty plain bearings for use in harsh ambient conditions</li> </ul>

## Selection aid

### Overview of toothed belt and spindle axes

#### Toothed belt axes

- Speeds of up to 10 m/s
- Acceleration of up to 50 m/s<sup>2</sup>
- Repetition accuracy of up to ±0.08 mm
- Strokes of up to 8500 mm (longer strokes on request)
- Flexible motor mountings

#### Spindle axes

- Speeds of up to 2 m/s
- Acceleration of up to 20 m/s<sup>2</sup>
- Repetition accuracy of up to ±0.003 mm
- Strokes of up to 3000 mm

#### Coordinate system

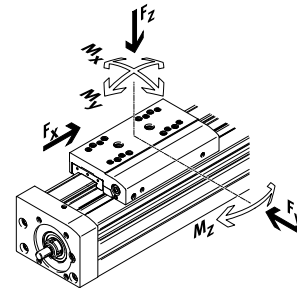

#### Spindle axes

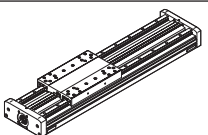
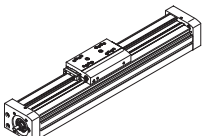
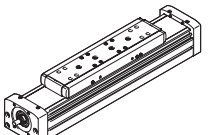
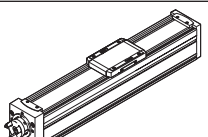
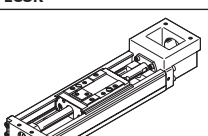
Type	F <sub>x</sub> [N]	v [m/s]	M <sub>x</sub> [Nm]	M <sub>y</sub> [Nm]	M <sub>z</sub> [Nm]	Characteristics
<b>Heavy-duty recirculating ball bearing guide</b>						
<b>EGC-HD-BS</b>						
	400 650 1500	0.5 1.0 1.5	140 300 900	275 500 1450	275 500 1450	<ul style="list-style-type: none"> <li>• Flat drive unit with rigid, closed profile</li> <li>• Precision DUO guide rail with high load capacity</li> <li>• Ideal as a base axis for linear gantries and cantilever axes</li> </ul>
<b>Recirculating ball bearing guide</b>						
<b>EGC-BS-KF</b>						
	400 650 1500 3000	0.5 1.0 1.5 2.0	16 36 144 529	132 228 680 1820	132 228 680 1820	<ul style="list-style-type: none"> <li>• Rigid, closed profile</li> <li>• Precision guide rail with high load capacity</li> <li>• For the highest requirements in terms of feed force and accuracy</li> <li>• Space-saving position sensing</li> </ul>
<b>ELGA-BS-KF</b>						
	650 1600 3400 6400	0.5 1.0 1.5 2.0	16 36 104 167	132 228 680 1150	132 228 680 1150	<ul style="list-style-type: none"> <li>• Internal guide and ball screw</li> <li>• Precision guide rail with high load capacity</li> <li>• For the highest requirements in terms of feed force and accuracy</li> <li>• Guide and ball screw protected by cover strip</li> <li>• Space-saving position sensing</li> </ul>
<b>ELGC-BS-KF</b>						
	40 100 200 350	0.6 0.6 0.8 1.0	1.3 5.5 29.1 59.8	1.1 4.7 31.8 56.2	1.1 4.7 31.8 56.2	<ul style="list-style-type: none"> <li>• Internal guide and ball screw</li> <li>• Guide and ball screw protected by cover strip</li> <li>• Space-saving position sensing</li> </ul>
<b>EGSK</b>						
	57 133 184 239 392	0.33 1.10 0.83 1.10 1.48	13 28.7 60 79.5 231	3.7 9.2 20.4 26 77.3	3.7 9.2 20.4 26 77.3	<ul style="list-style-type: none"> <li>• Spindle axes with maximum precision, compactness and rigidity</li> <li>• Recirculating ball bearing guide and ball screw without caged ball bearings</li> <li>• Standard designs in stock</li> </ul>

## Key features

### At a glance

- The electric slide EGSK stands out because of its precision, repetition accuracy, compact design and rigidity.
- The U-shaped steel housing serves simultaneously as a guide rail. The slide combines linear guide elements and the spindle nut of the ball screw in one component, thus avoiding an accumulation of manufacturing tolerances.
- Recirculating ball bearing guide and ball screw
- Three accuracy classes
- Optionally available with additional slide
- Sizes 33 and 46 also available in a short slide design
- Standard designs available ex-stock

### Characteristic values of the axes

The specifications shown in the table are maximum values.

The precise values for each of the variants can be found in the relevant data sheet in the catalogue.

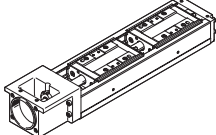
Design	Size	Working stroke [mm]	Velocity [m/s]	Repetition accuracy [μm]	Feed force [N]	Guide characteristics				
						Forces and torques				
						Fy [N]	Fz [N]	Mx [Nm]	My [Nm]	Mz [Nm]
<b>Electric slides EGSK</b>						→ Page 8				
	15	25 ... 100	0.33	±3	57	1185	1185	13	3.7	3.7
	20	25 ... 125	1.10	±3	133	2204	2204	28.7	9.2	9.2
	26	50 ... 200	0.83	±3	184	3528	3528	60	20.4	20.4
	33	100 ... 630	1.10	±3	239	3920	3920	79.5	26	26
	46	200 ... 840	1.48	±3	392	7809	7809	231	77.3	77.3

### Complete system comprising electric slide, motor, motor controller and motor mounting kit

Motor

Motor controller

→ Page 24



Motor mounting kit

→ Page 24

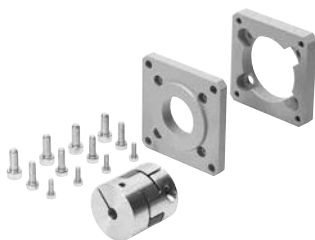

Kit comprising:

- Motor flange
- Coupling
- Screws

 **Note**

A range of specially matched complete solutions is available for the electric slide EGSK and the motors.

Peripherals overview

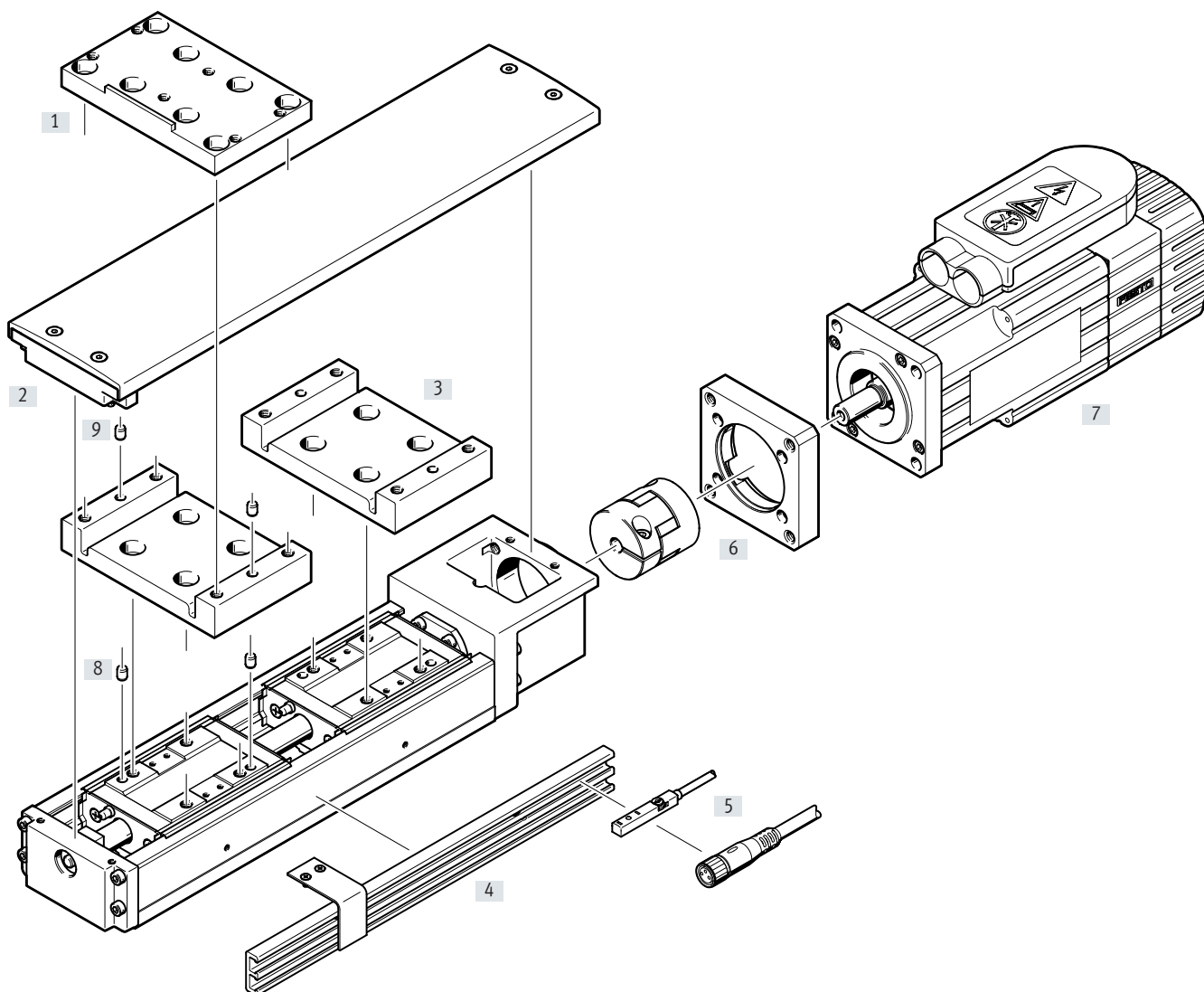

## Peripherals overview

Accessories			
	Type	Description	→ Page/Internet
[1]	Cross connecting kit EHAM-S1	For mounting an assembly axis EGSK at right angles on the slide of a basic axis EGSK. The assembly axis is one size smaller than the basic axis.	27
[2]	Covering kit EASC-S1	For covering the axis profile that is open at the top. The kit includes a slide adapter EASAS1	29
[3]	Slide adapter EASAS1	Required to mount the payload in combination with the covering kit for axis variants with additional slide	28
[4]	Sensor rail EAPRS1-S	<ul style="list-style-type: none"> <li>For mounting the inductive proximity switch SIES-8M on the electric slide</li> <li>Switch lugs are included in the scope of delivery</li> </ul>	31
[5]	Proximity switch SIES-8M	Inductive proximity switch, for T-slot	32
[6]	Axial kit EAMM	For axial motor mounting (comprises: coupling and motor flange)	24
[7]	Motor EMME, EMMS	Motors specially matched to the axis, with or without brake	24
[8]	Centring pin ZBS	For centring loads and attachments on the slide	32
[9]	Centring pin ZBS	For centring loads and attachments on the slide adapter	32

## Type codes

001	Series
EGSK	Electric slide

002	Size
15	15
20	20
26	26
33	33
46	46

003	Stroke
25	25
50	50
75	75
100	100
125	125
150	150
200	200
300	300
400	400
500	500
600	600
800	800

004	Spindle pitch
1P	1 mm
2P	2 mm
6P	6 mm
10P	10 mm
20P	20 mm

005	Accuracy
	Standard
H	H class
P	P class

006	Slide design
	Standard
S	Slide, short



007	Additional slide
	None
Z	Additional slide

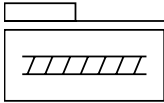

## Data sheet

Function



-  - Size  
15 ... 46
-  - Stroke length  
25 ... 840 mm

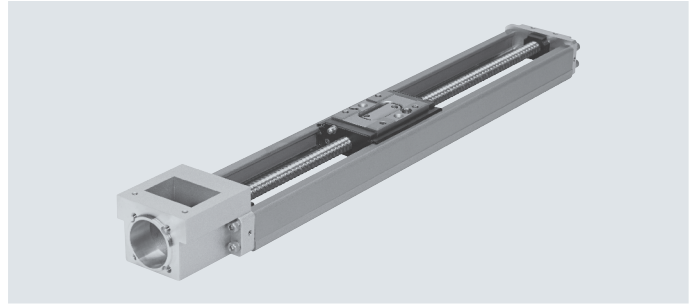

General technical data														
Size			15 <sup>2)</sup>			20		26		33		46		
Spindle pitch			1	2	1	6	2	6	6	10	10	20		
			Code <sup>1)</sup>											
Design			Electromechanical linear axis with ball screw											
Guide			Recirculating ball bearing guide											
Mounting position			Any											
Type of mounting for payload			Female thread											
			Centring sleeve					Dowel pin						
Working stroke <sup>3)</sup>	-	[mm]	25 ... 100			25 ... 125		50 ... 200		100 ... 600		200 ... 800		
	S	[mm]	-			-		-		130 ... 630		240 ... 840		
Max. feed force	-/H <sup>4)</sup>	[N]	36	19	69	72	116	116	150	148	264	192		
F <sub>x,max</sub>	P <sup>5)</sup>	[N]	57	31	110	133	184	184	239	183	392	343		
Max. driving torque	-/H <sup>4)</sup>	[Ncm]	0.6	0.6	1.1	6.9	3.7	11	14	24	42	61		
M <sub>driving,max</sub>	P <sup>5)</sup>	[Ncm]	0.9	1.0	1.8	13	5.9	18	23	29	62	109		
No-load torque	-/H	[Ncm]	0.4	0.4	0.5	0.5	1.5	1.5	7	7	10	10		
M <sub>no-load</sub>	P	[Ncm]	0.8	0.8	1.2	1.2	4.0	4.0	15	15	17	17		
Max. rotational speed <sup>6)</sup>		[rpm]	9600	9900	11400	7900	8400	5900	4700	4700	3100	3100		
Max. speed <sup>6)</sup>	-/H	[m/s]	0.16	0.33	0.19	0.79	0.28	0.59	0.47	0.79	0.52	1.05		
	P	[m/s]	0.16	0.33	0.19	1.10	0.28	0.83	0.66	1.10	0.74	1.48		
Max. acceleration		[m/s <sup>2</sup> ]	10			10		10		20		20		
Homing			Inductive proximity switch SIES-8M											

- 1) Variant code → page 8
- 2) Size 15 is only available in the accuracy classes H and P
- 3) Maximum travel distance → page 17  
In combination with an additional slide, the working stroke is reduced by the length of the additional slide and the distance between the two slides.
- 4) Loads are based on a specified service life of  $5 \times 10^8$  revolutions
- 5) Loads are based on a specified service life of  $1.25 \times 10^8$  revolutions
- 6) Reduced speeds with sizes 33 and 46 with long strokes → page 11

## Operating and environmental conditions

Ambient temperature	[°C]	0 ... +40
Relative humidity	[%]	0 ... 95 (non-condensing)

## Weight [kg]

Size			15			20		26		33		46	
			Code <sup>1)</sup>										
Basic weight with 0 mm stroke <sup>2)</sup>	-		0.16	0.38	0.78	1.38	5.17						
	S		-	-	-	1.28	4.77						
Additional weight per 100 mm stroke	-		0.12	0.27	0.42	0.63	1.27						
Moving mass	-		0.04	0.07	0.15	0.31	0.91						
	S		-	-	-	0.17	0.57						
Additional slide Z	-		0.04	0.07	0.15	0.31	0.91						
	S		-	-	-	0.17	0.57						

- 1) Variant code → page 8
- 2) Incl. slide, without additional slide

Data sheet

Accuracy data [µm]			15		20		26		33		46	
Size	Stroke	Code <sup>1)</sup>										
Repetition accuracy <sup>2)</sup>		–	–		±10		±10		±10		±10	
		H	±4		±5		±5		±5		±5	
		P	±3		±3		±3		±3		±3	
Running parallelism	25 ... 340	H	20		25		25		25		35	
	400 ... 540	H	–		–		–		35		35	
	600 ... 640	H	–		–		–		40		40	
	800 ... 840	H	–		–		–		–		50	
	25 ... 340	P	10		10		10		10		15	
	400 ... 540	P	–		–		–		15		15	
	600 ... 640	P	–		–		–		20		20	
Max. reversing backlash		–	–		20		20		20		20	
		H	10		10		10		20		20	
		P	2		3		3		3		3	

1) Variant code → page 8

2) The repetition accuracy that can be achieved with a motor/axis system is also influenced by the angular resolution of the motor and the chosen control parameters. The specified repetition accuracy cannot, therefore, be achieved with all motors

Materials

Sectional view

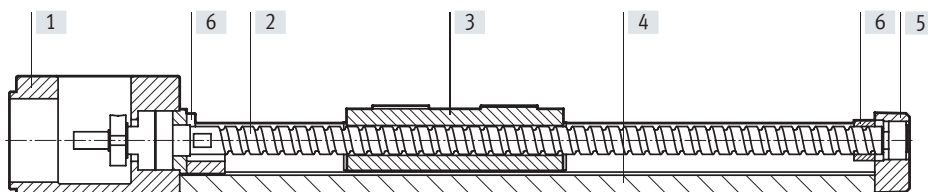

Electric slide

[1] Drive cover	Coated die-cast aluminium
[2] Spindle	Steel
[3] Slide	Steel
[4] Profile	High-alloy steel
[5] End cap	Coated die-cast aluminium
[6] Buffer	Ethylene vinyl acetate copolymer
Note on materials	RoHS-compliant
	Contains paint-wetting impairment substances

Mass moment of inertia

Size		15		20		26		33		46	
Spindle pitch		1	2	1	6	2	6	6	10	10	20
	Code <sup>1)</sup>										
J <sub>0</sub>	[kg mm <sup>2</sup> ]	0.030	0.033	0.087	0.144	0.357	0.481	1.15	1.66	8.47	15.4
	S [kg mm <sup>2</sup> ]	–	–	–	–	–	–	0.795	1.07	6.04	10.4
J <sub>H</sub> per 100 mm stroke	[kg mm <sup>2</sup> /100 mm]	0.048		0.100		0.316		0.771		3.902	
J <sub>L</sub> per kg payload	[kg mm <sup>2</sup> /kg]	0.03	0.10	0.03	0.91	0.10	0.91	0.91	2.53	2.53	10.13
J <sub>W</sub> per additional slide	[kg mm <sup>2</sup> ]	0.001	0.004	0.002	0.058	0.016	0.14	0.28	0.79	2.31	9.22
	S [kg mm <sup>2</sup> ]	–	–	–	–	–	–	0.16	0.43	1.44	5.78

1) Variant code → page 8

The mass moment of inertia J<sub>A</sub> of the entire axis is calculated as follows:

$$J_A = J_0 + J_W + J_H \times \text{working stroke} + J_L \times m_{\text{payload}}$$

Data sheet

Velocity v, rotational speed n as a function of working stroke l

EGSK-33-...-6P

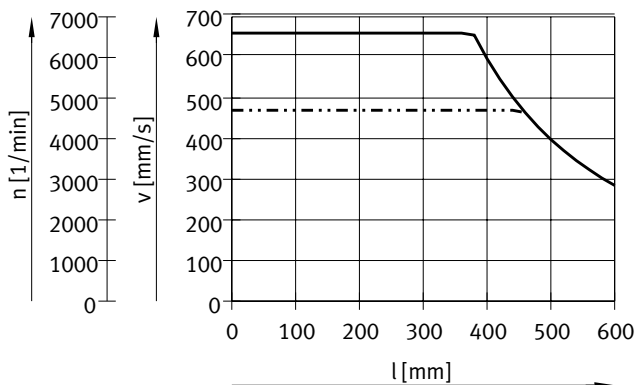

— EGSK-33- ... -6P-P  
 - - - - EGSK-33- ... -6P, EGSK-33- ... -6P-H

EGSK-33-...-10P

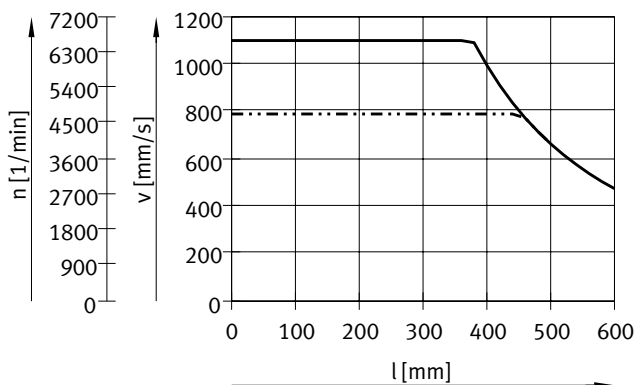

— EGSK-33- ... -10P-P  
 - - - - EGSK-33- ... -10P, EGSK-33- ... -10P-H

EGSK-46-...-10P

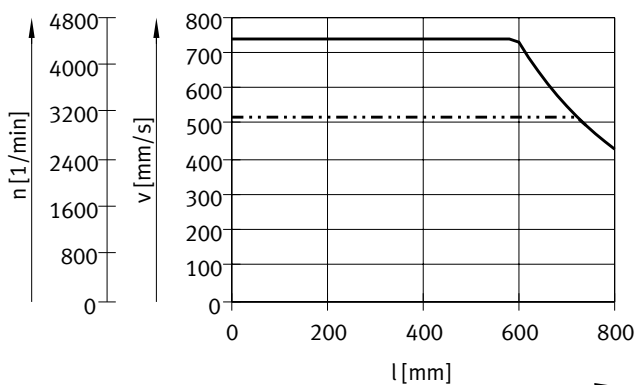

— EGSK-46- ... -10P-P  
 - - - - EGSK-46- ... -10P, EGSK-46- ... -10P-H

EGSK-46-...-20P

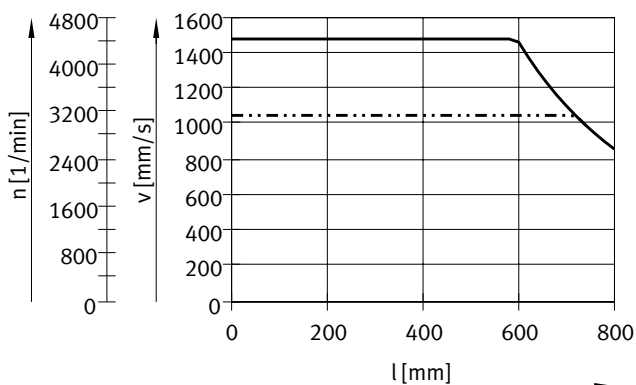

— EGSK-46- ... -20P-P  
 - - - - EGSK-46- ... -20P, EGSK-46- ... -20P-H

2nd moments of area

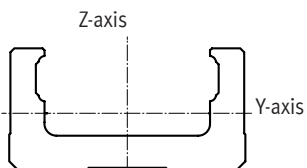

Size		15	20	26	33	46
$I_y$	[mm <sup>4</sup> ]	908	6100	17000	62000	240000
$I_z$	[mm <sup>4</sup> ]	14200	62000	150000	380000	1 500000

## Data sheet

### Characteristic load values

The indicated forces and torques refer to the centre axis of the spindle. The coordinate zero point is the point where the centre of the guide and the longitudinal centre of the slide intersect.

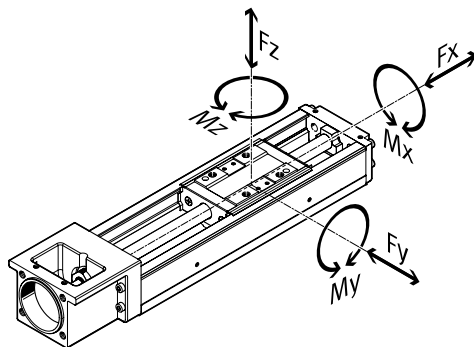

**Note**  
 Engineering software  
 Electric Motion Sizing  
[www.festo.com](http://www.festo.com)

### Permissible dynamic forces and torques<sup>1)</sup>

Size			15 <sup>2)</sup>		20		26		33		46	
Spindle pitch			1	2	1	6	2	6	6	10	10	20
	Code <sup>2)</sup>											
$F_{y\max}, F_{z\max}$	-/H <sup>4)</sup>	- [N]	747	593	1389	764	2223	1541	2469	2083	4919	3904
	P <sup>5)</sup>	- [N]	1 185	941	2204	1213	3528	2446	3920	3306	7809	6198
	-/H <sup>4)</sup>	S [N]	-	-	-	-	-	-	1043	880	2514	1995
	P <sup>5)</sup>	S [N]	-	-	-	-	-	-	1656	1396	3990	3167
$M_{x\max}$	-/H <sup>4)</sup>	- [Nm]	8.2	6.5	18.1	9.9	37.8	26.2	50.1	42.2	145	115
	P <sup>5)</sup>	- [Nm]	13	10.3	28.7	15.8	60	41.6	79.5	67.1	231	183
	-/H <sup>4)</sup>	S [Nm]	-	-	-	-	-	-	21.2	17.8	74.4	59
	P <sup>5)</sup>	S [Nm]	-	-	-	-	-	-	33.6	28.3	118	93.7
$M_{y\max}, M_{z\max}$	-/H <sup>4)</sup>	- [Nm]	2.3	1.9	5.8	3.2	12.9	8.9	16.4	13.8	48.7	38.7
	P <sup>5)</sup>	- [Nm]	3.7	2.9	9.2	5.1	20.4	14.1	26	21.9	77.3	61.4
	-/H <sup>4)</sup>	S [Nm]	-	-	-	-	-	-	3.8	3.2	13.6	10.8
	P <sup>5)</sup>	S [Nm]	-	-	-	-	-	-	6	5	21.6	17.1

- 1) Calculated with a speed-dependent load factor  $f_w$  of 1.2
- 2) Variant code → page 8
- 3) Size 15 is only available in the accuracy classes H and P
- 4) Loads are based on a specified service life of  $5 \times 10^8$  revolutions and load factor  $f_w=1.2$
- 5) Loads are based on a specified service life of  $1.25 \times 10^8$  revolutions and load factor  $f_w=1.2$

### Basic load ratings

Size			15 <sup>2)</sup>		20		26		33		46	
Spindle pitch			1	2	1	6	2	6	6	10	10	20
	Code <sup>1)</sup>											
<b>Ball screw</b>												
Static $C_{0\text{BDS}}$	-/H	[N]	660	410	1170	1450	4020	3510	4900	2840	6760	7150
	P	[N]	660	410	1170	1600	4020	3900	2740	1570	3720	5290
Dynamic $C_{\text{dynBDS}}$	-/H <sup>3)</sup>	[N]	340	230	660	860	2350	1950	2840	1760	3140	3040
	P <sup>3)</sup>	[N]	340	230	660	1060	2350	2390	2250	1370	2940	3430
<b>Fixed bearing</b>												
Static $C_{0\text{bearing}}$		[N]	290		1240		1760		2590		3240	
Dynamic $C_{\text{dynbearing}}^3)$		[N]	590		1000		1380		1790		6660	

- 1) Variant code → page 8
- 2) Size 15 is only available in the accuracy classes H and P
- 3) Dynamic basic load ratings are based on a basic service life of  $10^6$  revolutions

## Data sheet

Basic load ratings			15 <sup>2)</sup>		20		26		33		46	
Size			1	2	1	6	2	6	6	10	10	20
Spindle pitch												
	Code <sup>1)</sup>											
<b>Linear guide</b>												
Static $C_{0,guide}$	-	[N]	3450		6300		12150		20200		45500	
	S	[N]	-		-		-		10000		22700	
Dynamic $C_{dyn,guide}$ <sup>3)</sup>	-	[N]	1532		2849		5746		9207		21747	
	S	[N]	-		-		-		3889		11112	
<b>Torque equivalence factors</b>												
$k_x$	-	[1/m]	90.9		76.9		58.8		49.3		33.8	
	S	[1/m]	-		-		-		49.3		33.8	
$k_y, k_z$	-	[1/m]	319.9		238.7		172.9		151		101	
	S	[1/m]	-		-		-		277.1		185	

1) Variant code → page 8

2) Size 15 is only available in the accuracy classes H and P

3) Dynamic basic load ratings are based on a basic service life of 100 km

Speed-dependent load factor  $f_w$  $f_w = 1.0 \dots 1.2$  ( $v \leq 0.25$  m/s) $f_w = 1.2 \dots 1.5$  ( $0.25$  m/s  $\leq v \leq 1.0$  m/s) $f_w = 1.5 \dots 2.0$  ( $1.0$  m/s  $\leq v \leq 2.0$  m/s) $f_w = 2.0 \dots 3.5$  ( $v \geq 2.0$  m/s)Calculation of the maximum feed force  $F_x$ 

$$F_{x,max} = \frac{1}{f_w} \cdot \frac{\text{Min} [C_{dyn,KGT}, C_{dyn,bearing}]}{\sqrt[3]{\frac{L_{ref,rot}}{10^6}}}$$

Calculation of the maximum forces  $F_{y/z}$  and torques  $M_{x/y/z}$ 

$$F_{y/z,max} = \frac{1}{f_w} \cdot \frac{C_{dyn,guide}}{\sqrt[3]{\frac{L_{ref,km}}{100 km}}}$$

$$M_{x,y,z,max} = \frac{1}{k_{x,y,z}} \cdot \frac{1}{f_w} \cdot \frac{C_{dyn,guide}}{\sqrt[3]{\frac{L_{ref,km}}{100 km}}}$$

## Data sheet

Calculating the service life													
Size	15			20			26			33		46	
Spindle pitch P													
	Code <sup>1)</sup>												
Reference service life in revolutions, $L_{ref,rot}$	-/H	$5 \times 10^8$											
	P	$1.25 \times 10^8$											
Reference service life in kilometres, $L_{ref,km}$	-/H	[km]	500	1000	500	3000	1000	3000	3000	5000	5000	10000	
	P	[km]	125	250	125	750	250	750	750	1250	1250	2500	

1) Variant code → page 8

### [1] Determining the loads over the travel cycle

$$q_1 = t_1 / t_{total} \quad q_2 = t_2 / t_{total} \quad q_3 = t_3 / t_{total}$$

$$t_{total} = t_1 + t_2 + t_3$$

v	Speed
$t_1$	Acceleration time
$t_2$	Constant travel time
$t_3$	Deceleration time
$q_{1/2/3}$	Relative time of the cycle phases
$t_{total}$	Cycle time

### Ball screw

$$\text{For } t_1: F_{x1} = -(m \times a) - (M_{no-load} \times 2\pi/P)$$

$$\text{For } t_2: F_{x2} = -(M_{no-load} \times 2\pi/P)$$

$$\text{For } t_3: F_{x3} = -(m \times a) - (M_{no-load} \times 2\pi/P)$$

$$F_{x,dyn} = \sqrt[3]{q_1 \cdot |F_{x1}^3| + q_2 \cdot |F_{x2}^3| + q_3 \cdot |F_{x3}^3|}$$

$F_{x1/2/3}$	Calculated force load per cycle phase
$F_{x,dyn}$	Calculated average force load
m	Payload (centre of gravity)
a	Acceleration
$M_{no-load}$	No-load torque → page 9
P	Spindle pitch → page 9
$q_{1/2/3}$	Relative time of the cycle phases

## Data sheet

## [1] Determining the loads over the travel cycle

## Linear guide

For  $t_1$ :  $a \neq 0, v >$ 

$$F_{y1} = 0$$

$$F_{z1} = m \times g$$

$$M_{x1} = F_z \times y_0 = m \times g \times y_0$$

$$M_{y1} = -F_z \times x_0 + F_x \times z_0 = -m \times g \times x_0 + m \times a \times z_0$$

$$M_{z1} = F_x \times y_0 = m \times a \times y_0$$

For  $t_2$ :  $a = 0, v >$ 

$$F_{y2} = 0$$

$$F_{z2} = m \times g$$

$$M_{x2} = F_z \times y_0 = m \times g \times y_0$$

$$M_{y2} = -F_z \times x_0 = -m \times g \times x_0$$

$$M_{z2} = 0$$

For  $t_3$ :  $a <, v >$ 

$$F_{y3} = 0$$

$$F_{z3} = m \times g$$

$$M_{x3} = F_z \times y_0 = m \times g \times y_0$$

$$M_{y3} = -F_z \times x_0 - F_x \times z_0 = -m \times g \times x_0 - m \times a \times z_0$$

$$M_{z3} = -F_x \times y_0 = -m \times a \times y_0$$

$$F_{y,dyn} = \sqrt[3]{q_1 \cdot |F_{y1}^3| + q_2 \cdot |F_{y2}^3| + q_3 \cdot |F_{y3}^3|}$$

$$F_{z,dyn} = \sqrt[3]{q_1 \cdot |F_{z1}^3| + q_2 \cdot |F_{z2}^3| + q_3 \cdot |F_{z3}^3|}$$

$$M_{x,dyn} = \sqrt[3]{q_1 \cdot |M_{x1}^3| + q_2 \cdot |M_{x2}^3| + q_3 \cdot |M_{x3}^3|}$$

$$M_{y,dyn} = \sqrt[3]{q_1 \cdot |M_{y1}^3| + q_2 \cdot |M_{y2}^3| + q_3 \cdot |M_{y3}^3|}$$

$$M_{z,dyn} = \sqrt[3]{q_1 \cdot |M_{z1}^3| + q_2 \cdot |M_{z2}^3| + q_3 \cdot |M_{z3}^3|}$$

 $F_{y1/2/3}$  $F_{z1/2/3}$  $M_{x1/2/3}$  $M_{y1/2/3}$  $M_{z1/2/3}$  $F_{y/z,dyn}$  $M_{x/y/z,dyn}$  $m$  $g$  $a$  $x_0, y_0, z_0$  $q_{1/2/3}$ 

Calculated force load per cycle phase

Calculated torque load per cycle phase

Calculated average force load

Calculated average torque load

Payload (centre of gravity)

Gravitational acceleration

Acceleration

Distances between the centre of gravity of the payload and the slide centre point

Relative time of the cycle phases

## [2] Total load

## Ball screw

$$\frac{|F_{x,dyn}|}{F_{x,max}} \leq 1$$

 $F_{x,dyn}$  Calculated average force load $F_{x,max}$  Max. permissible force load → page 9 $f_v$  Load comparison factor → page 16

## Linear guide

$$f_v = \frac{|F_{y1}|}{F_{y2}} + \frac{|F_{z1}|}{F_{z2}} + \frac{|M_{x1}|}{M_{x2}} + \frac{|M_{y1}|}{M_{y2}} + \frac{|M_{z1}|}{M_{z2}} \leq 1$$

 $F_{y/z,dyn}$  Calculated average force load $F_{y/z,max}$  Max. permissible force load → page 12 $M_{x/y/z,dyn}$  Calculated average torque load $M_{x/y/z,max}$  Max. permissible torque load → page 12 $f_v$  Load comparison factor → page 16

## Data sheet

### [3] Determination of the load comparison factor $f_v$

$$f_v = \frac{1}{\sqrt[3]{q}} \quad q = \frac{L_{calc,km}}{L_{ref,km}} = \frac{L_{calc,rot}}{L_{ref,rot}}$$

for  $q = 1$ :

Calculated service life (here desired service life)

$L_{calc,km} = 1 \times$  reference service life  $L_{ref,km}$

gives  $f_v = 1$

for  $q \neq 1$ :

Calculated service life (here desired service life)

$L_{calc,km} = q \times$  reference service life  $L_{ref,km}$

read off ( $\rightarrow$  graph) or calculate  $f_v$

$f_v$	Load comparison factor
$q$	Quotient of desired service life divided by reference service life
$L_{calc, km}$	Calculated service life in km
$L_{ref, km}$	Reference service life in km $\rightarrow$ page 14
$L_{calc, rot}$	Calculated service life in revolutions
$L_{ref, rot}$	Reference service life in revolutions $\rightarrow$ page 14

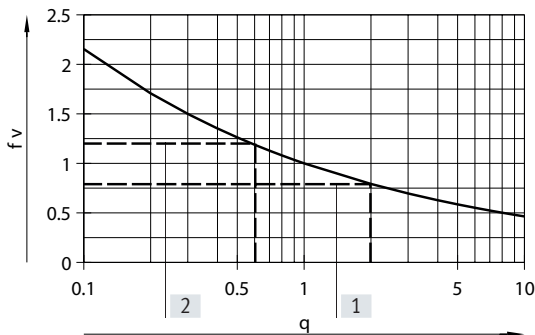

- [1] Example 1
- [2] Example 2

### [4] Calculation examples

#### Example 1:

EGSK-26-...-2P-H...

$L_{ref,km} = 1000$  km

$L_{calc,km} = 2000$  km

$$q = \frac{2000km}{1000km} = 2,0$$

$$f_v = \frac{1}{\sqrt[3]{q}} = 0,79$$

Result:

A desired service life of 200% of the reference service life means that the permissible total load must be 21% lower.

#### Example 2:

If the total load calculation gives a load comparison factor  $f_v = 1.2$ , the mathematical service life is only approx. 60% ( $x = 0.6 \rightarrow$  graph) of the reference service life.

$$q = \frac{1}{f_v^3} = 0,58$$

### [4] Static sizing

#### Ball screw

$$F_{x,stat} = \text{Max}[F_{x1}, F_{x2}, F_{x3}] \leq \frac{C_{0,KGT}}{f_s}$$

$F_{x,stat}$	Maximum value of the calculated force load per cycle phase
$F_{x1/2/3}$	Calculated force load per cycle phase
$C_{0,BSD}$	Static basic load rating of ball screw $\rightarrow$ page 12
$f_s$	Safety factor against static overload $f_s = 1.0 \dots 3.0$

#### Linear guide

$$F_{y,stat} = \text{Max}[F_{y1}, F_{y2}, F_{y3}] \leq \frac{C_{0,guide}}{f_s}$$

$$F_{z,stat} = \text{Max}[F_{z1}, F_{z2}, F_{z3}] \leq \frac{C_{0,guide}}{f_s}$$

$$M_{x,stat} = \text{Max}[M_{x1}, M_{x2}, M_{x3}] \leq \frac{1}{k_x} \cdot \frac{C_{0,guide}}{f_s}$$

$$M_{y,stat} = \text{Max}[M_{y1}, M_{y2}, M_{y3}] \leq \frac{1}{k_y} \cdot \frac{C_{0,guide}}{f_s}$$

$$M_{z,stat} = \text{Max}[M_{z1}, M_{z2}, M_{z3}] \leq \frac{1}{k_z} \cdot \frac{C_{0,guide}}{f_s}$$

$F_{y/z,stat}$	Maximum value of the calculated force load per cycle phase
$M_{x/y/z,stat}$	Maximum value of the calculated torque load per cycle phase
$F_{y1/2/3}$ , $F_{z1/2/3}$	Calculated force load per cycle phase
$M_{x1/2/3}$ , $M_{y1/2/3}$ , $M_{z1/2/3}$	Calculated torque load per cycle phase
$C_{0,guide}$	Static basic load rating of ball screw $\rightarrow$ page 13
$k_{x/y/z}$	Torque equivalence factors $\rightarrow$ page 13
$f_s$	Safety factor against static overload $f_s = 1.0 \dots 3.0$



Data sheet

Dimensions

Download CAD data → [www.festo.com](http://www.festo.com)

EGSK-15

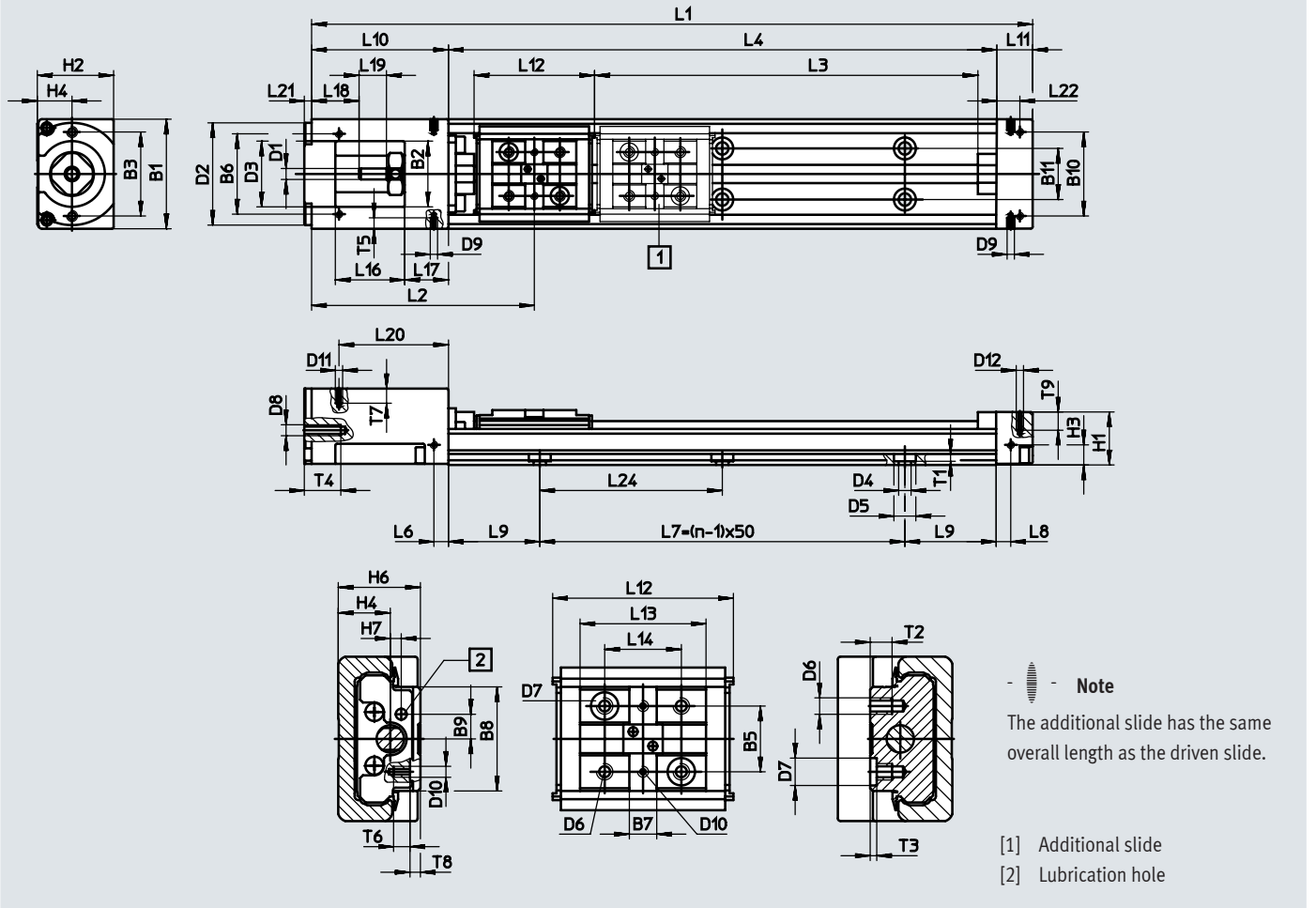

Size	Stroke	L1	L3 +4	L4	L7	L9	n
15	25	122.5	30	75	50	12.5	2
	50	147.5	55	100	50	25	2
	75	172.5	80	125	100	12.5	3
	100	197.5	105	150	100	25	3

Size	B1	B2	B3	B5	B6	B7	B8	B9	B10	B11	D1	D2	D3	D4	D5	D6	D7	D8
15	30	18	±0.1	±0.02	±0.1	5	19	4.5	±0.1	14	∅ h6	∅ g7	∅	∅	∅	M3	∅ H7	M3

Size	D9	D10	D11	D12	H1	H2	H3	H4	H6	H7	L2	L6	L8	L10	L11	L12	L13	L14
15	M2	M2	M2	M2	14.5	20.9	5.5	9.5	15	2	60.3	4	4	37.5	10	33	23	±0.02 14

Size	L16	L17	L18	L19	L20	L21	L22	L24	T1	T2	T3	T4	T5	T6	T7	T8	T9
15	19	12	13	7.5	±0.1 30	2	±0.1 6.5	50	2	4	+0.1 1.2	10	3	3	4	1.9	5

Data sheet

Dimensions

Download CAD data → [www.festo.com](http://www.festo.com)

EGSK-20/26

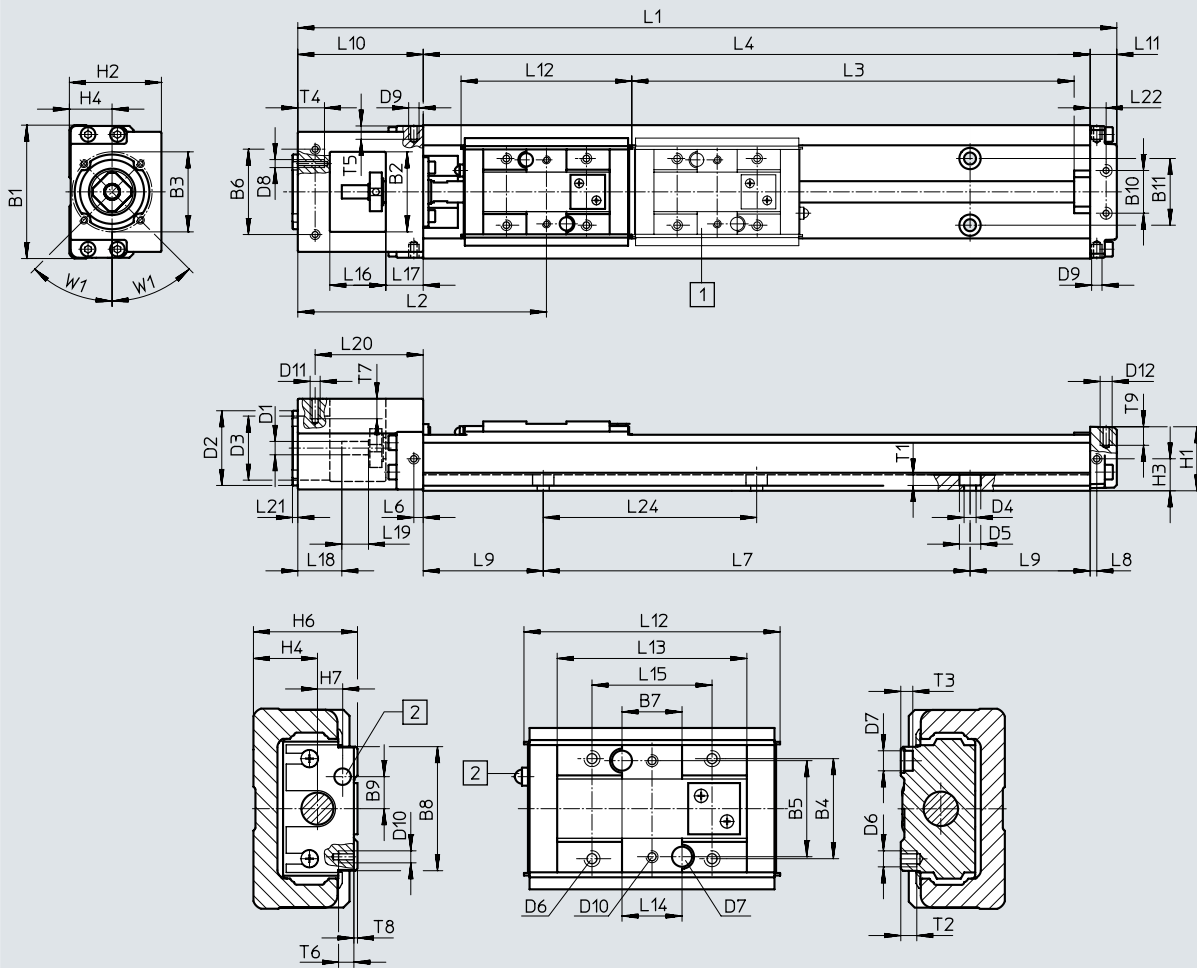

Note

The additional slide has the same overall length as the driven slide.

- [1] Additional slide
- [2] Lubrication nipple

Size	Stroke	L1	L3 +4	L4	L7= (n-1)x60	L9	n	Size	Stroke	L1	L3 +4	L4	L7= (n-1)x80	L9	n
20	25	152	40	100	60	20	2	26	50	207	67	150	80	35	2
	75	202	90	150	120	15	3		100	257	117	200	160	20	3
	125	252	140	200	120	40	3		150	307	167	250	160	45	3
									200	357	217	300	240	30	4

## Data sheet

Size	B1	B2	B3 ∅	B4	B5 ±0.02	B6 ±0.1	B7	B8	B9	B10 ±0.1	B11	D1 ∅ h7	D2 ∅ g7	D3 ∅
20	40	22	30	18	18	29	10	23	5	18	18	4	28	22
26	50	30	30	25	24	32	15	31	8	16	25	5	28	24

Size	D4 ∅	D5 ∅	D6	D7 ∅ H7	D8	D9	D10	D11	D12	H1	H2	H3	H4	H6
20	3.4	6.5	M3	2	M3	M2.6	M2	M2.5	M2.5	19	28	10	13	20
26	4.5	8	M4	5	M3	M2.6	M3	M2.5	M3	24	34.5	12	16	26

Size	H7	L2	L6	L8	L10	L11	L12	L13	L14 <sup>1)</sup> ±0.02	L15	L16	L17	L18	L19
20	3.4	72.5	3.5	2.5	42	10	46	33.2	10	20	18	12	16	8
26	6	91	3.5	2.5	47	10	64	47.4	15	30	21	14	16.5	10

Size	L20 ±0.1	L21	L22 ±0.1	L24	T1	T2	T3	T4	T5	T6	T7	T8	T9	W1
20	34.5	2	6.5	60	3	4.5	3	10	4	5	5	0.9	5	45°
26	40.5	2	6	80	4	6.5	3	10	4	6	5	0.9	6	45°

1) Distance between the locating holes

Data sheet

Dimensions

Download CAD data → [www.festo.com](http://www.festo.com)

EGSK-33/46

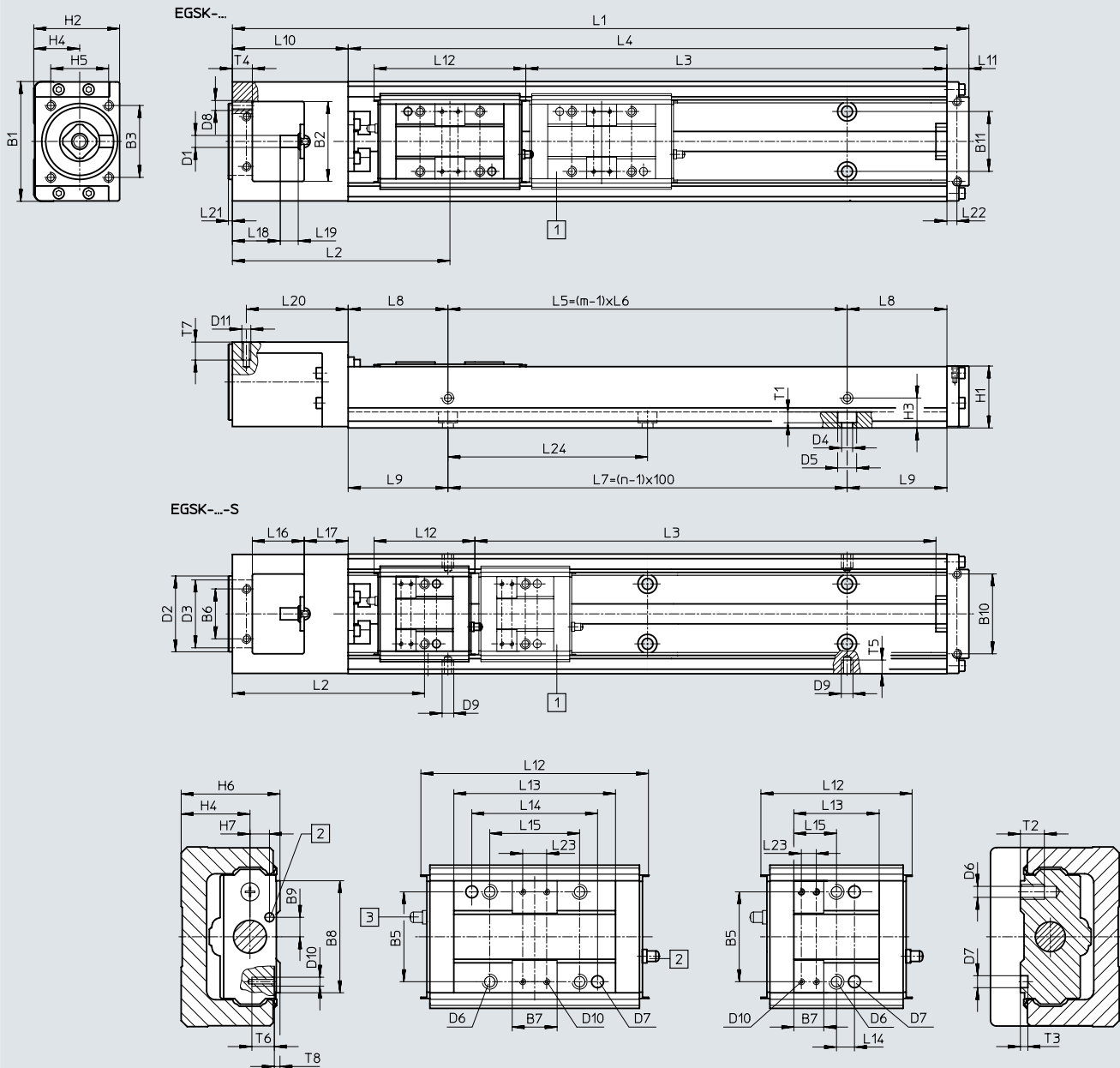

Note

The additional slide has the same overall length as the driven slide.

- [1] Additional slide
- [2] Lubrication nipple

- [3] The lubrication nipple is in the direction of the drive cover on the version with additional slide (EGSK-...-Z)

## Data sheet

Size	Stroke	L1	L3 +4		L4	L5	L6	L7	L8	m	n
			S								
33	100	269	110	135	200	100	100	100	50	2	2
	200	369	210	235	300	200	200	200	50	2	3
	300	469	310	335	400	200	200	300	100	2	4
	400	569	410	435	500	400	200	400	50	3	5
	500	669	510	535	600	400	200	500	100	3	6
	600	769	610	635	700	600	200	600	50	4	7

Size	Stroke	L1	L3 +4		L4	L5	L6	L7	L8	m	n
			S								
46	200	425.5	206	244	340	200	200	200	70	2	3
	300	525.5	306	344	440	400	200	300	20	3	4
	400	625.5	406	444	540	400	200	400	70	3	5
	500	725.5	506	544	640	600	200	500	20	4	6
	600	825.5	606	644	740	600	200	600	70	4	7
	800	1 025.5	806	844	940	800	200	800	70	5	9

Size	B1	B2	B3 ±0.1	B5 ±0.04	B6 ±0.1	B7	B8	B9	B10 ±0.1	B11	D1 ∅ h7	D2 ∅ g7	D3 ∅	D4 ∅	D5 ∅
46	86	48	36	46	42	15	54.4	10	58	46	8	38	34	6.6	11

Size	D6	D7 ∅ H7	D8	D9	D10	D11	H1	H2	H3	H4	H5 ±0.1	H6	H7	L2	
														S	
33	M5	4	M5	M2.6	M2	M3	31	43	15	23	29	33	6.5	105	92.3
46	M6	5	M5	M2.6	M2	M4	43.5	60	28	32	29	46	9	142.5	123.8

Size	L9	L10	L11	L12		L13		L14		L15 S	L16	L17	L18	L19	
				S		S		±0.04	±0.1						
33	50	58	11	76	50.5	54	28.5	42	6	30	14.25	26	22	24	9
46	70	72.5	13	110	72.5	81	43.5	28	11	46	21.75	33.5	25	21.5	18

Size	L20 ±0.1	L21	L22 ±0.1	L23		L24	T1	T2	T3	T4	T5	T6	T7	T8
				S										
33	51	2	5	8	5	100	5.4	8	2.5	10	4	5	6	1
46	65.5	2	3.5	8	8	100	6.5	12	2.5	10	4	5	8	1

Data sheet

Ordering data – Electric slides with standard slide				Part no.	Type
Size	Stroke [mm]	Part no.	Type		
<b>Spindle pitch 1 mm</b>				<b>Spindle pitch 6 mm</b>	
20	25	562758	EGSK-20-25-1P	562761	EGSK-20-25-6P
	75	562759	EGSK-20-75-1P	562762	EGSK-20-75-6P
	125	562760	EGSK-20-125-1P	562763	EGSK-20-125-6P
<b>Spindle pitch 2 mm</b>				<b>Spindle pitch 6 mm</b>	
26	50	562764	EGSK-26-50-2P	562768	EGSK-26-50-6P
	100	562765	EGSK-26-100-2P	562769	EGSK-26-100-6P
	150	562766	EGSK-26-150-2P	562770	EGSK-26-150-6P
	200	562767	EGSK-26-200-2P	562771	EGSK-26-200-6P
<b>Spindle pitch 6 mm</b>				<b>Spindle pitch 10 mm</b>	
33	100	562772	EGSK-33-100-6P	562778	EGSK-33-100-10P
	200	562773	EGSK-33-200-6P	562779	EGSK-33-200-10P
	300	562774	EGSK-33-300-6P	562780	EGSK-33-300-10P
	400	562775	EGSK-33-400-6P	562781	EGSK-33-400-10P
	500	562776	EGSK-33-500-6P	562782	EGSK-33-500-10P
	600	562777	EGSK-33-600-6P	562783	EGSK-33-600-10P
<b>Spindle pitch 10 mm</b>				<b>Spindle pitch 20 mm</b>	
46	200	562784	EGSK-46-200-10P	562790	EGSK-46-200-20P
	300	562785	EGSK-46-300-10P	562791	EGSK-46-300-20P
	400	562786	EGSK-46-400-10P	562792	EGSK-46-400-20P
	500	562787	EGSK-46-500-10P	562793	EGSK-46-500-20P
	600	562788	EGSK-46-600-10P	562794	EGSK-46-600-20P
	800	562789	EGSK-46-800-10P	562795	EGSK-46-800-20P

## Ordering data – Modular product system

Ordering table							Conditions	Code	Enter code	
Size	15	20	26	33	46					
Module no.	<b>562749</b>	<b>562750</b>	<b>562751</b>	<b>562752</b>	<b>562753</b>					
Drive function	Electric slide drive							EGSK	EGSK	
Size	15	20	26	33	46			-...	-...	
Standard stroke [mm] for standard slide	25		-					-25	-...	
	50	-	50	-				-50	-...	
	75		-					-75	-...	
	100	-	100	-				-100	-...	
	-	125	-					-125	-...	
	-		150	-				-150	-...	
	-		200	-				-200	-...	
	-			300	-			-300	-...	
	-			400	-			-400	-...	
	-			500	-			-500	-...	
	-			600	-			-600	-...	
					800			-800	-...	
Standard stroke [mm] for short slide	-			130	-			-130	-...	
	-			230	-			-230	-...	
	-				240	-			-240	-...
	-			330	-			-330	-...	
	-				340	-			-340	-...
	-			430	-			-430	-...	
	-				440	-			-440	-...
	-			530	-			-530	-...	
	-				540	-			-540	-...
	-			630	-			-630	-...	
	-				640	-			-640	-...
					840			-840	-...	
Spindle pitch [mm]	1		-					-1P	-...	
	2	-	2	-				-2P	-...	
	-	6	-					-6P	-...	
	-	-	-	10	-			-10P	-...	
	-				20			-20P	-...	
Accuracy	-	Standard accuracy						-	-...	
		Enhanced accuracy						-H	-...	
		Precision accuracy				[1]		-P	-...	
Slide design	Standard slide							-	-...	
	-			Slide, short					-S	
Additional slide	No additional slide							-	-...	
	Additional slide (additional slide Z in combination with slide design S also results in a short slide)						[2]		-Z	

[1] P With size 33 not in combination with stroke for standard slide 600 and stroke for short slide 630  
With size 46 not in combination with stroke for standard slide 800 and stroke for short slide 840

[2] Z With size 15 not in combination with stroke for standard slide 25 and stroke for standard slide 50  
With size 20 not in combination with stroke for standard slide 25  
With size 26 not in combination with stroke for standard slide 50  
With size 33 not in combination with stroke for standard slide 100

Accessories

Data sheets → Internet: eamm-a

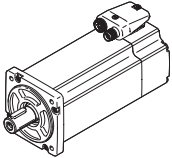
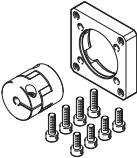
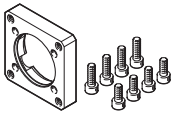
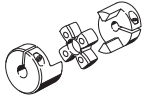
Permissible axis/motor combinations with axial kit – Without gear unit			
Motor	Axial kit	Axial kit comprises:	
		Motor flange	Coupling
			
Type	Part no. Type	Part no. Type	Part no. Type
<b>EGSK-15</b>			
<b>With servo motor</b>			
EMME-AS-40-...	1982886 EAMM-A-P3-28D-40P	1982014 EAMF-A-28D-40P	2310368 EAMC-16-20-3-8
<b>With stepper motor</b>			
EMMS-ST-28-...	1703478 EAMM-A-P3-28D-28A	1087613 EAMF-A-28D-28A	562672 EAMC-16-20-3-5
<b>EGSK-20</b>			
<b>With servo motor</b>			
EMME-AS-40-...	1983071 EAMM-A-P4-28B-40P	1976704 EAMF-A-28B-40P	562675 EAMC-16-20-4-8
<b>With stepper motor</b>			
EMMS-ST-28-...	1731466 EAMM-A-P4-28B-28A	1704476 EAMF-A-28B-28A	562674 EAMC-16-20-4-5
EMMS-ST-42-...	562636 EAMM-A-P4-28B-42A	552164 EAMF-A-28B-42A	562674 EAMC-16-20-4-5
<b>EGSK-26</b>			
<b>With servo motor</b>			
EMME-AS-40-...	1983122 EAMM-A-P5-28B-40P	1976704 EAMF-A-28B-40P	562677 EAMC-16-20-5-8
<b>With stepper motor</b>			
EMMS-ST-28-...	1731474 EAMM-A-P5-28B-28A	1704476 EAMF-A-28B-28A	562676 EAMC-16-20-5-5
EMMS-ST-42-...	562640 EAMM-A-P5-28B-42A	552164 EAMF-A-28B-42A	562676 EAMC-16-20-5-5
<b>EGSK-33</b>			
<b>With servo motor</b>			
EMME-AS-40-...	1983450 EAMM-A-P6-38A-40P	1984478 EAMF-A-38A-40P	533708 EAMC-30-32-6-8
EMMT-AS-60-..., EMME-AS-60-...	2264375 EAMM-A-P6-38A-60P	1987412 EAMF-A-38A-60P	1233256 EAMC-30-32-6-14
<b>With stepper motor</b>			
EMMS-ST-42-...	562644 EAMM-A-P6-38A-42A	562668 EAMF-A-38A-42A	561333 EAMC-30-32-5-6
EMMS-ST-57-...	562645 EAMM-A-P6-38A-57A	560692 EAMF-A-38A-57A	551002 EAMC-30-32-6-6.35
<b>With integrated drive</b>			
EMCA-EC-67-...	2297641 EAMM-A-P6-38A-67A	1490100 EAMF-A-38A-67A	551003 EAMC-30-32-6-9

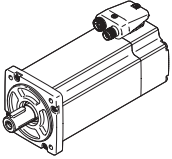
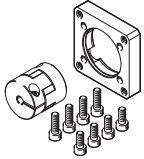
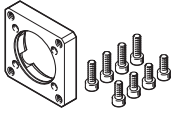
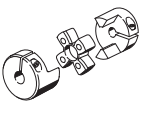

## Accessories

Permissible axis/motor combinations with axial kit – Without gear unit				Data sheets → Internet: eamm-a
Motor	Axial kit	Axial kit comprises:		
		Motor flange	Coupling	
				
Type	Part no. Type	Part no. Type	Part no. Type	
<b>EGSK-46</b>				
<b>With servo motor</b>				
EMME-AS-40-...	1986292 EAMM-A-P8-38A-40P	1984478 EAMF-A-38A-40P	543422 EAMC-30-32-8-8	
EMMT-AS-60-..., EMME-AS-60-...	1987308 EAMM-A-P8-38A-60P	1987412 EAMF-A-38A-60P	562682 EAMC-30-32-8-14	
<b>With stepper motor</b>				
EMMS-ST-42-...	562650 EAMM-A-P8-38A-42A	562668 EAMF-A-38A-42A	562678 EAMC-30-32-5-8	
EMMS-ST-57-...	562651 EAMM-A-P8-38A-57A	560692 EAMF-A-38A-57A	543421 EAMC-30-32-6.35-8	
EMMS-ST-87-...	564998 EAMM-A-P8-38A-87A	560693 EAMF-A-38A-87A	551004 EAMC-30-32-8-11	
<b>With integrated drive</b>				
EMCA-EC-67-...	2297643 EAMM-A-P8-38A-67A	1490100 EAMF-A-38A-67A	543423 EAMC-30-32-8-9	

Accessories

Data sheets → Internet: eamm-a

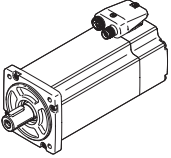
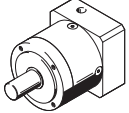
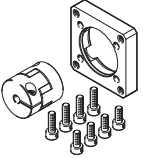
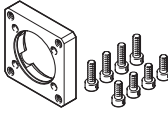
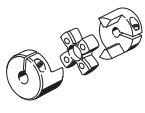
Permissible axis/motor combinations with axial kit – With gear unit				
Motor	Gear unit	Axial kit	Axial kit comprises:	
			Motor flange	Coupling
				
Type	Type	Part no. Type	Part no. Type	Part no. Type
<b>EGSK-33</b>				
<b>With servo motor</b>				
EMME-AS-40-...	EMGA-40-P-G...-EAS-40	2297645 EAMM-A-P6-38A-40G	1460097 EAMF-A-38A-40G	562681 EAMC-30-32-6-10
<b>With stepper motor</b>				
EMMS-ST-42-...	EMGA-40-P-G...-SST-42	2297645 EAMM-A-P6-38A-40G	1460097 EAMF-A-38A-40G	562681 EAMC-30-32-6-10
<b>With integrated drive</b>				
EMCA-EC-67-...	EMGC-40-...	2297645 EAMM-A-P6-38A-40G	1460097 EAMF-A-38A-40G	562681 EAMC-30-32-6-10
<b>EGSK-46</b>				
<b>With servo motor</b>				
EMME-AS-40-...	EMGA-40-P-G...-EAS-40	2297646 EAMM-A-P8-38A-40G	1460097 EAMF-A-38A-40G	558029 EAMC-30-32-8-10
<b>With stepper motor</b>				
EMMS-ST-42-...	EMGA-40-P-G...-SST-42	2297646 EAMM-A-P8-38A-40G	1460097 EAMF-A-38A-40G	558029 EAMC-30-32-8-10
<b>With integrated drive</b>				
EMCA-EC-67-...	EMGC-40-...	2297646 EAMM-A-P8-38A-40G	1460097 EAMF-A-38A-40G	558029 EAMC-30-32-8-10

## Accessories

### Cross connecting kit EHAM

Material:

Adapter plate: Anodised aluminium

Screws, dowel pins: Steel

RoHS-compliant

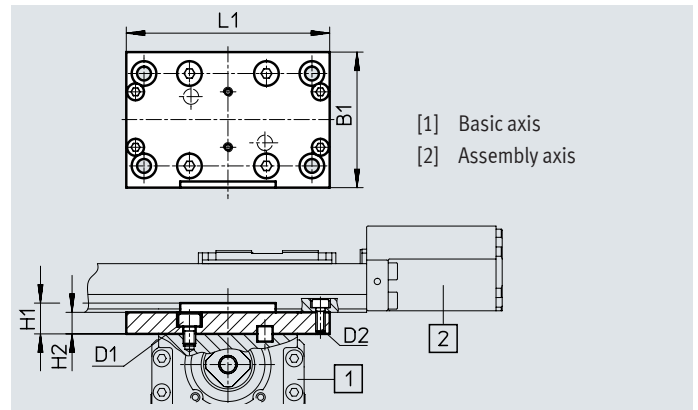
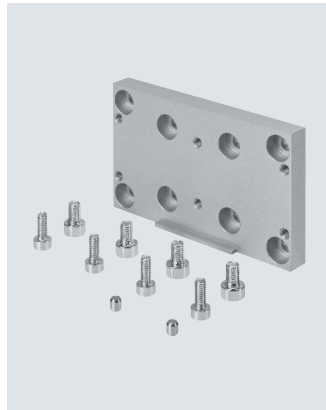

[1] Basic axis

[2] Assembly axis

#### Dimensions and ordering data

For size		B1	D1	D2	H1	H2	L1	Weight [g]	Part no.	Type
Basic axis [1]	Assembly axis [2]	±0.2					±0.2			
20	15	33.2	M3	M3	7	5	56	27	563747	EHAM-S1-20-15
26	20	44	M4	M3	10	7	66	59	563748	EHAM-S1-26-20
33	26	54	M5	M4	12	9	86	124	563749	EHAM-S1-33-26
46	33	65	M6	M5	15	10	112	216	563750	EHAM-S1-46-33

Accessories

Slide adapter EASA

Material:  
 Adapter plate: Anodised aluminium  
 Screws, dowel pins: Steel  
 RoHS-compliant

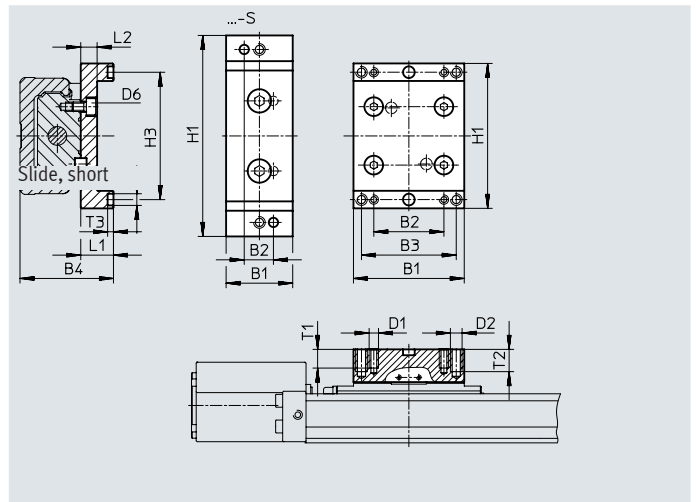
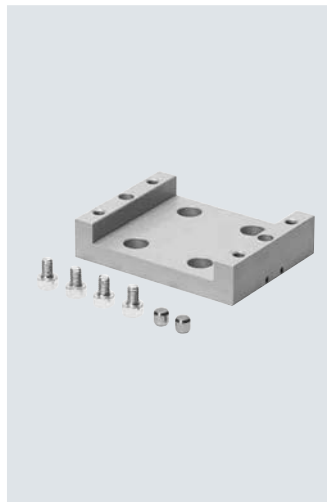

Dimensions and ordering data

For size	B1	B2	B3	B4	D1	D2	D3 ∅ H7	D6	H1	H3
	±0.2								±0.2	+0.04

With standard slide

15	23	14	-	25	M3	-	4	M3	44	38
20	33.2	23		32	M3		2	M3	52	44.5
26	47.4	30		40	M4		5	M4	62	54.5
33	54	40		48	M5		4	M5	86	74
46	81	30	48	68	M5	M6	5	M6	112	100

With short slide

33	28.5	12.5	-	48	M5	-	4	M5	86	74
46	48	22		68	M6		5	M6	112	100

For size	L1	L2	T1	T2	T3	Weight [g]	Part no.	Type
	+0.05				+0.1			

With standard slide

15	10	5.4	6	-	2.5	20	562742	EASA-S1-15
20	12	6	6		2.5	38	562743	EASA-S1-20
26	14	7	8		2.5	74	562744	EASA-S1-26
33	15	9	15		2.6	130	562745	EASA-S1-33
46	22	10	10	12	2.6	310	562746	EASA-S1-46

With short slide

33	15	9	15	-	2.6	70	562747	EASA-S1-33-S
46	22	10	12		2.6	180	562748	EASA-S1-46-S

Accessories

Covering kit EASC  
for standard slide

Material:  
Cover profile, adapter plate, adapter:  
Anodised wrought aluminium alloy  
Screws, dowel pins: Steel  
RoHS-compliant

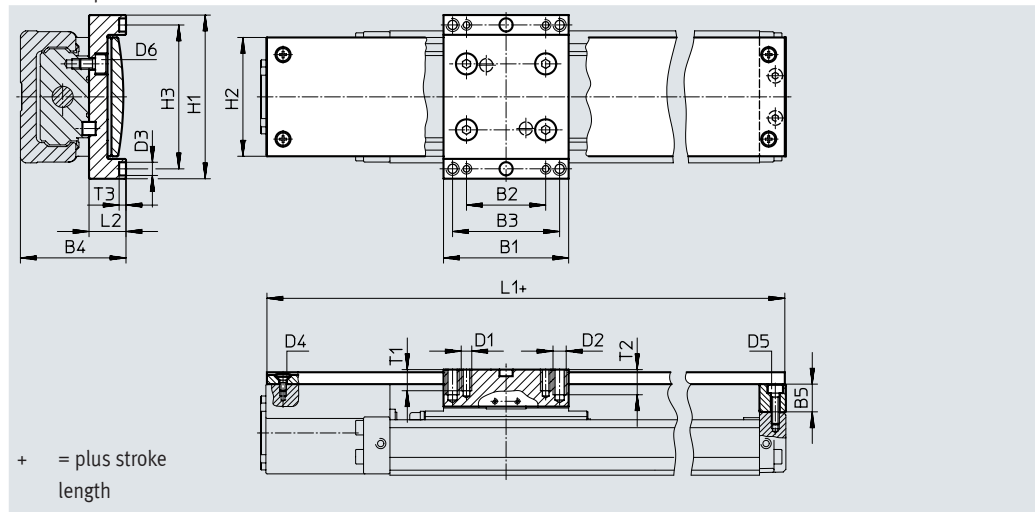
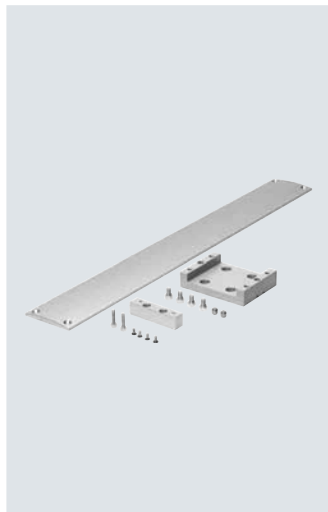

Dimensions										
For size	B1	B2	B3	B4	B5	D1	D2	D3 ∅ H7	D4	D5
	±0.2									
15	23	14	-	25	6.5	M3	-	4	M2	M2
20	33.2	23		32	9	M3		2	M2.5	M2.5
26	47.4	30		40	10.5	M4		5	M2.5	M3
33	54	40		48	7	M5		4	M3	M3
46	81	30	48	68	10	M5	M6	5	M4	M4

For size	D6	H1	H2	H3	L1	L2	T1	T2	T3
		±0.2	±0.2	±0.04	-0.3				+0.1
15	M3	44	30	38	96.7	10	6	-	2.5
20	M3	52	35.6	44.5	126.2	12	6		2.5
26	M4	62	45	54.5	156.2	14	8		2.5
33	M5	86	62.5	74	168.2	15	15		2.6
46	M6	112	82.4	100	224.7	22	10	12	2.6

Ordering data										
For size	Stroke [mm]	Weight [g]	Part no.	Type	For size	Stroke [mm]	Weight [g]	Part no.	Type	
15	25	51	562707	EASC-S1-15-25	33	100	327	562718	EASC-S1-33-100	
	50	57	562708	EASC-S1-15-50		200	391	562719	EASC-S1-33-200	
	75	62	562709	EASC-S1-15-75		300	454	562720	EASC-S1-33-300	
	100	67	562710	EASC-S1-15-100		400	518	562721	EASC-S1-33-400	
20	25	92	562711	EASC-S1-20-25		500	581	562722	EASC-S1-33-500	
	75	107	562712	EASC-S1-20-75		600	645	562723	EASC-S1-33-600	
	125	121	562713	EASC-S1-20-125		46	200	850	562724	EASC-S1-46-200
26	50	187	562714	EASC-S1-26-50			300	965	562725	EASC-S1-46-300
	100	211	562715	EASC-S1-26-100			400	1080	562726	EASC-S1-46-400
	150	234	562716	EASC-S1-26-150			500	1200	562727	EASC-S1-46-500
	200	258	562717	EASC-S1-26-200	600		1310	562728	EASC-S1-46-600	
					800		1540	562729	EASC-S1-46-800	

## Accessories

### Covering kit EASC for short slide

Material:  
Cover profile, adapter plate, adapter:  
Anodised aluminium  
Screws, dowel pins: Steel  
RoHS-compliant

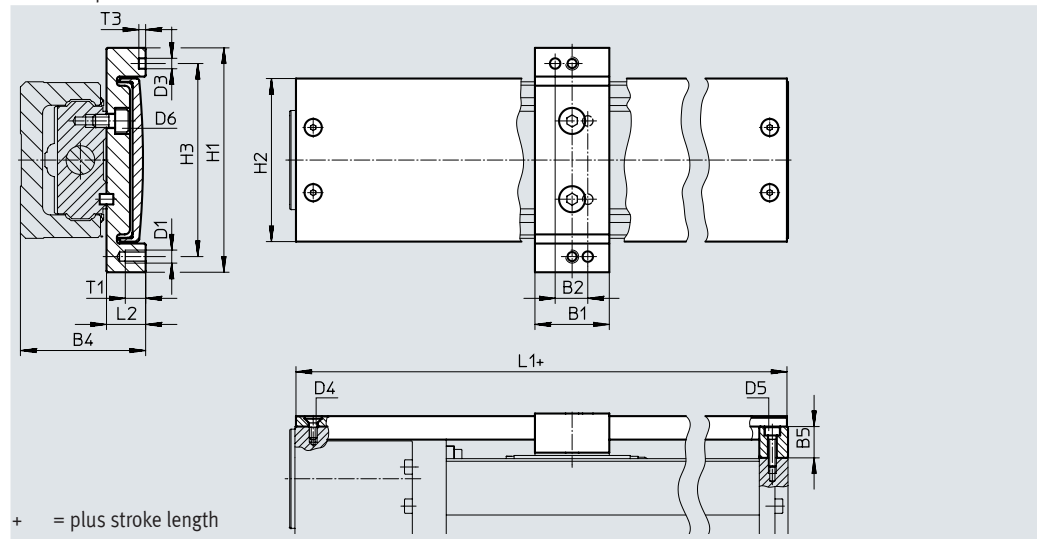

#### Dimensions

For size	B1	B2	B4	B5	D1	D3 ∅	D4	D5
33	±0.2	±0.04						
33	28.5	12.5	48	7	M5	4	M3	M3
46	48	22	68	10	M6	5	M4	M4

For size	D6	H1	H2	H3	L1	L2	T1	T3
		±0.2	±0.2	±0.04	-0.3			+0.1
33	M5	86	62.5	74	138.2	15	15	2.6
46	M6	112	82.4	100	184.7	22	12	2.6

#### Ordering data

For size	Stroke [mm]	Weight [g]	Part no.	Type
33	130	263	562730	EASC-S1-33-130-S
	230	328	562731	EASC-S1-33-230-S
	330	391	562732	EASC-S1-33-330-S
	430	454	562733	EASC-S1-33-430-S
	530	518	562734	EASC-S1-33-530-S
	630	581	562735	EASC-S1-33-630-S
46	240	724	562736	EASC-S1-46-240-S
	340	840	562737	EASC-S1-46-340-S
	440	955	562738	EASC-S1-46-440-S
	540	1070	562739	EASC-S1-46-540-S
	640	1190	562740	EASC-S1-46-640-S
	840	1420	562741	EASC-S1-46-840-S

## Accessories

### Sensor rail EAPR

Material:

Sensor bracket: anodised aluminium

Switch lug, screws: galvanised steel

RoHS-compliant

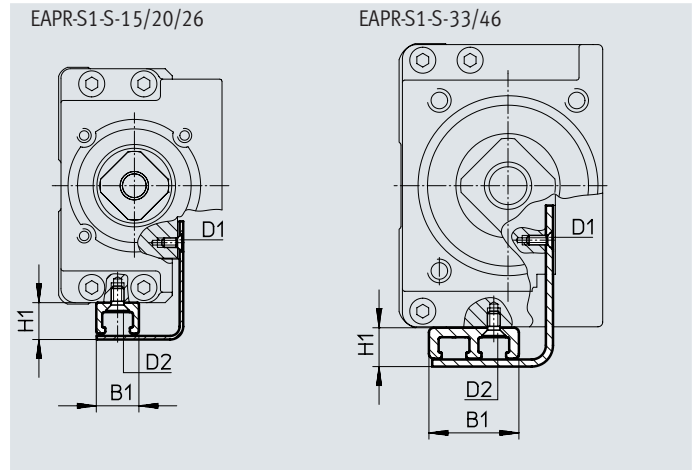

Dimensions				
For size	B1	H1	D1	D2
<b>With standard slide</b>				
15	9	8.5	M2	M2
20	9	7.75	M2	M2.5
26	9	7.75	M3	M2.5
33	19	7.75	M2	M2.5
46				
<b>With short slide</b>				
33	19	7.5	M2	M2.5
46		8.5	M2	M2.5



Ordering data					
For size	Stroke	Weight	Part no.	Type	
For type	[mm]	[g]			
<b>With standard slide</b>					
15	25	10	562611	EAPR-S1-S-15-25	
	50	12	562612	EAPR-S1-S-15-50	
	75	14	562613	EAPR-S1-S-15-75	
	100	16	562614	EAPR-S1-S-15-100	
20	25	14	562615	EAPR-S1-S-20-25	
	75	18	562616	EAPR-S1-S-20-75	
	125	22	562617	EAPR-S1-S-20-125	
26	50	24	562618	EAPR-S1-S-26-50	
	100	28	562619	EAPR-S1-S-26-100	
	150	32	562620	EAPR-S1-S-26-150	
	200	37	562621	EAPR-S1-S-26-200	
<b>With standard slide or short slide</b>					
33	100/130-S	51	562622	EAPR-S1-S-33-100/130-S	
	200/230-S	69	562623	EAPR-S1-S-33-200/230-S	
	300/330-S	88	562624	EAPR-S1-S-33-300/330-S	
	400/430-S	106	562625	EAPR-S1-S-33-400/430-S	
	500/530-S	125	562626	EAPR-S1-S-33-500/530-S	
	600/630-S	144	562627	EAPR-S1-S-33-600/630-S	
46	200/240-S	78	562628	EAPR-S1-S-46-200/240-S	
	300/340-S	97	562629	EAPR-S1-S-46-300/340-S	
	400/440-S	115	562630	EAPR-S1-S-46-400/440-S	
	500/540-S	134	562631	EAPR-S1-S-46-500/540-S	
	600/640-S	153	562632	EAPR-S1-S-46-600/640-S	
	800/840-S	190	562633	EAPR-S1-S-46-800/840-S	

Accessories

Ordering data – Centring pins, centring sleeves					
	For size	Comment	Part no.	Type	PU <sup>1)</sup>
	15	For slide	189652	ZBH-5	10
	20		525273	ZBS-2	
	26, 46		150928	ZBS-5	
	33		562959	ZBS-4	
	15, 33	For slide adapter	562959	ZBS-4	
	20		525273	ZBS-2	
	26, 46		150928	ZBS-5	

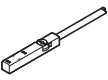
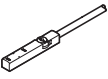
1) Packaging unit

Ordering data – Proximity switches for T-slot, inductive						Data sheets → Internet: sies
	Type of mounting	Switching output	Electrical connection	Cable length [m]	Part no.	Type
<b>N/O contact</b>						
	Inserted in the slot from above, flush with the sensor rail	PNP	Cable, 3-wire	7.5	551386	SIES-8M-PS-24V-K-7.5-OE
			Plug M8x1, 3-pin	0.3	551387	SIES-8M-PS-24V-K-0.3-M8D
		NPN	Cable, 3-wire	7.5	551396	SIES-8M-NS-24V-K-7.5-OE
			Plug M8x1, 3-pin	0.3	551397	SIES-8M-NS-24V-K-0.3-M8D
<b>N/C contact</b>						
	Inserted in the slot from above, flush with the sensor rail	PNP	Cable, 3-wire	7.5	551391	SIES-8M-PO-24V-K-7.5-OE
			Plug M8x1, 3-pin	0.3	551392	SIES-8M-PO-24V-K-0.3-M8D
		NPN	Cable, 3-wire	7.5	551401	SIES-8M-NO-24V-K-7.5-OE
			Plug M8x1, 3-pin	0.3	551402	SIES-8M-NO-24V-K-0.3-M8D

Ordering data – Connecting cables					Data sheets → Internet: nebu
	Electrical connection, left	Electrical connection, right	Cable length [m]	Part no.	Type
	Straight socket, M8x1, 3-pin	Cable, open end, 3-wire	2.5	541333	NEBU-M8G3-K-2.5-LE3
			5	541334	NEBU-M8G3-K-5-LE3
	Angled socket, M8x1, 3-pin	Cable, open end, 3-wire	2.5	541338	NEBU-M8W3-K-2.5-LE3
			5	541341	NEBU-M8W3-K-5-LE3



# Festo - Your Partner in Automation



**1 Festo Inc.**  
5300 Explorer Drive  
Mississauga, ON L4W 5G4  
Canada

**Festo Customer Interaction Center**  
Tel: 1 877 463 3786  
Fax: 1 877 393 3786  
Email: [customer.service.ca@festo.com](mailto:customer.service.ca@festo.com)

**2 Festo Pneumatic**  
Av. Ceylán 3,  
Col. Tequesquináhuac  
54020 Tlalneantla,  
Estado de México

**Multinational Contact Center**  
01 800 337 8669  
[ventas.mexico@festo.com](mailto:ventas.mexico@festo.com)

**3 Festo Corporation**  
1377 Motor Parkway  
Suite 310  
Islandia, NY 11749

**Festo Customer Interaction Center**  
1 800 993 3786  
1 800 963 3786  
[customer.service.us@festo.com](mailto:customer.service.us@festo.com)

**4 Regional Service Center**  
7777 Columbia Road  
Mason, OH 45040

Connect with us



[www.festo.com/socialmedia](http://www.festo.com/socialmedia)



[www.festo.com](http://www.festo.com)

Subject to change