

# spirax sarco

TI-P193-01  
 MI Issue 4

## TFA

# Flowmeter for Saturated Steam Service

### Description

The Spirax Sarco TFA flowmeter is designed for use on saturated steam only and operates on the target principle, by measuring the force produced on a target by the fluid flow. This force is then converted into density compensated mass flowrate or power and is transmitted via a single loop powered 4-20 mA and pulsed output. TFA flowmeters also incorporate a totalised flow function and EIA 232C (RS232) or EIA 485C (RS485) Modbus communications.

**Where applicable the installation requires:** 2 x Centralising bushes over the lower two bolts of the flange connection - See the selection table for 'Centralising bush kits' on page 4).

**Note:** The centralising bush kit must be ordered for the installation flange type used on your application - See 'How to order' on page 4 for a typical example.

### Sizes and pipe connections

The TFA flowmeter is of wafer design, available in the listed specified sizes suitable for fitting between the following flanges:

DN25, DN32, DN40 and DN50  
 Flanged EN 1092-1 PN16, PN25 and PN40,  
 Japanese Industrial Standard JIS 20 and  
 Korean Standard KS 20

1", 1¼", 1½" and 2"  
 Flanged ASME B 16.5 Class 150 and Class 300

**Note:**

The Spirax Sarco TFA flowmeter should be installed in pipework manufactured to BS 1600, ASME B 36.10 Schedule 40 or EN 10216-2 / EN 10216-5 equivalent. For systems with different standards / schedules, please contact Spirax Sarco.

### Technical data

IP rating	IP65 with correct cable glands
Power supply	Loop powered with optional RS485: 24VDC
Outputs - proportional to mass flow or power	4-20mA (not available with RS485 option) Pulsed output: $V_{max}$ 28 Vdc $R_{min}$ 10 kΩ
Communication port	Modbus EIA 232C (RS 232C) with optional RS485: EIA 485 (RS 485C)

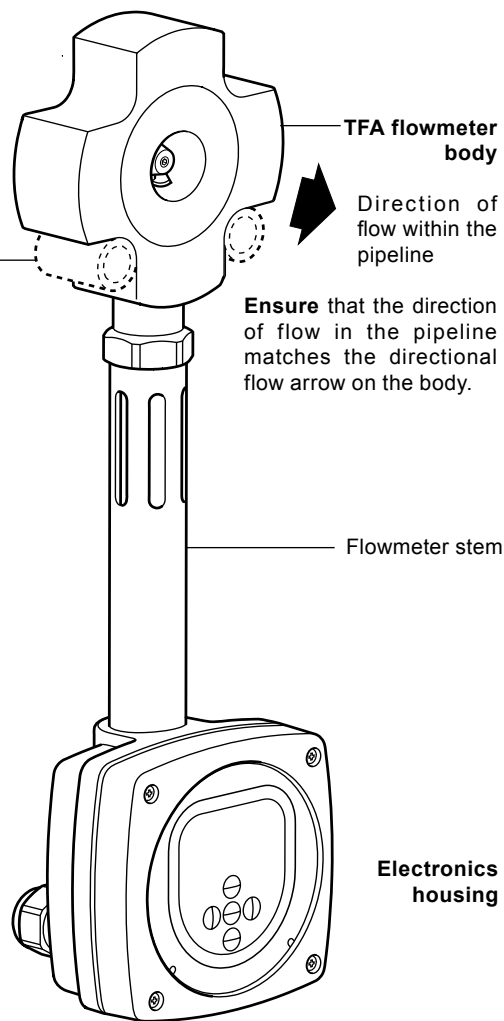

### Materials

<b>Flowmeter body</b>	Stainless steel 300 series
<b>Internals</b>	Stainless steel 431 S29 / 300 series
<b>Flowmeter stem</b>	Stainless steel 300 series
<b>Electronics housing</b>	Aluminium LM25

### Performance

The TFA flowmeter has inbuilt electronics which give a density compensated output. The LCD display is incorporated within the electronics head and can show totaliser, flowrate, power, pressure and temperature. An M750 display unit can be used to provide a remote display function if required, utilising the 4 - 20 mA output.

**System uncertainty, to 95% confidence (2 STD): (in accordance with ISO 17025)**

±2% of measured value from ≥20% and ≤100% of maximum rated flow  
 ±2% of full-scale value from ≥10% and <20% of maximum rated flow  
 Turndown : up to 10:1

As the TFA flowmeter is a self contained unit, the uncertainty quoted is for the complete system. Many flowmeters claim a pipeline unit uncertainty but for a true system uncertainty, the individual uncertainty values of any associated equipment, such as DP cells, need to be added to the pipeline value.

## Pressure/temperature limits

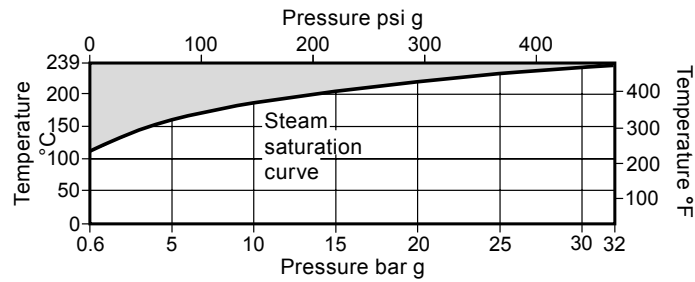

The product should not be used in this region due to software limitations.

Maximum design pressure	32 bar g @ 239 °C	(464 psi g @ 462°F)
Maximum design temperature	239 °C	(462°F)
Minimum design temperature	0 °C (non-freezing)	32°F (non-freezing)
* Maximum operating pressure	Horizontal flow	32 bar g @ 239 °C (464 psi g @ 462°F)
	Vertical flow	7 bar g @ 170 °C (101 psi g @ 338°F)
* <b>Note:</b> See the Installation and Maintenance Instructions supplied with the TFA (IM-P193-02 and IM-P193-03) for full operation restrictions		
Minimum operating pressure	0.6 bar g	(8.7 psi g)
Maximum operating temperature (saturation)	239 °C	(462°F)
Maximum electronics ambient temperature	55 °C	(131°F)
Maximum electronics humidity level	90% RH (non-condensing)	90% RH (non-condensing)
Designed for a maximum cold hydraulic test pressure of	52 bar g	(754 psi g)

## Differential pressure drop

### mbar

%Qmax	10%	20%	30%	40%	50%	60%	70%	80%	90%	100%
DN25	6	25	56	100	156	225	306	399	505	624
DN32	5	19	43	76	118	170	232	303	383	473
DN40	3	10	23	42	65	94	127	166	210	260
DN50	2	6	14	25	39	56	76	100	126	156

### Inches H<sub>2</sub>O

%Qmax	10%	20%	30%	40%	50%	60%	70%	80%	90%	100%
DN25	2.5	10.0	22.5	40.1	62.6	90.1	122.7	160.2	202.8	250.4
DN32	1.9	7.6	17.1	30.4	47.5	68.3	93.0	121.5	153.8	189.8
DN40	1.0	4.2	9.4	16.7	26.1	37.6	51.1	66.8	84.5	104.3
DN50	0.6	2.5	5.6	10.0	15.6	22.5	30.7	40.1	50.7	62.6

## Dimensions / weights

(approximate) in mm and kg

Size	A	B	C	D	E	Weight
DN25	35	105	323	80	105	2.85
DN32						2.95
DN40						2.86
DN50						2.91

(approximate) in inches and lbs

Size	A	B	C	D	E	Weight
DN25	1.38	4.13	12.72	3.15	4.13	6.28
DN32						6.50
DN40						6.30
DN50						6.41

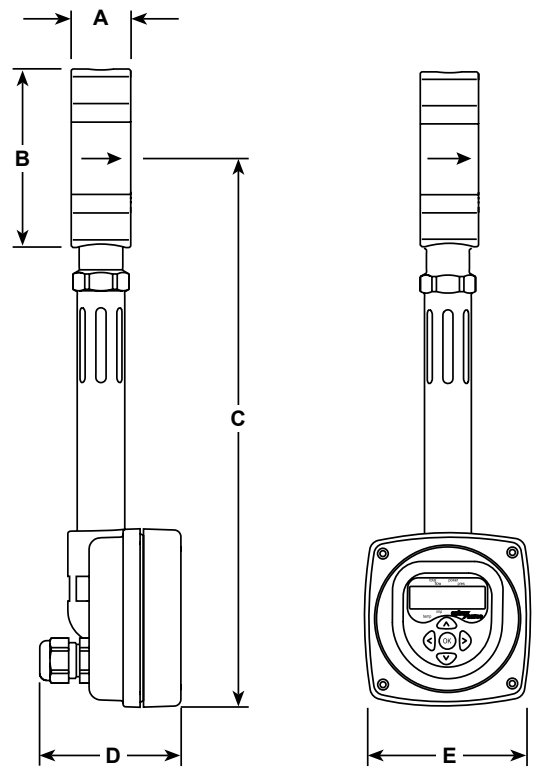

## Sizing the TFA flowmeter for saturated steam - Horizontal orientation

Notes:

- 1 - Maximum steam flowrates are calculated at maximum differential pressure.
- 2 - For vertical capacities please contact Spirax Sarco.
- 3 - The tables below are a guide only.

## Flow in kg/h

Maximum flowrates in kg/h at different pressures bar g.

Size	Steam pressure bar g	1	2	3	4	5	6	7	8	9	10	12	15	20	25	30	32
DN25	Maximum flow	155	187	215	239	260	281	299	316	333	349	378	418	479	534	584	603
	Minimum flow	15	19	21	24	26	28	30	32	33	35	38	42	48	53	58	60
DN32	Maximum flow	254	307	352	391	427	460	490	519	546	572	621	686	786	876	957	989
	Minimum flow	25	31	35	39	43	46	49	52	55	57	62	69	79	88	96	99
DN40	Maximum flow	396	480	550	611	667	718	765	809	853	894	969	1071	1227	1367	1494	1544
	Minimum flow	40	48	55	61	67	72	77	81	85	89	97	107	123	137	149	154
DN50	Maximum flow	619	749	859	955	1042	1122	1196	1265	1333	1396	1514	1673	1918	2136	2335	2412
	Minimum flow	62	75	86	95	104	112	120	126	133	140	151	167	192	214	233	241

## Flow in lb/h

Maximum flowrates in lb/h at different pressures psi g.

Size	Steam pressure psi g	14.5	29	44	58	73	87	102	116	131	145	174	218	290	363	435	464
DN25	Maximum flow	342	412	474	527	573	619	659	697	734	769	833	922	1056	1177	1287	1329
	Minimum flow	33	42	46	53	57	62	66	71	73	77	84	93	106	117	128	132
DN32	Maximum flow	560	677	776	862	941	1014	1080	1144	1204	1261	1369	1512	1733	1931	2110	2180
	Minimum flow	55	68	77	86	95	101	108	115	121	126	137	152	174	194	212	218
DN40	Maximum flow	873	1058	1213	1347	1470	1583	1687	1784	1881	1971	2136	2361	2705	3014	3294	3404
	Minimum flow	88	106	121	134	148	159	170	179	187	196	214	236	271	302	328	340
DN50	Maximum flow	1365	1651	1894	2105	2297	2474	2637	2789	2939	3078	3338	3688	4228	4709	5148	5318
	Minimum flow	137	165	190	209	229	247	265	278	293	309	333	368	423	472	514	531

## Safety information, installation and maintenance

For full details see the Installation and Maintenance Instructions (IM-P193-02 and IM-P193-03) supplied with the product.

The following main points are given for guidance only:

1. The TFA flowmeter should be mounted with the 'concave' side of the target facing upstream, with a minimum of 6 straight pipe diameters upstream and 3 downstream. No valves, fittings or cross sectional changes are permitted within these pipe lengths. Where an increase in nominal pipe diameter is required, upstream of the flowmeter, the length of straight pipe should be increased to 12 diameters. Similarly, where a flowmeter is installed downstream of two 90° bends in two planes, a pressure reducing valve or a partly open valve, 12 upstream pipe diameters should be allowed.
2. It is important that the internal upstream and downstream diameters of pipe are smooth. Ideally seamless pipes should be used and there should be no intrusive weld beads on the internal diameter.
3. The TFA flowmeter must be installed concentrically in the line using the centralising bush kit (ordered separately). If this is not done, flow measurement errors may occur.
4. The TFA flowmeter can be installed in any orientation up to a line pressure of 7 bar g (102 psi g).
5. As with all steam flowmetering installations, good basic steam engineering practices should be followed:
  - Correct line drainage through adequate trapping.
  - Good alignment and support of associated pipework.
  - Line size changes achieved by the use of eccentric reducers.
  - Do not lag (insulate) the TFA body or the mating flanges.

### Centralising bush kits

TFA size	Flange type			
	EN 1092 PN16 PN25 PN40	ASME 150	ASME 300	JIS 20 KS 20
DN25 1"	1930283		1930283	1930283
DN32 1¼"	1930283		1930283	1930283
DN40 1½"	1930283		1930483	
DN50 2"	1930283	1930283	1930583	

### How to order

**Example:** 1 off Spirax Sarco DN25 TFA flowmeter supplied with centralising bush kit 1930283 suitable for mounting between EN 1092 PN40 flanges for use on saturated steam at 10 bar g - Maximum flow 349 kg/h.

**Note:** For details of the optional remote display see the relevant Spirax Sarco M750 literature.

#### Software copyright

Certain computer programs contained in this product [or device] were developed by Spirax-Sarco Limited ('the Work(s)').

Copyright © Spirax-Sarco Limited 2016

#### All Rights Reserved

Spirax-Sarco Limited grants the legal user of this product (or device) the right to use the Work(s) solely within the scope of the legitimate operation of the product (or device). No other right is granted under this licence. In particular and without prejudice to the generality of the foregoing, the Work(s) may not be used, sold, licensed, transferred, copied or reproduced in whole or in part or in any manner or form other than as expressly granted here without the prior written consent of Spirax-Sarco Limited.