

API 603 GATE VALVES

BOLTED BONNET, ASME CLASSES 150-600
 FLANGED OR BUTTWELD ENDS
 CAST STAINLESS STEEL

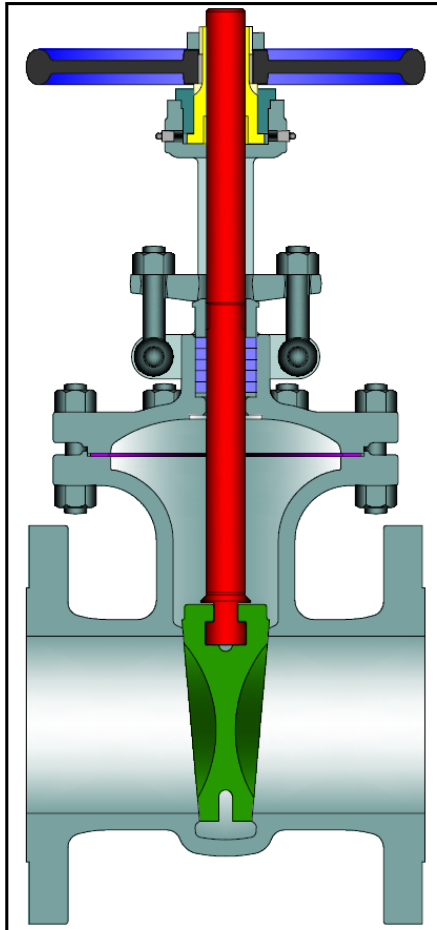

Class	Fig. No.
150	2456
300	2467 (4)
600	1973 (4)

DESIGN FEATURES:

- Seat face: Ground and lapped to a smooth finish.
- Flexible Wedge with low center stem – wedge contact. Wedge is ground and lapped to a smooth finish and tightly guided to prevent dragging and seat damage.
- Non-rotating stem with precision ACME threads and burnished finish. Double start ACME thread for faster operation.
- Body and bonnet joint accurately machined. Gasket materials and details on page 6.
- Body and bonnet castings are precision machined. One-piece bonnet up to 12" (350 mm) valve size on all classes.
- Gland has two-piece construction for easy alignment.

- Flanges:
 - » Classes 150-300: 1/16" raised face.
 - » Class 600: 1/4" raised face.
 - » Finish 125-250 AARH for all valves.
- Rotating stem nut is Austenitic ductile iron Gr D2 renewable in line. Thrust bearings are supplied as follows:
 - » Class 150 & 300 14" (400 mm) and larger valve size.
 - » Class 600 6" (150 mm) and larger valve size.

- Heavier walled API 600 design available.
- Classes above 600 are available; see the API 600 catalog.
- Other available options as follows:
 - » Alternate valve materials available
 - » Bypass, drain and other auxiliary connections
 - » Gear, motor, and cylinder actuators available
 - » NACE service
 - » Special cleaning for applications such as oxygen or chlorine
 - » Other options available as specified

STANDARD MATERIALS (Other materials available)

PART	MATERIALS
Body	A351 Gr. CF8M (2)
Bonnet	A351 Gr. CF8M
Wedge	A351 Gr. CF8M
Stem	SST 316
Stem Bushing	A 439 Ductile NI-Resist Gr. D2
Stem Bushing Lock Nut	Series 300 SST
Gland Flange	A351 Gr. CF8M
Eye Bolt	A193 Gr. B8
Eye Bolt Nut	A194 Gr.8
Groove Pin	Series 300 SST
Gland	SST 316
Packing	PTFE (3)
Packing Washer / Packing Spacer	SST 316
Gasket	PTFE (3)
Hand Wheel	Malleable Iron or Steel
Hand Wheel Nut	Malleable Iron or Steel
Key	Steel
Lubricant Fitting	Steel
Body / Bonnet Stud	A193 Gr. B8
Body / Bonnet Nut	A194 Gr.8
Yoke arm (1)	A351 CF8
Bonnet / Yoke arm Stud (1)	A193 Gr. B8
Bonnet / Yoke arm Nut (1)	A194 Gr.8
Bearing Cap (1)	Series 300 SST
Cap Screws (1)	
Identification Plate	

1. 14" Valve sizes and up all classes have a two piece yoke.
2. CF3M for weld end bodies.
3. For API 603 compliance, optional graphitic packing and gasket are required.
4. See pages 8-9 for 2" and smaller sizes with threaded or socket weld ends.

Design Specifications

Item	Applicable Specification
Wall thickness	API 603 + B16.34
Pressure - temperature ratings	ASME B16.34
General valve design	API 603 & B16.34
End to End dimensions	ASME B16.10
Flange design	ASME B16.5
Butt Weld design	ASME B16.25
Materials	ASTM

GATE VALVE DIMENSIONS (CLASSES 150 -600)

SIZE in mm	ASME 150						ASME 300					ASME 600				
	A		B(1)	C(1)	D	E	A	B(1)	C(1)	D	E	A	B(1)	C(1)	D	E
FE	WE															
½	4.25	4.25	7.2	7.8	0.50	3.5	5.50	7.2	7.9	0.50	3.5	6.50	7.3	7.9	0.50	3.5
13	109	108	183	198	13	89	140	183	200	13	89	165	185	202	13	89
¾	4.63	4.63	7.7	8.6	0.75	4.0	6.00	7.9	8.9	0.75	4.0	7.50	8.0	8.9	0.75	4.0
19	117	117	196	219	19	102	152	201	225	19	102	191	203	225	19	102
1	5.00	5.00	8.3	9.4	1.00	4.5	6.50	8.3	9.4	1.00	4.5	8.50	8.6	9.8	1.00	5.0
25	127	127	211	240	25	114	165	211	240	25	114	216	218	248	25	127
1½	6.50	6.50	10.4	12.1	1.50	5.0	7.50	10.4	12.1	1.50	6.0	9.50	10.7	12.4	1.50	7.0
38	165	165	264	308	38	127	191	264	308	38	152	241	272	316	38	178
2	7.00	8.50	12.0	14.3	2.00	6.0	8.50	12.0	14.3	2.00	7.0	11.50	12.3	14.3	2.00	9.0
50	178	216	305	362	51	152	216	305	362	51	178	292	312	362	51	229
2½	7.50	9.50	12.3	15.0	2.50	7.0	9.50	12.6	14.3	2.50	7.9	13.00	18.1	21.9	2.50	12.0
65	191	241	312	380	64	178	241	319	364	64	201	330	461	555	64	305
3	8.00	11.12	13.8	17.0	3.00	7.0	11.12	13.8	17.0	3.00	9.0	14.00	19.2	22.8	3.00	12.0
80	203	282	350	431	76	178	283	350	431	76	229	356	487	580	76	305
4	9.00	12.00	16.8	20.9	4.00	9.0	12.00	16.8	20.9	4.00	10.0	17.00	23.0	27.5	4.00	14.0
100	229	305	427	530	102	229	305	426	530	102	254	432	585	698	102	356
6	10.50	15.88	22.2	28.3	6.00	11.0	15.88	22.6	28.7	6.00	14.0	22.00	32.5	39.1	6.00	20.0
150	267	403	563	720	152	279	403	574	730	152	356	559	825	993	152	508
8	11.50	16.50	29.3	38.0	8.00	14.0	16.50	30.6	39.2	8.00	16.0	26.00	35.0	45.4	7.87	22.0
200	292	419	744	965	203	356	419	777	995	203	406	660	890	1154	200	560
10	13.00	18.00	35.6	46.3	10.00	16.0	18.00	36.8	47.2	10.00	20.0	31.00	41.9	52.4	9.75	25.2
250	330	457	905	1175	254	406	457	935	1199	254	508	787	1065	1332	248	640
12	14.00	19.75	41.1	53.5	12.00	18.0	19.75	42.6	54.7	12.00	20.0	33.00	47.3	59.9	11.75	26.8
300	356	502	1045	1359	305	457	502	1082	1390	305	508	838	1202	1521	298	680
14	15.00	22.50	46.3	60.3	13.25	20.0	30.00	49.1	63.4	13.25	22.0	35.00	51.6	65.4	12.87	28.3
350	381	572	1175	1531	337	508	762	1248	1611	337	560	889	1310	1662	327	720
16	16.00	24.00	51.6	67.9	15.25	22.0	33.00	70.7	85.3	15.25	25.2	39.00	73.2	91.1	14.75	35.4
400	406	610	1310	1725	387	560	838	1796	2387	387	640	991	1860	2461	375	900
18	17.00	26.00	58.1	76.4	17.25	25.2	36.00	77.2	94.3	17.00	26.8	43.00	79.1	99.1	16.5	35.4
450	432	660	1477	1940	438	640	914	1961	2643	432	680	1092	2008	2643	419	900
20	18.00	28.00	63.3	83.3	19.25	26.7	38.88	85.3	106.3	19.00	28.2	46.75	85.3	108.3	18.25	28.0
500	457	711	1615	2123	489	680	991	2176	2913	483	720	1194	2166	2913	464	710
24	20.00	32.00	76.7	101.1	23.25	28.3	45.00	100.9	128.3	23.00	35.4	55.00	102.3	128.3	22.00	32.0
600	508	813	1948	2568	591	720	1143	2562	3413	584	900	1397	2599	3413	559	810

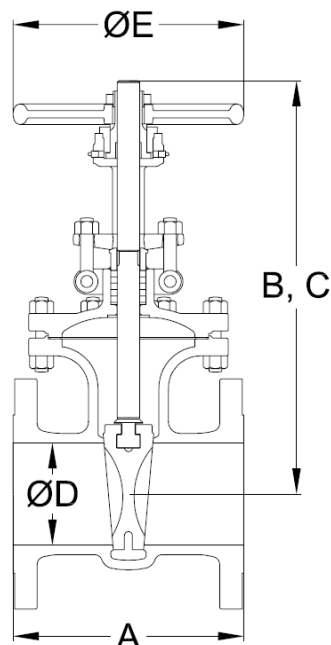

1. Gear operators standard for 16" and up classes 300 and 600. Height is to top of actuator.

- FE = Flanged
- WE = Butt weld
- B = Center to top closed
- C = Center to top open

API 603 GATE VALVES

BOLTED BONNET, ASME CLASSES 150-600

FLANGED OR BUTTWELD ENDS

CAST STAINLESS STEEL

SIZE	ASME 150						ASME 300						ASME 600								
	F	in mm	WT FE	lb kg	WT WE	lb kg	CV	F	in mm	WT FE	lb kg	WT WE	lb kg	CV	F	in mm	WT FE	lb kg	WT WE	lb kg	CV
½	9.5		6.0		4.8		12.6	9.5		7.3		4.6		12.6	9.6		8.3		5.1		12.6
13	241		2.7		2.2			241		3.3		2.1			244		3.8		2.3		
¾	10.3		8.4		6.5		30	10.3		11.2		6.1		30	10.6		15.0		7.1		30
19	262		3.8		2.9			262		5.1		2.8			269		6.8		3.2		
1	11.3		12.5		9.0		55	11.3		15.4		9.1		55	11.5		20.9		10.6		55
25	287		5.7		4.1			287		7.0		4.1			292		9.5		4.8		
1½	14.5		23.9		18.0		130	14.5		33.1		18.0		130	14.8		38.1		21.3		130
38	368		10.8		8.2			368		15.0		8.2			376		17.3		9.7		
2	16.6		29		24.3		240	16.8		37		28		240	19.8		77		57		240
50	421		13		11			426		17		13			502		35		26		
2½	18.3		43		37		390	20.2		50		36		390	25.7		148		126		390
65	464		20		17			514		23		16			653		67		57		
3	20.7		53		48		560	20.9		53		48		560	27.9		174		143		560
80	527		24		22			530		24		22			709		79		65		
4	25.8		86		75		1020	25.9		119		101		1020	33.4		315		251		1020
100	655		39		34			658		54		46			848		143		114		
6	34.1		139		129		2440	34.6		227		174		2440	46.5		677		573		2440
150	867		63		58			878		103		79			1182		307		260		
8	44.1		251		210		4490	46.5		412		379		4490	54.3		1096		942		4340
200	1119		114		95			1180		187		172			1380		497		427		
10	53.6		419		348		7000	56.0		673		617		7000	62.2		1574		1334		6660
250	1362		190		158			1423		305		280			1581		714		605		
12	61.4		551		536		10500	65.0		957		917		10500	71.1		2000		1702		10000
300	1560		250		243			1650		434		416			1806		907		772		
14	66.7		741		732		12800	73.8		1555		1277		12800	76.2		2761		2373		12000
350	1693		336		332			1875		705		579			1935		1252		1076		
16	74.4		975		963		16900	81.8		1949		1663		16900	84.7		3616		3098		15800
400	1889		442		437			2078		884		754			2151		1640		1405		
18	84.7		1433		1299		22500	89.3		4935		2196		21900	91.5		4507		3861		20600
450	2151		650		589			2267		2238		996			2324		2044		1751		
20	94.7		1744		1678		28100	98.1		3380		2745		27300	99.1		4507		4279		25200
500	2414		791		761			2502		1533		1245			2517		2044		1941		
24	112.6		2580		2481		40900	115.8		4911		3958		40000	116.5		7949		7621		36600
600	2859		1170		1125			2942		2227		1795			2960		3605		3457		

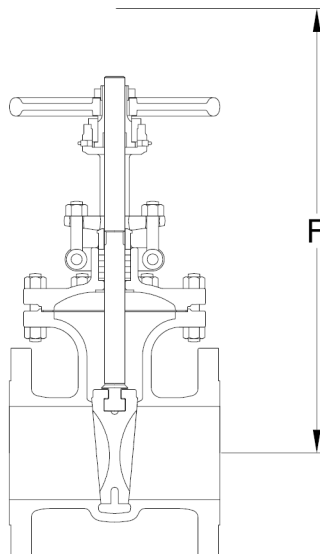

FE = Flanged ends
WE = Weld ends

F = Dismantling Dimension

WT = Weight
C_v = Flow coefficient