

**700E** Wafer with support lugs

**700K** Wafer with support lugs

**700S** Wafer with support lugs



### Features and Benefits

Simple structure and low cost. Many years of proven reliable performance in various industries.

#### Concentric design raised center seat

Figure 1 shows the TOMOE sealing design between the disc and seat. The raised section of the seat reduces and minimises the operating torque while ensuring a tight seal between disc and seat.

#### Rounded dove-tail design

Figure 2 shows the self-gripping seat ring design firmly in place inside the body. This design ensures the seat cannot be displaced during the bolting up of the adjoining flange. The seat also acts as the gasket between the valve and the pipe flange.

#### Triple-sealing system

Figure 3 shows the triple stem seal. The primary seal is created from the initial compression between the flat surface of the seat and the flat hub of the disc. When the valve is subject to normal operating conditions this seals the shaft and body from any contact with the flowing medium. The secondary seal is accomplished by an O-ring fitted into a stainless steel cartridge which is moulded into the seat ring. There is a secondary seal at each end of the stem where it penetrates the seat. The third seal is to prevent dirt and other foreign materials within the environment from getting into any of the working valve parts.

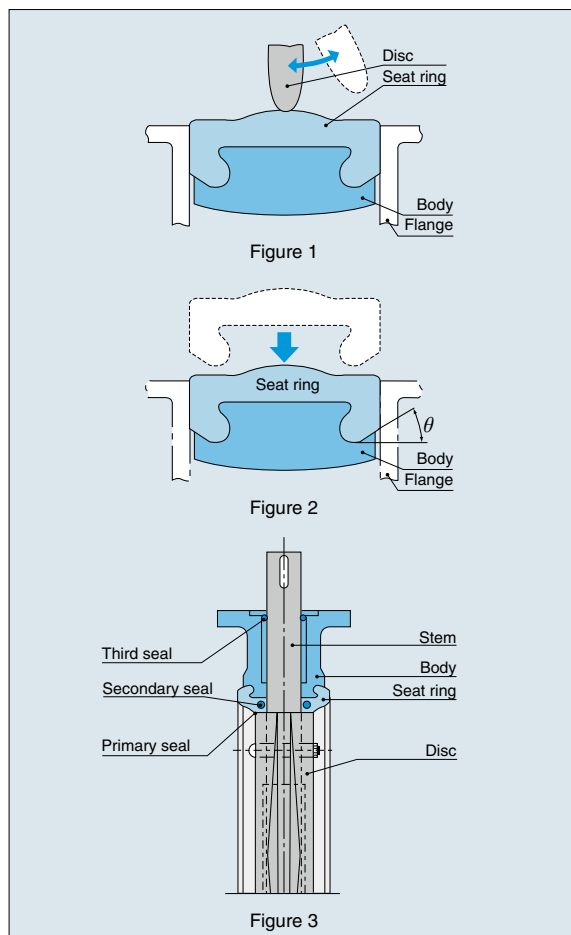

**Discs and seats come in various materials to meet a wide range of needs. These are the ultimate general purpose valves and they provide excellent cost performance.**

### General Description

TOMOE butterfly valves are used worldwide for various applications in water treatment, shipbuilding, air conditioning, petrochemical, power generation and other industries. Among the various types of TOMOE rubber seated butterfly valves, there are three types – 700E, 700K and 700S – that are particularly suitable for large diameter applications.

### Standard Specifications

Type	700E	700K	700S
Size	650mm to 1350mm		
Max. Working Pressure MPa	1.0MPa		
Body shell test	1.5MPa		
Seat leak test	1.1MPa		
Flange standard ※1	JIS 5K/10K	ASME B16.1 Class 125 ISO PN 10 ASME B 16.47 Series A Class 150lb	ASME B16.47 Series B Class 150lb API 605 Class 150
Working temperature range	NBR : -10 to 80 degrees C, *EPDM : -20 to 120 degrees C		
Working temperature in continuous use ※3	NBR : 0 to 60 degrees C, *EPDM : 0 to 70 degrees C		
Standard materials	Body	Cast iron	Cast iron, Ductile iron, Carbon steel
	Disc	Stainless steel Ductile iron with hard Cr plated stainless steel casting Aluminium bronze	
	Stem	Stainless steel, K-MONEL	
	Seat ring ※2	NBR, *EPDM	
Coating	Lacquer Primer (Munsell N7)		

※1 Other flange standards may be available on request. Consult us.

※2 The seat ring of 1000mm and over for 700E/S/K and 720F are vulcanized to the body.

※3 'Working temperature in continuous use' stands for the temperature continuously kept exceeding one hour.

※ Clean face disc (2 shaft design) is available for 700E/S/K and 720F.

※ Please refer to 700G, 704G, 705G in case of 600mm or below.

\* Never use an EPDM rubber seat ring if the valve is being used for oil or for a fluid containing even a slight amount of oil.

# 700E/700K/700S

## 700E / 700K / 700S Expanded View of Component

1000mm to 1350mm

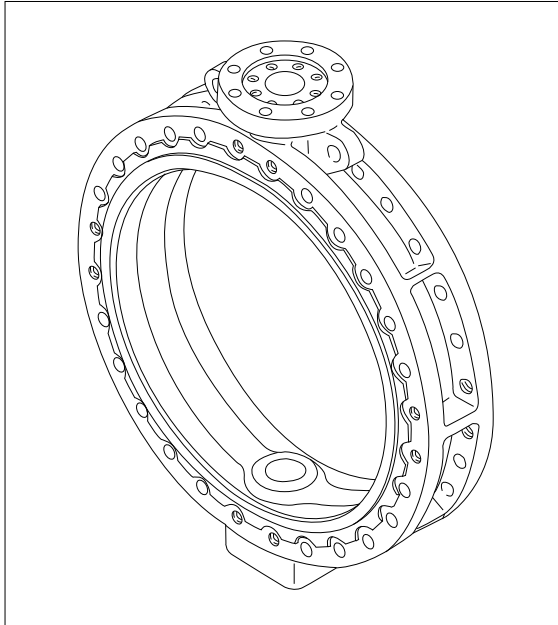

650mm to 1350mm

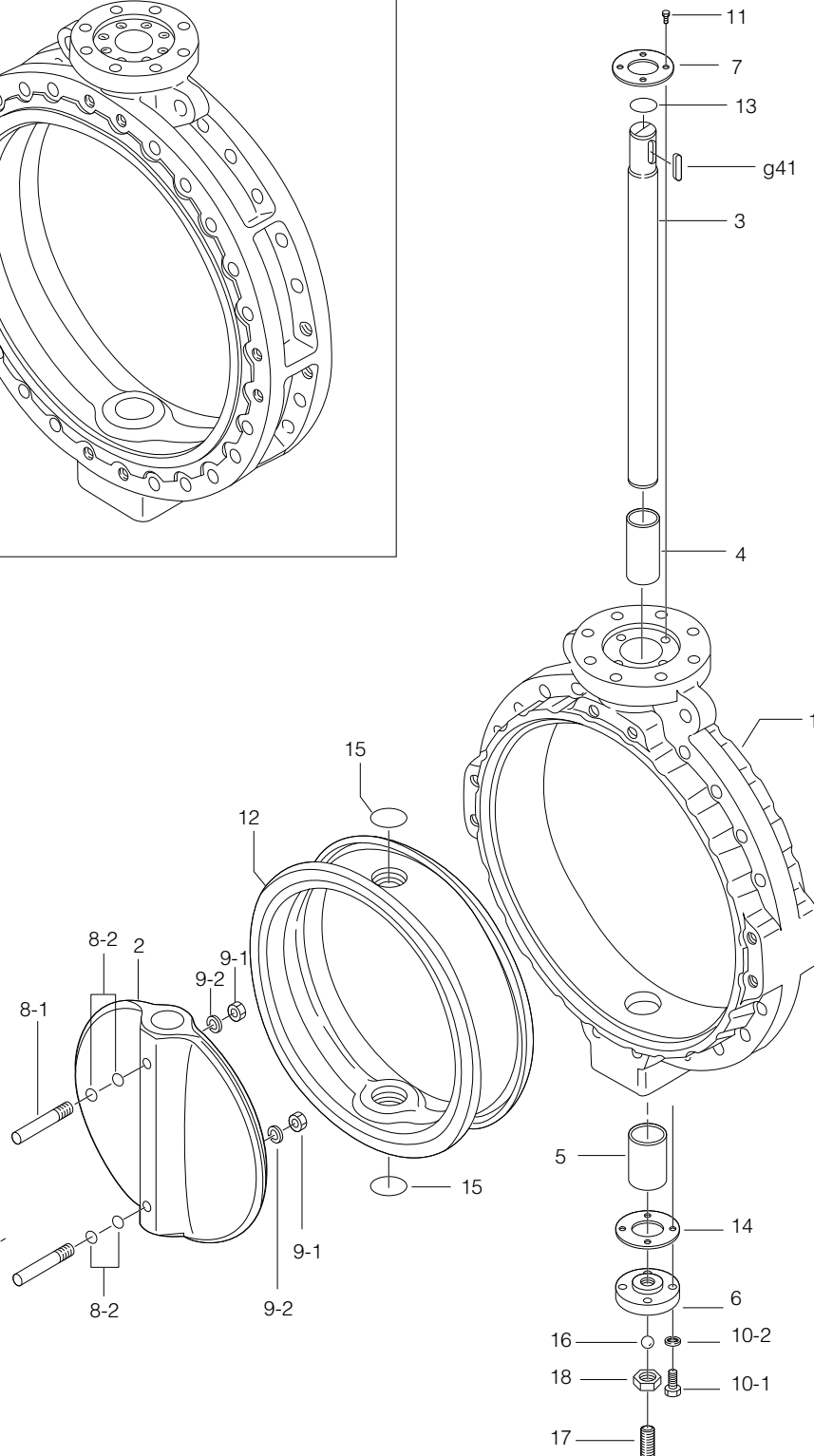

## 700E / 700K / 700S Parts List

### ■ 700E / 700K / 700S Parts List (650mm to 1350mm)

No.	Description	Q'ty	Remarks
1	Body	1	
2	Disc	1	
3	Stem	1	
4	Bushing	1	
5	Bushing	1	
6	Bottom cover	1	
7	Retainer plate	1	
★ 8-1	Taper bolt	2	650mm to 900mm
		4	1000mm to 1350mm
★ 8-2	O-ring	4	650mm to 900mm
		8	1000mm to 1350mm
★ 9-1	Hexagon nut	2	650mm to 900mm
		4	1000mm to 1350mm
★ 9-2	Spring washer	2	650mm to 900mm
		4	1000mm to 1350mm
10-1	Hexagon bolt	4	650mm to 850mm
		8	900mm to 1350mm
10-2	Spring washer	4	650mm to 850mm
		8	900mm to 1350mm
11	Hexagon bolt	4	650mm to 850mm
		8	900mm to 1350mm
★ 12	Seat ring	1	1000mm to 1350mm:Vulcanized to the body
★ 13	O-ring	1	See Remark 2.
14	Gasket	1	
★ 15	O-ring	2	See Remark 2.
16	Ball	1	
17	Hollow bolt	1	
18	Lock nut	1	
g41	Key	1	

Remark 1: The ★ indicates recommended spare parts. They are supplied as "Seat ring set".

Consult us when repairing the seating on 1000 to 1350mm types as it is vulcanized to the body.

Remark 2: The O-ring material (item numbers 13 and 15) should be the same as the seating (item number 12).

# 700E/700K/700S

## 700E / 700K / 700S Actuator Selection Chart

### 700E / 700K / 700S

Model	Category	Size ( $\frac{mm}{inch}$ )									
		650	700	750	800	850	900	1000	1100	1200	1350
		26	28	30	32	34	36	40	44	48	54
2S	Standard	MGH-4	MGH-4 1/2		MGH-5		MGH-6			MGH-7	
	Heavy duty										
3A	Standard	TGA-180	TGA-200	TGA-220	TGA-250						
	Heavy duty	TGA-220		TGA-250							
4L	Standard	LTKD-05 0.75kW /MGH-4	LTKD-05 0.75kW /MGH-5	LTKD-05 1.5kW /MGH-5	LTKD-01 1.5kW /MGH-5		LTKD-01 1.5kW /MGH-6			LTKD-1 2.2kW /MGH-7	
	Heavy duty										

Selection criteria	Standard	Select when none of the following heavy duty items apply.
	Heavy duty	Select when any of the following items apply. ① Powder or high viscosity fluid (crude oil, etc.) ② Control specification (with positioner) ③ Emergency open valve or pipe dead end valve ④ Air or Gas

## 700E / 700K / 700S Pressure-Temperature Rating

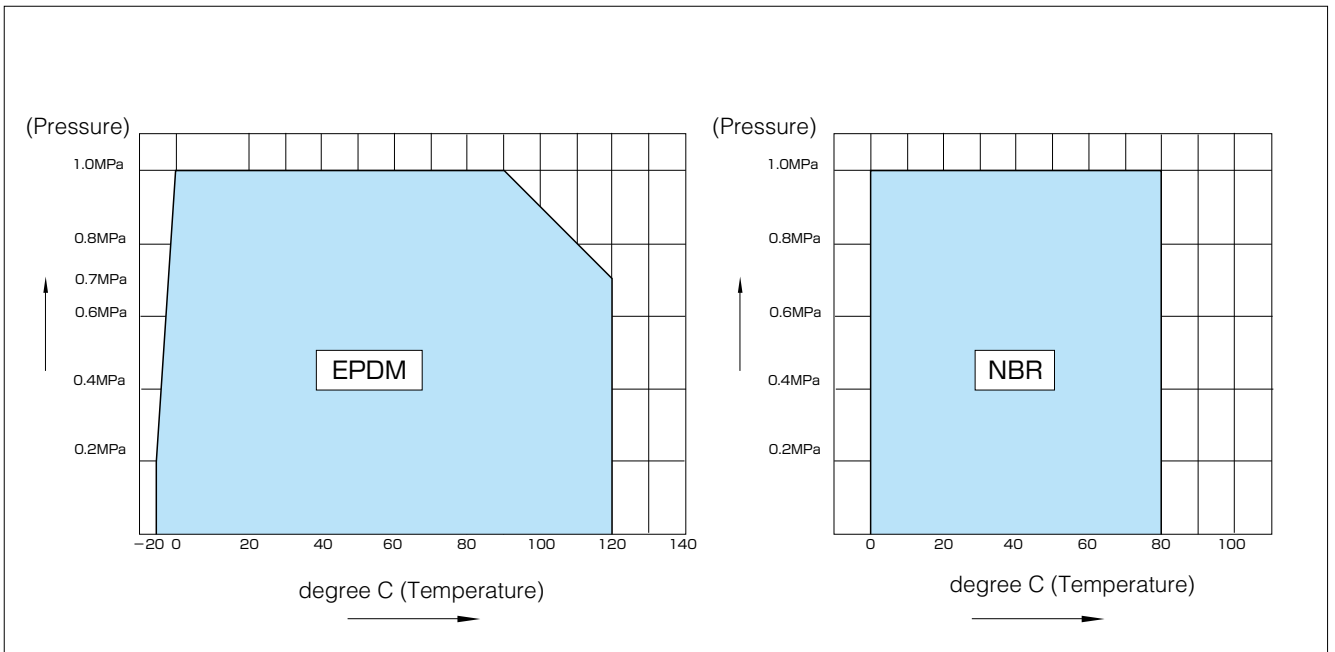

## Wafer with Support Lugs

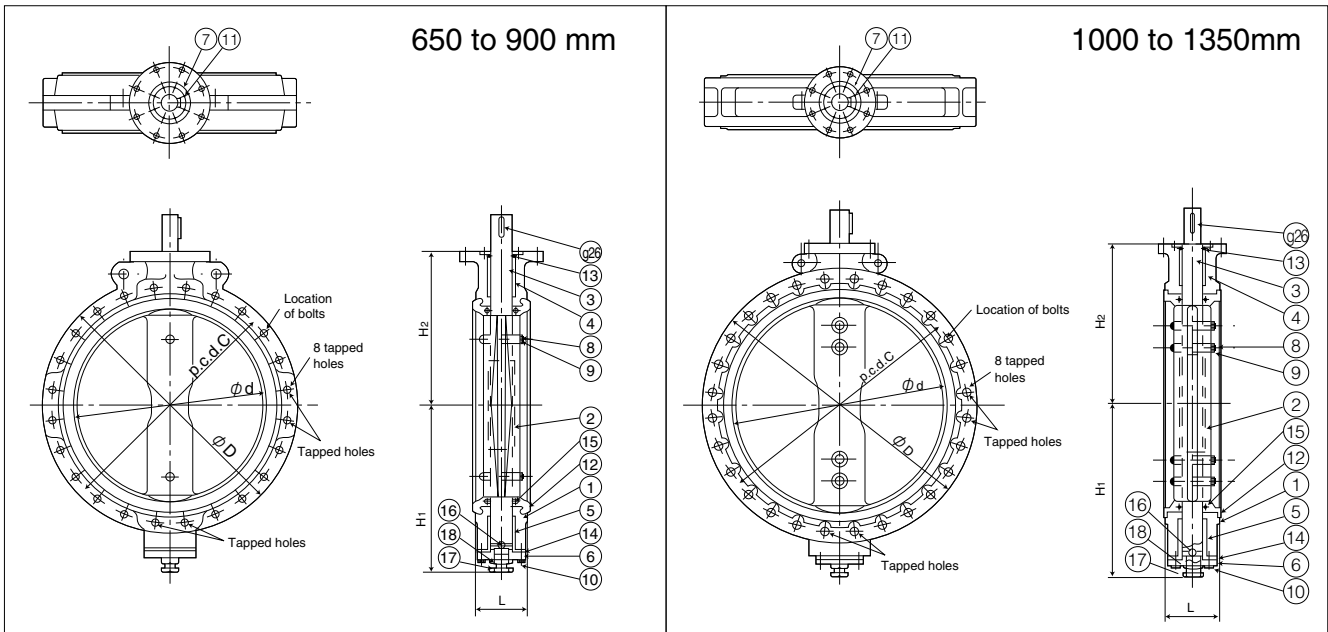

### ■ Dimensions (700E / 700K / 700S)

Nominal size		Dimension (mm)					Weight (kg)	Flange Rating <sup>*1</sup>							
								JIS 5K <sup>*2</sup>		JIS 10K <sup>*2</sup>		ASME B 16.47 Series A		BS 4504 NP10, DIN PN10	
mm	inch	$\phi d$	$\phi D$ <sup>*1</sup>	L	H <sub>1</sub>	H <sub>2</sub>	Long bolts & Nuts	Hex. bolts	Long bolts & Nuts	Hex. bolts	Long bolts & Nuts	Hex. bolts	Long bolts & Nuts	Hex. bolts	
650	26	627	845	170	558	510	360	16-M24×285×50	16-M24×65×54	16-M30×310×60	16-M30×80×66	16-U1 1/4×390×70	16-U1 1/4×110×70	16-M20×200×45	—
700	28	670	905	180	629	560	490	16-M24×295×50	16-M24×65×54	16-M30×320×60	16-M30×80×66	20-U1 1/4×410×70	16-U1 1/4×110×70	16-M24×210×50	—
750	30	723	970	190	659	590	540	16-M30×320×60	16-M30×75×66	16-M30×335×60	16-M30×80×66	20-U1 1/4×425×70	16-U1 1/4×125×70	20-M24×250×50	—
800	32	772	1020	200	679	620	710	16-M30×335×60	16-M30×75×66	20-M30×345×60	16-M30×80×66	20-U1 1/2×460×80	16-U1 1/4×125×70	16-M27×280×60	8-M27×60×50
850	34	822	1070	210	709	650	800	16-M30×345×60	16-M30×75×66	20-M30×360×60	16-M30×80×66	24-U1 1/2×475×80	16-U1 1/4×135×80	16-M27×305×60	16-M27×65×54
900	36	858	1120	230	759	685	870	16-M30×360×60	16-M30×75×66	20-M30×385×65	16-M30×85×66	24-U1 1/2×510×80	16-U1 1/4×145×80	16-M30×335×60	16-M30×65×54
1000	40	975	1235	250	819	745	1200	20-M30×385×65	16-M30×85×66	20-M36×420×75	16-M36×100×78	28-U1 1/2×530×80	16-U1 1/4×145×80	20-M30×370×65	16-M30×75×66
1100	44	1070	1345	280	874	820	1350	20-M30×420×65	16-M30×85×66	20-M36×450×80	16-M36×100×78	32-U1 1/2×580×80	16-U1 1/4×155×80	20-M33×400×65	16-M33×90×72
1200	48	1168	1465	300	949	880	1700	24-M30×445×65	16-M30×85×66	24-M36×475×80	16-M36×100×78	36-U1 1/2×615×80	16-U1 1/4×160×80	24-M36×475×80	16-M36×100×78
1350	54	1314	1630	330	1030	960	2300	24-M30×475×65	16-M30×85×66	28-M42×525×80	16-M42×100×90	—	—	—	—

\*700S dimensions for ASME B16-47, series B class finish are available upon request.

\*1 "D" dimension shows for 700E, JIS 10 K.

\*2 Nut is 80% of bolt diameter.

# 700E/700K/700S

## Worm Gear Type 700E / 700K / 700S-2S (650mm to 1350mm)

### 700E / 700K / 700S-2S

Nominal size		Dimension (mm)										Gear type	Approx. Weight (kg)
mm	inch	$\phi d$	$\phi D$	L	H <sub>1</sub>	H <sub>2</sub>	H <sub>3</sub>	E	K	F	W		
650	26	627	845	170	558	510	65	140	198	400	450	MGH-4	363
700	28	670	905	180	629	560	75	185	267	457	500	MGH-41/2	487
750	30	723	970	190	659	590	75	185	267	457	500	MGH-41/2	547
800	32	772	1020	200	679	620	75	185	267	457	500	MGH-41/2	617
850	34	822	1070	210	709	650	100	210	293	490	500	MGH-5	780
900	36	858	1120	230	759	685	100	210	293	490	500	MGH-5	855
1000	40	975	1235	250	819	745	100	210	293	490	500	MGH-6	1384
1100	44	1070	1345	280	874	820	100	210	293	490	500	MGH-6	1584
1200	48	1170	1465	300	948	880	100	210	293	490	500	MGH-6	1984
1350	54	1314	1630	330	1030	960	151	280	293	675	600	MGH-7	2330

### 700E / 700K / 700S-2S

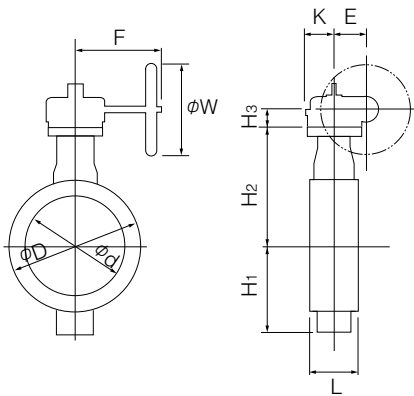

### 2S Installation Direction

2SA (standard)	2SAR
2SB	2SBR

## Double-acting Pneumatic Cylinder Type 700E / 700K / 700S-3A (650mm to 900mm)

### Standard

Nominal size		Dimension (mm)										Cylinder type	Approx. Weight (kg)
mm	inch	$\phi d$	$\phi D$	L	H <sub>1</sub>	H <sub>2</sub>	H <sub>3</sub>	A	P	f <sub>1</sub>	f <sub>2</sub>		
650	26	627	845	170	558	510	478	1053	543	130	218	TGA-180	456
700	28	670	905	180	629	560	570	1163	599	160	253	TGA-200	607
750	30	723	970	190	659	590	570	1163	599	160	253	TGA-200	667
800	32	772	1020	200	679	620	600	1248	642	160	270	TGA-220	761
850	34	822	1070	210	709	650	600	1248	642	160	270	TGA-220	881
900	36	858	1120	230	759	685	633	1381	707	160	299	TGA-250	1022

### Heavy Duty

Nominal size		Dimension (mm)										Cylinder type	Approx. Weight (kg)
mm	inch	$\phi d$	$\phi D$	L	H <sub>1</sub>	H <sub>2</sub>	H <sub>3</sub>	A	P	f <sub>1</sub>	f <sub>2</sub>		
650	26	627	845	170	558	510	600	1248	642	160	270	TGA-220	562
700	28	670	905	180	629	560	600	1248	642	160	270	TGA-220	637
750	30	723	970	190	659	590	633	1381	707	160	299	TGA-250	756
800	32	772	1020	200	679	620	633	1381	707	160	299	TGA-250	826

Selection criteria	Standard	Select when none of the following heavy duty items apply.
	Heavy duty	Select when any of the following items apply. ① Powder or high viscosity fluid (crude oil, etc.) ② Control specification (with positioner) ③ Emergency open valve or pipe dead end valve ④ Air or Gas

### 700E / 700K / 700S-3A

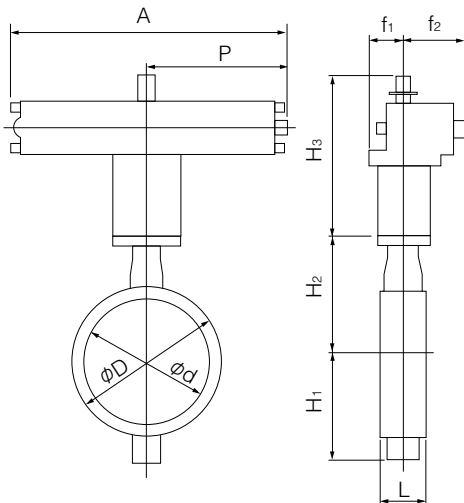

### 3A Installation Direction

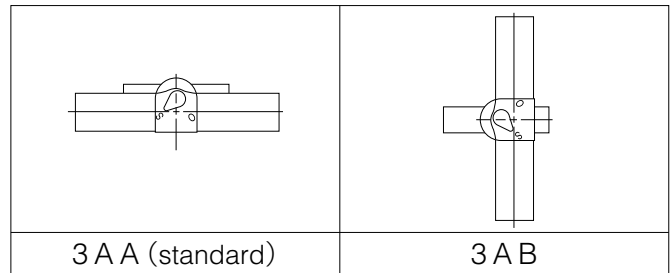



# 700E/700K/700S

## Three Phase Motor Actuator Type 700E / 700K / 700S-4L (650mm to 1350mm)

Nominal size		Dimension (mm)											Motor type	Approx. Weight (kg)
mm	inch	$\phi d$	$\phi D$	L	H <sub>1</sub>	H <sub>2</sub>	H <sub>3</sub>	E	K	F	M	P		
650	26	627	845	170	558	510	570	140	198	637	440	375	LTKD-05 0.75kW /MGH-4	515
700	28	670	905	180	629	560	640	210	293	747	440	375	LTKD-05 0.75kW /MGH-5	710
750	30	723	970	190	659	590	640	210	293	747	477	375	LTKD-05 1.5kW /MGH-5	770
800	32	772	1020	200	679	620	680	210	293	797	537	425	LTKD-1 1.5kW /MGH-5	905
850	34	822	1070	210	709	650	680	210	293	797	537	425	LTKD-1 1.5kW /MGH-5	1025
900	36	858	1120	230	759	685	680	210	293	797	537	425	LTKD-1 1.5kW /MGH-5	1100
1000	40	975	1235	250	819	745	700	210	293	762	537	425	LTKD-1 1.5kW /MGH-6	1670
1100	44	1070	1345	280	874	820	700	210	293	762	537	425	LTKD-1 1.5kW /MGH-6	1870
1200	48	1170	1465	300	948	880	700	210	293	762	537	425	LTKD-1 1.5kW /MGH-6	2270
1350	54	1314	1630	330	1030	960	700	280	293	810	540	410	LTKD-1 2.2kW /MGH-7	2650

### 700E / 700K / 700S-4L

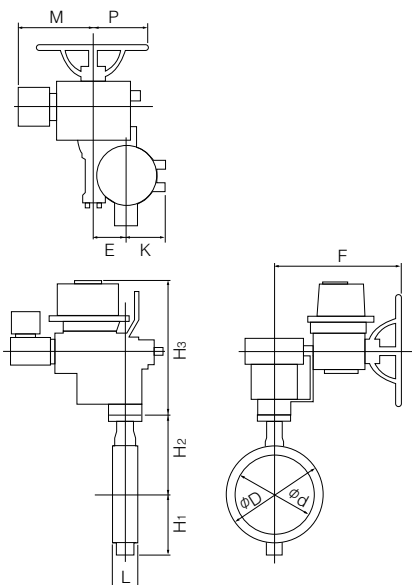

### 4L Installation Direction

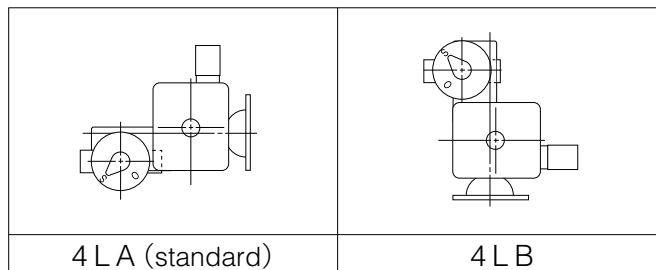

## 700E / 700K / 700S Cv Value/Pressure Loss Coefficient

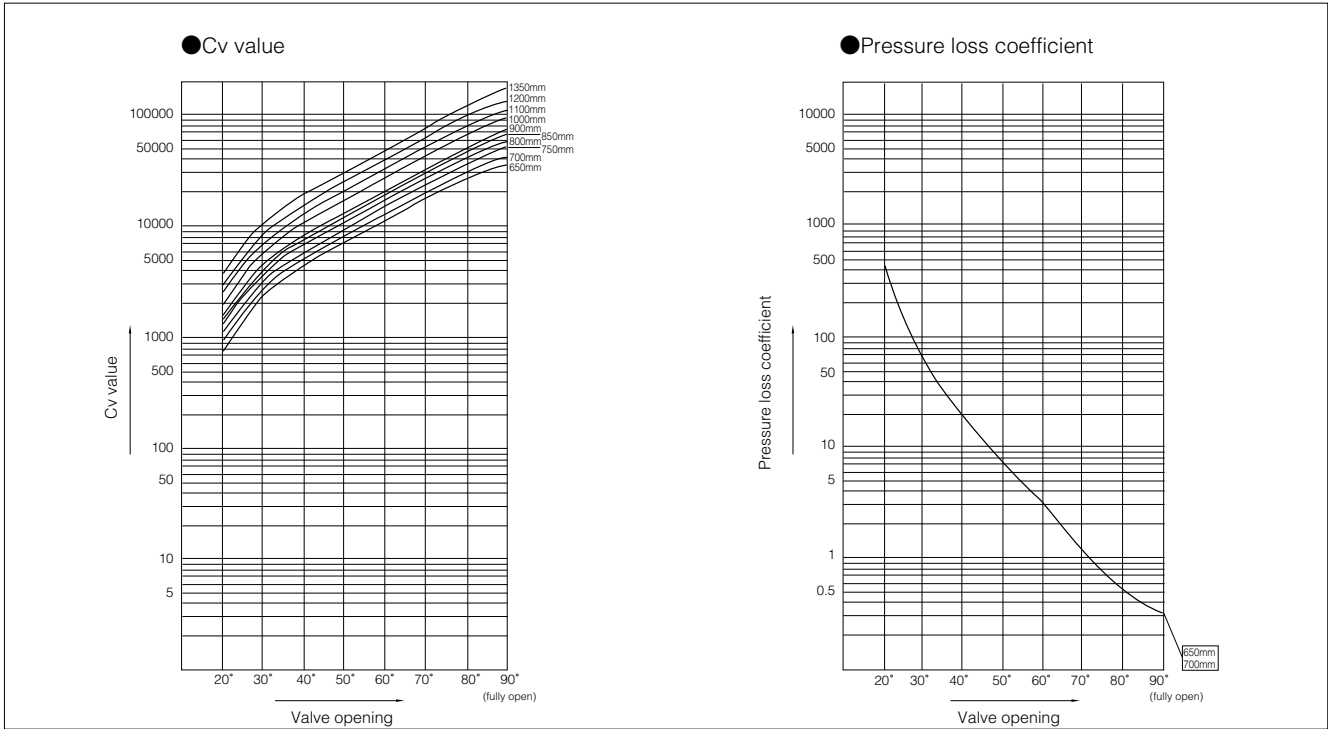

### 700E / 700K / 700S Cv Value

Nominal size		Valve opening							
		20°	30°	40°	50°	60°	70°	80°	90°
650	26	817	2441	4473	7159	11013	17254	26972	32500
700	28	934	2807	5122	8152	12511	19728	30929	39000
750	30	935	3220	5965	9450	14328	22687	38260	52000
800	32	1200	3721	6791	10771	16553	26976	43316	59000
850	34	1164	4018	7516	12063	18567	29284	46350	66000
900	36	1358	4497	8298	13177	20139	32362	53126	73000
1000	40	1784	5835	10740	17060	26110	42070	68860	95000
1100	44	2075	7030	13020	20680	31530	50420	83340	114000
1200	48	2570	8520	15710	24900	37930	60280	98640	138000
1350	54	3385	10180	18810	30490	47840	75750	119000	173000

### 700E / 700K / 700S Pressure Loss Coefficient

Nominal size		Valve opening							
		20°	30°	40°	50°	60°	70°	80°	90°
650	26	553	62	18	7	3	1	1	0.4
700	28	573	63	19	8	3	1	1	0.3
750	30	758	64	19	7	3	1	0.5	0.3
800	32	599	62	19	7	3	1	0.5	0.3
850	34	815	68	20	8	3	1	0.5	0.3
900	36	756	69	20	8	3	1	0.5	0.3
1000	40	645	60	18	7	3	1	0.4	0.2
1100	44	701	61	18	7	3	1	0.4	0.2
1200	48	658	60	18	7	3	1	0.4	0.2
1350	54	611	68	20	8	3	1	0.5	0.2

# 700E/700K/700S

## 700E / 700K / 700S Applicable Flange Standard

Nominal size		JIS			ANSI		BS4504	DIN	BS10
mm	inch	5K	10K	G5527	125Lb	150Lb	PN10	NP10	Table E
650	26	T	T	Consult us if flange standard is not JIS 5K/10K.					
700	28	T	T						
750	30	T	T						
800	32	T	T						
850	34	T	T						
900	36	T	T						
1000	40	T	T						
1100	44	T	T						
1200	48	T	T						
1350	54	T	T						

○ : Can be used without flange drilling.  
 D/T : With drill hole or tapping.  
 T : With flange tapping.  
 - : No nominal diameter.

## 700E / 700K / 700S Applicable Pipe List in Case of **A**

Nominal size		STPY	Sch20	Sch40	Minimum internal diameter of piping (mm)
mm	inch				
650	26	○	○	○	612
700	28	○	-	-	653
750	30	○	-	-	705
800	32	○	-	-	754
850	34	○	-	-	803
900	36	○	-	-	834
1000	40	○	-	-	950
1100	44	○	-	-	1040
1200	48	○	-	-	1138
1350	54	○	-	-	1277

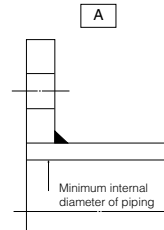

Remark 1: ○=Applicable  
 Remark 2: Butterfly valves are inserted into a pipe that was fitted with the disc when fully open.  
 In cases where you are using a pipe or flange that is less than the minimum inner pipe diameter, use is still possible if means are taken such as inserting a spacer between the valve and flange.  
 For details, please consult us.

## 700E / 700K / 700S Applicable Pipe List in Case of **B**

Nominal size		STPY	Sch20	Sch40
mm	inch			
650	26	○	○	○
700	28	○	-	-
750	30	○	-	-
800	32	○	-	-
850	34	○	-	-
900	36	○	-	-
1000	40	○	-	-
1100	44	○	-	-
1200	48	○	-	-
1350	54	○	-	-

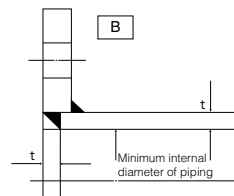

Remark 1: ○=Applicable  
 Remark 2: Butterfly valves are inserted into a pipe that was fitted with the disc when fully open.  
 In cases where you are using a pipe or flange that is less than the minimum inner pipe diameter, use is still possible if means are taken such as inserting a spacer between the valve and flange.  
 For details, please consult us.

# MEMO
