

BELLOWS SEAL GATE VALVES – BOLTED / WELDED BONNET – REDUCED / FULL PORT

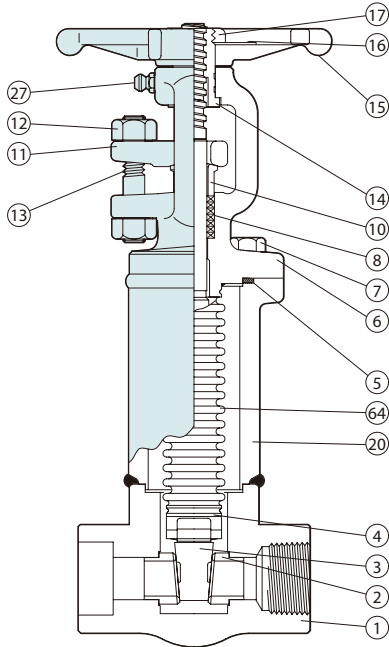

NO.	Parts	Material	A.S.T.M
1	Body	Forged Steel	A105N
2	Seat Ring	Stellite 6 faced A276-316	
3	Wedge	Stellite 6 faced A351-CF8M	
4	Stem	Stainless Steel	A276-316
5	Gasket	304 Spiral Wound Graphite	
6	Bonnet	Forged Steel	A105N
7	Bonnet Bolt	Alloy Steel	A193-B7M
8	Gland Packing	Graphoil	
10	Gland	Stainless Steel	A276-316
11	Gland Flange	Forged Steel	A105
12	Gland Nut	Carbon Steel	A194-2H
13	Gland Bolt	Stainless Steel	A193-B6
14	Yoke Sleeve	13Cr Stainless Steel	A582-416
15	Handwheel	Malleable Iron	A47
16	Name Plate	Aluminum	
17	Handwheel Nut	Carbon Steel	A563A
20	Connector	Forged Steel	A105N
27	Grease Nipple	Cr Plated Carbon Steel	
64	Bellows	321 Stainless Steel or Inconel 625	

CLASS 600 / 800 - API 602 / ASME B16.34

Unit : mm(inch)

Port	Valve Size	Handwheel Diameter	End to End	Center to Top (Open)	Dia. of Port Openings	Weight Kg(Lb)
Reduced	1/2	86 (3.39)	76 (2.99)	210 (8.27)	9.8 (0.39)	2.4 (5.3)
	3/4	86 (3.39)	86 (3.39)	227 (8.94)	13.0 (0.51)	3.1 (6.8)
	1	99 (3.90)	102 (4.02)	306 (12.05)	18.0 (0.71)	4.0 (8.8)
	1 1/4	124 (4.88)	117 (4.61)	400 (15.75)	31.0 (1.22)	8.1 (17.9)
	1 1/2	124 (4.88)	117 (4.61)	400 (15.75)	31.0 (1.22)	8.1 (17.9)
	2	138 (5.43)	133 (5.24)	500 (19.69)	37.0 (1.46)	12.9 (28.5)
Full	1/2	86 (3.39)	86 (3.39)	227 (8.94)	13.0 (0.51)	3.1 (6.8)
	3/4	99 (3.90)	102 (4.02)	306 (12.05)	18.0 (0.71)	4.0 (8.8)
	1	124 (4.88)	117 (4.61)	400 (15.75)	23.0 (0.91)	8.1 (17.9)
	1 1/4	138 (5.43)	133 (5.24)	500 (19.69)	37.0 (1.46)	12.9 (28.5)
	1 1/2	138 (5.43)	133 (5.24)	500 (19.69)	37.0 (1.46)	12.9 (28.5)
	2	157 (6.18)	218 (8.58)	610 (24.02)	50.8 (2.00)	18.5 (40.8)

CLASS 1500 - API 602 / ASME B16.34

Unit : mm(inch)

Port	Valve Size	Handwheel Diameter	End to End	Center to Top (Open)	Dia. of Port Openings	Weight Kg(Lb)
Reduced	1/2	157 (6.18)	86 (3.39)	316 (12.44)	9.8 (0.39)	4.0 (8.8)
	3/4	157 (6.18)	102 (4.02)	348 (13.70)	13.0 (0.51)	5.5 (12.1)
	1	157 (6.18)	117 (4.61)	410 (16.14)	18.0 (0.71)	9.0 (19.9)
	1 1/4	200 (7.87)	133 (5.24)	550 (21.65)	31.0 (1.22)	16.0 (35.3)
	1 1/2	200 (7.87)	133 (5.24)	550 (21.65)	31.0 (1.22)	16.0 (35.3)
	2	230 (9.06)	210 (8.27)	620 (24.41)	37.0 (1.46)	20.0 (44.1)

BELLOWS SEAL GATE VALVES – BOLTED / WELDED BONNET – REDUCED PORT

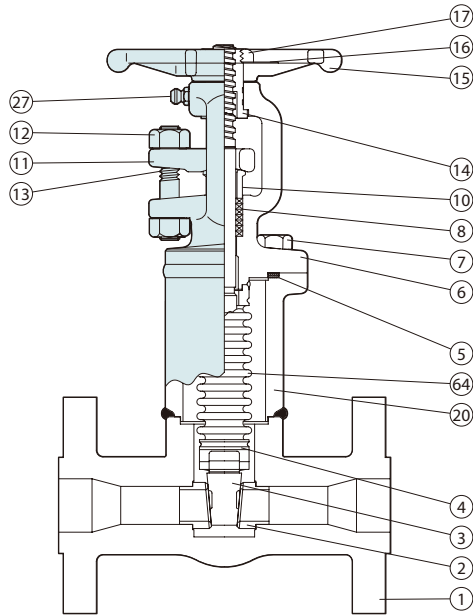

NO.	Parts	Material	A.S.T.M
1	Body	Forged Steel	A105N
2	Seat Ring	Stellite 6 faced A276-316	
3	Wedge	Stellite 6 faced A351-CF8M	
4	Stem	Stainless Steel	A276-316
5	Gasket	304 Spiral Wound Graphite	
6	Bonnet	Forged Steel	A105N
7	Bonnet Bolt	Alloy Steel	A193-B7M
8	Gland Packing	Graphoil	
10	Gland	Stainless Steel	A276-316
11	Gland Flange	Forged Steel	A105
12	Gland Nut	Carbon Steel	A194-2H
13	Gland Bolt	Stainless Steel	A193-B6
14	Yoke Sleeve	13Cr Stainless Steel	A582-416
15	Handwheel	Malleable Iron	A47
16	Name Plate	Aluminum	
17	Handwheel Nut	Carbon Steel	A563A
20	Connector	Forged Steel	A105N
27	Grease Nipple	Cr Plated Carbon Steel	
64	Bellows	321 Stainless Steel or Inconel 625	

CLASS 150 / 300 / 600 - API 602 / ASME B16.34

Unit : mm(inch)

Port	Valve Size	Handwheel Diameter	Center to Top (Open)	Dia. of Port Openings	Face to Face			Weight Kg(Lb)		
					Class 150	Class 300	Class 600	Class 150	Class 300	Class 600
Reduced	1/2	86 (3.39)	210 (8.27)	9.8 (0.39)	108 (4.25)	140 (5.50)	165 (6.50)	3.4 (7.5)	3.9 (8.6)	4.2 (9.3)
	3/4	86 (3.39)	227 (8.94)	13.0 (0.51)	117 (4.62)	152 (6.00)	190 (7.50)	4.2 (9.3)	5.1 (11.3)	5.7 (12.6)
	1	99 (3.90)	306 (12.05)	18.0 (0.71)	127 (5.00)	165 (6.50)	216 (8.50)	5.9 (13.0)	7.2 (15.9)	7.8 (17.2)
	1 1/2	124 (4.88)	400 (15.75)	31.0 (1.22)	165 (6.50)	190 (7.50)	241 (9.50)	11.6 (25.6)	13.9 (30.7)	15.1 (33.3)
	2	138 (5.43)	500 (19.69)	37.0 (1.46)	178 (7.00)	216 (8.50)	292 (11.50)	16.9 (37.3)	18.7 (41.2)	20.5 (45.2)

CLASS 1500 - API 602 / ASME B16.34

Unit : mm(inch)

Port	Valve Size	Handwheel Diameter	Center to Top (Open)	Dia. of Port Openings	Face of Face	Weight Kg(Lb)
Reduced	1/2	157 (6.18)	316 (12.44)	9.8 (0.39)	216 (8.50)	8.5 (18.7)
	3/4	157 (6.18)	348 (13.70)	13.0 (0.51)	229 (9.00)	11.1 (24.5)
	1	157 (6.18)	410 (16.14)	18.0 (0.71)	254 (10.00)	17.0 (37.5)
	1 1/2	200 (7.87)	550 (21.65)	31.0 (1.22)	305 (12.00)	29.7 (65.5)
	2	200 (7.87)	620 (24.41)	37.0 (1.46)	368 (14.25)	41.5 (91.5)

BELLOWS SEAL GATE VALVES – BOLTED / WELDED BONNET – REDUCED PORT

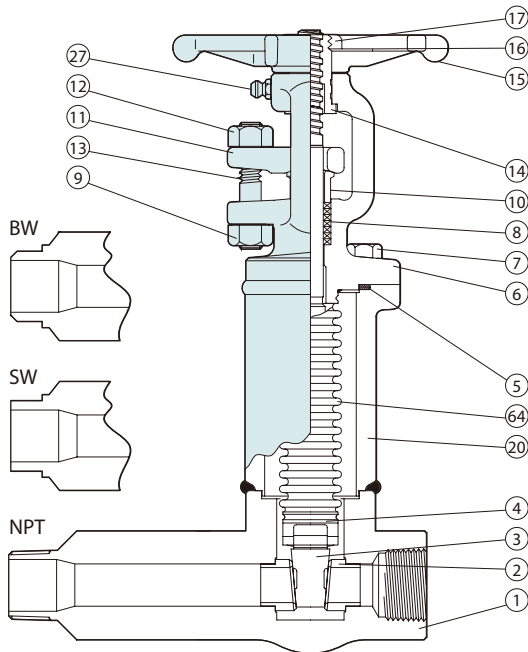

NO.	Parts	Material	A.S.T.M
1	Body	Forged Steel	A105N
2	Seat Ring	Stellite 6 faced A276-316	
3	Wedge	Stellite 6 faced A351-CF8M	
4	Stem	Stainless Steel	A276-316
5	Gasket	304 Spiral Wound Graphite	
6	Bonnet	Forged Steel	A105N
7	Bonnet Bolt	Alloy Steel	A193-B7M
8	Gland Packing	Graphoil	
10	Gland	Stainless Steel	A276-316
11	Gland Flange	Forged Steel	A105
12	Gland Nut	Carbon Steel	A194-2H
13	Gland Bolt	Stainless Steel	A193-B6
14	Yoke Sleeve	13Cr Stainless Steel	A582-416
15	Handwheel	Malleable Iron	A47
16	Name Plate	Aluminum	
17	Handwheel Nut	Carbon Steel	A563A
20	Connector	Forged Steel	A105N
27	Grease Nipple	Cr Plated Carbon Steel	
64	Bellows	321 Stainless Steel or Inconel 625	

CLASS 800 - API 602 / ASME B16.34

Unit : mm(inch)

Port	Valve Size	Handwheel Diameter	End to End	Center to Male End	Center to Top (Open)	Dia. of Port Openings	Weight Kg(Lb)
Reduced	1/2	86 (3.39)	142 (5.59)	104 (4.10)	210 (8.27)	9.8 (0.39)	2.5 (5.5)
	3/4	86 (3.39)	157 (6.18)	114 (4.49)	227 (8.94)	13.0 (0.51)	4.8 (10.6)
	1	99 (3.90)	165 (6.50)	114 (4.49)	306 (12.05)	18.0 (0.71)	8.8 (19.4)
	1 1/2	124 (4.88)	193 (7.60)	135 (5.32)	400 (15.75)	31.0 (1.22)	11.8 (26.0)
	2	138 (5.43)	212 (8.35)	146 (5.75)	500 (19.69)	37.0 (1.46)	15.0 (33.1)

CLASS 1500 - API 602 / ASME B16.34

Unit : mm(inch)

Port	Valve Size	Handwheel Diameter	End to End	Center to Male End	Center to Top (Open)	Dia. of Port Openings	Weight Kg(Lb)
Reduced	1/2	157 (6.18)	157 (6.18)	114 (4.49)	316 (12.44)	9.8 (0.39)	4.8 (10.6)
	3/4	157 (6.18)	165 (6.50)	114 (4.49)	348 (13.70)	13.0 (0.51)	8.2 (18.1)
	1	157 (6.18)	193 (7.60)	135 (5.32)	410 (16.14)	18.0 (0.71)	11.2 (24.7)
	1 1/2	200 (7.87)	212 (8.35)	146 (5.75)	550 (21.65)	31.0 (1.22)	15.0 (33.1)