

Bronze Ball Valves

Two-Piece Body • 250 Steam Rating • Full Port • 316SS Trim • Carbon-Filled PTFE Seats • Blowout-Proof Stem • Vented Ball

600 PSI/41.4 bar non-shock cold working pressure
250 PSI/17.2 bar saturated steam*

CONFORMS TO MSS SP-110

MATERIAL LIST

PART	SPECIFICATION
1. Handle Nut	300 Series Stainless Steel
2. Handle	Stainless Steel Plastisol Coated
3. Threaded Pack Gland	Brass ASTM B 16 Alloy C36000
4. Packing	Carbon Filled PTFE
5. Thrust Washer	Carbon Filled PTFE
6. Stem	Stainless Steel ASTM A 276 Type 316
7. Ball (Vented)	Stainless Steel ASTM A 276 Type 316 or ASTM A 351 Type CF8M
8. Seat Ring (2)	Carbon Filled PTFE
9. Body	Bronze ASTM B 61 Alloy C92200
10. Body End Piece	Bronze ASTM B 584 Alloy C84400



T-585-70-66-ST
Threaded

DIMENSIONS—WEIGHTS—QUANTITIES

Size	Dimensions					T-585-70-66-ST		Master Ctn. Qty.
	A	B	C	D	Lbs.	Kg.		
In. mm.	In. mm.	In. mm.	In. mm.	In. mm.				
½ 15	2.44 62	1.88 48	5.19 132	.50 13	.64	.29	10	
¾ 20	2.94 75	2.25 57	6.25 159	.75 19	1.33	.60	5	
1 25	3.34 85	2.38 61	6.44 164	1.00 25	1.79	.81	5	
1¼ 32	4.19 106	3.00 76	6.75 171	1.25 32	2.17	.98	5	
1½ 40	4.72 120	3.16 80	9.06 230	1.50 38	3.27	1.48	5	
2 50	5.16 131	3.50 89	9.25 235	2.00 51	5.09	2.31	2	

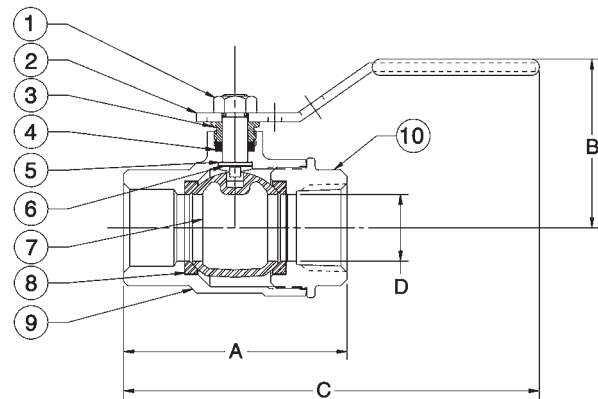

T-585-70-66-ST
NPT x NPT

*For detailed operating pressure, refer to pressure temperature chart on page 42.



WARNING: This product can expose you to chemicals including lead, which is known to the State of California to cause cancer and birth defects or other reproductive harm. For more information go to www.P65Warnings.ca.gov.

Visit our website for the most current information.