

Carbon Steel Ball Valves

One-Piece Body • Reduced Port • Blowout-Proof Stem •
316 SS Trim • Vented Ball • Fire Safe

2000 PSI/138 bar non-shock cold working pressure*

CONFORMS TO API-607 FOURTH EDITION FIRE SAFE
MSS SP-110

MATERIAL LIST

PART	SPECIFICATION
1. Body	Carbon Steel ASTM A 216 Grade WCB
2. Body Insert	Carbon Steel ASTM A 216 Grade WCB
3. Ball (Vented)	Stainless Steel ASTM A 276 Type 316 or ASTM A 351 Type CF8M
4. Stem	Stainless Steel ASTM A 276 Type 316
5. Seat	Reinforced PTFE
6. Thrust Washer	Carbon Filled PTFE
7. ¹ Stem Packing	Graphoil
8. Threaded Pack Gland	Carbon Steel ASTM A 108 Type 1045
9. Handle Nut	Carbon Steel ASTM A 283
10. Handle	Carbon Steel ASTM A 283

¹ 1/2"-3/4" one each, 1"-2" two each.

NOTE: valves are static grounded by thrust washer and packing.



T-560-CS-R-66-FS-LL

Threaded

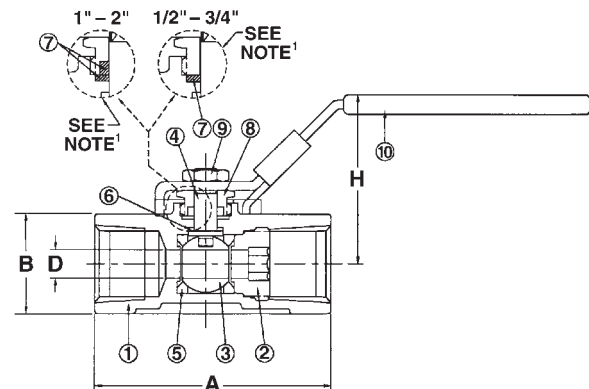
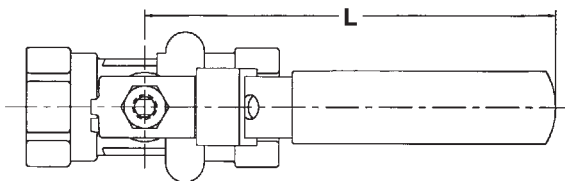

T-560-CS-R-66-FS-LL

NPT x NPT

DIMENSIONS—WEIGHTS—QUANTITIES

Size	Dimensions						T-560-CS-R-66-FS-LL		Master Ctn. Qty.
	A	B	D	L	H	Lbs.	Kg.		
In. mm.	In. mm.	In. mm.	In. mm.	In. mm.	In. mm.				
1/2 15	2.60 66	1.10 28	.31 8	4.29 109	1.97 50	.66	.30	50	
3/4 20	2.83 72	1.34 34	.47 12	4.29 109	2.20 56	.93	.42	50	
1 25	3.23 82	1.61 41	.62 16	5.75 146	2.56 65	1.59	.72	40	
1 1/4 32	3.54 90	1.97 50	.81 21	5.75 146	2.76 70	2.22	1.01	20	
1 1/2 40	3.86 98	2.24 57	1.00 25	7.40 188	3.29 84	3.22	1.46	20	
2 50	4.33 110	2.76 70	1.25 32	7.40 188	3.49 89	4.65	2.11	10	

◆ For detailed operating pressure, refer to pressure temperature chart on pages 71 and 72.

Visit our website for the most current information.