

NIBCO® Press System Bronze In-line Lift Check Valves

In-Line Lift Type • Resilient Discs • Spring Actuated

200 psi/17.2 bar non-shock cold working pressure
250°F maximum operating temperature

Dezincification
Resistant

MATERIAL LIST

PART	SPECIFICATION
1. Body	Bronze ASTM B584 Alloy C84400
2. Stem	Stainless Steel ASTM A582 Alloy C30300
3. Spring	316 Stainless Steel
4. Disc Holder	Stainless Steel Type 301
5. Disc	PTFE
6. Seat Screw	Stainless Steel ASTM A276 Alloy S43000
7. Body End	Bronze ASTM B584 Alloy C84400
8. Adapter (2)	Bronze ASTM B61 Alloy C92200
9. O-Ring (2)	EPDM



PF-480-Y

Press x Press
Female End

DIMENSIONS—WEIGHTS

Size	Dimensions						Weight		
	A		B		C		Lbs.	Kg.	
In.	mm.	In.	mm.	In.	mm.	In.	mm.		
½	15	2.41	61	1.38	35	.50	13	0.52	0.24
¾	20	3.05	77	1.63	41	.75	19	0.75	0.34
1	25	3.56	90	2.00	51	1.00	25	1.18	0.54
1¼	32	3.86	98	2.38	60	1.25	32	1.72	0.78
1½	40	4.45	113	2.75	70	1.50	38	2.49	1.13
2	50	5.28	134	3.38	86	2.00	51	3.96	1.80

NIBCO Press System check valves may be installed in both horizontal and vertical lines with upward flow or in any intermediate position.

WARNING - Do Not Use for reciprocating air compressor service.

NOTE: 0.5 psi pressure required to open spring.

NOTE: Check valves are down-rated from 250 psi CWP to 200 psi CWP to match the Press System.

⚠ WARNING: This product can expose you to chemicals including lead, which is known to the State of California to cause cancer and birth defects or other reproductive harm. For more information go to www.P65Warnings.ca.gov.

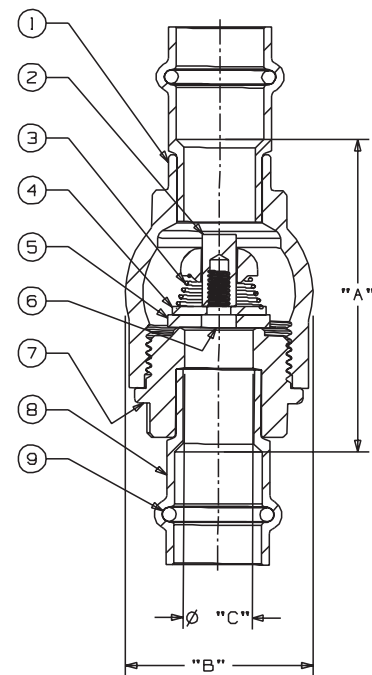

PF-480-Y (PTFE Disc)
P x P

Visit our website for the most current information.