

NIBCO® Press System Lead-Free Brass Ball & Check Valves

Features: Ball and Inline Check Valve Combined • Press Ends Leak Detection • Double Stem Seal • Two-Piece Body • PTFE Seats • Full Port • Blowout-Proof Stem

Approvals: MSS SP-110/145 • IAPMO/ANSI Z1157 • NSF/ANSI 61/372 • Conforms to ASME B16.51†

Size range: 1/2" - 1½"

Pressure rating: 250 PSI non-shock cold working pressure

Maximum pressure / temperature: 150 PSI at 250° F

Lead-free markings: White handle and blue hang tag

Applications: Drinking Water • Domestic Hot & Cold Water • HVAC (condensors, chilled water, hot water heating) • Isolation and Throttling (half-open to full-open only) • Connect to Rigid Copper Tubing Manufactured per ASTM B88, Condition H (hard drawn)

Reference Press System catalog for updated Approved Marking Tool and Jaw Compatibility Matrix list.

Not intended for steam or gas usage.



PC-FP-485-LF

Press x Press
1/2" - 1½"
(Patent Pending sizes 1-1/4" - 2")

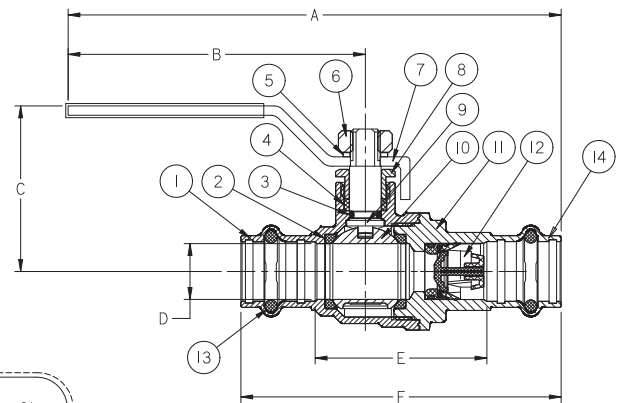

PC-FP-485-LF
Press x Press
1/2" - 1½"

MATERIAL LIST

PART	SPECIFICATION
1. Body	Forged DZR Copper Alloy - C46500
2. Seat Seal (2)	PTFE
3. O-ring	EPDM - ASTM D2000
4. Packing	PTFE
5. Washer	Stainless Steel ASTM 321
6. Lock Nut	Stainless Steel 304
7. Handle	Steel, Plated
8. Nut	Brass
9. Stem	Brass
10. Ball	Chrome Plated Brass - C46500 (1/2"-1") Stainless Steel 316 (1¼"-1½")
11. End Cap	Forged DZR Copper Alloy - C46500
12. Check Valve	OV25-HT Cartridge
13. O-ring (2)	EPDM - ASTM D2000 (Leak Detect)
14. Metal Ring (2)	Stainless Steel (1¼"-1½")

Options:

- Extended lever
- EPDM Seal for Press Ends
- Wing Handle



Handle Markings

DIMENSIONS—WEIGHTS—QUANTITIES

SIZE	A		B		C		D		E		F		Weight	
In.	In.	mm.	In.	mm.	In.	mm.	In.	mm.	In.	mm.	In.	mm.	Lbs.	Kg.
½"	5.87	149.00	3.78	96.00	1.83	46.50	0.631	16.03	1.82	46.20	3.39	86.20	0.50	0.23
¾"	6.58	167.20	3.98	101.00	2.11	53.50	0.883	22.43	2.39	60.70	4.20	106.70	0.88	0.40
1"	7.36	187.00	4.37	111.00	2.58	65.50	1.140	28.96	2.90	73.70	4.71	119.70	1.42	0.65
1¼"	8.82	224.00	5.04	128.00	2.70	68.50	1.386	35.20	3.62	91.90	5.86	148.90	2.16	0.98
1½"	10.69	271.50	6.22	158.00	3.16	80.20	1.636	41.56	4.22	107.20	7.00	177.70	3.12	1.42

IAPMO/ANSI Z1157: in addition to meeting ICG-157 test requirements, the IAPMO/ANSI Z1157 also requires Press ends to be fully tested to IAPMO PS-117 performance requirements which includes the following additional tests:

† Tested to the performance criteria of ASME B16.51
‡ Patent Pending

1. Unrestrained Hydrostatic Pressure Test at 20 °C (68°F)
2. Unrestrained Hydrostatic Pressure Test at 93 °C (200°F)
3. Static Torsion Test for Press Connections

4. Bending Test
5. Vacuum Test
6. Hydraulic Shock (Water Hammer) Test

7. Vibration Test
8. Thermal Cycling Test

9. Alternate Thermal Cycling Test
10. Dynamic Torsion Test for Press Connections



WARNING: This product can expose you to chemicals including lead, which is known to the State of California to cause cancer and birth defects or other reproductive harm. For more information go to www.P65Warnings.ca.gov.

LEAD-FREE: Weighted average lead content ≤ 0.25%